



HIGH EFFICIENCY AIR HANDLER

Features

- Industry Standard R-410A Refrigerant
- Models featuring Electric Heat without Indoor Cooling Coil
- Quiet and efficient X-13 (ECM) motor technology
- Only 35" tall and 4-way convertible for all those tight spaces
- Available from factory in upflow and horizontal configurations
- Nominal airflow up to 0.5" external static pressure with reduced airflow up to 1.0" external static pressure
- Sturdy steel construction with 1 inch [25.4 mm] of foil faced insulation for excellent sound and insulating characteristics
- Permanent, easily accessible and washable filter furnished standard
- Circuit breaker (standard on units with more than 11 kW) meets U.L. and cUL requirements for service disconnect
- Factory installed auxiliary electric heat provides exact heat for indoor comfort over a variety of applications
- Watt restrictors, standard on WBHP-17 models above 6 kW and on WBHP-21, WBHP-24 & WBHP-25 models above 11 kW, stage supplemental heat so that only the necessary amount is engaged to maintain comfort in the conditioned space
- Fan settings for selectable, customized cooling airflow over a wide variety of applications
- Cabinet leakage less than 2% at 1 inch H₂O when tested in accordance with ASHRAE standard 193

**WBHP SERIES
X-13 (ECM) Motor
Efficiencies up to 14 SEER**



TABLE OF CONTENTS

Engineering Features	3
Model Number Identification	4
Dimensional Data.....	5
Airflow Directional Data	6
Airflow Performance Data	7-9
Electrical Data	10
Electrical Wiring	11
Accessories	11
Limited Warranty	12

Engineering Features

WBHP- Series

- Quiet, efficient X-13 (ECM) motor technology providing nominal airflow to 0.5 inch [12 kPa] of external static pressure.
- Field selectable airflow to meet the requirements of particular applications.
- Low continuous fan speed.
- The most compact unit design available.
- Attractive pre-painted cabinet exterior.
- Rugged steel cabinet construction, designed for added strength and versatility.
- 1" foil faced insulation mechanically retained in blower compartment.
- Four leg rubber insulated wire motor mount.
- Circuit breakers standard on models above 11 kW and optional on models with 11 kW or less.
- Models supplied with circuit breakers meet UL and cUL requirements as a service disconnect switch.
- Provisions for field electrical connections from either side of air handler cabinet.
- Tab lock blower housing with integrated electric heaters, controls, motor and blower. Slide out design for service and maintenance convenience.
- Exclusive dependable Incoloy sheath type electric heating elements located in the blower housing provide mixed warm air.
- Field convertible for vertical upflow, vertical downflow, horizontal left hand or right hand air supply.
- Common combustible floor base accessory fits all model sizes when required for downflow installations on combustible floors.
- Durable framed cleanable air filter provided as standard in unit filter rack.
- Coil design provides low air side pressure drop, high performance and extremely compact size. All coils come with PVC condensate elbow standard.
- All indoor coils have tinned copper tubing and aluminum fins.
- Molded polymer corrosion resistant condensate drain pan is provided on all indoor coils.
- Both supply and return duct flanges provided as standard on air handler cabinet.
- Connection points for both high voltage and low voltage control wiring inside air handler cabinet.
- Concentric knockouts are provided for power connection to cabinet. Installer may pull desired hole size up to 2 inches [51 mm] for 1 1/2 inch [38 mm] conduit.
- Patented watt restrictor on heat pump models to control electric heat during heating operation.
- Internal checked TX valves are used on the indoor coil for more quiet refrigerant metering.
- Front refrigerant and drain connections.

[] Designates Metric Conversions

Watt-restrictor

Supplemental heat, provided by electric heating elements may be necessary in some areas when heating requirements for indoor comfort exceed the capacity of the heat pump system. When supplemental heat is required, units with the Watt Restrictor will restrict the amount of supplemental electric heat that can be energized dependent on the heat output of the heat pump (temperature of the air leaving the indoor heat pump coil).

The Watt-restrictor utilizes sensing devices in the unit to sense the air temperature leaving the indoor coil and disengage unnecessary heating elements when that temperature is at least 85°F [29°C]. (In this mode your system is controlled by the first stage of the wall thermostat.) This occurs only when the second stage of the wall thermostat calls for heat.

Since the heat output of the heat pump is dependent upon the outdoor air temperature, this control performs the same function as a field installed outdoor thermostat.

An additional benefit of the Watt Restrictor is that it can sense a degradation in heat pump performance due to causes other than outdoor temperature and react accordingly to bring on more supplemental electric heat.

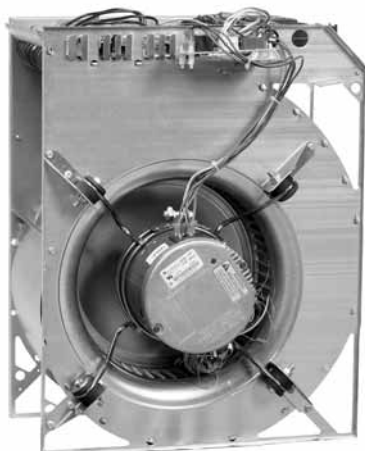
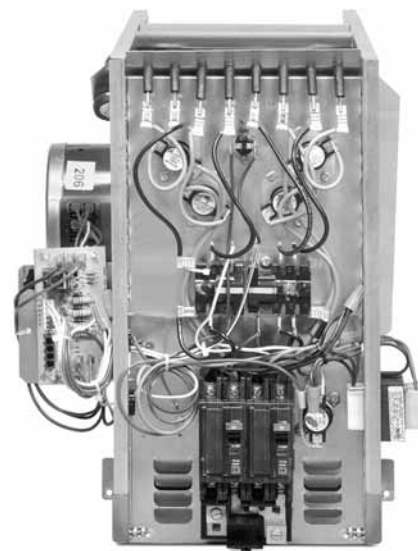

**X-13 (ECM)
MOTOR**

**BLOWER
SECTION**

Model Number Identification

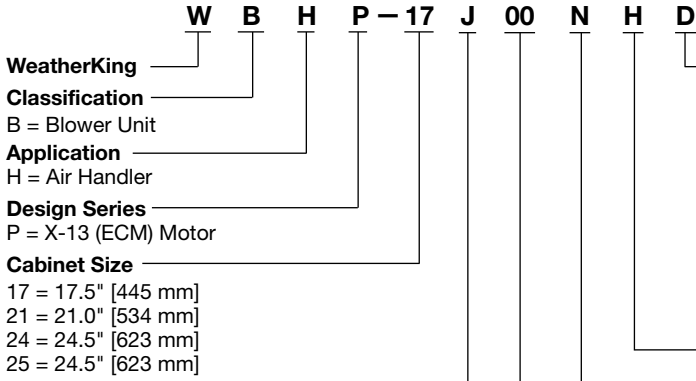

Coil Code
 A = No Coil

Coil Code	Refrigerant Type	Cabinet Width			
		17	21	24	25
1	R-410A	RCHL-24A2TH17			
2	R-410A		RCHL-36A1TH21		
4	R-410A			RCHL-48A1TH24	
7	R-410A				RCHL-60A1TH24

Airflow
 Horizontal Multi-Position

Control
 N = No Circuit Protection (Single Circuit)
 S = Circuit Breaker (Single Circuit)

Electric Heat
 00 = No Heat 14 = 14.0 kW
 06 = 4.9 kW 18 = 17.5 kW
 07 = 7.0 kW 21 = 21.0 kW
 11 = 10.0 kW

Voltage
 A = 115V-1-60
 J = 208/240V-1-60

[] Designates Metric Conversions

Available Models featuring R-410A Refrigerant
WBHP-17A00NH1
WBHP-17J06SH1
WBHP-17J07SH1
WBHP-17J11SH1
WBHP-21A00NH2
WBHP-21J06SH2
WBHP-21J07SH2
WBHP-21J11SH2
WBHP-24A00NH4
WBHP-24J06SH4
WBHP-24J07SH4
WBHP-24J11SH4
WBHP-24J18SH4
WBHP-25A00NH7
WBHP-25J11SH7
WBHP-25J18SH7

Available Models (without Coil)
WBHP-17J11SHA
WBHP-21J14SHA
WBHP-24J18SHA
WBHP-25J21SHA

Unit Dimensions

NOTE: 24" CLEARANCE REQUIRED IN FRONT OF UNIT FOR FILTER AND COIL MAINTENANCE.

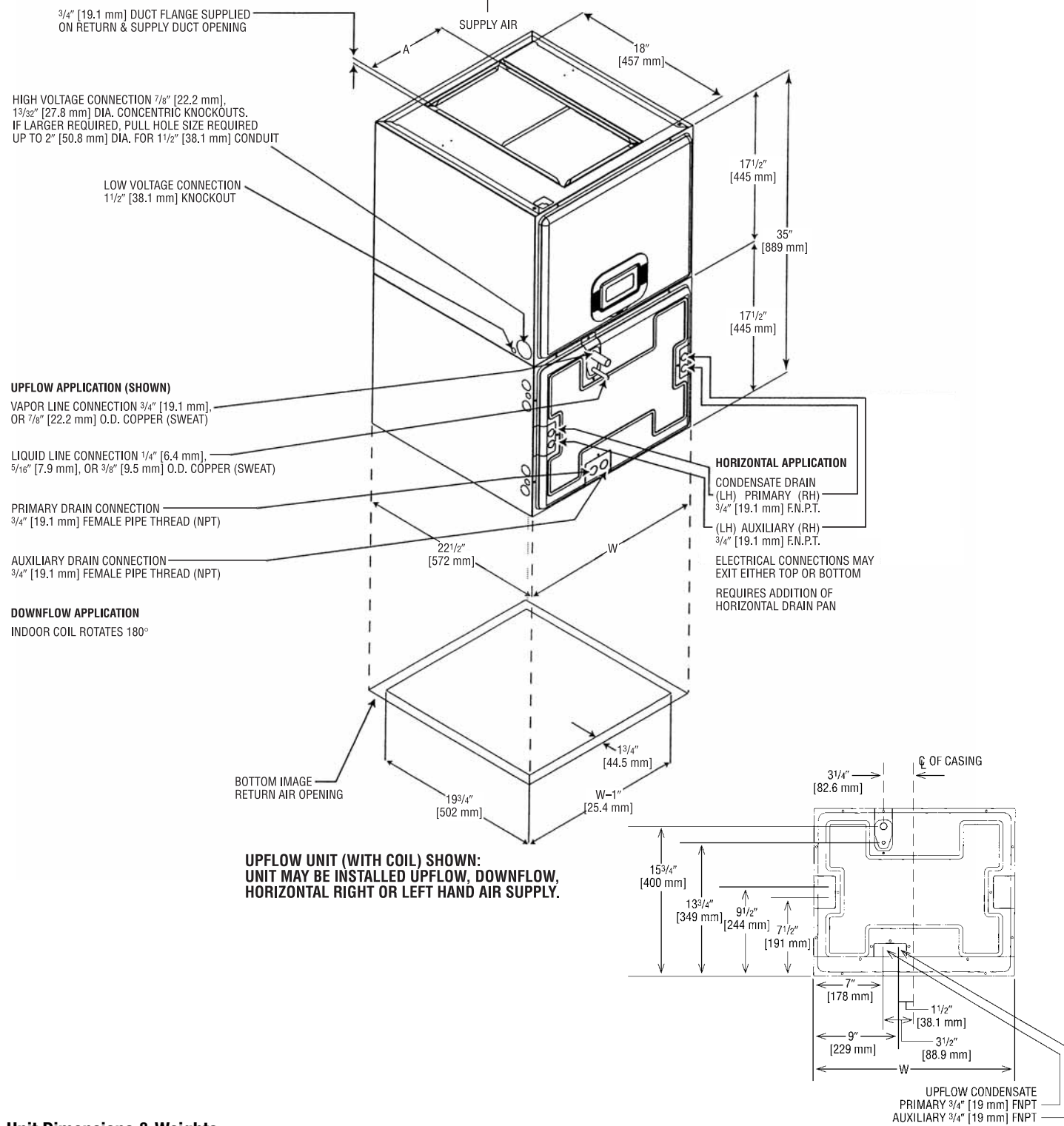

Unit Dimensions & Weights

Model Number Cabinet Size	Unit Width "W" In. [mm]	Supply Duct "A" In. [mm]	Unit Weight/Shipping Weight (Lbs.) [kg]	
			Unit With Coil (Max. kW)	Unit Without Coil (Max. kW)
17	17 1/2 [445]	79/16 [192]	92/99 [42/45]	66/75 [30/31]
21	21 [533]	97/16 [240]	109/117 [49/53]	79/87 [36/39]
24	24 1/2 [623]	113/4 [298]	125/134 [57/61]	88/97 [40/44]
25	24 1/2 [623]	113/4 [298]	125/134 [57/61]	88/97 [40/44]

Airflow Directional Data

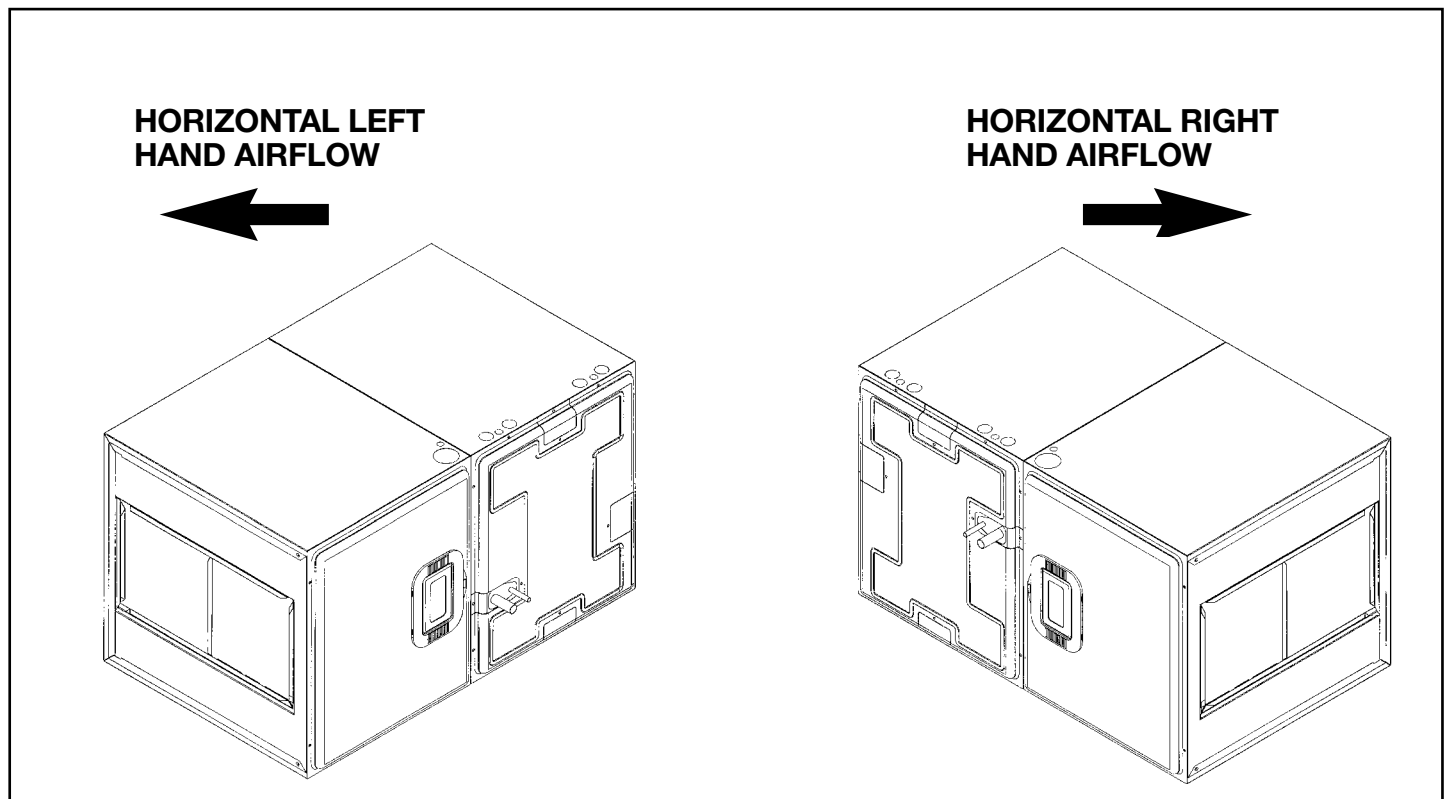
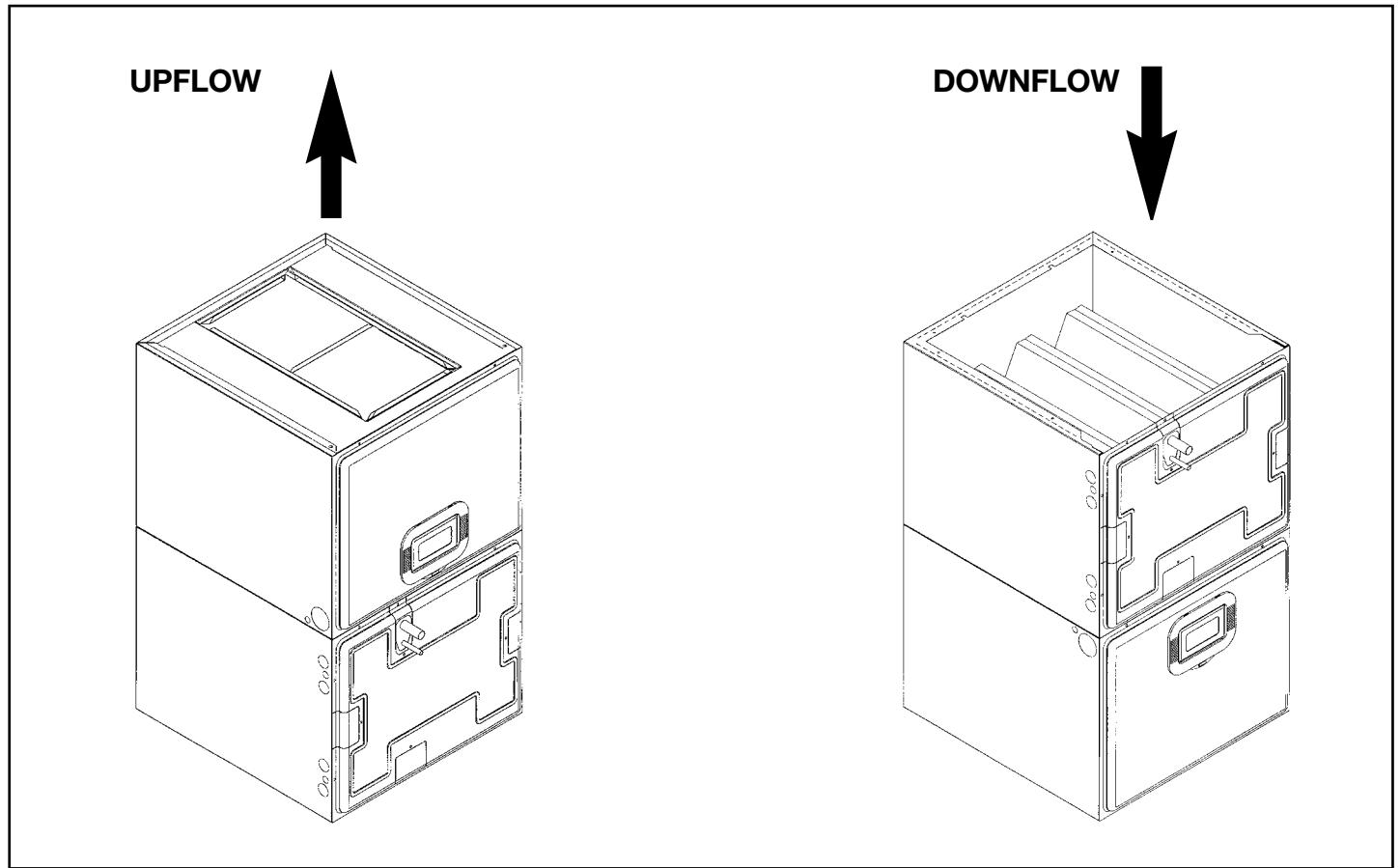

NOTE: Coil and blower section are always in a draw through configuration.

Airflow Performance

Airflow performance data is based on cooling performance with a coil and filter in place. Select performance table for appropriate unit size, voltage and number of electric heaters to be used. Make sure external static applied to unit allows operation within the minimum and maximum limits shown in table below for both cooling and electric heat operation. For optimum blower performance, operate the unit in the .2" to .5" in.

W.C. external static range. In general, the indoor motor speed tap should be as shown in table for the appropriate cooling capacity shown. Always check to make sure proper motor speed tap is connected as units are shipped from the factory connected for high speed operation (Speed Tap 5).

Airflow Operating Limits

Model Cabinet Size	17		21		24		25	
Cooling BTUH Cooling Tons Nominal	18,000 1.5	24,000 2	30,000 2.5	36,000 3	42,000 3.5	48,000 4	60,000 5	60,000 5
Heat Pump or Air Conditioning Maximum Heat/Cool CFM [L/s] (37.5 CFM [18 L/s]/1,000 BTUH) (450 CFM [212 L/s]/Ton Nominal)	675 [319]	900 [425]	1125 [531]	1350 [637]	1575 [743]	1800 [850]	2025 [956]	2250 [1062]
Heat Pump or Air Conditioning Nominal Heat/Cool CFM [L/s] (33.3 CFM [16 L/s]/1,000 BTUH) (400 CFM [189 L/s]/Ton Nominal)	600 [283]	800 [378]	1000 [472]	1200 [566]	1400 [661]	1600 [755]	1800 [850]	2000 [944]
Heat Pump or Air Conditioning Minimum Heat/Cool CFM [L/s] (30.0 CFM [14 L/s]/1,255 BTUH) (360 CFM [170 L/s]/Ton Nominal)	540 [255]	720 [330]	900 [425]	1080 [510]	1260 [595]	1440 [680]	1620 [765]	1800 [850]
Maximum KW Electric Heating & Minimum Electric Heat CFM [L/s]	11 560 [264]	11 560 [264]	14 900 [425]	14 900 [425]	18 1220 [576]	18 1220 [576]	21 1460 [689]	21 1460 [689]
Maximum Electric Heat Rise °F [°C]	85 [29]	85 [29]	70 [21]	70 [21]	65 [18]	65 [18]	65 [18]	65 [18]

NOTE: See Airflow Performance Data for Recommended Blower Motor Speed.

[] Designates Metric Conversions

Airflow Performance Data

Model Cabinet Size	Tonnage	Electric Heaters	Blower Motor		CFM [L/s] (Watts)/External Static Pressure—Inches W.C. [kPa] with filter and Indoor Coil										
			Nominal Speed Tap	Volts	.10 [.02]	.20 [.05]	.30 [.07]	.40 [.10]	.50 [.12]	.60 [.15]	.70 [.17]	.80 [.20]	.90 [.23]	1.0 [.25]	
-17	1.5 Ton Air Flow	none	2	208/240	659 [311] (74)	625 [294] (80)	581 [274] (84)	539 [254] (88)	—	—	—	—	—	—	
		none	3	208/240	790 [372] (98)	759 [358] (105)	722 [340] (113)	687 [324] (119)	650 [306] (126)	615 [290] (131)	573 [270] (139)	552 [260] (145)	507 [239] (150)	460 [217] (155)	
		3 (max.)	2	208/240	649 [306] (79)	615 [290] (84)	571 [269] (88)	529 [249] (92)	—	—	—	—	—	—	—
		3 (max.)	3	208/240	773 [365] (110)	736 [347] (113)	699 [330] (118)	677 [320] (126)	640 [302] (132)	605 [286] (141)	563 [266] (146)	542 [256] (154)	497 [235] (157)	450 [212] (162)	—
		none	2	115	651 [307] (76)	627 [295] (82)	583 [275] (86)	541 [255] (90)	—	—	—	—	—	—	—
		none	3	115	776 [366] (105)	743 [351] (109)	724 [342] (118)	687 [324] (122)	658 [311] (131)	617 [291] (136)	595 [281] (144)	555 [262] (148)	517 [244] (152)	460 [217] (162)	—
	2.0 Ton Air Flow	none	4	208/240	844 [398] (141)	819 [386] (146)	799 [377] (155)	764 [360] (160)	—	—	—	—	—	—	—
		none	5	208/240	958 [452] (162)	934 [440] (172)	914 [431] (176)	888 [419] (186)	855 [403] (189)	816 [380] (210)	785 [370] (204)	760 [358] (214)	708 [334] (223)	672 [317] (226)	—
		3 (max.)	4	208/240	834 [393] (146)	809 [831] (150)	789 [372] (159)	754 [355] (164)	—	—	—	—	—	—	—
		3 (max.)	5	208/240	946 [446] (179)	922 [435] (189)	902 [426] (193)	876 [413] (203)	843 [398] (206)	804 [380] (216)	773 [365] (221)	748 [353] (231)	696 [328] (240)	660 [311] (243)	—
		none	4	115	846 [399] (143)	821 [387] (148)	801 [378] (157)	766 [361] (162)	—	—	—	—	—	—	—
		none	5	115	964 [455] (167)	945 [446] (178)	914 [431] (181)	888 [419] (191)	861 [406] (196)	821 [387] (205)	787 [372] (210)	761 [359] (218)	726 [342] (220)	690 [326] (230)	—
-21	2.5 Ton Air Flow	none	2	208/240	1068 [504] (138)	1041 [491] (147)	1001 [472] (153)	972 [458] (161)	—	—	—	—	—	—	
		none	3	208/240	1187 [560] (180)	1162 [548] (188)	1125 [530] (192)	1099 [518] (200)	1058 [499] (208)	1013 [478] (215)	982 [463] (223)	951 [448] (232)	899 [424] (234)	855 [403] (237)	
		4 (max.)	2	208/240	1035 [488] (143)	1007 [475] (152)	966 [455] (158)	936 [441] (169)	—	—	—	—	—	—	
		4 (max.)	3	208/240	1157 [546] (182)	1132 [534] (192)	1095 [517] (198)	1069 [505] (209)	1028 [485] (218)	983 [464] (228)	952 [449] (239)	921 [435] (250)	869 [410] (255)	825 [389] (262)	—
		none	2	115	1070 [504] (138)	1043 [492] (147)	1004 [473] (153)	974 [459] (161)	—	—	—	—	—	—	—
		none	3	115	1138 [537] (175)	1113 [525] (186)	1075 [507] (191)	1053 [497] (203)	1004 [474] (210)	957 [451] (216)	932 [440] (226)	901 [425] (231)	855 [404] (242)	800 [378] (252)	—
	3.0 Ton Air Flow	none	4	208/240	1269 [598] (207)	1236 [583] (219)	1174 [554] (226)	1149 [542] (236)	—	—	—	—	—	—	—
		none	5	208/240	1397 [659] (287)	1377 [649] (307)	1346 [635] (317)	1318 [622] (320)	1291 [609] (322)	1264 [596] (319)	1234 [582] (312)	1190 [561] (326)	1155 [545] (351)	1126 [531] (368)	—
		4 (max.)	4	208/240	1241 [585] (222)	1208 [570] (234)	1174 [554] (241)	1149 [542] (251)	—	—	—	—	—	—	—
		4 (max.)	5	208/240	1366 [645] (302)	1346 [635] (313)	1315 [621] (323)	1287 [608] (331)	1260 [595] (341)	1233 [582] (346)	1203 [568] (358)	1159 [547] (371)	1124 [530] (381)	1095 [517] (387)	—
		none	4	115	1269 [598] (207)	1236 [583] (219)	1174 [554] (226)	1149 [542] (236)	—	—	—	—	—	—	—
		none	5	115	1370 [646] (292)	1343 [634] (302)	1309 [618] (309)	1285 [607] (319)	1258 [594] (330)	1221 [576] (336)	1182 [558] (348)	1147 [542] (357)	1117 [527] (366)	1080 [510] (375)	—

NOTES:

X-13 (ECM) NOTES (X-13 (ECM) Motor Speed Changes)

X-13 (ECM) Motors require no voltage change between 208 and 240 volts.

If application exceeds 0.5" of static, adjust the motor speed to the high static speed as described below:

All X-13 (ECM) motors have 5 speed tabs. Speed tab 1 is for continuous fan. Speed 2 (Low Static) and speed tab 3 (High Static) are lower tonnage. Speed tab 4 (Low Static) and Speed tab 5 (High Static) are for higher tonnage.

The lower static speed 2 (lower tonnage) and speed tab 4 (Higher tonnage) are used for external static below 0.5".

For external static exceeding 0.5", move the blue wire from the X-13 (ECM) motor to appropriate high static speed tab 3 (Lower tonnage) or speed tab 5 (Higher tonnage)

[] Designates Metric Conversions

Airflow Performance Data (con't.)

Model Cabinet Size	Tonnage	Electric Heaters	Blower Motor		CFM [L/s] (Watts)/External Static Pressure—Inches W.C. [kPa] with filter and Indoor Coil									
			Nominal Speed Tap	Volts	.10 [.02]	.20 [.05]	.30 [.07]	.40 [.10]	.50 [.12]	.60 [.15]	.70 [.17]	.80 [.20]	.90 [.23]	1.0 [.25]
-24	3.5 Ton Air Flow	none	2	208/240	1438 [678] (205)	1409 [664] (217)	1375 [648] (229)	1341 [632] (252)	—	—	—	—	—	—
		none	3	208/240	1568 [740] (279)	1538 [725] (290)	1507 [711] (303)	1471 [694] (313)	1435 [677] (333)	1403 [662] (338)	1362 [642] (358)	1318 [622] (365)	1287 [607] (374)	1250 [589] (405)
		5 (max.)	2	208/240	1414 [667] (230)	1384 [653] (242)	1350 [637] (254)	1315 [620] (277)	—	—	—	—	—	—
		5 (max.)	3	208/240	1548 [730] (304)	1518 [716] (316)	1487 [701] (328)	1451 [684] (338)	1415 [667] (358)	1383 [653] (368)	1342 [633] (388)	1298 [612] (395)	1267 [597] (409)	1230 [580] (455)
		none	2	115	1448 [683] (205)	1419 [669] (217)	1385 [653] (229)	1351 [637] (252)	—	—	—	—	—	—
		none	3	115	1559 [735] (294)	1527 [720] (308)	1497 [706] (322)	1466 [691] (335)	1431 [675] (349)	1378 [650] (367)	1349 [636] (379)	1306 [606] (393)	1271 [599] (406)	1250 [589] (417)
	4.0 Ton Air Flow	none	4	208/240	1640 [773] (311)	1604 [757] (326)	1587 [748] (335)	1559 [735] (376)	—	—	—	—	—	—
		none	5	208/240	1789 [844] (413)	1762 [831] (427)	1731 [816] (433)	1699 [801] (449)	1667 [786] (462)	1635 [771] (482)	1602 [756] (498)	1546 [729] (516)	1515 [715] (529)	1465 [691] (542)
		5 (max.)	4	208/240	1613 [761] (331)	1574 [742] (346)	1557 [734] (355)	1529 [721] (396)	—	—	—	—	—	—
		5 (max.)	5	208/240	1759 [830] (433)	1732 [817] (447)	1701 [802] (453)	1669 [787] (469)	1637 [772] (482)	1605 [757] (502)	1572 [741] (518)	1516 [715] (536)	1485 [700] (549)	1435 [677] (562)
		none	4	115	1642 [774] (311)	1606 [757] (326)	1589 [749] (335)	1561 [736] (376)	—	—	—	—	—	—
		none	5	115	1811 [854] (423)	1791 [845] (436)	1760 [830] (451)	1730 [816] (464)	1700 [802] (479)	1669 [787] (492)	1606 [757] (516)	1573 [742] (529)	1538 [725] (542)	1462 [689] (555)
-25	5.0 Ton Air Flow	none	2	208/240	1872 [883] (373)	1837 [866] (393)	1798 [848] (407)	1763 [832] (419)	—	—	—	—	—	—
		none	3	208/240	2075 [979] (497)	2036 [960] (511)	2017 [951] (533)	1984 [936] (553)	1944 [917] (563)	1910 [901] (582)	1889 [891] (599)	1846 [871] (617)	1805 [851] (626)	1783 [841] (638)
		5 (max.)	2	208/240	1831 [854] (393)	1795 [847] (413)	1756 [828] (427)	1720 [811] (439)	—	—	—	—	—	—
		5 (max.)	3	208/240	2043 [964] (517)	2004 [945] (531)	1985 [936] (553)	1951 [920] (573)	1912 [901] (583)	1878 [886] (602)	1857 [876] (619)	1814 [856] (637)	1773 [836] (646)	1751 [826] (658)
		none	2	115	1872 [883] (373)	1837 [866] (393)	1798 [848] (407)	1763 [832] (419)	—	—	—	—	—	—
		none	3	115	2075 [979] (497)	2036 [960] (511)	2017 [951] (533)	1984 [936] (553)	1944 [917] (563)	1910 [901] (582)	1889 [891] (599)	1846 [871] (617)	1805 [851] (626)	1783 [841] (638)
		none	4 or 5	208/240	2102 [992] (550)	2072 [977] (568)	2042 [963] (584)	2011 [949] (593)	1974 [931] (610)	1949 [919] (631)	1916 [904] (644)	1884 [889] (662)	1851 [873] (669)	1810 [854] (692)
		5 (max.)	4 or 5	208/240	2070 [976] (560)	2040 [962] (578)	2010 [948] (594)	1979 [933] (613)	1942 [916] (620)	1917 [904] (641)	1884 [889] (654)	1852 [874] (672)	1819 [858] (679)	1778 [839] (702)
		none	4 or 5	115	2102 [992] (550)	2072 [977] (568)	2042 [963] (584)	2011 [949] (593)	1974 [931] (610)	1949 [919] (631)	1916 [904] (644)	1884 [889] (662)	1851 [873] (669)	1810 [854] (692)

NOTES:

X-13 (ECM) NOTES (X-13 (ECM) Motor Speed Changes)

X-13 (ECM) Motors require no voltage change between 208 and 240 volts.

If application exceeds 0.5" of static, adjust the motor speed to the high static speed as described below:

All X-13 (ECM) motors have 5 speed tabs. Speed tab 1 is for continuous fan. Speed 2 (Low Static) and speed tab 3 (High Static) are lower tonnage. Speed tab 4 (Low Static) and Speed tab 5 (High Static) are for higher tonnage.

The lower static speed 2 (lower tonnage) and speed tab 4 (Higher tonnage) are used for external static below 0.5".

For external static exceeding 0.5", move the blue wire from the X-13 (ECM) motor to appropriate high static speed tab 3 (Lower tonnage) or speed tab 5 (Higher tonnage)

[] Designates Metric Conversions

Blower Motor Electrical Data: A Voltage (115V)

Model Size/Elec. Designation	Voltage	Phase	Hertz	HP [W]	RPM	Speeds	Circuit Amps.	Minimum Circuit Ampacity	Maximum Circuit Protector
WBHP-17A00NH*	115	1	60	1/3 [249]	300-1100	5	3.3	5.0	15
WBHP-21A00NH*	115	1	60	1/2 [373]	300-1100	5	5.0	7.0	15
WBHP-24A00NH*	115	1	60	3/4 [559]	300-1100	5	5.8	8.0	15
WBHP-25A00NH*	115	1	60	3/4 [559]	300-1100	5	7.7	10.0	15

Blower Motor Electrical Data: J Voltage (208/240V)

Model Size/Elec. Designation	Voltage	Phase	Hertz	HP [W]	RPM	Speeds	Circuit Amps.	Minimum Circuit Ampacity	Maximum Circuit Protector
WBHP-17A00NH*	115	1	60	1/3 [249]	300-1100	5	3.3	5.0	15
WBHP-21A00NH*	115	1	60	1/2 [373]	300-1100	5	5.0	7.0	15
WBHP-24A00NH*	115	1	60	3/4 [559]	300-1100	5	5.8	8.0	15
WBHP-25A00NH*	115	1	60	3/4 [559]	300-1100	5	7.7	10.0	15

Electric Heat Electrical Data

Model Elec./KW Designation	Heater KW Volts 208/240	PH/HZ	Heater No./KW & 240V	Type Supply Circuit Single Circuit Multiple Circuit	Circuit Amps.	Minimum Circuit Ampacity	Maximum Circuit Protector
WBHP-17J06SH*	3.7/4.9	1/60	2/2.5	Single Circuit	19.8/22.4	25/29	25/30
WBHP-17J07SH*	5.3/7.0	1/60	2/3.5	Single Circuit	27.5/31.2	35/39	40/40
WBHP-17J11SH*	7.5/10.0	1/60	3/3.3	Single Circuit	38.1/43.7	48/55	50/60
WBHP-21J06SH*	3.7/4.9	1/60	2/2.5	Single Circuit	20.9/23.5	27/30	30/30
WBHP-21J07SH*	5.3/7.0	1/60	2/3.5	Single Circuit	28.6/32.3	36/41	40/45
WBHP-21J11SH*	7.5/10.0	1/60	3/3.3	Single Circuit	39.2/44.8	49/56	50/60
WBHP-21J14SH*	10.5/14.0	1/60	4/3.5	Single Circuit	54.1/61.4	68/77	70/80
	5.3/7.0		2/3.5	Multiple Ckt. 1	28.6/32.3	36/41	40/45
	5.3/7.0		2/3.5	Multiple Ckt. 2	25.5/29.2	32/37	35/40
WBHP-24J06SH*	3.7/4.9	1/60	2/2.5	Single Circuit	22.0/24.6	28/31	30/35
WBHP-24J07SH*	5.3/7.0	1/60	2/3.5	Single Circuit	29.7/33.4	38/42	40/45
WBHP-24J11SH*	7.5/10.0	1/60	3/3.3	Single Circuit	40.3/45.9	51/58	60/60
WBHP-24J18SH*	13.2/17.5	1/60	5/3.5	Single Circuit	67.7/77.1	85/97	90/100
	5.3/7.0		2/3.5	Multiple Ckt. 1	29.7/33.4	38/42	40/45
	7.9/10.5		3/3.5	Multiple Ckt. 2	38.0/43.8	48/55	50/60
WBHP-25J11SH*	7.5/10.0	1/60	3/3.3	Single Circuit	41.8/47.4	53/60	60/60
WBHP-25J18SH*	13.2/17.5	1/60	5/3.5	Single Circuit	69.2/78.6	87/99	90/100
	5.3/7.0		2/3.5	Multiple Ckt. 1	31.2/34.9	39/44	40/45
	7.9/10.5		3/3.5	Multiple Ckt. 2	38.0/43.8	48/55	50/60
WBHP-25J21SH*	15.0/20.0	1/60	6/3.3	Single Circuit	77.8/89.0	98/112	100/125
	7.5/10.0		3/3.3	Multiple Ckt. 1	41.8/47.4	53/60	60/70
	7.5/10.0		3/3.3	Multiple Ckt. 2	36.1/41.7	46/53	50/60

Supply circuit protective devices may be fuses or "HACR" type circuit breakers. Largest motor load is included in single circuit and circuit 1 multiple circuit. If non-standard fuse size is specified, use next size larger standard fuse size.

[] Designates Metric Conversions

Electrical Wiring

Power Wiring

- Field wiring must comply with the National Electrical Code (C.E.C. in Canada) and any applicable local ordinance.
- Supply wiring must be 75°C minimum copper conductors only.
- See electrical data for product Ampacity rating and Circuit Protector requirement.

Grounding

- This product must be sufficiently grounded in accordance with National Electrical Code (C.E.C. in Canada) and any applicable local ordinance.
- A grounding lug is provided.

Combustible Floor Base for Downflow Installations

Model Cabinet Size	Combustible Floor Base Model Number	Opening Front of Unit "W" Width-Inches [mm]	Opening Side of Unit "D" Depth-Inches [mm]
All Models	RXBB-AA	14 ³ / ₈ " [365]	20 ⁵ / ₈ " [524]

ACCESSORIES—KITS—PARTS

- **Combustible Floor Base RXBB-AA** for downflow applications.
- **Jumper Bar Kit 3 Ckt. to 1 Ckt. RXBJ-A31** is used to convert single phase multiple three circuit units to a single supply circuit. Kit includes cover and screw for line side terminals.
- **Jumper Bar Kit 2 Ckt. to 1 Ckt. RXBJ-A21** is used to convert single phase multiple two circuit units to a single supply circuit. Kit includes cover and screw for line side terminals.

Note: No jumper bar kit is available to convert three phase multiple two circuit units to a single supply circuit.

- **Finger Safe Circuit Breaker Cover**—Part Number 45-23203-01. One is required for each circuit breaker pole, if jumper bar is removed to provide multiple supply circuits.
- **Evaporator Horizontal Drain Pan Model RXBD-CB:** all unit sizes.
- **External Auxiliary Horizontal Drain Pan. RXBM-AA06**—Fits all models.
- **Replacement Filters**

Model Cabinet Size	Filter Size In. [mm]	Part Number
17	16.25 x 21 [413 x 533]	54-23217-02
21	19.75 x 21 [502 x 533]	54-23217-03
24	23.25 x 21 [591 x 533]	54-23217-04
25	23.25 x 21 [591 x 533]	54-23217-04

[] Designates Metric Conversions

GENERAL TERMS OF LIMITED WARRANTY*

WeatherKing will furnish a replacement for any part of this product which fails in normal use and service within the applicable periods stated, in accordance with the terms of the limited warranty.

Parts.....Five (5) Years

***For complete details of the Limited and Conditional Warranties, including applicable terms and conditions, contact your local contractor or the Manufacturer for a copy of the product warranty certificate.**

Before proceeding with installation, refer to installation instructions packaged with each model, as well as complying with all Federal, State, Provincial, and Local codes, regulations, and practices.



"In keeping with its policy of continuous progress and product improvement, WeatherKing reserves the right to make changes without notice."