

FPQ / 3310
 FAN FORCED
 WALL HEATER

- Heavy 18 gauge steel construction
- Powder coated paint finish
- Steel block fin element
- All units equipped with automatic over-heat limit protection
- Vane Axial fan blade produces 175 CFM
- Dual wattage and voltage units available for 208/240 volts
- Surface Mounting Frame (shown) available for non-recessed applications
- Units can be built with factory installed Thermostats, Summer Fan Switch, and Disconnects (See Catalog)

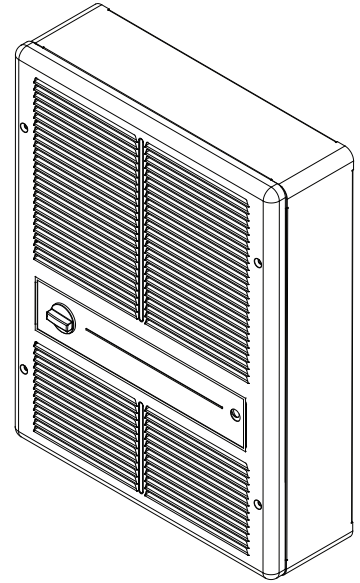

• Made in the U.S.A.

SUBMITTAL DATA SHEET

CUSTOMER				DATE	
PROJECT					
TAG					
QUANTITY					
MODEL					
KILOWATTS					
VOLTS					
PHASE	SINGLE	SINGLE	SINGLE	SINGLE	
DISCONNECT					
THERMOSTAT					
FAN SWITCH					

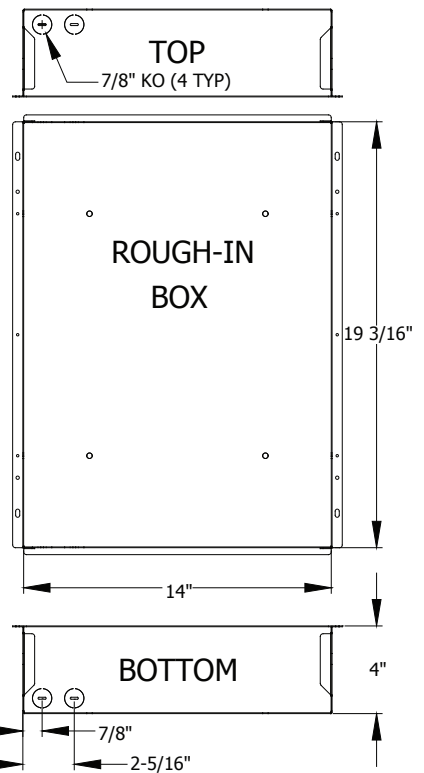
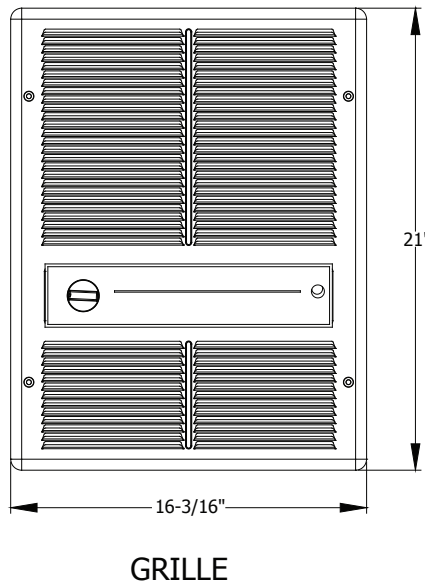
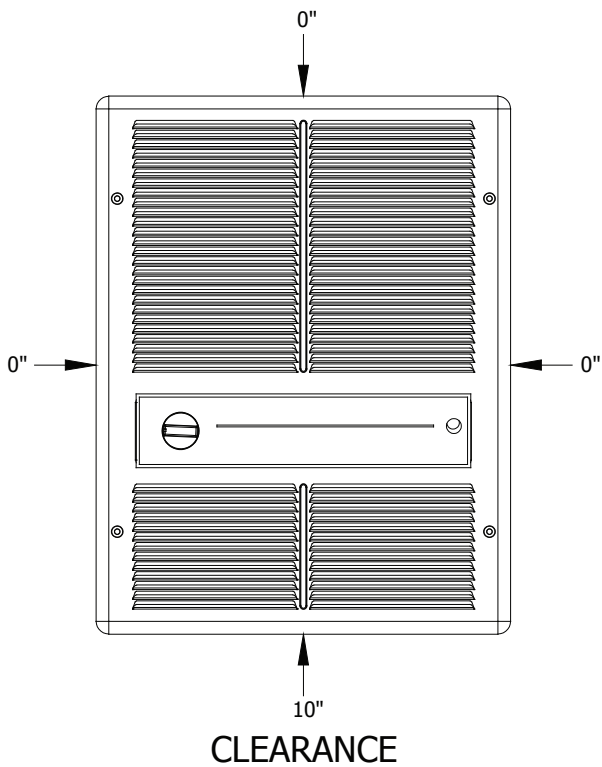

Rough in dimensions
 14-1/8"W x 19-1/2"H