



HIGH EFFICIENCY 15 and 17 SEER TWO-STAGE HEAT PUMP ENVIRONMENTALLY SOUND R-410A REFRIGERANT

2, 3, 4, and 5 TONS SPLIT SYSTEM

208 / 230 Volt, 1-phase, 60 Hz

REFRIGERATION CIRCUIT

- Copeland Scroll UltraTech™ compressors on all models
- Crankcase Heater factory installed
- Suction line accumulator factory installed
- Bi-flow filter-drier included for field installation
- Integrated solid state control with Time-Temperature Defrost
- High, Low, and Compressor Unloader pressure switches
- Discharge gas thermostat
- Copper tube / aluminum fin coil

PERFORMANCE

- 2-speed Fan Motors factory wired on all models
- High performance compressor sound shield standard

EASY TO INSTALL AND SERVICE

- Comfort Alert™ UltraTech™ Diagnostics device on all models
- Easy Access service valves on all models
- Innovative control box design
- External high and low refrigerant service ports
- Fan motor in-line disconnect plug
- Only two screws to access control panel
- Factory charged with R-410A refrigerant

BUILT TO LAST

- High gloss, baked-on powder coat finish over galvanized steel
- Post-painted (black) coil fins
- Coated, weather-resistant cabinet screws
- Coated inlet grille with 3/8" (10mm) spacing for extra protection
- Corner Posts for extra strength and style
- 10 year No-Hassle replacement limited warranty
- 10 year compressor limited warranty
- 10 year coil limited warranty
- 7 year parts limited warranty



This product has been designed and manufactured to meet ENERGY STAR criteria for energy efficiency when matched with appropriate coil components. However, proper refrigerant charge and proper air flow are critical to achieve rated capacity and efficiency. Installation of this product should follow the manufacturer's refrigerant charging and air flow instructions. Failure to confirm proper charge and airflow may reduce energy efficiency and shorten equipment life.



Rated in accordance with ARI Standard 210/240. Certification applies only when used with proper components as listed with ARI.



Model Number	Size (tons)	Nominal Btu/hr	Min. Circuit Ampacity	Max. Fuse or Breaker	Operating Dimensions height x width x depth in. (mm)	Ship / Operating Weight lbs. (kg)
T4H524GKD	2	24,000	13.5	20	36 7/8 x 35 x 35 (937 x 889 x 889)	309 / 266 (140 / 121)
T4H736GKD	3	36,000	22.1	35	40 1/4 x 35 x 35 (1023 x 889 x 889)	326 / 279 (148 / 127)
T4H548GKD	4	48,000	31.5	50	40 1/4 x 35 x 35 (1023 x 889 x 889)	329 / 286 (149 / 130)
T4H560GKD	5	60,000	35.6	60	40 1/4 x 35 x 35 (1023 x 889 x 889)	350 / 308 (159 / 140)

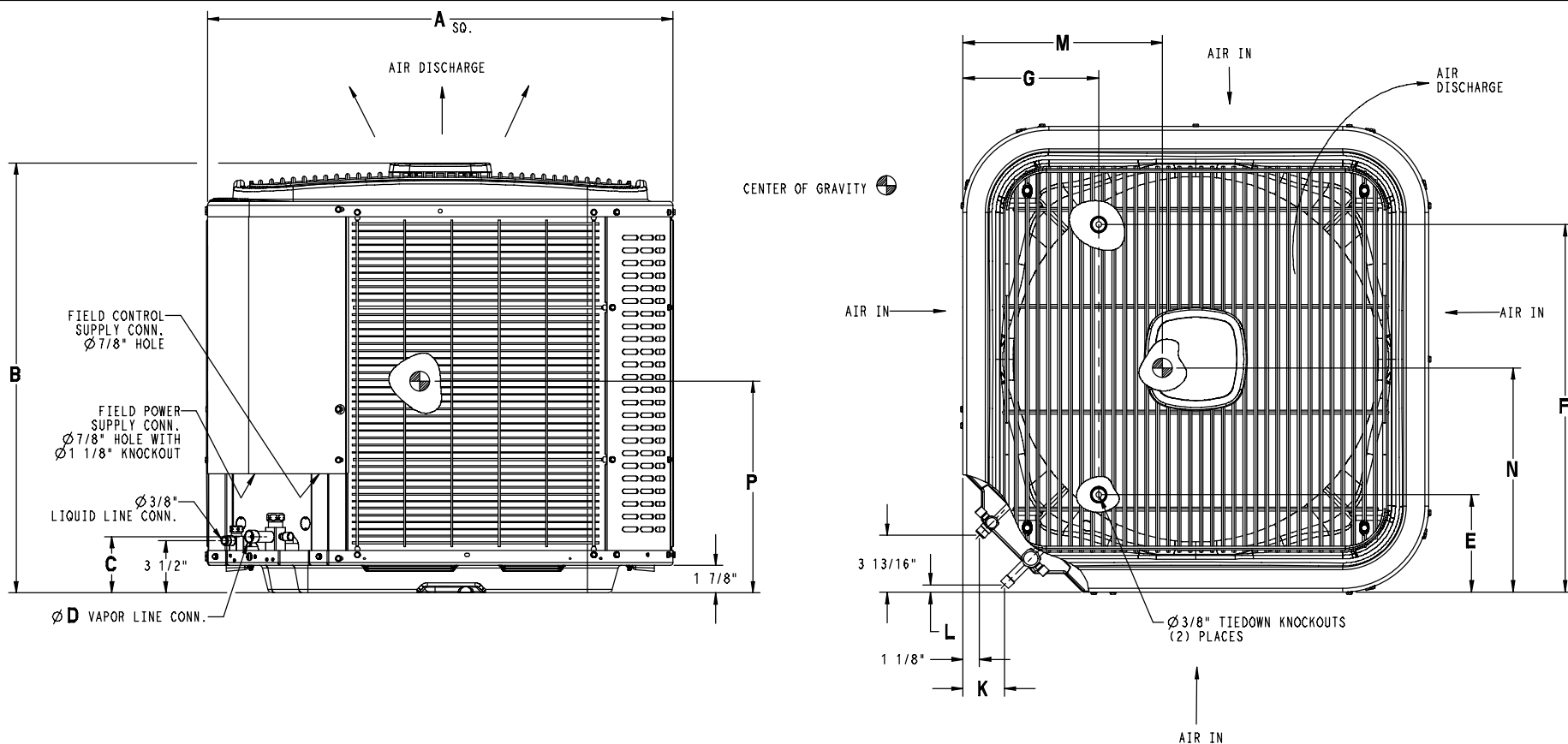

Model	Dimensions Inches												Minimum Mounting Pad Size	Crated Dimensions B(h) x A(w) x R(d)
	A	B	C	D	E	F	G	K	L	M	N	P		
T4H524GKD	35	36 ⁷ / ₈	3 ³ / ₄	5 ⁸ / ₁₆	6 ⁹ / ₁₆	28 ⁷ / ₁₆	9 ¹ / ₈	2 ¹³ / ₁₆	1/2	15	16	16	35 x 35	42 ³ / ₄ x 39 ¹ / ₄ x 36 ¹ / ₈
T4H736GKD	35	40 ¹ / ₄	3 ³ / ₄	3 ⁴ / ₈	6 ⁹ / ₁₆	28 ⁷ / ₁₆	9 ¹ / ₈	2 ¹³ / ₁₆	1/2	17	17	18	35 x 35	46 ¹ / ₈ x 39 ¹ / ₄ x 36 ¹ / ₈
T4H548GKD	35	40 ¹ / ₄	3 ⁷ / ₈	7 ⁸ / ₁₆	6 ⁹ / ₁₆	28 ⁷ / ₁₆	9 ¹ / ₈	2 ¹⁵ / ₁₆	5 ⁸ / ₁₆	17	17	18	35 x 35	46 ¹ / ₈ x 39 ¹ / ₄ x 36 ¹ / ₈
T4H560GKD	35	40 ¹ / ₄	3 ⁷ / ₈	7 ⁸ / ₁₆	6 ⁹ / ₁₆	28 ⁷ / ₁₆	9 ¹ / ₈	2 ¹⁵ / ₁₆	5 ⁸ / ₁₆	17	15	18	35 x 35	46 ¹ / ₈ x 39 ¹ / ₄ x 36 ¹ / ₈

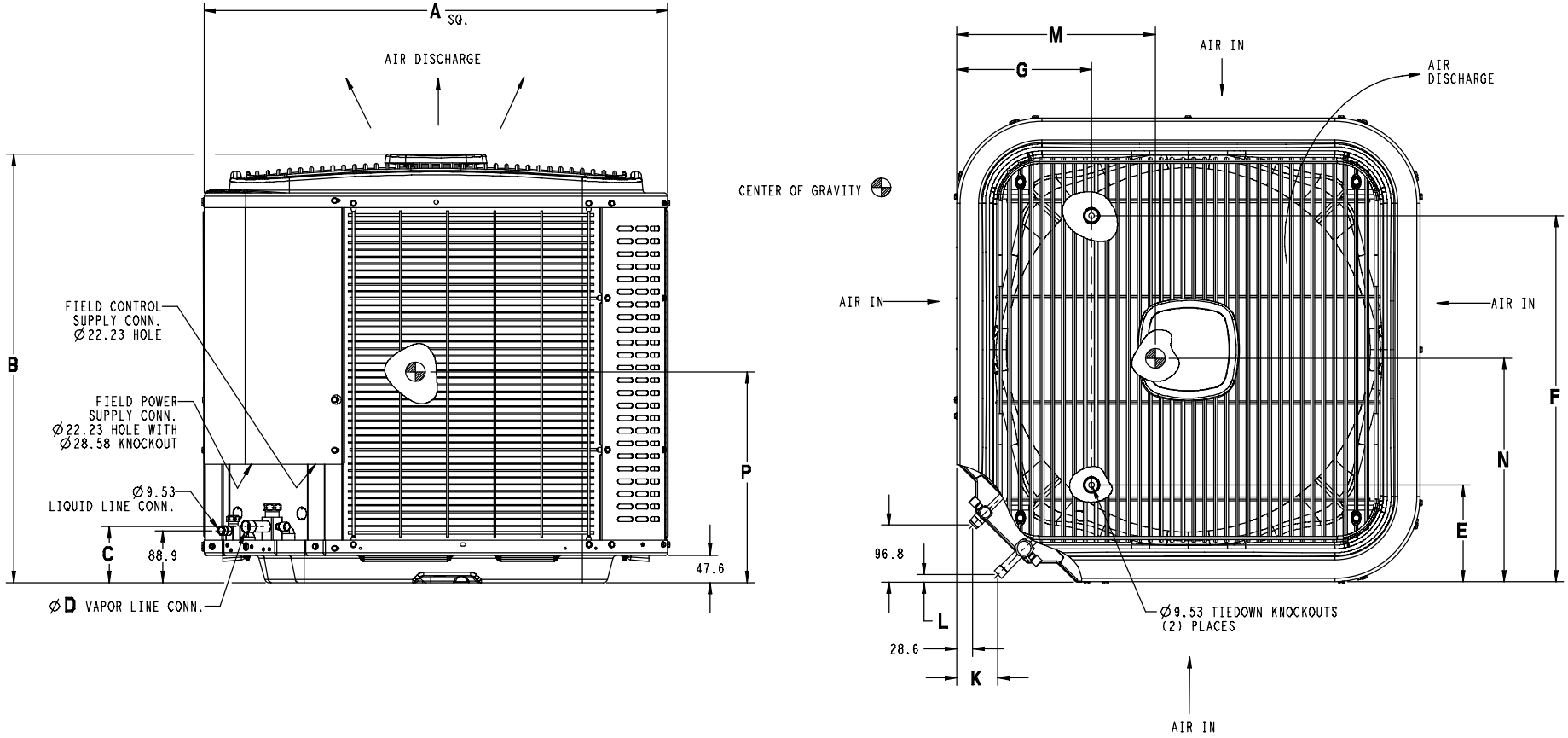

Model	Dimensions MM												Minimum Mounting Pad Size	Crated Dimensions B(h) x A(w) x R(d)
	A	B	C	D	E	F	G	K	L	M	N	P		
T4H524GKD	889	937	95	16	167	722	232	71	13	381	406	406	889 x 889	1086 x 998 x 918
T4H736GKD	889	1023	95	19	167	722	232	71	13	432	432	457	889 x 889	1172 x 998 x 918
T4H548GKD	889	1023	98	22	167	722	232	75	16	432	432	457	889 x 889	1172 x 998 x 918
T4H560GKD	889	1023	98	22	167	722	232	75	16	432	381	457	889 x 889	1172 x 998 x 918

PHYSICAL DATA

Model Size	24	36	48	60	
Nominal Cooling Capacity (BTU/hr)	24,000	36,000	48,000	60,000	
Nominal SEER	15.0	17.0	15.0	15.0	
Sound Rating, High Speed Fan (dBA)	72	72	71	73	
Low Speed Fan (dBA)	70	72	70	73	
PSC Fan Motor HP	1/10	1/10	1/4	1/4	
Fan RPM High	825	825	825	825	
Fan RPM Low	750	750	750	750	
Fan CFM (High)	2595	2595	3670	3670	
Coil Face Area (ft ²)	22.69	25.21	25.21	25.21	
Coil Rows – fins per inch	2–20	2–20	2–20	2–20	
Low Pressure Switch	Open Pressure Close Pressure	23 ± 5 PSIG 55 ± 5 PSIG	23 ± 5 PSIG 55 ± 5 PSIG	23 ± 5 PSIG 55 ± 5 PSIG	23 ± 5 PSIG 55 ± 5 PSIG
Hi Pressure Switch	Open Pressure Close Pressure	670 ± 10 PSIG 470 ± 25 PSIG	670 ± 10 PSIG 470 ± 25 PSIG	670 ± 10 PSIG 470 ± 25 PSIG	670 ± 10 PSIG 470 ± 25 PSIG
*Compressor Unloader Pressure Switch	Open Pressure Close Pressure	525 ± 15 PSIG 420 ± 15 PSIG	525 ± 15 PSIG 420 ± 15 PSIG	525 ± 15 PSIG 420 ± 15 PSIG	525 ± 15 PSIG 420 ± 15 PSIG
*Note: Discharge Tube Assembly Compressor Unloader Pressure Switch forces unit to run in Low–Stage					
Liquid Line Connection Size in. (mm)	3/8 (10)	3/8 (10)	3/8 (10)	3/8 (10)	
Vapor Line Connection Size in. (mm)	5/8 (16)	3/4 (19)	7/8 (22)	7/8 (22)	
Recommended Line Set Liquid Tube Diameter in. (mm)	3/8 (10)	3/8 (10)	3/8 (10)	3/8 (10)	
Recommended Line Set Vapor Tube Diameter in. (mm)*	5/8 (16)*	3/4 (19)*	7/8 (22)*	1 1/8 (29)*	
* Recommended Vapor Tube Line size is for standard installations. These recommendations may not apply to “Long Line” installations. When the total equivalent line length exceeds 80 feet (24.4m) or there is more than 20 feet (6.1m) vertical separation between indoor and outdoor units, consult the Long Line Application Guideline document before purchasing/installing line sets.					
Factory Charge R–410A lbs. (kg)	14.40 (6.53)	14.60 (6.62)	15.00 (6.8)	14.30 (6.49)	
Required Subcooling ° F (° C)	14 (8)	14 (8)	13 (7)	12 (7)	
Outdoor Unit Factory Piston Size (used in Outdoor Unit for heating mode)	40	59	61	67	
Weight, shipping lbs. (kg)	309 (140)	326 (148)	329 (149)	350 (159)	
Weight, operating lbs. (kg)	266 (121)	279 (127)	286 (130)	308 (140)	

ELECTRICAL DATA (208/230–1–60, voltage range 197V – 253V)

Model Size	24	36	48	60
Minimum Circuit Ampacity – MCA (amps)	13.5	22.1	31.5	35.6
Maximum OverCurrent Protective device – MOCP (amps)	20	35	50	60
Compressor RLA (Rated Load Amps)	10.3	17.1	24.1	27.4
LRA (Locked Rotor Amps)	52.0	82.0	96.0	118.0
Fan Motor FLA (Full Load Amps)	0.7	0.7	1.4	1.4

R-410A COOLING CAPACITY LOSS FOR VARIOUS LINE LENGTHS & TUBE DIAMETERS

Model Size	Liquid Line in.(mm)	Acceptable Vapor Line Sizes in. (mm)	Cooling Capacity Loss (%) at Total Equivalent Line Length, feet (m) Refer to Long Line Application Guideline to calculate equivalent length										
			Standard Application			Long Line Application (Requires Accessories)							
			25' (7.6)	50' (15.2)	80' (24.4)	81' (24.7)	100' (30.5)	125' (38.1)	150' (45.7)	175' (53.3)	200' (61)	225' (68.6)	250' (76.2)
24	3/8 (10)	5/8 (16)	0	1	1	1	2	3	3	4	4	5	6
		3/4 (19)	0	1	1	1	1	1	1	2	2	2	2
36		5/8 (16)	1	2	4	4	5	6	7	9	10	11	13
		3/4 (19)	0	0	1	1	1	2	2	3	3	4	4
48		7/8 (22)	0	0	0	---	---	---	---	---	---	---	---
		3/4 (19)	0	1	2	2	3	4	5	5	6	7	8
		7/8 (22)	0	0	1	1	1	2	2	2	3	3	4
60		3/4 (19)	1	2	4	4	5	6	7	9	10	11	12
	7/8 (22)	0	1	2	2	2	3	4	4	5	5	6	
		1 1/8 (29)	0	0	0	---	---	---	---	---	---	---	

(—) Dashes indicate insufficient oil return to the compressor in heating mode. Use smaller tube diameter.

* Applications are considered "Long Line" if the total equivalent tubing length exceeds 80 feet (24.4m) or there is more than 20 foot (6.1m) vertical separation between indoor and outdoor units. These applications require additional accessories and system modifications for reliable system operation.

Applications in shaded area may have height restrictions that limit allowable total equivalent length when outdoor unit is below indoor unit.

ACCESSORY USAGE GUIDELINES		
Accessory	REQUIRED FOR APPLICATIONS IN SNOW-BELT REGION	REQUIRED FOR LONG-LINE APPLICATIONS* {Over 80 Ft.(24.4m)}
Evaporator Freeze Thermostat	No	No
Accumulator	Standard (factory installed)	Standard (factory installed)
Support Feet, 4" (102mm) tall	Yes	No
Liquid Line Solenoid Valve	No	See Long-Line Application Guideline

* For Line Set lengths between 80 and 200 ft (24.4 and 61m) horizontal, or more than 20 ft (6.1m) indoor-outdoor vertical separation, refer to the Long Line Application Guideline document.

ACCESSORIES		
Part Number	Description	Used On Model Size
NASA001FS	Evaporator Freeze Thermostat	ALL
NASA001LS	Liquid Line Solenoid Valve, HP, R-22 or R-410A	ALL
NASA001TD	Time Delay Relay, Indoor Blower	ALL
NASA001AC	Anti-Cycle Timer (5 minute delay)	ALL
NASA001SF	Support Feet, 4" (102mm) tall	ALL
NASA00106SS	Snow Stand Kit	ALL
EBAC05TXVX	TXV Kit, R-410A *	24
EBAC06TXVX	TXV Kit, R-410A *	36
EBAC07TXVX	TXV Kit, R-410A *	48, 60
Suggested Thermostats To Fully Optimize Two-Stage Heat Pump		
TSTAT0406	4-Wire Capability with Daughter Board	ALL
TSTAT0407	Humidity Control, 4-Wire Capability with Daughter Board	
All Thermostats Feature: Energy Star®, 7-Day Programming, Dual Fuel System Management, 3-Stage Heat, 2-Stage Cool, Auto Changeover, Digital Dealer Contact Info Display, Blue Backlit Display		
<i>Refer to Thermostat Product Specifications literature for complete details</i>		

* ONLY converts Fan Coils equipped with factory installed R-22 TXV.

COOLING & HEATING PERFORMANCE FOR COMBINATION RATINGS Indoor Models

Outdoor Model	Current Indoor Model († tested combo)	Furnace Model	Factory Installed (Field Installed)	Cool 95° F (35° C)						Heat 47° F (8.3° C)				Heat 17° F (-8.3° C)				HSPF	
				High Stage			Low Stage			SEER	High Stage		Low Stage		High Stage		Low Stage		
				BTU/hr	S / T	EER	BTU/hr	S / T	BTU/hr		COP	BTU/hr	COP	BTU/hr	COP	BTU/hr	COP		
T4H524GKD	‡FVM4X36****	†	TDR & TXV	23400	0.73	12.40	17600	0.72	15.50	23600	3.36	17800	3.34	13600	2.62	5700	1.38	8.50	
	ED*4X30B**	*8MPV050	TDR & TXV	23400	0.73	11.60	17800	0.72	14.50	24000	3.22	18000	3.28	14000	2.50	5900	1.38	8.20	
	ED*4X30B**	MV08B15**B*	TDR & TXV	23200	0.73	12.30	17600	0.72	15.00	23400	3.30	17600	3.26	13600	2.58	5700	1.38	8.10	
	ED*4X30B**	†	TDR & TXV	22800	0.73	10.90	17000	0.72	13.00	23600	3.24	17900	3.10	13900	2.42	5800	1.24	7.70	
	ED*4X30F**	*8MPV075	TDR & TXV	23800	0.73	12.10	18000	0.72	15.00	23800	3.26	17800	3.32	13900	2.56	5900	1.40	8.20	
	ED*4X30F**	*9MPV050	TDR & TXV	23400	0.73	11.90	17600	0.72	15.00	23800	3.24	17800	3.26	13800	2.52	5800	1.36	8.20	
	ED*4X30F**	*9MPV075	TDR & TXV	23400	0.73	11.90	17800	0.72	15.00	23800	3.24	17800	3.28	13900	2.54	5900	1.38	8.20	
	ED*4X30F**	*9MVX040	TDR & TXV	23400	0.73	11.80	17600	0.72	15.00	23800	3.24	17800	3.26	13800	2.52	5800	1.36	8.00	
	ED*4X30F**	*9MVX060	TDR & TXV	23600	0.73	11.90	17800	0.72	15.00	23800	3.24	17800	3.30	13900	2.54	5900	1.38	8.10	
	ED*4X30F**	MV12F19**B*	TDR & TXV	23400	0.73	12.40	17600	0.72	15.00	23400	3.30	17600	3.24	13600	2.58	5700	1.36	8.00	
	ED*4X30F**	†	TDR & TXV	22800	0.73	10.90	17000	0.72	13.00	23600	3.24	17800	3.10	13900	2.42	5800	1.24	7.70	
	ED*4X36B**	*8MPV050	TDR & TXV	23600	0.73	11.70	18000	0.72	15.00	24000	3.24	18000	3.32	14000	2.52	5900	1.38	8.20	
	ED*4X36B**	*8MPV075	TDR & TXV	23600	0.73	12.10	18000	0.72	15.00	23800	3.28	17800	3.34	13900	2.58	5800	1.40	8.20	
	ED*4X36B**	*9MPV050	TDR & TXV	23400	0.73	11.80	17600	0.72	15.00	23800	3.26	17800	3.28	13800	2.54	5800	1.36	8.20	
	ED*4X36B**	*9MPV075	TDR & TXV	23400	0.73	11.80	17800	0.72	15.00	23800	3.26	17800	3.30	13900	2.54	5900	1.38	8.20	
	ED*4X36B**	MV08B15**B*	TDR & TXV	23400	0.73	12.40	17600	0.72	15.50	23600	3.32	17600	3.30	13600	2.60	5700	1.38	8.10	
	ED*4X36B**	†	TDR & TXV	22800	0.73	10.90	17200	0.72	13.00	23600	3.26	17800	3.12	13900	2.44	5800	1.24	7.80	
	ED*4X36F**	*8MPV050	TDR & TXV	23600	0.73	11.70	18000	0.72	15.00	24000	3.24	18000	3.32	14000	2.54	5900	1.40	8.20	
	ED*4X36F**	*8MPV075	TDR & TXV	23800	0.73	12.10	18000	0.72	15.00	23800	3.28	18000	3.36	13900	2.58	5900	1.40	8.30	
	ED*4X36F**	*8MPV100	TDR & TXV	24200	0.73	12.30	18400	0.72	15.50	23800	3.30	18000	3.40	13900	2.62	5900	1.44	8.40	
	ED*4X36F**	*9MPV050	TDR & TXV	23400	0.73	11.90	17800	0.72	15.00	23800	3.26	17800	3.32	13800	2.56	5800	1.38	8.20	
	ED*4X36F**	*9MPV075	TDR & TXV	23600	0.73	11.90	18000	0.72	15.00	23800	3.26	18000	3.32	13900	2.56	5900	1.38	8.20	
	ED*4X36F**	*9MPV100	TDR & TXV	24000	0.73	12.10	18000	0.72	15.00	23800	3.28	18000	3.34	13900	2.58	5900	1.40	8.20	
	ED*4X36F**	*9MVX040	TDR & TXV	23400	0.73	11.90	17600	0.72	15.00	23800	3.26	17800	3.30	13900	2.54	5800	1.36	8.10	
	ED*4X36F**	*9MVX060	TDR & TXV	23600	0.73	12.00	18000	0.72	15.00	23800	3.26	18000	3.32	13900	2.56	5900	1.38	8.20	
	ED*4X36F**	MV12F19**B*	TDR & TXV	23400	0.73	12.40	17600	0.72	15.00	23600	3.32	17600	3.28	13600	2.62	5700	1.36	8.10	
	ED*4X36F**	†	TDR & TXV	22800	0.73	10.90	17200	0.72	13.00	23600	3.26	17800	3.12	13900	2.44	5800	1.24	7.80	
	ED*4X36J**	*8MPV075	TDR & TXV	24000	0.73	12.20	18200	0.72	15.50	23800	3.30	18000	3.38	13900	2.60	5900	1.42	8.30	
	ED*4X36J**	*9MPV050	TDR & TXV	23600	0.73	12.00	17800	0.72	15.00	23800	3.28	17800	3.32	13800	2.56	5800	1.38	8.20	
	ED*4X36J**	*9MPV075	TDR & TXV	23600	0.73	12.00	18000	0.72	15.00	23800	3.26	18000	3.34	13900	2.56	5900	1.40	8.20	
ED*4X36J**	†	TDR & TXV	22800	0.73	10.90	17200	0.72	13.00	23600	3.26	17800	3.12	13900	2.44	5800	1.24	7.80		
EHD4X30A**	*8MPV050	TDR & TXV	23600	0.73	11.70	17800	0.72	15.00	24000	3.22	18000	3.30	14000	2.52	5900	1.38	8.20		
EHD4X30A**	*8MPV075	TDR & TXV	23600	0.73	12.00	17800	0.72	15.00	23800	3.28	17800	3.30	13900	2.56	5800	1.38	8.20		

2008 ENERGY STAR compliance for combinations with all three: SEER 14.0 or higher and EER 11.5 or higher and HSPF 8.2 or higher.

† For coils not listed with a matching furnace or blower, coil rating applies with any indoor blower device.

– continued on next page –

COOLING & HEATING PERFORMANCE FOR COMBINATION RATINGS (continued)
Indoor Models

Outdoor Model	Current Indoor Model (‡ tested combo)	Furnace Model	Factory Installed (Field Installed)	Cool 95° F (35° C)						Heat 47° F (8.3° C)				Heat 17° F (-8.3° C)				HSPF	
				High Stage			Low Stage			SEER	High Stage		Low Stage		High Stage		Low Stage		
				BTU/hr	S / T	EER	BTU/hr	S / T	BTU/hr		COP	BTU/hr	COP	BTU/hr	COP	BTU/hr	COP		
T4H524GKD (continued)	EHD4X30A**	*8MPV100	TDR & TXV	24000	0.73	12.20	18000	0.72	15.00	23800	3.30	17800	3.34	13900	2.60	5900	1.40	8.30	
	EHD4X30A**	*8MPV125	TDR & TXV	24000	0.73	12.30	18200	0.72	15.00	23800	3.30	18000	3.36	13900	2.60	5900	1.40	8.30	
	EHD4X30A**	*9MPV050	TDR & TXV	23400	0.73	11.80	17600	0.72	15.00	23800	3.24	17800	3.26	13800	2.52	5800	1.36	8.20	
	EHD4X30A**	*9MPV075	TDR & TXV	23400	0.73	11.80	17800	0.72	15.00	23800	3.24	17800	3.28	13900	2.54	5800	1.36	8.20	
	EHD4X30A**	*9MPV100	TDR & TXV	23800	0.73	12.00	17800	0.72	15.00	23800	3.26	17800	3.28	13900	2.56	5800	1.38	8.20	
	EHD4X30A**	*9MPV125	TDR & TXV	23800	0.73	12.10	18000	0.72	15.00	23800	3.28	17800	3.34	13900	2.58	5800	1.40	8.20	
	EHD4X30A**	*9MVX040	TDR & TXV	23400	0.73	11.80	17600	0.72	15.00	23800	3.24	17800	3.24	13900	2.52	5800	1.34	8.00	
	EHD4X30A**	*9MVX060	TDR & TXV	23600	0.73	11.90	17800	0.72	15.00	23800	3.24	17800	3.28	13900	2.54	5800	1.36	8.10	
	EHD4X30A**	*9MVX080	TDR & TXV	24000	0.73	12.10	18200	0.72	15.00	23800	3.26	18000	3.34	13900	2.58	5900	1.40	8.20	
	EHD4X30A**	*9MVX100	TDR & TXV	23800	0.73	12.10	18000	0.72	15.00	23800	3.28	17900	3.32	13900	2.58	5800	1.38	8.20	
	EHD4X30A**	MV08B15**B*	TDR & TXV	23400	0.73	12.30	17600	0.72	15.50	23600	3.30	17600	3.28	13600	2.60	5700	1.38	8.10	
	EHD4X30A**	MV12F19**B*	TDR & TXV	23400	0.73	12.40	17600	0.72	15.00	23600	3.32	17600	3.26	13600	2.60	5700	1.36	8.10	
	EHD4X30A**	†	TDR & TXV	22800	0.73	11.00	17200	0.72	13.00	23600	3.26	17800	3.10	13900	2.44	5800	1.24	7.80	
	EHD4X36A**	*8MPV050	TDR & TXV	24000	0.73	11.90	18200	0.72	15.00	24000	3.26	18000	3.38	14100	2.58	5900	1.40	8.30	
	EHD4X36A**	*8MPV075	TDR & TXV	24200	0.73	12.30	18200	0.72	15.50	23800	3.32	18000	3.42	13900	2.64	5900	1.42	8.40	
	EHD4X36A**	*9MPV050	TDR & TXV	23800	0.73	12.10	17800	0.72	15.00	23800	3.30	18000	3.36	13900	2.60	5800	1.38	8.30	
	EHD4X36A**	*9MPV075	TDR & TXV	23800	0.73	12.10	18000	0.72	15.00	24000	3.30	18000	3.38	14000	2.60	5900	1.38	8.30	
	EHD4X36A**	*9MPV100	TDR & TXV	24200	0.73	12.30	18200	0.72	15.00	24000	3.30	18000	3.38	14000	2.62	5900	1.40	8.40	
	EHD4X36A**	*9MPV125	TDR & TXV	24400	0.73	12.40	18400	0.72	15.50	23800	3.32	18000	3.42	13900	2.64	5900	1.44	8.40	
	EHD4X36A**	*9MVX040	TDR & TXV	23800	0.73	12.00	17800	0.72	15.00	23800	3.30	18000	3.36	13900	2.60	5800	1.38	8.20	
	EHD4X36A**	*9MVX060	TDR & TXV	24000	0.73	12.10	18000	0.72	15.00	24000	3.30	18000	3.38	14000	2.60	5900	1.40	8.30	
	EHD4X36A**	*9MVX080	TDR & TXV	24400	0.73	12.40	18600	0.72	15.50	24000	3.30	18100	3.42	14000	2.64	5900	1.44	8.40	
	EHD4X36A**	*9MVX100	TDR & TXV	24400	0.73	12.40	18200	0.72	15.50	23800	3.32	18000	3.42	13900	2.66	5900	1.42	8.40	
	EHD4X36A**	MV08B15**B*	TDR & TXV	23600	0.73	12.50	17800	0.72	15.50	23600	3.38	17800	3.38	13700	2.66	5700	1.38	8.30	
EHD4X36A**	MV12F19**B*	TDR & TXV	23800	0.73	12.60	17800	0.72	15.50	23600	3.38	17800	3.36	13700	2.66	5700	1.38	8.30		
EHD4X36A**	†	TDR & TXV	23200	0.73	11.10	17400	0.72	13.00	23800	3.32	18000	3.20	13900	2.48	5900	1.24	7.90		
FVM4X24***	†	TDR & TXV	23200	0.73	12.20	17600	0.72	15.00	23200	3.52	17600	3.42	13500	2.64	5500	1.36	8.40		
T4H736GKD	‡FVM4X60****	†	TDR & TXV	35400	0.73	13.10	25400	0.76	17.50	36000	4.10	24200	4.10	21200	2.98	13700	2.46	9.50	
	ED*4X36B**	*8MPV050	TDR & TXV	33000	0.73	11.30	24200	0.76	15.00	36000	3.54	24200	3.68	21600	2.64	13900	2.26	8.50	
	ED*4X36B**	†	TDR & TXV	33200	0.73	11.30	24000	0.76	14.00	36000	3.56	24600	3.54	21800	2.64	14400	2.18	8.30	
	ED*4X36B**	MV08B15**B*	TDR & TXV	33600	0.73	12.20	24600	0.76	16.50	35600	3.72	24000	3.84	21200	2.78	13700	2.34	8.80	
	ED*4X36F**	*8MPV075	TDR & TXV	33800	0.73	11.90	24600	0.76	16.00	36000	3.72	24200	3.82	21400	2.76	13900	2.32	8.80	
	ED*4X36F**	*9MPV050	TDR & TXV	33200	0.73	11.40	24200	0.76	15.50	36200	3.60	24000	3.72	21600	2.68	13900	2.28	8.60	

2008 ENERGY STAR compliance for combinations with all three: SEER 14.0 or higher and EER 11.5 or higher and HSPF 8.2 or higher.

† For coils not listed with a matching furnace or blower, coil rating applies with any indoor blower device.

- continued on next page -

COOLING & HEATING PERFORMANCE FOR COMBINATION RATINGS (continued)
Indoor Models

Outdoor Model	Current Indoor Model († tested combo)	Furnace Model	Factory Installed (Field Installed)	Cool 95° F (35° C)						Heat 47° F (8.3° C)				Heat 17° F (-8.3° C)				HSPF	
				High Stage			Low Stage			SEER	High Stage		Low Stage		High Stage		Low Stage		
				BTU/hr	S / T	EER	BTU/hr	S / T	BTU/hr		COP	BTU/hr	COP	BTU/hr	COP	BTU/hr	COP		
T4H736GKD (continued)	ED*4X36F**	*9MPV075	TDR & TXV	33400	0.73	11.60	24200	0.76	15.50	36000	3.64	24200	3.72	21600	2.70	13900	2.28	8.60	
	ED*4X36F**	†	TDR & TXV	33200	0.73	11.30	24000	0.76	14.00	36000	3.56	24600	3.54	21800	2.64	14400	2.18	8.30	
	ED*4X36F**	*9MVX040	TDR & TXV	33200	0.73	11.40	24200	0.76	15.50	36200	3.58	24000	3.68	21600	2.66	13900	2.26	8.50	
	ED*4X36F**	*9MVX060	TDR & TXV	33600	0.73	11.60	24200	0.76	15.50	36200	3.68	23800	3.70	21600	2.72	13700	2.28	8.60	
	ED*4X36F**	MV12F19**B*	TDR & TXV	33800	0.73	12.50	24600	0.76	16.50	35400	3.78	23800	3.88	21000	2.82	13600	2.36	8.90	
	ED*4X36J**	*8MPV100	TDR & TXV	34200	0.73	12.20	25000	0.76	16.50	36200	3.84	24400	3.96	21400	2.82	13900	2.38	9.00	
	ED*4X36J**	*9MPV100	TDR & TXV	34000	0.73	12.00	24800	0.76	16.00	36200	3.80	24400	3.92	21600	2.80	14000	2.36	9.00	
	ED*4X36J**	†	TDR & TXV	33200	0.73	11.30	24000	0.76	14.00	36000	3.56	24600	3.54	21800	2.64	14400	2.18	8.30	
	ED*4X36J**	*9MVX080	TDR & TXV	34200	0.73	12.00	24800	0.76	16.00	36400	3.82	24400	3.92	21600	2.80	14000	2.36	9.00	
	ED*4X36J**	MV16J22**B*	TDR & TXV	33800	0.73	12.60	24600	0.76	16.50	35400	3.80	23800	3.86	21000	2.84	13600	2.36	8.90	
	ED*4X42F**	*8MPV075	TDR & TXV	34000	0.73	12.00	24000	0.76	16.00	36000	3.78	24400	3.88	21600	2.78	13900	2.34	9.00	
	ED*4X42F**	*9MPV050	TDR & TXV	33600	0.73	11.50	24000	0.76	15.50	36000	3.66	24200	3.76	21800	2.70	13900	2.30	8.70	
	ED*4X42F**	*9MPV075	TDR & TXV	33800	0.73	11.70	24000	0.76	15.50	36000	3.70	24200	3.78	21600	2.72	13900	2.30	8.70	
	ED*4X42F**	†	TDR & TXV	33400	0.73	11.30	24000	0.76	14.00	36000	3.60	24600	3.58	21800	2.66	14400	2.20	8.40	
	ED*4X42F**	*9MVX040	TDR & TXV	33600	0.73	11.50	24400	0.76	15.50	36200	3.66	24200	3.74	21600	2.70	13900	2.28	8.60	
	ED*4X42F**	*9MVX060	TDR & TXV	33800	0.73	11.70	24400	0.76	16.00	36200	3.74	24000	3.76	21600	2.74	13700	2.30	8.70	
	ED*4X42F**	MV12F19**B*	TDR & TXV	34200	0.73	12.60	24800	0.76	16.50	35600	3.84	24000	3.92	21000	2.86	13600	2.38	9.00	
	ED*4X42J**	*8MPV100	TDR & TXV	34600	0.73	12.20	25000	0.76	16.50	36400	3.90	24400	4.00	21600	2.84	14000	2.40	9.20	
	ED*4X42J**	*8MPV125	TDR & TXV	34600	0.73	12.40	25000	0.76	16.50	36200	3.90	24200	3.98	21400	2.86	13900	2.38	9.10	
	ED*4X42J**	*9MPV100	TDR & TXV	34400	0.73	12.10	25000	0.76	16.00	36400	3.86	24400	3.96	21600	2.82	14000	2.38	9.10	
	ED*4X42J**	†	TDR & TXV	33400	0.73	11.30	24000	0.76	14.00	36000	3.60	24600	3.58	21800	2.66	14400	2.20	8.40	
	ED*4X42J**	*9MVX080	TDR & TXV	34400	0.73	12.10	25000	0.76	16.00	36400	3.86	24400	3.96	21600	2.82	14000	2.38	9.00	
	ED*4X42J**	MV16J22**B*	TDR & TXV	34200	0.73	12.60	24800	0.76	16.50	35600	3.86	24000	3.90	21000	2.86	13600	2.38	8.90	
	ED*4X42L**	*9MPV125	TDR & TXV	34400	0.73	12.30	25000	0.76	16.50	36200	3.90	24400	3.96	21400	2.84	14000	2.38	9.10	
	ED*4X42L**	†	TDR & TXV	33400	0.73	11.30	24000	0.76	14.00	36000	3.60	24600	3.58	21800	2.66	14400	2.20	8.40	
	ED*4X42L**	*9MVX100	TDR & TXV	34400	0.73	12.30	24800	0.76	16.50	36200	3.86	24200	3.94	21400	2.84	13900	2.38	9.00	
	ED*4X42L**	MV20L24**B*	TDR & TXV	34200	0.73	12.70	24800	0.76	16.50	35600	3.86	24000	3.90	21000	2.86	13700	2.36	8.90	
	ED*4X48F**	*8MPV050	TDR & TXV	34200	0.73	11.70	25000	0.76	16.00	36800	3.80	24600	3.88	21800	2.76	14100	2.34	8.90	
	ED*4X48F**	*8MPV075	TDR & TXV	34800	0.73	12.20	25200	0.76	16.50	36800	3.96	24600	4.02	21800	2.86	14100	2.40	9.20	
	ED*4X48F**	*8MPV100	TDR & TXV	35200	0.73	12.40	25400	0.76	16.50	37000	4.08	24800	4.10	21800	2.92	14100	2.44	9.20	
ED*4X48F**	*8MPV125	TDR & TXV	35200	0.73	12.60	25400	0.76	17.00	36800	4.08	24600	4.08	21600	2.92	14000	2.42	9.30		
ED*4X48F**	*9MPV050	TDR & TXV	34400	0.73	11.70	24800	0.76	16.00	36800	3.84	24400	3.88	22000	2.76	14000	2.34	8.80		
ED*4X48F**	*9MPV075	TDR & TXV	34600	0.73	11.90	25000	0.76	16.00	36800	3.88	24600	3.90	21800	2.80	14100	2.34	9.00		

2008 ENERGY STAR compliance for combinations with all three: SEER 14.0 or higher and EER 11.5 or higher and HSPF 8.2 or higher.

† For coils not listed with a matching furnace or blower, coil rating applies with any indoor blower device.

- continued on next page -

COOLING & HEATING PERFORMANCE FOR COMBINATION RATINGS (continued) Indoor Models

Outdoor Model	Current Indoor Model (‡ tested combo)	Furnace Model	Factory Installed (Field Installed)	Cool 95° F (35° C)						Heat 47° F (8.3° C)				Heat 17° F (-8.3° C)				HSPF	
				High Stage			Low Stage			SEER	High Stage		Low Stage		High Stage		Low Stage		
				BTU/hr	S / T	EER	BTU/hr	S / T	BTU/hr		COP	BTU/hr	COP	BTU/hr	COP	BTU/hr	COP		
T4H736GKD (continued)	ED*4X48F**	*9MPV100	TDR & TXV	35000	0.73	12.30	25400	0.76	16.50	36800	4.02	24600	4.06	21800	2.88	14100	2.42	9.10	
	ED*4X48F**	†	TDR & TXV	34200	0.73	11.60	24600	0.76	14.50	36000	3.78	25000	3.68	22000	2.74	14500	2.24	8.50	
	ED*4X48F**	*9MVX040	TDR & TXV	34400	0.73	11.70	24800	0.76	16.00	36800	3.82	24400	3.86	21800	2.76	14000	2.34	8.70	
	ED*4X48F**	*9MVX060	TDR & TXV	34800	0.73	12.00	24800	0.76	16.00	36800	3.92	24200	3.86	21800	2.82	13800	2.34	8.80	
	ED*4X48F**	MV12F19**B*	TDR & TXV	35000	0.73	12.80	25200	0.76	17.00	36200	4.04	24200	4.04	21200	2.92	13700	2.42	9.20	
	ED*4X48J**	*8MPV075	TDR & TXV	34600	0.73	12.20	25200	0.76	16.50	36600	3.94	24600	4.00	21600	2.84	14000	2.40	9.20	
	ED*4X48J**	*8MPV100	TDR & TXV	35200	0.73	12.40	25400	0.76	16.50	36800	4.04	24600	4.10	21600	2.90	14100	2.44	9.20	
	ED*4X48J**	*8MPV125	TDR & TXV	35200	0.73	12.50	25400	0.76	17.00	36600	4.06	24600	4.08	21600	2.92	14000	2.44	9.30	
	ED*4X48J**	*9MPV050	TDR & TXV	34200	0.73	11.70	24800	0.76	16.00	36800	3.80	24400	3.86	21800	2.76	14000	2.34	8.90	
	ED*4X48J**	*9MPV075	TDR & TXV	34400	0.73	11.90	24800	0.76	16.00	36600	3.84	24400	3.88	21800	2.78	14100	2.34	8.90	
	ED*4X48J**	*9MPV100	TDR & TXV	35000	0.73	12.30	25200	0.76	16.50	36800	4.00	24600	4.06	21800	2.88	14100	2.42	9.10	
	ED*4X48J**	*9MPV125	TDR & TXV	35000	0.73	12.40	25200	0.76	16.50	36600	4.02	24600	4.06	21600	2.90	14000	2.42	9.30	
	ED*4X48J**	†	TDR & TXV	34000	0.73	11.50	24400	0.76	14.50	36000	3.72	24800	3.64	21800	2.72	14500	2.22	8.50	
	ED*4X48J**	*9MVX080	TDR & TXV	35000	0.73	12.30	25400	0.76	16.50	36800	4.02	24600	4.06	21800	2.88	14100	2.42	9.10	
	ED*4X48J**	MV16J22**B*	TDR & TXV	34600	0.73	12.80	25000	0.76	17.00	35800	3.98	24200	4.00	21000	2.92	13700	2.40	9.10	
	ED*4X48L**	*8MPV100	TDR & TXV	35200	0.73	12.40	25400	0.76	16.50	36800	4.06	24600	4.10	21600	2.92	14100	2.44	9.20	
	ED*4X48L**	*8MPV125	TDR & TXV	35200	0.73	12.60	25200	0.76	17.00	36600	4.06	24400	4.08	21600	2.92	13900	2.42	9.30	
	ED*4X48L**	*9MPV100	TDR & TXV	35000	0.73	12.30	25200	0.76	16.50	36800	4.00	24600	4.06	21800	2.88	14100	2.42	9.10	
	ED*4X48L**	*9MPV125	TDR & TXV	35000	0.73	12.40	25200	0.76	16.50	36600	4.02	24600	4.04	21600	2.90	14000	2.42	9.30	
	ED*4X48L**	†	TDR & TXV	34000	0.73	11.50	24400	0.76	14.50	36000	3.72	24800	3.64	21800	2.72	14500	2.22	8.50	
	ED*4X48L**	*9MVX100	TDR & TXV	34800	0.73	12.40	25200	0.76	16.50	36600	3.98	24400	4.02	21600	2.88	14000	2.40	9.20	
	ED*4X48L**	MV20L24**B*	TDR & TXV	34600	0.73	12.80	25000	0.76	17.00	35800	3.98	24200	3.98	21000	2.92	13800	2.40	9.10	
	EHD4X36A**	*8MPV050	TDR & TXV	34000	0.73	11.60	24600	0.76	15.50	36400	3.70	24400	3.80	21800	2.72	14000	2.30	8.80	
	EHD4X36A**	*8MPV075	TDR & TXV	34600	0.73	12.10	25000	0.76	16.00	36400	3.86	24400	3.92	21600	2.82	14000	2.36	9.00	
EHD4X36A**	*8MPV100	TDR & TXV	35000	0.73	12.30	25200	0.76	16.50	36600	3.96	24600	4.02	21600	2.86	14000	2.40	9.20		
EHD4X36A**	*8MPV125	TDR & TXV	35000	0.73	12.50	25000	0.76	16.50	36400	3.96	24400	3.98	21400	2.88	13900	2.40	9.10		
EHD4X36A**	*9MPV050	TDR & TXV	34200	0.73	11.70	24600	0.76	15.50	36600	3.74	24200	3.80	21800	2.74	13900	2.30	8.80		
EHD4X36A**	*9MPV075	TDR & TXV	34200	0.73	11.80	24600	0.76	15.50	36400	3.76	24400	3.80	21600	2.76	14000	2.32	8.80		
EHD4X36A**	*9MPV100	TDR & TXV	34800	0.73	12.20	25000	0.76	16.00	36600	3.90	24400	3.96	21600	2.84	14000	2.38	9.10		
EHD4X36A**	*9MPV125	TDR & TXV	34800	0.73	12.30	25000	0.76	16.50	36400	3.94	24400	3.96	21600	2.86	14000	2.38	9.10		
EHD4X36A**	†	TDR & TXV	34000	0.73	11.50	24400	0.76	14.50	36000	3.70	24800	3.62	21800	2.70	14500	2.22	8.50		
EHD4X36A**	*9MVX040	TDR & TXV	34000	0.73	11.60	24600	0.76	15.50	36600	3.72	24200	3.76	21800	2.72	14000	2.30	8.70		
EHD4X36A**	*9MVX060	TDR & TXV	34400	0.73	11.90	24600	0.76	16.00	36600	3.82	24000	3.78	21800	2.78	13700	2.30	8.70		

2008 ENERGY STAR compliance for combinations with all three: SEER 14.0 or higher and EER 11.5 or higher and HSPF 8.2 or higher.

† For coils not listed with a matching furnace or blower, coil rating applies with any indoor blower device.

– continued on next page –

COOLING & HEATING PERFORMANCE FOR COMBINATION RATINGS (continued) Indoor Models

Outdoor Model	Current Indoor Model (‡ tested combo)	Furnace Model	Factory Installed (Field Installed)	Cool 95° F (35° C)						Heat 47° F (8.3° C)				Heat 17° F (-8.3° C)				HSPF	
				High Stage			Low Stage			SEER	High Stage		Low Stage		High Stage		Low Stage		
				BTU/hr	S / T	EER	BTU/hr	S / T	BTU/hr		COP	BTU/hr	COP	BTU/hr	COP	BTU/hr	COP		
T4H736GKD (continued)	EHD4X36A**	*9MVX080	TDR & TXV	35000	0.73	12.20	25200	0.76	16.50	36800	3.94	24600	3.98	21800	2.84	14100	2.38	9.10	
	EHD4X36A**	*9MVX100	TDR & TXV	34600	0.73	12.30	25000	0.76	16.50	36400	3.90	24400	3.94	21400	2.84	13900	2.38	9.00	
	EHD4X36A**	MV08B15**B*	TDR & TXV	34600	0.73	12.50	25000	0.76	16.50	36000	3.90	24200	3.94	21200	2.86	13800	2.38	9.00	
	EHD4X36A**	MV12F19**B*	TDR & TXV	34600	0.73	12.70	25000	0.76	17.00	35800	3.92	24000	3.96	21200	2.88	13700	2.40	9.10	
	EHD4X36A**	MV16J22**B*	TDR & TXV	34600	0.73	12.70	25000	0.76	17.00	35800	3.94	24200	3.94	21200	2.90	13700	2.38	9.00	
	EHD4X36A**	MV20L24**B*	TDR & TXV	34600	0.73	12.70	25000	0.76	16.50	35800	3.92	24200	3.94	21200	2.88	13800	2.38	9.00	
	EHD4X42A**	*8MPV050	TDR & TXV	34200	0.73	11.70	24800	0.76	15.50	36600	3.76	24400	3.84	21800	2.74	14100	2.32	8.80	
	EHD4X42A**	*8MPV075	TDR & TXV	34800	0.73	12.20	25200	0.76	16.50	36600	3.92	24600	3.98	21600	2.84	14000	2.38	9.10	
	EHD4X42A**	*8MPV100	TDR & TXV	35200	0.73	12.50	25400	0.76	16.50	36800	4.04	24600	4.06	21600	2.90	14000	2.42	9.20	
	EHD4X42A**	*8MPV125	TDR & TXV	35200	0.73	12.60	25200	0.76	17.00	36600	4.04	24400	4.04	21600	2.92	13900	2.42	9.30	
	EHD4X42A**	*9MPV050	TDR & TXV	34400	0.73	11.70	24800	0.76	16.00	36600	3.78	24400	3.84	21800	2.76	14000	2.32	8.90	
	EHD4X42A**	*9MPV075	TDR & TXV	34400	0.73	11.90	24800	0.76	16.00	36600	3.82	24400	3.84	21800	2.78	14000	2.34	8.90	
	EHD4X42A**	*9MPV100	TDR & TXV	35000	0.73	12.30	25400	0.76	16.50	36800	3.98	24600	4.02	21800	2.86	14100	2.40	9.20	
	EHD4X42A**	*9MPV125	TDR & TXV	35200	0.73	12.40	25200	0.76	16.50	36600	4.00	24600	4.02	21600	2.90	14000	2.40	9.20	
	EHD4X42A**	†	TDR & TXV	34200	0.73	11.60	24400	0.76	14.50	36000	3.74	24800	3.64	22000	2.72	14500	2.22	8.50	
	EHD4X42A**	*9MVX040	TDR & TXV	34400	0.73	11.70	24800	0.76	16.00	36600	3.78	24400	3.82	21800	2.74	14000	2.32	8.80	
	EHD4X42A**	*9MVX060	TDR & TXV	34600	0.73	12.00	24800	0.76	16.00	36800	3.88	24200	3.82	21800	2.80	13800	2.34	8.70	
	EHD4X42A**	*9MVX080	TDR & TXV	35200	0.73	12.30	25400	0.76	16.50	36800	4.00	24600	4.04	21800	2.88	14100	2.40	9.10	
	EHD4X42A**	*9MVX100	TDR & TXV	35000	0.73	12.40	25200	0.76	16.50	36400	3.96	24400	4.00	21600	2.88	13900	2.40	9.10	
	EHD4X42A**	MV08B15**B*	TDR & TXV	34800	0.73	12.60	25000	0.76	17.00	36000	3.94	24200	3.98	21200	2.88	13800	2.40	9.10	
	EHD4X42A**	MV12F19**B*	TDR & TXV	34800	0.73	12.80	25200	0.76	17.00	36000	3.98	24200	4.00	21200	2.92	13700	2.42	9.10	
	EHD4X42A**	MV16J22**B*	TDR & TXV	34800	0.73	12.80	25200	0.76	17.00	36000	3.98	24200	3.98	21200	2.92	13800	2.40	9.10	
	EHD4X42A**	MV20L24**B*	TDR & TXV	34800	0.73	12.80	25000	0.76	17.00	36000	3.98	24200	3.98	21200	2.92	13800	2.40	9.10	
	EHD4X48A**	*8MPV050	TDR & TXV	34400	0.73	11.70	25000	0.76	16.00	36600	3.78	24600	3.86	21800	2.74	14100	2.34	8.90	
	EHD4X48A**	*8MPV075	TDR & TXV	35000	0.73	12.30	25200	0.76	16.50	36600	3.94	24600	4.00	21600	2.86	14000	2.40	9.10	
	EHD4X48A**	*8MPV100	TDR & TXV	35400	0.73	12.50	25600	0.76	17.00	36800	4.06	24600	4.10	21800	2.92	14100	2.44	9.20	
	EHD4X48A**	*8MPV125	TDR & TXV	35400	0.73	12.60	25400	0.76	17.00	36600	4.06	24400	4.06	21600	2.92	13900	2.42	9.30	
	EHD4X48A**	*9MPV050	TDR & TXV	34400	0.73	11.80	24800	0.76	16.00	36800	3.82	24400	3.86	21800	2.76	14000	2.34	8.80	
	EHD4X48A**	*9MPV075	TDR & TXV	34600	0.73	12.00	25000	0.76	16.00	36600	3.86	24400	3.88	21800	2.80	14000	2.34	8.90	
	EHD4X48A**	*9MPV100	TDR & TXV	35200	0.73	12.30	25400	0.76	16.50	36800	4.00	24600	4.04	21800	2.88	14100	2.40	9.10	
EHD4X48A**	*9MPV125	TDR & TXV	35200	0.73	12.50	25400	0.76	16.50	36800	4.04	24600	4.04	21600	2.90	14000	2.42	9.20		
EHD4X48A**		TDR & TXV	34200	0.73	11.60	24600	0.76	14.50	36000	3.76	24800	3.66	22000	2.72	14500	2.24	8.50		
EHD4X48A**	*9MVX040	TDR & TXV	34400	0.73	11.80	24800	0.76	16.00	36800	3.80	24400	3.86	21800	2.76	14000	2.34	8.80		

2008 ENERGY STAR compliance for combinations with all three: SEER 14.0 or higher and EER 11.5 or higher and HSPF 8.2 or higher.

† For coils not listed with a matching furnace or blower, coil rating applies with any indoor blower device.

- continued on next page -

COOLING & HEATING PERFORMANCE FOR COMBINATION RATINGS (continued) Indoor Models

Outdoor Model	Current Indoor Model (‡ tested combo)	Furnace Model	Factory Installed (Field Installed)	Cool 95° F (35° C)						Heat 47° F (8.3° C)				Heat 17° F (-8.3° C)				HSPF	
				High Stage			Low Stage			SEER	High Stage		Low Stage		High Stage		Low Stage		
				BTU/hr	S / T	EER	BTU/hr	S / T	BTU/hr		COP	BTU/hr	COP	BTU/hr	COP	BTU/hr	COP		
T4H736GKD (continued)	EHD4X48A**	*9MVX060	TDR & TXV	34800	0.73	12.00	24800	0.76	16.00	36800	3.90	24200	3.86	21800	2.82	13800	2.34	8.80	
	EHD4X48A**	*9MVX080	TDR & TXV	35400	0.73	12.30	25400	0.76	16.50	37000	4.04	24800	4.06	21800	2.88	14100	2.42	9.10	
	EHD4X48A**	*9MVX100	TDR & TXV	35000	0.73	12.50	25200	0.76	16.50	36600	4.00	24400	4.02	21600	2.88	14000	2.40	9.20	
	EHD4X48A**	MV08B15**B*	TDR & TXV	34800	0.73	12.70	25200	0.76	17.00	36200	3.98	24200	4.00	21200	2.90	13800	2.40	9.10	
	EHD4X48A**	MV12F19**B*	TDR & TXV	35000	0.73	12.90	25200	0.76	17.00	36000	4.00	24200	4.04	21200	2.92	13700	2.42	9.20	
	EHD4X48A**	MV16J22**B*	TDR & TXV	35000	0.73	12.90	25200	0.76	17.00	36000	4.02	24200	4.02	21200	2.92	13800	2.42	9.20	
	EHD4X48A**	MV20L24**B*	TDR & TXV	35000	0.73	12.90	25200	0.76	17.00	36000	4.00	24200	4.00	21200	2.92	13800	2.40	9.10	
	FVM4X24****	†	TDR & TXV	33600	0.73	12.00	24400	0.76	16.00	35800	3.74	24000	3.80	21200	2.76	13700	2.32	8.80	
	FVM4X36****	†	TDR & TXV	33800	0.73	12.40	24600	0.76	16.50	35400	3.76	23800	3.84	21000	2.80	13600	2.34	8.90	
	FVM4X48****	†	TDR & TXV	35000	0.73	13.00	25200	0.76	17.00	36000	4.00	24200	4.02	21200	2.92	13700	2.42	9.20	
T4H548GKD	‡FVM4X60****	†	TDR & TXV	46500	0.73	12.20	34200	0.77	15.50	48000	3.74	34600	3.84	29000	2.78	19200	2.52	9.00	
	ED*4X48F**	†	TDR & TXV	44500	0.73	11.00	32800	0.77	13.00	48000	3.50	35400	3.52	29800	2.60	20000	2.34	8.30	
	ED*4X48J**	*8MPV100	TDR & TXV	45000	0.73	11.30	33400	0.77	14.50	49000	3.54	34800	3.70	29400	2.66	19500	2.44	8.60	
	ED*4X48J**	*8MPV125	TDR & TXV	45000	0.73	11.40	33200	0.77	14.50	49000	3.56	34600	3.68	29400	2.66	19300	2.44	8.60	
	ED*4X48J**	*9MPV100	TDR & TXV	44500	0.73	11.00	33200	0.77	14.00	49500	3.50	34800	3.66	29600	2.62	19500	2.42	8.60	
	ED*4X48J**	*9MVX080	TDR & TXV	44500	0.73	11.00	33200	0.77	14.50	49000	3.50	35000	3.68	29600	2.62	19600	2.44	8.60	
	ED*4X48J**	MV16J22**B*	TDR & TXV	45000	0.73	11.70	33400	0.77	15.00	48500	3.60	34400	3.72	28800	2.72	19100	2.48	8.70	
	ED*4X48J**	†	TDR & TXV	44000	0.73	10.90	32600	0.77	13.00	48000	3.44	35200	3.46	29600	2.58	20000	2.32	8.20	
	ED*4X48L**	*9MPV125	TDR & TXV	44500	0.73	11.20	33200	0.77	14.50	49000	3.52	34800	3.66	29400	2.64	19400	2.44	8.60	
	ED*4X48L**	*9MVX100	TDR & TXV	44500	0.73	11.20	33200	0.77	14.50	49000	3.52	34600	3.66	29400	2.64	19400	2.42	8.50	
	ED*4X48L**	MV20L24**B*	TDR & TXV	45000	0.73	11.80	33400	0.77	15.00	48500	3.60	34400	3.72	28800	2.72	19100	2.48	8.70	
	ED*4X48L**	†	TDR & TXV	44000	0.73	10.90	32600	0.77	13.00	48000	3.44	35200	3.46	29600	2.58	20000	2.32	8.20	
	ED*4X60J**	*8MPV100	TDR & TXV	46000	0.73	11.60	34200	0.77	15.00	49000	3.62	35000	3.78	29600	2.70	19500	2.48	8.80	
	ED*4X60J**	*8MPV125	TDR & TXV	46000	0.73	11.70	34000	0.77	15.00	49000	3.64	34800	3.78	29400	2.70	19400	2.48	8.80	
	ED*4X60J**	*9MPV100	TDR & TXV	46000	0.73	11.40	34000	0.77	14.50	49000	3.58	35000	3.74	29800	2.66	19600	2.46	8.70	
	ED*4X60J**	*9MVX080	TDR & TXV	46000	0.73	11.40	34000	0.77	14.50	49000	3.58	35200	3.76	29800	2.66	19600	2.48	8.70	
	ED*4X60J**	MV16J22**B*	TDR & TXV	46000	0.73	12.10	34000	0.77	15.50	48500	3.66	34600	3.80	29000	2.76	19200	2.50	8.80	
	ED*4X60J**	†	TDR & TXV	45000	0.73	11.10	33200	0.77	13.50	48000	3.48	35400	3.50	29800	2.60	20000	2.34	8.30	
	ED*4X60L**	*9MPV125	TDR & TXV	46000	0.73	11.50	33800	0.77	15.00	49000	3.58	35000	3.72	29600	2.66	19500	2.46	8.70	
	ED*4X60L**	*9MVX100	TDR & TXV	45500	0.73	11.50	33800	0.77	15.00	49000	3.56	34800	3.70	29600	2.66	19400	2.46	8.60	
	ED*4X60L**	MV20L24**B*	TDR & TXV	46000	0.73	12.10	34000	0.77	15.50	48500	3.66	34600	3.78	29000	2.74	19200	2.50	8.80	
	ED*4X60L**	†	TDR & TXV	45000	0.73	11.10	33200	0.77	13.50	48000	3.48	35400	3.50	29800	2.60	20000	2.34	8.30	
	EHD4X48A**	*8MPV100	TDR & TXV	45500	0.73	11.40	33600	0.77	14.50	49500	3.56	34800	3.70	29600	2.66	19500	2.44	8.70	

2008 ENERGY STAR compliance for combinations with all three: SEER 14.0 or higher and EER 11.5 or higher and HSPF 8.2 or higher.

† For coils not listed with a matching furnace or blower, coil rating applies with any indoor blower device.

- continued on next page -

COOLING & HEATING PERFORMANCE FOR COMBINATION RATINGS (continued)
Indoor Models

Outdoor Model	Current Indoor Model (‡ tested combo)	Furnace Model	Factory Installed (Field Installed)	Cool 95° F (35° C)						Heat 47° F (8.3° C)				Heat 17° F (-8.3° C)				HSPF	
				High Stage			Low Stage			SEER	High Stage		Low Stage		High Stage		Low Stage		
				BTU/hr	S / T	EER	BTU/hr	S / T	BTU/hr		COP	BTU/hr	COP	BTU/hr	COP	BTU/hr	COP		
T4H548GKD (continued)	EHD4X48A**	*8MPV125	TDR & TXV	45500	0.73	11.50	33400	0.77	15.00	49000	3.58	34600	3.68	29400	2.68	19300	2.44	8.60	
	EHD4X48A**	*9MPV100	TDR & TXV	45000	0.73	11.10	33400	0.77	14.50	49500	3.52	34800	3.66	29600	2.62	19500	2.42	8.60	
	EHD4X48A**	*9MPV125	TDR & TXV	45000	0.73	11.30	33400	0.77	14.50	49500	3.54	34800	3.68	29600	2.64	19500	2.44	8.60	
	EHD4X48A**	*9MVX080	TDR & TXV	45000	0.73	11.20	33600	0.77	14.50	49000	3.52	35000	3.70	29800	2.62	19600	2.44	8.60	
	EHD4X48A**	*9MVX100	TDR & TXV	45000	0.73	11.30	33400	0.77	14.50	49000	3.52	34800	3.66	29400	2.64	19400	2.42	8.50	
	EHD4X48A**	MV16J22**B*	TDR & TXV	45500	0.73	11.90	33600	0.77	15.00	48500	3.64	34600	3.76	29000	2.72	19200	2.48	8.70	
	EHD4X48A**	MV20L24**B*	TDR & TXV	45500	0.73	11.80	33600	0.77	15.00	48500	3.64	34600	3.76	29000	2.72	19200	2.48	8.70	
	EHD4X48A**	†	TDR & TXV	44500	0.73	11.00	33000	0.77	13.50	48000	3.48	35400	3.50	29800	2.60	20000	2.34	8.30	
	EHD4X60A**	*8MPV100	TDR & TXV	46500	0.73	11.60	34200	0.77	15.00	49500	3.66	35000	3.78	29600	2.70	19500	2.48	8.80	
	EHD4X60A**	*8MPV125	TDR & TXV	46500	0.73	11.70	34000	0.77	15.00	49500	3.68	34800	3.78	29600	2.72	19400	2.48	8.80	
	EHD4X60A**	*9MPV100	TDR & TXV	46000	0.73	11.40	34000	0.77	14.50	49500	3.60	35000	3.74	29800	2.66	19600	2.46	8.70	
	EHD4X60A**	*9MPV125	TDR & TXV	46000	0.73	11.50	34000	0.77	15.00	49500	3.62	35000	3.76	29600	2.68	19500	2.48	8.80	
	EHD4X60A**	*9MVX080	TDR & TXV	46000	0.73	11.40	34200	0.77	15.00	49000	3.62	35200	3.78	29800	2.68	19600	2.48	8.70	
	EHD4X60A**	*9MVX100	TDR & TXV	46000	0.73	11.50	34000	0.77	15.00	49000	3.60	34800	3.74	29600	2.68	19500	2.46	8.70	
	EHD4X60A**	MV16J22**B*	TDR & TXV	46000	0.73	12.10	34000	0.77	15.50	49000	3.68	34600	3.80	29000	2.76	19200	2.50	8.80	
	EHD4X60A**	MV20L24**B*	TDR & TXV	46000	0.73	12.20	34000	0.77	15.50	49000	3.70	34600	3.80	29000	2.76	19200	2.50	8.80	
	EHD4X60A**	†	TDR & TXV	45500	0.73	11.20	33200	0.77	13.50	48000	3.50	35400	3.52	29800	2.62	20000	2.34	8.30	
	FVM4X48****	†	TDR & TXV	45500	0.73	11.90	33800	0.77	15.00	48000	3.58	34600	3.74	29000	2.70	19200	2.48	8.70	
T4H560GKD	‡FVM4X60****	†	TDR & TXV	57000	0.72	11.60	42000	0.77	15.00	59000	3.62	43000	3.74	36200	2.72	25800	2.54	8.50	
	ED*4X60J**	*8MPV100	TDR & TXV	56500	0.72	10.80	41500	0.77	14.00	59500	3.44	43500	3.62	37200	2.60	26200	2.48	8.50	
	ED*4X60J**	*8MPV125	TDR & TXV	56500	0.72	11.10	41500	0.77	14.50	59000	3.48	43000	3.62	36800	2.62	26000	2.48	8.50	
	ED*4X60J**	*9MPV100	TDR & TXV	56000	0.72	10.60	41500	0.77	14.00	59500	3.40	43500	3.58	37200	2.56	26400	2.44	8.40	
	ED*4X60J**	*9MVX080	TDR & TXV	56500	0.72	10.60	41500	0.77	14.00	59500	3.40	43500	3.58	37400	2.58	26400	2.44	8.40	
	ED*4X60J**	MV16J22**B*	TDR & TXV	57000	0.72	11.50	41500	0.77	15.00	58500	3.54	42500	3.68	36200	2.70	25800	2.52	8.50	
	ED*4X60J**	†	TDR & TXV	56000	0.72	11.00	40500	0.77	13.00	59000	3.44	43500	3.46	36800	2.60	26600	2.38	8.20	
	ED*4X60L**	*9MPV125	TDR & TXV	56000	0.72	10.70	41000	0.77	14.00	59500	3.40	43000	3.58	37200	2.58	26200	2.44	8.40	
	ED*4X60L**	*9MVX100	TDR & TXV	56000	0.72	10.80	41000	0.77	14.00	59500	3.42	43000	3.58	37000	2.58	26200	2.46	8.40	
	ED*4X60L**	MV20L24**B*	TDR & TXV	56500	0.72	11.50	41500	0.77	15.00	58500	3.54	42500	3.68	36200	2.68	25800	2.52	8.50	
	ED*4X60L**	†	TDR & TXV	56000	0.72	11.00	40500	0.77	13.00	59000	3.44	43500	3.46	36800	2.60	26600	2.38	8.20	
	EHD4X60A**	*8MPV100	TDR & TXV	56500	0.72	10.90	41500	0.77	14.00	60000	3.50	43500	3.66	37200	2.62	26200	2.48	8.60	
	EHD4X60A**	*8MPV125	TDR & TXV	56500	0.72	11.10	41500	0.77	14.50	60000	3.54	43000	3.64	36800	2.64	26000	2.48	8.60	
	EHD4X60A**	*9MPV100	TDR & TXV	56500	0.72	10.70	41500	0.77	14.00	60500	3.46	43500	3.60	37400	2.58	26400	2.46	8.40	

2008 ENERGY STAR compliance for combinations with all three: SEER 14.0 or higher and EER 11.5 or higher and HSPF 8.2 or higher.

† For coils not listed with a matching furnace or blower, coil rating applies with any indoor blower device.

– continued on next page –

COOLING & HEATING PERFORMANCE FOR COMBINATION RATINGS (continued)
Indoor Models

Outdoor Model	Current Indoor Model (‡ tested combo)	Furnace Model	Factory Installed (Field Installed)	Cool 95° F (35° C)						Heat 47° F (8.3° C)				Heat 17° F (-8.3° C)				HSPF	
				High Stage			Low Stage			SEER	High Stage		Low Stage		High Stage		Low Stage		
				BTU/hr	S / T	EER	BTU/hr	S / T	BTU/hr		COP	BTU/hr	COP	BTU/hr	COP	BTU/hr	COP		
T4H560GKD (continued)	EHD4X60A**	*9MPV125	TDR & TXV	56500	0.72	10.80	41500	0.77	14.00	60000	3.48	43500	3.62	37200	2.60	26200	2.46	8.50	
	EHD4X60A**	*9MVX080	TDR & TXV	56500	0.72	10.70	41500	0.77	14.00	60500	3.46	43500	3.62	37400	2.60	26400	2.46	8.40	
	EHD4X60A**	*9MVX100	TDR & TXV	56500	0.72	10.80	41500	0.77	14.00	60000	3.48	43500	3.62	37000	2.60	26200	2.46	8.40	
	EHD4X60A**	MV16J22**B*	TDR & TXV	57000	0.72	11.60	41500	0.77	15.00	59500	3.62	43000	3.70	36200	2.72	25800	2.52	8.50	
	EHD4X60A**	MV20L24**B*	TDR & TXV	57000	0.72	11.60	41500	0.77	15.00	59500	3.62	43000	3.72	36200	2.72	25800	2.52	8.50	
	EHD4X60A**	†	TDR & TXV	56500	0.72	11.00	41000	0.77	13.00	60000	3.50	43500	3.48	36800	2.62	26600	2.38	8.30	

2008 ENERGY STAR compliance for combinations with all three: SEER 14.0 or higher and EER 11.5 or higher and HSPF 8.2 or higher.

† For coils not listed with a matching furnace or blower, coil rating applies with any indoor blower device.

OUTDOOR UNIT MODEL NUMBER IDENTIFICATION GUIDE (single phase)											
Digit Position:	1	2	3	4	5, 6	7	8	9	10	11	12
Example Part Number:	T	4	H	5	24	G	K	D	1	0	0
T = Tempstar Mainline											
2 = R-22											
4 = R-410A											
REFRIGERANT											
A = Air Conditioner											
H = Heat Pump											
TYPE											
3 = 13 SEER											
4 = 14 SEER											
5 = 15 SEER											
6 = 16 SEER											
7 = 17 SEER											
8 = 18 SEER											
NOMINAL EFFICIENCY											
24 = 24,000 BTUH = 2 tons											
36 = 36,000 BTUH = 3 tons											
48 = 48,000 BTUH = 4 tons											
60 = 60,000 BTUH = 5 tons											
NOMINAL CAPACITY											
A = Standard Grille											
G = Coil Guard Grille											
C = Coastal											
FEATURES											
K = 208/230-1-60											
VOLTAGE											
Sales Code											
Engineering Revision											
Extra Digit											
Extra Digit											

ACCESSORIES PART NUMBER IDENTIFICATION GUIDE									
Digit Position:	1	2	3	4	5	6, 7	8, 9	10, 11	
Example Part Number:	N	A	S	A	0	01	01	CH	
N = Non-Branded									
BRANDING									
A = Accessory									
PRODUCT GROUP									
S = Split System (AC & HP)									
KIT USAGE									
A = Original									
B = 2nd Generation									
0 = Generic or Not Applicable									
2 = R-22									
4 = R-410A									
REFRIGERANT									
Product Identifier Number									
Package Quantity									
Type of Kit (Example: CH = Crankcase Heater)									