

PACKAGE GAS HEATING/ELECTRIC COOLING, R-410A SINGLE PACKAGE ROOFTOP 3 – 15 TONS (1 & 3-Phase)

BUILT TO LAST, EASY TO INSTALL AND SERVICE

- High efficiency gas heating and electric cooling with a low profile, prewired, tested, and charged at the factory
- Field Convertible from vertical to horizontal airflow on all models. No special kit required on 036-150 models. Field accessory supply duct kit required for 180 size model only.
- Full perimeter base rail with built-in rigging adapters and fork truck slots
- Pre-painted exterior panels and primer-coated interior panels tested to 500 hours salt spray protection
- Fully insulated cabinet
- Tubular-section type aluminized heat exchanger standard with optional stainless steel exchanger available
- Single-stage or two stage cooling capacity control
- Redundant gas valve, up to two stages of heating
- Exclusive IGC solid-state control for on-board diagnostics with LED error code designation, burner control logic and energy saving indoor fan motor delay
- High efficiency, gas heat with induced draft flue exhaust design
- Scroll compressors with internal line-break overload protection
- All units have high and low pressure switches
- Two inch disposable fiberglass type return air filters in dedicated rack with tool-less filter access door
- Refrigerant circuits contain a liquid line filter drier to trap dirt and moisture
- Indoor and outdoor coils constructed of aluminum fins mechanically bonded to seamless copper tubes
- Newly-designed indoor refrigerant header for easier maintenance and replacement
- Exclusive non-corrosive composite condensate pan in accordance with ASHRAE 62 Standard, sloping design; side or center drain
- Belt drive evaporator-fan motor and pulley combinations available to meet any application



RGS036-072



RGS091-121



Use of the AHRI Certified TM Mark indicates a manufacturer's participation in the program. For verification of certification for individual products, go to www.ahridirectory.org.



UNIT PERFORMANCE DATA - Single Stage Cooling

UNIT	Nominal Tons	COOLING			GAS HEATING		Unit Dimensions H x W x L	Unit Weight lb. [kg]
		Net Cap. (Btuh)	SEER	EER	Input Cap. (Btuh)	AFUE %		
RGS036 [^] AA0AAA	3	34,600	13.0	11.0	72,000-115,000	78-79.0	33-3/8" x 46-3/4" x 74-3/8"	483 [219]
RGS048 [^] AA0AAA	4	45,000	13.0	11.0	72,000-150,000	78-79.0	33-3/8" x 46-3/4" x 74-3/8"	537 [244]
RGS060 [^] AA0AAA	5	59,000	13.0	10.8	72,000-150,000	78-79.0	33-3/8" x 46-3/4" x 74-3/8"	569 [258]
RGS072 [^] AA0AAA	6	70,000	N/A	11.0	72,000-150,000	80-81.0	41-3/8" x 46-3/4" x 74-3/8"	652 [296]
RGS091 [^] AA0AAA	7-1/2	88,000	N/A	11.0	125,000-224,000	80-81.0	41-1/4" x 59-1/2" x 88-1/8"	810 [367]
RGS101 [^] AA0AAA	8-1/2	97,000	N/A	11.0	125,000-224,000	80-81.0	49-3/8" x 59-1/2" x 88-1/8"	910 [413]
RGS121 [^] AA0AAA	10	117,000	N/A	11.0	180,000-250,000	80-81.0	49-3/8" x 59-1/2" x 88-1/8"	965 [438]

UNIT PERFORMANCE DATA - Dual Stage Cooling

UNIT	Nominal Tons	COOLING			GAS HEATING		Unit Dimensions H x W x L	Unit Weight lb. [kg]
		Net Cap. (Btuh)	SEER	EER	Input Cap. (Btuh)	AFUE %		
RGS090 [^] AA0AAA	7-1/2	83,000	N/A	11.0	125,000-224,000	80-81.0	41-1/4" x 59-1/2" x 88-1/8"	810 [367]
RGS102 [^] AA0AAA	8-1/2	99,000	N/A	11.0	125,000-224,000	80-81.0	49-3/8" x 59-1/2" x 88-1/8"	910 [413]
RGS120 [^] AA0AAA	10	114,000	N/A	11.1	180,000-250,000	80-81.0	49-3/8" x 59-1/2" x 88-1/8"	965 [438]
RGS150 [^] AA0AAA	12-1/2	140,000	N/A	10.8	180,000-250,000	80-81.0	49-3/8" x 59-1/2" x 88-1/8"	1116 [506]
RGS180 [^] AA0AAA	15	174,000	N/A	10.8	180,000-350,000	80-81.0	57-3/8" x 63-3/8" x 115-7/8"	1380 [627]

* Indicates Unit voltage: K = 208/230-1-60, H = 208/230-3-60, L = 460-3-60, S = 575-3-60

NOTE: BASE MODEL NUMBERS LISTED. SEE MODEL NOMENCLATURE LISTING FOR ADDITIONAL OPTIONS

UNIT PERFORMANCE DATA – Single Stage Cooling Low Nox Models								
UNIT	Nominal Tons	COOLING			GAS HEATING		Unit Dimensions H x W x L	Unit Weight lb. [kg]
		Net Cap. (Btuh)	SEER	EER	Input Cap. (Btuh)	AFUE %		
RGS036* ^{AA0AAA}	3	34,600	13.0	11.0	72,000-115,000	80.6	33-3/8" x 46-3/4" x 74-3/8"	483 [219]
RGS048* ^{AA0AAA}	4	45,000	13.0	11.0	72,000-150,000	80-82.0	33-3/8" x 46-3/4" x 74-3/8"	537 [244]
RGS060* ^{AA0AAA}	5	59,000	13.0	10.8	72,000-150,000	80-82.0	33-3/8" x 46-3/4" x 74-3/8"	569 [258]

FEATURES AND BENEFITS CONTINUED

- Access panels with easy grip handles provide quick and easy access to the blower and blower motor, control box, and compressor.
- “No-strip” screw system has superior holding power and guides screws into position while preventing the screw from stripping the unit’s metal.
- Newly designed terminal board facilitates simple safety circuit troubleshooting and simplified control box arrangement
- Outdoor temperature cooling operation range up to 115°F (46°C) and down to 25°F (-4°C) using winter start kit
- Fixed orifice metering devices on all models to precisely control refrigerant flow
- Large, laminated control wiring and power wiring drawings are affixed to unit to make troubleshooting easy
- Capable of thru-the-base or thru-the-curb gas line routing
- Single point gas and electrical connections
- “Low NOx” models include stainless steel heat exchangers

WARRANTY

- 15 Year limited warranty on stainless steel heat exchanger
- 10 Year limited warranty on aluminized heat exchanger
- 5 Year limited warranty on compressor
- 1 Year limited warranty on parts

TABLE OF CONTENTS

	PAGE
MODEL NUMBER NOMENCLATURE	3
FACTORY OPTIONS AND/OR ACCESSORIES	4
AHRI COOLING RATING TABLE	10
HEAT RATING TABLES	11
SOUND PERFORMANCE TABLE	12
PHYSICAL DATA	14
CURBS & WEIGHTS DIMENSIONS	20
APPLICATION DATA	32
COOLING TABLES	34
OUTDOOR AIR INTAKE & EXHAUST PERF	46
FAN PERFORMANCE	48
ELECTRICAL INFO	61
MCA / MOCF	65
TYPICAL WIRING DIAGRAMS	68
SEQUENCE OF OPERATION	72
APPENDIX A – ALTITUDE COMPENSATION TABLES	72
GUIDE SPECIFICATIONS	75

MODEL NOMENCLATURE

MODEL SERIES	R	G	S	0	9	1	H	D	A	A	0	A	A	A
Position Number	1	2	3	4	5	6	7	8	9	10	11	12	13	14
R = Rooftop														
A = Air Conditioning (Cooling Only)														
H = Heat Pump														
G = Gas/Electric														
Type														
S = Standard ASHRAE 90.1-2010 Efficiency														
Efficiency														
036 = 36,000 = 3 Tons														
048 = 48,000 = 4 Tons														
060 = 60,000 = 5 Tons														
072 = 72,000 = 6 Tons														
091 = 90,000 = 7.5 Tons (Single Compressor)														
090 = 90,000 = 7.5 Tons (Dual Compressor)														
101 = 102,000 = 8.5 Tons (Single Compressor)														
102 = 102,000 = 8.5 Tons (Dual Compressor)														
121 = 102,000 = 10 Tons (Single Compressor)														
120 = 120,000 = 10 Tons (Dual Compressor)														
150 = 150,000 = 12.5 Tons (Dual Compressor)														
180 = 180,000 = 15 Tons (Dual Compressor)														
Nominal Cooling Capacity														
K = 208/230-1-60														
H = 208/230-3-60														
L = 460-3-60														
S = 575-3-60														
Voltage														
D = Low Heat														
E = Medium Heat														
F = High Heat														
L = Low Heat, Low NOx														
M = Medium Heat, Low NOx														
N = High Heat, Low NOx														
S = Low Heat, Stainless Steel Heat Exchanger														
R = Medium Heat, Stainless Steel Heat Exchanger														
T = High Heat, Stainless Steel Heat Exchanger														
Heating Capacity (See spec sheet for actual capacity)														
A = Standard Motor (3 - 15 Ton)														
C = Medium Static Motor (5 - 15 Ton)														
B = High Static Motor (3-12.5 ton 3 phase models only)														
E = High Static, High Efficiency Motor (15 ton only)														
Motor Option														
A = None														
B = Economizer w/Bara-relief, OA Temp sensor														
E = Economizer w/Bara-relief + CO2 Sensor, OA Temp sensor														
H = Economizer w/Bara-relief, enthalpy sensor														
L = Economizer w/Bara-relief + CO2 Sensor, enthalpy sensor														
P = 2-Position damper														
Outdoor Air Options / Control (See spec sheet for details)														
0A = No Options														
4B = Non-Fused Disconnect														
AT = Non-powered 115v C.O.														
BR = Supply Air Smoke Detector														
BA = Non-powered 115v C.O. + SA Smoke Detector														
7C = Non-Fused Disconnect + Non-Powered 115v C.O.														
7K = Non-Fused Disconnect + Non-Powered 115v C.O.+ SA Smoke detector														
8A = Non-Fused Disconnect + SA Smoke detector														
Factory Installed Options														
A = Aluminum / Copper Cond & Evap Coil														
B = Precoat Alum/Copper Cond with Alum / Copper Evap (3 phase only)														
C = E-Coated Alum/Copper Cond with Alum / Copper Evap (3 phase only)														
D = E-Coated Alum / Copper Cond & Evap (3 phase only)														
E = Copper/Copper Cond & Alum/Copper Evap (3 phase only)														
F = Copper/Copper Cond & Evap (3 phase only)														
Condenser / Evaporator Coil Configuration														
A = Original Design														

Sales Digit

NOTE: Factory installed options are NOT available on single phase models.

Table 1 – FACTORY INSTALLED OPTIONS AND FIELD INSTALLED ACCESSORIES

CATEGORY	ITEM	FACTORY INSTALLED OPTION	FIELD INSTALLED ACCESSORY
Cabinet	Thru-the-base electrical or gas-line connections		X
	Supply Duct Cover (15 ton only)		X
Coil Options	Copper/Copper indoor and/or outdoor coils	X	
	Pre-coated outdoor coils	X	
	Premium, E-coated outdoor coils	X	
Condenser Protection	Condenser coil hail guard (louvered design)		X
Controls	Smoke detector (supply air)	X	
	Time Guard II compressor delay control circuit		X
	Phase Monitor		X
Economizers & Outdoor Air Dampers	Economizer (for electro-mechanical controlled RTUs)	X	X
	Motorized 2 position outdoor-air damper	X	X
	Manual outdoor-air damper		X
	Barometric relief ¹	X	X
	Power exhaust		X
Economizer Sensors & IAQ Devices	Single dry bulb temperature sensors ²	X	X
	Single enthalpy sensors ²	X	X
	Differential enthalpy sensors ²		X
	CO ₂ sensor (wall, duct, or unit mounted) ²		X
Gas Heat	Liquid propane (LP) conversion kit		X
	High altitude conversion kit		X
	Flue Shield		X
	Flue Discharge Deflector		X
	Stainless Steel Heat Exchanger	X	
Indoor Motor & Drive	Multiple motor and drive packages	X	
Low Ambient Control	Winter start kit ³		X
	Head pressure controller ³		X
Power Options	Convenience outlet (unpowered)	X	
	Non-fused disconnect	X	
Roof Curbs	Roof curb 14" (356mm)		X
	Roof curb 24" (610mm)		X

NOTES:

1. Included with economizer.
2. Sensors used to optimize economizer performance.
3. See application data for assistance.
4. Factory Installed Options are NOT available on single phase models.

FACTORY OPTIONS AND/OR ACCESSORIES

Economizer (dry–bulb or enthalpy)

Economizers save money. They bring in fresh, outside air for ventilation; and provide cool, outside air to cool your building. This is the preferred method of low–ambient cooling. When coupled to CO₂ sensors, Economizers can provide even more savings by coupling the ventilation air to only that amount required based on occupancy.

Economizers are available, installed and tested by the factory, (3 phase only), with either enthalpy or dry–bulb temperature inputs. There are also models for electromechanical as well as direct digital controllers. Additional sensors are available as accessories to optimize the economizers.

CO₂ Sensor

Improves productivity and saves money by working with the economizer to intake only the correct amount of outside air for ventilation. As occupants fill your building, the CO₂ sensor detects their presence through increasing CO₂ levels, and opens the economizer appropriately.

When the occupants leave, the CO₂ levels decrease, and the sensor appropriately closes the economizer. This intelligent control of the ventilation air, called Demand Control Ventilation (DCV) reduces the overall load on the rooftop, saving money. CO₂ sensors are available with the economizer, installed and tested by the factory.

Smoke Detectors

Smoke detectors immediately shut down the rooftop unit when smoke is detected. Supply air smoke detectors are available, installed by the factory.

Louvered Hail Guards

Sleek, accessory louvered panels protect the condenser coil from hail damage, foreign objects, and incidental contact.

Convenience Outlet (un–powered)

Lower service bills by including a convenience outlet in your specification. Provides a convenient, 15 amp, 115v GFCI receptacle.

Non–fused Disconnect

This OSHA–compliant, factory–installed, safety switch allows a service technician to locally secure power to the rooftop.

Barometric Relief

Gravity controlled, barometric relief equalizes building pressure and ambient air pressures. This can be a cost effective solution to prevent building pressurization.

Power Exhaust

Superior internal building pressure control. This field–installed accessory may eliminate the need for costly, external pressure control fans.

Time Guard II Control Circuit

This accessory protects your compressor by preventing short–cycling in the event of some other failure, prevents the compressor from restarting for 30 seconds after stopping. Not required with authorized commercial thermostats.

Motorized 2–Position Damper

A 2–position, motorized outdoor air damper is available factory installed and admits up to 100% outside air. Using reliable, gear–driven technology, the 2–position damper opens to allow ventilation air and closes when the rooftop stops, stopping unwanted infiltration.

Manual OA Damper

Accessory manual outdoor air dampers are an economical way to bring in ventilation air.

Head Pressure Controller

The motor controller is a low ambient, head pressure controller kit that is designed to maintain the unit's condenser head pressure during periods of low ambient cooling operation. This device should be used as an alternative to economizer free cooling not when economizer usage is either not appropriate or desired. The controller will either cycle the outdoor–fan motors or operate them at reduced speed to maintain the unit operation, depending on the model.

Winter Start Kit

The accessory winter start kit extends the low ambient limit of your rooftop to 25°F (–9°C). The kit bypasses the low pressure switch, preventing nuisance tripping of the low pressure switch. Other low ambient precautions may still be prudent.

Liquid Propane Heating

Convert your gas heat rooftop from standard natural gas operation to liquid propane using this field–installed kit.

High Altitude Heating

High altitudes have less oxygen, which means heat exchangers need less fuel. The new gas orifices in this field–installed kit make the necessary adjustment for high altitude applications. They restore the optimal fuel to air mixture and maintain healthy combustion at altitudes above 2000 ft (610m). Kits may not be required in all areas.

Flue Discharge Deflector

The flue discharge deflector is a useful accessory when flue gas recirculation is a concern. By venting the flue discharge upwards, the deflector minimizes the chance for a neighboring unit to intake the flue exhaust.

Stainless Steel Heat Exchanger (Optional)

The stainless steel heat exchanger option provides the tubular heat exchanger be made out of a minimum 20 gage type 409 stainless steel for applications where the mixed air to the heat exchanger is expected to drop below 45°F (7°C). Stainless steel may be specified on applications where the presence of airborne contaminants require its use (applications such as paper mills) or in areas with very high outdoor humidity that may result in severe condensation in the heat exchanger during cooling operation.

Flue Discharge Heat Shield

The flue discharge heat shield keeps people from touching the rooftop unit's potentially hot flue discharge. This is especially useful for ground level applications, where more, untrained people could have access to the unit's exterior.

Alternate Motors and Drives

Some applications need larger horsepower motors, some need more airflow, and some need both. Regardless of the case, your unit has a factory installed combination to meet your application. A wide selection of motors and pulleys (drives) are available, factory installed, to handle nearly any application.

Thru–the–Base Connections

Thru–the–base connections, available as accessory, are necessary to ensure proper connection and seal when routing wire and piping through the rooftop's basepan and curb. These couplings eliminate roof penetration and should be considered for gas lines, main power lines, as well as control power.

Supply Duct Cover

This supply duct cover is required when field converting the factory standard vertical duct supply to horizontal duct supply configuration. One required per unit. (180 size only)

ACCESSORIES – RGS036–180

FLAT ROOF CURBS		
Model Number	Description	Use With Model Size
CRRFCURB001A01	14" High Roof Curb. Ductwork attaches to the roof curb. Includes thru-the-bottom capability.	036 – 072
CRRFCURB003A01		090 – 150
CRRFCURB074A00		180
CRRFCURB002A01	24" High Roof Curb. Ductwork attaches to the roof curb. Includes thru-the-bottom capability.	036 – 072
CRRFCURB004A01		090 – 150
CRRFCURB075A00		180
ECONOMIZERS		
Model Number	Description	Use With Model Size
DNECOMZR020A02	Vertical EconoMi\$er IV with solid-state controller, gear-driven, 3-position modulating damper, spring return actuator, up to 100% barometric relief, supply and outdoor air sensors, and CO2 sensor compatible.	036 – 072
DNECOMZR021A03	Vertical EconoMi\$er IV with solid-state controller, gear-driven, 3-position modulating damper, spring return actuator, up to 100% barometric relief, supply and outdoor air sensors, and CO2 sensor compatible.	090 – 150
DNECOMZR062A00	Vertical EconoMi\$er IV with solid-state controller, gear-driven, 3-position modulating damper, spring return actuator, up to 100% barometric relief, supply and outdoor air sensors, and CO2 sensor compatible.	180
DNECOMZR024A02	Horizontal EconoMi\$er IV with solid-state controller, gear-driven, 3-position modulating damper, spring return actuator, up to 100% barometric relief, supply and outdoor air sensors, and CO2 sensor compatible.	036 – 072
DNECOMZR025A02	Horizontal EconoMi\$er IV with solid-state controller, gear-driven, 3-position modulating damper, spring return actuator, up to 100% barometric relief, supply and outdoor air sensors, and CO2 sensor compatible.	090 – 150
DNECOMZR064A00	Horizontal EconoMi\$er IV with solid-state controller, gear-driven, 3-position modulating damper, spring return actuator, up to 100% barometric relief, supply and outdoor air sensors, and CO2 sensor compatible.	180
POWER EXHAUST		
Model Number	Description	Use With Model Size
DNPWREXH030A01	Vertical Power Exhaust 208/230 volt (1 or 3 Phase)	036 – 072
DNPWREXH021A01	Vertical Power Exhaust 460 volt	036 – 072
DNPWREXH022A01	Vertical Power Exhaust 208/230 volt (1 or 3 Phase)	090 – 150
DNPWREXH023A01	Vertical Power Exhaust 460 volt	090 – 150
DNPWREXH080A00	Vertical Power Exhaust 208/230 volt	180
DNPWREXH081A00	Vertical Power Exhaust 460 volt	180
DNPWREXH028A01	Horizontal Power Exhaust 208/230 & 575 volt (1 or 3 Phase)	036 – 150
DNPWREXH029A01	Horizontal Power Exhaust 460 volt	036 – 150
DNPWREXH082A00	Horizontal Power Exhaust 208/230 & 575 volt	180
DNPWREXH083A00	Horizontal Power Exhaust 460 volt	180
575V TRANSFORMER		
Model Number	Description	Use With Model Size
1171494 ²	Transformer for conversion from 575v to 208/230v power exhaust applications.	ALL

ACCESSORIES – RGS036–180

MANUAL OUTDOOR AIR DAMPERS		
Model Number	Description	Use With Model Size
CRMANDPR001A03	25% Open Manual Fresh Air Damper	036 – 072
CRMANDPR001A02	50% Open Manual Fresh Air Damper	036 – 072
CRMANDPR002A03	25% Open Manual Fresh Air Damper	090 – 150
CRMANDPR002A02	50% Open Manual Fresh Air Damper	090 – 150
CRMANDPR011A00	50% Open Manual Fresh Air Damper	180
MOTORIZED OUTDOOR AIR DAMPERS		
Model Number	Description	Use With Model Size
CRTWOPOS010A00	Motorized 2 position outdoor air damper (25–100% Outdoor Air)	036 – 072
CRTWOPOS011A00	Motorized 2 position outdoor air damper	090 – 150
CRTWOPOS014A00	Motorized 2 position outdoor air damper (25–100% Outdoor Air)	180
ECONOMIZER SENSORS		
Model Number	Description	Use With Model Size
DNTEMPSN002A00	Outdoor or Return Dry Bulb Temperature Sensor used with Electro–Mechanical control.	ALL Economizers
DNCBDIOX005A00	CO ₂ Sensor for use in return airstream. Also includes Aspirator Box required for Duct Mounting.	ALL Economizers
DNENTDIF004A00	Return Air Enthalpy Sensor used with Electro–Mechanical controls, use with AXB078ENT for differential enthalpy control.	ALL Economizers
AXB078ENT	Accusensor II Economizer Differential Enthalpy Control Upgrade	ALL Economizers
SPECIAL – 180 SIZE SPECIFIC ASSESSORIES		
Model Number	Description	Use With Model Size
CRDISBKT001A00	Disconnect Switch Bracket – Provides a pre engineered and sized mounting bracket for applications requiring a unit mounted fused disconnect of greater than 100 amps. Bracket assures that no damage will occur to coils when mounting with screws and other fasteners.	180
CRDUCTCV002A00	Supply Duct Cover – This supply duct cover is required when field converting the factory standard vertical duct supply to horizontal duct supply configuration. One required per unit.	180
THROUGH-THE-BOTTOM/CURB POWER CONNECTION		
Model Number	Description	Use With Model Size
CRBTMPWR001A01	Thru–the–bottom electrical connections and thru–the–curb gas connections. Includes a 3/4–inch diameter liquid tight conduit fitting for high voltage power wires	036 – 072
CRBTMPWR002A01	Thru–the–bottom electrical connections and thru–the–curb gas connections. Includes a 1–1/4–inch diameter liquid tight conduit fitting for high voltage power wires	090 – 150
CRBTMPWR003A01	Thru–the–bottom power, control, and gas connections. Includes a 3/4–inch diameter liquid tight conduit fitting for high voltage power wires	036 – 072
CRBTMPWR004A01	Thru–the–bottom power, control, and gas connections. Includes a 1–1/4–inch diameter liquid tight conduit fitting for high voltage power wires	090 – 150
CRBTMPWR005A00	Thru–the–bottom power, control, and gas connections. Includes a 1–1/4 inch diameter liquid tight conduit fitting for high voltage power wires	180
CRBTMPWR006A00	Thru–the–bottom power, control, and gas connections. Includes a 1–1/2 inch diameter liquid tight conduit fitting for high voltage power wires	
CRBTMPWR007A00	Thru–the–bottom power, control, and gas connections. Includes a 2 inch diameter liquid tight conduit fitting for high voltage power wires	

ACCESSORIES – RGS036–180

LOW AMBIENT CONTROLS *		
Model Number	Description	Use With Model Size
32LT900301 ¹	Motormaster I Solid–State Variable Speed Motor Controller enables cooling down to –20° F by varying the speed on the condenser fan.	036 – 121 208/230–1–60, 208/203–3–60, 575–3–60
32LT900611 ¹	MotorMaster I Solid–State Variable Speed Motor Controller enables cooling down to –20° F by varying the speed on the condenser fan.	036 – 121 460–3–60
CPLOWAMB001A00	Motormaster® II Low Ambient Control – Enables cooling system to operate down to 0° F by cycling condenser fan on and off. The control is activated by a temperature sensor. No motor change–out required.	036 – 121 208/230–3–60, 460–3–60 ⁴
1171974 ²	Motormaster I Compatible Condenser Fan Motor	036 – 121 208/230–1–60, 208/230–3–60, 575–3–60
1171975 ²	Motormaster I Compatible Condenser Fan Motor	036 – 121 460–3–60
CRLOWAMB030A00 ³	Motormaster V Low Ambient Kit. Mechanical cooling operation down to –20° F (– 29° C)	150 208/230–3–60
CRLOWAMB031A00 ³	Motormaster V Low Ambient Kit. Mechanical cooling operation down to –20° F (– 29° C)	150 460–3–60
CRLOWAMB032A00 ³	Motormaster V Low Ambient Kit. Mechanical cooling operation down to –20° F (– 29° C).	150 575–3–60
CRLOWAMB039A00	Motormaster I Low Ambient Kit. Mechanical cooling operation down to –20° F (– 29° C). Kit includes 3 motors, MotorMaster controller, wiring label, and required wire ties and connectors, DNWINSTR001A00 also required (one per refrigerant circuit)	180 208/230–3–60
CRLOWAMB040A00	Motormaster I Low Ambient Kit. Mechanical cooling operation down to –20° F (– 29° C). Kit includes 3 motors, MotorMaster controller, wiring label, and required wire ties and connectors) **	180 460–3–60 575–3–60
CRTRXKIT001A00	Motormaster I Low Ambient Control – Transformer Kit. Must be used in conjunction with Low Ambient Controller if used on 575–3–60 volt models.	180 575–3–60

*See usage tables in kit instructions.

**DNWINSTR001A00 also required (one per refrigerant circuit.)

¹ Requires motor change out. Sizes 036–072 require one (1) Low Ambient Controller and one (1) compatible condenser fan motor for change–out. Sizes 090–121 require one (1) Low Ambient Controller and two (2) compatible condenser fan motors for change–out.

See Motormaster I kit instructions for capacitor replacement information.

² Available from FAST Parts.

³ No motor change is required on these specific models.

⁴ One DNWINSTR001A00 also required per refrigerant circuit.

ACCESSORIES – RGS036–180 (cont.)

LP GAS CONVERSION KITS*		
Model Number	Description	Use With Model Size
CRLPELEV001A00	LP and Hi Altitude conversion kit. Contains spuds sizes 31, 32, 33, 35, and 36.	036 – 150
CRLPELEV002A00	LP and Hi Altitude conversion kit. Contains spuds sizes 37, 38, 39, 44, and 45.	036 – 150
CRLPELEV003A00	LP and Hi Altitude conversion kit. Contains spuds sizes 46, 47, 48, 49, and 50.	036 – 150
CRLPELEV004A00	LP and Hi Altitude conversion kit. Contains spuds sizes 51, 52, 53, 54, and 55.	036 – 150
CRLPELEV007A00	LP and Hi Altitude conversion kit. Contains spuds sizes 36, 37, 38, and 39.	180
CRLPELEV008A00	LP and Hi Altitude conversion kit. Contains spuds sizes 40, 41, 42, and 43.	180
CRLPELEV009A00	LP and Hi Altitude conversion kit. Contains spuds sizes 51, 52, 53, 54, and 55.	180
* See Annex A, LP kit instructions, and service manual for more details.		
HEATING UPGRADE KITS		
Model Number	Description	Use With Model Size
CRFLUEDS001A00	Flue Discharge Deflector	036 – 180
CRFLUEHD001A01	Flue Exhaust Heat Shield	036 – 180
CONTROL UPGRADE KITS		
Model Number	Description	Use With Model Size
NRTIMEGD001A00	Time Guard II	036 – 180
CRSDTEST001A00	Remote keyed attenuator / test / reset station	036 – 180
DNWINSTR001A00	Electronic phase monitor breaks "R" control signal if trouble is detected. (Allows operation down to 25°F from standard 40°F.)	036 – 180
CRPHASE3001A02	Phase Monitor Control	036 – 180 (3 Phase only)
CRPHASE3002A00	Phase Monitor Control	036 – 180 (575v only)
HAIL GUARDS		
Model Number	Description	Use With Model Size
CRLVHLGD011A00	Louvered Condenser Coil Hail Guard	036
CRLVHLGD012A00	Louvered Condenser Coil Hail Guard	048 – 060
CRLVHLGD013A00	Louvered Condenser Coil Hail Guard	072
CRLVHLGD014A00	Louvered Condenser Coil Hail Guard	090, 091
CRLVHLGD015A00	Louvered Condenser Coil Hail Guard	101
CRLVHLGD016A00	Louvered Condenser Coil Hail Guard	102, 120, 121, 150
CRLVHLGD032A00	Louvered Condenser Coil Hail Guard	180

² Available from FAST Parts.

Table 2 – AHRI COOLING RATING TABLE – Single Stage Cooling

UNIT RGS	COOLING STAGES	NOM. CAPACITY (TONS)	NET COOLING CAPACITY (MBH)	TOTAL POWER (KW)	SEER	EER	IEER
036	1	3	34.6	3.1	13.0	11.0	–
048	1	4	45.0	4.0	13.0	11.0	–
060	1	5	59.0	5.5	13.0	10.8	–
072	1	6	70.0	6.4	–	11.0	11.2
091	1	7.5	88.0	8.0	–	11.0	11.2
101	1	8.5	97.0	8.8	–	11.0	11.2
121	1	10	117.0	10.6	–	11.0	11.2

Table 3 – AHRI COOLING RATING TABLE – Two Stage Cooling

UNIT RGS	COOLING STAGES	NOM. CAPACITY (TONS)	NET COOLING CAPACITY (MBH)	TOTAL POWER (kW)	SEER	EER	IEER
090	2	7.5	83.0	7.5	N/A	11.00	11.7
102	2	8.5	99.0	9.0	N/A	11.00	11.7
120	2	10	114.0	10.3	N/A	11.10	11.8
150	2	12.5	140.0	12.9	N/A	10.80	11.0
180	2	15	174.0	16.1	N/A	10.80	11.7

LEGEND

- AHRI – Air-Conditioning, Heating & Refrigeration Institute
- ASHRAE – American Society of Heating, Refrigerating and Air Conditioning, Inc.
- EER – Energy Efficiency Ratio
- IEER – Integrated Energy Efficiency Ratio
- SEER – Seasonal Energy Efficiency Ratio
- IPLV – Integrated Part Load Value

NOTES:

1. Rated and certified under AHRI Standard 210/240-06 or 340/360-04, as appropriate.
2. Ratings are based on:
Cooling Standard: 80°F (27°C) db, 67°F (19°C) wb indoor air temp and 95°F (35°C) db outdoor air temp.
IPLV Standard: 80°F (27°C) db, 67°F (19°C) wb indoor air temp and 80°F (27°C) db outdoor air temp.
IEER Standard: Procedure described in AHRI Standard 340/360.
3. All RGS units comply with ASHRAE 90.1 2001, 2004 Energy Standard for minimum SEER and EER requirements.
4. RGS units comply with US Energy Policy Act (2005). To evaluate code compliance requirements, refer to state and local codes or visit the following website: <http://bcap-energy.org>.



Use of the AHRI Certified TM Mark indicates a manufacturer's participation in the program. For verification of certification for individual products, go to www.ahridirectory.org.

Table 4 – HEATING RATING TABLE – NATURAL GAS & LIQUID PROPANE

UNIT RGS	GAS HEAT	AL & SS HEAT EXCHANGER		TEMP RISE (DEG F)	THERMAL EFFICIENCY (%)	AFUE (%)	
		INPUT / OUTPUT STAGE 1 (MBH)	INPUT / OUTPUT STAGE 2 (MBH)				
Single Phase	036	LOW	-	72 / 56	25 – 55	82%	79.1%
		MED	-	115 / 89	55 – 85	80%	78.5%
		HIGH	-	-	-	-	-
	048	LOW	-	72 / 56	25 – 55	82%	79.1%
		MED	-	115 / 90	35 – 65	81%	79.0%
		HIGH	-	150 / 117	50 – 80	80%	78.8%
	060	LOW	-	72 / 56	25 – 55	82%	79.1%
		MED	-	115 / 90	35 – 65	81%	79.0%
		HIGH	-	150 / 117	50 – 80	80%	78.8%
Three Phase	036	LOW	-	72 / 59	25 – 55	82%	81.0%
		MED	82 / 66	115 / 93	55 – 85	80%	80.0%
		HIGH	-	-	-	-	-
	048	LOW	-	72 / 59	25 – 55	82%	81.0%
		MED	-	115 / 93	35 – 65	81%	80.0%
		HIGH	120 / 96	150 / 120	50 – 80	80%	80.0%
	060	LOW	-	72 / 59	25 – 55	82%	81.0%
		MED	-	115 / 93	35 – 65	81%	80.0%
		HIGH	120 / 96	150 / 120	50 – 80	80%	80.0%
	072	LOW	-	72 / 59	25 – 55	82%	81.0%
		MED	-	115 / 93	35 – 65	81%	80.0%
		HIGH	120 / 96	150 / 120	50 – 80	80%	80.0%
	090/091	LOW	-	125 / 103	20 – 50	82%	-
		MED	120 / 98	180 / 148	35 – 65	82%	-
		HIGH	180 / 147	224 / 184	45 – 75	82%	-
	101/102	LOW	-	125 / 103	20 – 50	82%	-
		MED	120 / 98	180 / 148	35 – 65	82%	-
		HIGH	180 / 147	224 / 184	45 – 75	82%	-
	120/121	LOW	120 / 98	180 / 148	35 – 65	82%	-
		MED	180 / 147	224 / 184	45 – 75	82%	-
		HIGH	200 / 160	250 / 205	40 – 70	82%	-
150	LOW	120 / 98	180 / 148	20 – 65	82%	-	
	MED	180 / 147	224 / 184	25 – 65	82%	-	
	HIGH	200 / 160	250 / 205	25 – 70	82%	-	
180	LOW	144 / 118	180 / 146	15 – 55	81%	N/A	
	MED	192 / 156	240 / 195	20 – 60	81%	N/A	
	HIGH	280 / 224	350 / 280	35 – 65	80%	N/A	

NOTE:

- Heat ratings are for natural gas heat exchangers operated at or below 2000 ft. For information on LP or altitudes above 2000 ft (610m), see the Application Data section of this book. Accessory LP/High Altitude kits are also available.
- In the USA the input rating for altitudes above 2000 ft (610m) must be derated by 4% for each 1000 ft (305 m) above sea level. In Canada, the input rating must be derated by 10% for altitudes of 2000 ft (610 m) to 4500 ft (1372 m) above sea level.

Table 5 – HEATING RATING TABLE – LOW NO_x¹

UNIT	GAS HEAT	LOW NO _x HEAT EXCHANGER		TEMP RISE (DEG F)	THERMAL EFFICIENCY (%)	AFUE (%)	
		INPUT / OUTPUT STAGE 1 (MBH)	INPUT / OUTPUT STAGE 2 (MBH)				
Single Phase	036	LOW	–	60.0 / 47.0	20 – 50	81%	80.6%
		MED	–	90.0 / 72.0	30 – 60	81%	80.6%
		HIGH	–	–	–	–	–
	048	LOW	–	60.0 / 47.0	20 – 50	81%	80.6%
		MED	–	90.0 / 72.0	30 – 60	81%	80.6%
		HIGH	–	120.0 / 97.0	40 – 70	81%	81.5%
	060	LOW	–	60.0 / 47.0	20 – 50	81%	80.6%
		MED	–	90.0 / 74.0	30 – 60	80%	80.6%
		HIGH	–	120.0 / 97.0	40 – 70	80%	81.5%
Three Phase	036	LOW	–	60.0 / 50.0	20 – 50	81%	80.0%
		MED	–	90.0 / 74.0	30 – 60	81%	81.0%
		HIGH	–	–	–	–	–
	048	LOW	–	60.0 / 50.0	20 – 50	81%	80.0%
		MED	–	90.0 / 74.0	30 – 60	81%	81.0%
		HIGH	–	120.0 / 101.0	40 – 70	81%	80.0%
	060	LOW	–	60.0 / 50.0	20 – 50	81%	80.0%
		MED	–	90.0 / 74.0	30 – 60	80%	81.0%
		HIGH	–	120.0 / 101.0	40 – 70	80%	81.0%

NOTE:

1. Units meet the Southern California Air Quality Management (SCAQM) Counsel Low-NO_x emissions requirement of 40 nanograms per joule or less.
2. See Appendix A on page 65 for ALTITUDE COMPENSATION TABLES.

Table 6 – SOUND PERFORMANCE TABLE

UNIT	COOLING STAGES	OUTDOOR SOUND (dB)								
		A-WEIGHTED	63	125	250	500	1000	2000	4000	8000
036	1	80	90.6	80.9	80.2	76	74.6	71.3	68.5	63.9
048	1	81	90.9	84.6	79.5	77.9	76.5	71.1	66.9	62.5
060	1	78	84.0	82.2	76.3	74.8	72.5	68.8	65.6	61.8
072	1	78	88.8	81.8	76.9	74.4	73.3	69.8	66.3	62.7
091	1	82	90.1	82.6	81.0	79.4	77.0	73.0	70.4	66.7
090	2	82	85.8	84.3	80.5	78.7	76.4	72.7	68.3	65.1
101	1	83	91.2	86.4	81.9	81.0	78.3	73.9	71.4	67.3
102	2	82	88.6	85.0	81.6	79.5	77.4	74.1	71.0	66.3
121	1	82	88.6	85.0	81.6	79.5	77.4	74.1	71.0	66.3
120	2	82	89.0	83.1	80.5	78.5	75.5	71.6	69.6	69.3
150	2	87	87.0	85.2	84.6	84.9	82.2	78.4	75.3	72.9
180	2	87	87.0	85.2	84.6	84.9	82.2	78.4	75.3	72.9

LEGEND

dB – Decibel



Use of the AHRI Certified TM Mark indicates a manufacturer's participation in the program. For verification of certification for individual products, go to www.ahridirectory.org

NOTES:

1. Outdoor sound data is measure in accordance with AHRI standard 270–95.
2. Measurements are expressed in terms of sound power. Do not compare these values to sound pressure values because sound pressure depends on specific environmental factors which normally do not match individual applications. Sound power values are independent of the environment and therefore more accurate.
3. A-weighted sound ratings filter out very high and very low frequencies, to better approximate the response of “average” human ear. A-weighted measurements are taken in accordance with AHRI standard 270–95.

Table 7 – MINIMUM – MAXIMUM AIRFLOW RATINGS – NATURAL GAS & LIQUID PROPANE

UNIT RGS	HEAT LEVEL	COOLING		AL HX HEATING	
		Minimum	Maximum	Minimum	Maximum
036	LOW	900	1500	990	2190
	MED			1000	1550
	HIGH			–	–
048	LOW	1200	2000	990	2190
	MED			1330	2460
	HIGH			1390	2220
060	LOW	1500	2500	990	2190
	MED			1330	2460
	HIGH			1390	2220
072	LOW	1800	3000	990	2190
	MED			1330	2460
	HIGH			1390	2220
090/091	LOW	2250	3750	1900	4750
	MED			2100	3900
	HIGH			2270	3780
101/102	LOW	2550	4250	1900	4750
	MED			2100	3900
	HIGH			2270	3780
120/121	LOW	3000	5000	2100	3900
	MED			2270	3780
	HIGH			2710	4750
150	LOW	3600	6000	2100	6830
	MED			2620	6800
	HIGH			2650	7410
180	LOW	4500	7500	2450	7500
	MED			3000	6750
	HIGH			3990	7200

Table 8 – PHYSICAL DATA (COOLING) 3 – 6 TONS

		RGS036	RGS048	RGS060	RGS072
Refrigeration System					
# Circuits / # Comp. / Type		1 / 1 / Scroll	1 / 1 / Scroll	1 / 1 / Scroll	1 / 1 / Scroll
Refrig. (R-410A) charge per circuit A/B (lbs-oz)		5-10 / -	8-8 / -	10-11 / -	14-2 / -
Metering Device		Fixed Metering Device			
High-press. Trip / Reset (psig)		630 / 505	630 / 505	630 / 505	630 / 505
Low-press. Trip / Reset (psig)		54 / 117	54 / 117	54 / 117	54 / 117
Evap. Coil					
Material		Cu / Al	Cu / Al	Cu / Al	Cu / Al
Coil type		3/8" RTPF	3/8" RTPF	3/8" RTPF	3/8" RTPF
Rows / FPI		2 / 15	2 / 15	4 / 15	4 / 15
Total Face Area (ft ²)		5.5	5.5	5.5	7.3
Condensate Drain Conn. Size		3/4"	3/4"	3/4"	3/4"
Evap. Fan and Motor					
Standard Static 1 phase	Motor Qty / Drive Type	1 / Belt	1 / Belt	1 / Belt	-
	Max BHP	1.2	1.2	1.2	-
	RPM Range	560-854	560-854	770-1175	-
	Motor Frame Size	48	48	48	-
	Fan Qty / Type	1 / Centrifugal	1 / Centrifugal	1 / Centrifugal	-
	Fan Diameter (in)	10 x 10	10 x 10	10 x 10	-
Medium Static 1 phase	Motor Qty / Drive Type	1 / Belt	1 / Belt	1 / Belt	-
	Max BHP	1.2	1.2	1.5	-
	RPM Range	770-1175	770-1175	1035-1466	-
	Motor Frame Size	48	48	56	-
	Fan Qty / Type	1 / Centrifugal	1 / Centrifugal	1 / Centrifugal	-
	Fan Diameter (in)	10 x 10	10 x 10	10 x 10	-
Standard Static 3 phase	Motor Qty / Drive Type	1 / Belt	1 / Belt	1 / Belt	1 / Belt
	Max BHP	1.2	1.2	1.5	2.4
	RPM Range	560-854	560-854	770-1175	1073-1457
	Motor Frame Size	48	48	48	56
	Fan Qty / Type	1 / Centrifugal	1 / Centrifugal	1 / Centrifugal	1 / Centrifugal
	Fan Diameter (in)	10 x 10	10 x 10	10 x 10	10 x 10
Medium Static 3 phase	Motor Qty / Drive Type	1 / Belt	1 / Belt	1 / Belt	1 / Belt
	Max BHP	1.2	1.2	2.4	2.9*
	RPM Range	770-1175	770-1175	1035-1466	1173-1518
	Motor Frame Size	48	48	56	56
	Fan Qty / Type	1 / Centrifugal	1 / Centrifugal	1 / Centrifugal	1 / Centrifugal
	Fan Diameter (in)	10 x 10	10 x 10	10 x 10	10 x 10
High Static 3 phase	Motor Qty / Drive Type	1 / Belt	1 / Belt	1 / Belt	1 / Belt
	Max BHP	2.4	2.4	2.9	3.7
	RPM Range	1035-1466	1035-1466	1303-1687	1474-1788
	Motor Frame Size	56	56	56	56
	Fan Qty / Type	1 / Centrifugal	1 / Centrifugal	1 / Centrifugal	1 / Centrifugal
	Fan Diameter (in)	10 x 10	10 x 10	10 x 10	10 x 10
Cond. Coil					
Material		Cu / Al	Cu / Al	Cu / Al	Cu / Al
Coil type		3/8" RTPF	3/8" RTPF	3/8" RTPF	3/8" RTPF
Rows / FPI		1 / 17	2 / 17	2 / 17	2 / 17
Total Face Area (ft ²)		14.6	16.5	16.5	21.3
Cond. fan / motor					
Qty / Motor Drive Type		1/ Direct	1/ Direct	1/ Direct	1/ Direct
Motor HP / RPM		1/4 / 1100	1/4 / 1100	1/4 / 1100	1/4 / 1100
Fan diameter (in)		22	22	22	22
Filters					
RA Filter # / Size (in)		2 / 16 x 25 x 2	2 / 16 x 25 x 2	2 / 16 x 25 x 2	4 / 16 x 16 x 2
OA inlet screen # / Size (in)		1 / 20 x 24 x 1	1 / 20 x 24 x 1	1 / 20 x 24 x 1	1 / 20 x 24 x 1

* RTPF – Round Tube Plate Fin Coil Design

Table 9 – PHYSICAL DATA (HEATING) 3 – 6 TONS

		RGS036	RGS048	RGS060	RGS072
Gas Connection					
	# of Gas Valves	1	1	1	1
	Nat. gas supply line press (in. w.g.)/(PSIG)	4 –13 / 0.18 – 0.47	4 –13 / 0.18 – 0.47	4 –13 / 0.18 – 0.47	4 –13 / 0.18 – 0.47
	Propane supply line press (in. w.g.)/(PSIG)	11 –13 / 0.40 – 0.47	11 –13 / 0.40 – 0.47	11 –13 / 0.40 – 0.47	11 –13 / 0.40 – 0.47
Heat Anticipator Setting (Amps)					
	1st stage	0.14	0.14	0.14	0.14
	2nd stage	0.14	0.14	0.14	0.14
Natural Gas					
LOW	# of stages / # of burners (total)	1 / 2	1 / 2	1 / 2	1 / 2
	Connection size	1/2" NPT	1/2" NPT	1/2" NPT	1/2" NPT
	Rollout switch opens / closes	195 / 115	195 / 115	195 / 115	195 / 115
	Temperature rise range (F)	25 – 55	25 – 55	20 – 55	15 – 55
MED	# of stages / # of burners (total)	1 or 2 / 3	1 / 3	1 / 3	1 / 3
	Connection size	1/2" NPT	1/2" NPT	1/2" NPT	1/2" NPT
	Rollout switch opens / closes	195 / 115	195 / 115	195 / 115	195 / 115
	Temperature rise range (F)	55 – 85	35 – 65	30 – 65	25 – 65
HIGH	Connection size	–	1 or 2 / 3	1 or 2 / 3	1 or 2 / 3
	# of stages / # of burners (total)	–	1/2" NPT	1/2" NPT	1/2" NPT
	Rollout switch opens / closes	–	195 / 115	195 / 115	195 / 115
	Temperature rise range (F)	–	50 – 80	40 – 80	35 – 80
Propane Heat					
LOW	# of stages / # of burners (total)	1 / 2	1 / 2	1 / 2	1 / 2
	Connection size	1/2" NPT	1/2" NPT	1/2" NPT	1/2" NPT
	Rollout switch opens / closes	195 / 115	195 / 115	195 / 115	195 / 115
	Temperature rise range (F)	25 – 55	25 – 55	20 – 55	15 – 55
MED	# of stages / # of burners (total)	1 or 2 / 3	1 / 3	1 / 3	1 / 3
	Connection size	1/2" NPT	1/2" NPT	1/2" NPT	1/2" NPT
	Rollout switch opens / closes	195 / 115	195 / 115	195 / 115	195 / 115
	Temperature rise range (F)	55 – 85	35 – 65	30 – 65	25 – 65
HIGH	Connection size	–	1 or 2 / 3	1 or 2 / 3	1 or 2 / 3
	# of stages / # of burners (total)	–	1/2" NPT	1/2" NPT	1/2" NPT
	Rollout switch opens / closes	–	195 / 115	195 / 115	195 / 115
	Temperature rise range (F)	–	50 – 80	40 – 80	35 – 80
Low NO_x Gas Heat					
LOW	# of stages / # of burners (total)	1 / 2	1 / 2	1 / 2	–
	Connection size	1/2" NPT	1/2" NPT	1/2" NPT	–
	Rollout switch opens / closes	195 / 115	195 / 115	195 / 115	–
	Temperature rise range (F)	20 – 50	20 – 50	15 – 50	–
MED	# of stages / # of burners (total)	1 / 3	1 / 3	1 / 3	–
	Connection size	1/2" NPT	1/2" NPT	1/2" NPT	–
	Rollout switch opens / closes	195 / 115	195 / 115	195 / 115	–
	Temperature rise range (F)	30 – 60	30 – 60	25 – 60	–
HIGH	# of stages / # of burners (total)	–	1 / 3	1 / 3	–
	Connection size	–	1/2" NPT	1/2" NPT	–
	Rollout switch opens / closes	–	195 / 115	195 / 115	–
	Temperature rise range (F)	–	40 – 70	35 – 70	–

Table 10 – PHYSICAL DATA (COOLING) 7.5 – 8.5 TONS

		RGS091	RGS090	RGS101	RGS102
Refrigeration System					
# Circuits / # Comp. / Type		1 / 1 / Scroll	2 / 2 / Scroll	1 / 1 / Scroll	2 / 2 / Scroll
RTPF models R-410a charge A/B (lbs – oz)		13 – 12	8 – 5 / 8 – 2	15 – 4	10 – 5 / 10 – 12
Metering device		Fixed Metering Device			
High–press. Trip / Reset (psig)		630 / 505	630 / 505	630 / 505	630 / 505
Low–press. Trip / Reset (psig)		54 / 117	54 / 117	54 / 117	54 / 117
Evap. Coil					
Material		Cu / Al	Cu / Al	Cu / Al	Cu / Al
Coil type		3/8" RTPF	3/8" RTPF	3/8" RTPF	3/8" RTPF
Rows / FPI		3 / 15	3 / 15	3 / 15	3 / 15
total face area (ft ²)		8.9	8.9	11.1	11.1
Condensate drain conn. size		3/4"	3/4"	3/4"	3/4"
Evap. fan and motor					
Standard Static 3 phase	Motor Qty / Drive type	1 / Belt	1 / Belt	1 / Belt	1 / Belt
	Max BHP	1.7	1.7	1.7	1.7
	RPM range	489–747	489–747	518–733	518–733
	motor frame size	56	56	56	56
	Fan Qty / Type	1 / Centrifugal	1 / Centrifugal	1 / Centrifugal	1 / Centrifugal
	Fan Diameter (in)	15 x 15	15 x 15	15 x 15	15 x 15
Medium Static 3 phase	Motor Qty / Drive type	1 / Belt	1 / Belt	1 / Belt	1 / Belt
	Max BHP	2.9	2.9	2.4	2.4
	RPM range	733–949	733–949	690–936	690–936
	motor frame size	56	56	56	56
	Fan Qty / Type	1 / Centrifugal	1 / Centrifugal	1 / Centrifugal	1 / Centrifugal
	Fan Diameter (in)	15 x 15	15 x 15	15 x 15	15 x 15
High Static 3 phase	Motor Qty / Drive type	1 / Belt	1 / Belt	1 / Belt	1 / Belt
	Max BHP	4.7	4.7	3.7	3.7
	RPM range	909–1102	909–1102	838–1084	838–1084
	motor frame size	145TY	145TY	56	56
	Fan Qty / Type	1 / Centrifugal	1 / Centrifugal	1 / Centrifugal	1 / Centrifugal
	Fan Diameter (in)	15 x 15	15 x 15	15 x 15	15 x 15
Cond. Coil					
Material		Cu / Al	Cu / Al	Cu / Al	Cu / Al
Coil type		3/8" RTPF*	3/8" RTPF*	3/8" RTPF*	3/8" RTPF*
Rows / FPI		2 / 17	2 / 17	2 / 17	2 / 17
Total Face Area (ft ²)		20.5	20.5	21.4	25.1
Cond. fan / motor					
Qty / Motor drive type		2 / direct	2 / direct	2 / direct	2 / direct
Motor HP / RPM		1/4 / 1100	1/4 / 1100	1/4 / 1100	1/4 / 1100
Fan diameter (in)		22	22	22	22
Filters					
RA Filter # / size (in)		4 / 16 x 20 x 2	4 / 16 x 20 x 2	4 / 20 x 20 x 2	4 / 20 x 20 x 2
OA inlet screen # / size (in)		1 / 20 x 24 x 1	1 / 20 x 24 x 1	1 / 20 x 24 x 1	1 / 20 x 24 x 1
* RTPF – Round Tube Plate Fin Coil Design					

Table 11 – PHYSICAL DATA (COOLING) 10 – 15 TONS

		RGS121	RGS120	RGS150	RGS180
Refrigeration System					
# Circuits / # Comp. / Type		1 / 1 / Scroll	2 / 2 / Scroll	2 / 2 / Scroll	2 / 2 / Scroll
RTPF models R-410a charge A/B (lbs – oz)		20 – 0	10 – 5 / 10 – 3	11 – 0 / 11 – 6	15–14/16–12
Metering device			Fixed Orifice		
High–press. Trip / Reset (psig)		630 / 505	630 / 505	630 / 505	630 / 505
Low–press. Trip / Reset (psig)		54 / 117	54 / 117	54 / 117	54 / 117
Loss of charge Trip / Reset (psig)		–			–
Evap. Coil					
Material		Cu / Al	Cu / Al	Cu / Al	Cu / Al
Coil type		3/8" RTPF	3/8" RTPF	3/8" RTPF	3/8" RTPF
Rows / FPI		4 / 15	4 / 15	4 / 15	3 / 15
total face area (ft ²)		11.1	11.1	11.1	17.5
Condensate drain conn. size		3/4"	3/4"	3/4"	3/4"
Evap. fan and motor					
Standard Static 3 Phase	Motor Qty / Drive type	1 / Belt	1 / Belt	1 / Belt	1 / Belt
	Max BHP	2.4	2.4	2.9	2.9
	RPM range	591–838	591–838	652–843	507–676
	motor frame size	56	56	56	56
	Fan Qty / Type	1 / Centrifugal	1 / Centrifugal	1 / Centrifugal	1 / Centrifugal
	Fan Diameter (in)	15 x 15	15 x 15	15 x 15	18 x 18
Medium Static 3 Phase	Motor Qty / Drive type	1 / Belt	1 / Belt	1 / Belt	1 / Belt
	Max BHP	3.7	3.7	3.7	3.7
	RPM range	838–1084	838–1084	838–1084	627–851
	motor frame size	56	56	56	56
	Fan Qty / Type	1 / Centrifugal	1 / Centrifugal	1 / Centrifugal	1 / Centrifugal
	Fan Diameter (in)	15 x 15	15 x 15	15 x 15	18 x 18
High Static 3 Phase	Motor Qty / Drive type	1 / Belt	1 / Belt	1 / Belt	–
	Max BHP	4.7	4.7	4.7	–
	RPM range	1022–1240	1022–1240	1022–1240	–
	motor frame size	14	14	14	–
	Fan Qty / Type	1 / Centrifugal	1 / Centrifugal	1 / Centrifugal	–
	Fan Diameter (in)	15 x 15	15 x 15	15 x 15	–
High Static High Efficiency 3 Phase*	Motor Qty / Drive type	–	–	–	1 / Belt
	Max BHP	–	–	–	6.1
	RPM range	–	–	–	776–955
	motor frame size	–	–	–	S184T
	Fan Qty / Type	–	–	–	1 / Centrifugal
	Fan Diameter (in)	–	–	–	18 x 18
Cond. Coil					
Material		Cu / Al	Cu / Al	Cu / Al	Cu / Al
Coil type		3/8" RTPF	3/8" RTPF	3/8" RTPF	3/8" RTPF
Rows / FPI		2 / 17	2 / 17	3 / 17	2/17
total face area (ft ²)		25.1	25.1	25.1	2 @ 23.1
Cond. fan / motor					
Qty / Motor drive type		2 / direct	2 / direct	1 / direct	3 / direct
Motor HP / RPM		1/4 / 1100	1/4 / 1100	1 / 1175	1/4 / 1100
Fan diameter (in)		22	22	30	22
Filters					
RA Filter # / Size (in)		4 / 20 x 20 x 2	4 / 20 x 20 x 2	4 / 20 x 20 x 2	16 / 18 x 24 x 2 V2 / 24 x 27 x 1
OA inlet screen # / Size (in)		1 / 20 x 24 x 1	1 / 20 x 24 x 1	1 / 20 x 24 x 1	H1 / 30 x 39 x 1

* Section 313 of the Energy Independence and Security Act of 2007 (EISA 2007) mandates that the efficiency of general purpose motors used in Light Commercial Rooftops rated at 5.0 HP and larger be increased on or after December 19, 2010. High and standard efficiency motors will be offered until inventory is depleted, at which time only high efficiency motors will be available.

Table 12 – PHYSICAL DATA (HEATING) 7.5 – 15 TONS

Gas Connection		RGS090/091	RGS101/102	RGS120/121
		# of Gas Valves	1	1
Nat. gas supply line press (in. w.g.)/(PSIG)		4 –13 / 0.18 – 0.47	4 –13 / 0.18 – 0.47	4 –13 / 0.18 – 0.47
Propane supply line press (in. w.g.)/(PSIG)		11 –13 / 0.40 – 0.47	11 –13 / 0.40 – 0.47	11 –13 / 0.40 – 0.47
Heat Anticipator Setting (Amps)				
1st stage		0.14	0.14	0.14
2nd stage		0.14	0.14	0.14
Natural Gas				
LOW	# of stages / # of burners (total)	1 / 3	1 / 3	2 / 4
	Connection size	1/2" NPT	1/2" NPT	3/4" NPT
	Rollout switch opens / closes	195 / 115	195 / 115	195 / 115
	Temperature rise range (F)	20 – 50	20 – 50	25 – 65
MED	# of stages / # of burners (total)	2 / 4	2 / 4	2 / 5
	Connection size	3/4" NPT	3/4" NPT	3/4" NPT
	Rollout switch opens / closes	195 / 115	195 / 115	195 / 115
	Temperature rise range (F)	35 – 65	30 – 65	30 – 65
HIGH	# of stages / # of burners (total)	2 / 5	2 / 5	2 / 5
	Connection size	3/4" NPT	3/4" NPT	3/4" NPT
	Rollout switch opens / closes	195 / 115	195 / 115	195 / 115
	Temperature rise range (F)	45 – 75	40 – 75	35 – 70
Propane Heat				
LOW	# of stages / # of burners (total)	1 / 3	1 / 3	2 / 4
	Connection size	1/2" NPT	1/2" NPT	3/4" NPT
	Rollout switch opens / closes	195 / 115	195 / 115	195 / 115
	Temperature rise range (F)	20 – 50	20 – 50	25 – 65
MED	# of stages / # of burners (total)	2 / 4	2 / 4	2 / 5
	Connection size	3/4" NPT	3/4" NPT	3/4" NPT
	Rollout switch opens / closes	195 / 115	195 / 115	195 / 115
	Temperature rise range (F)	35 – 65	30 – 65	30 – 65
HIGH	# of stages / # of burners (total)	2 / 5	2 / 5	2 / 5
	Connection size	3/4" NPT	3/4" NPT	3/4" NPT
	Rollout switch opens / closes	195 / 115	195 / 115	195 / 115
	Temperature rise range (F)	45 – 75	40 – 75	35 – 70

Table 13 – PHYSICAL DATA (HEATING) 7.5 – 15 TONS (Cont.)

		RGS150	RGS180
Gas Connection	# of Gas Valves	1	1
	Nat. gas supply line press (in. w.g.) / (PSIG)	4 – 13 / 0.18 – 0.47	5 – 13 / 0.18 – 0.47
	LP supply line press (in. w.g.) / (PSIG)	11 – 13 / 0.40 – 0.47	11 – 13 / 0.40 – 0.47
Heat Anticipator setting (Amps)	1st stage	0.14	0.14
	2nd stage	0.14	0.14
Natural Gas Heat			
LOW	# of stages / # of burners (total)	2 / 4	2 / 6
	Connection Size	3/4" NPT	3/4" NPT
	Rollout switch opens / closes	195 / 115	225 / 145
	Temperature Rise	25 – 65	20 – 55
MEDIUM	# of stages / # of burners (total)	2 / 5	2 / 8
	Connection Size	3/4" NPT	3/4" NPT
	Rollout switch opens / closes	195 / 115	225 / 145
	Temperature Rise	30 – 65	25 – 60
HIGH	# of stages / # of burners (total)	2 / 5	2 / 10
	Connection Size	3/4" NPT	3/4" NPT
	Rollout switch opens / closes	195 / 115	225 / 145
	Temperature Rise	35 – 70	35 – 65
Propane Heat			
LOW	# of stages / # of burners (total)	2 / 4	2 / 6
	Connection Size	3/4" NPT	3/4" NPT
	Rollout switch opens / closes	195 / 115	225 / 145
	Temperature Rise	25 – 65	20 – 55
MEDIUM	# of stages / # of burners (total)	2 / 5	2 / 8
	Connection Size	3/4" NPT	3/4" NPT
	Rollout switch opens / closes	195 / 115	225 / 145
	Temperature Rise	30 – 65	25 – 60
HIGH	# of stages / # of burners (total)	2 / 5	2 / 10
	Connection Size	3/4" NPT	3/4" NPT
	Rollout switch opens / closes	195 / 115	225 / 145
	Temperature Rise	35 – 70	35 – 65

BASE UNIT DIMENSIONS – RGS036–072

NOTES:

1. DIMENSIONS ARE IN INCHES. DIMENSIONS IN [] ARE IN MILLIMETERS.
2. CENTER OF GRAVITY
3. DIRECTION OF AIR FLOW

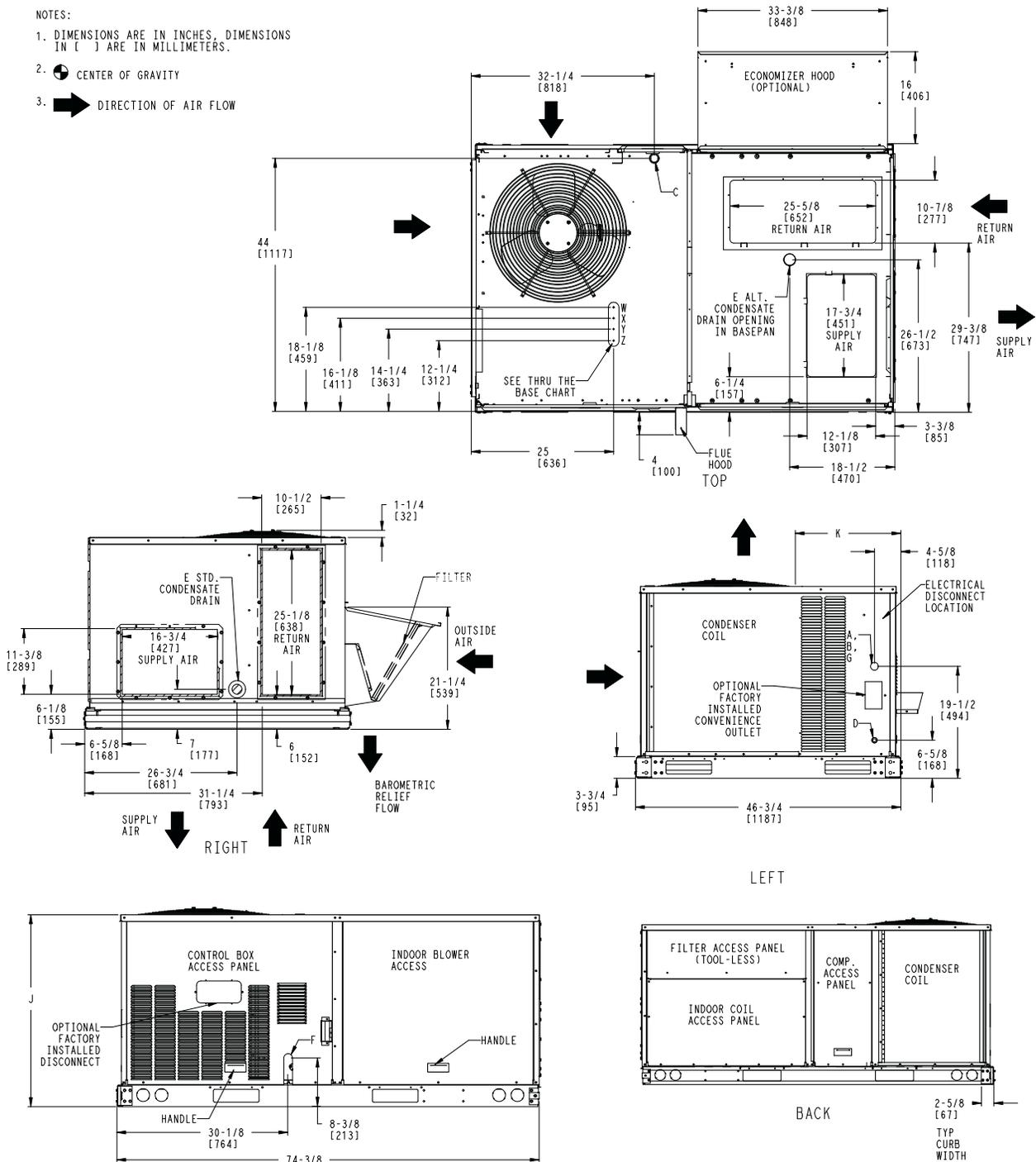

CONNECTION SIZES	
A	1 3/8" [35] DIA. FIELD POWER SUPPLY HOLE
B	2" [50] DIA. POWER SUPPLY KNOCKOUT
C	1 3/4" [51] DIA. GAUGE ACCESS PLUG
D	7/8" [22] DIA. FIELD CONTROL WIRING HOLE
E	3/4"-14 NPT CONDENSATE DRAIN
F	1/2"-14 NPT GAS CONNECTION
G	2 1/2" [64] DIA. POWER SUPPLY KNOCK-OUT

THRU-THE-BASE CHART THESE HOLES REQUIRED FOR USE CRBTMPWR001A01, 003A01			
	THREADED CONDUIT SIZE	WIRE USE	REQ'D HOLE SIZES (MAX.)
W	1/2"	ACC.	7/8" [22.2]
X	1/2"	24V	7/8" [22.2]
Y *	3/4" (001,003)	POWER	1 1/8" [28.4]
Z **	(003) 1/2" FPT	GAS	1 3/16" [30.0]
FOR "THRU-THE-BASEPAN" FACTORY OPTION, FITTINGS FOR ONLY X, Y, & Z ARE PROVIDED			
*	SELECT EITHER 3/4" OR 1/2" FOR POWER, DEPENDING ON WIRE SIZE		
**	(001) PROVIDES 3/4" FPT THRU CURB FLANGE & FITTING.		

UNIT	J	K
036	33 3/8 [847]	18 5/8 [472]
048	33 3/8 [847]	14 7/8 [377]
060	33 3/8 [847]	14 7/8 [377]
072	41 3/8 [1051]	14 7/8 [377]

A10484

WEIGHT & CLEARANCE DIMENSIONS – RGS036–072 (cont.)

UNIT	BASE UNIT WEIGHT		Corner Weight A		Corner Weight B		Corner Weight C		Corner Weight D		Center of Gravity In [mm]		
	LBS	KG	LBS	KG	LBS	KG	LBS	KG	LBS	KG	X	Y	Z
RGS036	483	219	111	50	125	57	131	59	116	53	39 [991]	23 [584]	16–3/8 [416]
RGS048	537	244	124	56	139	63	145	66	129	59	39 [991]	23 [584]	17 [432]
RGS060	569	258	131	59	147	67	154	70	137	62	39 [991]	23 [584]	17–1/4 [438]
RGS072	652	296	150	68	169	76	176	80	157	71	39 [991]	23 [584]	20–1/8 [511]

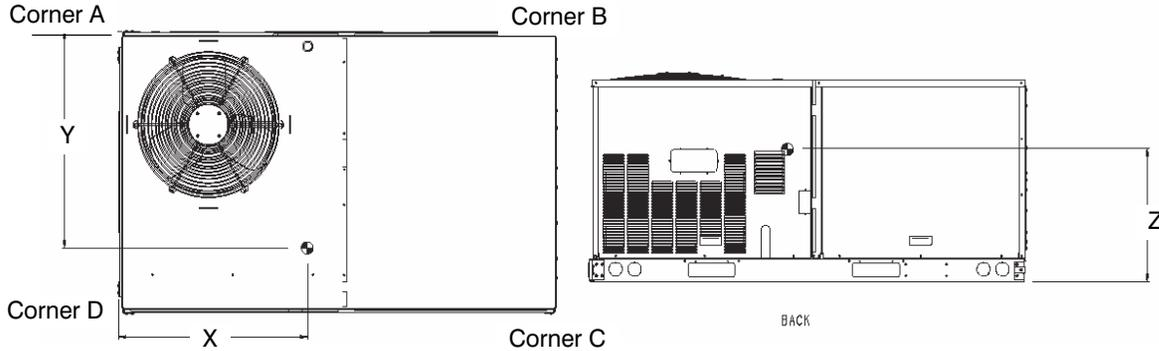

UNIT CLEARANCES

LOC	DIMENSION	CONDITION
A	48" (1219 mm) 18" (457 mm) 18" (457 mm) 12" (305 mm)	Unit disconnect is mounted on panel No disconnect, convenience outlet option Recommended service clearance Minimum clearance
B	42" (1067 mm) 36" (914 mm) Special	Surface behind servicer is grounded (e.g., metal, masonry wall) Surface behind servicer is electrically non-conductive (e.g., wood, fiberglass) Check for sources of flue products within 10–ft of unit fresh air intake hood
C	36" (914 mm) 18" (457 mm)	Side condensate drain is used Minimum clearance
D	48" (1219 mm) 42" (1067 mm) 36" (914 mm) Special	No flue discharge accessory installed, surface is combustible material Surface behind servicer is grounded (e.g., metal, masonry wall, another unit) Surface behind servicer is electrically non-conductive (e.g., wood, fiberglass) Check for adjacent units or building fresh air intakes within 10–ft of this unit's flue outlet

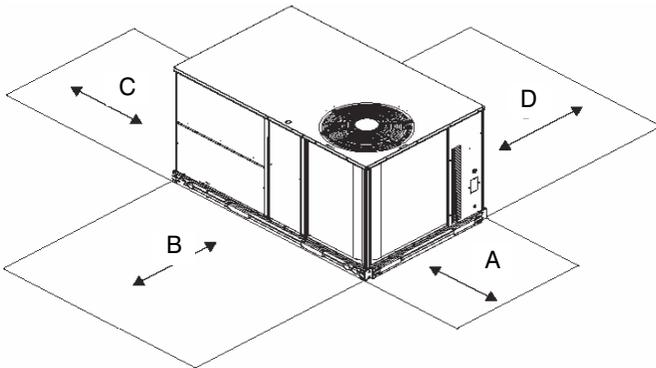

ROOF CURB DETAILS - RGS036-072

Roof Curb Accessory	A	Unit Size
CRRFCURB001A01	1' 2" [356]	RGS036-072
CRRFCURB002A01	2' 0" [610]	

NOTES:

1. Roofcurb accessory is shipped disassembled.
2. Insulated panels, 1" thick polyurethane foam, 1-3/4# density.
3. Dimensions in. [] in millimeters.
4. Roofcurb 16ga steel.
5. Attach ductwork to curb (Flanges of duct rest on curb)
6. Service clearance 4' on each side.
7. ➡ Direction of airflow.
8. Connector pkg. CRBTMPWR001A01 is for thru-the-curb connections. Pkg. CRBTMPWR003A01 is for thru-the-bottom connections.

Connector Pkg. Acc.	B	C	D Alt. Drain Hole	Gas	Power	Control	Accessory Power
CRBTMPWR001A01	1' 9-11/16" [551]	1' 4" [406]	1-3/4" [44.5]	3/4" [19] NPT	3/4" [19] NPT	1/2" [12.7] NPT	1/2" [12.7] NPT
CRBTMPWR003A01				1/2" [12.7] NPT			

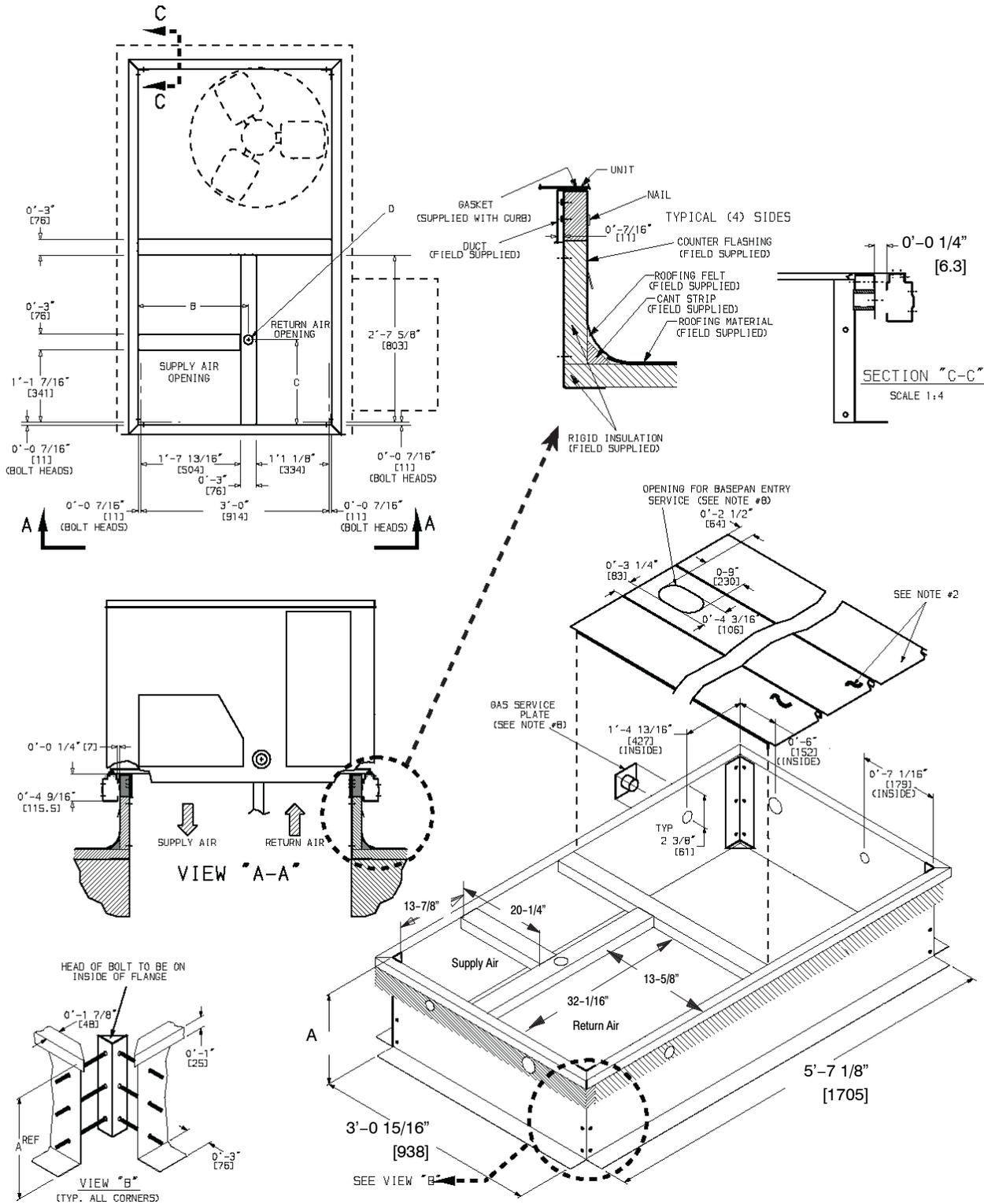

BASE UNIT DIMENSIONS – RGS090–121

NOTES:

1. DIMENSIONS ARE IN INCHES, DIMENSIONS IN () ARE IN MILLIMETERS.

2.  CENTER OF GRAVITY

3.  DIRECTION OF AIR FLOW

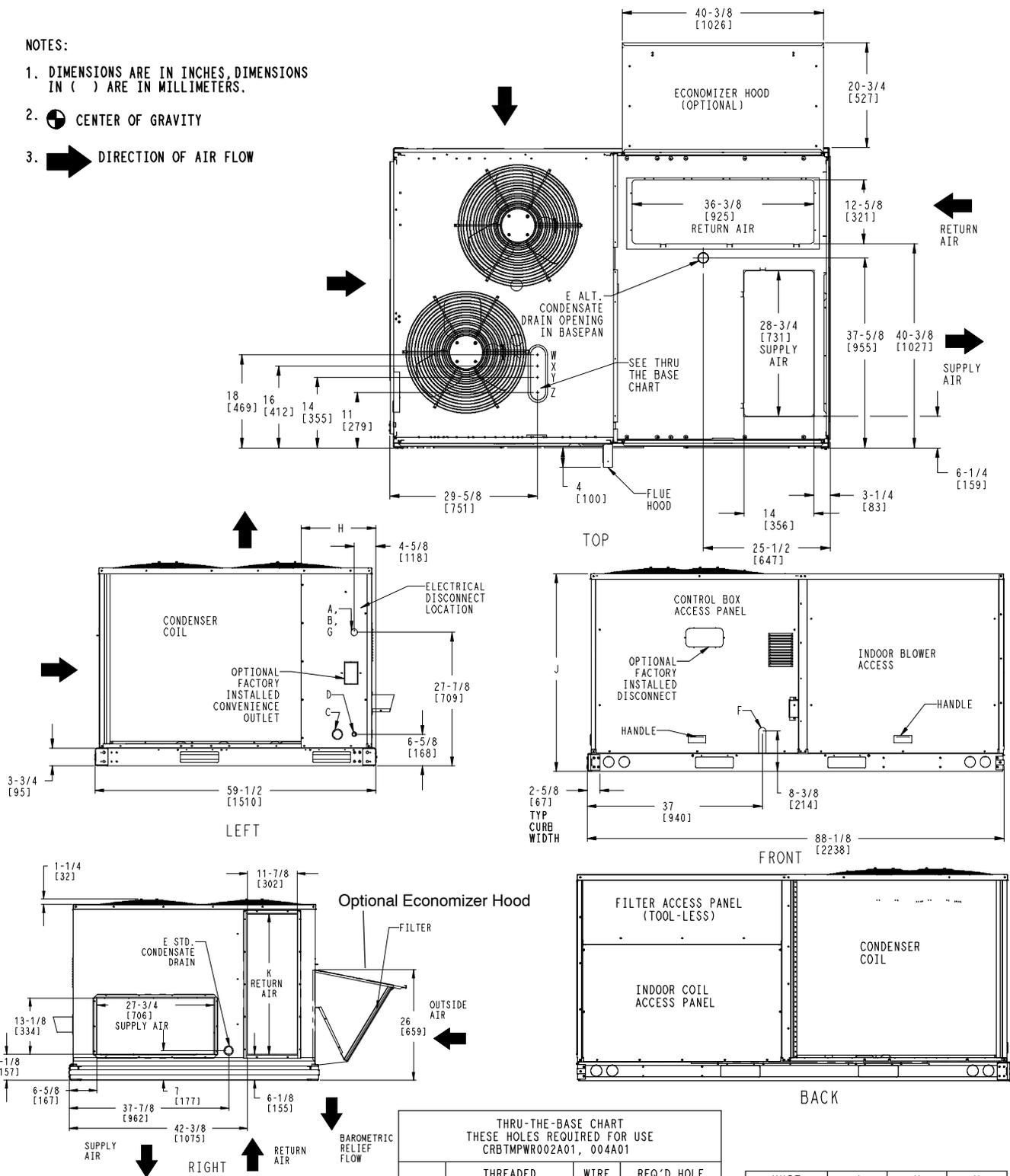

CONNECTION SIZES		
A	1 3/8" DIA [35]	FIELD POWER SUPPLY HOLE
B	2 1/2" [64] DIA	POWER SUPPLY KNOCKOUT
C	1 3/4" DIA [51]	GAUGE ACCESS PLUG
D	7/8" DIA [22]	FIELD CONTROL WIRING HOLE
E	3/4"-14 NPT	CONDENSATE DRAIN
F	1/2"-14 NPT	GAS CONNECTION
F	3/4"-14 NPT	GAS CONNECTION
G	2" DIA [51]	POWER SUPPLY KNOCK-OUT

THRU-THE-BASE CHART THESE HOLES REQUIRED FOR USE CRBTMPWR002A01, 004A01		
	THREADED CONDUIT SIZE	WIRE USE
W	1/2"	ACC.
X	1/2"	24V
Y	1 1/4" (002,004)	POWER
Z **, *	(004) 3/4" FPT	GAS
FOR "THRU-THE-BASEPAN" FACTORY OPTION, FITTINGS FOR ONLY X, Y, & Z ARE PROVIDED		
FOR HEAT SIZES "D" & "S" - A FIELD SUPPLIED 1/2" ADAPTER IS REQUIRED BETWEEN BASE PAN FITTING AND GAS VALVE.		
*	(002) PROVIDES 3/4" FPT THRU CURB FLANGE & FITTING.	
**	(002) PROVIDES 3/4" FPT THRU CURB FLANGE & FITTING.	

UNIT	J	K	H
091	41 1/4 [1048]	33 [658]	15 7/8 [403]
101	49 3/8 [1253]	37 1/4 [946]	23 7/8 [609]
121	49 3/8 [1253]	37 1/4 [946]	15 7/8 [403]
090	41 1/4 [1048]	33 [658]	15 7/8 [403]
102	49 3/8 [1253]	37 1/4 [946]	15 7/8 [403]
120	49 3/8 [1253]	37 1/4 [946]	15 7/8 [403]

WEIGHT & CLEARANCE DIMENSIONS – RGS090–121 (cont.)

UNIT	BASE UNIT WEIGHT		Corner Weight A		Corner Weight B		Corner Weight C		Corner Weight D		Center of Gravity In [mm]		
	LBS	KG	LBS	KG	LBS	KG	LBS	KG	LBS	KG	X	Y	Z
RGS091	780	354	178	81	158	72	209	95	236	107	42 [1064]	34 [860]	21 [521]
RGS101	920	418	212	96	183	83	243	110	282	128	41 [1051]	34 [860]	23 [581]
RGS121	930	422	216	98	196	89	241	112	272	124	42 [1067]	33 [841]	24 [613]
RGS090	835	379	164	75	170	77	255	116	246	111	45 [1140]	36 [905]	19 [473]
RGS102	930	422	228	104	187	85	232	105	283	129	40 [1010]	33 [835]	19 [473]
RGS120	940	427	231	105	189	86	234	106	286	130	40 [1010]	33 [835]	19 [473]

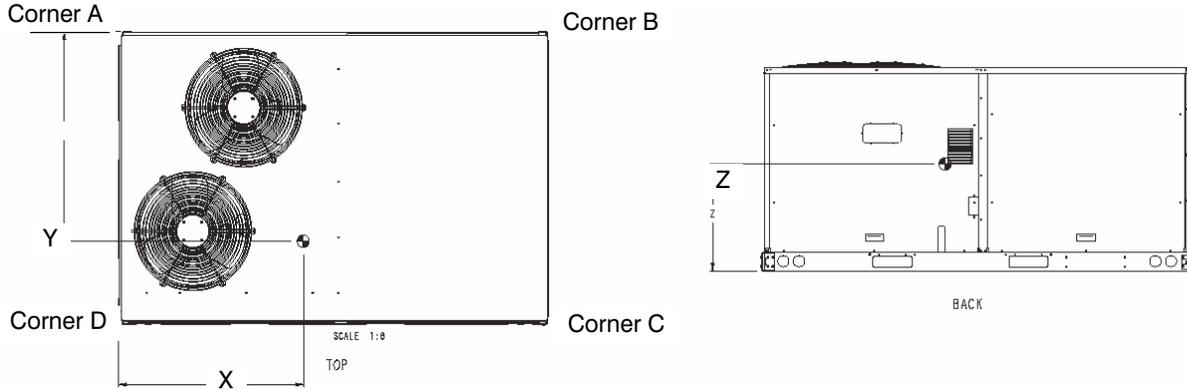

UNIT CLEARANCES

LOC	DIMENSION	CONDITION
A	48" (1219 mm)	Unit disconnect is mounted on panel
	36" (914 mm)	If dimension-B is 12"
	18" (457 mm)	No disconnect, convenience outlet option
	18" (457 mm)	Recommended service clearance (use electric screwdriver)
	12" (305 mm)	Minimum clearance (use manual ratchet screwdriver)
B	36" (914 mm)	Unit has economizer
	12" (305 mm)	If dimension-A is 36"
	Special	Check for sources of flue products within 10-ft of unit fresh air intake hood
C	36" (914 mm)	Side condensate drain is used
	18" (457 mm)	Minimum clearance
D	48" (1219 mm)	No flue discharge accessory installed, surface is combustible material
	42" (1067 mm)	Surface behind servicer is grounded (e.g., metal, masonry wall, another unit)
	36" (914 mm)	Surface behind servicer is electrically non-conductive (e.g., wood, fiberglass)
	Special	Check for adjacent units or building fresh air intakes within 10-ft of this unit's flue outlet

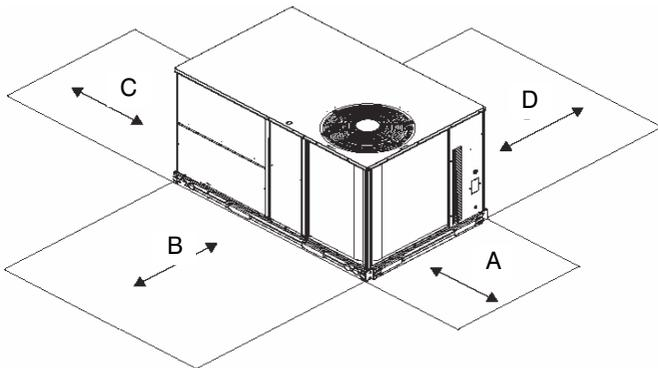

ROOF CURB DETAILS – RGS090 – 150

Roof Curb Accessory	A	Unit Size
CRRFCURB003A01	1' 2" [356]	RGS090-150
CRRFCURB004A01	2' 0" [610]	

NOTES:

1. Roofcurb accessory is shipped disassembled.
2. Insulated panels, 1" thick polyurethane foam, 1-3/4# density.
3. Dimensions in. [] in millimeters.
4. Roofcurb 16ga steel.
5. Attach ductwork to curb (Flanges of duct rest on curb)
6. Service clearance 4' on each side.
7. ➔ Direction of airflow.
8. Connector pkg. CRBTMPWR002A01 is for thru-the-curb connections. Pkg. CRBTMPWR004A01 is for thru-the-bottom connections.

Connector Pkg. Acc.	B	C	D Alt. Drain Hole	Gas	Power	Control	Accessory Power
CRBTMPWR002A01	2' 8-7/16" [827]	1' 10-15/16" [583]	1-3/4" [44.5]	3/4" [19] NPT	1-1/4" [31.7] NPT	1/2" [12.7] NPT	1/2" [12.7] NPT
CRBTMPWR004A01							

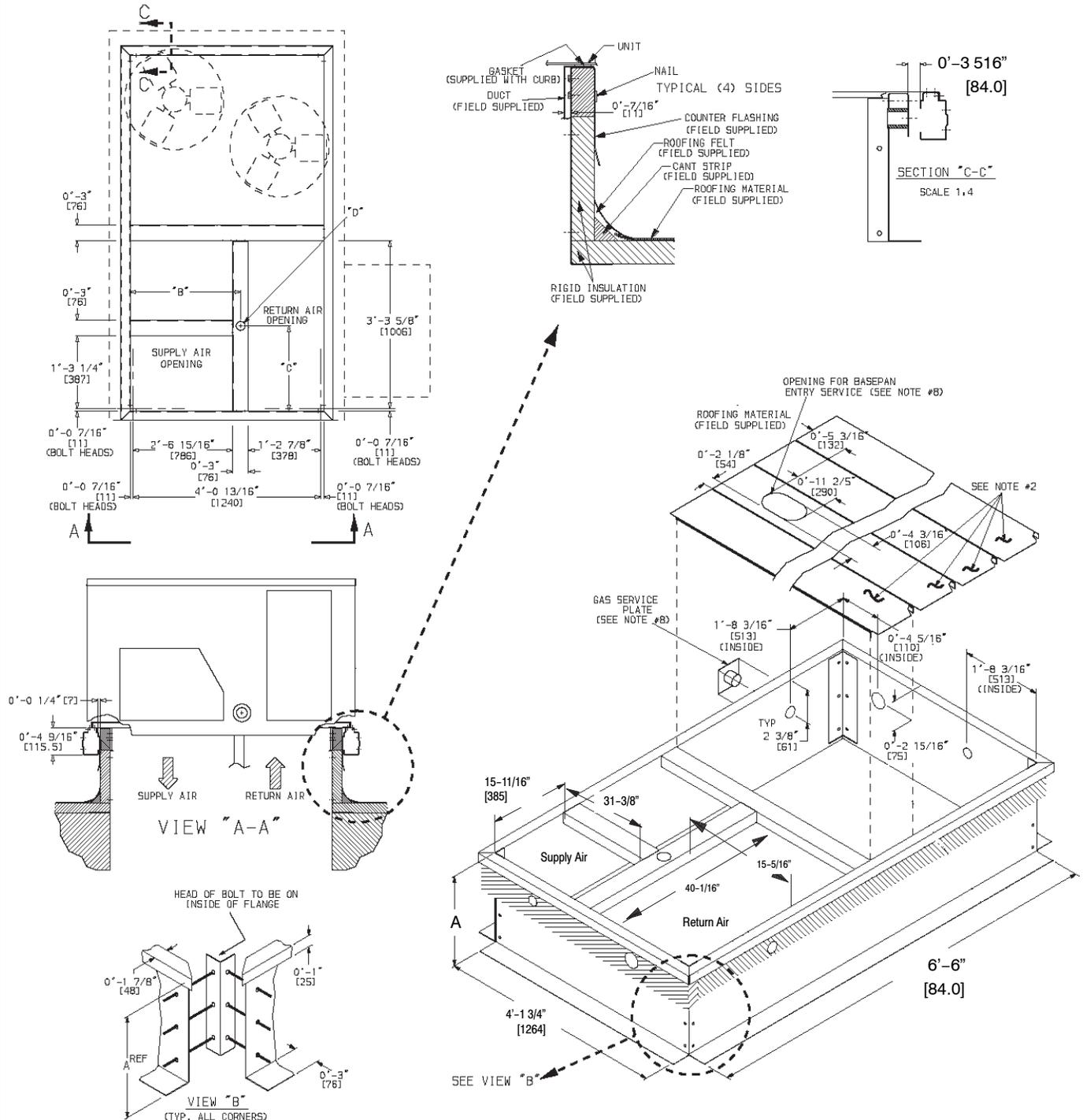

BASE UNIT DIMENSIONS – RGS150

NOTES:

1. DIMENSIONS ARE IN INCHES, DIMENSIONS IN () ARE IN MILLIMETERS.
2.  CENTER OF GRAVITY
3.  DIRECTION OF AIR FLOW

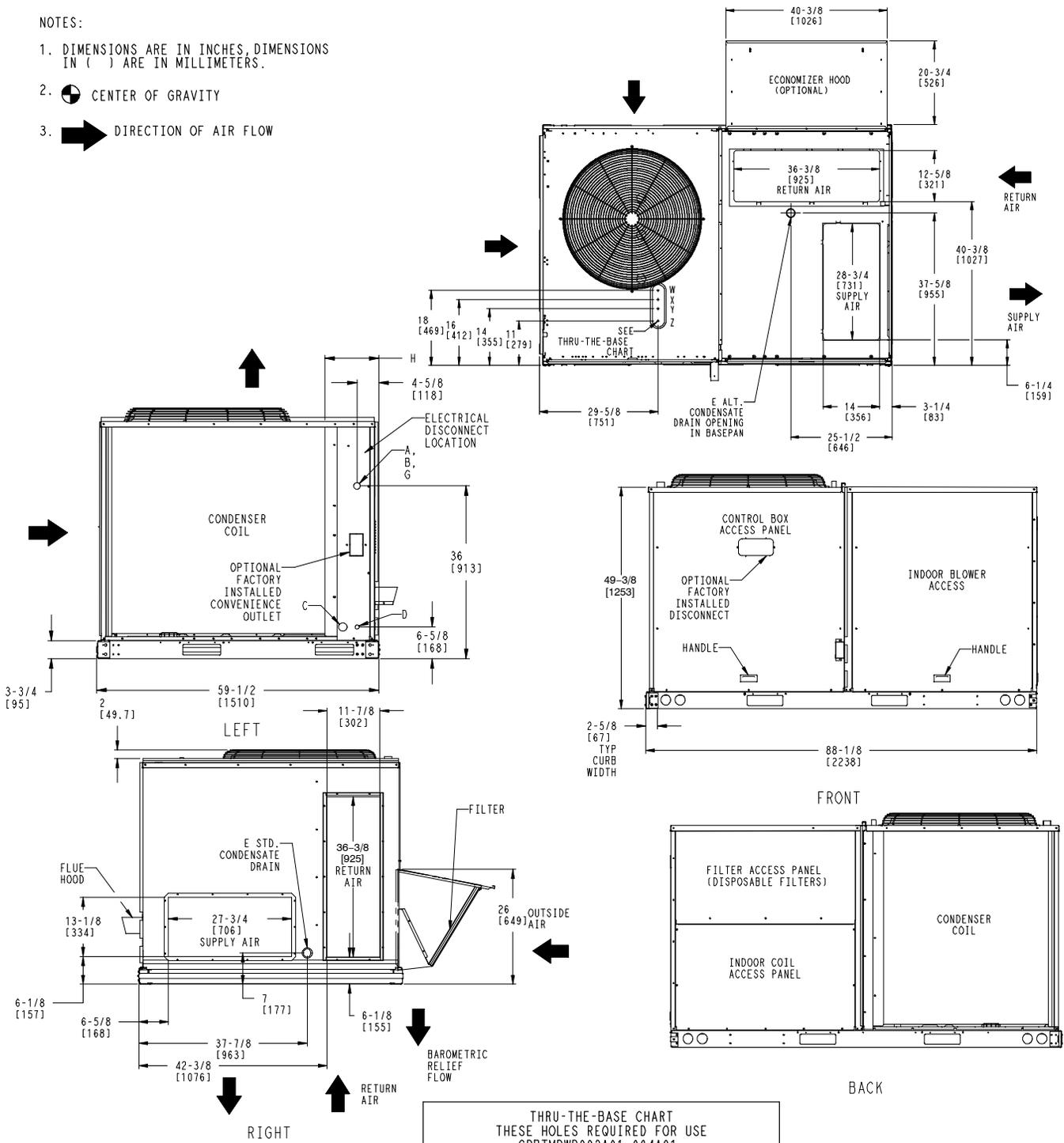

CONNECTION SIZES	
A	1 3/8" [35] DIA FIELD POWER SUPPLY HOLE
B	2 1/2" [64] DIA POWER SUPPLY KNOCKOUT
C	1 3/4" [51] DIA GAUGE ACCESS PLUG
D	7/8" [22] DIA FIELD CONTROL WIRING HOLE
E	3/4"-14 NPT CONDENSATE DRAIN
F	3/4"-14 NPT GAS CONNECTION
G	2" [51] DIA POWER SUPPLY KNOCK-OUT

THRU-THE-BASE CHART THESE HOLES REQUIRED FOR USE CRBTMPWR002A01, 004A01			
	THREADED CONDUIT SIZE	WIRE USE	REQ'D HOLE SIZES (MAX.)
W	1/2"	ACC.	7/8" (22.2)
X	1/2"	24V	7/8" (22.2)
Y	1 1/4" (002,004)	POWER	1 3/4" (44.4)
Z*	(004) 3/4" FPT	GAS	1 5/8" (41.3)
FOR "THRU-THE-BASEPAN" FACTORY OPTION, FITTINGS FOR ONLY X, Y, & Z ARE PROVIDED			
*	(002) PROVIDES 3/4" FPT THRU CURB FLANGE & FITTING.		

UNIT	H
150	15-7/8 [403]

WEIGHT & CLEARANCE DIMENSIONS – RGS150 (cont.)

UNIT	BASE UNIT WEIGHT		Corner Weight A		Corner Weight B		Corner Weight C		Corner Weight D		Center of Gravity In [mm]		
	LBS	KG	LBS	KG	LBS	KG	LBS	KG	LBS	KG	X	Y	Z
RGS150	1167	530	349	159	167	76	211	96	440	200	31–3/8 [797]	34–1/4 [870]	21–7/8 [556]

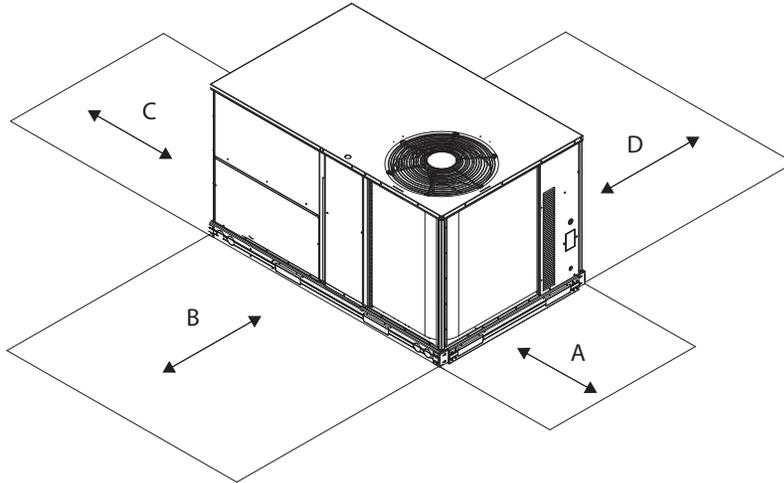
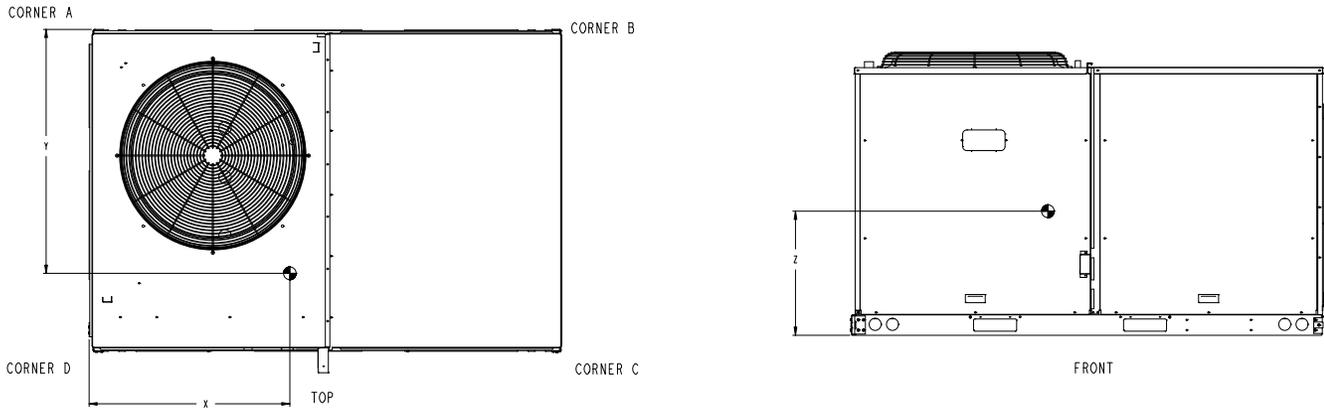

LOC	DIMENSION	CONDITION
A	48" (1219 mm)	Unit disconnect is mounted on panel
	36" (914 mm)	If dimension–B is 12" (305 mm)
	18" (457 mm)	No disconnect, convenience outlet option
	18" (457 mm)	Recommended service clearance (use electric screwdriver)
	12" (305 mm)	Minimum clearance (use manual ratchet screwdriver)
B	36" (914 mm)	Unit has economizer
	12" (305 mm)	If dimension–A is 36" (914 mm)
	Special	Check for sources of flue products within 10–ft of unit fresh air intake hood
C	36" (914 mm)	Side condensate drain is used
	18" (457 mm)	Minimum clearance
D	48" (1219 mm)	No flue discharge accessory installed, surface is combustible material
	42" (1067 mm)	Surface behind servicer is grounded (e.g., metal, masonry wall, another unit)
	36" (914 mm)	Surface behind servicer is electrically non–conductive (e.g., wood, fiberglass)
	Special	Check for adjacent units or building fresh air intakes within 10–ft of this unit's flue outlet

BASE UNIT DIMENSIONS – RGS180

NOTES:

1. DIMENSIONS ARE IN INCHES. DIMENSIONS IN [] ARE IN MILLIMETERS.
2.  CENTER OF GRAVITY
3.  DIRECTION OF AIR FLOW

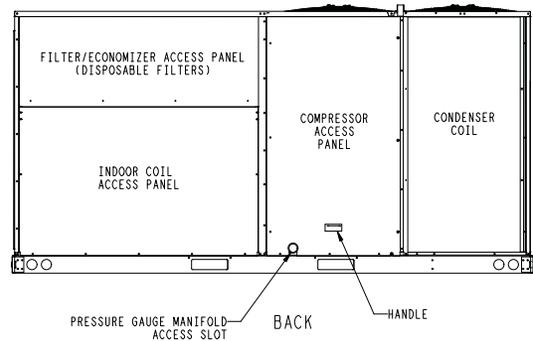
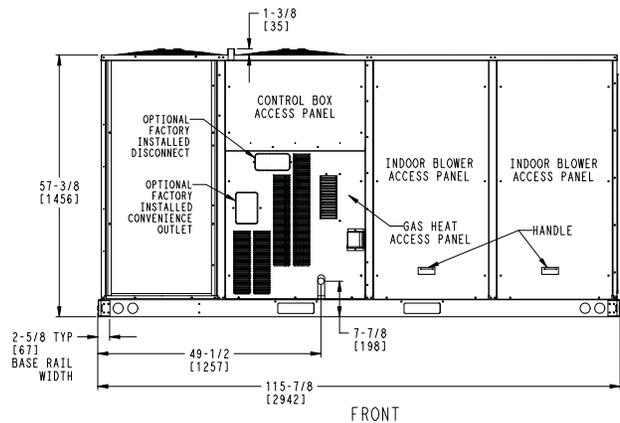
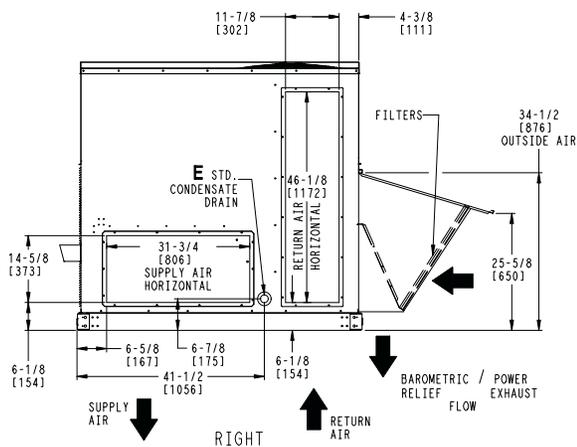
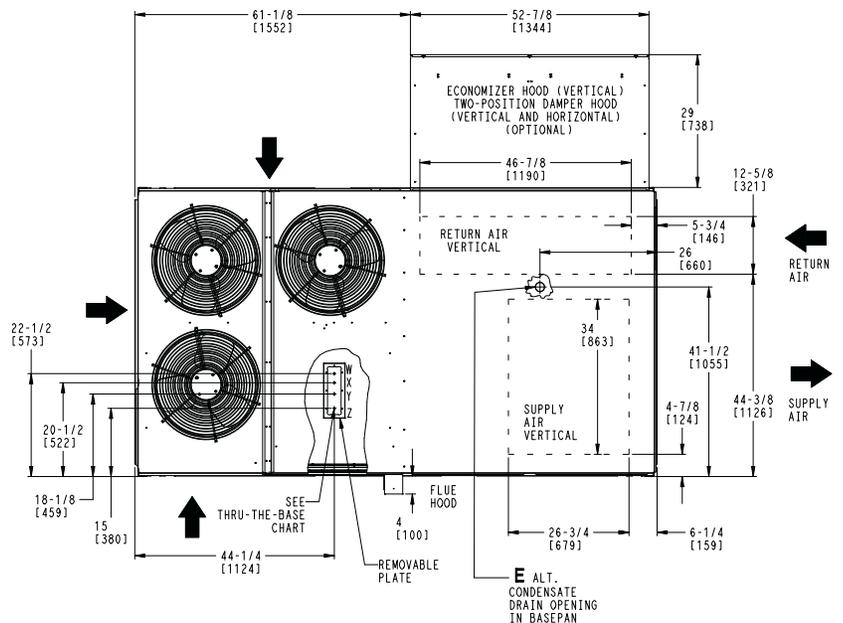
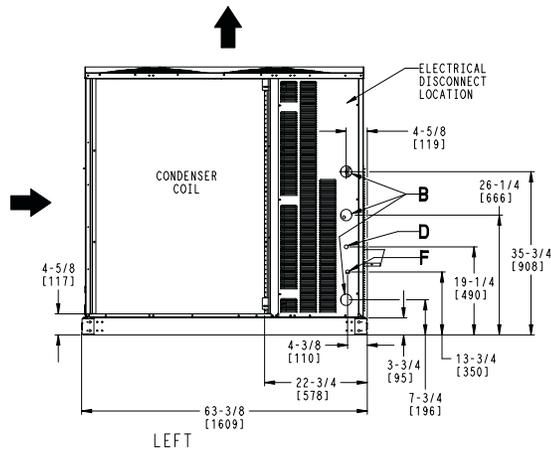

THRU-THE-BASE CHART
THESE HOLES REQUIRED FOR USE
CRBTMPWR005A00, 006A00, 007A00

ACCESSORY NO.		THREADED CONDUIT SIZE	WIRE USE	REQ'D HOLE SIZES (MAX.)
005	W	1/2"	ACC.	7/8" [22.2]
	X	1/2"	24V	7/8" [22.2]
	Y	1 1/4"	POWER	1 1/2" [38.1]
	Z	3/4" PIPE	GAS	1 3/4" [44.5]
006	W	1/2"	ACC.	7/8" [22.2]
	X	1/2"	24V	7/8" [22.2]
	Y	1 1/2"	POWER	2" [50.8]
007	Z	3/4" PIPE	GAS	1 3/4" [44.5]
	W	1/2"	ACC.	7/8" [22.2]
	X	1/2"	24V	7/8" [22.2]
	Y	2"	POWER	2 1/2" [63.5]
	Z	3/4" PIPE	GAS	1 3/4" [44.5]

FOR "THRU-THE-BASEPAN" FACTORY OPTION,
FITTINGS FOR X & Y ARE PROVIDED AS
SPECIFIED ON "006".

CONNECTION SIZES	
B	2 1/2" [64] DIA POWER SUPPLY HOLE
D	7/8" [22] DIA FIELD CONTROL WIRING HOLE
E	3/4"-14 NPT CONDENSATE DRAIN
F	7/8" [22] DIA FIELD CONVENIENCE OUTLET HOLE

A10488

WEIGHT & CLEARANCE DIMENSIONS – RGS180 (cont.)

RGS 180	STD. UNIT WEIGHT		CORNER WEIGHT (A)		CORNER WEIGHT (B)		CORNER WEIGHT (C)		CORNER WEIGHT (D)		C.G.	
	LBS.	KG.	LBS.	KG.	LBS.	KG.	LBS.	KG.	LBS.	KG.	X	Y
	1380	627	295	134	276	126	342	156	421	191	64 1/4 [1630]	35 [890]
												21 1/8 [537]

STANDARD UNIT WEIGHT IS WITHOUT MAX. GAS HEAT & WITHOUT PACKAGING. FOR OPTIONS & ACCESSORIES, REFER TO THE PRODUCT DATA CATALOG.

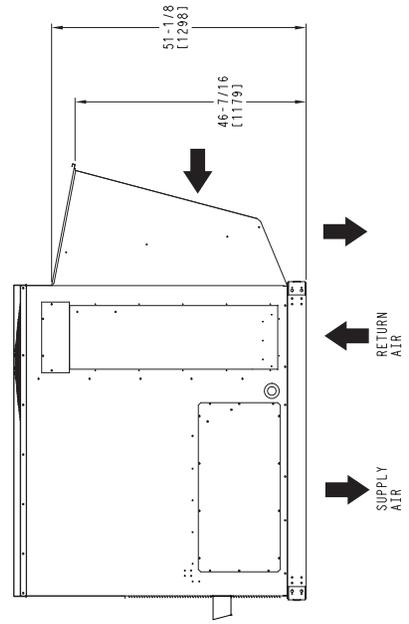
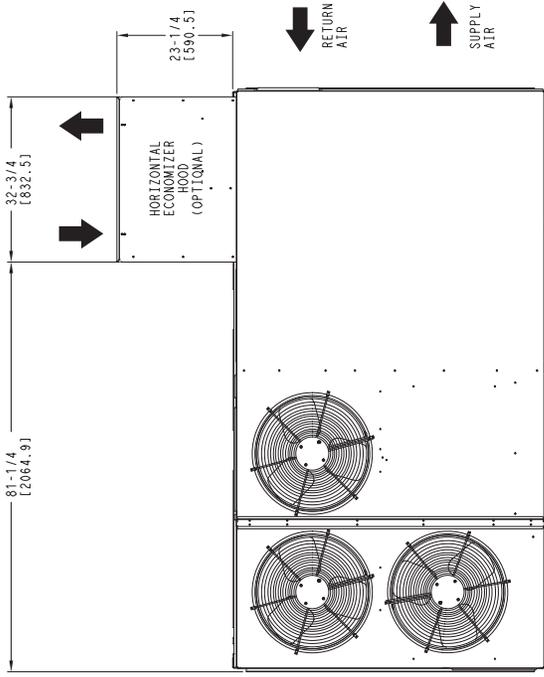

HORIZONTAL ECONOMIZER

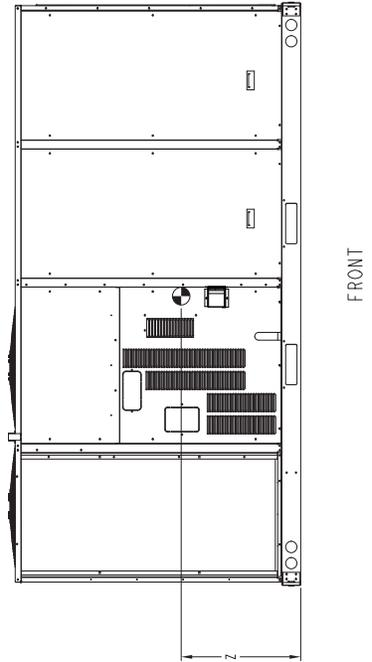
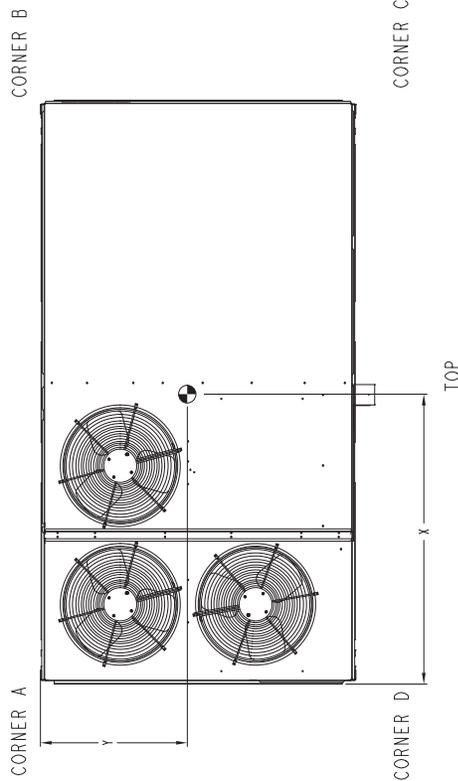

C101232C

OPTIONS & ACCESSORY WEIGHTS

OPTION / ACCESSORY	OPTION / ACCESSORY WEIGHTS																	
	036		048		060		072		090/191		101/102		120/121		150		180	
	lb	kg	lb	kg	lb	kg	lb	kg	lb	kg	lb	kg	lb	kg	lb	kg	lb	kg
Power Exhaust – vertical	50	23	50	23	50	23	50	23	75	34	75	34	75	34	75	34	85	39
Power Exhaust – horizontal	30	14	30	14	30	14	30	14	30	14	30	14	30	14	30	14	75	34
Economizer	50	23	50	23	50	23	50	23	75	34	75	34	75	34	75	34	115	52
Two Position damper	39	18	39	18	39	18	39	18	58	26	58	26	58	26	58	26	65	29
Manual Dampers	12	5	12	5	12	5	12	5	18	8	18	8	18	8	18	8	25	11
Medium Gas Heat	12	5	9	4	9	4	9	4	15	7	15	7	18	8	18	8	28	13
High Gas Heat	–	–	17	8	17	8	17	8	29	13	29	13	35	16	35	16	50	23
Hail Guard (louvered)	16	7	16	7	16	7	16	7	34	15	34	15	34	15	34	15	45	20
Cu/Cu Condenser Coil ¹	6	3	13	6	13	6	15	7	12	5	23	10	23	10	23	10	190	86
Cu/Cu Condenser and Evap. Coils ¹	12	5	19	9	21	10	26	12	25	11	49	22	49	22	49	22	280	127
Roof Curb (14–in. curb)	115	52	115	52	115	52	115	52	143	65	143	65	143	65	143	65	180	82
Roof Curb (24–in. curb)	197	89	197	89	197	89	197	89	245	111	245	111	245	111	245	111	255	116
CO ₂ sensor	5	2	5	2	5	2	5	2	5	2	5	2	5	2	5	2	5	2
Flue Discharge Deflector	7	3	7	3	7	3	7	3	7	3	7	3	7	3	7	3	7	3
Optional Indoor Motor/Drive	10	5	10	5	10	5	10	5	15	7	15	7	15	7	15	7	45	20
Motor Master Controller	35	16	35	16	35	16	35	16	35	16	35	16	35	16	40	18	40	18
Supply Smoke Detector	5	2	5	2	5	2	5	2	5	2	5	2	5	2	5	2	5	2
Non–Fused Disconnect	15	7	15	7	15	7	15	7	15	7	15	7	15	7	15	7	15	7
Non–Powered Convenience outlet	5	2	5	2	5	2	5	2	5	2	5	2	5	2	5	2	5	2
Enthalpy Sensor	2	1	2	1	2	1	2	1	2	1	2	1	2	1	2	1	2	1
Differential Enthalpy Sensor	3	1	3	1	3	1	3	1	3	1	3	1	3	1	3	1	3	1

NOTE: Where multiple variations are available, the heaviest combination is listed.

¹ Where available.

APPLICATION DATA

Min operating ambient temp (cooling):

In mechanical cooling mode, your rooftop can safely operate down to an outdoor ambient temperature of 25°F (-4°C), with an accessory winter start kit; 40°F (4°C) standard min operating temperature. It is possible to provide cooling at lower outdoor ambient temperatures by using less outside air, economizers, and/or accessory low ambient kits.

Max operating ambient temp (cooling):

The maximum operating ambient temperature for cooling mode is 115°F (46°C). While cooling operation above 115°F (46°C) may be possible, it could cause either a reduction in performance, reliability, or a protective action by the unit's internal safety devices.

Min mixed air temp (heating):

Using the factory settings, the minimum temperatures for the mixed air (the combined temperature of the warm return air and the cold outdoor air) entering the dimpled, gas heat exchangers are:

<u>Aluminized</u>	<u>Stainless Steel</u>
50°F (10°C) continuous	40°F (4°C) continuous
45°F (7°C) intermittent	35°F (2°C) intermittent

Operating at lower mixed-air temperatures may be possible, if a field-supplied, outdoor air thermostat initiates both heat stages when the temperature is less than the minimum temperatures listed above. Please contact your local representative for assistance.

Min and max airflow (heating and cooling):

To maintain safe and reliable operation of your rooftop, operate within the heating airflow limits during heating mode and cooling airflow limits during cooling mode. Operating above the max may cause blow-off, undesired airflow noise, or airflow related problems with the rooftop unit. Operating below the min may cause problems with coil freeze-up and unsafe heating operation. Heating and cooling limitations differ when evaluating operating CFM, the minimum value is the HIGHER of the cooling and heating minimum CFM values published in Table 7 and the maximum value is the LOWER of the cooling and heating minimum values published in Table 7.

Heating-to-cooling changeover:

Your unit will automatically change from heating to cooling mode when using a thermostat with an auto-change-over feature.

Airflow:

All units are draw-through in cooling mode and blow-through in heating mode.

Outdoor air application strategies:

Economizers reduce operating expenses and compressor run time by providing a free source of cooling and a means of ventilation to match application changing needs. In fact, they should be considered for most applications. Also, consider the various economizer control methods and their benefits, as well as sensors required to accomplish your application goals. Please contact your local sales representative for assistance.

Motor limits, break horsepower (BHP):

Due to the internal unit design, air path, and specially designed motors, the full horsepower (maximum continuous BHP) band, as listed in Table 8, 10, and 11, can be used with the utmost confidence. There is no need for extra safety factors, the motors are designed and rigorously tested to use the entire, listed BHP

range without either nuisance tripping or premature motor failure.

Propane heating:

Liquid propane (LP) has different physical qualities than natural gas. As a result, LP requires different fuel to air mixture. To optimize the fuel/air mixture for LP, different burner orifices in an easy to install accessory kits are available from your dealer. To select the correct burner orifices or determine the heat capacity for an LP application the selection software, or the unit's service manual.

High altitude heating:

High altitudes have less oxygen, which affects the fuel/air mixture in heat exchangers. In order to maintain a proper fuel/air mixture, heat exchangers operating in altitudes above 2000 ft (610m) require different orifices. To select the correct burner orifices or determine the heat capacity for a high altitude application either the selection software, or the unit's service manual.

High altitudes have less oxygen, which means heat exchangers need less fuel. The new gas orifices in this field-installed kit make the necessary adjustment for high altitude applications. They restore the optimal fuel to air mixture and maintain healthy combustion on altitudes above 2000 ft (610m).

NOTE: Typical natural gas heating value ranges from 975 to 1050 Btu/ft³ at sea level nationally. The heating value goes down approximately 1.7% per every thousand feet elevation. Standard factory orifices can typically be used up to 2000 ft (610m) elevation without any operational issues.

Sizing a rooftop

Bigger isn't necessarily better. While an air conditioner needs to have enough capacity to meet the design loads, it doesn't need excess capacity. In fact, excess capacity typically results in very poor partload performance and humidity control.

Using higher design temperatures than ASHRAE recommends for your location, adding "safety factors" to the calculated load, are all signs of oversizing air conditioners. Oversizing the air conditioner leads to short cycling (quick on-off cycles) which results in poor humidity control, reduced efficiency, higher utility bills, larger indoor temperature swings, excessive noise, and increased wear and tear on the air conditioner.

Rather than oversizing an air conditioner, engineers should "right-size" or even slightly undersize air conditioners. Correctly sizing an air conditioner controls humidity better; promotes efficiency; reduces utility bills; extends equipment life, and maintains even, comfortable temperatures. Please contact your local representative for assistance.

Low ambient applications

The optional economizer can adequately cool your space by bringing in fresh, cool outside air. In fact, when so equipped, accessory low-ambient kit may not be necessary. In low ambient conditions, unless the outdoor air is excessively humid or contaminated, economizer-based "free cooling" is the preferred less costly and energy conscious method.

In low ambient applications where outside air might not be desired (such as contaminated or excessively humid outdoor environments), your rooftop can operate to ambient temperatures down to -20°F (-29°C) using the recommended accessory Motormaster low ambient controller.

SELECTION PROCEDURE (WITH RGS072 EXAMPLE)¹

I. Determine cooling and heating loads.

Given:

Mixed air drybulb	80°F (27°C)
Mixed air wetbulb	67°F (19°C)
Ambient drybulb	95°F (35°C)
TC _{Load}	72.0 MBH
SHC _{Load}	54.0 MBH
Vertical supply air	2100 CFM
Heating load	85.0 MBH
External static pressure	0.67 in.wg
Electrical characteristics	230–3–60

II. Make an initial guess at cooling tons.

$$\text{Refrig. tons} = \text{TC}_{\text{Load}} / 12 \text{ MBH per ton}$$

$$\text{Refrig. tons} = 72.0 / 12 = 6.0 \text{ tons}$$

In this case, start by looking at the RGS072.

III. Look up the rooftop's TC and SHC.

Table 18 shows that, at the application's supply air CFM, mixed air and ambient temperatures, the RGS072 supplies:

$$\text{TC} = 73.7 \text{ MBH}$$

$$\text{SHC} = 54.3 \text{ MBH.}$$

IV. Calculate the building latent heat load.

$$\text{LHC}_{\text{Load}} = \text{TC}_{\text{Load}} - \text{SHC}_{\text{Load}}$$

$$\text{LHC}_{\text{Load}} = 72.0 \text{ MBH} - 54.0 \text{ MBH} = 18.0 \text{ MBH}$$

V. Calculate RTU latent heat capacity.

$$\text{LHC} = \text{TC} - \text{SHC}$$

$$\text{LHC} = 73.7 \text{ MBH} - 54.3 \text{ MBH} = 19.4 \text{ MBH}$$

VI. Compare RTU capacities to loads.^{2,3}

Compare the rooftop's SHC and LHC to the building's sensible and latent heat loads.

LEGEND

TC	— Total cooling capacity
SHC	— Sensible heat capacity
LHC	— Latent heat capacity
RPM	— Revolutions per minute
RTU	— Rooftop unit
BHP	— Break horsepower
MCA	— Min. circuit ampacity
MOCP	— Max. Over-current protection
FLA	— Full load amps
RLA	— Rated load amps

VII. Select factory options (FIOP)

Local code requires an economizer for any unit with TC less than 65.0 MBH.

VIII. Calculate the total static pressure.

$$\text{External static pressure} \quad 0.67 \text{ in. wg}$$

$$\text{Sum of FIOP / Accessory static} \quad +0.13 \text{ in. wg}$$

$$\text{Total Static Pressure} \quad 0.80 \text{ in. wg}$$

IX. Look up the indoor fan RPM & BHP.

Table 39 shows, at 2100 CFM & ESP= 0.8, RPM = 1358 & BHP = 1.52

X. Convert BHP (Step VIII) into fan motor heat.

$$\text{Fan motor heat} = 2.546^* \text{ BHP/Motor Eff.}^4$$

$$\text{Fan motor heat} = 4.9 \text{ MBH}$$

XI. Calculate RTU heating capacity.

$$\text{Building heating load} \quad 85.0 \text{ MBH}$$

$$\text{Fan motor heat} \quad -4.9 \text{ MBH}$$

$$\text{Required heating capacity} \quad 80.1 \text{ MBH}$$

XII. Select a gas heater.

Table 4 shows the heating capacities of the RGS072 = 93.0 MBH. Select the RGS072

XIII. Determine electrical requirements.

Table 63 shows the MCA and MOCP of a RGS072 (without convenience outlet) as:

$$\text{MCA} = 30.9 \text{ amps} \ \& \ \text{MOCP} = 45.0 \text{ amps}$$

$$\text{Min. disconnect size: FLA} = 30 \ \& \ \text{LRA} = 48.$$

NOTES:

1. Selection software saves time by performing many of the steps above. Contact your sales representative for assistance.
2. Unit ratings are gross capacities and do not include the effect of evaporator fan motor heat. See Step X. for determining amount of evaporator fan motor heat to subtract from total and sensible capacities to obtain net cooling and net sensible capacities.
3. Selecting a unit with a SHC slightly lower than the SHC_{Load} is often better than oversizing. Slightly lower SHC's will help control indoor humidity, and prevent temperature swings.
4. Indoor fan motor efficiency is available in Tables 51–62. Use the decimal form in the equation, eg. 80% = .8.

Table 14 – COOLING CAPACITIES 3 TONS

RGS036			AMBIENT TEMPERATURE											
			85			95			105			115		
			EAT (db)			EAT (db)			EAT (db)			EAT (db)		
			75	80	85	75	80	85	75	80	85	75	80	85
900 Cfm	EAT (wb)	58 TC	28.1	28.1	31.7	26.3	26.3	29.8	24.5	24.5	27.7	22.6	22.6	25.5
		58 SHC	24.4	28.1	31.7	22.9	26.3	29.8	21.3	24.5	27.7	19.6	22.6	25.5
		62 TC	30.3	30.3	31.0	27.8	27.8	29.8	25.1	25.1	28.4	22.6	22.6	26.5
		62 SHC	22.6	26.8	31.0	21.5	25.7	29.8	20.2	24.3	28.4	18.7	22.6	26.5
		67 TC	35.5	35.5	35.5	33.1	33.1	33.1	30.5	30.5	30.5	27.5	27.5	27.5
	67 SHC	19.5	23.7	27.9	18.5	22.7	26.9	17.4	21.6	25.8	16.2	20.4	24.6	
	72 TC	39.0	39.0	39.0	37.1	37.1	37.1	35.1	35.1	35.1	32.7	32.7	32.7	
	72 SHC	15.3	19.5	23.7	14.5	18.8	23.0	13.7	17.9	22.2	12.9	17.1	21.3	
	76 TC	-	41.4	41.4	-	39.6	39.6	-	37.6	37.6	-	35.4	35.4	
	76 SHC	-	16.0	21.0	-	15.4	20.2	-	14.6	19.3	-	13.8	18.3	
1050 Cfm	EAT (wb)	58 TC	30.2	30.2	34.2	28.4	28.4	32.2	26.5	26.5	30.0	24.5	24.5	27.7
		58 SHC	26.3	30.2	34.2	24.7	28.4	32.2	23.1	26.5	30.0	21.3	24.5	27.7
		62 TC	31.9	31.9	34.2	29.4	29.4	32.8	26.7	26.7	31.2	24.5	24.5	28.8
		62 SHC	24.6	29.4	34.2	23.4	28.1	32.8	22.0	26.6	31.2	20.3	24.5	28.8
		67 TC	36.7	36.7	36.7	34.8	34.8	34.8	32.2	32.2	32.2	29.1	29.1	29.1
	67 SHC	20.6	25.4	30.2	19.8	24.6	29.4	18.8	23.6	28.4	17.6	22.4	27.2	
	72 TC	40.1	40.1	40.1	38.2	38.2	38.2	36.1	36.1	36.1	33.7	33.7	33.7	
	72 SHC	15.7	20.5	25.3	15.0	19.8	24.6	14.2	19.0	23.8	13.4	18.2	23.0	
	76 TC	-	42.4	42.4	-	40.6	40.6	-	38.5	38.5	-	36.2	36.2	
	76 SHC	-	16.6	22.2	-	15.9	21.3	-	15.2	20.4	-	14.4	19.5	
1200 Cfm	EAT (wb)	58 TC	32.2	32.2	36.4	30.4	30.4	34.3	28.4	28.4	32.1	26.3	26.3	29.7
		58 SHC	28.0	32.2	36.4	26.4	30.4	34.3	24.7	28.4	32.1	22.8	26.3	29.7
		62 TC	33.3	33.3	37.0	30.8	30.8	35.5	28.4	28.4	33.4	26.3	26.3	30.9
		62 SHC	26.4	31.7	37.0	25.1	30.3	35.5	23.4	28.4	33.4	21.7	26.3	30.9
		67 TC	37.7	37.7	37.7	35.6	35.6	35.6	33.4	33.4	33.4	30.4	30.4	30.4
	67 SHC	21.7	27.0	32.4	20.9	26.3	31.6	20.0	25.4	30.8	18.8	24.2	29.6	
	72 TC	40.9	40.9	40.9	39.0	39.0	39.0	36.9	36.9	36.9	34.4	34.4	34.4	
	72 SHC	16.1	21.5	26.8	15.4	20.8	26.1	14.7	20.0	25.4	13.8	19.2	24.5	
	76 TC	-	43.1	43.1	-	41.3	41.3	-	39.1	39.1	-	36.8	36.8	
	76 SHC	-	17.1	23.1	-	16.4	22.3	-	15.7	21.4	-	14.9	20.5	
1350 Cfm	EAT (wb)	58 TC	-	-	-	32.1	32.1	36.3	30.0	30.0	34.0	27.9	27.9	31.5
		58 SHC	-	-	-	27.9	32.1	36.3	26.1	30.0	34.0	24.2	27.9	31.5
		62 TC	28.4	28.4	30.5	32.2	32.2	37.8	30.1	30.1	35.3	27.9	27.9	32.8
		62 SHC	17.6	24.1	30.5	26.6	32.2	37.8	24.8	30.1	35.3	23.0	27.9	32.8
		67 TC	33.2	33.2	33.2	36.4	36.4	36.4	34.1	34.1	34.1	31.5	31.5	32.0
	67 SHC	15.0	21.4	27.9	21.9	27.8	33.7	21.0	26.9	32.9	20.0	26.0	32.0	
	72 TC	37.5	37.5	37.5	39.7	39.7	39.7	37.5	37.5	37.5	35.0	35.0	35.0	
	72 SHC	11.8	18.3	24.8	15.8	21.7	27.5	15.0	20.9	26.8	14.2	20.1	26.0	
	76 TC	-	40.1	40.1	-	41.8	41.8	-	39.6	39.6	-	37.3	37.3	
	76 SHC	-	15.3	22.7	-	16.8	23.2	-	16.1	22.3	-	15.3	21.5	
1500 Cfm	EAT (wb)	58 TC	28.1	28.1	34.2	33.7	33.7	38.1	31.6	31.6	35.7	29.3	29.3	33.2
		58 SHC	21.9	28.1	34.2	29.3	33.7	38.1	27.4	31.6	35.7	25.5	29.3	33.2
		62 TC	30.3	30.3	33.8	33.7	33.7	39.6	31.6	31.6	37.1	29.4	29.4	34.5
		62 SHC	19.8	26.8	33.8	27.8	33.7	39.6	26.1	31.6	37.1	24.2	29.4	34.5
		67 TC	35.5	35.5	35.5	36.9	36.9	36.9	34.6	34.6	34.9	32.0	32.0	34.0
	67 SHC	16.7	23.7	30.7	22.8	29.2	35.7	21.9	28.4	34.9	21.0	27.5	34.0	
	72 TC	39.0	39.0	39.0	40.2	40.2	40.2	38.0	38.0	38.0	35.5	35.5	35.5	
	72 SHC	12.4	19.5	26.6	16.1	22.5	28.8	15.4	21.7	28.1	14.6	21.0	27.4	
	76 TC	-	41.4	41.4	-	42.2	42.2	-	40.0	40.0	-	-	-	
	76 SHC	-	16.0	24.3	-	17.2	24.0	-	16.5	23.2	-	-	-	

LEGEND:

- Do not operate
- Cfm - Cubic feet per minute (supply air)
- EAT(db) - Entering air temperature (dry bulb)
- EAT(wb) - Entering air temperature (wet bulb)
- SHC - Sensible heat capacity
- TC - Total cooling capacity

Table 15 – COOLING CAPACITIES 4 TONS

RGS048			AMBIENT TEMPERATURE											
			85			95			105			115		
			EAT (db)			EAT (db)			EAT (db)			EAT (db)		
			75	80	85	75	80	85	75	80	85	75	80	85
1200 Cfm	EAT (wb)	58 TC	-	-	-	-	-	-	36.1	36.1	40.7	34.3	34.3	38.6
		58 SHC	-	-	-	-	-	-	31.5	36.1	40.7	29.9	34.3	38.6
		62 TC	43.1	43.1	43.1	40.8	40.8	40.8	38.4	38.4	39.4	35.9	35.9	38.2
		62 SHC	31.2	36.4	41.7	30.1	35.3	40.6	28.9	34.1	39.4	27.8	33.0	38.2
		67 TC	47.4	47.4	47.4	45.2	45.2	45.2	42.9	42.9	42.9	40.3	40.3	40.3
	67 SHC	25.9	31.2	36.4	25.0	30.2	35.5	23.9	29.2	34.4	22.9	28.2	33.4	
	72 TC	51.1	51.1	51.1	49.1	49.1	49.1	46.8	46.8	46.8	43.9	43.9	43.9	
	72 SHC	20.1	25.5	30.9	19.4	24.7	30.1	18.4	23.7	29.0	17.4	22.7	28.0	
	76 TC	-	53.3	53.3	-	51.5	51.5	-	49.2	49.2	-	45.9	45.9	
	76 SHC	-	20.8	27.4	-	20.2	26.8	-	19.3	25.7	-	18.3	24.6	
1400 cfm	EAT (wb)	58 TC	41.9	41.9	47.3	40.1	40.1	45.3	38.2	38.2	43.2	36.3	36.3	41.0
		58 SHC	36.6	41.9	47.3	35.0	40.1	45.3	33.3	38.2	43.2	31.7	36.3	41.0
		62 TC	44.6	44.6	45.4	42.3	42.3	44.2	39.8	39.8	42.9	37.3	37.3	41.6
		62 SHC	33.4	39.4	45.4	32.3	38.3	44.2	31.0	37.0	42.9	29.8	35.7	41.6
		67 TC	48.7	48.7	48.7	46.6	46.6	46.6	44.2	44.2	44.2	41.4	41.4	41.4
	67 SHC	27.3	33.2	39.2	26.4	32.3	38.3	25.3	31.3	37.3	24.2	30.2	36.2	
	72 TC	52.2	52.2	52.2	50.3	50.3	50.3	47.8	47.8	47.8	44.8	44.8	44.8	
	72 SHC	20.6	26.7	32.7	19.9	25.9	32.0	18.9	24.9	30.9	17.9	23.8	29.7	
	76 TC	-	54.1	54.1	-	52.3	52.3	-	49.9	49.9	-	46.4	46.4	
	76 SHC	-	21.5	29.0	-	20.8	28.0	-	19.9	26.9	-	18.8	25.7	
1600 Cfm	EAT (wb)	58 TC	44.0	44.0	49.6	42.1	42.1	47.4	40.1	40.1	45.2	38.1	38.1	43.0
		58 SHC	38.3	44.0	49.6	36.7	42.1	47.4	34.9	40.1	45.2	33.2	38.1	43.0
		62 TC	45.7	45.7	48.6	43.5	43.5	47.5	41.0	41.0	46.0	38.5	38.5	44.4
		62 SHC	35.3	42.0	48.6	34.2	40.8	47.5	32.9	39.4	46.0	31.6	38.0	44.4
		67 TC	49.8	49.8	49.8	47.6	47.6	47.6	45.1	45.1	45.1	42.3	42.3	42.3
	67 SHC	28.4	35.0	41.6	27.6	34.2	40.9	26.5	33.2	39.9	25.4	32.1	38.7	
	72 TC	53.0	53.0	53.0	51.1	51.1	51.1	48.6	48.6	48.6	45.4	45.4	45.4	
	72 SHC	21.0	27.6	34.3	20.3	27.0	33.6	19.4	26.0	32.6	18.3	24.8	31.3	
	76 TC	-	54.6	54.6	-	52.8	52.8	-	50.4	50.4	-	46.8	46.8	
	76 SHC	-	22.0	29.9	-	21.3	29.0	-	20.3	27.9	-	19.2	26.6	
1800 Cfm	EAT (wb)	58 TC	44.0	44.0	50.3	42.1	42.1	48.1	40.1	40.1	45.9	38.0	38.0	43.5
		58 SHC	37.6	44.0	50.3	36.0	42.1	48.1	34.3	40.1	45.9	32.6	38.0	43.5
		62 TC	45.7	45.7	49.5	43.5	43.5	48.3	41.0	41.0	46.8	38.4	38.4	45.2
		62 SHC	34.5	42.0	49.5	33.4	40.8	48.3	32.1	39.4	46.8	30.8	38.0	45.2
		67 TC	49.8	49.8	49.8	47.6	47.6	47.6	45.1	45.1	45.1	42.3	42.3	42.3
	67 SHC	27.6	35.0	42.5	26.8	34.2	41.7	25.7	33.2	40.7	24.6	32.1	39.5	
	72 TC	53.0	53.0	53.0	51.1	51.1	51.1	48.6	48.6	48.6	45.4	45.4	45.4	
	72 SHC	20.2	27.6	35.1	19.5	27.0	34.4	18.5	26.0	33.4	17.5	24.8	32.1	
	76 TC	-	54.6	54.6	-	52.8	52.8	-	50.4	50.4	-	46.8	46.8	
	76 SHC	-	22.0	30.9	-	21.3	30.0	-	20.3	28.9	-	19.2	27.5	
2000 Cfm	EAT (wb)	58 TC	46.9	46.9	52.9	45.0	45.0	50.8	42.9	42.9	48.4	40.7	40.7	45.9
		58 SHC	40.9	46.9	52.9	39.3	45.0	50.8	37.4	42.9	48.4	35.5	40.7	45.9
		62 TC	47.5	47.5	54.0	45.3	45.3	52.5	43.0	43.0	50.3	40.7	40.7	47.7
		62 SHC	38.5	46.3	54.0	37.3	44.9	52.5	35.6	43.0	50.3	33.8	40.7	47.7
		67 TC	51.2	51.2	51.2	49.1	49.1	49.1	46.5	46.5	46.5	43.5	43.5	43.5
	67 SHC	30.5	38.3	46.0	29.8	37.6	45.5	28.7	36.6	44.5	27.5	35.4	43.2	
	72 TC	54.0	54.0	54.0	52.1	52.1	52.1	49.7	49.7	49.7	46.2	46.2	46.2	
	72 SHC	21.7	29.2	36.8	21.1	28.7	36.4	20.1	27.8	35.4	18.9	26.4	33.9	
	76 TC	-	55.2	55.2	-	53.5	53.5	-	51.0	51.0	-	47.3	47.3	
	76 SHC	-	22.7	31.4	-	22.0	30.6	-	21.1	29.6	-	19.9	28.1	

LEGEND:

- Do not operate
- Cfm - Cubic feet per minute (supply air)
- EAT(db) - Entering air temperature (dry bulb)
- EAT(wb) - Entering air temperature (wet bulb)
- SHC - Sensible heat capacity
- TC - Total cooling capacity

Table 16 – COOLING CAPACITIES 5 TONS

RGS060			AMBIENT TEMPERATURE												
			85			95			105			115			
			EAT (db)			EAT (db)			EAT (db)			EAT (db)			
			75	80	85	75	80	85	75	80	85	75	80	85	
1500 Cfm	EAT (wb)	58	TC	52.9	52.9	60.0	49.9	49.9	56.6	46.6	46.6	52.9	43.1	43.1	48.9
			SHC	45.8	52.9	60.0	43.2	49.9	56.6	40.4	46.6	52.9	37.3	43.1	48.9
		62	TC	56.2	56.2	57.6	52.2	52.2	55.7	47.8	47.8	53.5	43.2	43.2	51.0
			SHC	41.8	49.7	57.6	39.9	47.8	55.7	37.8	45.6	53.5	35.5	43.2	51.0
		67	TC	62.4	62.4	62.4	58.8	58.8	58.8	54.4	54.4	54.4	49.5	49.5	49.5
	SHC	34.8	42.8	50.7	33.2	41.2	49.1	31.4	39.3	47.3	29.4	37.3	45.3		
	72	TC	68.2	68.2	68.2	64.8	64.8	64.8	60.8	60.8	60.8	56.2	56.2	56.2	
	SHC	27.2	35.2	43.2	25.9	33.9	41.9	24.4	32.4	40.4	22.6	30.6	38.6		
	76	TC	-	71.1	71.1	-	69.0	69.0	-	65.4	65.4	-	60.9	60.9	
	SHC		28.4	36.6		27.6	35.9		26.3	34.6		24.8	33.0		
1750 Cfm	EAT (wb)	58	TC	56.5	56.5	64.0	53.3	53.3	60.4	49.8	49.8	56.5	46.1	46.1	52.3
			SHC	48.9	56.5	64.0	46.1	53.3	60.4	43.1	49.8	56.5	39.9	46.1	52.3
		62	TC	58.5	58.5	63.4	54.4	54.4	61.3	49.9	49.9	58.9	46.1	46.1	54.4
			SHC	45.2	54.3	63.4	43.2	52.2	61.3	41.0	49.9	58.9	37.9	46.1	54.4
		67	TC	64.3	64.3	64.3	60.5	60.5	60.5	56.2	56.2	56.2	51.3	51.3	51.3
	SHC	36.9	46.1	55.2	35.3	44.5	53.7	33.6	42.8	51.9	31.6	40.8	49.9		
	72	TC	69.5	69.5	69.5	66.5	66.5	66.5	62.4	62.4	62.4	57.7	57.7	57.7	
	SHC	27.8	36.9	45.9	26.7	35.9	45.1	25.2	34.5	43.7	23.5	32.8	42.0		
	76	TC	-	72.2	72.2	-	70.1	70.1	-	66.6	66.6	-	-	-	
	SHC		29.3	38.9		28.6	38.2		27.4	36.8		-	-		
2000 Cfm	EAT (wb)	58	TC	59.3	59.3	67.3	56.1	56.1	63.6	52.5	52.5	59.5	48.6	48.6	55.1
			SHC	51.4	59.3	67.3	48.6	56.1	63.6	45.4	52.5	59.5	42.1	48.6	55.1
		62	TC	60.1	60.1	68.5	56.2	56.2	66.3	52.5	52.5	62.0	48.7	48.7	57.4
			SHC	48.1	58.3	68.5	46.2	56.2	66.3	43.1	52.5	62.0	39.9	48.7	57.4
		67	TC	65.7	65.7	65.7	61.9	61.9	61.9	57.5	57.5	57.5	52.6	52.6	54.4
	SHC	38.8	49.1	59.5	37.3	47.7	58.1	35.6	46.0	56.4	33.6	44.0	54.4		
	72	TC	70.1	70.1	70.1	67.6	67.6	67.6	63.6	63.6	63.6	58.9	58.9	58.9	
	SHC	28.3	38.1	48.0	27.4	37.7	48.0	26.0	36.4	46.7	24.3	34.7	45.2		
	76	TC	-	72.9	72.9	-	70.8	70.8	-	67.4	67.4	-	-	-	
	SHC		30.1	40.7		29.3	39.9		28.2	38.7		-	-		
2250 Cfm	EAT (wb)	58	TC	61.5	61.5	69.8	58.4	58.4	66.2	54.8	54.8	62.1	50.8	50.8	57.6
			SHC	53.2	61.5	69.8	50.5	58.4	66.2	47.4	54.8	62.1	43.9	50.8	57.6
		62	TC	61.6	61.6	72.6	58.4	58.4	68.9	54.8	54.8	64.6	50.8	50.8	59.9
			SHC	50.6	61.6	72.6	47.9	58.4	68.9	45.0	54.8	64.6	41.7	50.8	59.9
		67	TC	66.8	66.8	66.8	63.0	63.0	63.0	58.5	58.5	60.6	53.6	53.6	58.6
	SHC	40.5	52.0	63.4	39.1	50.7	62.3	37.4	49.0	60.6	35.5	47.0	58.6		
	72	TC	70.8	70.8	70.8	68.5	68.5	68.5	64.5	64.5	64.5	59.8	59.8	59.8	
	SHC	28.7	39.5	50.2	28.0	39.3	50.5	26.7	38.1	49.6	25.0	36.6	48.1		
	76	TC	-	73.4	73.4	-	71.2	71.2	-	67.9	67.9	-	-	-	
	SHC		30.7	42.1		30.0	41.4		28.9	40.4		-	-		
2500 Cfm	EAT (wb)	58	TC	63.3	63.3	71.8	60.1	60.1	68.2	56.5	56.5	64.1	52.6	52.6	59.6
			SHC	54.8	63.3	71.8	52.1	60.1	68.2	49.0	56.5	64.1	45.5	52.6	59.6
		62	TC	63.4	63.4	74.7	60.2	60.2	71.0	56.6	56.6	66.7	52.6	52.6	62.1
			SHC	52.0	63.4	74.7	49.4	60.2	71.0	46.5	56.6	66.7	43.2	52.6	62.1
		67	TC	67.6	67.6	67.6	63.8	63.8	66.2	59.3	59.3	64.6	54.4	54.4	62.5
	SHC	42.1	54.6	67.1	40.9	53.5	66.2	39.2	51.9	64.6	37.2	49.8	62.5		
	72	TC	71.3	71.3	71.3	69.0	69.0	69.0	65.1	65.1	65.1	60.4	60.4	60.4	
	SHC	29.1	40.7	52.2	28.5	40.7	52.9	27.3	39.7	52.2	25.7	38.3	50.9		
	76	TC	-	73.8	73.8	-	71.4	71.4	-	68.3	68.3	-	-	-	
	SHC		31.2	43.3		30.5	42.6		29.6	41.9		-	-		

LEGEND:

- Do not operate
- Cfm - Cubic feet per minute (supply air)
- EAT(db) - Entering air temperature (dry bulb)
- EAT(wb) - Entering air temperature (wet bulb)
- SHC - Sensible heat capacity
- TC - Total cooling capacity

Table 17 – COOLING CAPACITIES 6 TONS

RGS072			AMBIENT TEMPERATURE											
			85			95			105			115		
			EAT (db)			EAT (db)			EAT (db)			EAT (db)		
			75	80	85	75	80	85	75	80	85	75	80	85
1800 Cfm	EAT (wb)	58 TC	64.9	64.9	73.3	62.1	62.1	70.0	58.9	58.9	66.4	55.6	55.6	62.7
		SHC	56.6	64.9	73.3	54.1	62.1	70.0	51.4	58.9	66.4	48.5	55.6	62.7
		62 TC	68.7	68.7	70.3	64.9	64.9	68.5	60.8	60.8	66.4	56.4	56.4	64.0
		SHC	51.7	61.0	70.3	49.9	59.2	68.5	47.9	57.2	66.4	45.7	54.9	64.0
		67 TC	75.6	75.6	75.6	71.7	71.7	71.7	67.4	67.4	67.4	62.5	62.5	62.5
	SHC	42.8	52.2	61.5	41.2	50.5	59.8	39.3	48.6	58.0	37.2	46.5	55.8	
	72 TC	82.6	82.6	82.6	78.5	78.5	78.5	73.7	73.7	73.7	67.8	67.8	67.8	
	SHC	33.5	42.8	52.2	31.9	41.3	50.6	30.0	39.3	48.6	27.8	36.9	45.9	
	76 TC	-	87.5	87.5	-	83.3	83.3	-	77.7	77.7	-	70.9	70.9	
	SHC	-	35.0	44.9	-	33.5	43.4	-	31.6	41.5	-	29.3	39.1	
2100 Cfm	EAT (wb)	58 TC	68.9	68.9	77.7	65.9	65.9	74.3	62.5	62.5	70.5	58.7	58.7	66.2
		SHC	60.1	68.9	77.7	57.4	65.9	74.3	54.5	62.5	70.5	51.2	58.7	66.2
		62 TC	70.9	70.9	76.9	67.1	67.1	75.0	63.0	63.0	72.5	58.7	58.7	68.7
		SHC	55.6	66.3	76.9	53.8	64.4	75.0	51.6	62.1	72.5	48.7	58.7	68.7
		67 TC	77.8	77.8	77.8	73.7	73.7	73.7	69.2	69.2	69.2	64.0	64.0	64.0
	SHC	45.4	56.1	66.8	43.7	54.4	65.2	41.8	52.5	63.2	39.6	50.2	60.7	
	72 TC	84.5	84.5	84.5	80.3	80.3	80.3	75.1	75.1	75.1	68.8	68.8	68.8	
	SHC	34.5	45.2	55.9	32.9	43.5	54.2	30.9	41.4	52.0	28.5	38.7	48.9	
	76 TC	-	89.2	89.2	-	84.7	84.7	-	78.8	78.8	-	71.6	71.6	
	SHC	-	36.3	47.8	-	34.7	46.0	-	32.6	43.7	-	30.1	40.9	
2400 Cfm	EAT (wb)	58 TC	72.0	72.0	81.2	68.7	68.7	77.5	65.2	65.2	73.5	61.1	61.1	68.9
		SHC	62.8	72.0	81.2	60.0	68.7	77.5	56.9	65.2	73.5	53.3	61.1	68.9
		62 TC	72.8	72.8	82.8	68.9	68.9	80.7	65.2	65.2	76.4	61.2	61.2	71.6
		SHC	59.1	71.0	82.8	57.2	68.9	80.7	54.1	65.2	76.4	50.7	61.2	71.6
		67 TC	79.4	79.4	79.4	75.2	75.2	75.2	70.5	70.5	70.5	65.1	65.1	65.3
	SHC	47.7	59.8	71.8	46.0	58.1	70.2	44.0	56.0	68.1	41.6	53.5	65.3	
	72 TC	86.0	86.0	86.0	81.6	81.6	81.6	76.1	76.1	76.1	69.6	69.6	69.6	
	SHC	35.3	47.2	59.2	33.7	45.6	57.5	31.7	43.3	55.0	29.1	40.3	51.4	
	76 TC	-	90.3	90.3	-	85.7	85.7	-	79.6	79.6	-	72.1	72.1	
	SHC	-	37.3	49.8	-	35.6	48.0	-	33.5	45.6	-	30.8	42.5	
2700 Cfm	EAT (wb)	58 TC	60.3	60.3	74.1	71.1	71.1	80.2	67.4	67.4	76.0	63.0	63.0	71.1
		SHC	46.4	60.3	74.1	62.0	71.1	80.2	58.8	67.4	76.0	55.0	63.0	71.1
		62 TC	65.4	65.4	69.3	71.2	71.2	83.3	67.5	67.5	79.0	63.1	63.1	73.8
		SHC	41.0	55.1	69.3	59.0	71.2	83.3	55.9	67.5	79.0	52.3	63.1	73.8
		67 TC	72.7	72.7	72.7	76.3	76.3	76.3	71.5	71.5	72.6	65.8	65.8	69.4
	SHC	33.8	48.0	62.2	48.2	61.6	74.9	46.1	59.3	72.6	43.5	56.5	69.4	
	72 TC	79.7	79.7	79.7	82.5	82.5	82.5	76.9	76.9	76.9	70.1	70.1	70.1	
	SHC	25.8	40.2	54.6	34.5	47.5	60.5	32.3	45.0	57.7	29.7	41.7	53.8	
	76 TC	-	85.1	85.1	-	86.4	86.4	-	80.2	80.2	-	72.5	72.5	
	SHC	-	33.5	48.4	-	36.5	49.9	-	34.3	47.3	-	31.5	44.0	
3000 Cfm	EAT (wb)	58 TC	64.9	64.9	78.8	73.1	73.1	82.5	69.2	69.2	78.0	64.5	64.5	72.7
		SHC	51.1	64.9	78.8	63.8	73.1	82.5	60.3	69.2	78.0	56.2	64.5	72.7
		62 TC	68.7	68.7	76.5	73.2	73.2	85.7	69.2	69.2	81.0	64.5	64.5	75.5
		SHC	45.5	61.0	76.5	60.7	73.2	85.7	57.4	69.2	81.0	53.5	64.5	75.5
		67 TC	75.6	75.6	75.6	77.2	77.2	79.4	72.2	72.2	76.8	66.3	66.3	73.0
	SHC	36.6	52.2	67.7	50.2	64.8	79.4	48.0	62.4	76.8	45.1	59.1	73.0	
	72 TC	82.6	82.6	82.6	83.3	83.3	83.3	77.5	77.5	77.5	70.5	70.5	70.5	
	SHC	27.2	42.8	58.5	35.1	49.2	63.3	32.9	46.6	60.3	30.2	43.0	55.9	
	76 TC	-	87.5	87.5	-	86.9	86.9	-	80.6	80.6	-	72.8	72.8	
	SHC	-	35.0	51.5	-	37.3	51.6	-	35.0	48.9	-	32.1	45.3	

LEGEND:

- Do not operate in this region
- Cfm - Cubic feet per minute (supply air)
- EAT(db) - Entering air temperature (dry bulb)
- EAT(wb) - Entering air temperature (wet bulb)
- SHC - Sensible heat capacity
- TC - Total cooling capacity

Table 18 – COOLING CAPACITIES 7.5 TONS – Single Stage Cooling

RGS091			AMBIENT TEMPERATURE												
			85			95			105			115			
			EAT (db)			EAT (db)			EAT (db)			EA (db)			
			75	80	85	75	80	85	75	80	85	75	80	85	
2250 Cfm	EAT (wb)	58	TC	81.2	81.2	91.8	77.5	77.5	87.7	73.6	73.6	83.3	69.5	69.5	78.7
			SHC	70.5	81.2	91.8	67.3	77.5	87.7	63.9	73.6	83.3	60.4	69.5	78.7
		62	TC	86.9	86.9	86.9	82.3	82.3	84.0	77.2	77.2	81.5	71.9	71.9	78.8
			SHC	63.6	74.9	86.2	61.4	72.7	84.0	58.9	70.2	81.5	56.3	67.6	78.8
		67	TC	95.2	95.2	95.2	90.7	90.7	90.7	85.7	85.7	85.7	79.9	79.9	79.9
			SHC	52.8	64.2	75.6	50.9	62.2	73.6	48.8	60.1	71.5	46.3	57.6	68.9
		72	TC	103.5	103.5	103.5	98.9	98.9	98.9	93.8	93.8	93.8	87.3	87.3	87.3
			SHC	41.5	53.1	64.6	39.7	51.2	62.7	37.7	49.2	60.6	35.3	46.6	57.8
		76	TC	-	109.6	109.6	-	104.8	104.8	-	99.1	99.1	-	91.6	91.6
			SHC	-	43.7	56.0	-	42.0	54.3	-	40.0	52.4	-	37.4	49.8
2625 Cfm	EAT (wb)	58	TC	85.9	85.9	97.2	82.2	82.2	93.1	78.1	78.1	88.4	73.9	73.9	83.6
			SHC	74.6	85.9	97.2	71.4	82.2	93.1	67.9	78.1	88.4	64.1	73.9	83.6
		62	TC	89.6	89.6	94.1	85.1	85.1	91.7	80.1	80.1	89.1	74.6	74.6	86.0
			SHC	68.1	81.1	94.1	65.9	78.8	91.7	63.4	76.3	89.1	60.6	73.3	86.0
		67	TC	97.9	97.9	97.9	93.2	93.2	93.2	88.1	88.1	88.1	82.0	82.0	82.0
			SHC	55.7	68.7	81.7	53.7	66.7	79.8	51.6	64.6	77.6	49.0	62.0	74.9
		72	TC	106.0	106.0	106.0	101.3	101.3	101.3	95.9	95.9	95.9	89.0	89.0	89.0
			SHC	42.7	55.8	68.9	40.9	53.9	67.0	38.8	51.8	64.7	36.2	48.9	61.7
		76	TC	-	111.8	111.8	-	106.9	106.9	-	100.7	100.7	-	92.7	92.7
			SHC	-	45.3	59.8	-	43.6	58.0	-	41.4	55.6	-	38.7	52.6
3000 Cfm	EAT (wb)	58	TC	89.6	89.6	101.4	85.9	85.9	97.2	81.7	81.7	92.5	77.0	77.0	87.1
			SHC	77.9	89.6	101.4	74.6	85.9	97.2	71.0	81.7	92.5	66.9	77.0	87.1
		62	TC	91.8	91.8	101.1	87.2	87.2	98.6	82.3	82.3	95.5	77.1	77.1	90.6
			SHC	72.2	86.7	101.1	69.9	84.3	98.6	67.2	81.3	95.5	63.5	77.1	90.6
		67	TC	99.9	99.9	99.9	95.2	95.2	95.2	89.9	89.9	89.9	83.6	83.6	83.6
			SHC	58.3	72.9	87.5	56.4	71.0	85.5	54.2	68.8	83.4	51.6	66.1	80.5
		72	TC	107.9	107.9	107.9	103.0	103.0	103.0	97.3	97.3	97.3	90.1	90.1	90.1
			SHC	43.7	58.3	72.8	41.9	56.4	70.9	39.7	54.1	68.4	37.0	51.0	65.0
		76	TC	-	113.8	113.8	-	108.4	108.4	-	102.0	102.0	-	93.4	93.4
			SHC	-	46.7	62.5	-	44.8	60.4	-	42.6	57.9	-	39.6	54.7
3375 Cfm	EAT (wb)	58	TC	92.7	92.7	104.9	88.8	88.8	100.5	84.6	84.6	95.7	79.6	79.6	90.0
			SHC	80.5	92.7	104.9	77.1	88.8	100.5	73.4	84.6	95.7	69.1	79.6	90.0
		62	TC	93.7	93.7	107.3	89.1	89.1	104.7	84.6	84.6	99.5	79.6	79.6	93.6
			SHC	75.8	91.6	107.3	73.5	89.1	104.7	69.8	84.6	99.5	65.6	79.6	93.6
		67	TC	101.5	101.5	101.5	96.7	96.7	96.7	91.3	91.3	91.3	84.8	84.8	85.7
			SHC	60.8	76.9	93.0	58.8	74.9	91.0	56.7	72.8	88.9	53.9	69.8	85.7
		72	TC	109.4	109.4	109.4	104.3	104.3	104.3	98.4	98.4	98.4	90.9	90.9	90.9
			SHC	44.6	60.5	76.4	42.8	58.6	74.4	40.5	56.2	71.8	37.7	52.8	68.0
		76	TC	-	115.1	115.1	-	109.5	109.5	-	102.8	102.8	-	94.0	94.0
			SHC	-	47.8	64.9	-	45.9	62.7	-	43.5	60.1	-	40.4	56.5
3750 Cfm	EAT (wb)	58	TC	95.3	95.3	107.8	91.3	91.3	103.3	86.9	86.9	98.3	81.7	81.7	92.4
			SHC	82.7	95.3	107.8	79.3	91.3	103.3	75.5	86.9	98.3	70.9	81.7	92.4
		62	TC	95.5	95.5	112.2	91.3	91.3	107.4	87.0	87.0	102.2	81.7	81.7	96.0
			SHC	78.7	95.5	112.2	75.3	91.3	107.4	71.7	87.0	102.2	67.4	81.7	96.0
		67	TC	102.8	102.8	102.8	97.9	97.9	97.9	92.3	92.3	94.0	85.7	85.7	90.5
			SHC	63.1	80.6	98.2	61.2	78.7	96.3	59.0	76.5	94.0	56.0	73.2	90.5
		72	TC	110.6	110.6	110.6	105.4	105.4	105.4	99.2	99.2	99.2	91.5	91.5	91.5
			SHC	45.5	62.7	79.9	43.5	60.7	77.8	41.3	58.1	75.0	38.3	54.5	70.7
		76	TC	-	116.1	116.1	-	110.3	110.3	-	103.5	103.5	-	94.5	94.5
			SHC	-	48.9	67.0	-	46.8	64.8	-	44.4	62.0	-	41.1	58.1

LEGEND:

- Do not operate in this region
- Cfm - Cubic feet per minute (supply air)
- EAT(db) - Entering air temperature (dry bulb)
- EAT(wb) - Entering air temperature (wet bulb)
- SHC - Sensible heat capacity
- TC - Total cooling capacity

Table 19 – COOLING CAPACITIES 7.5 TONS – Two Stage Cooling

RGS090				AMBIENT TEMPERATURE											
				85			95			105			115		
				EAT (db)			EAT (db)			EAT (db)			EA (db)		
				75	80	85	75	80	85	75	80	85	75	80	85
2250 Cfm	EAT (wb)	58	TC	77.4	77.4	87.8	73.8	73.8	83.8	70.1	70.1	79.5	66.0	66.0	74.9
			SHC	66.9	77.4	87.8	63.9	73.8	83.8	60.6	70.1	79.5	57.1	66.0	74.9
		62	TC	82.2	82.2	83.9	77.5	77.5	81.7	72.6	72.6	79.2	67.3	67.3	76.4
			SHC	60.8	72.4	83.9	58.6	70.1	81.7	56.3	67.7	79.2	53.6	65.0	76.4
		67	TC	90.1	90.1	90.1	86.0	86.0	86.0	81.4	81.4	81.4	75.9	75.9	75.9
			SHC	50.2	61.8	73.3	48.5	60.1	71.6	46.5	58.1	69.7	44.2	55.8	67.4
		72	TC	98.0	98.0	98.0	94.0	94.0	94.0	89.5	89.5	89.5	84.3	84.3	84.3
			SHC	39.1	50.7	62.4	37.5	49.2	60.9	35.8	47.5	59.2	33.8	45.5	57.2
		76	TC	-	104.3	104.3	-	100.4	100.4	-	95.9	95.9	-	90.7	90.7
			SHC	-	41.7	54.0	-	40.3	52.7	-	38.7	51.0	-	36.8	49.0
2625 Cfm	EAT (wb)	58	TC	82.1	82.1	93.2	78.4	78.4	89.0	74.4	74.4	84.4	70.0	70.0	79.5
			SHC	71.0	82.1	93.2	67.8	78.4	89.0	64.3	74.4	84.4	60.6	70.0	79.5
		62	TC	84.9	84.9	91.8	80.4	80.4	89.5	75.4	75.4	86.7	70.2	70.2	82.9
			SHC	65.4	78.6	91.8	63.2	76.3	89.5	60.6	73.7	86.7	57.6	70.2	82.9
		67	TC	92.5	92.5	92.5	88.3	88.3	88.3	83.6	83.6	83.6	78.3	78.3	78.3
			SHC	53.0	66.3	79.5	51.3	64.6	78.0	49.4	62.8	76.1	47.2	60.6	73.9
		72	TC	100.4	100.4	100.4	96.4	96.4	96.4	91.7	91.7	91.7	86.4	86.4	86.4
			SHC	40.2	53.5	66.7	38.7	52.0	65.3	36.9	50.3	63.7	35.0	48.4	61.8
		76	TC	-	106.5	106.5	-	102.6	102.6	-	98.0	98.0	-	92.7	92.7
			SHC	-	43.3	57.6	-	41.8	55.9	-	40.2	54.1	-	38.4	52.2
3000 Cfm	EAT (wb)	58	TC	85.7	85.7	97.3	82.2	82.2	93.3	78.0	78.0	88.6	73.5	73.5	83.4
			SHC	74.1	85.7	97.3	71.1	82.2	93.3	67.5	78.0	88.6	63.6	73.5	83.4
		62	TC	86.9	86.9	98.7	82.8	82.8	96.4	78.2	78.2	92.3	73.6	73.6	86.9
			SHC	69.3	84.0	98.7	67.2	81.8	96.4	64.1	78.2	92.3	60.3	73.6	86.9
		67	TC	94.3	94.3	94.3	90.1	90.1	90.1	85.2	85.2	85.2	79.8	79.8	80.1
			SHC	55.6	70.5	85.4	54.0	68.9	83.9	52.1	67.1	82.2	49.9	65.0	80.1
		72	TC	102.2	102.2	102.2	98.1	98.1	98.1	93.3	93.3	93.3	87.9	87.9	87.9
			SHC	41.2	56.0	70.7	39.7	54.6	69.5	38.0	53.0	68.0	36.0	51.1	66.2
		76	TC	-	108.1	108.1	-	104.2	104.2	-	99.5	99.5	-	94.2	94.2
			SHC	-	44.5	60.2	-	43.2	58.7	-	41.6	57.0	-	39.8	55.2
3375 Cfm	EAT (wb)	58	TC	88.5	88.5	100.4	85.0	85.0	96.4	81.0	81.0	92	76.5	76.5	86.8
			SHC	76.5	88.5	100.4	73.5	85.0	96.4	70.1	81.0	92	66.1	76.5	86.8
		62	TC	88.9	88.9	103.9	85.1	85.1	100.4	81.1	81.1	95.7	76.5	76.5	90.3
			SHC	72.3	88.1	103.9	69.7	85.1	100.4	66.5	81.1	95.7	62.7	76.5	90.3
		67	TC	95.8	95.8	95.8	91.5	91.5	91.5	86.6	86.6	87.9	81.1	81.1	85.8
			SHC	58.0	74.4	90.9	56.4	73.0	89.6	54.6	71.3	87.9	52.4	69.1	85.8
		72	TC	103.6	103.6	103.6	99.4	99.4	99.4	94.6	94.6	94.6	89.1	89.1	89.1
			SHC	42.0	58.3	74.5	40.6	57.0	73.4	38.9	55.5	72.0	37.0	53.7	70.3
		76	TC	-	109.2	109.2	-	105.4	105.4	-	100.7	100.7	-	95.3	95.3
			SHC	-	45.6	62.6	-	44.4	61.3	-	42.8	59.7	-	41.0	58.0
3750 Cfm	EAT (wb)	58	TC	90.8	90.8	103.0	87.3	87.3	99.1	83.3	83.3	94.5	78.8	78.8	89.4
			SHC	78.5	90.8	103.0	75.5	87.3	99.1	72.0	83.3	94.5	68.2	78.8	89.4
		62	TC	90.9	90.9	107.2	87.4	87.4	103.1	83.3	83.3	98.4	78.9	78.9	93.1
			SHC	74.5	90.9	107.2	71.6	87.4	103.1	68.3	83.3	98.4	64.7	78.9	93.1
		67	TC	97.0	97.0	97.0	92.6	92.6	95.1	87.6	87.6	93.4	82.1	82.1	91.2
			SHC	60.3	78.2	96.2	58.8	76.9	95.1	56.9	75.2	93.4	54.8	73.0	91.2
		72	TC	104.7	104.7	104.7	100.5	100.5	100.5	95.6	95.6	95.6	90.1	90.1	90.1
			SHC	42.9	60.5	78.1	41.4	59.3	77.1	39.8	57.8	75.9	37.9	56.1	74.3
		76	TC	-	110.2	110.2	-	106.2	106.2	-	101.6	101.6	-	96.1	96.1
			SHC	-	46.7	64.8	-	45.4	63.6	-	44.0	62.3	-	42.2	60.6

LEGEND:

- Do not operate in this region
- Cfm – Cubic feet per minute (supply air)
- EAT(db) – Entering air temperature (dry bulb)
- EAT(wb) – Entering air temperature (wet bulb)
- SHC – Sensible heat capacity
- TC – Total capacity

Table 20 – COOLING CAPACITIES 8.5 TONS – Single Stage Cooling

RGS101			AMBIENT TEMPERATURE												
			85			95			105			115			
			EAT (db)			EAT (db)			EAT (db)			EAT (db)			
			75	80	85	75	80	85	75	80	85	75	80	85	
2550 Cfm	EAT (wb)	58	TC	88.1	88.1	99.9	84.1	84.1	95.3	79.6	79.6	90.3	74.9	74.9	84.9
			SHC	76.4	88.1	99.9	72.8	84.1	95.3	69.0	79.6	90.3	64.9	74.9	84.9
		62	TC	93.9	93.9	95.2	88.6	88.6	92.6	82.8	82.8	89.7	76.6	76.6	86.5
			SHC	69.4	82.3	95.2	66.8	79.7	92.6	64.1	76.9	89.7	61.0	73.8	86.5
		67	TC	103.8	103.8	103.8	98.7	98.7	98.7	93.0	93.0	93.0	86.7	86.7	86.7
		SHC	57.8	70.7	83.6	55.6	68.5	81.4	53.1	66.1	79.0	50.5	63.4	76.4	
	72	TC	113.1	113.1	113.1	108.0	108.0	108.0	102.4	102.4	102.4	96.1	96.1	96.1	
		SHC	45.2	58.3	71.3	43.2	56.3	69.3	41.1	54.1	67.1	38.7	51.7	64.7	
	76	TC	-	119.9	119.9	-	114.7	114.7	-	109.0	109.0	-	102.7	102.7	
		SHC	-	47.9	61.9	-	46.0	60.1	-	44.1	58.1	-	41.9	55.8	
2975 Cfm	EAT (wb)	58	TC	93.6	93.6	106.1	89.3	89.3	101.2	84.6	84.6	96.0	79.6	79.6	90.3
			SHC	81.1	93.6	106.1	77.4	89.3	101.2	73.3	84.6	96.0	69.0	79.6	90.3
		62	TC	97.5	97.5	104.3	92.0	92.0	101.4	86.1	86.1	98.3	79.8	79.8	94.1
			SHC	74.7	89.5	104.3	72.0	86.7	101.4	69.1	83.7	98.3	65.6	79.8	94.1
		67	TC	106.7	106.7	106.7	101.5	101.5	101.5	95.7	95.7	95.7	89.2	89.2	89.2
		SHC	61.0	75.8	90.6	58.8	73.6	88.5	56.4	71.3	86.1	53.8	68.7	83.6	
	72	TC	115.8	115.8	115.8	110.6	110.6	110.6	104.9	104.9	104.9	98.4	98.4	98.4	
		SHC	46.5	61.3	76.2	44.5	59.4	74.2	42.3	57.2	72.1	40.0	54.8	69.7	
	76	TC	-	122.4	122.4	-	117.0	117.0	-	111.1	111.1	-	104.5	104.5	
		SHC	-	49.8	66.1	-	47.8	63.9	-	45.7	61.6	-	43.4	59.0	
3400 Cfm	EAT (wb)	58	TC	98.1	98.1	111.3	93.7	93.7	106.2	88.9	88.9	100.8	83.7	83.7	94.9
			SHC	85.0	98.1	111.3	81.2	93.7	106.2	77.0	88.9	100.8	72.5	83.7	94.9
		62	TC	100.0	100.0	112.3	94.9	94.9	108.6	89.1	89.1	104.9	83.8	83.8	98.7
			SHC	79.3	95.8	112.3	76.3	92.5	108.6	73.2	89.1	104.9	68.8	83.8	98.7
		67	TC	109.0	109.0	109.0	103.6	103.6	103.6	97.6	97.6	97.6	91.0	91.0	91.0
		SHC	63.9	80.5	97.2	61.8	78.5	95.2	59.4	76.1	92.9	56.8	73.5	90.3	
	72	TC	117.9	117.9	117.9	112.5	112.5	112.5	106.6	106.6	106.6	100.0	100.0	100.0	
		SHC	47.6	64.1	80.6	45.6	62.1	78.7	43.4	60.0	76.6	41.1	57.6	74.2	
	76	TC	-	124.2	124.2	-	118.6	118.6	-	112.5	112.5	-	105.7	105.7	
		SHC	-	51.2	69.0	-	49.2	66.7	-	47.0	64.4	-	44.7	61.9	
3825 Cfm	EAT (wb)	58	TC	101.6	101.6	115.1	97.2	97.2	110.1	92.3	92.3	104.6	87.0	87.0	98.6
			SHC	88.0	101.6	115.1	84.2	97.2	110.1	80.0	92.3	104.6	75.4	87.0	98.6
		62	TC	101.9	101.9	120.0	97.3	97.3	114.6	92.4	92.4	108.9	87.1	87.1	102.6
			SHC	83.7	101.8	120.0	79.9	97.3	114.6	75.9	92.4	108.9	71.6	87.1	102.6
		67	TC	110.7	110.7	110.7	105.3	105.3	105.3	99.2	99.2	99.2	92.5	92.5	96.7
		SHC	66.7	85.0	103.4	64.6	83.0	101.5	62.2	80.8	99.3	59.6	78.2	96.7	
	72	TC	119.4	119.4	119.4	114.0	114.0	114.0	108.0	108.0	108.0	101.3	101.3	101.3	
		SHC	48.5	66.6	84.6	46.6	64.7	82.7	44.4	62.6	80.7	42.1	60.2	78.4	
	76	TC	-	125.5	125.5	-	119.8	119.8	-	113.6	113.6	-	106.7	106.7	
		SHC	-	52.4	71.5	-	50.4	69.3	-	48.2	67.0	-	45.9	64.4	
4250 Cfm	EAT (wb)	58	TC	104.4	104.4	118.3	99.9	99.9	113.2	95.0	95.0	107.6	89.5	89.5	101.5
			SHC	90.4	104.4	118.3	86.6	99.9	113.2	82.3	95.0	107.6	77.6	89.5	101.5
		62	TC	104.4	104.4	123.0	99.9	99.9	117.8	95.0	95.0	112.0	89.6	89.6	105.6
			SHC	85.8	104.4	123.0	82.1	99.9	117.8	78.1	95.0	112.0	73.6	89.6	105.6
		67	TC	112.1	112.1	112.1	106.6	106.6	107.5	100.4	100.4	105.3	93.6	93.6	102.7
		SHC	69.2	89.2	109.2	67.2	87.3	107.5	64.9	85.1	105.3	62.3	82.5	102.7	
	72	TC	120.7	120.7	120.7	115.1	115.1	115.1	109.0	109.0	109.0	102.2	102.2	102.2	
		SHC	49.4	68.9	88.4	47.4	67.0	86.5	45.3	64.9	84.6	42.9	62.6	82.3	
	76	TC	-	126.6	126.6	-	120.8	120.8	-	114.5	114.5	-	107.4	107.4	
		SHC	-	53.5	73.9	-	51.5	71.7	-	49.3	69.4	-	46.9	66.8	

LEGEND:

- Do not operate in this region
- Cfm - Cubic feet per minute (supply air)
- EAT(db) - Entering air temperature (dry bulb)
- EAT(wb) - Entering air temperature (wet bulb)
- SHC - Sensible heat capacity
- TC - Total cooling capacity

Table 21 – COOLING CAPACITIES 8.5 TONS – Two Stage Cooling

RGS102				AMBIENT TEMPERATURE												
				85			95			105			115			
				EA (dB)			EA (dB)			EA (dB)			EA (dB)			
				75	80	85	75	80	85	75	80	85	75	80	85	
2550 Cfm	EAT (wb)	58	TC	89.7	89.7	101.6	85.2	85.2	96.5	79.6	79.6	90.1	73.8	73.8	83.6	
			SHC	77.8	89.7	101.6	73.9	85.2	96.5	69.0	79.6	90.1	64.0	73.8	83.6	
		62	TC	94.3	94.3	97.9	88.7	88.7	95.2	81.3	81.3	91.5	74.3	74.3	86.5	
			SHC	71.0	84.4	97.9	68.2	81.7	95.2	64.7	78.1	91.5	60.6	73.6	86.5	
		67	TC	105.0	105.0	105.0	99.3	99.3	99.3	92.2	92.2	92.2	84.1	84.1	84.1	
			SHC	59.0	72.6	86.1	56.6	70.1	83.7	53.6	67.1	80.7	50.3	63.8	77.3	
	72	TC	115.9	115.9	115.9	110.4	110.4	110.4	104.2	104.2	104.2	96.0	96.0	96.0		
		SHC	46.4	60.0	73.6	44.3	57.9	71.5	41.9	55.5	69.1	38.8	52.4	65.9		
	76	TC	-	123.7	123.7	-	118.3	118.3	-	112.4	112.4	-	105.7	105.7		
		SHC	-	49.3	63.3	-	47.3	61.4	-	45.3	59.3	-	42.9	56.7		
	2975 Cfm	EAT (wb)	58	TC	95.3	95.3	107.9	90.7	90.7	102.7	84.8	84.8	96.1	78.7	78.7	89.1
				SHC	82.6	95.3	107.9	78.6	90.7	102.7	73.5	84.8	96.1	68.2	78.7	89.1
62			TC	97.9	97.9	107.8	92.1	92.1	104.7	85.4	85.4	99.4	78.8	78.8	92.8	
			SHC	76.7	92.2	107.8	73.9	89.3	104.7	69.6	84.5	99.4	64.8	78.8	92.8	
67			TC	108.5	108.5	108.5	102.6	102.6	102.6	95.4	95.4	95.4	86.9	86.9	86.9	
			SHC	62.8	78.4	94.1	60.4	76.0	91.7	57.4	73.1	88.8	54.0	69.7	85.3	
72		TC	119.1	119.1	119.1	113.5	113.5	113.5	107.2	107.2	107.2	99.2	99.2	99.2		
		SHC	47.9	63.5	79.2	45.8	61.5	77.1	43.5	59.2	74.9	40.6	56.3	72.0		
76		TC	-	126.4	126.4	-	120.8	120.8	-	114.8	114.8	-	108.2	108.2		
		SHC	-	51.1	67.4	-	49.2	65.3	-	47.0	63.0	-	44.8	60.7		
3400 Cfm		EAT (wb)	58	TC	100.0	100.0	113.3	95.2	95.2	107.9	89.3	89.3	101.1	82.9	82.9	93.9
				SHC	86.7	100.0	113.3	82.6	95.2	107.9	77.4	89.3	101.1	71.8	82.9	93.9
	62		TC	101.1	101.1	115.8	95.7	95.7	111.7	89.4	89.4	105.3	83.0	83.0	97.7	
			SHC	81.5	98.7	115.8	78.2	94.9	111.7	73.5	89.4	105.3	68.2	83.0	97.7	
	67		TC	111.1	111.1	111.1	105.1	105.1	105.1	97.8	97.8	97.8	89.1	89.1	93.0	
			SHC	66.2	83.9	101.6	63.9	81.6	99.3	61.0	78.7	96.5	57.5	75.3	93.0	
	72	TC	121.3	121.3	121.3	115.6	115.6	115.6	109.4	109.4	109.4	101.5	101.5	101.5		
		SHC	49.2	66.7	84.3	47.1	64.7	82.3	44.9	62.5	80.2	42.1	59.9	77.7		
	76	TC	-	128.3	128.3	-	122.6	122.6	-	116.3	116.3	-	109.7	109.7		
		SHC	-	52.7	70.7	-	50.7	68.6	-	48.6	66.4	-	46.4	64.2		
	3825 Cfm	EAT (wb)	58	TC	104.0	104.0	117.8	99.1	99.1	112.3	93.2	93.2	105.5	86.5	86.5	97.9
				SHC	90.2	104.0	117.8	86.0	99.1	112.3	80.8	93.2	105.5	75.0	86.5	97.9
62			TC	104.2	104.2	122.7	99.3	99.3	116.9	93.3	93.3	109.8	86.6	86.6	101.9	
			SHC	85.7	104.2	122.7	81.7	99.3	116.9	76.7	93.3	109.8	71.2	86.6	101.9	
67			TC	113.1	113.1	113.1	107.1	107.1	107.1	99.9	99.9	103.8	91.0	91.0	100.3	
			SHC	69.4	89.1	108.8	67.1	86.8	106.5	64.3	84.1	103.8	60.9	80.6	100.3	
72		TC	123.0	123.0	123.0	117.2	117.2	117.2	110.9	110.9	110.9	103.3	103.3	103.3		
		SHC	50.3	69.7	89.0	48.3	67.7	87.1	46.1	65.6	85.2	43.5	63.3	83.0		
76		TC	-	129.7	129.7	-	124.0	124.0	-	117.5	117.5	-	110.8	110.8		
		SHC	-	54.0	73.7	-	52.1	71.7	-	50.0	69.5	-	47.8	67.4		
4250 Cfm		EAT (wb)	58	TC	107.4	107.4	121.7	102.5	102.5	116.1	96.5	96.5	109.3	89.5	89.5	101.4
				SHC	93.1	107.4	121.7	88.9	102.5	116.1	83.7	96.5	109.3	77.6	89.5	101.4
	62		TC	107.5	107.5	126.6	102.6	102.6	120.8	96.6	96.6	113.7	89.6	89.6	105.5	
			SHC	88.4	107.5	126.6	84.4	102.6	120.8	79.5	96.6	113.7	73.7	89.6	105.5	
	67		TC	114.7	114.7	115.6	108.7	108.7	113.5	101.7	101.7	110.8	92.6	92.6	107.2	
			SHC	72.5	94.0	115.6	70.2	91.8	113.5	67.5	89.2	110.8	64.0	85.6	107.2	
	72	TC	124.3	124.3	124.3	118.5	118.5	118.5	112.1	112.1	112.1	104.7	104.7	104.7		
		SHC	51.3	72.4	93.4	49.3	70.5	91.7	47.2	68.5	89.9	44.7	66.4	88.1		
	76	TC	-	130.7	130.7	-	125.0	125.0	-	118.5	118.5	-	111.6	111.6		
		SHC	-	55.3	76.5	-	53.5	74.6	-	51.3	72.4	-	49.2	70.3		

LEGEND:

- Do not operate in this region
- Cfm – Cubic feet per minute (supply air)
- EAT(db) – Entering air temperature (dry bulb)
- EAT(wb) – Entering air temperature (wet bulb)
- SHC – Sensible heat capacity
- TC – Total capacity

Table 22 – COOLING CAPACITIES 10 TONS – Single Stage Cooling

RGS121			AMBIENT TEMPERATURE											
			85			95			105			115		
			EAT (db)			EAT (db)			EAT (db)			EAT (db)		
Cfm	EAT (wb)	TC SHC	75	80	85	75	80	85	75	80	85	75	80	85
			3000	58	TC	106.3	106.3	120.5	101.7	101.7	115.2	96.6	96.6	109.4
SHC	92.2	106.3			120.5	88.2	101.7	115.2	83.8	96.6	109.4	78.9	91.0	103.1
62	TC	112.5		112.5	115.2	106.5	106.5	112.3	99.9	99.9	109.0	92.7	92.7	105.2
	SHC	83.8		99.5	115.2	81.0	96.6	112.3	77.8	93.4	109.0	74.2	89.7	105.2
67	TC	123.5		123.5	123.5	117.8	117.8	117.8	111.3	111.3	111.3	104.0	104.0	104.0
	SHC	69.2		85.0	100.7	66.8	82.5	98.3	64.1	79.8	95.5	61.0	76.8	92.5
72	TC	134.3		134.3	134.3	128.5	128.5	128.5	122.0	122.0	122.0	114.7	114.7	114.7
	SHC	53.8		69.6	85.5	51.6	67.4	83.2	49.1	64.9	80.7	46.3	62.1	77.9
76	TC	-		142.4	142.4	-	136.3	136.3	-	129.5	129.5	-	121.8	121.8
	SHC	-		56.8	73.3	-	54.7	71.2	-	52.3	68.8	-	49.7	66.2
3500	58	TC	112.9	112.9	127.8	108.0	108.0	122.3	102.7	102.7	116.3	96.8	96.8	109.7
		SHC	97.9	112.9	127.8	93.6	108.0	122.3	89.0	102.7	116.3	83.9	96.8	109.7
	62	TC	116.3	116.3	126.2	110.5	110.5	123.3	103.8	103.8	119.5	97.1	97.1	114.3
		SHC	90.2	108.2	126.2	87.4	105.3	123.3	84.0	101.8	119.5	79.8	97.1	114.3
	67	TC	126.9	126.9	126.9	120.9	120.9	120.9	114.3	114.3	114.3	106.8	106.8	106.8
		SHC	73.2	91.3	109.4	70.8	88.9	107.1	68.1	86.2	104.4	65.0	83.2	101.3
	72	TC	137.5	137.5	137.5	131.4	131.4	131.4	124.7	124.7	124.7	117.2	117.2	117.2
		SHC	55.3	73.4	91.5	53.1	71.1	89.2	50.6	68.7	86.7	47.8	65.9	83.9
	76	TC	-	145.1	145.1	-	138.8	138.8	-	131.7	131.7	-	123.6	123.6
		SHC	-	59.0	78.2	-	56.7	75.8	-	54.3	73.1	-	51.5	70.0
4000	58	TC	117.8	117.8	133.5	113.0	113.0	128.0	107.5	107.5	121.8	101.5	101.5	115.0
		SHC	102.2	117.8	133.5	98.0	113.0	128.0	93.3	107.5	121.8	88.0	101.5	115.0
	62	TC	119.1	119.1	136.0	113.5	113.5	132.5	107.7	107.7	126.7	101.6	101.6	119.6
		SHC	95.8	115.9	136.0	92.8	112.6	132.5	88.6	107.7	126.7	83.6	101.6	119.6
	67	TC	129.4	129.4	129.4	123.3	123.3	123.3	116.5	116.5	116.5	108.9	108.9	109.8
		SHC	76.9	97.3	117.7	74.5	95.0	115.4	71.8	92.3	112.8	68.8	89.3	109.8
	72	TC	139.7	139.7	139.7	133.5	133.5	133.5	126.6	126.6	126.6	118.8	118.8	118.8
		SHC	56.7	76.8	97.0	54.4	74.6	94.7	51.9	72.1	92.3	49.1	69.3	89.5
	76	TC	-	147.0	147.0	-	140.5	140.5	-	133.2	133.2	-	124.9	124.9
		SHC	-	60.6	81.7	-	58.4	79.3	-	55.8	76.5	-	53.0	73.5
4500	58	TC	121.7	121.7	137.9	116.8	116.8	132.3	111.2	111.2	126.0	105.0	105.0	118.9
		SHC	105.6	121.7	137.9	101.3	116.8	132.3	96.4	111.2	126.0	91.0	105.0	118.9
	62	TC	121.8	121.8	143.4	116.9	116.9	137.6	111.3	111.3	131.0	105.1	105.1	123.7
		SHC	100.2	121.8	143.4	96.1	116.9	137.6	91.6	111.3	131.0	86.5	105.1	123.7
	67	TC	131.3	131.3	131.3	125.1	125.1	125.1	118.2	118.2	120.8	110.5	110.5	117.7
		SHC	80.3	102.9	125.5	78.0	100.7	123.3	75.3	98.0	120.8	72.3	95.0	117.7
	72	TC	141.5	141.5	141.5	135.1	135.1	135.1	128.0	128.0	128.0	120.1	120.1	120.1
		SHC	57.9	80.0	102.1	55.6	77.7	99.9	53.1	75.2	97.4	50.3	72.4	94.6
	76	TC	-	148.3	148.3	-	141.8	141.8	-	134.3	134.3	-	125.8	125.8
		SHC	-	62.1	84.9	-	59.8	82.5	-	57.3	79.7	-	54.4	76.6
5000	58	TC	125.0	125.0	141.6	120.0	120.0	135.9	114.3	114.3	129.5	107.9	107.9	122.3
		SHC	108.4	125.0	141.6	104.0	120.0	135.9	99.1	114.3	129.5	93.6	107.9	122.3
	62	TC	125.1	125.1	147.2	120.1	120.1	141.4	114.4	114.4	134.7	108.0	108.0	127.2
		SHC	102.9	125.1	147.2	98.8	120.1	141.4	94.1	114.4	134.7	88.9	108.0	127.2
	67	TC	132.8	132.8	133.0	126.5	126.5	130.8	119.6	119.6	128.2	111.8	111.8	125.1
		SHC	83.6	108.3	133.0	81.2	106.0	130.8	78.6	103.4	128.2	75.6	100.3	125.1
	72	TC	142.8	142.8	142.8	136.3	136.3	136.3	129.1	129.1	129.1	121.1	121.1	121.1
		SHC	59.0	82.9	106.9	56.7	80.7	104.7	54.1	78.2	102.2	51.3	75.4	99.4
	76	TC	-	149.4	149.4	-	142.8	142.8	-	135.1	135.1	-	126.5	126.5
		SHC	-	63.4	87.9	-	61.2	85.5	-	58.6	82.7	-	55.6	79.4

LEGEND:

- Do not operate in this region
- Cfm - Cubic feet per minute (supply air)
- EAT(db) - Entering air temperature (dry bulb)
- EAT(wb) - Entering air temperature (wet bulb)
- SHC - Sensible heat capacity
- TC - Total cooling capacity

Table 23 – COOLING CAPACITIES 10 TONS – Two Stage Cooling

RGS120				AMBIENT TEMPERATURE											
				85			95			105			115		
				EAT (db)			EAT (db)			EAT (db)			EAT (db)		
				75	80	85	75	80	85	75	80	85	75	80	85
3000 Cfm	EAT (wb)	58	TC	107.6	107.6	121.9	102.5	102.5	116.2	96.8	96.8	109.7	90.5	90.5	102.6
			SHC	93.2	107.6	121.9	88.8	102.5	116.2	83.9	96.8	109.7	78.4	90.5	102.6
		62	TC	113.6	113.6	116.5	107.1	107.1	113.4	99.7	99.7	109.8	91.8	91.8	104.9
			SHC	84.6	100.6	116.5	81.5	97.4	113.4	78.0	93.9	109.8	73.7	89.3	104.9
		67	TC	124.4	124.4	124.4	118.4	118.4	118.4	111.5	111.5	111.5	103.3	103.3	103.3
			SHC	69.7	85.7	101.7	67.1	83.2	99.2	64.3	80.3	96.3	60.8	76.8	92.8
		72	TC	135.8	135.8	135.8	129.7	129.7	129.7	122.8	122.8	122.8	115	115	115
			SHC	54.3	70.4	86.6	52.0	68.1	84.2	49.3	65.4	81.6	46.4	62.5	78.6
		76	TC	-	145.3	145.3	-	139	139	-	131.9	131.9	-	124.1	124.1
			SHC	-	57.8	74.3	-	55.6	72.1	-	53.1	69.6	-	50.4	66.9
3500 Cfm	EAT (wb)	58	TC	114.2	114.2	129.4	108.9	108.9	123.4	102.9	102.9	116.6	96.3	96.3	109.1
			SHC	98.9	114.2	129.4	94.3	108.9	123.4	89.1	102.9	116.6	83.4	96.3	109.1
		62	TC	117.2	117.2	127.9	111.0	111.0	124.7	104.0	104.0	119.5	96.5	96.5	113.7
			SHC	91.1	109.5	127.9	88.1	106.4	124.7	83.9	101.7	119.5	79.3	96.5	113.7
		67	TC	127.8	127.8	127.8	121.7	121.7	121.7	114.5	114.5	114.5	106.6	106.6	106.6
			SHC	73.8	92.3	110.8	71.3	89.8	108.3	68.4	87.0	105.5	65.2	83.8	102.3
		72	TC	139.4	139.4	139.4	133.0	133.0	133	125.8	125.8	125.8	117.9	117.9	117.9
			SHC	56.0	74.6	93.1	53.7	72.2	90.8	51.0	69.6	88.2	48.1	66.7	85.4
		76	TC	-	148.8	148.8	-	142.2	142.2	-	134.9	134.9	-	126.8	126.8
			SHC	-	60.2	79.5	-	58.0	77.1	-	55.4	74.5	-	52.7	71.6
4000 Cfm	EAT (wb)	58	TC	119.0	119.0	134.9	114.0	114.0	129.2	108.0	108.0	122.4	101.1	101.1	114.6
			SHC	103.1	119.0	134.9	98.7	114.0	129.2	93.6	108.0	122.4	87.6	101.1	114.6
		62	TC	120.3	120.3	137.1	114.7	114.7	132.8	108.2	108.2	127.5	101.3	101.3	119.3
			SHC	96.5	116.8	137.1	93.0	112.9	132.8	88.9	108.2	127.5	83.2	101.3	119.3
		67	TC	130.5	130.5	130.5	124.1	124.1	124.1	116.8	116.8	116.8	108.7	108.7	111.1
			SHC	77.7	98.6	119.5	75.2	96.2	117.2	72.3	93.3	114.4	69.1	90.1	111.1
		72	TC	142.1	142.1	142.1	135.5	135.5	135.5	128.2	128.2	128.2	120.0	120.0	120.0
			SHC	57.6	78.4	99.3	55.2	76.1	97.1	52.5	73.6	94.6	49.7	70.7	91.8
		76	TC	-	151.4	151.4	-	144.7	144.7	-	137.1	137.1	-	-	-
			SHC	-	62.3	83.8	-	60.0	81.4	-	57.5	78.8	-	-	-
4500 Cfm	EAT (wb)	58	TC	123.0	123.0	139.5	117.8	117.8	133.6	111.9	111.9	126.9	105.3	105.3	119.3
			SHC	106.6	123.0	139.5	102.1	117.8	133.6	97.0	111.9	126.9	91.2	105.3	119.3
		62	TC	123.4	123.4	144.4	117.9	117.9	139.0	112.0	112.0	132.0	105.4	105.4	124.2
			SHC	100.9	122.7	144.4	96.9	117.9	139	92.1	112.0	132	86.6	105.4	124.2
		67	TC	132.6	132.6	132.6	126.0	126	126.0	118.7	118.7	122.9	110.4	110.4	119.6
			SHC	81.4	104.6	127.9	78.9	102.3	125.7	76.1	99.5	122.9	72.9	96.2	119.6
		72	TC	144.2	144.2	144.2	137.4	137.4	137.4	129.9	129.9	129.9	121.6	121.6	121.6
			SHC	59.0	82.1	105.2	56.6	79.8	103.1	54.0	77.3	100.7	51.1	74.5	98
		76	TC	-	153.4	153.4	-	146.6	146.6	-	138.9	138.9	-	-	-
			SHC	-	64.1	87.8	-	61.9	85.6	-	59.4	83	-	-	-
5000 Cfm	EAT (wb)	58	TC	126.5	126.5	143.3	121.2	121.2	137.4	115.1	115.1	130.5	108.4	108.4	122.8
			SHC	109.6	126.5	143.3	105.0	121.2	137.4	99.8	115.1	130.5	93.9	108.4	122.8
		62	TC	126.5	126.5	149.1	121.3	121.3	142.9	115.2	115.2	135.8	108.5	108.5	127.8
			SHC	104.0	126.5	149.1	99.7	121.3	142.9	94.7	115.2	135.8	89.1	108.5	127.8
		67	TC	134.2	134.2	135.9	127.5	127.5	133.8	120.1	120.1	131.0	111.9	111.9	127.6
			SHC	84.9	110.4	135.9	82.4	108.1	133.8	79.6	105.3	131	76.4	102.0	127.6
		72	TC	145.8	145.8	145.8	139.0	139.0	139.0	131.3	131.3	131.3	122.9	122.9	122.9
			SHC	60.3	85.6	110.8	57.9	83.4	108.9	55.3	81.0	106.6	52.5	78.2	104
		76	TC	-	155.1	155.1	-	148.2	148.2	-	-	-	-	-	-
			SHC	-	65.9	91.5	-	63.7	89.5	-	-	-	-	-	-

LEGEND:

- Do not operate in this region
- Cfm – Cubic feet per minute (supply air)
- EAT(db) – Entering air temperature (dry bulb)
- EAT(wb) – Entering air temperature (wet bulb)
- SHC – Sensible heat capacity
- TC – Total capacity

Table 24 – COOLING CAPACITIES 12.5 TONS – Two Stage Cooling

RGS150				AMBIENT TEMPERATURE											
				85			95			105			115		
				EAT (db)			EAT (db)			EAT (db)			EAT (db)		
				75	80	85	75	80	85	75	80	85	75	80	85
3600 Cfm	EAT (wb)	58	TC	127.6	127.6	142.9	121.7	121.7	137.6	115.0	115.0	130	108.3	108.3	122.6
			SHC	110.3	126.6	142.9	105.8	121.7	137.6	99.9	115.0	130	94.1	108.3	122.6
		62	TC	136.1	136.1	136.1	131.1	131.1	131.1	123.8	123.8	124.5	114.9	114.9	120.3
			SHC	96.6	112.8	129.0	94.7	111.2	127.7	91.4	108.0	124.5	87.3	103.8	120.3
		67	TC	146.2	146.2	146.2	142.0	142.0	142.0	136.2	136.2	136.2	128.8	128.8	128.8
			SHC	78.5	94.4	110.3	76.9	93.1	109.2	74.7	91.0	107.3	71.7	88.1	104.6
		72	TC	155.9	155.9	155.9	152.4	152.4	152.4	147.2	147.2	147.2	140.1	140.1	140.1
			SHC	60.1	76.6	93.2	58.7	75.2	91.7	56.8	73.3	89.7	54.2	70.6	87.0
		76	TC	-	163.0	163	-	160.0	160	-	155.1	155.1	-	148.2	148.2
			SHC	-	62.0	81.8	-	61.1	80.9	-	59.5	79.3	-	57.0	76.3
4200 Cfm	EAT (wb)	58	TC	132.2	132.2	149.5	128.2	128.2	144.9	121.9	121.9	137.8	115.0	115.0	130.1
			SHC	115.0	132.2	149.5	111.5	128.2	144.9	106.0	121.9	137.8	99.9	115.0	130.1
		62	TC	139.6	139.6	139.6	134.7	134.7	138	128.0	128.0	135.6	119.1	119.1	131.2
			SHC	102.5	120.8	139	100.8	119.4	138	98.1	116.8	135.6	93.9	112.6	131.2
		67	TC	149.5	149.5	149.5	145.4	145.4	145.4	139.6	139.6	139.6	132.1	132.1	132.1
			SHC	81.8	99.6	117.4	80.6	98.7	116.8	78.5	96.9	115.2	75.7	94.3	112.8
		72	TC	159.0	159.0	159.0	155.5	155.5	155.5	150.3	150.3	150.3	143.1	143.1	143.1
			SHC	61.4	79.6	97.8	60.2	78.5	96.8	58.3	76.7	95	55.8	74.2	92.5
		76	TC	-	165.7	165.7	-	162.8	162.8	-	157.8	157.8	-	150.8	150.8
			SHC	-	64.6	87.7	-	63.5	86.3	-	61.5	83.3	-	58.9	79.9
4800 Cfm	EAT (wb)	58	TC	136.7	136.7	154.5	133.0	133.0	150.3	127.7	127.7	144.3	120.6	120.6	136.4
			SHC	118.9	136.7	154.5	115.7	133.0	150.3	111.0	127.7	144.3	104.9	120.6	136.4
		62	TC	142.2	142.2	147.8	137.4	137.4	147.1	131.0	131.0	144.7	122.8	122.8	140.3
			SHC	107.7	127.8	147.8	106.2	126.7	147.1	103.6	124.2	144.7	99.3	119.8	140.3
		67	TC	152.1	152.1	152.1	148.0	148	148	142.2	142.2	142.2	134.6	134.6	134.6
			SHC	84.8	104.3	123.7	83.8	103.8	123.7	82.0	102.3	122.6	79.4	99.9	120.4
		72	TC	161.3	161.3	161.3	157.8	157.8	157.8	152.5	152.5	152.5	145.4	145.4	145.4
			SHC	62.6	82.2	101.9	61.4	81.4	101.3	59.7	79.7	99.8	57.2	77.3	97.5
		76	TC	-	167.7	167.7	-	164.9	164.9	-	159.9	159.9	-	152.8	152.8
			SHC	-	66.4	91.4	-	65	89.2	-	63.1	86.4	-	60.5	83.1
5400 Cfm	EAT (wb)	58	TC	140.5	140.5	158.8	136.9	136.9	154.7	131.8	131.8	149	125.2	125.2	141.6
			SHC	122.2	140.5	158.8	119	136.9	154.7	114.7	131.8	149	108.9	125.2	141.6
		62	TC	144.3	144.3	155.7	139.6	139.6	155	133.5	133.5	152.4	125.8	125.8	147.8
			SHC	112.2	133.9	155.7	110.9	132.9	155	108.1	130.2	152.4	103.9	125.8	147.8
		67	TC	154.2	154.2	154.2	150.0	150.0	150.0	144.2	144.2	144.2	136.7	136.7	136.7
			SHC	87.6	108.6	129.6	86.8	108.5	130.1	85.2	107.3	129.4	82.8	105.1	127.4
		72	TC	163.1	163.1	163.1	159.7	159.7	159.7	154.3	154.3	154.3	147.1	147.1	147.1
			SHC	63.6	84.6	105.6	62.5	83.9	105.4	60.8	82.5	104.2	58.4	80.2	102
		76	TC	-	169.3	169.3	-	166.5	166.5	-	161.5	161.5	-	154.2	154.2
			SHC	-	67.6	93.7	-	66.4	91.7	-	64.5	89.2	-	61.9	86.1
6000 Cfm	EAT (wb)	58	TC	143.6	143.6	162.3	140.1	140.1	158.3	135.1	135.1	152.7	128.7	128.7	145.5
			SHC	124.9	143.6	162.3	121.8	140.1	158.3	117.5	135.1	152.7	111.9	128.7	145.5
		62	TC	146.1	146.1	162.4	141.7	141.7	161.5	135.6	135.6	159.2	128.8	128.8	151.2
			SHC	116.1	139.3	162.4	114.7	138.1	161.5	112.1	135.6	159.2	106.4	128.8	151.2
		67	TC	155.8	155.8	155.8	151.6	151.6	151.6	145.9	145.9	145.9	138.3	138.3	138.3
			SHC	90.1	112.6	135	89.6	112.8	136	88.3	112.0	135.8	85.9	110.0	134.1
		72	TC	164.5	164.5	164.5	161.2	161.2	161.2	155.8	155.8	155.8	148.5	148.5	148.5
			SHC	64.5	86.7	108.9	63.5	86.3	109.1	61.9	85.1	108.2	59.6	82.9	106.3
		76	TC	-	170.6	170.6	-	167.8	167.8	-	162.8	162.8	-	155.5	155.5
			SHC	-	68.7	95.8	-	67.5	94.1	-	65.7	91.8	-	63.3	88.8

LEGEND:

- Do not operate in this region
- Cfm - Cubic feet per minute (supply air)
- EAT(db) - Entering air temperature (dry bulb)
- EAT(wb) - Entering air temperature (wet bulb)
- SHC - Sensible heat capacity
- TC - Total capacity

Table 25 – COOLING CAPACITIES 15 TONS – Two Stage Cooling

RGS180				Ambient Temperature											
				85			95			105			115		
				EA (dB)			EA (dB)			EA (dB)			EA (dB)		
				75	80	85	75	80	85	75	80	85	75	80	85
4500 Cfm	EAT (wb)	58	THC	156.6	156.6	175.2	149.4	149.4	169.1	141.6	141.6	160.2	133.3	133.3	150.9
			SHC	134.7	154.9	175.2	129.8	149.4	169.1	123.0	141.6	160.2	115.7	133.3	150.9
		62	THC	166.7	166.7	166.9	158.0	158.0	162.6	147.6	147.6	157.2	136.8	136.8	150.3
			SHC	122.8	144.9	166.9	118.6	140.6	162.6	113.5	135.3	157.2	107.4	128.8	150.3
		67	THC	184.1	184.1	184.1	175.6	175.6	175.6	165.6	165.6	165.6	154.5	154.5	154.5
	SHC		101.6	123.7	145.7	98.1	120.2	142.3	94.0	116.1	138.2	89.4	111.5	133.6	
	72	THC	200.3	200.3	200.3	192.0	192.0	192.0	182.9	182.9	182.9	172.2	172.2	172.2	
		SHC	78.7	101.1	123.5	75.5	97.9	120.2	72.1	94.4	116.7	68.2	90.5	112.7	
	76	THC	-	211.4	211.4	-	203.1	203.1	-	193.8	193.8	-	183.9	183.9	
		SHC	-	82.2	107.0	-	79.3	103.8	-	76.0	100.2	-	72.6	96.5	
5250 Cfm	EAT (wb)	58	THC	165.2	165.2	186.9	158.2	158.2	179.0	150.0	150.0	169.7	141.3	141.3	160.0
			SHC	143.5	165.2	186.9	137.4	158.2	179.0	130.2	150.0	169.7	122.7	141.3	160.0
		62	THC	172.3	172.3	181.7	163.4	163.4	176.9	153.1	153.1	169.3	143.4	143.4	161.4
			SHC	131.6	156.6	181.7	127.1	152.0	176.9	120.5	144.9	169.3	114.1	137.8	161.4
		67	THC	189.5	189.5	189.5	180.9	180.9	180.9	170.7	170.7	170.7	159.1	159.1	159.1
	SHC		107.2	132.4	157.5	103.8	129.0	154.1	99.9	125.1	150.4	95.3	120.6	145.8	
	72	THC	205.0	205.0	205.0	196.5	196.5	196.5	187.1	187.1	187.1	176.4	176.4	176.4	
		SHC	80.9	106.1	131.3	77.7	102.9	128.1	74.4	99.5	124.7	70.6	95.8	121.0	
	76	THC	-	215.4	215.4	-	206.8	206.8	-	197.1	197.1	-	186.9	186.9	
		SHC	-	85.0	113.0	-	82.0	109.8	-	78.8	106.4	-	75.4	102.8	
6000 Cfm	EAT (wb)	58	THC	172.7	172.7	195.4	165.5	165.5	187.3	157.1	157.1	177.8	148.1	148.1	167.7
			SHC	150.0	172.7	195.4	143.8	165.5	187.3	136.4	157.1	177.8	128.6	148.1	167.7
		62	THC	176.6	176.6	195.7	168.1	168.1	187.6	158.9	158.9	180.2	148.9	148.9	172.1
			SHC	139.6	167.7	195.7	133.2	160.4	187.6	127.1	153.7	180.2	120.7	146.4	172.1
		67	THC	193.6	193.6	193.6	184.8	184.8	184.8	174.7	174.7	174.7	162.7	162.7	162.7
	SHC		112.3	140.3	168.3	108.9	137.0	165.2	105.2	133.5	161.7	100.7	129.0	157.3	
	72	THC	208.4	208.4	208.4	199.6	199.6	199.6	190.2	190.2	190.2	179.5	179.5	179.5	
		SHC	82.7	110.5	138.3	79.6	107.3	135.1	76.2	104.0	131.8	72.6	100.6	128.5	
	76	THC	-	218.2	218.2	-	209.5	209.5	-	199.5	199.5	-	189.0	189.0	
		SHC	-	87.5	118.6	-	84.5	115.2	-	81.1	111.3	-	77.5	107.3	
6750 Cfm	EAT (wb)	58	THC	178.8	178.8	202.4	171.6	171.6	194.2	163.1	163.1	184.6	153.8	153.8	174.1
			SHC	155.3	178.8	202.4	149.0	171.6	194.2	141.6	163.1	184.6	133.5	153.8	174.1
		62	THC	181.0	181.0	203.6	173.0	173.0	197.5	163.8	163.8	190.1	153.9	153.9	181.1
			SHC	144.1	173.9	203.6	139.1	168.3	197.5	133.3	161.7	190.1	126.7	153.9	181.1
		67	THC	196.8	196.8	196.8	187.9	187.9	187.9	177.7	177.7	177.7	165.5	165.5	167.9
	SHC		117.0	147.7	178.4	113.7	144.5	175.4	110.1	141.1	172.2	105.6	136.8	167.9	
	72	THC	211.0	211.0	211.0	202.2	202.2	202.2	192.5	192.5	192.5	181.8	181.8	181.8	
		SHC	84.3	114.5	144.7	81.2	111.5	141.7	77.9	108.1	138.4	74.4	104.9	135.4	
	76	THC	-	220.2	220.2	-	211.5	211.5	-	201.3	201.3	-	190.6	190.6	
		SHC	-	89.5	122.8	-	86.4	119.4	-	83.0	115.4	-	79.4	111.5	
7500 Cfm	EAT (wb)	58	THC	183.9	183.9	208.2	176.6	176.6	199.8	168.2	168.2	190.3	158.6	158.6	179.5
			SHC	159.7	183.9	208.2	153.3	176.6	199.8	146.0	168.2	190.3	137.7	158.6	179.5
		62	THC	185.1	185.1	212.5	177.1	177.1	206.2	168.3	168.3	197.9	158.7	158.7	186.7
			SHC	149.5	181.0	212.5	144.5	175.4	206.2	138.7	168.3	197.9	130.8	158.7	186.7
		67	THC	199.3	199.3	199.3	190.3	190.3	190.3	180.0	180.0	181.7	167.8	167.8	177.8
	SHC		121.3	154.6	187.9	118.1	151.6	185.1	114.4	148.1	181.7	110.1	144.0	177.8	
	72	THC	213.0	213.0	213.0	204.1	204.1	204.1	194.2	194.2	194.2	183.5	183.5	183.5	
		SHC	85.8	118.2	150.5	82.7	115.2	147.7	79.4	111.9	144.4	76.0	108.8	141.6	
	76	THC	-	221.9	221.9	-	213.0	213.0	-	202.7	202.7	-	191.8	191.8	
		SHC	-	91.2	126.5	-	88.2	123.1	-	84.7	119.2	-	81.2	115.3	

LEGEND:

- Do not operate in this region
- Cfm – Cubic feet per minute (supply air)
- EAT(db) – Entering air temperature (dry bulb)
- EAT(wb) – Entering air temperature (wet bulb)
- SHC – Sensible heat capacity
- TC – Total capacity

General fan performance notes:

1. Interpolation is permissible. Do not extrapolate.
2. External static pressure is the static pressure difference between the return duct and the supply duct plus the static pressure caused by any FIOPs or accessories.
3. Tabular data accounts for pressure loss due to clean filters, unit casing, and wet coils. Factory options and accessories may add static pressure losses. Selection software is available to help you select the best motor/drive combination for your application.
4. The Fan Performance tables offer motor/drive recommendations. In cases when two motor/drive combinations would work, recommend the lower horsepower option.
5. For information on the electrical properties of motors, please see the Electrical information section of this book.
6. For more information on the performance limits of motors, see the application data section of this book.

ECONOMIZER, BAROMETRIC RELIEF, AND PERFORMANCE

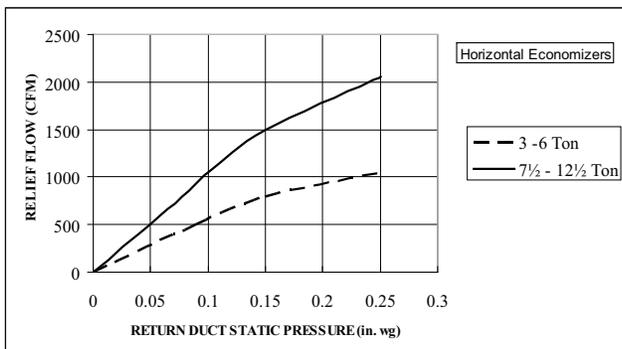

FIGURE 1 – Barometric Relief Flow Capacity C08070

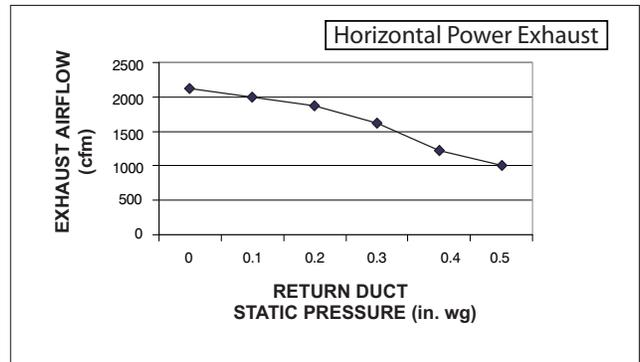

FIGURE 4 – Horizontal Power Exhaust Performance C08012

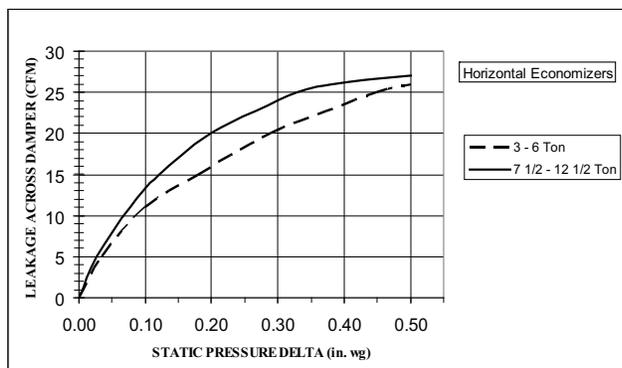

FIGURE 2 – Outdoor Air Damper Leakage C08071

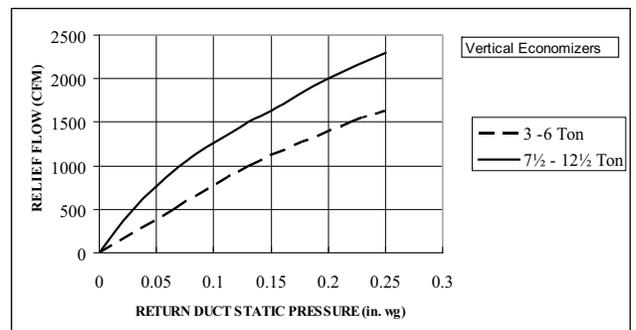

FIGURE 5 – Barometric Relief Flow Capacity C08073

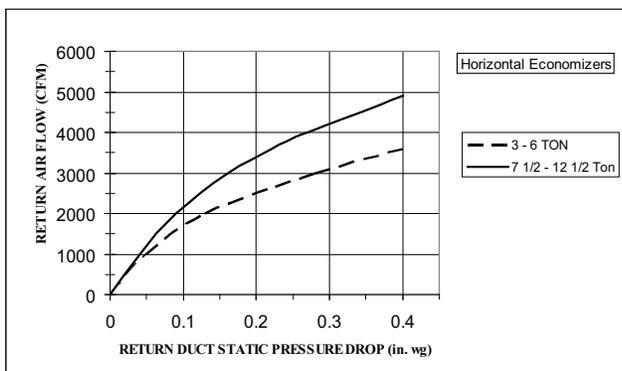

FIGURE 3 – Return Air Pressure Drop C08072

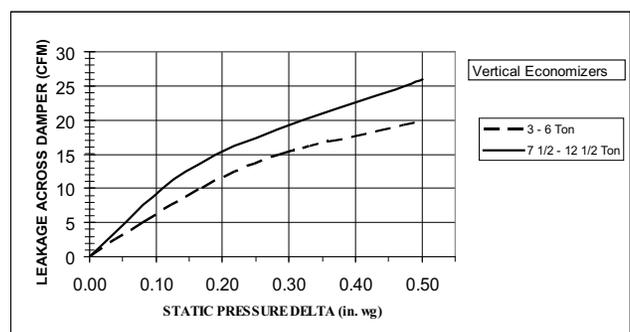

FIGURE 6 – Outdoor Air Damper Leakage C08074

ECONOMIZER, BAROMETRIC RELIEF, AND PERFORMANCE (CONT.)

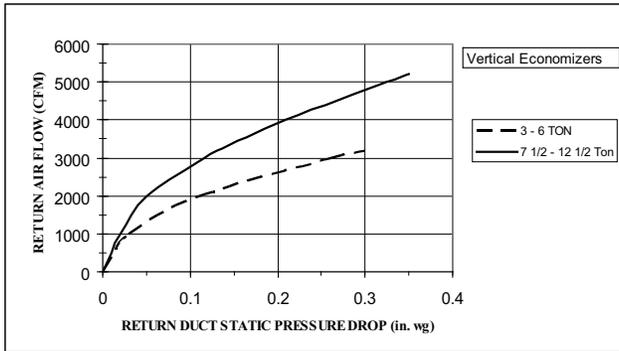

FIGURE 7 – Return Air Pressure Drop

C08075

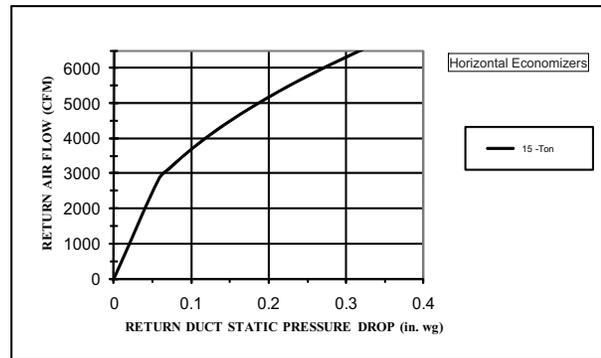

FIGURE 10 – Return Air Pressure Drop–Horizontal 15 Ton

C101121

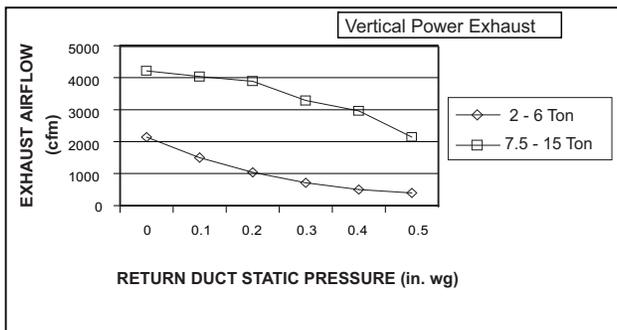

FIGURE 8 – Vertical Power Exhaust Performance

101125

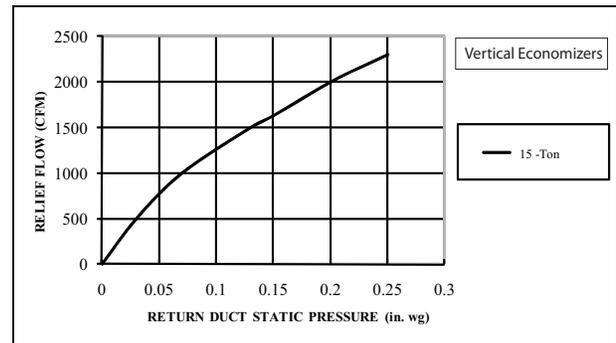

FIGURE 11 – Barometric Relief Flow–Vertical 15 Ton

C101122

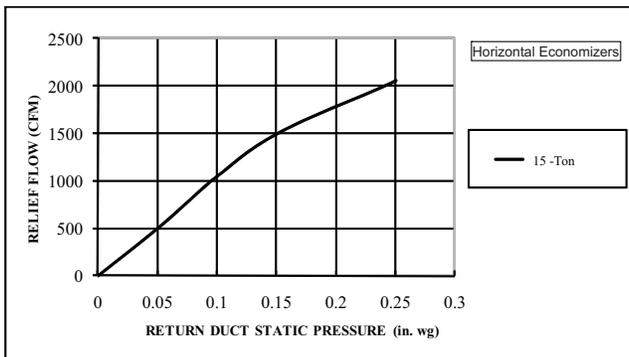

FIGURE 9 – Barometric Relief Flow–Horizontal 15 Ton

C101120

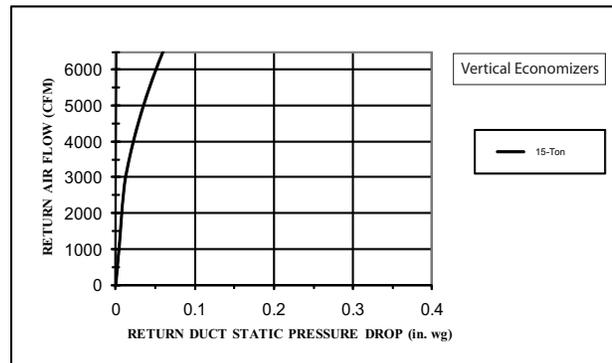

FIGURE 12 – Return Air Pressure Drop–Vertical 15 Tons

C101123

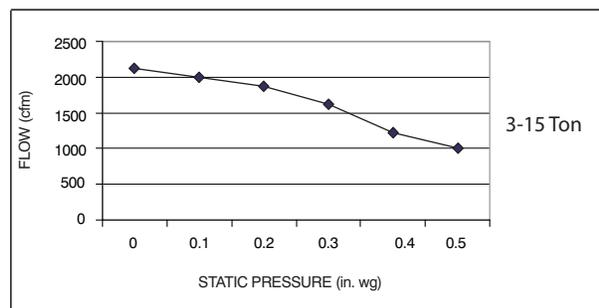

FIGURE 13 – Horizontal Power Exhaust Performance

C101124

FAN PERFORMANCE

Table 26 – RGS036, 1 PHASE, 3 TON HORIZONTAL SUPPLY

CFM	AVAILABLE EXTERNAL STATIC PRESSURE (in. wg)									
	0.2		0.4		0.6		0.8		1.0	
	RPM	BHP	RPM	BHP	RPM	BHP	RPM	BHP	RPM	BHP
	Field-Supplied Drive¹		Standard Static Option				Medium Static Option			
900	553	0.14	681	0.22	782	0.32	870	0.42	948	0.53
975	575	0.16	700	0.25	801	0.35	888	0.46	965	0.57
1050	597	0.18	720	0.28	820	0.38	906	0.49	983	0.61
1125	620	0.21	741	0.31	839	0.42	925	0.54	1001	0.66
1200	643	0.23	762	0.34	859	0.46	944	0.58	1020	0.71
1275	667	0.27	783	0.38	879	0.50	963	0.63	1038	0.76
1350	691	0.30	805	0.42	900	0.55	983	0.68	1057	0.82
1425	715	0.34	827	0.47	920	0.60	1002	0.74	1076	0.88
1500	740	0.38	849	0.52	941	0.66	1023	0.80	1096	0.95

CFM	AVAILABLE EXTERNAL STATIC PRESSURE (in. wg)									
	1.2		1.4		1.6		1.8		2.0	
	RPM	BHP	RPM	BHP	RPM	BHP	RPM	BHP	RPM	BHP
	Medium Static Option					Field-Supplied Drive²				
900	1019	0.64	1084	0.76	1146	0.89	1203	1.02	1258	1.16
975	1036	0.69	1101	0.81	1162	0.94	1219	1.08	-	-
1050	1053	0.74	1118	0.86	1179	1.00	1236	1.14	-	-
1125	1071	0.79	1135	0.92	1196	1.06	1253	1.20	-	-
1200	1089	0.84	1153	0.98	1213	1.12	-	-	-	-
1275	1107	0.90	1171	1.04	1231	1.19	-	-	-	-
1350	1126	0.96	1189	1.11	-	-	-	-	-	-
1425	1144	1.03	1208	1.18	-	-	-	-	-	-
1500	1163	1.10	-	-	-	-	-	-	-	-

NOTE: For more information, see General Fan Performance Notes on page 46.

Boldface indicates field-supplied drive is required.

1. Recommend using field-supplied fan pulley (part number 1178448) and belt (part number 1177401).
2. Recommend using field-supplied motor pulley (part number 1175832) and belt (part number 1178128).

Table 27 – RGS036, 1 PHASE, 3 TON VERTICAL SUPPLY

CFM	AVAILABLE EXTERNAL STATIC PRESSURE (in. wg)									
	0.2		0.4		0.6		0.8		1.0	
	RPM	BHP	RPM	BHP	RPM	BHP	RPM	BHP	RPM	BHP
	Field-Supplied Drive¹		Standard Static Option				Medium Static Option			
900	567	0.15	688	0.22	786	0.30	871	0.37	947	0.44
975	591	0.17	710	0.26	807	0.34	891	0.42	966	0.49
1050	615	0.20	732	0.29	828	0.38	911	0.47	985	0.55
1125	641	0.23	755	0.33	849	0.42	931	0.52	1005	0.61
1200	666	0.26	778	0.37	871	0.47	952	0.57	1025	0.67
1275	693	0.29	802	0.41	893	0.53	974	0.63	1046	0.74
1350	719	0.33	826	0.46	916	0.58	995	0.70	1067	0.81
1425	746	0.38	850	0.51	939	0.64	1017	0.76	1088	0.89
1500	773	0.42	875	0.57	963	0.70	1040	0.84	1110	0.96

CFM	AVAILABLE EXTERNAL STATIC PRESSURE (in. wg)									
	1.2		1.4		1.6		1.8		2.0	
	RPM	BHP	RPM	BHP	RPM	BHP	RPM	BHP	RPM	BHP
	Medium Static Option					Field-Supplied Drive²				
900	1016	0.51	1080	0.57	1139	0.64	1195	0.71	1249	0.77
975	1034	0.57	1098	0.64	1157	0.72	1213	0.79	1266	0.86
1050	1053	0.63	1116	0.71	1176	0.79	1231	0.87	1284	0.95
1125	1073	0.70	1135	0.79	1194	0.87	1250	0.96	1302	1.04
1200	1093	0.77	1155	0.87	1213	0.96	1268	1.05	1321	1.14
1275	1113	0.85	1174	0.95	1232	1.05	1287	1.15	-	-
1350	1133	0.92	1194	1.03	1252	1.14	-	-	-	-
1425	1154	1.01	1215	1.12	-	-	-	-	-	-
1500	1175	1.09	-	-	-	-	-	-	-	-

NOTE: For more information, see General Fan Performance Notes on page 46.

Boldface indicates field-supplied drive is required.

1. Recommend using field-supplied fan pulley (part number 1178448) and belt (part number 1177401).
2. Recommend using field-supplied motor pulley (part number 1175832) and belt (part number 1178128).

FAN PERFORMANCE (cont.)

Table 28 – RGS036, 3 PHASE, 3 TON HORIZONTAL SUPPLY

CFM	AVAILABLE EXTERNAL STATIC PRESSURE (in. wg)									
	0.2		0.4		0.6		0.8		1.0	
	RPM	BHP	RPM	BHP	RPM	BHP	RPM	BHP	RPM	BHP
	Field-Supplied Drive¹		Standard Static Option				Medium Static Option			
900	553	0.14	681	0.22	782	0.32	870	0.42	948	0.53
975	575	0.16	700	0.25	801	0.35	888	0.46	965	0.57
1050	597	0.18	720	0.28	820	0.38	906	0.49	983	0.61
1125	620	0.21	741	0.31	839	0.42	925	0.54	1001	0.66
1200	643	0.23	762	0.34	859	0.46	944	0.58	1020	0.71
1275	667	0.27	783	0.38	879	0.50	963	0.63	1038	0.76
1350	691	0.30	805	0.42	900	0.55	983	0.68	1057	0.82
1425	715	0.34	827	0.47	920	0.60	1002	0.74	1076	0.88
1500	740	0.38	849	0.52	941	0.66	1023	0.80	1096	0.95

CFM	AVAILABLE EXTERNAL STATIC PRESSURE (in. wg)									
	1.2		1.4		1.6		1.8		2.0	
	RPM	BHP	RPM	BHP	RPM	BHP	RPM	BHP	RPM	BHP
	Medium Static Option					High Static Option				
900	1019	0.64	1084	0.76	1146	0.89	1203	1.02	1258	1.16
975	1036	0.69	1101	0.81	1162	0.94	1219	1.08	1274	1.22
1050	1053	0.74	1118	0.86	1179	1.00	1236	1.14	1290	1.28
1125	1071	0.79	1135	0.92	1196	1.06	1253	1.20	1307	1.35
1200	1089	0.84	1153	0.98	1213	1.12	1270	1.27	1324	1.42
1275	1107	0.90	1171	1.04	1231	1.19	1287	1.34	1341	1.50
1350	1126	0.96	1189	1.11	1249	1.26	1305	1.42	1358	1.58
1425	1144	1.03	1208	1.18	1267	1.34	1323	1.50	1376	1.66
1500	1163	1.10	1226	1.25	1285	1.41	1341	1.58	1394	1.75

NOTE: For more information, see General Fan Performance Notes on page 46.

1. Recommend using field-supplied blower pulley (part number 1178448) and belt (part number 1177401)

Table 29 – RGS036, 3 PHASE, 3 TON VERTICAL SUPPLY

CFM	AVAILABLE EXTERNAL STATIC PRESSURE (in. wg)									
	0.2		0.4		0.6		0.8		1.0	
	RPM	BHP	RPM	BHP	RPM	BHP	RPM	BHP	RPM	BHP
	Field-Supplied Drive¹		Standard Static Option				Medium Static Option			
900	567	0.15	688	0.22	786	0.30	871	0.37	947	0.44
975	591	0.17	710	0.26	807	0.34	891	0.42	966	0.49
1050	615	0.20	732	0.29	828	0.38	911	0.47	985	0.55
1125	641	0.23	755	0.33	849	0.42	931	0.52	1005	0.61
1200	666	0.26	778	0.37	871	0.47	952	0.57	1025	0.67
1275	693	0.29	802	0.41	893	0.53	974	0.63	1046	0.74
1350	719	0.33	826	0.46	916	0.58	995	0.70	1067	0.81
1425	746	0.38	850	0.51	939	0.64	1017	0.76	1088	0.89
1500	773	0.42	875	0.57	963	0.70	1040	0.84	1110	0.96

CFM	AVAILABLE EXTERNAL STATIC PRESSURE (in. wg)									
	1.2		1.4		1.6		1.8		2.0	
	RPM	BHP	RPM	BHP	RPM	BHP	RPM	BHP	RPM	BHP
	Medium Static Option					High Static Option				
900	1016	0.51	1080	0.57	1139	0.64	1195	0.71	1249	0.77
975	1034	0.57	1098	0.64	1157	0.72	1213	0.79	1266	0.86
1050	1053	0.63	1116	0.71	1176	0.79	1231	0.87	1284	0.95
1125	1073	0.70	1135	0.79	1194	0.87	1250	0.96	1302	1.04
1200	1093	0.77	1155	0.87	1213	0.96	1268	1.05	1321	1.14
1275	1113	0.85	1174	0.95	1232	1.05	1287	1.15	1339	1.25
1350	1133	0.92	1194	1.03	1252	1.14	1307	1.25	1358	1.35
1425	1154	1.01	1215	1.12	1272	1.24	1326	1.35	1378	1.46
1500	1175	1.09	1235	1.22	1292	1.34	1346	1.46	1397	1.58

NOTE: For more information, see General Fan Performance Notes on page 46.

Boldface indicates field-supplied drive is required.

1. Recommend using field-supplied blower pulley (part number 1178448) and belt (part number 1177401)

FAN PERFORMANCE (cont.)

Table 30 – RGS048, 1 PHASE, 4 TON HORIZONTAL SUPPLY

CFM	AVAILABLE EXTERNAL STATIC PRESSURE (in. wg)									
	0.2		0.4		0.6		0.8		1.0	
	RPM	BHP	RPM	BHP	RPM	BHP	RPM	BHP	RPM	BHP
	Standard Static Option					Medium Static Option				
1200	643	0.23	762	0.34	859	0.46	944	0.58	1020	0.71
1300	675	0.28	790	0.40	886	0.52	969	0.65	1044	0.78
1400	707	0.33	819	0.45	913	0.58	996	0.72	1070	0.86
1500	740	0.38	849	0.52	941	0.66	1023	0.80	1096	0.95
1600	773	0.45	879	0.59	970	0.73	1050	0.88	1123	1.04
1700	807	0.52	910	0.67	999	0.82	1078	0.98	1150	1.14
1800	841	0.59	942	0.75	1029	0.91	1106	1.08	1177	1.25
1900	875	0.68	974	0.85	1059	1.02	1135	1.19	1205	1.37
2000	910	0.77	1006	0.95	1090	1.13	1165	1.31	1234	1.49

CFM	AVAILABLE EXTERNAL STATIC PRESSURE (in. wg)									
	1.2		1.4		1.6		1.8		2.0	
	RPM	BHP	RPM	BHP	RPM	BHP	RPM	BHP	RPM	BHP
	Medium Static Option					Field-Supplied Drive ¹				
1200	1089	0.84	1153	0.98	1213	1.12	-	-	-	-
1300	1113	0.92	1177	1.06	-	-	-	-	-	-
1400	1138	1.01	1201	1.15	-	-	-	-	-	-
1500	1163	1.10	-	-	-	-	-	-	-	-
1600	1189	1.20	-	-	-	-	-	-	-	-
1700	-	-	-	-	-	-	-	-	-	-
1800	-	-	-	-	-	-	-	-	-	-
1900	-	-	-	-	-	-	-	-	-	-
2000	-	-	-	-	-	-	-	-	-	-

NOTE: For more information, see General Fan Performance Notes on page 46.

Boldface indicates field-supplied drive is required.

1. Recommend using field-supplied blower pulley (part number 1175832) and belt (part number 1178128)

Table 31 – RGS048, 1 PHASE, 4 TON VERTICAL SUPPLY

CFM	AVAILABLE EXTERNAL STATIC PRESSURE (in. wg)									
	0.2		0.4		0.6		0.8		1.0	
	RPM	BHP	RPM	BHP	RPM	BHP	RPM	BHP	RPM	BHP
	Standard Static Option					Medium Static Option				
1200	666	0.26	778	0.37	871	0.47	952	0.57	1025	0.67
1300	701	0.31	810	0.43	901	0.54	981	0.65	1053	0.76
1400	737	0.36	842	0.49	931	0.62	1010	0.74	1081	0.86
1500	773	0.42	875	0.57	963	0.70	1040	0.84	1110	0.96
1600	810	0.49	909	0.65	994	0.79	1070	0.94	1140	1.08
1700	847	0.57	943	0.73	1027	0.89	1101	1.05	1170	1.20
1800	885	0.66	978	0.83	1060	1.00	1133	1.16	1200	1.32
1900	923	0.75	1014	0.94	1093	1.11	1165	1.29	1231	1.46
2000	962	0.85	1049	1.05	1127	1.24	1198	1.42	1263	1.61

CFM	AVAILABLE EXTERNAL STATIC PRESSURE (in. wg)									
	1.2		1.4		1.6		1.8		2.0	
	RPM	BHP	RPM	BHP	RPM	BHP	RPM	BHP	RPM	BHP
	Medium Static Option					Field-Supplied Drive ¹				
1200	1093	0.77	1155	0.87	1213	0.96	1268	1.05	1321	1.14
1300	1119	0.87	1181	0.98	1239	1.08	1294	1.18	-	-
1400	1147	0.98	1208	1.09	-	-	-	-	-	-
1500	1175	1.09	-	-	-	-	-	-	-	-
1600	-	-	-	-	-	-	-	-	-	-
1700	-	-	-	-	-	-	-	-	-	-
1800	-	-	-	-	-	-	-	-	-	-
1900	-	-	-	-	-	-	-	-	-	-
2000	-	-	-	-	-	-	-	-	-	-

NOTE: For more information, see General Fan Performance Notes on page 46.

Boldface indicates field-supplied drive is required.

1. Recommend using field-supplied blower pulley (part number 1175832) and belt (part number 1178128)

FAN PERFORMANCE (cont.)

Table 32 – RGS048, 3 PHASE, 4 TON HORIZONTAL SUPPLY

CFM	AVAILABLE EXTERNAL STATIC PRESSURE (in. wg)									
	0.2		0.4		0.6		0.8		1.0	
	RPM	BHP	RPM	BHP	RPM	BHP	RPM	BHP	RPM	BHP
Standard Static Option					Medium Static Option					
1200	643	0.23	762	0.34	859	0.46	944	0.58	1020	0.71
1300	675	0.28	790	0.40	886	0.52	969	0.65	1044	0.78
1400	707	0.33	819	0.45	913	0.58	996	0.72	1070	0.86
1500	740	0.38	849	0.52	941	0.66	1023	0.80	1096	0.95
1600	773	0.45	879	0.59	970	0.73	1050	0.88	1123	1.04
1700	807	0.52	910	0.67	999	0.82	1078	0.98	1150	1.14
1800	841	0.59	942	0.75	1029	0.91	1106	1.08	1177	1.25
1900	875	0.68	974	0.85	1059	1.02	1135	1.19	1205	1.37
2000	910	0.77	1006	0.95	1090	1.13	1165	1.31	1234	1.49

CFM	AVAILABLE EXTERNAL STATIC PRESSURE (in. wg)									
	1.2		1.4		1.6		1.8		2.0	
	RPM	BHP	RPM	BHP	RPM	BHP	RPM	BHP	RPM	BHP
Medium Static Option					High Static Option					
1200	1089	0.84	1153	0.98	1213	1.12	1270	1.27	1324	1.42
1300	1113	0.92	1177	1.06	1237	1.21	1293	1.36	1347	1.52
1400	1138	1.01	1201	1.15	1261	1.31	1317	1.47	1370	1.63
1500	1163	1.10	1226	1.25	1285	1.41	1341	1.58	1394	1.75
1600	1189	1.20	1252	1.36	1310	1.53	1365	1.70	1418	1.87
1700	1216	1.31	1277	1.48	1335	1.65	1390	1.83	1442	2.01
1800	1242	1.42	1303	1.60	1361	1.78	1415	1.96	1467	2.15
1900	1270	1.55	1330	1.73	1387	1.92	1441	2.11	1493	2.30
2000	1297	1.68	1357	1.87	1414	2.07	1467	2.26	-	-

NOTE: For more information, see General Fan Performance Notes on page 46.

Boldface indicates field-supplied drive is required.

1. Recommend using field-supplied blower pulley (part no. 1175314), motor pulley (part no. 1170551) and belt (part no. 1178451).

Table 33 – RGS048, 3 PHASE, 4 TON VERTICAL SUPPLY

CFM	AVAILABLE EXTERNAL STATIC PRESSURE (in. wg)									
	0.2		0.4		0.6		0.8		1.0	
	RPM	BHP	RPM	BHP	RPM	BHP	RPM	BHP	RPM	BHP
Standard Static Option					Medium Static Option					
1200	666	0.26	778	0.37	871	0.47	952	0.57	1025	0.67
1300	701	0.31	810	0.43	901	0.54	981	0.65	1053	0.76
1400	737	0.36	842	0.49	931	0.62	1010	0.74	1081	0.86
1500	773	0.42	875	0.57	963	0.70	1040	0.84	1110	0.96
1600	810	0.49	909	0.65	994	0.79	1070	0.94	1140	1.08
1700	847	0.57	943	0.73	1027	0.89	1101	1.05	1170	1.20
1800	885	0.66	978	0.83	1060	1.00	1133	1.16	1200	1.32
1900	923	0.75	1014	0.94	1093	1.11	1165	1.29	1231	1.46
2000	962	0.85	1049	1.05	1127	1.24	1198	1.42	1263	1.61

CFM	AVAILABLE EXTERNAL STATIC PRESSURE (in. wg)									
	1.2		1.4		1.6		1.8		2.0	
	RPM	BHP	RPM	BHP	RPM	BHP	RPM	BHP	RPM	BHP
Medium Static Option					High Static Option					
1200	1093	0.77	1155	0.87	1213	0.96	1268	1.05	1321	1.14
1300	1119	0.87	1181	0.98	1239	1.08	1294	1.18	1346	1.28
1400	1147	0.98	1208	1.09	1265	1.21	1320	1.32	1371	1.43
1500	1175	1.09	1235	1.22	1292	1.34	1346	1.46	1397	1.58
1600	1204	1.21	1263	1.35	1320	1.48	1373	1.61	1424	1.74
1700	1233	1.34	1292	1.49	1348	1.63	1401	1.77	1451	1.91
1800	1262	1.48	1321	1.64	1376	1.79	1428	1.94	1479	2.09
1900	1293	1.63	1350	1.79	1405	1.96	1457	2.12	1506	2.28
2000	1323	1.79	1380	1.96	1434	2.13	1486	2.31	-	-

NOTE: For more information, see General Fan Performance Notes on page 46.

Boldface indicates field-supplied drive is required.

1. Recommend using field-supplied blower pulley (part no. 1175314), motor pulley (part no. 1170551) and belt (part no. 1178451).

FAN PERFORMANCE (cont.)

Table 34 – RGS060, 1 PHASE, 5 TON HORIZONTAL SUPPLY

CFM	AVAILABLE EXTERNAL STATIC PRESSURE (in. wg)									
	0.2		0.4		0.6		0.8		1.0	
	RPM	BHP	RPM	BHP	RPM	BHP	RPM	BHP	RPM	BHP
	Standard Static Option								Medium Static Option	
1500	800	0.39	904	0.49	999	0.60	1087	0.72	1169	0.85
1625	849	0.48	947	0.59	1038	0.70	1122	0.83	1201	0.96
1750	899	0.59	992	0.70	1078	0.82	1159	0.95	1235	1.08
1875	950	0.70	1038	0.82	1120	0.95	1198	1.08	1271	1.22
2000	1001	0.84	1085	0.96	1163	1.09	1238	1.23	1309	1.38
2125	1053	0.99	1133	1.12	1208	1.26	1280	1.40	-	-
2250	1106	1.16	1182	1.29	1254	1.44	-	-	-	-
2375	1159	1.34	1231	1.49	-	-	-	-	-	-
2500	-	-	-	-	-	-	-	-	-	-

CFM	AVAILABLE EXTERNAL STATIC PRESSURE (in. wg)									
	1.2		1.4		1.6		1.8		2.0	
	RPM	BHP	RPM	BHP	RPM	BHP	RPM	BHP	RPM	BHP
	Medium Static Option									
1500	1247	0.98	1320	1.13	1390	1.28	1457	1.44	-	-
1625	1276	1.10	1348	1.24	1416	1.40	-	-	-	-
1750	1308	1.22	1377	1.38	-	-	-	-	-	-
1875	1342	1.37	-	-	-	-	-	-	-	-
2000	-	-	-	-	-	-	-	-	-	-
2125	-	-	-	-	-	-	-	-	-	-
2250	-	-	-	-	-	-	-	-	-	-
2375	-	-	-	-	-	-	-	-	-	-
2500	-	-	-	-	-	-	-	-	-	-

NOTE: For more information, see General Fan Performance Notes on page 46.

Table 35 – RGS060, 1 PHASE, 5 TON VERTICAL SUPPLY

CFM	AVAILABLE EXTERNAL STATIC PRESSURE (in. wg)									
	0.2		0.4		0.6		0.8		1.0	
	RPM	BHP	RPM	BHP	RPM	BHP	RPM	BHP	RPM	BHP
	Standard Static Option								Medium Static Option	
1500	848	0.42	968	0.55	1069	0.68	1158	0.80	1238	0.94
1625	897	0.51	1013	0.65	1111	0.79	1198	0.93	1277	1.07
1750	947	0.61	1059	0.76	1155	0.91	1240	1.06	1318	1.21
1875	997	0.72	1105	0.89	1199	1.05	1283	1.21	1359	1.37
2000	1048	0.85	1153	1.03	1244	1.20	1326	1.37	-	-
2125	1100	1.00	1201	1.19	1290	1.37	-	-	-	-
2250	1152	1.16	1250	1.36	-	-	-	-	-	-
2375	1205	1.34	-	-	-	-	-	-	-	-
2500	-	-	-	-	-	-	-	-	-	-

CFM	AVAILABLE EXTERNAL STATIC PRESSURE (in. wg)									
	1.2		1.4		1.6		1.8		2.0	
	RPM	BHP	RPM	BHP	RPM	BHP	RPM	BHP	RPM	BHP
	Medium Static Option								Field-Supplied Drive ¹	
1500	1312	1.07	1380	1.20	1445	1.34	1506	1.48	-	-
1625	1350	1.21	1418	1.35	1482	1.50	-	-	-	-
1750	1390	1.36	-	-	-	-	-	-	-	-
1875	-	-	-	-	-	-	-	-	-	-
2000	-	-	-	-	-	-	-	-	-	-
2125	-	-	-	-	-	-	-	-	-	-
2250	-	-	-	-	-	-	-	-	-	-

NOTE: For more information, see General Fan Performance Notes on page 46.

Boldface indicates field-supplied drive is required.

1. Recommend using field-supplied motor pulley (part number 1175494) and belt (part number 1177401).

FAN PERFORMANCE (cont.)

Table 36 – RGS060, 3 PHASE, 5 TON HORIZONTAL SUPPLY

CFM	AVAILABLE EXTERNAL STATIC PRESSURE (in. wg)									
	0.2		0.4		0.6		0.8		1.0	
	RPM	BHP	RPM	BHP	RPM	BHP	RPM	BHP	RPM	BHP
	Standard Static Option						Medium Static Option			
1500	800	0.39	904	0.49	999	0.60	1087	0.72	1169	0.85
1625	849	0.48	947	0.59	1038	0.70	1122	0.83	1201	0.96
1750	899	0.59	992	0.70	1078	0.82	1159	0.95	1235	1.08
1875	950	0.70	1038	0.82	1120	0.95	1198	1.08	1271	1.22
2000	1001	0.84	1085	0.96	1163	1.09	1238	1.23	1309	1.38
2125	1053	0.99	1133	1.12	1208	1.26	1280	1.40	1348	1.55
2250	1106	1.16	1182	1.29	1254	1.44	1323	1.59	1389	1.74
2375	1159	1.34	1231	1.49	1300	1.64	1367	1.80	1430	1.96
2500	1212	1.55	1281	1.70	1348	1.86	1412	2.02	1473	2.19

CFM	AVAILABLE EXTERNAL STATIC PRESSURE (in. wg)									
	1.2		1.4		1.6		1.8		2.0	
	RPM	BHP	RPM	BHP	RPM	BHP	RPM	BHP	RPM	BHP
	Medium Static Option						High Static Option			
1500	1247	0.98	1320	1.13	1390	1.28	1457	1.44	1522	1.61
1625	1276	1.10	1348	1.24	1416	1.40	1481	1.56	1544	1.73
1750	1308	1.22	1377	1.38	1444	1.53	1507	1.70	1569	1.87
1875	1342	1.37	1409	1.52	1473	1.69	1536	1.86	1596	2.03
2000	1377	1.53	1442	1.69	1505	1.86	1565	2.03	1624	2.21
2125	1414	1.71	1477	1.87	1538	2.04	1597	2.22	1654	2.40
2250	1452	1.91	1514	2.08	1573	2.25	1630	2.43	1686	2.62
2375	1492	2.12	1551	2.30	1609	2.48	1665	2.66	1719	2.85
2500	1533	2.36	1591	2.54	1647	2.73	-	-	-	-

NOTE: For more information, see General Fan Performance Notes on page 46.

Boldface indicates field-supplied drive is required. Recommend using field-supplied fan pulley (part number 1175314) motor pulley (part no. 1178187), and belt (part number 1179766)

Table 37 – RGS060, 3 PHASE, 5 TON VERTICAL SUPPLY

CFM	AVAILABLE EXTERNAL STATIC PRESSURE (in. wg)									
	0.2		0.4		0.6		0.8		1.0	
	RPM	BHP	RPM	BHP	RPM	BHP	RPM	BHP	RPM	BHP
	Standard Static Option						Medium Static Option			
1500	848	0.42	968	0.55	1069	0.68	1158	0.80	1238	0.94
1625	897	0.51	1013	0.65	1111	0.79	1198	0.93	1277	1.07
1750	947	0.61	1059	0.76	1155	0.91	1240	1.06	1318	1.21
1875	997	0.72	1105	0.89	1199	1.05	1283	1.21	1359	1.37
2000	1048	0.85	1153	1.03	1244	1.20	1326	1.37	1401	1.54
2125	1100	1.00	1201	1.19	1290	1.37	1370	1.55	1444	1.73
2250	1152	1.16	1250	1.36	1336	1.55	1415	1.75	1487	1.94
2375	1205	1.34	1299	1.55	1384	1.76	1460	1.96	1532	2.17
2500	1258	1.54	1349	1.76	1431	1.98	1506	2.20	1576	2.41

CFM	AVAILABLE EXTERNAL STATIC PRESSURE (in. wg)									
	1.2		1.4		1.6		1.8		2.0	
	RPM	BHP	RPM	BHP	RPM	BHP	RPM	BHP	RPM	BHP
	Medium Static Option						High Static Option			
1500	1312	1.07	1380	1.20	1445	1.34	1506	1.48	1564	1.62
1625	1350	1.21	1418	1.35	1482	1.50	1542	1.64	1600	1.79
1750	1390	1.36	1457	1.51	1520	1.67	1580	1.83	1637	1.98
1875	1430	1.53	1496	1.69	1559	1.86	1618	2.02	1675	2.19
2000	1471	1.72	1536	1.89	1598	2.06	1657	2.24	1713	2.41
2125	1513	1.92	1577	2.10	1638	2.28	1696	2.47	1752	2.65
2250	1555	2.13	1619	2.33	1679	2.52	1736	2.72	-	-
2375	1598	2.37	1661	2.57	1720	2.78	-	-	-	-
2500	1642	2.63	1704	2.84	-	-	-	-	-	-

NOTE: For more information, see General Fan Performance Notes on page 46.

Boldface indicates field-supplied drive is required. Recommend using field-supplied fan pulley (part number 1175314) motor pulley (part no. 1178187), and belt (part number 1179766)

FAN PERFORMANCE (cont.)

Table 38 – RGS072, 3 PHASE, 6 TON HORIZONTAL SUPPLY

CFM	AVAILABLE EXTERNAL STATIC PRESSURE (in. wg)									
	0.2		0.4		0.6		0.8		1.0	
	RPM	BHP	RPM	BHP	RPM	BHP	RPM	BHP	RPM	BHP
	Field-Supplied Drive¹		Standard Static Option						Medium Static Option	
1800	913	0.64	1010	0.80	1098	0.98	1178	1.16	1252	1.35
1950	972	0.78	1065	0.96	1148	1.14	1226	1.34	1298	1.54
2100	1032	0.95	1120	1.14	1200	1.33	1275	1.54	1345	1.75
2250	1093	1.14	1177	1.34	1254	1.55	1325	1.76	1393	1.98
2400	1155	1.36	1234	1.57	1308	1.78	1377	2.01	1443	2.24
2550	1217	1.60	1293	1.82	1363	2.05	1430	2.28	1494	2.53
2700	1280	1.87	1352	2.10	1420	2.34	1484	2.59	1546	2.84
2850	1343	2.17	1412	2.42	1477	2.67	1539	2.93	1599	3.19
3000	1406	2.50	1472	2.76	1535	3.03	1595	3.29	1653	3.57

CFM	AVAILABLE EXTERNAL STATIC PRESSURE (in. wg)									
	1.2		1.4		1.6		1.8		2.0	
	RPM	BHP	RPM	BHP	RPM	BHP	RPM	BHP	RPM	BHP
	Medium Static Option						High Static Option			
1800	1322	1.56	1388	1.77	1451	1.98	1510	2.21	1568	2.44
1950	1366	1.75	1430	1.97	1491	2.20	1550	2.43	1606	2.67
2100	1411	1.97	1473	2.20	1533	2.43	1590	2.67	1645	2.92
2250	1457	2.21	1518	2.45	1576	2.69	1632	2.94	1686	3.20
2400	1505	2.48	1564	2.73	1621	2.98	1676	3.24	1729	3.51
2550	1554	2.78	1612	3.03	1667	3.30	1721	3.57	-	-
2700	1604	3.10	1660	3.37	1715	3.64	-	-	-	-
2850	1656	3.46	-	-	-	-	-	-	-	-

NOTE: For more information, see General Fan Performance Notes on page 46.

Boldface indicates field-supplied drive is required.

1. Recommend using field-supplied blower pulley (part no. 1175830), motor pulley (part no. 1175849) and belt (part no. 1178179).

Table 39 – RGS072, 3 PHASE, 6 TON VERTICAL SUPPLY

CFM	AVAILABLE EXTERNAL STATIC PRESSURE (in. wg)									
	0.2		0.4		0.6		0.8		1.0	
	RPM	BHP	RPM	BHP	RPM	BHP	RPM	BHP	RPM	BHP
	Field-Supplied Drive¹		Standard Static Option						Medium Static Option	
1800	967	0.63	1075	0.80	1170	0.97	1255	1.13	1333	1.28
1950	1029	0.77	1132	0.96	1223	1.14	1306	1.32	1382	1.49
2100	1091	0.93	1189	1.14	1278	1.33	1358	1.52	1433	1.71
2250	1154	1.11	1248	1.33	1333	1.55	1411	1.75	1484	1.96
2400	1218	1.32	1308	1.55	1390	1.78	1466	2.01	1537	2.23
2550	1283	1.55	1369	1.80	1448	2.05	1521	2.29	1590	2.52
2700	1348	1.80	1431	2.07	1507	2.33	1578	2.59	1645	2.84
2850	1414	2.09	1493	2.37	1566	2.65	1636	2.92	1701	3.19
3000	1479	2.40	1556	2.70	1627	3.00	1694	3.29	1757	3.57

CFM	AVAILABLE EXTERNAL STATIC PRESSURE (in. wg)									
	1.2		1.4		1.6		1.8		2.0	
	RPM	BHP	RPM	BHP	RPM	BHP	RPM	BHP	RPM	BHP
	Medium Static Option						High Static Option			
1800	1406	1.43	1475	1.58	1540	1.72	1601	1.87	1660	2.00
1950	1454	1.65	1521	1.82	1585	1.98	1645	2.13	1703	2.29
2100	1502	1.89	1568	2.07	1631	2.25	1690	2.42	1747	2.59
2250	1552	2.15	1617	2.35	1678	2.54	1737	2.73	1793	2.92²
2400	1603	2.44	1666	2.65	1727	2.86	1784	3.06	1839	3.26
2550	1655	2.75	1717	2.98	1776	3.20	1833	3.42	1887	3.64
2700	1709	3.09	1769	3.33	1827	3.57	-	-	-	-
2850	1763	3.45	-	-	-	-	-	-	-	-

NOTE: For more information, see General Fan Performance Notes on page 46.

Boldface indicates field-supplied drive is required.

1. Recommend using field-supplied blower pulley (part no. 1175830), motor pulley (part no. 1175849) and belt (part no. 1178179).

2. Recommend using field-supplied blower pulley (part no. 1175314), motor pulley (part no. ?) and belt (part no. ?).

FAN PERFORMANCE (cont.)

Table 40 – RGS090 / 091, 3 PHASE, 7.5 TON HORIZONTAL SUPPLY

CFM	AVAILABLE EXTERNAL STATIC PRESSURE (in. wg)									
	0.2		0.4		0.6		0.8		1.0	
	RPM	BHP	RPM	BHP	RPM	BHP	RPM	BHP	RPM	BHP
Standard Static Option									Medium Static Option	
2250	505	0.52	586	0.73	657	0.97	722	1.22	782	1.50
2438	533	0.62	610	0.85	679	1.09	742	1.36	800	1.65
2625	562	0.74	635	0.98	701	1.23	762	1.51	819	1.81
2813	591	0.88	661	1.13	725	1.39	783	1.68	839	1.98
3000	621	1.03	688	1.29	749	1.57	806	1.87	859	2.18
3188	652	1.21	715	1.48	774	1.77	829	2.07	881	2.40
3375	682	1.40	743	1.68	800	1.98	853	2.30	903	2.63
3563	713	1.61	772	1.91	826	2.22	878	2.55	927	2.89
3750	745	1.85	801	2.15	853	2.48	903	2.82	951	3.18

CFM	AVAILABLE EXTERNAL STATIC PRESSURE (in. wg)									
	1.2		1.4		1.6		1.8		2.0	
	RPM	BHP	RPM	BHP	RPM	BHP	RPM	BHP	RPM	BHP
Medium Static Option						High Static Option				
2250	838	1.81	891	2.12	941	2.46	988	2.82	1033	3.19
2438	854	1.96	906	2.28	955	2.63	1001	2.99	1046	3.37
2625	872	2.12	922	2.46	970	2.81	1016	3.17	1060	3.56
2813	890	2.31	940	2.65	986	3.01	1031	3.38	1074	3.77
3000	910	2.51	958	2.86	1004	3.23	1048	3.61	1090	4.01
3188	930	2.74	977	3.10	1022	3.47	1065	3.86	1107	4.26¹
3375	951	2.99	997	3.35	1041	3.74	1083	4.13	1124	4.54
3563	973	3.26	1018	3.63	1061	4.02	1103	4.43	–	–
3750	996	3.55	1040	3.93	1082	4.34	–	–	–	–

NOTE: For more information, see General Fan Performance Notes on page 46.

Boldface indicates field-supplied drive is required.

¹ Recommend using field-supplied blower pulley (part no. 1175896), and belt (part no. 1178182).

Table 41 – RGS090 / 091, 3 PHASE, 7.5 TON VERTICAL SUPPLY

CFM	AVAILABLE EXTERNAL STATIC PRESSURE (in. wg)									
	0.2		0.4		0.6		0.8		1.0	
	RPM	BHP	RPM	BHP	RPM	BHP	RPM	BHP	RPM	BHP
Standard Static Option									Medium Static Option	
2250	513	0.54	595	0.76	665	1.01	728	1.27	786	1.56
2438	541	0.65	620	0.89	688	1.14	750	1.42	806	1.71
2625	570	0.77	645	1.02	712	1.29	772	1.58	827	1.88
2813	600	0.91	672	1.18	736	1.46	794	1.76	848	2.07
3000	629	1.07	699	1.35	761	1.64	818	1.95	871	2.28
3188	660	1.25	726	1.54	787	1.85	842	2.17	894	2.51
3375	690	1.45	754	1.75	813	2.07	867	2.41	917	2.76
3563	721	1.67	783	1.98	840	2.32	892	2.67	941	3.03
3750	752	1.91	812	2.24	867	2.59	918	2.95	966	3.32

CFM	AVAILABLE EXTERNAL STATIC PRESSURE (in. wg)									
	1.2		1.4		1.6		1.8		2.0	
	RPM	BHP	RPM	BHP	RPM	BHP	RPM	BHP	RPM	BHP
Medium Static Option						High Static Option				
2250	839	1.86	889	2.18	935	2.52	980	2.87	1022	3.23
2438	858	2.02	907	2.35	953	2.70	997	3.06	1039	3.43
2625	878	2.20	926	2.54	972	2.89	1015	3.26	1056	3.64
2813	899	2.40	946	2.75	991	3.11	1033	3.49	1074	3.88
3000	920	2.62	966	2.98	1010	3.35	1052	3.74	1093	4.14
3188	942	2.86	987	3.23	1031	3.61	1072	4.01	1112	4.42¹
3375	964	3.12	1009	3.50	1052	3.89	1093	4.30	–	–
3563	988	3.41	1032	3.80	1074	4.20	1114	4.61	–	–
3750	1011	3.71	1054	4.11	1096	4.53	–	–	–	–

NOTE: For more information, see General Fan Performance Notes on page 46.

Boldface indicates field-supplied drive is required.

¹ Recommend using field-supplied blower pulley (part no. 1175896), and belt (part no. 1178182).

FAN PERFORMANCE (cont.)

Table 42 – RGS101 / 102, 3 PHASE, 8.5 TON HORIZONTAL SUPPLY

CFM	AVAILABLE EXTERNAL STATIC PRESSURE (in. wg)									
	0.2		0.4		0.6		0.8		1.0	
	RPM	BHP	RPM	BHP	RPM	BHP	RPM	BHP	RPM	BHP
	Field-Supplied Drive¹		Standard Static Option						Medium Static Option	
2550	497	0.48	579	0.61	651	0.75	717	0.90	777	1.05
2763	524	0.58	602	0.72	671	0.87	735	1.03	794	1.19
2975	551	0.70	626	0.86	693	1.01	754	1.18	812	1.35
3188	580	0.84	651	1.00	716	1.17	775	1.34	831	1.52
3400	609	1.00	677	1.17	739	1.35	797	1.53	851	1.71
3613	638	1.17	703	1.35	763	1.54	819	1.73	871	1.93
3825	668	1.37	730	1.56	788	1.76	842	1.96	893	2.16
4038	698	1.59	758	1.79	813	2.00	866	2.20	915	2.42
4250	728	1.83	786	2.04	839	2.26	890	2.47	938	2.70

CFM	AVAILABLE EXTERNAL STATIC PRESSURE (in. wg)									
	1.2		1.4		1.6		1.8		2.0	
	RPM	BHP	RPM	BHP	RPM	BHP	RPM	BHP	RPM	BHP
	Medium Static Option					High Static Option				
2550	833	1.21	886	1.38	936	1.56	984	1.74	1029	1.93
2763	849	1.36	900	1.53	950	1.72	996	1.90	1041	2.10
2975	865	1.52	916	1.70	964	1.89	1010	2.09	1054	2.29
3188	883	1.70	933	1.89	980	2.09	1025	2.29	1068	2.50
3400	902	1.90	950	2.10	996	2.30	1041	2.51	1083	2.73
3613	921	2.13	969	2.33	1014	2.54	1057	2.76	1099	2.98²
3825	941	2.37	988	2.58	1032	2.80	1075	3.02	1116	3.25
4038	963	2.63	1008	2.86	1051	3.08	1093	3.31	1133	3.55
4250	984	2.92	1029	3.15	1071	3.39	1112	3.63	1152	3.87

NOTE: For more information, see General Fan Performance Notes on page 46.

Boldface indicates field-supplied drive is required.

¹ Recommend using field-supplied blower pulley (part no. 1178189), belt (part no. 1178450).

² Recommend using field-supplied motor pulley (part no. 1178133), fan pulley (part no. 1178596) belt (part no. 1178182)

Table 43 – RGS101 / 102, 3 PHASE, 8.5 TON VERTICAL SUPPLY

CFM	AVAILABLE EXTERNAL STATIC PRESSURE (in. wg)									
	0.2		0.4		0.6		0.8		1.0	
	RPM	BHP	RPM	BHP	RPM	BHP	RPM	BHP	RPM	BHP
	Standard Static Option						Medium Static Option			
2550	526	0.51	600	0.65	666	0.79	727	0.93	783	1.07
2763	557	0.62	627	0.77	690	0.92	749	1.08	804	1.23
2975	588	0.75	655	0.91	716	1.08	772	1.24	825	1.40
3188	621	0.90	684	1.07	743	1.25	797	1.42	848	1.60
3400	653	1.06	714	1.25	770	1.44	822	1.62	872	1.81
3613	687	1.25	744	1.45	798	1.65	849	1.84	897	2.04
3825	720	1.45	775	1.67	827	1.88	876	2.09	922	2.30
4038	754	1.69	807	1.91	856	2.13	904	2.35	949	2.57
4250	788	1.94	839	2.17	886	2.41	932	2.64	976	2.88

CFM	AVAILABLE EXTERNAL STATIC PRESSURE (in. wg)									
	1.2		1.4		1.6		1.8		2.0	
	RPM	BHP	RPM	BHP	RPM	BHP	RPM	BHP	RPM	BHP
	Medium Static Option					High Static Option				
2550	836	1.20	886	1.34	934	1.48	979	1.61	1022	1.74
2763	855	1.37	904	1.52	950	1.67	995	1.82	1037	1.97
2975	875	1.56	923	1.72	968	1.88	1012	2.04	1053	2.20
3188	897	1.77	943	1.94	987	2.11	1030	2.29	1071	2.46
3400	919	1.99	964	2.18	1007	2.36	1049	2.55	1089	2.73¹
3613	943	2.24	986	2.44	1029	2.63	1069	2.83	1108	3.02
3825	967	2.51	1010	2.71	1051	2.92	1090	3.13	1129	3.34
4038	992	2.80	1034	3.02	1074	3.24	1112	3.46	1150	3.68
4250	1018	3.11	1058	3.34	1097	3.57	-	-	-	-

NOTE: For more information, see General Fan Performance Notes on page 46.

Boldface indicates field-supplied drive is required.

¹ Recommend using field-supplied motor pulley (part number 1178133), fan pulley (part no. 1175896) and belt (part no. 1178182)

FAN PERFORMANCE (cont.)

Table 44 – RGS120 / 121, 3 PHASE, 10 TON HORIZONTAL SUPPLY

CFM	AVAILABLE EXTERNAL STATIC PRESSURE (in. wg)									
	0.2		0.4		0.6		0.8		1.0	
	RPM	BHP	RPM	BHP	RPM	BHP	RPM	BHP	RPM	BHP
	Field-Supplied Drive¹		Standard Static Option						Medium Static Option	
3000	579	0.70	660	0.89	732	1.09	799	1.29	860	1.50
3250	613	0.85	690	1.06	760	1.27	823	1.49	883	1.71
3500	648	1.03	721	1.25	788	1.48	850	1.71	907	1.95
3750	683	1.23	753	1.47	817	1.71	877	1.96	933	2.21
4000	719	1.45	786	1.71	848	1.97	905	2.23	959	2.50
4250	756	1.71	819	1.98	879	2.26	934	2.53	987	2.81
4500	792	1.99	853	2.28	910	2.57	964	2.87	1015	3.16
4750	830	2.31	888	2.62	943	2.92	995	3.23	1044	3.54
5000	867	2.66	923	2.98	976	3.30	1026	3.63	1074	3.95

CFM	AVAILABLE EXTERNAL STATIC PRESSURE (in. wg)									
	1.2		1.4		1.6		1.8		2.0	
	RPM	BHP	RPM	BHP	RPM	BHP	RPM	BHP	RPM	BHP
	Medium Static Option						High Static Option			
3000	917	1.70	970	1.91	1021	2.13	1070	2.34	1117	2.56
3250	938	1.93	991	2.16	1041	2.38	1089	2.61	1134	2.85
3500	961	2.18	1013	2.42	1062	2.66	1108	2.91	1153	3.15
3750	985	2.46	1035	2.71	1083	2.97	1129	3.23	1173	3.49
4000	1011	2.76	1059	3.03	1106	3.30	1151	3.58	1194	3.85
4250	1037	3.09	1084	3.38	1130	3.66	1174	3.95	1216	4.24
4500	1064	3.46	1110	3.76	1155	4.06	1198	4.36	1239	4.66
4750	1091	3.85	1137	4.16	1180	4.48	1222	4.80	-	-
5000	1120	4.28	1164	4.61	1207	4.94	-	-	-	-

NOTE: For more information, see General Fan Performance Notes on page 46.

Boldface indicates field-supplied drive is required.

¹ Recommend using field-supplied blower pulley (part no. 1178190), and belt (part no. 1178181).

Table 45 – RGS120 / 121, 3 PHASE, 10 TON VERTICAL SUPPLY

CFM	AVAILABLE EXTERNAL STATIC PRESSURE (in. wg)									
	0.2		0.4		0.6		0.8		1.0	
	RPM	BHP	RPM	BHP	RPM	BHP	RPM	BHP	RPM	BHP
	Standard Static Option						Medium Static Option			
3000	616	0.79	689	0.97	757	1.16	821	1.36	882	1.57
3250	655	0.96	724	1.16	788	1.37	849	1.58	907	1.80
3500	695	1.17	760	1.38	821	1.60	879	1.83	934	2.06
3750	736	1.41	797	1.63	855	1.86	910	2.10	963	2.35
4000	777	1.68	834	1.91	889	2.16	942	2.41	993	2.67
4250	818	1.98	873	2.23	925	2.49	976	2.75	1025	3.02
4500	860	2.32	912	2.58	962	2.85	1010	3.13	1057	3.41
4750	902	2.69	951	2.97	999	3.26	1046	3.55	1091	3.84
5000	944	3.11	991	3.40	1037	3.70	1082	4.00	1125	4.31

CFM	AVAILABLE EXTERNAL STATIC PRESSURE (in. wg)									
	1.2		1.4		1.6		1.8		2.0	
	RPM	BHP	RPM	BHP	RPM	BHP	RPM	BHP	RPM	BHP
	Medium Static Option						High Static Option			
3000	939	1.79	994	2.01	1047	2.24	1098	2.47	1147	2.71
3250	962	2.03	1015	2.26	1066	2.50	1115	2.75	1163	3.00
3500	987	2.30	1038	2.54	1088	2.80	1135	3.05	1181	3.32
3750	1014	2.60	1063	2.86	1111	3.12	1157	3.39	1202	3.66
4000	1042	2.93	1090	3.20	1136	3.48	1180	3.76	1224	4.04
4250	1072	3.30	1118	3.58	1162	3.87	1205	4.16	-	-
4500	1103	3.70	1147	4.00	1190	4.29	1232	4.60	-	-
4750	1135	4.14	1177	4.45	1219	4.76	-	-	-	-
5000	1167	4.63	1209	4.95	-	-	-	-	-	-

NOTE: For more information, see General Fan Performance Notes on page 46.

FAN PERFORMANCE (cont.)

Table 46 – RGS150, 3 PHASE, 12.5 TON HORIZONTAL SUPPLY

CFM	AVAILABLE EXTERNAL STATIC PRESSURE (in. wg)									
	0.2		0.4		0.6		0.8		1.0	
	RPM	BHP	RPM	BHP	RPM	BHP	RPM	BHP	RPM	BHP
	Standard Static Option					Medium Static Option				
3438	639	0.98	713	1.20	781	1.43	843	1.65	901	1.88
3750	683	1.23	753	1.47	817	1.71	877	1.96	933	2.21
4063	728	1.52	794	1.78	855	2.04	912	2.31	966	2.57
4375	774	1.85	836	2.13	894	2.41	949	2.70	1001	2.98
4688	820	2.23	879	2.53	935	2.83	987	3.14	1037	3.44
5000	867	2.66	923	2.98	976	3.30	1026	3.63	1074	3.95
5313	914	3.15	967	3.49	1018	3.83	1066	4.17	1112	4.52
5625	962	3.69	1012	4.05	1061	4.42	-	-	-	-
5938	1009	4.30	1058	4.68	-	-	-	-	-	-
6250	-	-	-	-	-	-	-	-	-	-

CFM	AVAILABLE EXTERNAL STATIC PRESSURE (in. wg)									
	1.2		1.4		1.6		1.8		2.0	
	RPM	BHP	RPM	BHP	RPM	BHP	RPM	BHP	RPM	BHP
	Medium Static Option					High Static Option				
3438	955	2.12	1007	2.35	1056	2.59	1103	2.83	1148	3.08
3750	985	2.46	1035	2.71	1083	2.97	1129	3.23	1173	3.49
4063	1017	2.84	1066	3.12	1112	3.39	1157	3.67	1200	3.95
4375	1050	3.27	1097	3.56	1142	3.86	1186	4.15	1228	4.45
4688	1084	3.75	1130	4.06	1174	4.37	1216	4.68	1257	5.00
5000	1120	4.28	1164	4.61	-	-	1248	5.27	1288	5.60
5313	-	-	-	-	-	-	-	-	-	-

NOTE: For more information, see General Fan Performance Notes on page 46.
Boldface indicates field-supplied drive is required.

Table 47 – RGS150, 3 PHASE, 12.5 TON VERTICAL SUPPLY

CFM	AVAILABLE EXTERNAL STATIC PRESSURE (in. wg)									
	0.2		0.4		0.6		0.8		1.0	
	RPM	BHP	RPM	BHP	RPM	BHP	RPM	BHP	RPM	BHP
	Standard Static Option					Medium Static Option				
3438	685	1.12	751	1.32	813	1.54	871	1.76	927	1.99
3750	736	1.41	797	1.63	855	1.86	910	2.10	963	2.35
4063	787	1.75	844	1.99	898	2.24	951	2.49	1001	2.75
4375	839	2.14	892	2.40	943	2.67	993	2.94	1041	3.21
4688	891	2.60	941	2.87	990	3.15	1037	3.44	1082	3.73
5000	944	3.11	991	3.40	1037	3.70	1082	4.00	1125	4.31
5313	997	3.69	1042	4.00	1085	4.32	1128	4.64	-	-
5625	1051	4.34	1093	4.67	-	-	-	-	-	-
5938	-	-	-	-	-	-	-	-	-	-
6250	-	-	-	-	-	-	-	-	-	-

CFM	AVAILABLE EXTERNAL STATIC PRESSURE (in. wg)									
	1.2		1.4		1.6		1.8		2.0	
	RPM	BHP	RPM	BHP	RPM	BHP	RPM	BHP	RPM	BHP
	Medium Static Option					High Static Option				
3438	981	2.23	1032	2.47	1082	2.72	1130	2.97	1177	3.23
3750	1014	2.60	1063	2.86	1111	3.12	1157	3.39	1202	3.66
4063	1049	3.02	1097	3.29	1142	3.57	1186	3.85	1230	4.14
4375	1087	3.49	1132	3.78	1176	4.08	1218	4.37	1260	4.68
4688	1126	4.03	1169	4.33	1211	4.64	-	-	-	-
5000	1167	4.63	-	-	-	-	-	-	-	-
5313	-	-	-	-	-	-	-	-	-	-
5625	-	-	-	-	-	-	-	-	-	-

NOTE: For more information, see General Fan Performance Notes on page 46.
Boldface indicates field-supplied drive is required.

FAN PERFORMANCE (cont.)

Table 48 – RGS180, 3 PHASE, 15 TON HORIZONTAL SUPPLY

CFM	Available External Static Pressure (in. wg)									
	0.2		0.4		0.6		0.8		1.0	
	RPM	BHP	RPM	BHP	RPM	BHP	RPM	BHP	RPM	BHP
4500	487	0.98	552	1.26	610	1.55	665	1.86	718	2.20
4875	515	1.18	578	1.49	633	1.80	685	2.13	735	2.47
5250	544	1.42	604	1.75	657	2.09	707	2.43	754	2.78
5625	572	1.68	631	2.05	682	2.40	730	2.76	775	3.13
6000	601	1.98	657	2.37	707	2.75	753	3.13	797	3.52
6375	630	2.31	684	2.73	733	3.13	777	3.53	819	3.94
6750	659	2.68	711	3.12	759	3.55	802	3.98	843	4.40
7125	689	3.09	739	3.55	785	4.01	827	4.46	867	4.91
7500	718	3.53	766	4.02	811	4.51	852	4.98	891	5.46

CFM	Available External Static Pressure (in. wg)									
	1.2		1.4		1.6		1.8		2.0	
	RPM	BHP	RPM	BHP	RPM	BHP	RPM	BHP	RPM	BHP
4500	769	2.56	819	2.95	866	3.36	912	3.79	957	4.24
4875	784	2.84	831	3.23	877	3.65	921	4.09	964	4.54
5250	800	3.16	845	3.56	889	3.98	932	4.43	974	4.89
5625	819	3.52	862	3.93	903	4.36	944	4.81	985	5.28
6000	839	3.92	880	4.34	920	4.77	959	5.23	997	5.70
6375	860	4.36	899	4.79	937	5.23	975	5.70	-----	-----
6750	882	4.84	920	5.28	957	5.74	-----	-----	-----	-----
7125	904	5.36	941	5.82	-----	-----	-----	-----	-----	-----
7500	928	5.93	-----	-----	-----	-----	-----	-----	-----	-----

NOTE: For more information, see General Fan Performance Notes on page 46.

Boldface indicates field supplied drive is required.

Table 49 – RGS180, 3 PHASE, 15 TON VERTICAL SUPPLY

CFM	Available External Static Pressure (in. wg)									
	0.2		0.4		0.6		0.8		1.0	
	RPM	BHP	RPM	BHP	RPM	BHP	RPM	BHP	RPM	BHP
4500	479	0.97	540	1.23	596	1.50	651	1.80	703	2.13
4875	508	1.19	566	1.47	619	1.75	670	2.06	719	2.39
5250	537	1.43	592	1.73	643	2.03	691	2.35	737	2.69
5625	566	1.71	619	2.03	667	2.35	713	2.68	757	3.03
6000	596	2.02	646	2.36	692	2.70	736	3.05	778	3.41
6375	625	2.36	674	2.73	718	3.09	760	3.46	800	3.83
6750	655	2.75	701	3.14	744	3.52	785	3.91	824	4.30
7125	685	3.17	729	3.58	771	3.99	810	4.40	848	4.81
7500	715	3.64	758	4.07	798	4.50	836	4.93	872	5.36

CFM	Available External Static Pressure (in. wg)									
	1.2		1.4		1.6		1.8		2.0	
	RPM	BHP	RPM	BHP	RPM	BHP	RPM	BHP	RPM	BHP
4500	755	2.48	805	2.87	853	3.28	900	3.72	945	4.17
4875	768	2.75	815	3.14	862	3.55	907	3.99	951	4.45
5250	783	3.06	828	3.45	872	3.86	916	4.30	958	4.77
5625	800	3.40	843	3.80	885	4.21	926	4.66	967	5.12
6000	819	3.79	860	4.19	900	4.61	939	5.06	978	5.53
6375	840	4.23	878	4.63	916	5.06	954	5.51	991	5.98
6750	861	4.70	898	5.12	935	5.56	971	6.01	-----	-----
7125	884	5.23	919	5.66	-----	-----	-----	-----	-----	-----
7500	907	5.79	-----	-----	-----	-----	-----	-----	-----	-----

NOTE: For more information, see General Fan Performance Notes on page 46.

Boldface indicates field supplied drive is required.

FAN PERFORMANCE (cont.)

Table 50 – PULLEY ADJUSTMENT

UNIT RGS		MOTOR/DRIVE COMBO	MOTOR PULLEY TURNS OPEN										
			0.0	0.5	1.0	1.5	2.0	2.5	3.0	3.5	4.0	4.5	5.0
036	1 phase	Standard Static	854	825	795	766	736	707	678	648	619	589	560
		Medium Static	1175	1135	1094	1054	1013	973	932	892	851	811	770
		High Static	-	-	-	-	-	-	-	-	-	-	-
	3 phase	Standard Static	854	825	795	766	736	707	678	648	619	589	560
		Medium Static	1175	1135	1094	1054	1013	973	932	892	851	811	770
		High Static	1466	1423	1380	1337	1294	1251	1207	1164	1121	1078	1035
048	1 phase	Standard Static	854	825	795	766	736	707	678	648	619	589	560
		Medium Static	1175	1135	1094	1054	1013	973	932	892	851	811	770
		High Static	-	-	-	-	-	-	-	-	-	-	-
	3 phase	Standard Static	854	825	795	766	736	707	678	648	619	589	560
		Medium Static	1175	1135	1094	1054	1013	973	932	892	851	811	770
		High Static	1466	1423	1380	1337	1294	1251	1207	1164	1121	1078	1035
060	1 phase	Standard Static	1175	1135	1094	1054	1013	973	932	892	851	811	770
		Medium Static	1466	1423	1380	1337	1294	1251	1207	1164	1121	1078	1035
		High Static	-	-	-	-	-	-	-	-	-	-	-
	3 phase	Standard Static	1175	1135	1094	1054	1013	973	932	892	851	811	770
		Medium Static	1466	1423	1380	1337	1294	1251	1207	1164	1121	1078	1035
		High Static	1687	1649	1610	1572	1533	1495	1457	1418	1380	1341	1303
072	3 phase	Standard Static	1457	1419	1380	1342	1303	1265	1227	1188	1150	1111	1073
		Medium Static	1518	1484	1449	1415	1380	1346	1311	1277	1242	1208	1173
		High Static	1788	1757	1725	1694	1662	1631	1600	1568	1537	1505	1474
090/091	3 phase	Standard Static	747	721	695	670	644	618	592	566	541	515	489
		Medium Static	949	927	906	884	863	841	819	798	776	755	733
		High Static	1102	1083	1063	1044	1025	1006	986	967	948	928	909
101/102	3 phase	Standard Static	733	712	690	669	647	626	604	583	561	540	518
		Medium Static	936	911	887	862	838	813	788	764	739	715	690
		High Static	1084	1059	1035	1010	986	961	936	912	887	863	838
120/121	3 phase	Standard Static	838	813	789	764	739	715	690	665	640	616	591
		Medium Static	1084	1059	1035	1010	986	961	936	912	887	863	838
		High Static	1240	1218	1196	1175	1153	1131	1109	1087	1066	1044	1022
150	3 phase	Standard Static	838	813	789	764	739	715	690	665	640	616	591
		Medium Static	1084	1059	1035	1010	986	961	936	912	887	863	838
		High Static	1240	1218	1196	1175	1153	1131	1109	1087	1066	1044	1022
180	3 phase	Standard Static	676	659	642	625	608	592	575	558	541	524	507
		Medium Static	851	829	806	784	761	739	717	694	672	649	627
		High Static	955	937	919	901	883	866	848	830	812	794	776

NOTE: Do not adjust pulley further than 5 turns open.

■ – Factory settings

ELECTRICAL INFORMATION

Table 51 – RGS036, 3 TONS

V-Ph-Hz	VOLTAGE RANGE		COMP (ea)		OFM (ea)		IFM		
	MIN	MAX	RLA	LRA	WATTS	FLA	TYPE	EFF at Full Load	FLA
208-1-60	187	253	16.6	79	325	1.5	Std Static	70%	4.9
							Med Static	70%	4.9
230-1-60	187	253	16.6	79	325	1.5	Std Static	70%	4.9
							Med Static	70%	4.9
208-3-60	187	253	10.4	73	325	1.5	Std Static	70%	4.9
							Med Static	70%	4.9
							High Static	80%	5.2
230-3-60	187	253	10.4	73	325	1.5	Std Static	70%	4.9
							Med Static	70%	4.9
							High Static	80%	5.2
460-3-60	414	506	5.8	38	325	0.8	Std Static	70%	2.1
							Med Static	70%	2.1
							High Static	80%	2.6
575-3-60	518	633	3.8	37	325	0.6	Std Static	71%	1.9
							Med Static	71%	1.9
							High Static	80%	2.0

Table 52 – RGS048, 4 TONS

V-Ph-Hz	VOLTAGE RANGE		COMP (ea)		OFM (ea)		IFM		
	MIN	MAX	RLA	LRA	WATTS	FLA	TYPE	EFF at Full Load	FLA
208-1-60	187	253	21.8	117	325	1.5	Std Static	70%	4.9
							Med Static	78%	7.0
230-1-60	187	253	21.8	117	325	1.5	Std Static	70%	4.9
							Med Static	78%	7.0
208-3-60	187	253	13.7	83	325	1.5	Std Static	70%	4.9
							Med Static	70%	4.9
							High Static	80%	5.2
230-3-60	187	253	13.7	83	325	1.5	Std Static	70%	4.9
							Med Static	70%	4.9
							High Static	80%	5.2
460-3-60	414	506	6.2	41	325	0.8	Std Static	70%	2.1
							Med Static	70%	2.1
							High Static	80%	2.6
575-3-60	518	633	4.8	37	325	0.6	Std Static	71%	1.9
							Med Static	71%	2.1
							High Static	80%	2.0

Table 53 – RGS060, 5 TONS

V-Ph-Hz	VOLTAGE RANGE		COMP (ea)		OFM (ea)		IFM		
	MIN	MAX	RLA	LRA	WATTS	FLA	TYPE	EFF at Full Load	FLA
208-1-60	187	253	26.2	134	325	1.5	Std Static	70%	4.9
							Med Static	78%	7.0
230-1-60	187	253	26.2	134	325	1.5	Std Static	70%	4.9
							Med Static	78%	7.0
208-3-60	187	253	15.6	110	325	1.5	Std Static	70%	4.9
							Med Static	80%	5.2
							High Static	81%	7.5
230-3-60	187	253	15.6	110	325	1.5	Std Static	70%	4.9
							Med Static	80%	5.2
							High Static	81%	7.5
460-3-60	414	506	7.7	52	325	0.8	Std Static	70%	2.1
							Med Static	80%	2.6
							High Static	81%	3.4
575-3-60	518	633	5.8	39	325	0.6	Std Static	71%	1.9
							Med Static	81%	2.0
							High Static	81%	2.8

ELECTRICAL INFORMATION (cont.)

Table 54 – RGS072, 6 TONS

V-Ph-Hz	VOLTAGE RANGE		COMP (ea)		OFM (ea)		IFM		
	MIN	MAX	RLA	LRA	WATTS	FLA	TYPE	EFF at Full Load	FLA
208-3-60	187	253	19.0	123	325	1.5	Std Static	80%	5.2
							Med Static	81%	7.5
							High Static	81%	7.5
230-3-60	187	253	19.0	123	325	1.5	Std Static	80%	5.2
							Med Static	81%	7.5
							High Static	81%	7.5
460-3-60	414	506	9.7	62	325	0.8	Std Static	80%	2.6
							Med Static	81%	3.4
							High Static	81%	4.4
575-3-60	518	633	7.4	50	325	0.6	Std Static	80%	2.0
							Med Static	81%	2.8
							High Static	81%	2.8

Table 55 – RGS091, 7.5 TONS – 1 Stage Cooling

V-Ph-Hz	VOLTAGE RANGE		COMP (ea)		OFM (ea)		IFM		
	MIN	MAX	RLA	LRA	WATTS	FLA	TYPE	EFF at Full Load	FLA
208-3-60	187	253	25.0	164	325	1.5	Std Static	80%	5.2
							Med Static	81%	7.5
							High Static	81%	15.0
230-3-60	187	253	25.0	164	325	1.5	Std Static	80%	5.2
							Med Static	81%	7.5
							High Static	81%	15.0
460-3-60	414	506	12.2	100	325	0.8	Std Static	80%	2.6
							Med Static	81%	3.4
							High Static	81%	7.4
575-3-60	518	633	9.0	78	325	0.6	Std Static	80%	2.4
							Med Static	81%	2.8
							High Static	81%	5.6

Table 56 – RGS090, 7.5 TONS – 2 Stage Cooling

V-Ph-Hz	VOLTAGE RANGE		COMP (Cir 1)		COMP (Cir 2)		OFM (ea)		IFM		
	MIN	MAX	RLA	LRA	RLA	LRA	WATTS	FLA	TYPE	EFF at Full Load	FLA
208-3-60	187	253	13.6	83	13.6	83	325	1.5	STD	80%	5.2
									MED	81%	7.5
									HIGH	81%	15.0
230-3-60	187	253	13.6	83	13.6	83	325	1.5	STD	80%	5.2
									MED	81%	7.5
									HIGH	81%	15.0
460-3-60	414	506	6.1	41	6.1	41	325	0.8	STD	80%	2.6
									MED	81%	3.4
									HIGH	81%	7.4
575-3-60	518	633	4.2	33	4.2	33	325	0.6	STD	80%	2.4
									MED	81%	2.8
									HIGH	81%	5.6

ELECTRICAL INFORMATION (cont.)

Table 57 – RGS101, 8.5 TONS – 1 Stage Cooling

V-Ph-Hz	VOLTAGE RANGE		COMP (ea)		OFM (ea)		IFM		
	MIN	MAX	RLA	LRA	WATTS	FLA	TYPE	EFF at Full Load	FLA
208-3-60	187	253	29.5	195	325	1.5	Std Static	80%	5.2
							Med Static	80%	5.2
							High Static	80%	10.0
230-3-60	187	253	29.5	195	325	1.5	Std Static	80%	5.2
							Med Static	80%	5.2
							High Static	80%	10.0
460-3-60	414	506	14.7	95	325	0.8	Std Static	80%	2.6
							Med Static	80%	2.6
							High Static	80%	4.4
575-3-60	518	633	12.2	80	325	0.6	Std Static	80%	2.4
							Med Static	80%	2.0
							High Static	81%	2.8

Table 58 – RGS102, 8.5 TONS – 2 Stage Cooling

V-Ph-Hz	VOLTAGE RANGE		COMP (Cir 1)		COMP (Cir 2)		OFM (ea)		IFM		
	MIN	MAX	RLA	LRA	RLA	LRA	WATTS	FLA	TYPE	EFF at Full Load	FLA
208-3-60	187	253	14.5	98	13.7	83	325	1.5	STD	80%	5.2
									MED	80%	5.2
									HIGH	80%	10.0
230-3-60	187	253	14.5	98	13.7	83	325	1.5	STD	80%	5.2
									MED	80%	5.2
									HIGH	80%	10.0
460-3-60	414	506	6.3	55	6.2	41	325	0.8	STD	80%	2.6
									MED	80%	2.6
									HIGH	80%	4.4
575-3-60	518	633	6.0	41	4.8	33	325	0.6	STD	80%	2.4
									MED	80%	2.0
									HIGH	81%	2.8

Table 59 – RGS121, 10 TONS – 1 Stage Cooling

V-Ph-Hz	VOLTAGE RANGE		COMP (ea)		OFM (ea)		IFM		
	MIN	MAX	RLA	LRA	WATTS	FLA	TYPE	EFF at Full Load	FLA
208-3-60	187	253	30.1	225	325	1.5	Std Static	80%	5.2
							Med Static	81%	10.0
							High Static	81%	15.0
230-3-60	187	253	30.1	225	325	1.5	Std Static	80%	5.2
							Med Static	81%	10.0
							High Static	81%	15.0
460-3-60	414	506	16.7	114	325	0.8	Std Static	80%	2.6
							Med Static	81%	4.4
							High Static	81%	7.4
575-3-60	518	633	12.2	80	325	0.6	Std Static	80%	2.0
							Med Static	81%	2.8
							High Static	81%	5.6

ELECTRICAL INFORMATION (cont.)

Table 60 – RGS120, 10 TONS – 2 Stage Cooling

V-Ph-Hz	VOLTAGE RANGE		COMP (Cir 1)		COMP (Cir 2)		OFM (ea)		IFM		
	MIN	MAX	RLA	LRA	RLA	LRA	WATTS	FLA	TYPE	EFF at Full Load	FLA
208-3-60	187	253	15.6	110	15.9	110	325	1.5	STD	80%	5.2
									MED	81%	10.0
									HIGH	81%	15.0
230-3-60	187	253	15.6	110	15.9	110	325	1.5	STD	80%	5.2
									MED	81%	10.0
									HIGH	81%	15.0
460-3-60	414	506	7.7	52	7.7	52	325	0.8	STD	80%	2.6
									MED	81%	4.4
									HIGH	81%	7.4
575-3-60	518	633	5.8	39	5.7	39	325	0.6	STD	80%	2.0
									MED	81%	2.8
									HIGH	81%	5.6

Table 61 – RGS150, 12.5 TONS – 2 Stage Cooling

V-Ph-Hz	VOLTAGE RANGE		COMP (Cir 1)		COMP (Cir 2)		OFM (ea)		IFM		
	MIN	MAX	RLA	LRA	RLA	LRA	WATTS	FLA	TYPE	EFF at Full Load	FLA
208-3-60	187	253	19.0	123	22.4	149	1288	6.2	STD	81%	7.5
									MED	81%	10.0
									HIGH	81%	15.0
230-3-60	187	253	19.0	123	22.4	149	1288	6.2	STD	81%	7.5
									MED	81%	10.0
									HIGH	81%	15.0
460-3-60	414	506	9.7	62	10.6	75	1288	3.1	STD	81%	3.4
									MED	81%	4.4
									HIGH	81%	7.4
575-3-60	518	633	7.4	50	7.7	54	1288	2.5	STD	81%	2.8
									MED	81%	2.8
									HIGH	81%	5.6

Table 62 – RGS180, 15 TONS – 2 Stage Cooling

V-Ph-Hz	VOLTAGE RANGE		COMP (Cir 1)		COMP (Cir 2)		OFM (ea)		IFM		
	MIN	MAX	RLA	LRA	RLA	LRA	WATTS	FLA	TYPE	EFF at Full Load	FLA
208-3-60	187	253	25.0	164	25.0	164	1288	1.5	STD	81%	7.5
									MED	81%	10.0
									High High Efficiency	89.5%	20.4
230-3-60	187	253	25.0	164	25.0	164	1288	1.5	STD	81%	7.5
									MED	81%	10.0
									HIGH	81%	15.0
									High High Efficiency	89.5%	20.4
460-3-60	414	506	12.2	100	12.8	100	1288	0.8	STD	81%	3.4
									MED	81%	4.4
									High High Efficiency	89.5%	10.2
575-3-60	518	633	9.8	78	9.6	78	1288	0.6	STD	81%	2.8
									MED	81%	2.8
									High High Efficiency	89.5%	9.0

Table 63 – MCA/MOCP DETERMINATION NO C.O. OR UNPWRD C.O.

Unit	NOM. V-Ph-Hz	IFM TYPE	Combustion Fan Motor FLA	Power Exhaust FLA	NO C.O. or UNPWRD C.O.							
					NO P.E.				w/ P.E. (pwrd fr/ unit)			
					MCA	MOCP	DISC. SIZE		MCA	MOCP	DISC. SIZE	
							FLA	LRA			FLA	LRA
RGS036	208/230-1-60	STD	0.48	1.9	27.2	40.0	26	95	29.1	45.0	29	97
		MED			27.2	40.0	26	95	29.1	45.0	29	97
	208/230-3-60	STD	0.48	1.9	19.4	25.0	19	89	21.3	30.0	22	91
		MED			19.4	25.0	19	89	21.3	30.0	22	91
		HIGH			19.7	30.0	20	107	21.6	30.0	22	109
	460-3-60	STD	0.25	1.0	10.2	15.0	10	46	11.2	15.0	11	47
		MED			10.2	15.0	10	46	11.2	15.0	11	47
		HIGH			10.7	15.0	11	55	11.7	15.0	12	56
	575-3-60	STD	0.24	1.9	7.3	15.0	7	44	9.2	15.0	9	46
		MED			7.3	15.0	7	44	9.2	15.0	9	46
		HIGH			7.4	15.0	7	50	9.3	15.0	10	52
	RGS048	208/230-1-60	STD	0.48	1.9	33.7	50.0	32	133	35.6	50.0	35
MED			33.7			50.0	32	133	35.6	50.0	35	135
208/230-3-60		STD	0.48	1.9	23.5	30.0	23	99	25.4	30.0	25	101
		MED			23.5	30.0	23	99	25.4	30.0	25	101
		HIGH			23.8	30.0	23	117	25.7	30.0	25	119
460-3-60		STD	0.25	1.0	10.7	15.0	10	49	11.7	15.0	12	50
		MED			10.7	15.0	10	49	11.7	15.0	12	50
		HIGH			11.2	15.0	11	58	12.2	15.0	12	59
575-3-60		STD	0.24	1.9	8.5	15.0	8	44	10.4	15.0	11	46
		MED			8.5	15.0	8	44	10.4	15.0	11	46
		HIGH			8.6	15.0	9	50	10.5	15.0	11	52
RGS060		208/230-1-60	STD	0.48	1.9	39.2	60.0	37	150	41.1	60.0	40
	MED		41.3			60.0	40	175	43.2	60.0	42	177
	208/230-3-60	STD	0.48	1.9	25.9	30.0	25	126	27.8	40.0	27	128
		MED			26.2	40.0	26	144	28.1	40.0	28	146
		HIGH			28.5	40.0	29	170	30.4	45.0	30	172
	460-3-60	STD	0.25	1.0	12.5	20.0	12	60	13.5	20.0	13	61
		MED			13.0	20.0	13	69	14.0	20.0	14	70
		HIGH			13.8	20.0	14	82	14.8	20.0	15	83
	575-3-60	STD	0.24	1.9	9.8	15.0	10	46	11.7	15.0	12	48
		MED			9.9	15.0	10	52	11.8	15.0	13	54
		HIGH			10.7	15.0	11	63	12.6	15.0	13	65
	RGS072	208/230-3-60	STD	0.48	1.9	30.5	45.0	30	157	32.4	50.0	32
MED			32.8			50.0	32	183	34.7	50.0	34	185
HIGH			32.8			50.0	32	183	34.7	50.0	34	185
460-3-60		STD	0.25	1.0	15.5	25.0	15	79	16.5	25.0	16	80
		MED			16.3	25.0	16	92	17.3	25.0	17	93
		HIGH			17.3	25.0	17	101	18.3	25.0	18	102
575-3-60	STD	0.24	1.9	11.9	15.0	12	63	13.8	20.0	14	65	
	MED			12.7	20.0	12	74	14.6	20.0	15	76	
HIGH	12.7	20.0	12	74	14.6	20.0	15	76				
RGS091	208/230-3-60	STD	0.48	3.8	39.5	60	38	191	43.3	60	43	195
		MED			41.8	60	41	228	45.6	60	45	232
		HIGH			49.3	60	49	254	53.1	60	54	258
	460-3-60	STD	0.25	1.8	19.5	30	19	113	21.3	30	21	115
		MED			20.3	30	20	132	22.1	30	22	134
		HIGH			24.3	30	24	145	26.1	30	26	147
575-3-60	STD	0.24	3.8	14.9	20	14	89	18.7	25	19	93	
	MED			15.3	20	15	104	19.1	25	19	108	
HIGH	18.1	25	18	118	21.9	30	23	122				

See notes on next page 67.

Table 63 (cont.) MCA/MOCP DETERMINATION NO C.O. OR UNPWRD C.O.

Unit	NOM. V-Ph-Hz	IFM TYPE	Combustion Fan Motor FLA	Power Exhaust FLA	NO C.O. or UNPWRD C.O.				NO C.O. or UNPWRD C.O.			
					NO P.E.				w/ P.E. (pwrdr fr/ unit)			
					MCA	MOCP	DISC. SIZE		MCA	MOCP	DISC. SIZE	
							FLA	LRA			FLA	LRA
RGS090	208/230-3-60	STD	0.48	3.8	38.8	50	41	193	42.6	50	45	197
		MED			41.1	50	43	230	44.9	50	48	234
		HIGH			49.0	60	52	256	52.8	60	56	260
	460-3-60	STD	0.25	1.8	17.9	20	19	95	19.7	25	21	97
		MED			18.7	25	20	114	20.5	25	22	116
		HIGH			23.1	30	24	127	24.9	30	26	129
	575-3-60	STD	0.24	3.8	13.1	15	14	77	16.9	20	18	81
		MED			13.5	15	14	92	17.3	20	19	96
		HIGH			16.6	20	17	106	20.4	25	22	110
RGS101	208/230-3-60	STD	0.48	3.8	45.1	60	43	222	48.9	60	48	226
		MED			45.1	60	43	233	48.9	60	48	237
		HIGH			49.9	60	49	276	53.7	80	53	280
	460-3-60	STD	0.25	1.8	22.6	30	22	108	24.4	30	24	110
		MED			22.6	30	22	114	24.4	30	24	116
		HIGH			24.4	30	24	136	26.2	30	26	138
	575-3-60	STD	0.24	3.8	18.9	30	18	91	22.7	30	23	95
		MED			18.5	30	18	95	22.3	30	22	99
		HIGH			19.3	30	19	106	23.1	30	23	110
RGS102	208/230-3-60	STD	0.48	3.8	40.0	50	42	208	43.8	50	46	212
		MED			40.0	50	42	219	43.8	50	46	223
		HIGH			44.8	50	47	262	48.6	60	52	266
	460-3-60	STD	0.25	1.8	18.3	20	19	109	20.1	25	21	111
		MED			18.3	20	19	115	20.1	25	21	117
		HIGH			20.1	25	21	137	21.9	25	23	139
	575-3-60	STD	0.24	3.8	15.9	20	17	85	19.7	25	21	89
		MED			15.5	20	16	89	19.3	25	20	93
		HIGH			16.3	20	17	100	20.1	25	21	104
RGS121	208/230-3-60	STD	0.48	3.8	45.8	60	44	263	49.6	60	48	267
		MED			50.6	60	50	306	54.4	80	54	310
		HIGH			55.6	80	55	315	59.4	80	60	319
	460-3-60	STD	0.25	1.8	25.1	30	24	133	26.9	40	26	135
		MED			26.9	40	26	155	28.7	45	28	157
		HIGH			29.9	45	30	159	31.7	45	32	161
	575-3-60	STD	0.24	3.8	18.5	30	18	95	22.3	30	22	99
		MED			19.3	30	19	106	23.1	30	23	110
		HIGH			22.1	30	22	120	25.9	30	26	124
RGS120	208/230-3-60	STD	0.48	3.8	43.7	50	46	258	47.5	60	50	262
		MED			48.5	60	51	301	52.3	60	56	305
		HIGH			53.5	60	57	310	57.3	70	61	314
	460-3-60	STD	0.25	1.8	21.5	25	23	123	23.3	30	25	125
		MED			23.3	30	25	145	25.1	30	27	147
		HIGH			26.3	30	28	149	28.1	35	30	151
	575-3-60	STD	0.24	3.8	16.2	20	17	93	20.0	25	21	97
		MED			17.0	20	18	104	20.8	25	22	108
		HIGH			19.8	25	21	118	23.6	30	25	122
RGS150	208/230-3-60	STD	0.48	3.8	60.7	80	63	360	64.5	80	68	364
		MED			63.2	80	66	377	67.0	80	71	381
		HIGH			68.2	80	72	386	72.0	80	76	390
	460-3-60	STD	0.25	1.8	29.5	40	31	181	31.3	40	33	183
		MED			30.5	40	32	190	32.3	40	34	192
		HIGH			33.5	40	35	194	35.3	45	37	196
	575-3-60	STD	0.24	3.8	22.3	30	23	142	26.1	30	28	146
		MED			22.3	30	23	142	26.1	30	28	146
		HIGH			25.1	30	27	156	28.9	35	31	100
RGS180	208/230-3-60	STD	0.48	3.8	68.3	80	71	396	72.1	80	76	400
		MED			70.8	80	74	413	74.6	90	79	417
		High High Eff.			81.2	100	86	432	85.0	100	91	436
	460-3-60	STD	0.25	1.8	34.0	45	35	234	35.8	45	37	236
		MED			35.0	45	37	243	36.8	45	39	245
		High High Eff.			40.8	50	43	252	42.6	50	45	254
	575-3-60	STD	0.24	3.8	26.5	30	28	184	30.3	40	32	188
		MED			26.5	30	28	184	30.3	40	32	188
		High High Eff.			32.7	40	35	196	36.5	45	39	200

See notes on next page 67.

LEGEND:

- CO - Convenient outlet
- DISC - Disconnect
- FLA - Full load amps
- IFM - Indoor fan motor
- LRA - Locked rotor amps
- MCA - Minimum circuit amps
- MOCP - Maximum over current protection
- PE - Power exhaust
- UNPWRD CO - Unpowered convenient outlet



NOTES:

1. In compliance with NEC requirements for multimotor and combination load equipment (refer to NEC Articles 430 and 440), the overcurrent protective device for the unit shall be fuse or HACR breaker. Canadian units may be fuse or circuit breaker.

2. Unbalanced 3-Phase Supply Voltage

Never operate a motor where a phase imbalance in supply voltage is greater than 2%. Use the following formula to determine the percentage of voltage imbalance.

$$\% \text{ Voltage Imbalance} = 100 \times \frac{\text{max voltage deviation from average voltage}}{\text{average voltage}}$$

Example: Supply voltage is 230-3-60



- AB = 224 v
- BC = 231 v
- AC = 226 v

$$\begin{aligned} \text{Average Voltage} &= \frac{(224 + 231 + 226)}{3} = \frac{681}{3} \\ &= 227 \end{aligned}$$

Determine maximum deviation from average voltage.

(AB) $227 - 224 = 3 \text{ v}$

(BC) $231 - 227 = 4 \text{ v}$

(AC) $227 - 226 = 1 \text{ v}$

Maximum deviation is 4 v.

Determine percent of voltage imbalance.

$$\begin{aligned} \% \text{ Voltage Imbalance} &= 100 \times \frac{4}{227} \\ &= 1.76\% \end{aligned}$$

This amount of phase imbalance is satisfactory as it is below the maximum allowable 2%.

IMPORTANT: If the supply voltage phase imbalance is more than 2%, contact your local electric utility company immediately.

Fig. 8 Typical Power Diagram – 1 Stage Cooling

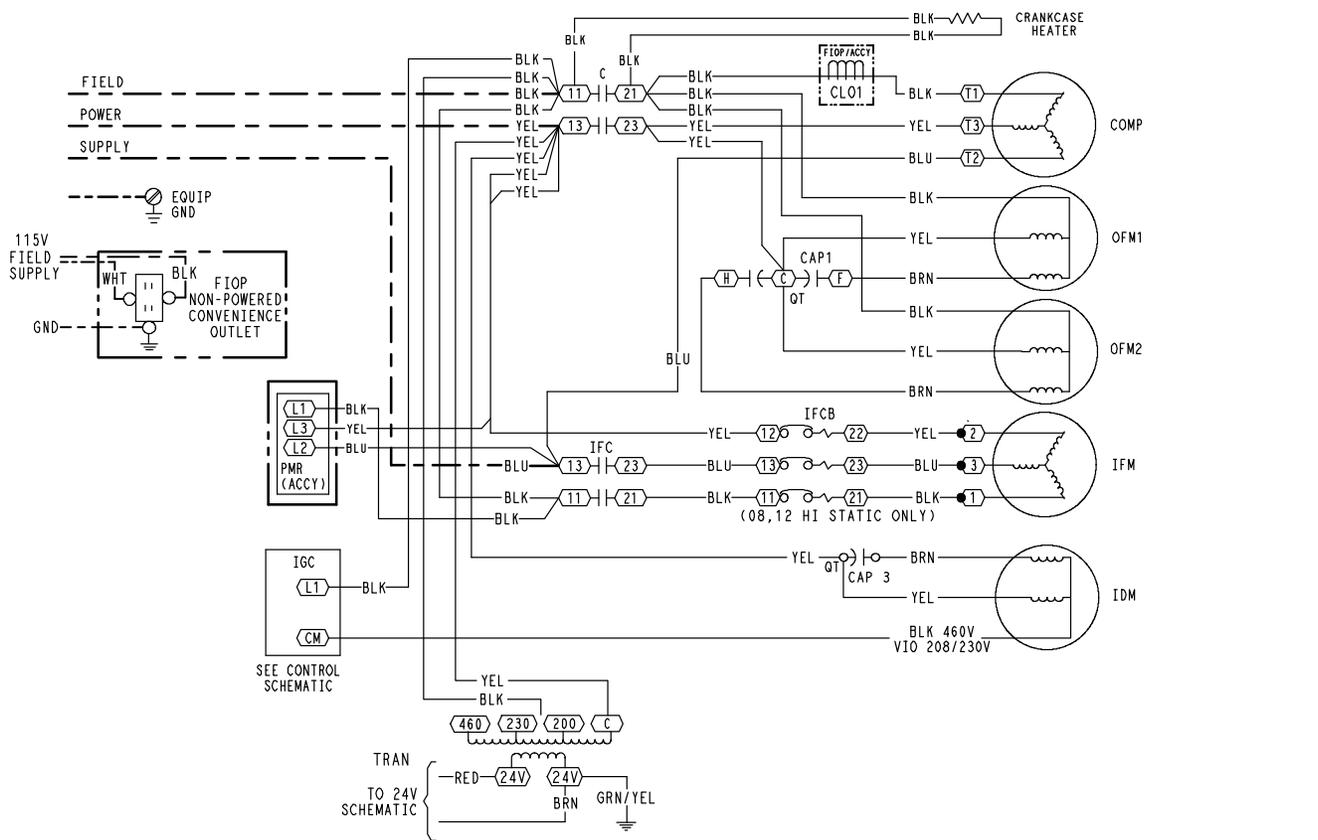

LEGEND

- X MARKED WIRE
- X TERMINAL (MARKED)
- O TERMINAL (UNMARKED)
- X TERMINAL BLOCK
- SPLICE
- SPLICE (MARKED)
- FACTORY WIRING
- - - FIELD CONTROL WIRING
- - - - FIELD POWER WIRING
- - - - - CIRCUIT BOARD TRACE
- ACCESSORY OR OPTIONAL WIRING
- TO INDICATE COMMON POTENTIAL ONLY: NOT TO REPRESENT WIRING

C	CONTACTOR, COMPRESSOR	OAO	OUTDOOR AIR QUALITY
CAP	CAPACITOR	OAT	OUTDOOR AIR TEMP. SEN
CB	CIRCUIT BREAKER	OFM	OUTDOOR FAN MOTOR
CCH	CRANKCASE HEATER	OL	OVERLOAD
CMP SAFE	COMPRESSOR SAFETY	PL	PLUG ASSEMBLY
COMP	COMPRESSOR MOTOR	POT	POTENTIOMETER
DDC	DIRECT DIGITAL CONTROL	PMR	PHASE MONITOR RELAY
FSD	FIRE SHUT DOWN	QT	QUADRUPLE TERMINAL
FU	FUSE	R	RELAY
GND	GROUND	RAT	RETURN AIR TEMP. SEN
GVR	GAS VALVE RELAY	RMT OCC	REMOTE OCCUPANCY
HPS	HIGH PRESSURE SWITCH	RS	ROLLOUT SWITCH
HS	HALL EFFECT SENSOR	SAT	SUPPLY AIR TEMP. SENSOR
I	IGNITOR	SEN	SENSOR
IAQ	INDOOR AIR QUALITY SENSORS	SET	SET POINT OFFSET
IFC	INDOOR FAN CONTACTOR	SFS	SUPPLY FAN STATUS
IFCB	INDOOR FAN CIRCUIT BREAKER	TDR	TIME DELAY RELAY
IFM	INDOOR FAN MOTOR	TRAN	TRANSFORMER
IGC	INTEGRATED GAS CONTROL		
IRH	INDOOR RELATIVE HUMIDITY		
LA	LOW AMBIENT LOCKOUT		
LOOP PWR	CURRENT LOOP POWER		
LPS	LOW PRESSURE SWITCH		
LSM	LIMIT SWITCH (MANUAL RESET)		
MGV	MAIN GAS VALVE		

NOTES

1. IF ANY OF THE ORIGINAL WIRE FURNISHED MUST BE REPLACED, IT MUST BE REPLACED WITH TYPE 90 C WIRE OR ITS EQUIVALENT.
2. COMPRESSOR AND FAN MOTORS ARE THERMALLY PROTECTED. THREE PHASE MOTORS ARE PROTECTED AGAINST PRIMARY SINGLE PHASING CONDITIONS.
3. 208/230V UNIT TRAN IS WIRED FOR 230V UNIT. IF UNIT IS TO BE RUN WITH 208V POWER SUPPLY DISCONNECT BLK WIRE FROM 230V TAP AND CONNECT TO 200V TAP.
4. USE COPPER, COPPER CLAD, ALUMINUM OR ALUMINUM CONNECTORS.
5. USE COPPER CONDUCTOR ONLY.

C08518

Fig. 9 Typical Power Diagram – 2 Stage Cooling

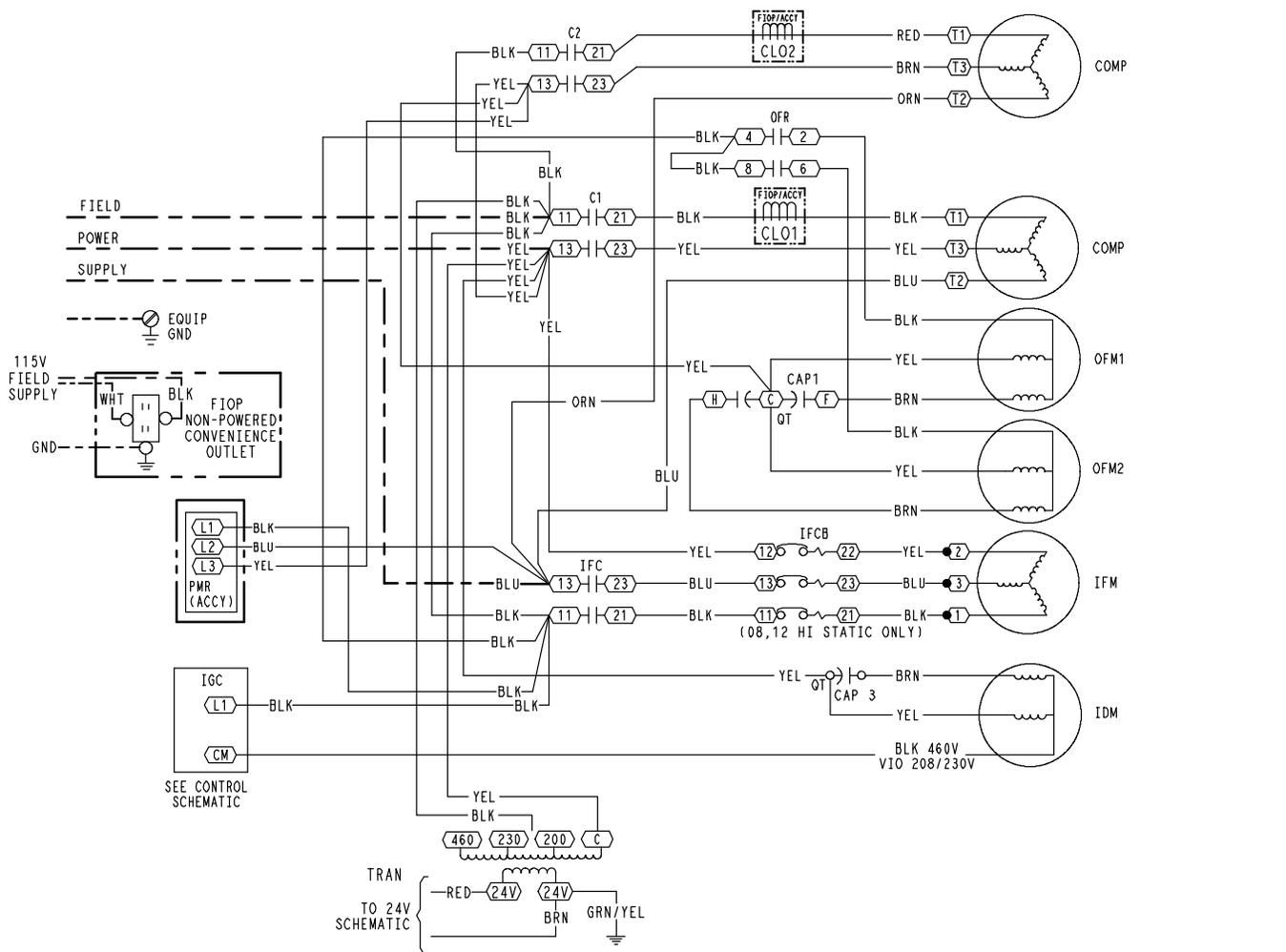

LEGEND

- X MARKED WIRE
- X TERMINAL (MARKED)
- TERMINAL (UNMARKED)
- Y TERMINAL BLOCK
- SPLICE
- SPLICE (MARKED)
- FACTORY WIRING
- FIELD CONTROL WIRING
- FIELD POWER WIRING
- CIRCUIT BOARD TRACE
- ACCESSORY OR OPTIONAL WIRING
- TO INDICATE COMMON POTENTIAL ONLY: NOT TO REPRESENT WIRING

NOTES

1. IF ANY OF THE ORIGINAL WIRE FURNISHED MUST BE REPLACED, IT MUST BE REPLACED WITH TYPE 90 C WIRE OR ITS EQUIVALENT.
2. COMPRESSOR AND FAN MOTORS ARE THERMALLY PROTECTED. THREE PHASE MOTORS ARE PROTECTED AGAINST PRIMARY SINGLE PHASING CONDITIONS.
3. 208/230V UNIT TRAN IS WIRED FOR 230V UNIT. IF UNIT IS TO BE RUN WITH 208V POWER SUPPLY DISCONNECT BLK WIRE FROM 230V TAP AND CONNECT TO 200V TAP.
4. USE COPPER, COPPER CLAD, ALUMINUM OR ALUMINUM CONNECTORS.
5. USE COPPER CONDUCTOR ONLY.

C	CONTACTOR, COMPRESSOR	OAQ	OUTDOOR AIR QUALITY
CAP	CAPACITOR	OAT	OUTDOOR AIR TEMP. SEN
CB	CIRCUIT BREAKER	OFM	OUTDOOR FAN MOTOR
CCH	CRANKCASE HEATER	OL	OVERLOAD
CMP SAFE	COMPRESSOR SAFETY	PL	PLUG ASSEMBLY
CLO	COMPRESSOR LOCKOUT	POT	POTENTIOMETER
COMP	COMPRESSOR MOTOR	PMR	PHASE MONITOR RELAY
DDC	DIRECT DIGITAL CONTROL	QT	QUADRUPLE TERMINAL
FSD	FIRE SHUT DOWN	R	RELAY
FS	FLAME SENSOR	RAT	RETURN AIR TEMP. SEN
FU	FUSE	RMT OCC	REMOTE OCCUPANCY
GND	GROUND	RS	ROLLOUT SWITCH
GVR	GAS VALVE RELAY	SAT	SUPPLY AIR TEMP. SENSOR
HPS	HIGH PRESSURE SWITCH	SEN	SENSOR
HS	HALL EFFECT SENSOR	SET	SET POINT OFFSET
I	IGNITOR	SFS	SUPPLY FAN STATUS
IAQ	INDOOR AIR QUALITY SENSORS	TDR	TIME DELAY RELAY
IDM	INDUCED DRAFT MOTOR	TRAN	TRANSFORMER
IFC	INDOOR FAN CONTACTOR		
IFCB	INDOOR FAN CIRCUIT BREAKER		
IFM	INDOOR FAN MOTOR		
IGC	INTEGRATED GAS CONTROL		
IRH	INDOOR RELATIVE HUMIDITY		
JMP	JUMPER		
LA	LOW AMBIENT LOCKOUT		
LOOP PWR	CURRENT LOOP POWER		
LPS	LOW PRESSURE SWITCH		
LSM	LIMIT SWITCH (MANUAL RESET)		
LS	LIMIT SWITCH		
MGV	MAIN GAS VALVE		
OFR	OUTDOOR FAN RELAY		

C08577

Fig. 11 Typical Wiring Diagram - 2 Stage Cooling

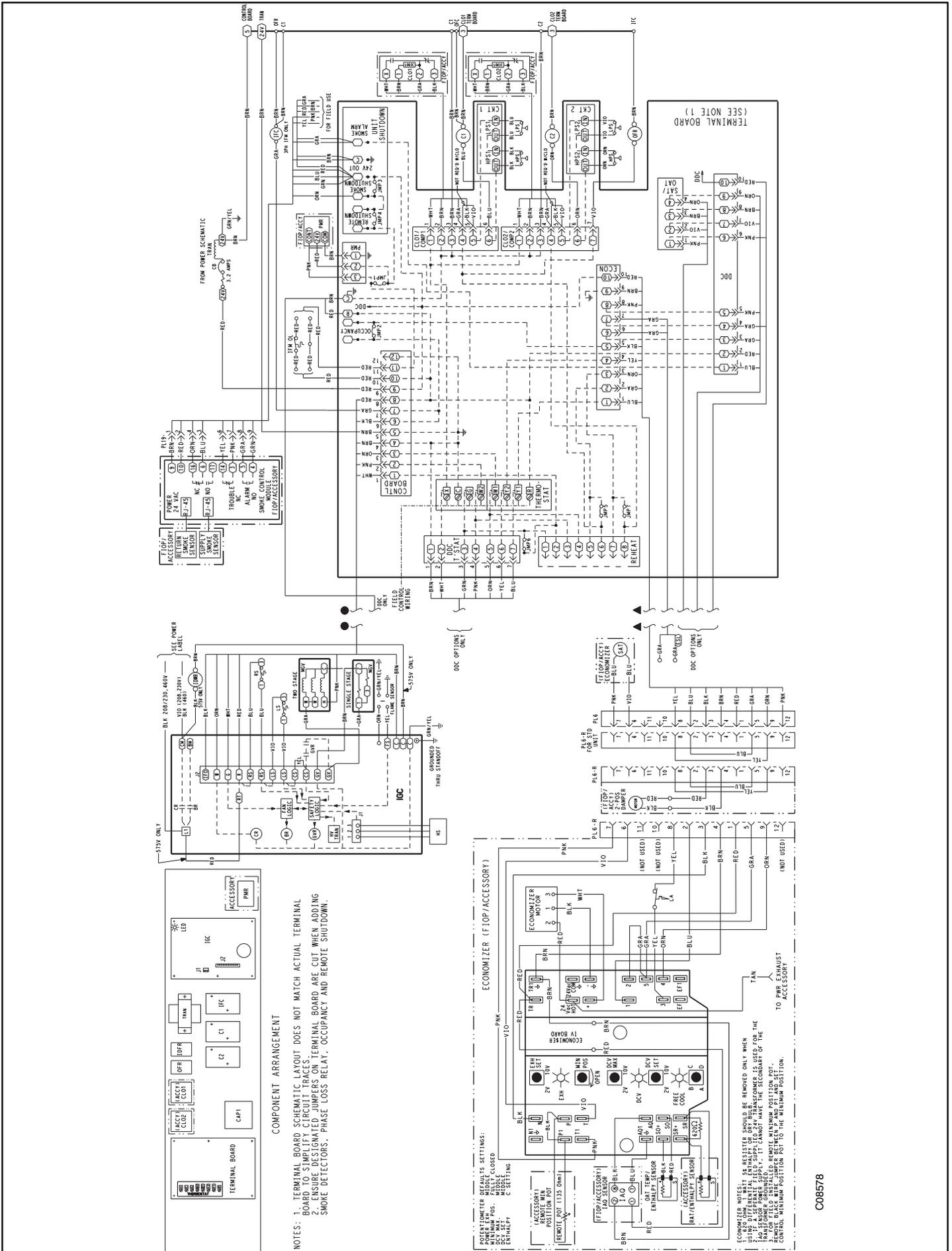

SEQUENCE OF OPERATION

General

The sequence below describes the sequence of operation for an electro-mechanical unit with and without a factory installed economizer. For information regarding a direct digital controller, see the start-up, operations, and troubleshooting manual for the applicable controller.

Units with no Economizer

Cooling —

When the thermostat calls for cooling, terminals G and Y1 are energized. As a result, the indoor-fan contactor (IFC) and the compressor contactor (C1) are energized, causing the indoor-fan motor (IFM), compressor #1, and outdoor fan to start. The outdoor-fan motor runs continuously while unit is cooling.

Heating

NOTE: RGS units have either 1 or 2 stages of gas heat.

When the thermostat calls for heating, power is sent to W on the Integrated Gas Controller (IGC) board. An LED (light-emitting diode) on the IGC board turns on and remains on during normal operation. A check is made to ensure that the rollout switch and limit switch are closed and the induced-draft motor is running. If the check was successful, the induced-draft motor is energized, and when its speed is satisfactory, as proven by the "hall effect" sensor, the ignition activation period begins. The burners will ignite within 5 seconds. If the burners do not light, there is a 22-second delay before another 5-second attempt. This sequence is repeated for 15 minutes or until the burners light. If, after the 15 minutes, the burners still have not lit, heating is locked out. To reset the control, break 24-v power to the thermostat.

When ignition occurs, the IGC board will continue to monitor the condition of the rollout switch, the limit switches, the "hall effect" sensor, as well as the flame sensor. 45 seconds after ignition occurs, assuming the unit is controlled through a room thermostat set for fan auto, the indoor-fan motor will energize (and the outdoor-air dampers will open to their minimum position). If, for some reason, the over-temperature limit opens prior to the start of the indoor fan blower, the unit will shorten the 45-second delay to 5 seconds less than the time from initiation of heat to when the limit tripped. Gas will not be interrupted to the burners and heating will continue. Once the fan-on delay has been modified, it will not change back to 45 seconds until power is reset to the control.

On units with 2 stages of heat, when additional heat is required, W2 closes and initiates power to the second stage of the main gas valve. When the thermostat is satisfied, W1 and W2 open and the gas valve closes, interrupting the flow of gas to the main burners.

If the call for W1 lasted less than 1 minute, the heating cycle will not terminate until 1 minute after W1 became active. If the unit is controlled through a room thermostat set for fan auto, the indoor-fan motor will continue to operate for an additional 45 seconds then stop. If the over-temperature limit opens after the indoor motor is stopped, but within 10 minutes of W1 becoming inactive, on the next cycle the time will be extended by 15 seconds. The maximum delay is 3 minutes. Once modified, the fan off delay will not change back to 45 seconds unless power is reset to the control. A LED indicator is provided on the IGC to monitor operation.

Units with an Economizer

Cooling —

When free cooling is not available, the compressors will be controlled by the zone thermostat. When free cooling is available, the outdoor-air damper is modulated by the economizer control to provide a 50°F (10°C) to 55°F (13°C) mixed-air temperature into the zone. As the mixed air temperature fluctuates above 55°F (13°C) or below 50°F (10°C) dampers will be modulated (open or close) to bring the mixed-air temperature back within control. If mechanical cooling is utilized with free cooling, the outdoor-air damper will maintain its current position at the time the compressor is started. If the increase in cooling capacity causes the mixed-air temperature to drop below 45°F (7°C), then the outdoor-air damper position will be decreased to the minimum position. If the mixed-air temperature continues to fall, the outdoor-air damper will close. Control returns to normal once the mixed-air temperature rises above 48°F (9°C). The power exhaust fans will be energized and de-energized, if installed, as the outdoor-air damper opens and closes.

If field-installed accessory CO2 sensors are connected to the economizer control, a demand controlled ventilation strategy will begin to operate. As the CO2 level in the zone increases above the CO2 set point, the minimum position of the damper will be increased proportionally. As the CO2 level decreases because of the increase in fresh air, the outdoor-air damper will be proportionally closed. For economizer operation, there must be a thermostat call for the fan (G). If the unit is occupied and the fan is on, the damper will operate at minimum position. Otherwise, the damper will be closed.

When the economizer control is in the occupied mode and a call for cooling exists (Y1 on the thermostat), the control will first check for indoor fan operation. If the fan is not on, then cooling will not be activated. If the fan is on, then the control will open the economizer damper to the minimum position.

On the initial power to the economizer control, it will take the damper up to 2 1/2 minutes before it begins to position itself. After the initial power-up, further changes in damper position can take up to 30 seconds to initiate. Damper movement from full closed to full open (or vice versa) will take between 1 1/2 and 2 1/2 minutes. If free cooling can be used as determined from the appropriate changeover command (switch, dry bulb, enthalpy curve, differential dry bulb, or differential enthalpy), then the control will modulate the dampers open to maintain the mixed-air temperature set point at 50°F (10°C) to 55°F (13°C). If there is a further demand for cooling (cooling second stage – Y2 is energized), then the control will bring on compressor stage 1 to maintain the mixed-air temperature set point. The economizer damper will be open at maximum position. economizer operation is limited to a single compressor.

Heating

The sequence of operation for the heating is the same as an unit with no economizer. The only difference is how the economizer acts. The economizer will stay at the Economizer Minimum Position while the evaporator fan is operating. The outdoor-air damper is closed when the indoor fan is not operating.

Appendix A – Altitude Compensation Tables

NATURAL GAS – SMALL CHASSIS / LOW NOx							
ELEVATION		NOMINAL HEAT INPUT					
		60k BTUH		90k BTUH		120k BTUH	
Feet	Meters	Orifice Size	Input (btu/hr)	Orifice Size	Input (btu/hr)	Orifice Size	Input (btu/hr)
0 – 2000	0 – 610	38 ²	60,000	38 ²	90,000	32 ¹	120,000
2000	610	39 ²	55,200	39 ²	82,800	33 ¹	110,400
3000	914	†40	52,800	†40	79,200	33 ¹	105,600
4000	1219	†41	50,400	†41	75,600	35 ¹	100,800
5000	1524	†41	48,000	†41	72,000	35 ¹	96,000
6000	1829	†42	45,600	†42	68,400	36 ¹	91,200
7000	2134	†42	43,200	†42	64,800	36 ¹	86,400
8000	2438	†43	40,800	†43	61,200	37 ²	81,600
9000	2743	†43	38,400	†43	57,600	38 ²	76,800
10000	3048	44 ²	36,000	44 ²	54,000	†40	72,000
11000	3353	44 ²	33,600	44 ²	50,400	†41	67,200
12000	3658	45 ²	31,200	45 ²	46,800	†42	62,400
13000	3962	47 ³	28,800	47 ³	43,200	†43	57,600
14000	4267	48 ³	26,400	48 ³	39,600	†43	52,800

NATURAL GAS – SMALL CHASSIS							
ELEVATION		NOMINAL HEAT INPUT					
		72k BTUH		115k BTUH		150k BTUH	
Feet	Meters	Orifice Size	Input (btu/hr)	Orifice Size	Input (btu/hr)	Orifice Size	Input (btu/hr)
0 – 2000	0 – 610	33 ¹	72,000	33 ¹	115,000	†30	150,000
2000	610	35 ¹	66,240	35 ¹	105,800	†30	138,000
3000	914	35 ¹	63,360	35 ¹	101,200	31 ¹	132,000
4000	1219	36 ¹	60,480	36 ¹	96,600	31 ¹	126,000
5000	1524	36 ¹	57,600	36 ¹	92,000	31 ¹	120,000
6000	1829	37 ²	54,720	37 ²	87,400	31 ¹	114,000
7000	2134	38 ²	51,840	38 ²	82,800	32 ¹	108,000
8000	2438	39 ²	48,960	39 ²	78,200	33 ¹	102,000
9000	2743	†40	46,080	†40	73,600	33 ¹	96,000
10000	3048	†41	43,200	†41	69,000	35 ¹	90,000
11000	3353	†42	40,320	†42	64,400	36 ¹	84,000
12000	3658	†43	37,440	†43	59,800	37 ²	78,000
13000	3962	†43	34,560	†43	55,200	38 ²	72,000
14000	4267	44 ²	31,680	44 ²	50,600	†40	66,000

PROPANE GAS – SMALL CHASSIS							
ELEVATION		NOMINAL HEAT INPUT					
		72k BTUH		115k BTUH		150k BTUH	
Feet	Meters	Orifice Size	Input (btu/hr)	Orifice Size	Input (btu/hr)	Orifice Size	Input (btu/hr)
0 – 2000	0 – 610	51 ⁴	72,000	50 ³	115,000	46 ³	150,000
2000	610	51 ⁴	66,240	51 ⁴	105,800	47 ³	138,000
3000	914	52 ⁴	63,360	51 ⁴	101,200	47 ³	132,000
4000	1219	52 ⁴	60,480	51 ⁴	96,600	48 ³	126,000
5000	1524	52 ⁴	57,600	51 ⁴	92,000	48 ³	120,000
6000	1829	52 ⁴	54,720	52 ⁴	87,400	48 ³	114,000
7000	2134	53 ⁴	51,840	52 ⁴	82,800	49 ³	108,000
8000	2438	53 ⁴	48,960	52 ⁴	78,200	49 ³	102,000
9000	2743	53 ⁴	46,080	53 ⁴	73,600	50 ³	96,000
10000	3048	54 ⁴	43,200	53 ⁴	69,000	50 ³	90,000
11000	3353	54 ⁴	40,320	53 ⁴	64,400	51 ⁴	84,000
12000	3658	54 ⁴	37,440	54 ⁴	59,800	51 ⁴	78,000
13000	3962	55 ⁴	34,560	54 ⁴	55,200	52 ⁴	72,000
14000	4267	†56	31,680	55 ⁴	50,600	53 ⁴	66,000

* As the height above sea level increases, there is less oxygen per cubic ft. of air. Therefore, heat input rate should be reduced at higher altitudes.

† Not included in kit. May be purchased separately through dealer.

ORIFICE	ACC. KIT PN
XX ¹	CRLPELEV001A00
XX ²	CRLPELEV002A00
XX ³	CRLPELEV003A00
XX ⁴	CRLPELEV004A00

Appendix A – Altitude Compensation Tables (Cont.)

NATURAL GAS – LARGE CHASSIS

ELEVATION		NOMINAL HEAT INPUT											
		72k BTUH		125k BTUH		150k BTUH		180k BTUH		224k BTUH		250k BTUH	
FT	M	Orifice Size	Input (btu/hr)	Orifice Size	Input (btu/hr)	Orifice Size	Input (btu/hr)	Orifice Size	Input (btu/hr)	Orifice Size	Input (btu/hr)	Orifice Size	Input (btu/hr)
0 – 2000	0 – 610	33 ¹	72,000	31 ¹	125,000	32 ¹	150,000	31 ¹	180,000	31 ¹	224,000	†30	250,000
2000	610	35 ¹	66,240	32 ¹	115,000	33 ¹	138,000	32 ¹	165,600	32 ¹	206,080	†30	230,000
3000	914	35 ¹	63,360	32 ¹	110,000	35 ¹	132,000	32 ¹	158,400	32 ¹	197,120	31 ¹	220,000
4000	1219	36 ¹	60,480	33 ¹	105,000	35 ¹	126,000	33 ¹	151,200	33 ¹	188,160	31 ¹	210,000
5000	1524	36 ¹	57,600	33 ¹	100,000	35 ¹	120,000	33 ¹	144,000	33 ¹	179,200	31 ¹	200,000
6000	1829	37 ²	54,720	35 ¹	95,000	36 ¹	114,000	33 ¹	136,800	33 ¹	170,240	31 ¹	190,000
7000	2134	38 ²	51,840	35 ¹	90,000	36 ¹	108,000	35 ¹	129,600	35 ¹	161,280	32 ¹	180,000
8000	2438	38 ²	48,960	36 ¹	85,000	36 ¹	102,000	36 ¹	122,400	36 ¹	152,320	33 ¹	170,000
9000	2743	†40	46,080	37 ²	80,000	37 ²	96,000	37 ²	115,200	37 ²	143,360	33 ¹	160,000
10000	3048	†41	43,200	38 ²	75,000	38 ²	90,000	38 ²	108,000	38 ²	134,400	35 ¹	150,000
11000	3353	†42	40,320	39 ²	70,000	†40	84,000	39 ²	100,800	39 ²	125,440	36 ¹	140,000
12000	3658	†42	37,440	†41	65,000	†40	78,000	†41	93,600	†41	116,480	37 ²	130,000
13000	3962	†43	34,560	†42	60,000	†41	72,000	†42	86,400	†42	107,520	38 ²	120,000
14000	4267	†43	31,680	†43	55,000	†41	66,000	†43	79,200	†43	98,560	†40	110,000

PROPANE GAS – LARGE CHASSIS

ELEVATION		NOMINAL HEAT INPUT											
		72k BTUH		125k BTUH		150k BTUH		180k BTUH		224k BTUH		250k BTUH	
FT	M	Orifice Size	Input (btu/hr)	Orifice Size	Input (btu/hr)	Orifice Size	Input (btu/hr)	Orifice Size	Input (btu/hr)	Orifice Size	Input (btu/hr)	Orifice Size	Input (btu/hr)
0 – 2000	0 – 610	51 ⁴	72,000	49 ³	125,000	50 ³	150,000	48 ³	180,000	48 ³	224,000	46 ³	250,000
2000	610	51 ⁴	66,240	50 ³	115,000	51 ⁴	138,000	49 ³	165,600	49 ³	206,080	47 ³	230,000
3000	914	52 ⁴	63,360	50 ³	110,000	51 ⁴	132,000	49 ³	158,400	49 ³	197,120	47 ³	220,000
4000	1219	52 ⁴	60,480	50 ³	105,000	51 ⁴	126,000	49 ³	151,200	49 ³	188,160	48 ³	210,000
5000	1524	52 ⁴	57,600	51 ⁴	100,000	51 ⁴	120,000	50 ³	144,000	50 ³	179,200	48 ³	200,000
6000	1829	52 ⁴	54,720	51 ⁴	95,000	52 ⁴	114,000	50 ³	136,800	50 ³	170,240	48 ³	190,000
7000	2134	53 ⁴	51,840	51 ⁴	90,000	52 ⁴	108,000	50 ³	129,600	50 ³	161,280	49 ³	180,000
8000	2438	53 ⁴	48,960	52 ⁴	85,000	52 ⁴	102,000	51 ⁴	122,400	51 ⁴	152,320	49 ³	170,000
9000	2743	53 ⁴	46,080	52 ⁴	80,000	53 ⁴	96,000	51 ⁴	115,200	51 ⁴	143,360	50 ³	160,000
10000	3048	54 ⁴	43,200	52 ⁴	75,000	53 ⁴	90,000	52 ⁴	108,000	52 ⁴	134,400	50 ³	150,000
11000	3353	54 ⁴	40,320	53 ⁴	70,000	53 ⁴	84,000	52 ⁴	100,800	52 ⁴	125,440	51 ⁴	140,000
12000	3658	54 ⁴	37,440	53 ⁴	65,000	53 ⁴	78,000	53 ⁴	93,600	53 ⁴	116,480	51 ⁴	130,000
13000	3962	55 ⁴	34,560	54 ⁴	60,000	53 ⁴	72,000	53 ⁴	86,400	53 ⁴	107,520	52 ⁴	120,000
14000	4267	55 ⁴	31,680	54 ⁴	55,000	55 ⁴	66,000	54 ⁴	79,200	54 ⁴	98,560	53 ⁴	110,000

* As the height above sea level increases, there is less oxygen per cubic ft. of air. Therefore, heat input rate should be reduced at higher altitudes.

† Not included in kit. May be purchased separately through dealer.

ORIFICE

XX¹
XX²
XX³
XX⁴

ACC. KIT PN

CRLPELEV001A00
CRLPELEV002A00
CRLPELEV003A00
CRLPELEV004A00

GUIDE SPECIFICATIONS – RGS036–180

Note about this specification:

GAS HEAT PACKAGED ROOFTOP

HVAC Guide Specifications

Size Range: 3 to 15 Nominal Tons



Section Description

23 06 80 Schedules for Decentralized HVAC Equipment

23 06 80.13 Decentralized Unitary HVAC Equipment Schedule

23 06 80.13.A. Rooftop unit schedule

1. Schedule is per the project specification requirements.

23 07 16 HVAC Equipment Insulation

23 07 16.13 Decentralized, Rooftop Units:

23 07 16.13.A. Evaporator fan compartment:

1. Interior cabinet surfaces shall be insulated with a minimum 1/2-in. thick, minimum 1 1/2 lb density, flexible fiberglass insulation bonded with a phenolic binder, neoprene coated on the air side.
2. Insulation and adhesive shall meet NFPA 90A requirements for flame spread and smoke generation.

23 07 16.13.B. Gas heat compartment:

1. Aluminum foil-faced fiberglass insulation shall be used.
2. Insulation and adhesive shall meet NFPA 90A requirements for flame spread and smoke generation.

23 09 13 Instrumentation and Control Devices for HVAC

23 09 13.23 Sensors and Transmitters

23 09 13.23.A, Thermostats

1. Thermostat must
 - a. energize both “W” and “G” when calling for heat.
 - b. have capability to energize 2 different stages of cooling, and 2 different stages of heating.
 - c. must include capability for occupancy scheduling.

23 09 33 Electric and Electronic Control System for HVAC

23 09 33.13 Decentralized, Rooftop Units:

23 09 33.13.A. General:

1. Shall be complete with self-contained low-voltage control circuit protected by a resettable circuit breaker on the 24-v transformer side. Transformer shall have 75VA capability.
2. Shall utilize color-coded wiring.
3. Unit shall include self-contained low-voltage control circuit protected by a fuse on the 24-v transformer side with a resettable circuit breaker.
4. The heat exchanger shall be controlled by an integrated gas controller (IGC) microprocessor. See heat exchanger section of this specification.
5. Unit shall include a minimum of one 8-pin screw terminal connection board for connection of control wiring.

23 09 33.23.B, Safeties:

1. Compressor over-temperature, over current.
2. Low-pressure switch.
 - a. Low pressure switch shall use different color wire than the high pressure switch. The purpose is to assist the installer and service person to correctly wire and or troubleshoot the rooftop unit.
3. High-pressure switch.
 - a. High pressure switch shall use different color wire than the low pressure switch. The purpose is to assist the installer and service person to correctly wire and or troubleshoot the rooftop unit.
4. Automatic reset, motor thermal overload protector.

5. Heating section shall be provided with the following minimum protections:

- a. High-temperature limit switches.
- b. Induced draft motor speed sensor.
- c. Flame rollout switch.
- d. Flame proving controls.

23 09 93 Sequence of Operations for HVAC Controls

23 09 93.13 Decentralized, Rooftop Units:

23 09 93.13 INSERT SEQUENCE OF OPERATION

23 40 13 Panel Air Filters

23 40 13.13 Decentralized, Rooftop Units:

23 40 13.13.A. Standard filter section shall

1. Shall consist of factory-installed, low velocity, throwaway 2-in. thick fiberglass filters of commercially available sizes.
2. Unit shall use only one filter size. Multiple sizes are not acceptable.
3. Filter face velocity shall not exceed 365 fpm at nominal airflows.
4. Filters shall be accessible through an access panel with “no-tool” removal as described in the unit cabinet section of this specification (23 81 19.13.H).

23 81 19 Self-Contained Air Conditioners

23 81 19.13 Small-Capacity Self-Contained Air Conditioners (RGS036-180)

23 81 19.13.A. General

1. Outdoor, rooftop mounted, electrically controlled, heating and cooling unit utilizing a(n) hermetic scroll compressor(s) for cooling duty and gas combustion for heating duty.
2. Factory assembled, single-piece heating and cooling rooftop unit. Contained within the unit enclosure shall be all factory wiring, piping, controls, and special features required prior to field start-up.
3. Unit shall use environmentally safe, R-410A refrigerant.
4. Unit shall be installed in accordance with the manufacturer’s instructions.
5. Unit must be selected and installed in compliance with local, state, and federal codes.

23 81 19.13.B. Quality Assurance

1. Unit meets ASHRAE 90.1-2004 minimum efficiency requirements.
2. 3 phase units are Energy Star qualified.
3. Unit shall be rated in accordance with ARI Standards 210 and 360.
4. Unit shall be designed to conform to ASHRAE 15, 2001.
5. Unit shall be UL-tested and certified in accordance with ANSI Z21.47 Standards and UL-listed and certified under Canadian standards as a total package for safety requirements.
6. Insulation and adhesive shall meet NFPA 90A requirements for flame spread and smoke generation.
7. Unit casing shall be capable of withstanding 500-hour salt spray exposure per ASTM B117 (scribed specimen).
8. Unit casing shall be capable of withstanding Federal Test Method Standard No. 141 (Method 6061) 5000-hour salt spray.
9. Unit shall be designed in accordance with ISO 9001:2000, and shall be manufactured in a facility registered by ISO 9001:2000.
10. Roof curb shall be designed to conform to NRCA Standards.
11. Unit shall be subjected to a completely automated run test on the assembly line. The data for each unit will be stored at the factory, and must be available upon request.
12. Unit shall be designed in accordance with UL Standard 1995, including tested to withstand rain.
13. Unit shall be constructed to prevent intrusion of snow and tested to prevent snow intrusion into the control box up to 40 mph.
14. Unit shake tested to assurance level 1, ASTM D4169 to ensure shipping reliability.

23 81 19.13.C. Delivery, Storage, and Handling

1. Unit shall be stored and handled per manufacturer’s recommendations.
2. Lifted by crane requires either shipping top panel or spreader bars.
3. Unit shall only be stored or positioned in the upright position.

23 81 19.13.E. Project Conditions

1. As specified in the contract.

23 81 19.13.F. Operating Characteristics

1. Unit shall be capable of starting and running at 115°F (46°C) ambient outdoor temperature, meeting maximum load criteria of ARI Standard 210/240 or 360 at ± 10% voltage.
2. Compressor with standard controls shall be capable of operation down to 40°F (4°C), ambient outdoor temperatures. Accessory winter start kit is necessary if mechanically cooling at ambient temperatures below 40°F (4°C) to 20°F (-7°C). Below 20°F (-7°C) an accessory Motormaster low ambient control is required and the outdoor fan motor needs to be changed to a ball-bearing speed control motor design..
3. Unit shall discharge supply air vertically or horizontally as shown on contract drawings.
4. Unit shall be factory configured for vertical supply & return configurations.
5. Unit shall be field convertible from vertical to horizontal configuration
6. Unit shall be capable of mixed operation: vertical supply with horizontal return or horizontal supply with vertical return.

23 81 19.13.G. Electrical Requirements

1. Main power supply voltage, phase, and frequency must match those required by the manufacturer.

23 81 19.13.H. Unit Cabinet

1. Unit cabinet shall be constructed of G90 galvanized steel, and shall be bonderized and coated with a pre-painted baked enamel finish on all externally exposed surfaces.
2. Unit cabinet exterior paint shall be: film thickness, (dry) 0.003 inches (.076mm) minimum, gloss (per ASTM D523, 60°F (16°C): 60, Hardness: H-2H Pencil hardness.
3. Evaporator fan compartment interior cabinet insulation shall conform to ARI Standards 210 or 360 minimum exterior sweat criteria. Interior surfaces shall be insulated with a minimum 1/2-in. thick, 1 lb density, flexible fiberglass insulation, neoprene coated on the air side. Aluminum foil-faced fiberglass insulation shall be used in the gas heat compartment.
4. Base of unit shall have a minimum of four locations for thru-the-base gas and electrical connections (factory installed or field installed), standard.
5. Base Rail
 - a. Unit shall have base rails on a minimum of 2 sides.
 - b. Holes shall be provided in the base rails for rigging shackles to facilitate maneuvering and overhead rigging.
 - c. Holes shall be provided in the base rail for moving the rooftop by fork truck.
 - d. Base rail shall be a minimum of 16 gauge thickness.
6. Condensate pan and connections:
 - a. Shall be a sloped condensate drain pan made of a non-corrosive material.
 - b. Shall comply with ASHRAE Standard 62.
 - c. Shall use a 3/4" -14 NPT drain connection, possible either through the bottom or end of the drain pan. Connection shall be made per manufacturer's recommendations.
7. Top panel:
 - a. Shall be a single piece top panel.
8. Gas Connections:
 - a. All gas piping connecting to unit gas valve shall enter the unit cabinet at a single location on side of unit (horizontal plane).
 - b. Thru-the-base capability
 - i. Standard unit shall have a thru-the-base gas-line location using a raised, embossed portion of the unit basepan.
 - ii. Optional, factory-approved, water-tight connection method must be used for thru-the-base gas connections.
 - iii. No basepan penetration, other than those authorized by the manufacturer, is permitted.
9. Electrical Connections
 - a. All unit power wiring shall enter unit cabinet at a single, factory-prepared, knockout location.
 - b. Thru-the-base capability
 - i. Standard unit shall have a thru-the-base electrical location(s) using a raised, embossed portion of the unit basepan.
 - ii. Optional, factory-approved, water-tight connection method must be used for thru-the-base electrical connections.
 - iii. No basepan penetration, other than those authorized by the manufacturer, is permitted.
10. Component access panels (standard)

- a. Cabinet panels shall be easily removable for servicing.
- b. Unit shall have one factory installed, tool-less, removable, filter access panel.
- c. Panels covering control box, indoor fan, indoor fan motor, gas components (where applicable), and compressors shall have a molded composite handles.
- d. Handles shall be UV modified, composite. They shall be permanently attached, and recessed into the panel.
- e. Screws on the vertical portion of all removable access panel shall engage into heat resistant, molded composite collars.
- f. Collars shall be removable and easily replaceable using manufacturer recommended parts.

23 81 19.13.I. Gas Heat

1. General

- a. Heat exchanger shall be an induced draft design. Positive pressure heat exchanger designs shall not be allowed.
- b. Shall incorporate a direct-spark ignition system and redundant main gas valve.
- c. Heat exchanger design shall allow combustion process condensate to gravity drain; maintenance to drain the gas heat exchanger shall not be required.
- d. Gas supply pressure at the inlet to the rooftop unit gas valve must match that required by the manufacturer.

2. The heat exchanger shall be controlled by an integrated gas controller (IGC) microprocessor.

- a. IGC board shall notify users of fault using an LED (light-emitting diode).
- b. The Light Emitting Diode (LED) shall be visible without removing the control box access panel.
- c. IGC board shall contain algorithms that modify evaporator-fan operation to prevent future cycling on high temperature limit switch.
- d. Unit shall be equipped with anti-cycle protection with one short cycle on unit flame rollout switch or 4 continuous short cycles on the high temperature limit switch. Fault indication shall be made using an LED.

3. Standard Heat Exchanger construction

- a. Heat exchanger shall be of the tubular-section type constructed of a minimum of 20-gauge steel coated with a nominal 1.2 mil aluminum-silicone alloy for corrosion resistance.
- b. Burners shall be of the in-shot type constructed of aluminum-coated steel.
- c. Burners shall incorporate orifices for rated heat output up to 2000 ft (610m) elevation. Additional accessory kits may be required for applications above 2000 ft (610m) elevation, depending on local gas supply conditions.
- d. Each heat exchanger tube shall contain multiple dimples for increased heating effectiveness.

4. Optional Stainless Steel Heat Exchanger construction

- a. Use energy saving, direct-spark ignition system
- b. Use a redundant main gas valve.
- c. Burners shall be of the in-shot type constructed of aluminum-coated steel.
- d. All gas piping shall enter the unit cabinet at a single location on side of unit (horizontal plane).
- e. The optional stainless steel heat exchanger shall be of the tubular-section type, constructed of a minimum of 20-gauge type 409 stainless steel.
- f. Type 409 stainless steel shall be used in heat exchanger tubes and vestibule plate.
- g. Complete stainless steel heat exchanger allows for greater application flexibility.

5. Optional Low NOx Heat Exchanger construction

- a. Low NOx reduction shall be provided to reduce nitrous oxide emissions to meet the California Air Quality Management NOx requirement of 40 nanograms/joule or less.
- b. Primary tubes and vestibule plates on low NOx units shall be 409 stainless steel. Other components shall be aluminized steel.

6. Induced draft combustion motor and blower

- a. Shall be a direct-drive, single inlet, forward-curved centrifugal type.
- b. Shall be made from steel with a corrosion-resistant finish.
- c. Shall have permanently lubricated sealed bearings.
- d. Shall have inherent thermal overload protection.
- e. Shall have an automatic reset feature.

23 81 19.13.J. Coils

1. Standard Aluminum/Copper Coils:

- a. Standard evaporator and condenser coils shall have aluminum lanced plate fins mechanically bonded to seamless internally grooved copper tubes with all joints brazed.
 - b. Evaporator and condenser coils shall be leak tested to 150 psig, pressure tested to 400 psig, and qualified to UL 1995 burst test at 2,200 psi.
2. Optional Pre-coated aluminum-fin coils:
 - a. Shall have a durable epoxy-phenolic coating to provide protection in mildly corrosive coastal environments.
 - b. Coating shall be applied to the aluminum fin stock prior to the fin stamping process to create an inert barrier between the aluminum fin and copper tube.
 - c. Epoxy-phenolic barrier shall minimize galvanic action between dissimilar metals.
 3. Optional Copper-fin coils:
 - a. Shall be constructed of copper fins mechanically bonded to copper tubes and copper tube sheets.
 - b. Galvanized steel tube sheets shall not be acceptable.
 - c. A polymer strip shall prevent coil assembly from contacting the sheet metal coil pan to minimize potential for galvanic corrosion between coil and pan.
 4. Optional E-coated aluminum-fin coils shall have a flexible epoxy polymer coating uniformly applied to all coil surface areas without material bridging between fins.
 - a. Coating process shall ensure complete coil encapsulation of tubes, fins and headers.
 - b. Color shall be high gloss black with gloss per ASTM D523-89.
 - c. Uniform dry film thickness from 0.8 to 1.2 mil on all surface areas including fin edges
 - d. Superior hardness characteristics of 2H per ASTM D3363-92A and cross-hatch adhesion of 4B-5B per ASTM D3359-93.
 - e. Impact resistance shall be up to 160 in.-lb (ASTM D2794-93).
 - f. Humidity and water immersion resistance shall be up to minimum 1000 and 250 hours respectively (ASTM D2247-92 and ASTM D870-92).
 - g. Corrosion durability shall be confirmed through testing to be no less than 1000 hours salt spray per ASTM B117-90.
 5. Optional E-coated copper-fin coils
 - a. Shall have a flexible epoxy polymer coating uniformly applied to all coil surface areas without material bridging between fins.
 - b. Galvanized steel tube sheets shall not be acceptable.
 - c. A polymer strip shall prevent coil assembly from contacting sheet metal coil pan to maintain coating integrity and minimize corrosion potential between coil and pan.
 - d. Coating process shall ensure complete coil encapsulation of tubes, fins and headers.
 - e. Color shall be high gloss black with gloss per ASTM D523-89.
 - f. Uniform dry film thickness from 0.8 to 1.2 mil on all surface areas including fin edges
 - g. Superior hardness characteristics of 2H per ASTM D3363-92A and cross-hatch adhesion of 4B-5B per ASTM D3359-93.
 - h. Impact resistance shall be up to 160 in.-lb (ASTM D2794-93).
 - i. Humidity and water immersion resistance shall be up to minimum 1000 and 250 hours respectively (ASTM D2247-92 and ASTM D870-92).
 - j. Corrosion durability shall be confirmed through testing to be no less than 1000 hours salt spray per ASTM B117-90.

23 81 19.13.K. Refrigerant Components

1. Refrigerant circuit shall include the following control, safety, and maintenance features:
 - a. Fixed orifice metering system shall prevent mal-distribution of two-phase refrigerant by including multiple fixed orifice devices in each refrigeration circuit. Each orifice is to be optimized to the coil circuit it serves.
 - b. Refrigerant filter drier.
 - c. Service gauge connections on suction and discharge lines.
 - d. Pressure gauge access through a specially designed access port in the top panel of the unit.
2. There shall be gauge line access port in the skin of the rooftop, covered by a black, removable plug (3 to 6 ton models only).
 - a. The plug shall be easy to remove and replace.
 - b. When the plug is removed, the gauge access port shall enable maintenance personnel to route their pressure gauge lines.

- c. This gauge access port shall facilitate correct and accurate condenser pressure readings by enabling the reading with the compressor access panel on.
- d. The plug shall be made of a leak proof, UV-resistant, composite material.

3. Compressors

- a. Unit shall use one fully hermetic, scroll compressor for each independent refrigeration circuit.
- b. Compressor motors shall be cooled by refrigerant gas passing through motor windings.
- c. Compressors shall be internally protected from high discharge temperature conditions using a Thermal Overload Disk (TOD) installed at the muffler plate on 036–060 sizes; a TOD installed at the fixed scroll discharge has outlet on 072–091 sizes; and Advanced Scroll Temperature Protection on 101–121 sizes.
- d. Compressors shall be protected from an over-temperature and over-ampereage conditions by an internal, motor overload device.
- e. Compressor shall be factory mounted on rubber grommets.
- f. Compressor motors shall have internal line break thermal and current overload protection.
- g. Crankcase heaters shall not be required for normal operating range.

23 81 19.13.L. Filter Section

1. Filters access is specified in the unit cabinet section of this specification.
2. Filters shall be held in place by a pivoting filter tray, facilitating easy removal and installation.
3. Shall consist of factory-installed, low velocity, throw-away 2-in. thick fiberglass filters.
4. Filter face velocity shall not exceed 320 fpm at nominal airflows.
5. Filters shall be standard, commercially available sizes.
6. Only one size filter per unit is allowed.

23 81 19.13.M. Evaporator Fan and Motor

1. Evaporator fan motor:
 - a. Shall have permanently lubricated bearings
 - b. Shall have inherent automatic-reset thermal overload protection.
 - c. Shall have a maximum continuous bhp rating for continuous duty operation; no safety factors above that rating shall be required.
2. Belt-driven Evaporator Fan:
 - a. Belt drive shall include an adjustable-pitch motor pulley.
 - b. Shall use sealed, permanently lubricated ball-bearing type.
 - c. Blower fan shall be double-inlet type with forward-curved blades.
 - d. Shall be constructed from steel with a corrosion resistant finish and dynamically balanced.

23 81 19.13.N. Condenser Fans and Motors

1. Condenser fan motors:
 - a. Shall be a totally enclosed motor.
 - b. Shall use permanently lubricated bearings.
 - c. Shall have inherent thermal overload protection with an automatic reset feature.
 - d. Shall use a shaft-down design. Shaft-up designs including those with “rain-slinger devices” shall not be allowed.
2. Condenser Fans shall:
 - a. Shall be a direct-driven propeller type fan
 - b. Shall have aluminum blades riveted to corrosion-resistant steel spiders and shall be dynamically balanced.

23 81 19.13.O. Special Features

1. Integrated Economizers:
 - a. Integrated, gear-driven parallel modulating blade design type capable of simultaneous economizer and compressor operation.
 - b. Independent modules for vertical or horizontal return configurations shall be available. Vertical return modules shall be available as a factory installed option.
 - c. Damper blades shall be galvanized steel with composite gears. Plastic or composite blades on intake or return shall not be acceptable.
 - d. Shall include all hardware and controls to provide free cooling with outdoor air when temperature and/or humidity are below setpoints.
 - e. Shall be equipped with gear driven dampers for both the outdoor ventilation air and the return air for positive air stream control.
 - f. Shall be equipped with low-leakage dampers, not to exceed 2% leakage at 1 in. wg pressure differential.

- g. Shall be capable of introducing up to 100% outdoor air.
 - h. Shall be equipped with a barometric relief damper capable of relieving up to 100% return air.
 - i. Shall be designed to close damper(s) during loss-of-power situations with spring return built into motor.
 - j. Dry bulb outdoor-air temperature sensor shall be provided as standard. Outdoor air sensor set point shall be adjustable and shall range from 40 to 100°F / 4 to 38°C. Additional sensor options shall be available as accessories.
 - k. The economizer controller shall also provide control of an accessory power exhaust unit. function. Factory set at 100%, with a range of 0% to 100%.
 - l. The economizer shall maintain minimum airflow into the building during occupied period and provide design ventilation rate for full occupancy. A remote potentiometer may be used to override the damper set point.
 - m. Dampers shall be completely closed when the unit is in the unoccupied mode.
 - n. Economizer controller shall accept a 2–10Vdc CO2 sensor input for IAQ/DCV control. In this mode, dampers shall modulate the outdoor-air damper to provide ventilation based on the sensor input.
 - o. Compressor lockout sensor shall open at 35°F (2°C) and close closes at 50°F (10°C).
 - p. Actuator shall be direct coupled to economizer gear. No linkage arms or control rods shall be acceptable.
 - q. Economizer controller shall provide indications when in free cooling mode, in the DCV mode, or the exhaust fan contact is closed.
 - r. Economizer uses a mixed air thermister (MAT) located on indoor fan housing to modulate outdoor air dampers and return air dampers to control to a 55°F (13°C) discharge air temperature
2. Two-Position Damper
- a. Damper shall be a Two-Position Damper. Damper travel shall be from the full closed position to the field adjustable %-open setpoint.
 - b. Damper shall include adjustable damper travel from 25% to 100% (full open).
 - c. Damper shall include single or dual blade, gear driven dampers and actuator motor.
 - d. Actuator shall be direct coupled to economizer gear. No linkage arms or control rods shall be acceptable.
 - e. Damper will admit up to 100% outdoor air for applicable rooftop units.
 - f. Damper shall close upon indoor (evaporator) fan shutoff and/or loss of power.
 - g. Design shall incorporate inherent barometric relief capabilities for barometric relief of rooftop unit return air.
 - h. The damper actuator shall plug into the rooftop unit's wiring harness plug. No hard wiring shall be required.
 - i. Outside air hood shall include aluminum water entrainment filter
3. Manual damper
- a. Manual damper field installed accessory package shall consist of damper, air inlet screen, and rain hood which can be preset to admit up to 50% outdoor air for year round ventilation.
4. Head Pressure Control Package
- a. Controller shall control coil head pressure by condenser-fan speed modulation or condenser-fan cycling and wind baffles.
 - b. Shall consist of solid-state control and condenser-coil temperature sensor to maintain condensing temperature between 90°F (32°C) and 110°F (43°C) at outdoor ambient temperatures down to -20°F (-29°C).
5. Liquid Propane (LP) Conversion Kit
- a. Package shall contain all the necessary hardware and instructions to convert a standard natural gas unit for use with liquefied propane, up to 2000 ft (610m) elevation.
 - b. Additional accessory kits may be required for applications above 2000 ft (610m) elevation.
6. Flue Shield
- a. Flue shield shall provide protection from the hot sides of the gas flue hood.
7. Condenser Coil Hail Guard Assembly
- a. Shall protect against damage from hail.
 - b. Shall be either hood style or louvered.
8. Unit-Mounted, Non-Fused Disconnect Switch:
- a. Switch shall be factory-installed, internally mounted.
 - b. National Electric Code (NEC) and UL approved non-fused switch shall provide unit power shutoff.
 - c. Shall be accessible from outside the unit
 - d. Shall provide local shutdown and lockout capability.
9. Convenience Outlet:
- a. Non-Powered convenience outlet.
 - b. Outlet shall be powered from a separate 115–120v power source.

- c. A transformer shall not be included.
 - d. Outlet shall be factory-installed and internally mounted with easily accessible 115-v female receptacle.
 - e. Outlet shall include 15 amp GFI receptacles with independent fuse protection.
 - f. Outlet shall be accessible from outside the unit.
10. Flue Discharge Deflector:
- a. Flue discharge deflector shall direct unit exhaust vertically instead of horizontally.
 - b. Deflector shall be defined as a “natural draft” device by the National Fuel and Gas (NFG) code.
11. Thru-the-Base Connectors:
- a. Kits shall provide connectors to permit gas and electrical connections to be brought to the unit through the unit basepan.
 - b. Maximum of four connection locations per unit.
12. Supply Duct Cover
- a. Required when field converting the factory standard vertical duct supply to horizontal duct supply configuration. One required per unit.
13. Propeller Power Exhaust:
- a. Power exhaust shall be used in conjunction with an integrated economizer.
 - b. Independent modules for vertical or horizontal return configurations shall be available.
 - c. Horizontal power exhaust is shall be mounted in return ductwork.
 - d. Power exhaust shall be controlled by economizer controller operation. Exhaust fans shall be energized when dampers open past the 0-100% adjustable setpoint on the economizer control.
14. Roof Curbs (Vertical):
- a. Full perimeter roof curb with exhaust capability providing separate airstreams for energy recovery from the exhaust air without supply air contamination.
 - b. Formed galvanized steel with wood nailer strip and shall be capable of supporting entire unit weight.
 - c. Permits installation and securing of ductwork to curb prior to mounting unit on the curb.
15. High-Altitude Gas Conversion Kit:
- a. Package shall contain all the necessary hardware and instructions to convert a standard natural gas unit to operate from 2000-7000 ft (610 to 2134m) elevation with natural gas or from 0-7000 ft 90-2134m) elevation with liquefied propane.
16. High-Static Indoor Fan Motor(s) and Drive(s):
- a. Medium and High-static motor(s) and drive(s) shall be factory-installed to provide additional performance range.
17. Condenser Coil Grille:
- a. The grille protects the condenser coil from damage by large objects without increasing unit clearances.
18. Outdoor Air Enthalpy Sensor:
- a. The outdoor air enthalpy sensor shall be used to provide single enthalpy control. When used in conjunction with a return air enthalpy sensor, the unit will provide differential enthalpy control. The sensor allows the unit to determine if outside air is suitable for free cooling.
19. Return Air Enthalpy Sensor:
- a. The return air enthalpy sensor shall be used in conjunction with an outdoor air enthalpy sensor to provide differential enthalpy control.
20. Indoor Air Quality (CO2) Sensor:
- a. Shall be able to provide demand ventilation indoor air quality (IAQ) control.
 - b. The IAQ sensor shall be available in duct mount. The set point shall have adjustment capability.
21. Smoke detector:
- a. Shall be a Four-Wire Controller and Detector.
 - b. Shall be environmental compensated with differential sensing for reliable, stable, and drift-free sensitivity.
 - c. Shall use magnet-activated test/reset sensor switches.
 - d. Shall have tool-less connection terminal access.
 - e. Shall have a recessed momentary switch for testing and resetting the detector.
 - f. Controller shall include:
 - i. One set of normally open alarm initiation contacts for connection to an initiating device circuit on a fire alarm control panel
 - ii. Two Form-C auxiliary alarm relays for interface with rooftop unit or other equipment

- iii. One Form-C supervision (trouble) relay to control the operation of the Trouble LED on a remote test/reset station
 - iv. Capable of direct connection to two individual detector modules
 - v. Can be wired to up to 14 other duct smoke detectors for multiple fan shutdown applications
22. Winter start kit
- a. Shall contain a bypass device around the low pressure switch.
 - b. Shall be required when mechanical cooling below an outdoor ambient of 40°F (4°C) to 25°F (-4°C).
 - c. Shall not be required to operate an equipped economizer when below an outdoor ambient of 40°F (4°C).
23. Barometric relief
- a. Shall include damper, seals, hard-ware, and hoods to relieve excess building pressure.
 - b. Damper shall gravity-close upon unit shutdown.
24. Time Guard
- a. Shall prevent compressor short cycling by providing a 5-minute delay (± 2 minutes) before restarting a compressor after shutdown for any reason.
 - b. One device shall be required per compressor.
25. Phase Monitor Control
- a. Field installed accessory that provides phase loss / phase reversal protection.
 - b. Mounts in unit control box and connects to unit main terminal board.