

13 SEER PACKAGE GAS / ELECTRIC UNIT (Single Phase) 2 to 5 TON

REFRIGERATION CIRCUIT

- All models are equipped with high efficiency Copeland scroll compressor, 4 & 5 ton have two-stage scroll compressors.
- Thermostat Expansion Valve (TXV) controls refrigerant flow.
- High Efficiency indoor motors on all models.
- Factory charged with R-22 refrigerant.

BUILT TO LAST

- Aluminized serpentine clamshell heat exchanger.
- Galvanized-painted cabinet. One piece weather resistant top. Access panels for easy service. Side by side supply and return. Heavy gauge base rails.
- Triple-coated steel, consisting of a Polyester top coat, a urethane primer coat preceded by an oxide pretreatment.
- Integral base rails with fork-lift access. Holes provided for lifting lugs makes rooftop installation easier.
- The condenser coil has a sturdy wire inlet grille and UV rated vinyl mesh installed on the surface of the coil for additional protection.
- Drawn fan orifice and swept fan blades on most models for quieter operation.



EASY TO INSTALL AND SERVICE

- Combination gas heating and electric cooling, self contained for year-round comfort. Systems installed on rooftop or ground level. The unit is shipped in the horizontal position and can easily be converted to downflow.
- Externally-mounted gauge ports allow for more accurate reading of operating conditions while servicing.
- Electrical and gas controls located behind one exterior panel for easier maintenance.
- Adjustable electronic fan control with optional low speed continuous fan feature responds quickly to circulate heated air and provide maximum comfort.

WARRANTY*

- 15 Year heat exchanger limited warranty
- 5 year parts limited warranty (including compressor and coil)

*Applies to original purchaser/homeowner, some limitations may apply. See warranty certificate for complete details.



UNIT PERFORMANCE DATA (1 Phase - 60 Hz)

Model Number	COOLING		HEATING		Voltage-Phas-Hz	Unit Dimensions H x W x L	Ship Weight
	Rated Capacity BTUH	S.E.E.R	Input (BTUH)	Efficiency (AFUE%)			
PGF324040K0*A	23,000	13.2	40,000	80.0	208/230-1-60	29-1/2 X 47-1/2 X 47-1/2	343
PGF324060K0*A	23,000	13.2	60,000	79.6	208/230-1-60	29-1/2 X 47-1/2 X 47-1/2	353
PGF330060K0*A	28,600	13.2	60,000	79.6	208/230-1-60	37-1/2 X 47-1/2 X 47-1/2	332
PGF330080K0*A	28,600	13.2	80,000	80.0	208/230-1-60	37-1/2 X 47-1/2 X 47-1/2	337
PGF336060K0*A	35,000	13.2	60,000	79.6	208/230-1-60	37-1/2 X 47-1/2 X 47-1/2	348
PGF336080K0*A	35,000	13.2	80,000	80.0	208/230-1-60	37-1/2 X 47-1/2 X 47-1/2	354
PGF336100K0*A	35,000	13.2	100,000	78.5	208/230-1-60	37-1/2 X 47-1/2 X 47-1/2	356
PGF342080K0*A	40,000	13.2	80,000	79.8	208/230-1-60	37-1/2 X 47-1/2 X 47-1/2	450
PGF342100K0*A	40,000	13.2	100,000	78.6	208/230-1-60	37-1/2 X 47-1/2 X 47-1/2	455
PGF348080K0*A	44,500	13.2	80,000	80.0	208/230-1-60	37-1/2 X 47-1/2 X 51	535
PGF348120K0*A	44,500	13.2	120,000	80.0	208/230-1-60	37-1/2 X 47-1/2 X 51	540
PGF354100K0*A	53,000	13.2	100,000	80.0	208/230-1-60	37-1/2 X 47-1/2 X 51	560
PGF354140K0*A	53,000	13.2	140,000	79.2	208/230-1-60	37-1/2 X 47-1/2 X 51	565

* 0 = Standard Model, 1 = Low Nox California Model

UNIT SPECIFICATIONS

MODEL * NUMBER	Electrical Data			Condenser Data									Sound Ratings (db)
				Coil			Fan Motor			Fan			
	208 / 230 Voltage Phase - Hz	Maximum Overcurrent Protection	Minimum Circuit Ampacity	Total Face Area (Sq. Ft.)	Fins Per In. / Rows	Tube Diameter (In.)	HP	Full Load Amps	Locked Rotor Amps	Size Diameter (In.)	RPM (Max.)	CFM (Design)	
PGF324040K0*A	1-60	25 amps.	18.0	11.19	18 / 2	3/8	1/8	0.9	1.6	20	825	2100	72
PGF324060K0*A	1-60	25 amps.	18.0				1/8	0.9	1.6	20	825	2100	72
PGF330060K0*A	1-60	30 amps.	22.6	13.5	18 / 2	3/8	1/8	0.9	1.6	20	825	2100	74
PGF330080K0*A	1-60	30 amps.	22.6				1/8	0.9	1.6	20	825	2100	74
PGF336060K0*A	1-60	40 amps.	25.4	14.6	18 / 2	3/8	1/4	1.4	3.7	20	1100	2700	76
PGF336080K0*A	1-60	40 amps.	25.4				1/4	1.4	3.7	20	1100	2700	76
PGF336100K0*A	1-60	40 amps.	25.4				1/4	1.4	3.7	20	1100	2700	76
PGF342080K0*A	1-60	40 amps.	28.1	14.6	18 / 2	3/8	1/4	1.4	3.7	20	1100	2700	78
PGF342100K0*A	1-60	40 amps.	28.1				1/4	1.4	3.7	20	1100	2700	78
PGF348080K0*A	1-60	50 amps.	35.9	13.5	18 / 2	3/8	1/4	1.4	3.7	20	1100	3000	78
PGF348120K0*A	1-60	50 amps.	35.9				1/4	1.4	3.7	20	1100	3000	78
PGF354100K0*A	1-60	60 amps.	38.3	14.6	18 / 2	3/8	1/2	3.0	6.7	20	1100	3400	80
PGF354140K0*A	1-60	60 amps.	38.3				1/2	3.0	6.7	20	1100	3400	80

* 0 = Standard Model, 1 = Low Nox California Model

MODEL * NUMBER	Evaporator Coil							Scroll Compressor				Ship Weight (Lbs./kg.)	
	Coil			Blower H.P.	Motor		Blower			Rated Load Amps	Locked Rotor Amps		Refrigerant Charge R-22 (lbs.)
	Total Face Area (Sq. Ft.)	Fins Per In. / Rows	Tube Diam. (In.)		Full Load Amps	NO. of Speed Taps	Size	RPM (Max)	CFM Rated				
PGF324040K0*A	4.0	14 / 3	3/8	1/2	4.1	4	10 x 8	1050	800	10.4	54.0	4.0	343 / 156
PGF324060K0*A	4.0	14 / 3	3/8	1/2	4.1	4	10 x 8	1050	800	10.4	54.0	4.0	353 / 160
PGF330060K0*A	5.33	14 / 3	3/8	1/2	4.1	4	10 x 8	1050	1000	14.1	72.5	5.9	332 / 151
PGF330080K0*A	5.33	14 / 3	3/8	1/2	4.1	4	10 x 8	1050	1000	14.1	72.5	5.9	337 / 153
PGF336060K0*A	5.33	14 / 3	3/8	3/4	6.0	4	11 x 9	1050	1200	14.4	88.0	9.2	349 / 158
PGF336080K0*A	5.33	14 / 3	3/8	3/4	6.0	4	11 x 9	1050	1200	14.4	88.0	9.2	354 / 160
PGF336100K0*A	5.33	14 / 3	3/8	3/4	6.0	4	11 x 9	1050	1200	14.4	88.0	9.2	356 / 161
PGF342080K0*A	5.33	14 / 4	3/8	3/4	6.0	4	11 x 9	1050	1400	16.5	95.0	11.8	425 / 193
PGF342100K0*A	5.33	14 / 4	3/8	3/4	6.0	4	11 x 9	1050	1400	16.5	95.0	11.8	425 / 193
PGF348080K0*A	5.33	14 / 4	3/8	1.0	7.7	4	11 x 10	1050	1600	21.5	116.0	13.0	498 / 226
PGF348120K0*A	5.33	14 / 4	3/8	1.0	7.7	4	11 x 10	1050	1600	21.5	116.0	13.0	498 / 226
PGF354100K0*A	5.33	14 / 4	3/8	1.0	7.7	4	11 x 10	1050	2000	22.1	118.0	13.3	509 / 231
PGF354140K0*A	5.33	14 / 4	3/8	1.0	7.7	4	11 x 10	1050	2000	22.1	118.0	13.3	509 / 231

* 0 = Standard Model, 1 = Low Nox California Model

UNIT PERFORMANCE DATA (1 Phase - 60 Hz)

Model Number	COOLING				HEATING		Voltage-Phase-Hz	Unit Dimensions H x W x L
	Rated Capacity BTUH	S.E.E.R	E.E.R.	S/T Ratio	Input (BTUH)	Efficiency (AFUE%)		
PGF324040K0*A	23,000	13.2	11.3	0.76	40,000	80.0	208/230-1-60	29-1/2 X 47-1/2 X 47-1/2
PGF324060K0*A	23,000	13.2	11.3	0.76	60,000	79.6	208/230-1-60	29-1/2 X 47-1/2 X 47-1/2
PGF330060K0*A	28,600	13.2	11.1	0.76	60,000	79.6	208/230-1-60	37-1/2 X 47-1/2 X 47-1/2
PGF330080K0*A	28,600	13.2	11.1	0.76	80,000	80.0	208/230-1-60	37-1/2 X 47-1/2 X 47-1/2
PGF336060K0*A	35,000	13.2	11.3	0.76	60,000	79.6	208/230-1-60	37-1/2 X 47-1/2 X 47-1/2
PGF336080K0*A	35,000	13.2	11.3	0.76	80,000	80.0	208/230-1-60	37-1/2 X 47-1/2 X 47-1/2
PGF336100K0*A	35,000	13.2	11.3	0.76	100,000	78.6	208/230-1-60	37-1/2 X 47-1/2 X 47-1/2
PGF342080K0*A	40,000	13.2	11.0	0.76	80,000	79.8	208/230-1-60	37-1/2 X 47-1/2 X 47-1/2
PGF342100K0*A	40,000	13.2	11.0	0.76	100,000	78.6	208/230-1-60	37-1/2 X 47-1/2 X 47-1/2
PGF348080K0*A	44,500	13.2	10.2	0.76	80,000	80.0	208/230-1-60	37-1/2 X 47-1/2 X 51
PGF348120K0*A	44,500	13.2	10.2	0.76	120,000	80.0	208/230-1-60	37-1/2 X 47-1/2 X 51
PGF354100K0*A	53,000	13.2	9.8	0.75	100,000	80.0	208/230-1-60	37-1/2 X 47-1/2 X 51
PGF354140K0*A	53,000	13.2	9.8	0.75	140,000	79.2	208/230-1-60	37-1/2 X 47-1/2 X 51

* 0 = Standard Model, 1 = Low Nox California Model

PGF3 SERIES HEATING CHART

					External Static Pressure (in H ₂ O)															
					.1"		.2"		.3"		.4"		.5"		.6"		.7"		.8"	
Model	Cooling Tons	Heating Input (Btu/hr)	Heating Rise Range (°F)	Speed Tap	CFM	Heating Rise (°F)	CFM	Heating Rise (°F)	CFM	Heating Rise (°F)	CFM	Heating Rise (°F)	CFM	Heating Rise (°F)	CFM	Heating Rise (°F)	CFM	Heating Rise (°F)	CFM	Heating Rise (°F)
PGF324040K****	2	40000	30 - 60	4	1211	NA	1175	NA	1134	NA	1086	NA	1044	NA	985	30	841	35	604	49
				3	1136	NA	1098	NA	1056	NA	1020	NA	980	30	920	32	785	38	569	52
				2	968	31	927	32	885	33	859	34	790	37	735	40	657	45	524	57
				1	891	33	845	35	804	37	758	39	707	42	649	46	582	51	509	58
PGF324060K****	2	60000	30 - 60	4	1211	37	1175	38	1134	39	1086	41	1044	43	985	45	841	53	604	NA
				3	1136	39	1098	40	1056	42	1020	44	980	45	920	48	785	57	569	NA
				2	968	46	927	48	885	50	859	52	790	56	735	NA	657	NA	524	NA
				1	891	50	845	53	804	55	758	59	707	NA	649	NA	582	NA	509	NA
PGF330060K****	2.5	60000	30 - 60	4	1352	33	1311	34	1274	35	1233	36	1203	37	1162	38	1119	40	1066	41
				3	1268	35	1225	36	1186	37	1158	38	1129	39	1085	41	1044	42	1004	44
				2	1076	41	1038	43	997	44	973	45	913	48	875	51	840	53	786	56
				1	986	45	949	47	908	49	856	52	819	54	781	57	717	NA	664	NA
PGF330080K****	2.5	80000	35 - 65	4	1352	44	1311	45	1274	46	1233	48	1203	49	1162	51	1119	53	1066	55
				3	1268	47	1225	48	1186	50	1158	51	1129	52	1085	54	1044	57	1004	59
				2	1076	55	1038	57	997	59	973	61	913	65	875	NA	840	NA	786	NA
				1	986	60	949	62	908	65	856	NA	819	NA	781	NA	717	NA	664	NA
PGF336060K****	3	60000	30 - 60	4	1652	NA	1607	NA	1574	NA	1541	NA	1500	NA	1462	30	1426	31	1384	32
				3	1529	NA	1484	30	1440	31	1402	32	1364	32	1326	33	1284	34	1238	36
				2	1278	35	1233	36	1191	37	1149	38	1108	40	1060	42	1005	44	943	47
				1	1162	38	1118	40	1062	42	1014	44	958	46	892	50	826	54	780	57
PGF336080K****	3	80000	35 - 65	4	1652	36	1607	37	1574	38	1541	38	1500	39	1462	40	1426	41	1384	43
				3	1529	39	1484	40	1440	41	1402	42	1364	43	1326	45	1284	46	1238	48
				2	1278	46	1233	48	1191	50	1149	51	1108	53	1060	56	1005	59	943	63
				1	1162	51	1118	53	1062	56	1014	58	958	62	892	NA	826	NA	780	NA
PGF336100K****	3	100000	35 - 65	4	1652	44	1607	45	1574	46	1541	47	1500	48	1462	50	1426	51	1384	53
				3	1529	48	1484	49	1440	50	1402	52	1364	53	1326	55	1284	57	1238	59
				2	1278	57	1233	59	1191	61	1149	63	1108	NA	1060	NA	1005	NA	943	NA
				1	1162	63	1118	65	1062	NA	1014	NA	958	NA	892	NA	826	NA	780	NA
PGF342080K****	3.5	80000	35 - 65	4	1643	36	1609	37	1577	37	1541	38	1509	39	1476	40	1439	41	1402	42
				3	1505	39	1467	40	1431	41	1398	42	1363	43	1324	45	1283	46	1234	48
				2	1240	48	1189	50	1145	52	1104	54	1063	56	1010	59	952	62	891	NA
				1	1138	52	1087	54	1041	57	989	60	940	63	865	NA	806	NA	752	NA
PGF342100K****	3.5	100000	35 - 65	4	1643	44	1609	45	1577	46	1541	47	1509	48	1476	49	1439	51	1402	52
				3	1505	48	1467	50	1431	51	1398	52	1363	53	1324	55	1283	57	1234	59
				2	1240	59	1189	61	1145	63	1104	NA	1063	NA	1010	NA	952	NA	891	NA
				1	1138	64	1087	NA	1041	NA	989	NA	940	NA	865	NA	806	NA	752	NA
PGF348080K****	4	80000	35 - 65	4	1908	NA	1864	NA	1819	NA	1770	NA	1720	NA	1678	35	1632	36	1586	37
				3	1750	34	1696	35	1643	36	1592	37	1547	38	1497	40	1443	41	1400	42
				2	1245	48	1170	51	1110	53	1034	57	972	61	924	64	875	NA	836	NA
				1	1154	51	1084	55	1005	59	940	63	880	NA	832	NA	780	NA	713	NA
PGF348120K****	4	120000	40 - 70	4	1908	47	1864	48	1819	49	1770	50	1720	52	1678	53	1632	54	1586	56
				3	1750	51	1696	52	1643	54	1592	56	1547	57	1497	59	1443	62	1400	63
				2	1245	NA	1170	NA	1110	NA	1034	NA	972	NA	924	NA	875	NA	836	NA
				1	1154	NA	1084	NA	1005	NA	940	NA	880	NA	832	NA	780	NA	713	NA
PGF354100K****	5	100000	30 - 60	4	2173	34	2113	35	2067	36	2032	36	2003	37	1962	38	1904	39	1822	41
				3	2109	35	2052	36	2000	37	1952	38	1899	39	1847	40	1798	41	1750	42
				2	1449	51	1372	54	1318	56	1258	59	1195	NA	1130	NA	1086	NA	1048	NA
				1	1348	55	1274	58	1218	NA	1151	NA	1085	NA	1032	NA	989	NA	954	NA
PGF354140K****	5	140000	35 - 65	4	2173	48	2113	49	2067	50	2032	51	2003	52	1962	53	1904	54	1822	57
				3	2109	49	2052	51	2000	52	1952	53	1899	55	1847	56	1798	58	1750	59
				2	1449	NA	1372	NA	1318	NA	1258	NA	1195	NA	1130	NA	1086	NA	1048	NA
				1	1348	NA	1274	NA	1218	NA	1151	NA	1085	NA	1032	NA	989	NA	954	NA

BLOWER PERFORMANCE DATA

Model Number	PGF324--K-A				PGF330--K-A				PGF336--K-A				PGF342--K-A				PGF348--K-A				PGF354--K-A				
	Speed Tap	1	2	3	4	1	2	3	4	1	2	3	4	1	2	3	4	1	2	3	4	1	2	3	4
Air Delivery in CFM @ Varying External Static Pressure (in. w.c.)	0.1	891	-	1136	-	986	1076	1286	1352	1162	1278	1529	1652	1138	1240	1505	1643	1154	1245	1750	1908	1348	1449	1998	2173
	0.2	845	-	1098	-	949	1038	1225	1311	1118	1233	1484	1607	1087	1189	1467	1609	1084	1170	1696	1864	1274	1372	1943	2113
	0.3	804	-	1056	-	908	997	1186	1274	1062	1191	1440	1574	1041	1145	1431	1577	1005	1110	1643	1819	1218	1318	1895	2067
	0.4	758	-	1020	-	856	973	1158	1233	1014	1149	1402	1541	989	1104	1398	1541	940	1034	1592	1770	1151	1258	1850	2032
	0.5	707	-	980	-	819	913	1129	1203	958	1108	1364	1501	940	1063	1363	1509	880	972	1547	1720	1085	1195	1800	2003
	0.6	649	-	920	-	781	875	1085	1162	892	1060	1326	1462	865	1010	1324	1476	832	924	1497	1678	1032	1130	1750	1962
	0.7	582	-	785	-	717	840	1044	1119	826	1005	1284	1426	806	952	1283	1439	780	875	1443	1632	989	1086	1705	1904
	0.8	509	-	569	-	664	786	1004	1066	780	943	1238	1384	752	891	1234	1402	713	836	1400	1586	954	1048	1659	1822
	0.9	-	-	318	-	612	717	948	989	735	892	1179	1338	694	828	1175	1352	663	773	1354	1538	904	1000	1602	1727
	1	-	-	-	-	554	659	755	774	675	844	1123	1277	646	773	1120	1264	613	720	1302	1494	851	946	1530	1603

EXPANDED PERFORMANCE DATA (COOLING) - 2 TON

		PGF324--K-A														
		700					800					900				
OD Ambient (°F)	ID Airflow (SCFM)	Entering Indoor Temperature - Degrees F, Wet Bulb														
		57	62	63†	67	72	57	62	63†	67	72	57	62	63†	67	72
75	MBh†	22.1	23.0	23.5	25.2	26.5	23.3	23.8	24.1	25.5	26.6	24.3	24.3	24.4	25.8	27.4
	S/T	1.00	0.91	0.73	0.70	0.52	1.00	0.96	0.76	0.73	0.53	1.00	0.99	0.80	0.77	0.53
	kW*	1.7	1.7	1.7	1.7	1.7	1.8	1.8	1.8	1.8	1.8	1.8	1.8	1.8	1.9	1.9
85	MBh†	21.3	22.0	22.5	24.5	26.3	22.5	22.7	23.1	25.1	26.4	23.5	23.5	23.7	25.5	27.1
	S/T	1.00	0.93	0.74	0.71	0.52	1.00	0.98	0.77	0.74	0.55	1.00	0.99	0.81	0.78	0.56
	kW*	1.9	1.9	1.9	1.9	1.9	2.0	2.0	2.0	2.0	2.0	2.0	2.0	2.0	2.0	2.1
95	MBh†	20.5	20.9	21.4	22.9	26.0	21.6	21.6	22.0	23.0	26.1	22.6	22.6	22.5	24.5	26.8
	S/T	1.01	0.96	0.75	0.72	0.52	1.00	0.99	0.79	0.76	0.55	1.00	1.00	0.83	0.80	0.56
	kW*	2.1	2.1	2.1	2.1	2.1	2.2	2.2	2.2	2.2	2.2	2.2	2.2	2.2	2.3	2.3
105	MBh†	19.6	19.8	20.2	22.1	24.9	20.7	20.7	20.8	22.7	25.5	21.6	21.6	21.2	23.2	26.0
	S/T	1.00	0.99	0.77	0.74	0.53	1.00	0.99	0.81	0.78	0.55	1.00	1.00	0.85	0.82	0.57
	kW*	2.3	2.3	2.3	2.3	2.4	2.4	2.4	2.4	2.4	2.4	2.5	2.5	2.5	2.5	2.5
115	MBh†	18.6	18.7	19.0	20.9	23.6	19.6	19.7	19.5	21.4	24.2	20.5	20.5	19.9	21.9	24.6
	S/T	1.00	1.00	0.79	0.76	0.54	1.00	0.99	0.84	0.80	0.56	1.00	0.99	0.88	0.85	0.58
	kW*	2.5	2.5	2.5	2.6	2.6	2.6	2.6	2.6	2.6	2.7	2.7	2.7	2.7	2.7	2.8
125	MBh†	17.5	17.6	17.6	19.4	22.1	18.5	18.6	18.0	20.0	22.7	19.4	19.4	18.4	20.4	23.1
	S/T	1.00	0.99	0.82	0.79	0.55	1.00	1.00	0.87	0.83	0.57	1.00	1.00	0.91	0.88	0.60
	kW*	2.8	2.8	2.8	2.8	2.9	2.9	2.9	2.9	2.9	2.9	3.0	3.0	3.0	3.0	3.0

Notes: When the required data fall between the published data, interpolation may be performed. Extrapolation is not an acceptable practice.

† Total capacities are net capacities. Blower heat has been subtracted

†† At TVA rating indoor condition (75 F db/ 63 F wb), All other indoor air temperatures are at 80 F db

* System kW is total unit kW

Key: Standard Rating

S/T are based on 80°F db entering air at the indoor coil. For sensible capacities at other than 80°F db, deduct 835 Btuh per 1000 cfm of indoor coil air from MBhxS/T for each degree below 80°F, or add 835 Btuh per 1000 cfm of indoor coil air from MBhxS/T for each degree above 80°F.

EXPANDED PERFORMANCE DATA (COOLING) - 2-1/2 TON

		PGF330---K--A														
		875					1000					1125				
OD Ambient (°F)	ID Airflow (SCFM)	Entering Indoor Temperature - Degrees F, Wet Bulb														
		57	62	63††	67	72	57	62	63††	67	72	57	62	63††	67	72
75	MBh†	27.0	28.2	28.9	30.7	32.0	28.7	29.1	29.5	31.1	32.9	29.9	29.9	29.9	31.3	33.1
	S/T	0.99	0.91	0.72	0.70	0.50	0.99	0.96	0.75	0.74	0.49	0.99	0.99	0.79	0.78	0.49
	kW*	2.1	2.1	2.1	2.1	2.1	2.2	2.2	2.2	2.2	2.2	2.3	2.3	2.3	2.3	2.3
85	MBh†	25.7	26.4	27.1	30.0	32.4	27.3	27.4	28.0	30.7	32.7	28.7	28.8	28.8	31.2	32.9
	S/T	0.99	0.94	0.74	0.70	0.52	0.99	0.99	0.77	0.74	0.54	0.99	0.99	0.81	0.78	0.56
	kW*	2.3	2.3	2.3	2.3	2.3	2.4	2.4	2.4	2.4	2.4	2.5	2.5	2.5	2.5	2.5
95	MBh†	24.5	24.8	25.4	28.1	31.7	25.9	26.0	26.2	28.6	32.3	27.2	27.3	26.9	29.7	32.6
	S/T	0.99	0.97	0.76	0.72	0.52	0.99	0.99	0.79	0.76	0.54	0.99	0.99	0.83	0.80	0.56
	kW*	2.5	2.5	2.5	2.6	2.6	2.6	2.6	2.6	2.6	2.6	2.7	2.7	2.7	2.7	2.7
105	MBh†	23.2	23.3	23.7	26.3	30.0	24.6	24.7	24.5	27.1	30.9	25.8	25.8	25.0	27.7	31.6
	S/T	0.99	0.99	0.78	0.75	0.53	0.99	0.99	0.82	0.79	0.55	0.99	0.99	0.86	0.83	0.57
	kW*	2.8	2.8	2.8	2.8	2.8	2.8	2.8	2.8	2.9	2.9	2.9	2.9	2.9	3.0	3.0
115	MBh†	21.8	21.9	21.9	24.4	28.0	23.2	23.3	22.6	25.1	28.9	24.3	24.4	23.1	25.7	29.5
	S/T	0.99	0.99	0.81	0.77	0.54	0.99	0.99	0.85	0.82	0.56	0.99	0.99	0.90	0.86	0.59
	kW*	3.0	3.0	3.0	3.1	3.1	3.1	3.1	3.1	3.1	3.2	3.2	3.2	3.2	3.2	3.3
125	MBh†	20.3	20.4	19.8	22.5	26.0	21.6	21.7	20.4	23.2	26.7	22.8	22.8	20.9	23.7	27.3
	S/T	0.99	0.99	0.85	0.80	0.55	0.99	0.99	0.90	0.85	0.58	0.99	0.99	0.95	0.90	0.61
	kW*	3.3	3.3	3.3	3.3	3.4	3.4	3.4	3.4	3.4	3.5	3.5	3.5	3.5	3.5	3.6

EXPANDED PERFORMANCE DATA (COOLING) - 3 TON

		PGF336---K--A														
		1050					1200					1350				
OD Ambient (°F)	ID Airflow (SCFM)	Entering Indoor Temperature - Degrees F, Wet Bulb														
		57	62	63††	67	72	57	62	63††	67	72	57	62	63††	67	72
75	MBh†	32.9	34.1	34.8	37.6	40.5	36.3	36.3	36.7	38.9	41.2	37.4	37.4	37.4	39.2	41.3
	S/T	0.97	0.89	0.84	0.68	0.50	0.97	0.97	0.94	0.75	0.53	0.97	0.97	0.97	0.78	0.55
	kW*	2.4	2.4	2.4	2.4	2.4	2.5	2.5	2.5	2.5	2.6	2.5	2.5	2.6	2.6	2.6
85	MBh†	31.8	32.7	33.3	36.1	39.8	35.0	35.0	35.1	37.7	40.9	36.1	36.2	36.2	38.1	41.1
	S/T	0.97	0.90	0.86	0.69	0.51	0.97	0.97	0.96	0.77	0.54	0.97	0.97	0.97	0.80	0.56
	kW*	2.6	2.6	2.7	2.7	2.7	2.8	2.8	2.8	2.8	2.8	2.8	2.8	2.8	2.9	2.9
95	MBh†	30.7	31.2	31.8	34.5	38.4	33.6	33.6	33.6	35.0	39.7	34.7	34.7	34.7	36.4	40.0
	S/T	0.97	0.93	0.88	0.70	0.51	0.97	0.97	0.97	0.78	0.55	0.97	0.97	0.97	0.82	0.57
	kW*	2.9	2.9	2.9	3.0	3.0	3.0	3.0	3.0	3.1	3.1	3.1	3.1	3.1	3.2	3.2
105	MBh†	29.4	29.7	30.2	32.8	36.7	32.2	32.3	32.3	34.2	38.0	33.2	33.3	33.3	34.6	38.3
	S/T	0.97	0.95	0.90	0.72	0.52	0.97	0.97	0.97	0.81	0.56	0.97	0.97	0.97	0.85	0.59
	kW*	3.2	3.2	3.2	3.3	3.3	3.3	3.4	3.4	3.4	3.5	3.4	3.4	3.4	3.5	3.5
115	MBh†	28.1	28.1	28.5	31.0	34.8	30.7	30.7	30.8	32.2	36.1	31.7	31.7	31.7	32.6	36.4
	S/T	0.97	0.97	0.93	0.74	0.53	0.97	0.97	0.97	0.83	0.58	0.97	0.97	0.97	0.87	0.60
	kW*	3.5	3.5	3.6	3.6	3.7	3.7	3.7	3.7	3.8	3.8	3.8	3.8	3.8	3.8	3.9
125	MBh†	26.6	26.6	26.7	29.1	32.7	29.1	29.1	29.1	30.2	33.9	30.0	30.0	30.0	30.5	34.2
	S/T	0.97	0.97	0.96	0.76	0.54	0.97	0.97	0.97	0.86	0.59	0.97	0.97	0.97	0.91	0.62
	kW*	3.9	3.9	3.9	4.0	4.0	4.0	4.0	4.0	4.1	4.2	4.1	4.1	4.1	4.2	4.3

Notes: When the required data fall between the published data, interpolation may be performed. Extrapolation is not an acceptable practice.

† Total capacities are net capacities. Blower heat has been subtracted

†† At TVA rating indoor condition (75 F db/ 63 F wb), All other indoor air temperatures are at 80 F db

* System kW is total unit kW

Key: Standard Rating

S/T are based on 80°F db entering air at the indoor coil. For sensible capacities at other than 80°F db, deduct 835 Btuh per 1000 cfm of indoor coil air from MBhS/T for each degree below 80°F, or add 835 Btuh per 1000 cfm of indoor coil air from MBhS/T for each degree above 80°F.

EXPANDED PERFORMANCE DATA (COOLING) - 3-1/2 TON

		PGF342---K--A [†]														
		1225					1400					1575				
OD Ambient (°F)	ID Airflow (SCFM)	Entering Indoor Temperature - Degrees F, Wet Bulb														
		57	62	63 ^{††}	67	72	57	62	63 ^{††}	67	72	57	62	63 ^{††}	67	72
75	MBh [†]	38.0	38.8	39.4	42.6	47.0	39.7	39.8	40.3	43.3	47.8	41.0	41.1	41.1	43.9	48.4
	S/T	0.96	0.91	0.86	0.69	0.51	0.96	0.96	0.91	0.73	0.52	0.96	0.96	0.96	0.76	0.54
	kW [*]	2.8	2.8	2.8	2.9	2.9	2.8	2.9	2.9	2.9	3.0	2.9	2.9	3.0	3.0	3.1
85	MBh [†]	36.9	37.3	38.0	41.0	45.3	38.4	38.5	38.8	41.7	46.0	39.7	39.8	39.8	42.2	46.5
	S/T	0.96	0.93	0.88	0.71	0.51	0.96	0.96	0.93	0.74	0.53	0.96	0.96	0.96	0.78	0.55
	kW [*]	3.1	3.1	3.1	3.2	3.2	3.2	3.2	3.2	3.3	3.3	3.2	3.2	3.3	3.4	3.4
95	MBh [†]	35.7	35.9	36.5	39.3	43.5	37.1	37.2	37.3	40.0	44.2	38.3	38.4	38.4	40.4	44.6
	S/T	0.96	0.95	0.90	0.72	0.52	0.96	0.96	0.95	0.76	0.54	0.96	0.96	0.96	0.80	0.56
	kW [*]	3.4	3.5	3.5	3.5	3.6	3.5	3.5	3.5	3.6	3.7	3.6	3.6	3.6	3.7	3.8
105	MBh [†]	34.4	34.4	34.9	37.6	41.7	35.8	35.8	35.9	38.2	42.3	36.9	37.0	37.0	38.6	42.6
	S/T	0.96	0.96	0.92	0.73	0.53	0.96	0.96	0.96	0.77	0.55	0.96	0.96	0.96	0.82	0.57
	kW [*]	3.8	3.8	3.9	3.9	4.0	3.9	3.9	3.9	4.0	4.1	4.0	4.0	4.0	4.1	4.2
115	MBh [†]	33.1	33.1	33.3	35.9	39.7	34.4	34.4	34.4	36.4	40.3	35.4	35.5	35.5	36.7	40.6
	S/T	0.96	0.96	0.94	0.75	0.53	0.96	0.96	0.96	0.79	0.56	0.96	0.96	0.96	0.84	0.58
	kW [*]	4.2	4.3	4.3	4.3	4.4	4.3	4.3	4.3	4.4	4.5	4.4	4.4	4.4	4.5	4.6
125	MBh [†]	31.7	31.7	31.7	34.0	37.7	32.9	32.9	32.9	34.5	38.2	33.9	33.9	33.9	34.8	38.4
	S/T	0.96	0.96	0.96	0.77	0.54	0.96	0.96	0.96	0.82	0.57	0.96	0.96	0.96	0.86	0.59
	kW [*]	4.7	4.7	4.7	4.8	4.9	4.8	4.8	4.8	4.9	5.0	4.9	4.9	4.9	5.0	5.1

Notes: When the required data fall between the published data, interpolation may be performed. Extrapolation is not an acceptable practice.

† Total capacities are net capacities. Blower heat has been subtracted

†† At TVA rating indoor condition (75 F db/ 63 F wb), All other indoor air temperatures are at 80 F db

* System kW is total unit kW

Key: Standard Rating

S/T are based on 80°F db entering air at the indoor coil. For sensible capacities at other than 80°F db, deduct 835 Btuh per 1000 cfm of indoor coil air from MBhxS/T for each degree below 80°F, or add 835 Btuh per 1000 cfm of indoor coil air from MBhxS/T for each degree above 80°F.

EXPANDED PERFORMANCE DATA (COOLING) - 4 TON - High Capacity

		PGF348---K--A [†] (High Capacity)														
		1400					1600					1800				
OD Ambient (°F)	ID Airflow (SCFM)	Entering Indoor Temperature - Degrees F, Wet Bulb														
		57	62	63 ^{††}	67	72	57	62	63 ^{††}	67	72	57	62	63 ^{††}	67	72
75	MBh [†]	42.4	43.6	44.3	47.7	52.3	44.4	44.8	45.3	48.7	53.4	46.0	46.0	46.1	49.5	54.3
	S/T	0.98	0.91	0.72	0.70	0.51	0.98	0.95	0.76	0.73	0.53	0.98	0.98	0.79	0.77	0.55
	kW*	3.6	3.6	3.6	3.6	3.6	3.7	3.7	3.7	3.7	3.7	3.8	3.8	3.8	3.8	3.8
85	MBh [†]	41.2	42.0	42.6	45.9	50.5	43.0	43.2	43.6	46.9	51.5	44.5	44.6	44.4	47.7	52.3
	S/T	0.98	0.92	0.73	0.71	0.52	0.98	0.97	0.77	0.75	0.54	0.98	0.98	0.80	0.78	0.56
	kW*	3.9	3.9	3.9	4.0	4.0	4.0	4.0	4.0	4.0	4.1	4.1	4.1	4.1	4.1	4.2
95	MBh [†]	39.8	40.4	40.9	44.1	48.5	41.6	41.6	41.8	44.5	49.4	43.0	43.1	42.5	45.7	50.2
	S/T	0.98	0.94	0.75	0.72	0.52	0.98	0.98	0.78	0.76	0.54	0.98	0.98	0.82	0.80	0.57
	kW*	4.3	4.3	4.3	4.3	4.4	4.4	4.4	4.4	4.4	4.4	4.5	4.5	4.5	4.5	4.5
105	MBh [†]	38.4	38.7	39.1	42.2	46.4	40.1	40.1	40.0	43.0	47.3	41.4	41.5	40.6	43.7	48.0
	S/T	0.98	0.96	0.76	0.74	0.53	0.98	0.98	0.80	0.78	0.55	0.98	0.98	0.84	0.82	0.58
	kW*	4.7	4.7	4.7	4.7	4.8	4.8	4.8	4.8	4.8	4.9	4.9	4.9	4.9	4.9	4.9
115	MBh [†]	36.9	37.0	37.3	40.2	44.3	38.5	38.5	38.1	41.0	45.1	39.8	39.8	38.7	41.6	45.7
	S/T	0.98	0.98	0.78	0.75	0.54	0.98	0.98	0.82	0.80	0.56	0.98	0.98	0.86	0.84	0.59
	kW*	5.2	5.2	5.2	5.2	5.2	5.2	5.2	5.2	5.3	5.3	5.3	5.3	5.3	5.4	5.4
125	MBh [†]	-	-	-	-	-	-	-	-	-	-	-	-	-	-	-
	S/T	-	-	-	-	-	-	-	-	-	-	-	-	-	-	-
	kW*	-	-	-	-	-	-	-	-	-	-	-	-	-	-	-

EXPANDED PERFORMANCE DATA (COOLING) - 4 TON - Low Capacity

		PGF348---K--A [†] (Low Capacity)														
		950					1100					1250				
OD Ambient (°F)	ID Airflow (SCFM)	Entering Indoor Temperature - Degrees F, Wet Bulb														
		57	62	63 ^{††}	67	72	57	62	63 ^{††}	67	72	57	62	63 ^{††}	67	72
75	MBh [†]	29.4	30.3	30.8	33.1	36.3	30.9	31.1	31.5	33.9	37.1	32.1	32.2	32.2	34.5	37.7
	S/T	0.98	0.90	0.72	0.70	0.51	0.98	0.96	0.76	0.73	0.53	0.98	0.98	0.80	0.77	0.55
	kW*	2.1	2.1	2.1	2.2	2.2	2.2	2.2	2.2	2.2	2.3	2.3	2.3	2.3	2.3	2.4
85	MBh [†]	28.6	29.3	29.8	32.0	35.1	30.0	30.2	30.5	32.7	35.8	31.2	31.3	31.0	33.3	36.4
	S/T	0.98	0.92	0.73	0.71	0.52	0.98	0.97	0.77	0.75	0.54	0.98	0.98	0.81	0.79	0.56
	kW*	2.4	2.4	2.4	2.5	2.5	2.5	2.5	2.5	2.5	2.6	2.6	2.6	2.6	2.6	2.7
95	MBh [†]	27.8	28.2	28.7	30.8	33.8	29.1	29.2	29.4	31.5	34.5	30.2	30.3	29.9	32.0	35.1
	S/T	0.98	0.94	0.74	0.72	0.52	0.98	0.98	0.78	0.76	0.55	0.98	0.98	0.82	0.80	0.57
	kW*	2.8	2.8	2.8	2.8	2.8	2.8	2.8	2.8	2.9	2.9	2.9	2.9	2.9	3.0	3.0
105	MBh [†]	26.9	27.1	27.5	29.6	32.5	28.2	28.2	28.2	30.2	33.1	29.2	29.3	28.7	30.7	33.6
	S/T	0.98	0.95	0.75	0.73	0.53	0.98	0.98	0.80	0.78	0.55	0.98	0.98	0.84	0.82	0.58
	kW*	3.1	3.1	3.1	3.2	3.2	3.2	3.2	3.2	3.2	3.3	3.3	3.3	3.3	3.3	3.3
115	MBh [†]	25.9	26.0	26.3	28.3	31.1	27.1	27.2	26.9	28.9	31.7	28.1	28.2	27.4	29.4	32.1
	S/T	0.98	0.97	0.77	0.75	0.54	0.98	0.98	0.82	0.79	0.56	0.98	0.98	0.86	0.84	0.59
	kW*	3.5	3.5	3.5	3.5	3.6	3.6	3.6	3.6	3.6	3.7	3.7	3.7	3.7	3.7	3.7
125	MBh [†]	24.9	24.9	25.0	26.9	29.6	26.0	26.1	25.6	27.5	30.1	26.9	27.0	26.0	27.9	30.5
	S/T	0.98	0.98	0.79	0.76	0.55	0.98	0.98	0.84	0.81	0.58	0.98	0.98	0.88	0.86	0.60
	kW*	3.9	3.9	3.9	4.0	4.0	4.0	4.0	4.0	4.0	4.1	4.1	4.1	4.1	4.1	4.2

Notes: When the required data fall between the published data, interpolation may be performed. Extrapolation is not an acceptable practice.

† Total capacities are net capacities. Blower heat has been subtracted

†† At TVA rating indoor condition (75 F db/ 63 F wb), All other indoor air temperatures are at 80 F db

* System kW is total unit kW

Key: Standard Rating

S/T are based on 80°F db entering air at the indoor coil. For sensible capacities at other than 80°F db, deduct 835 Btuh per 1000 cfm of indoor coil air from MBh^xS/T for each degree below 80°F, or add 835 Btuh per 1000 cfm of indoor coil air from MBh^xS/T for each degree above 80°F.

EXPANDED PERFORMANCE DATA (COOLING) - 5 TON - High Capacity

		PGF354---K--A [†] (High Capacity)														
		1750					1875					2000				
OD Ambient (°F)	ID Airflow (SCFM)	Entering Indoor Temperature - Degrees F, Wet Bulb														
		57	62	63 ^{††}	67	72	57	62	63 ^{††}	67	72	57	62	63 ^{††}	67	72
75	MBh [†]	52.3	53.1	54.0	58.1	64.2	53.4	53.8	54.6	58.6	64.7	54.3	54.4	55.1	59.0	65.1
	S/T	0.98	0.93	0.88	0.71	0.51	0.98	0.95	0.91	0.73	0.52	0.98	0.97	0.93	0.74	0.53
	kW*	4.4	4.5	4.5	4.7	4.8	4.5	4.5	4.6	4.8	4.9	4.6	4.6	4.7	4.9	5.0
85	MBh [†]	50.7	51.2	52.0	55.8	61.6	51.7	51.9	52.5	56.3	62.1	52.6	52.7	53.0	56.6	62.4
	S/T	0.98	0.94	0.90	0.72	0.52	0.98	0.97	0.92	0.74	0.53	0.98	0.98	0.95	0.76	0.54
	kW*	4.8	4.9	5.0	5.1	5.3	4.9	5.0	5.0	5.2	5.4	5.0	5.0	5.1	5.3	5.5
95	MBh [†]	49.1	49.3	50.0	53.6	59.2	50.0	50.1	50.5	54.0	59.6	50.8	50.9	51.0	54.3	59.9
	S/T	0.98	0.96	0.92	0.73	0.53	0.98	0.98	0.94	0.75	0.54	0.98	0.98	0.96	0.77	0.55
	kW*	5.3	5.4	5.4	5.6	5.8	5.4	5.5	5.5	5.7	5.9	5.5	5.5	5.6	5.8	6.0
105	MBh [†]	47.5	47.5	48.0	51.4	56.7	48.3	48.4	48.5	51.7	57.0	49.1	49.1	49.1	52.0	57.3
	S/T	0.98	0.98	0.94	0.75	0.53	0.98	0.98	0.96	0.77	0.54	0.98	0.98	0.98	0.79	0.55
	kW*	5.9	5.9	6.0	6.1	6.3	6.0	6.0	6.1	6.2	6.4	6.1	6.1	6.1	6.3	6.5
115	MBh [†]	45.7	45.8	46.0	49.1	54.2	46.5	46.6	46.6	49.4	54.5	47.3	47.3	47.3	49.6	54.7
	S/T	0.98	0.98	0.96	0.76	0.54	0.98	0.98	0.98	0.79	0.55	0.98	0.98	0.98	0.81	0.56
	kW*	6.5	6.5	6.6	6.7	6.9	6.6	6.6	6.7	6.8	7.0	6.7	6.7	6.7	6.9	7.1
125	MBh [†]	-	-	-	-	-	-	-	-	-	-	-	-	-	-	-
	S/T	-	-	-	-	-	-	-	-	-	-	-	-	-	-	-
	kW*	-	-	-	-	-	-	-	-	-	-	-	-	-	-	-

EXPANDED PERFORMANCE DATA (COOLING) - 5 TON - Low Capacity

		PGF354---K--A (Low Capacity)														
		1150					1300					1500				
OD Ambient (°F)	ID Airflow (SCFM)	Entering Indoor Temperature - Degrees F, Wet Bulb														
		57	62	63 ^{††}	67	72	57	62	63 ^{††}	67	72	57	62	63 ^{††}	67	72
75	MBh [†]	37.6	38.9	39.6	42.8	47.3	39.3	39.9	40.5	43.7	48.3	41.1	41.2	41.6	44.6	49.3
	S/T	0.98	0.89	0.85	0.69	0.51	0.98	0.93	0.89	0.72	0.52	0.98	0.98	0.94	0.75	0.54
	kW*	3.6	3.6	3.6	3.7	3.7	3.7	3.7	3.7	3.7	3.7	3.7	3.7	3.7	3.8	3.8
85	MBh [†]	36.5	37.4	38.1	41.3	45.7	38.1	38.4	39.1	42.1	46.6	39.9	39.9	40.1	43.0	47.5
	S/T	0.98	0.91	0.86	0.70	0.51	0.98	0.95	0.91	0.73	0.53	0.98	0.98	0.96	0.77	0.55
	kW*	3.6	3.7	3.7	3.7	3.7	3.7	3.7	3.7	3.7	3.7	3.7	3.7	3.7	3.8	3.8
95	MBh [†]	35.3	35.9	36.6	39.6	44.0	36.8	36.9	37.5	40.4	44.8	38.5	38.6	38.6	41.2	45.6
	S/T	0.98	0.93	0.88	0.71	0.52	0.98	0.97	0.93	0.74	0.53	0.98	0.98	0.98	0.78	0.56
	kW*	3.6	3.7	3.7	3.7	3.7	3.7	3.7	3.7	3.7	3.7	3.7	3.7	3.7	3.8	3.8
105	MBh [†]	34.1	34.4	35.0	37.9	42.1	35.5	35.6	35.9	38.7	42.9	37.1	37.2	37.2	39.4	43.7
	S/T	0.98	0.95	0.90	0.72	0.53	0.98	0.98	0.95	0.76	0.54	0.98	0.98	0.98	0.80	0.57
	kW*	3.7	3.7	3.7	3.7	3.7	3.7	3.7	3.7	3.7	3.7	3.7	3.7	3.7	3.8	3.8
115	MBh [†]	32.8	32.9	33.4	36.2	40.3	34.2	34.2	34.3	36.9	41.0	35.7	35.7	35.7	37.6	41.6
	S/T	0.98	0.97	0.92	0.74	0.53	0.98	0.98	0.97	0.77	0.55	0.98	0.98	0.98	0.82	0.58
	kW*	3.7	3.7	3.7	3.7	3.7	3.7	3.7	3.7	3.8	3.8	3.8	3.8	3.8	3.8	3.8
125	MBh [†]	31.5	31.6	31.9	34.4	38.3	32.8	32.8	32.9	35.1	39.0	34.2	34.2	34.2	35.7	39.6
	S/T	0.98	0.98	0.95	0.76	0.54	0.98	0.98	0.98	0.79	0.56	0.98	0.98	0.98	0.85	0.59
	kW*	3.7	3.7	3.7	3.7	3.7	3.7	3.7	3.7	3.8	3.8	3.8	3.8	3.8	3.8	3.8

Notes: When the required data fall between the published data, interpolation may be performed. Extrapolation is not an acceptable practice.

† Total capacities are net capacities. Blower heat has been subtracted

†† At TVA rating indoor condition (75 F db/ 63 F wb), All other indoor air temperatures are at 80 F db

* System kW is total unit kW

Key: Standard Rating

S/T are based on 80°F db entering air at the indoor coil. For sensible capacities at other than 80°F db, deduct 835 Btuh per 1000 cfm of indoor coil air from MBh[†]S/T for each degree below 80°F, or add 835 Btuh per 1000 cfm of indoor coil air from MBh[†]S/T for each degree above 80°F.

ACCESSORIES

ROOF CURBS

Model Number	Height (K)	Use With
ACL01FB0A	8"	PGF324, PGF330, PGF336, PGF342
ACM01FB0A	14"	
ACH01FB0A	24"	
ACL02FB0A	8"	PGF348 PGF354
ACM02FB0A	14"	
ACH02FB0A	24"	

ROOF CURB DIMENSIONS (inches)

Model Number	A	B	C	D	E	F	G	H	K (ACL)	K (ACM)	K (ACH)
AC(L,M,H)01FB0A	42-1/2	39-1/2	16	21-1/2	2	45-3/4	42-3/4	20	8	14	24
AC(L,M,H)02FB0A	44-3/4	41-3/4	18-7/8	20-7/8	2	45-3/4	42-3/4	22	8	14	24

NOTE: AXB020(L,M,H)A curb can be substituted for AC(L,M,H)01FB0A.

SQUARE to ROUND TRANSITION

Model Number	Round Size	Use With Roof Curb
ACT01FB0A	16"	ACL01FB0A, ACM01FB0A, ACH01FB0A
ACT02FB0A	18"	ACL02FB0A, ACM02FB0A, ACH02FB0A

CONCENTRIC GRILLE - FLUSH MOUNT

Model Number	Use With Roof Curb
AXB020CFA	ACL01FB0A, ACM01FB0A, ACH01FB0A
AXB030CFA	ACL02FB0A, ACM02FB0A, ACH02FB0A

CONCENTRIC GRILLE - STEP DOWN

Model Number	Use With Roof Curb
AXB020CSA	ACL01FB0A, ACM01FB0A, ACH01FB0A
AXB030CSA	ACL02FB0A, ACM02FB0A, ACH02FB0A

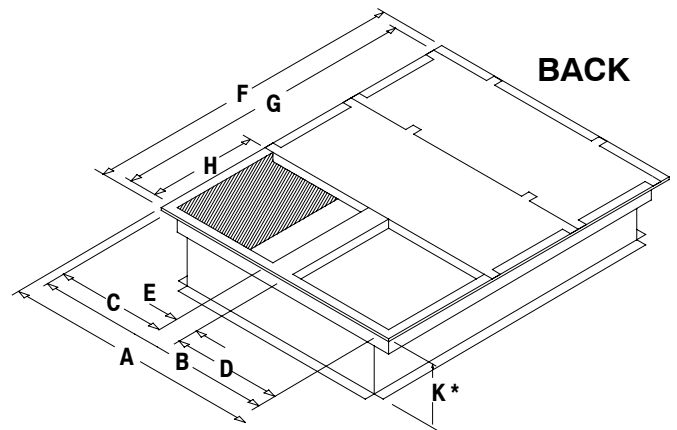

Curb Dimensions

Roof Curbs available in 8", 14" and 24" Heights (K Dimensions)

ECONOMIZERS (ALL FULLY MODULATING)*

Model Number	Application	Motion	Control	Use With Model Size
AHE01FB0A	Horizontal	Fully Modulating w/ Return Air Damper w/ Relief Damper	Enthalpy	24
AHE02FB0B				30, 36, 42, 48, 54
AEM01FB0A	Downflow			24
AEM03FB0B				30, 36, 42
AHP01FB0B	Horizontal	Fully Modulating w/ Return Air Damper w/ Relief Damper	Dry Bulb Only	24
AHP02FB0B				30, 36, 42, 48, 54
AEP01FB0B	Downflow			24
AEP03FB0B				30, 36, 42

* Three position economizers no longer available.

0% - 35% FRESH AIR DAMPERS (use in DOWNFLOW application only) *

Model Number	Control	Use With Model Size
AFA01FB0A	Manual	24
AFA02FB0A		30, 36, 42, 48, 54
AFM01FB0A	Motorized	24
AFM02FB0A		30, 36, 42, 48, 54

* Unit must have internal filters to protect evaporator coil when Fresh Air Damper is installed.

ACCESSORIES (CONT.)

FILTER KIT, INTERNAL (use in HORIZONTAL or DOWNFLOW application)

Model Number	Filter Size (filters NOT supplied in kit)	Use With Model Size
AKF12FB0A	12 x 25 x 1 (2 required)	24
	14 x 25 x 1 (2 required)	30, 36, 42, 48, 54

HAIL GUARD

Model Number	Use With Model Size
AGH01FB0A	24
AGH02FB0A	30, 36, 42, 48, 54

LOW AMBIENT CONTROL

Model Number	FAST Part Number	Use With
ALA12CU0A	1085493	ALL

CONVERSION KITS

NATURAL GAS TO LP CONVERSION

MEAN ELEVATION FEET ABOVE SEA LEVEL

Nominal Heating Size	0 to 2000		2001 to 4000		4001 to 7000		7001 to 9000		9001 to 10,000	
	Orifice Drill #	Kit #	Orifice Drill #	Kit #	Orifice Drill #	Kit #	Orifice Drill #	Kit #	Orifice Drill #	Kit #
040, 060, 080	55	1173857	55	1173857	56	1173859	56	1173859	57	1173861
100, 120, 140	54	1173855	55	1173857	55	1173857	56	1173859	56	1173859

LP TO NATURAL GAS CONVERSION

MEAN ELEVATION FEET ABOVE SEA LEVEL

Nominal Heating Size	0 to 2000		2001 to 4000	4001 to 5000	5001 to 6000	6001 to 7000	7001 to 8000	8001 to 9000	9001 to 10000
	Orifice Drill #	Kit #	Orifice Drill #						
040, 060, 080	44	1173863	45	46	47	47	48	48	49
100	41	1173865	43	43	43	44	44	45	46
120, 140	42	1173865	43	43	44	44	45	46	47

UNIT DIMENSIONS

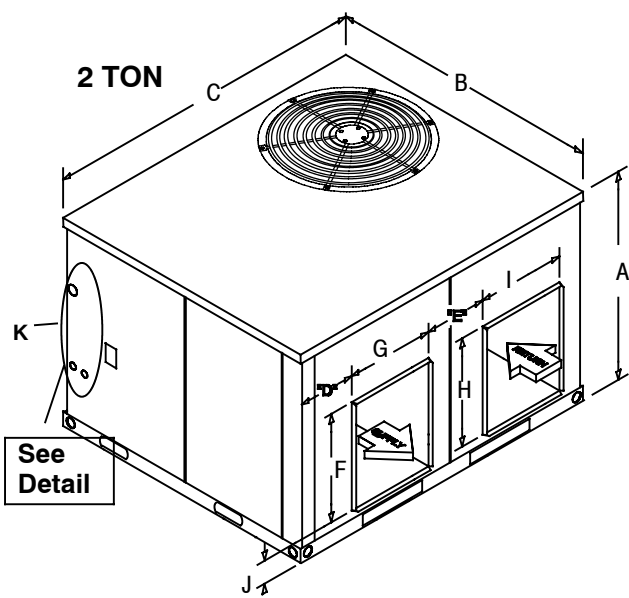

2-1/2 TO 5 TON

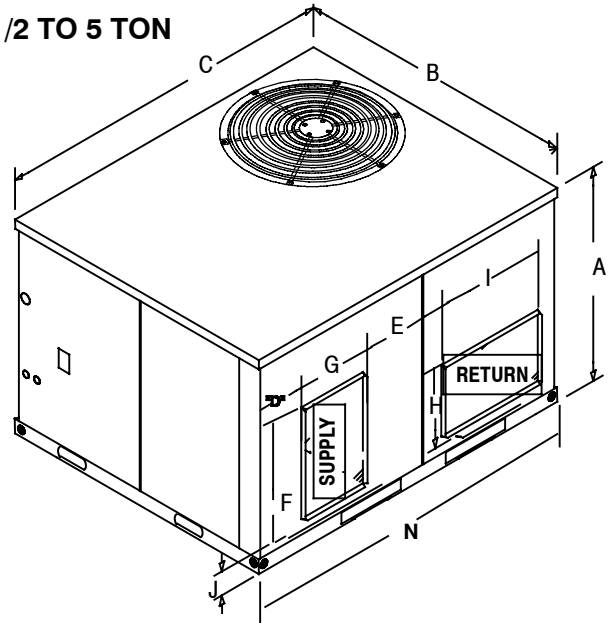

BASE PAN - CHASSIS

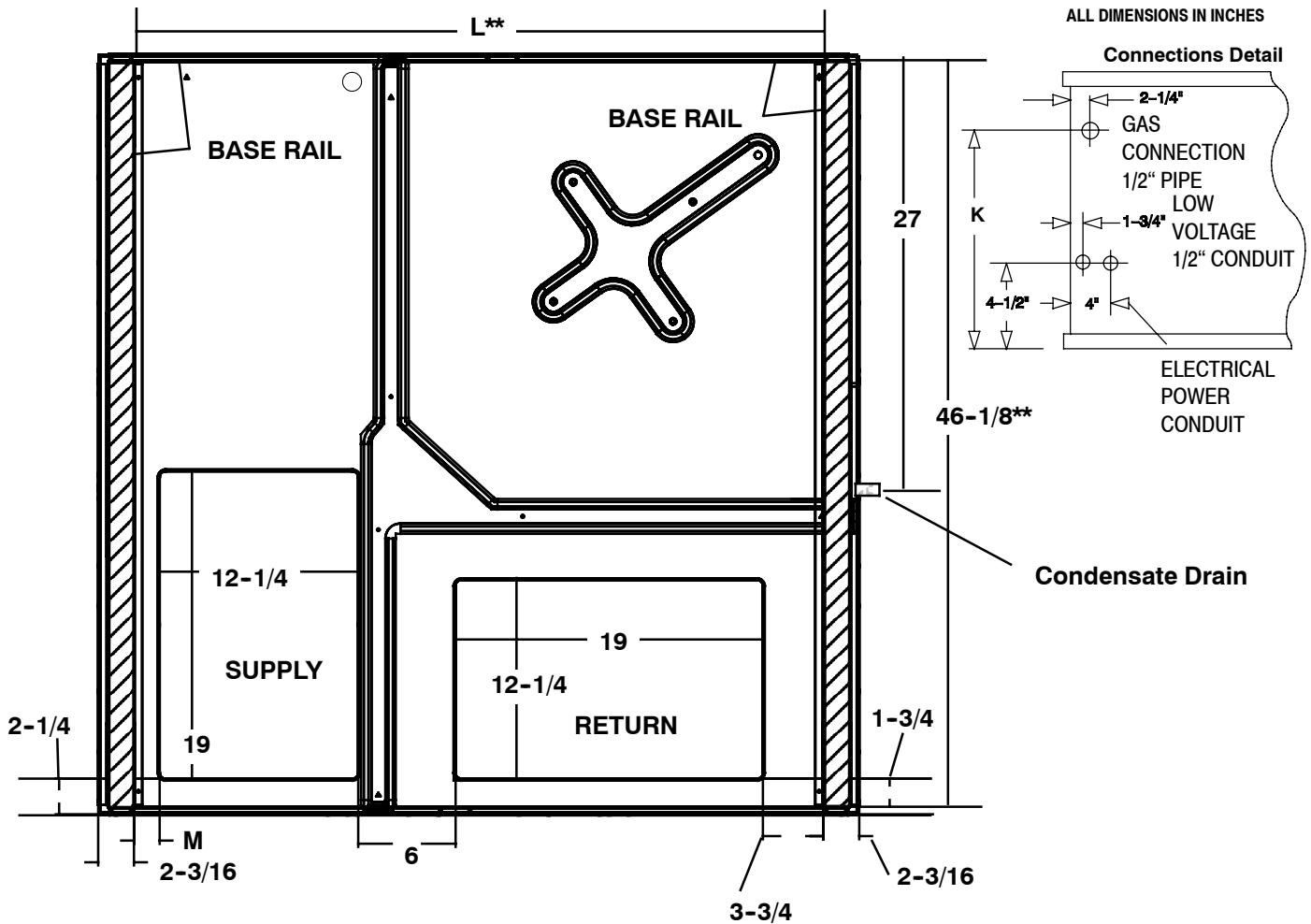

UNIT SIZE	A	B	C	D	E	F	G	H	I	J	K	L	M	N
2 Ton	29-1/2	47-1/2	47-1/2	3	9-1/2	12	14	12	14	4-1/2	16	42-3/4	1-9/16	46-1/2
2-1/2 TO 3-1/2 Ton	37-1/2	47-1/2	47-1/2	3-1/2	6-1/2	19	12	12	19	4-1/2	21-1/2	42-3/4	1-9/16	46-1/2
4 TO 5 Ton *	37-1/2	47-1/2	51	7-1/2	6-1/2	19	12	12	19	4-1/2	21-1/2	46-1/4	5-3/16	49-3/4

** Measured from inside to inside on base rails.

MODEL NUMBER IDENTIFICATION GUIDE

Product Family	SEER	Nominal Cooling Capacity Btuh	Heating Input Btuh	Voltage	Option Code	Design Code	Eng. Rev. Code
PGF - Package Gas/Electric	3 = 13	24 = 24,000	000 = N/A	K = 208/230-1-60	00 = Nat 01 = Lo Nox	A	1
		30 = 30,000	040 = 40,000				
		36 = 36,000	060 = 60,000				
		42 = 42,000	080 = 80,000				
		48 = 48,000	100 = 100,000				
		54 = 54,000	120 = 120,000				
		140 = 140,000					
Example: PGF	3	24	060	K	00	A	1

GUIDE SPECIFICATION

CABINET

The cabinet is made of triple-coated steel, consisting of a Polyester top coat, a urethane primer coat preceded by an oxide pretreatment. One piece weather resistant top. The base rails are 16 gauge steel with fork lift slots and holes provided for lifting shackles. The unit is designed with convertible airflow for either horizontal or downflow applications with conversion accomplished by relocating two panels. Indoor blower compartment interior cabinet surfaces are insulated with a minimum 1/2" thick, flexible glass insulation, coated on the air side. Aluminum foil faced glass fiber insulation is used in the furnace compartment.

COOLING SECTION

The unit is factory charged and operationally ready upon delivery. The unit refrigerant circuit has a high efficiency scroll compressor with internal overload protection, and copper tube / aluminum fin evaporator and condenser coils. The unit is designed for cooling operation to 40° F and will be capable of being wired for field installed economizer type accessories.

COILS

The evaporator and condenser coils are fabricated with aluminum fins mechanically bonded to copper tubing. Both coils are pressure tested prior to assembly into the unit and electronically leak tested after assembly into the unit.

CONDENSER FAN

The unit has a single direct-drive propeller-fan / motor assembly. The assembly is mounted directly to a vertical-discharge grille that is easily removed for service. Motors are 1100 RPM with sleeve or ball bearings and internal overload protection.

EVAPORATOR BLOWER

All units have a direct-drive evaporator blower motor as a standard. The direct-drive evaporator blower motor has sleeve bearings and internal overload protection.

HEATING SECTION

The gas-fired heating section features an induced draft blower for combustion air. The unit has an aluminized steel serpentine clamshell heat exchanger located on the discharge air side of the blower. The system uses in-shot burners ignited by a hot surface pilot ignition system, protected by both a high heat limit switch and flame roll-out switch. The induced draft blower motor is interlocked with a proven air pressure safety device.

RIGGING DETAILS

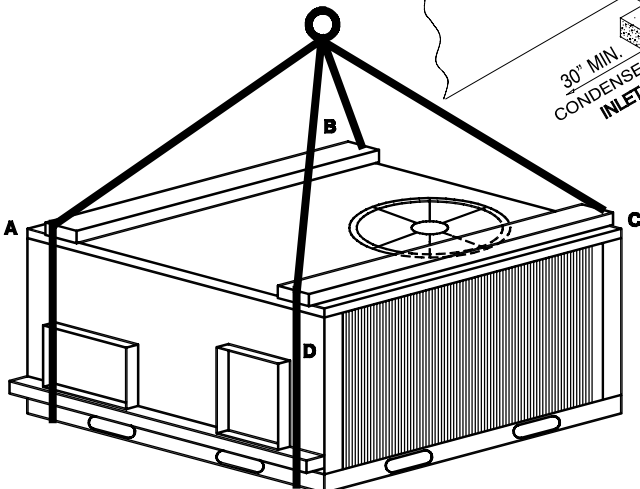

INSTALLATION CLEARANCES

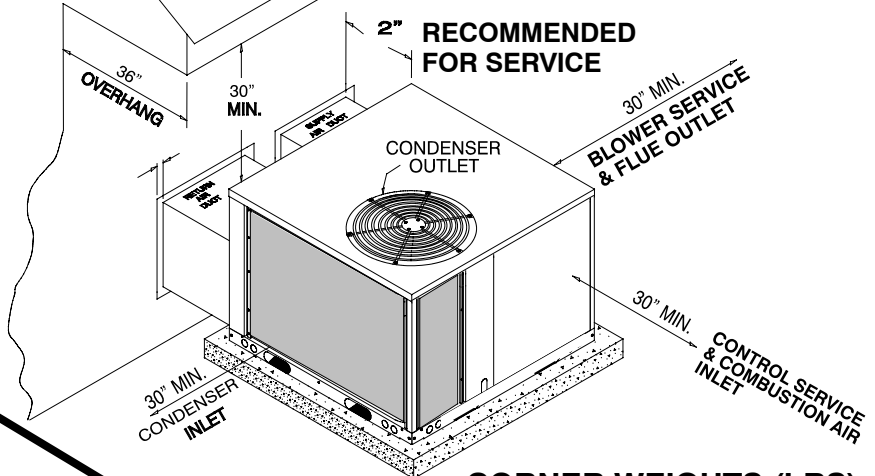

CORNER WEIGHTS (LBS)

UNIT SIZE	A	B	C	D	OPERATING WEIGHT TOTAL
2 TON					338
2-1/2 TON					327
3 TON					344
3-1/2 TON					420
4 TON					490
5 TON					500