

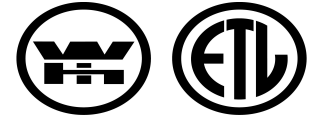

INSTALLATION INSTRUCTIONS

CEILING RADIATION DAMPERS ETL CLASSIFIED UL263/E119
 FOR USE IN WOOD TRUSS ASSEMBLIES
 UL DESIGN NUMBERS L550, L562, L574, L579, L585, M503,
 P531, P538, P545, P552, L528, L530, L570, L521, L546, L563,
 P522, P533, L586, P548 **MODELS: 557RD AND 557RDD**



Intertek

- | | |
|---|--|
| (A) Duct board plenum | (G) RC Channel |
| (B) Steel frame Grille/Diffuser, 26 ga. minimum, see note 6 | (H) Sub-frame with plaster flange |
| (C) 3/4" x 3/4" x 16 ga. Support Angle (2 sides) or STD 100326 Boot Rail, see notes 2 & 3 | (I) Flanged sleeve or 1" x 1" x 20 ga. Retaining Angle (min.) on all 4 sides |
| (D) Flex Duct ETL/ UL Classified Air Duct (Class 0 or 1) | (J) Air Duct over air handler unit |
| (E) Wood Truss (refer to specific UL Design No.) | (K) Ceiling Damper (1 or 2 blades) |
| (F) 5/8" Gypsum Wallboard (refer to specific UL Design No.) | |

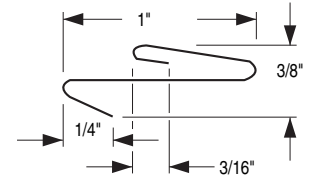

Standard Boot Rail

Alternate installation using standard boot rail. Damper may be installed using standard boot rail. Rails to be installed on opposite sides of boot and attached to the bottom cord of the truss using 16D nails or screws a minimum of 1 1/2" long.

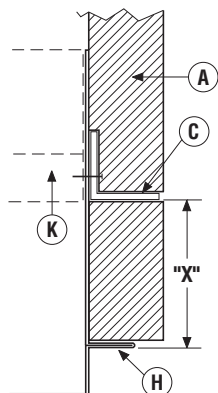

DETAIL A

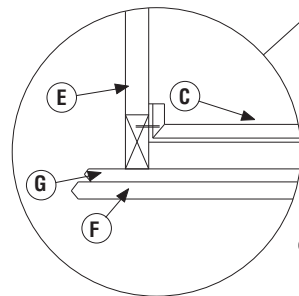

DETAIL B

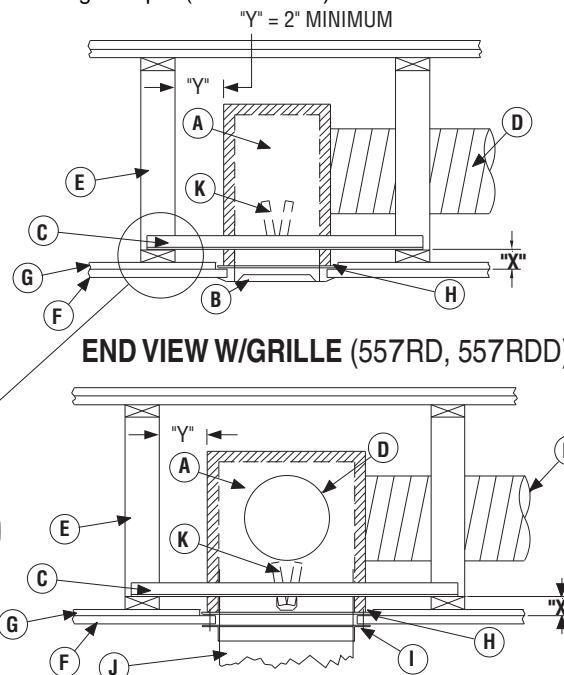

END VIEW W/GRILLE (557RD, 557RDD)

END VIEW W/DUCT (557RDD, 557RDD)

NOTES:

- Before installing, open damper blades and install fusible link between spring loaded wire clips. Do not bend or deform clips after assembly. If dampers are provided with link tabs instead of wire clips, install link and bend tabs to secure link in position.
- Attach 26 ga boot rails or 3/4" x 3/4" x 16 ga. support angles to sub-frame with a minimum of two #8 screws or 3/16" dia. steel pop rivets or spot welds each side. Distance from bottom of angle to bottom of plaster flange (X) should be the combined thickness of the wood truss member and the RC channel (See Detail A). Alternate boot rail installation instructions at top of page.
Make sure fasteners do not interfere with damper operation.
- Install assembly between trusses as shown in End View and attach support angles to truss lower members using 1 1/4" long type S steel screws or similar. See Detail B for alternate support angle attachment method. Minimum clearance (Dimension "Y") between damper assembly and wood truss is 2".
- Ceiling penetrations should be located between adjacent trusses and RC channels. If required, a maximum of one RC channel may be cut or notched to enable proper damper location. The clearance between the damper assembly and the cutout in the ceiling material shall be a maximum of 1/8" on any side.
- Flex duct shall be ETL OR UL Classified Air Duct Class 0 or Class 1 and shall be attached to the plenum collar with steel clamps, plastic straps, or minimum 18 gauge steel wire.
- The grille/diffuser frame shall be 26 gauge minimum steel and shall be attached with a minimum of two #8 x 1 1/4" min. screws through the ceiling material and into the plaster flange.
- Refer to UL Fire Resistance Directory Vol. I for details on UL Floor/Ceiling Design No.s L550, L562, L574, L579, L585, M503, L563, L546, L521, L528, L530, L570 and Roof/Ceiling Design No.s P531, P538, P545, P552, P533, P522. 1 Hour Fire Rating.

Dimensions are in inches

MODELS: 557RD, 557RDD