

# INSTALLATION INSTRUCTIONS

## LOW AMBIENT CONTROL PACKAGE RXRZ-B01 2 THROUGH 4 TON R-410A UNITS

### Package Air Conditioners Package Gas Electric Units

**⚠** Recognize this symbol as an indication of Important Safety Information!

#### ⚠ WARNING

*THIS ACCESSORY IS INTENDED TO BE INSTALLED BY A QUALIFIED, LICENSED SERVICE PERSON. TO AVOID UNSATISFACTORY OPERATION OR DAMAGE TO THE PRODUCT AND POSSIBLE UNSAFE CONDITIONS, INCLUDING ELECTRICAL SHOCK, REFRIGERANT LEAKAGE AND FIRE WHICH CAN RESULT IN PROPERTY DAMAGE, PERSONAL INJURY OR DEATH. THE INSTALLATION INSTRUCTIONS PROVIDED WITH THIS ACCESSORY MUST BE STRICTLY FOLLOWED AND THE PARTS SUPPLIED USED WITHOUT SUBSTITUTION. DAMAGE TO THE PRODUCT RESULTING FROM NOT FOLLOWING THE INSTRUCTIONS OR USING UNAUTHORIZED PARTS MAY BE EXCLUDED FROM THE MANUFACTURER'S PRODUCT WARRANTY COVERAGE.*

PARTS LIST		
Description	Part Number	Quantity
Low Ambient Pressure Control	47-100571-02	1
Bracket	AE-56928-01	1
Adapter	83-21457-02	1
Wire Nut	45-18058-01	2
Wire Tie	64-17606-01	4
Screw #8 x 1/2	63-22153-01	3
Installation Instructions	92-22046-12	1

#### ⚠ WARNING

**BEFORE BEGINNING ANY MODIFICATION, BE SURE THE MAIN ELECTRICAL DISCONNECT SWITCH IS IN THE "OFF" POSITION. FAILURE TO DO SO CAN CAUSE ELECTRICAL SHOCK RESULTING IN PROPERTY DAMAGE, PERSONAL INJURY OR DEATH.**

#### ⚠ CAUTION

**When making flare connections, use a back-up wrench to avoid breaking connection or splitting flare.**

#### I. INSTALLING LOW AMBIENT CONTROL WITHOUT HIGH PRESSURE CONTROL BEING INSTALLED.

- A. Remove condenser fan and cover assembly from top of condenser section.
- B. Remove control box cover.
- C. Secure the low ambient control to the bracket provided, using (2) wire ties. (Refer to Figure 1.)
- D. Remove existing screw located at the top of the condenser section side panel close to the control box. (Refer to Figure 2.) Install the bracket and control assembly using existing screw.
- E. Remove cap from liquid line service port under condenser fan. Install cap on service port end (with valve core) of adapter provided.

**NOTE:** If a high pressure control is to be installed at this time, the valve core needs to be removed from the adapter and the control attached in place of the cap. Refer to installation instructions for the high pressure control.

- F. Connect tubing from control to end of adapter tee without valve core.
- G. Carefully route control tubing to make sure it doesn't come in contact with vibrating parts that could cause damage and connect tee to high side service port.

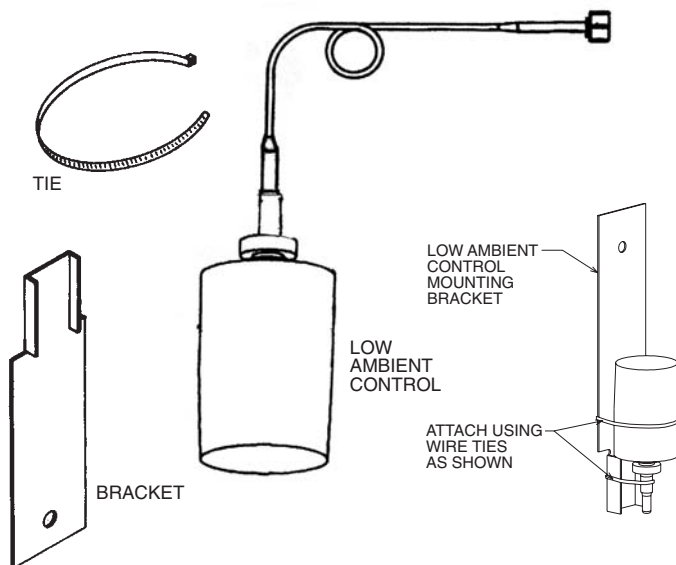

**LOW AMBIENT CONTROL ASSEMBLY  
FIGURE 1**

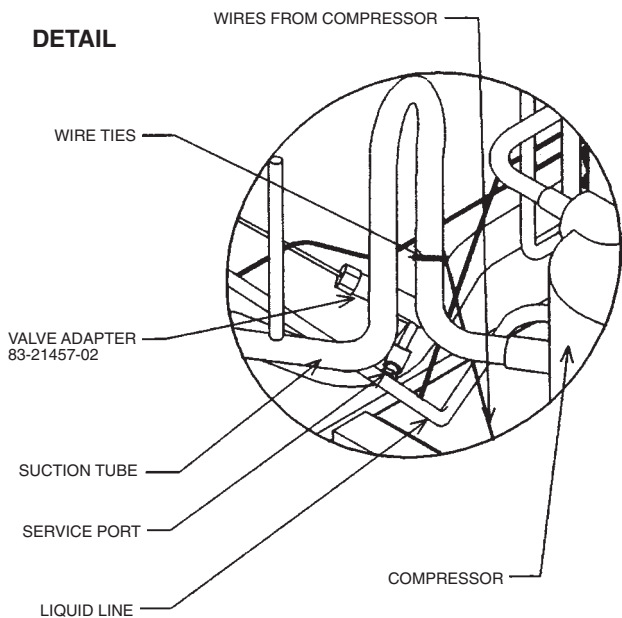
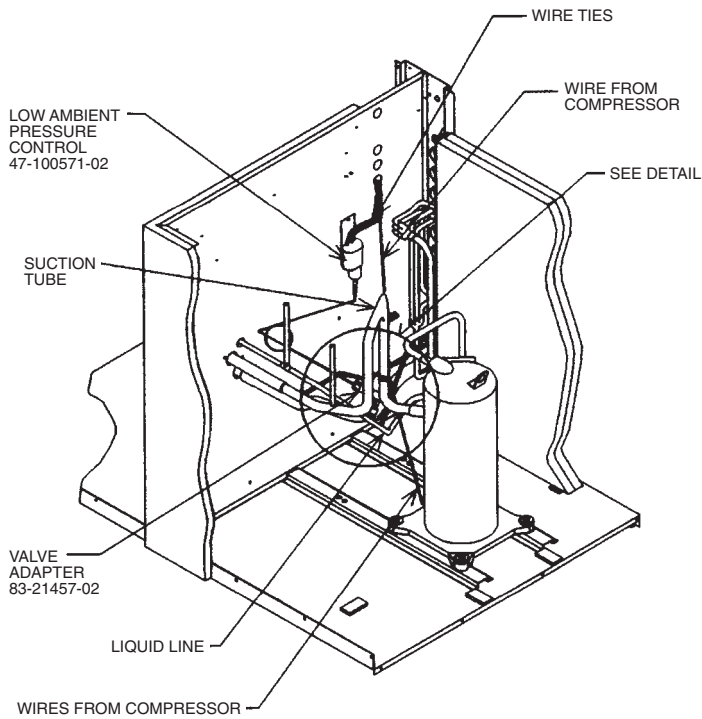
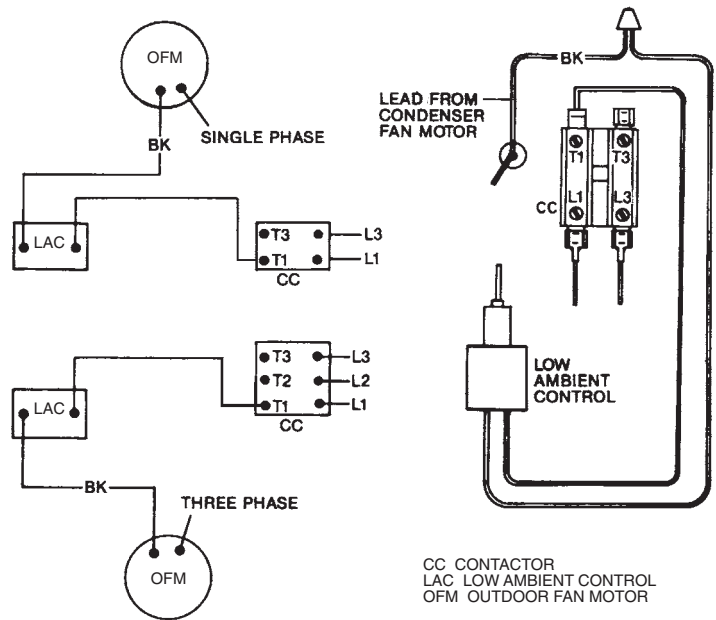

**FIGURE 2. LOW AMBIENT CONTROL INSTALLATION**

H. Check all connections for refrigerant leaks and repair as necessary.

## II. ELECTRICAL CONNECTIONS

- A. Route leads from low ambient control up through the plastic bushing installed in the upper condenser bulkhead to the area behind the control box. From this point route the wires through the opening in the left side of the control box.
- B. Disconnect black lead from fan motor at T1 on contactor. (Refer to Figure 3.) Connect low ambient control lead with flat terminal to T1 on contactor.



**FIGURE 3. LOW AMBIENT CONTROL WIRING**

- C. Remove terminal from fan motor black lead and strip the insulation back 1/2" from end of wire.
- D. Connect the black lead from fan motor to the stripped lead from control using wire nut provided.
- E. Secure leads from control to a convenient wire bundle using the wire tie provided in package.
- F. Reinstall condenser fan assembly and control box cover.
- G. Restore power to the unit and check unit operation.

## III. UNIT CHECK

- A. Restore power and check unit for proper operation.
- B. Outdoor fan cycles off when liquid pressure drops below  $250, \pm 10$  PSIG.
- C. Outdoor fan cycles on when liquid pressure rises above  $450, \pm 10$  PSIG.

This accessory is used when unit operation is required during low ambient conditions. Installation of this control provides a means of de-energizing the condenser fan motor. This permits the suction (low side) to remain above the point which can cause icing of evaporator (inside coil).

I513