

INSTRUCTIONS FOR (-)XRF-KDA1 MANUAL FRESH AIR DAMPER (-)XRX-AW02 MOTORIZED AND FRESH AIR DAMPER KIT

⚠ Recognize this symbol as an indication of Important Safety Information!

⚠ WARNING

THESE INSTRUCTIONS ARE INTENDED AS AN AID TO QUALIFIED, LICENSED SERVICE PERSONNEL FOR PROPER INSTALLATION, ADJUSTMENT AND OPERATION OF THIS UNIT. READ THESE INSTRUCTIONS THOROUGHLY BEFORE ATTEMPTING ADJUSTMENT OR OPERATION. FAILURE TO FOLLOW THESE INSTRUCTIONS CAN RESULT IN IMPROPER INSTALLATION, ADJUSTMENT; SERVICE OR MAINTENANCE, POSSIBLY RESULTING IN FIRE, ELECTRICAL SHOCK, PROPERTY DAMAGE, PERSONAL INJURY OR DEATH.

⚠ WARNING

TURN OFF ELECTRIC POWER TO THE UNIT BEFORE ATTEMPTING ANY MAINTENANCE. FAILURE TO DO SO CAN CAUSE ELECTRICAL SHOCK RESULTING IN PERSONAL INJURY OR DEATH.

1. Remove (4) screws from each side of the unit top cover.
2. Remove all screws from top left panel (retain screws and top left panel for later use).
3. Lift top cover high enough to replace top left panel with damper panel assembly.
4. Replace top left panel with (A) damper panel assembly.
5. Secure the (B) hood sides to the edges of the (A) damper panel assembly with (6) screws removed in step 2.
6. Adjust damper slide to appropriate opening now.
7. Trap (C) filters between (C) front filter support and filter support on the (A) damper assembly while attaching to the (B) hood side with (3) screws provided.
8. Attach (D) rain hood (previously the top left panel) to the (B) hood side with (4) screws each side, (6) screws between rain hood and front filter support.
9. Attach (E) rain hood top to the same location as upper edge of (A) damper panel assembly with (6) screws that were removed in step 2.
10. Secure (E) rain hood top to rain hood and hood side with (8) screws provided.
11. Secure all remaining screws, making sure that all weather exposed screw holes use the screws.

NOTE:

○ — CIRCLED LETTERS EQUAL ORDER OF INSTALLATION

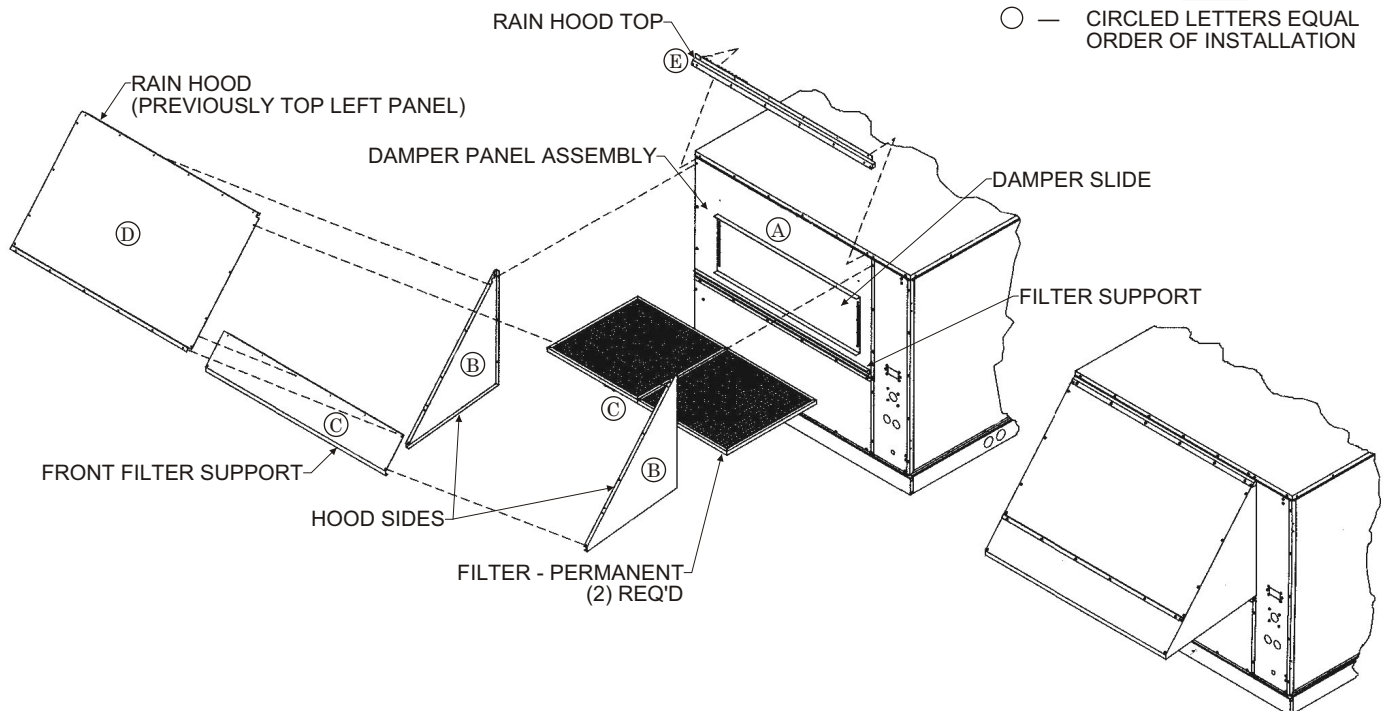

IF UNIT HAS AN EXISTING MANUAL FRESH AIR DAMPER

Refer to page 1. Reverse assembly procedure until damper panel assembly is removed. Assemble motorized damper assembly (see (F) below). Then reassemble fresh air damper using motorized damper assembly.

IF UNIT HAS NO EXISTING MANUAL FRESH AIR DAMPER

1. Assemble motorized damper panel assembly by removing the damper slide from damper panel assembly, then attaching the (F) motorized damper to the opposite side. Use (6) of the screws from the damper slide to attach the motorized damper.
2. Remove (4) screws from top cover sides.
3. Remove all screws from top left panel (retain screws and top left panel for later use).

4. Lift top cover and remove top left panel. Plug power cord for motorized damper into polarized wire harness connector.
5. Apply power to unit and set minimum damper position with adjustment wheel on damper motor.
6. Secure the (B) hood sides to the edges of the (A) motorized damper panel assembly with (6) screws removed in step 3.
7. Trap (C) filters between (C) front filter support and filter support on the (A) damper assembly while attaching to the (B) hood side with (3) screws provided.
8. Attach (D) rain hood (previously the top left panel) to the (B) hood side with (4) screws each side, (6) screws between rain hood and front filter support.
9. Attach (E) rain hood top to the same location as upper edge of (A) damper panel assembly with (6) screws that were removed in step 3.
10. Secure (E) rain hood top to rain hood and hood side with (8) screws provided.
11. Secure all remaining screws, making sure that all weather exposed screw holes use the screws.

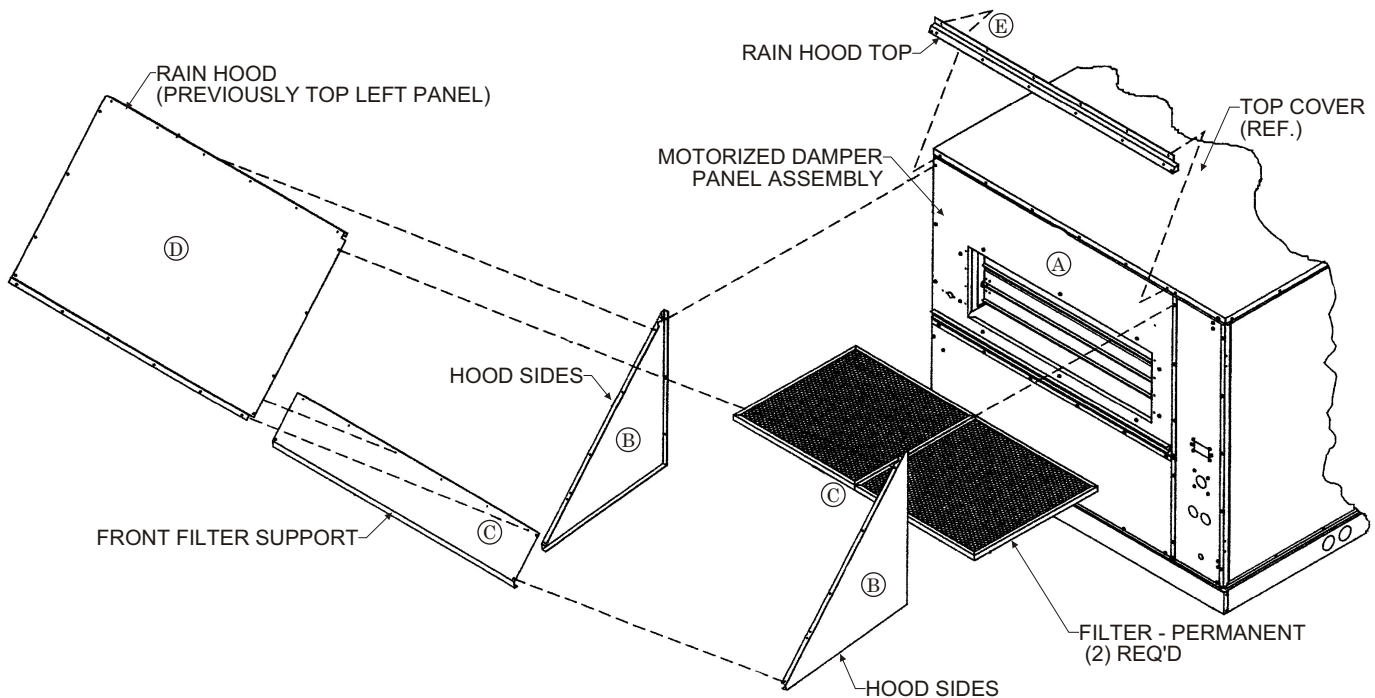
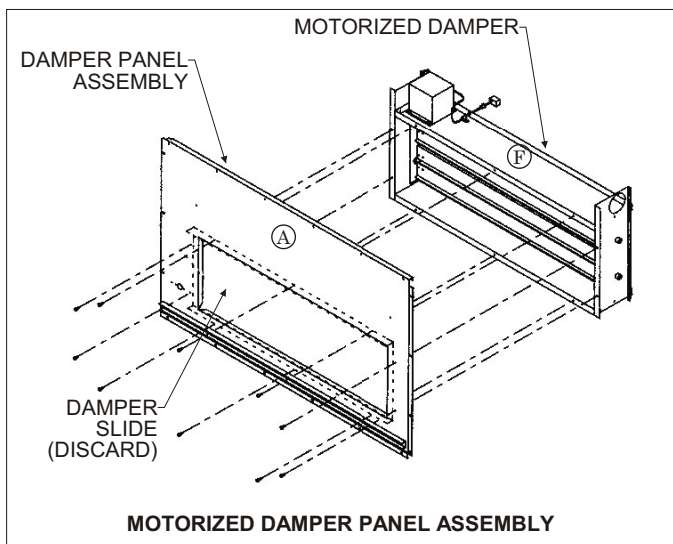

TO ADJUST DAMPER MINIMUM POSITION

1. Remove return air cover.
2. Apply power to unit.
3. Supply fan **must** be on.
4. Turn potentiometer wheel on damper motor to adjust damper minimum position,
5. After successfully adjusting damper position, replace return air cover.

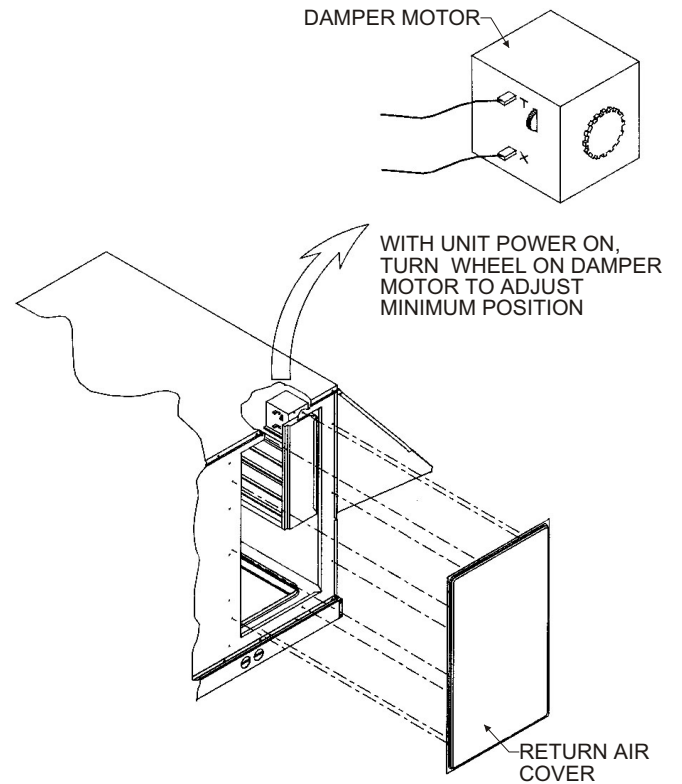

FOR HORIZONTAL AIR FLOW INSTALLATIONS

1. Installer must provide opening in return air duct with removable cover for access to minimum position adjustment on motorized damper.
2. Remove cover on return air duct.
3. Apply power to unit.
4. Supply fan **must** be on.
5. Turn potentiometer wheel on damper motor to adjust damper minimum position.
6. After successfully adjusting damper position, replace cover on return air duct.

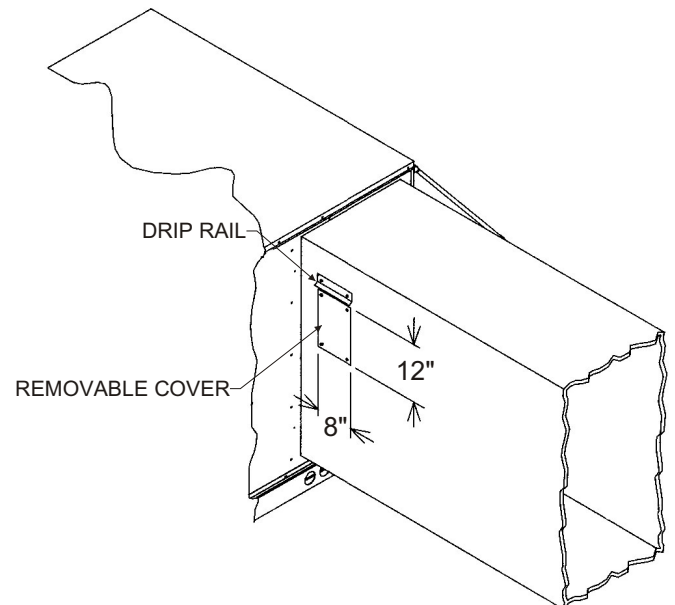

HARNES ENDS AT PL6 & PL7

COMPONENT CODE

Economizer
 M8405A Damper Actuator 24v
 PL6 Male A/C Unit Plug
 PL7 Female A/C Unit Plug
 PL20 Female Damper Plug
 PL21 Male Smoke Plug

WIRE COLOR CODE

BLK Black BLU Blue
 BRN Brown GRY Gray
 ORG Orange RED Red
 VIO Violet WHT White
 YEL Yellow

Revision	Change	Date

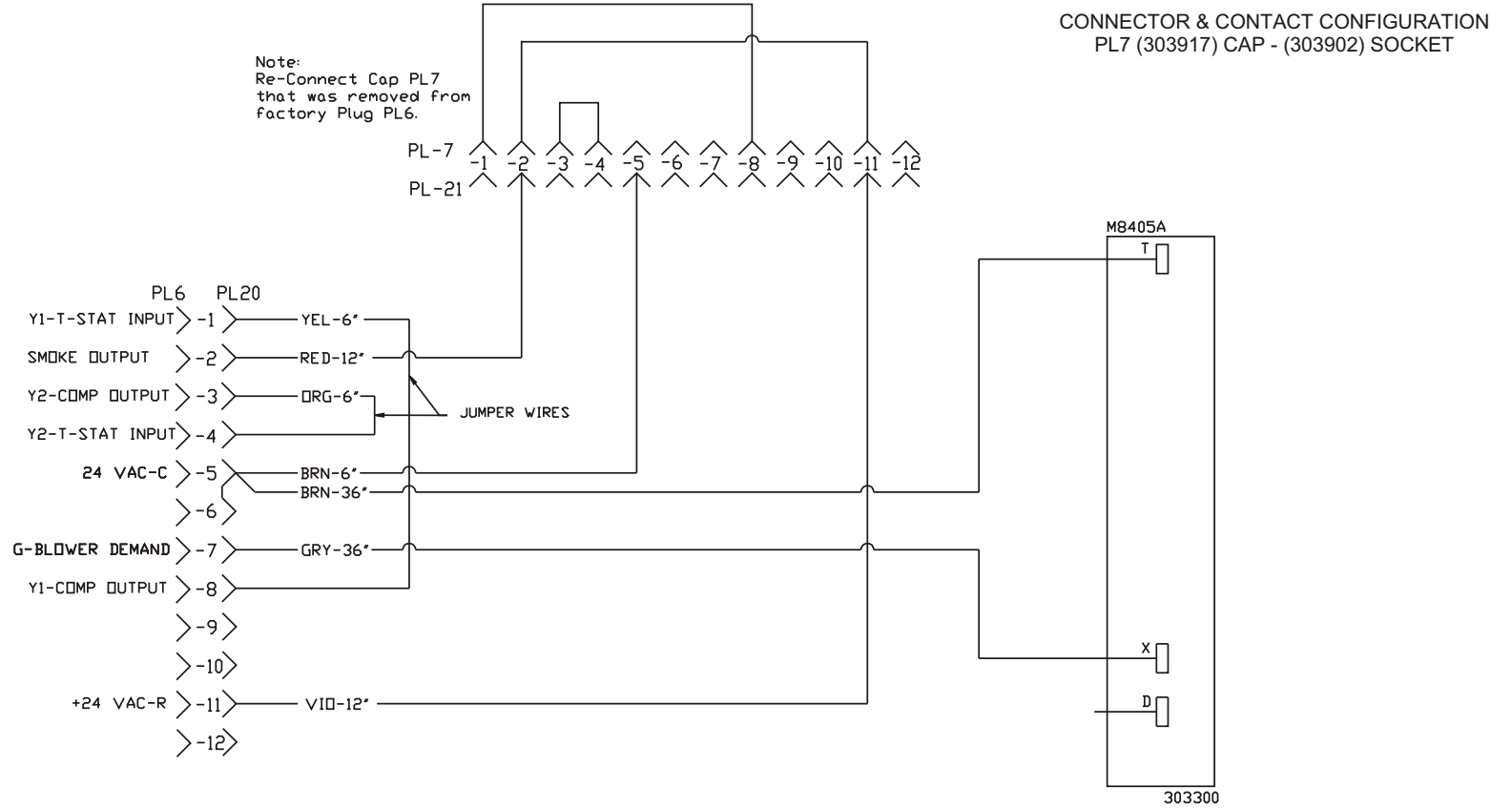

- Notes:
 1. Unit wiring shown as reference only. Check unit wiring for actual unit wiring.

**0-35% Motorized Outside Air
 (-)XR-AX02**



2405 McIver Lane
 Carrollton, Texas 75006
 Phone: (972) 247-7447
 Fax: (972) 243-0940

Date: March 19, 2009
Supersedes:
Drawn by: MGL
Unit #: 60-287-13D
Diagram#: 6028713DW
Approved by: