

# INSTALLATION INSTRUCTIONS

## MODELS (-)XRD-PDCM3 & (-)XRD-SDCM3

### VERTICAL AIRFLOW ECONOMIZERS

#### ▲WARNING

THIS ACCESSORY IS TO BE INSTALLED BY A QUALIFIED, LICENSED SERVICE PERSON. TO AVOID UNSATISFACTORY OPERATION OR DAMAGE TO THE PRODUCT AND POSSIBLE UNSAFE CONDITIONS, INCLUDING ELECTRICAL SHOCK, REFRIGERANT LEAKAGE AND FIRE, THE INSTALLATION INSTRUCTIONS PROVIDED WITH THIS ACCESSORY MUST BE STRICTLY FOLLOWED AND THE PARTS SUPPLIED USED WITHOUT SUBSTITUTION. DAMAGE TO THE PRODUCT RESULTING FROM NOT FOLLOWING THE INSTRUCTIONS OR USING UNAUTHORIZED PARTS MAY BE EXCLUDED FROM THE MANUFACTURER'S WARRANTY COVERAGE.

#### ▲WARNING

DISCONNECT ELECTRICAL POWER TO THE UNIT. FAILURE TO DO SO CAN CAUSE ELECTRICAL SHOCK RESULTING IN PERSONAL INJURY OR DEATH.

#### ▲WARNING

THE SMOKE DETECTOR MUST NOT BE RELIED UPON AS THE PRIMARY SMOKE DETECTION IN BUILDING SAFETY. THE ECONOMIZER SMOKE DETECTOR DE-ENERGIZES THE SUPPLY FAN AND CLOSSES THE OUTSIDE AIR DAMPER WHEN SMOKE IS DETECTED. REFER TO ENCLOSED SMOKE DETECTOR INSTRUCTIONS (SECTION 7) FOR TESTING OF ADEQUATE SMOKE SENSOR AIRFLOW UPON INSTALLATION OF (-)XRD-SDCM3 ECONOMIZER WITH SMOKE DETECTOR CAPABILITIES. SUFFICIENT DUCTED AIR VELOCITY MUST BE PRESENT ACROSS THE SMOKE DETECTOR SAMPLING TUBE TO ENSURE PROPER OPERATION. ADDING POWERED EXHAUST MAY BE REQUIRED IN BUILDINGS WITH EXCESSIVE ENVELOPE AIR LOSSES AND/OR RESTRICTIVE RETURN AIR CONDITIONS TO THE UNIT PREVENTING ADEQUATE RETURN AIR TO THE UNIT WHEN ECONOMIZER IS OPEN TO OUTSIDE AIR.

#### TOOLS REQUIRED FOR INSTALLATION:

$\frac{3}{8}$ " electric drill with  $\frac{5}{16}$ " socket

Small flat blade (0.125" wide) screwdriver

**TABLE 1**

PACKAGE CONTENTS		(-)XRD-PDCM3 economizer with controller, actuator, and outside enthalpy sensor attached	(-)XRD-SDCM3 economizer with smoke detector, controller, actuator, and outside enthalpy sensor attached
ITEM	DESCRIPTION	PART No.	PART No.
1	Discharge Air Sensor (Hardware Bag)	6036413B / 3112	6036413S / 3112
2	(2) Permanent Filters	6036413B / 8567 (11.875" X 23.875")	6036413S / 8568 (23.875" X 23.875")
3	Spotweld Assy - Bird Screen	6036413B / BSWA	6036413S / BSWA
4	Exhaust Air Rainhood Assy – Birdscreen Front Support	6036413B / EHB2	6036413S / EHB2
5	OA Rainhood Assy - Left Side	6036413B / EHSL	6036413S / EHSL
6	OA Rainhood Assy - Right Side	6036413B / EHSR	6036413S / EHSR
7	Exhaust Air Rainhood - Left Side	6036413B / EHS2L	6036413S / EHS2L
8	Exhaust Air Rainhood – Right Side	6036413B / EHS2R	6036413S / EHS2R
9	OA Filter Rail Assy	6036413B / EHT2	6036413S / EHT2
10	OA Rainhood Assy – Top	6036413B / EHT	6036413S / EHT
11	OA Rainhood - Front Filter Support	6036413B / EHB	6036413S / EHB
12	Hardware Bag	6036413B / HDW	6036413S / HDW
13	Smoke Detector w/ Harness	-----	6036413S / 3520
14	Sampling Tube	-----	6036413S / 3532
15	Sampling Tube Bracket	-----	6036413S / BRKT

**FIGURE 1**  
 (-)XRD-PDCM3 Shown - (-)XRD-SDCM3 Similar

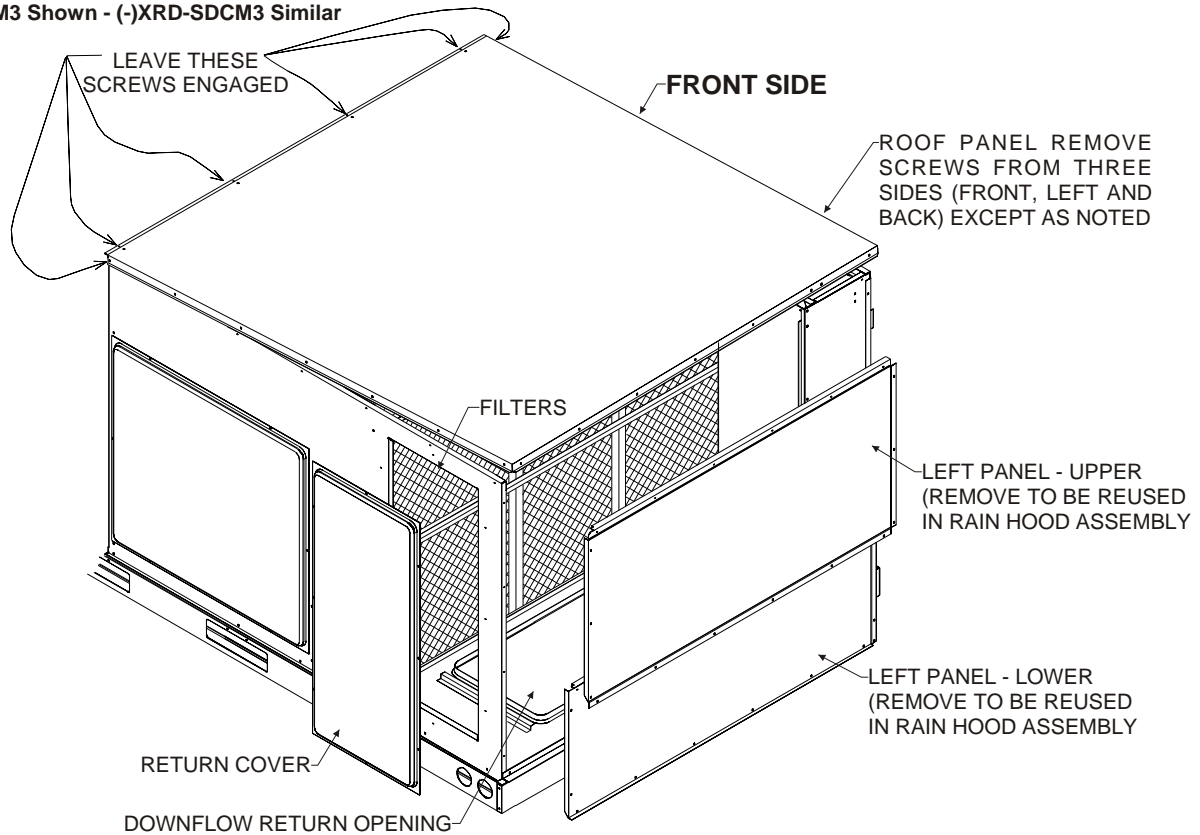

A1010-01

**STEP 1:**  
 Immediately upon receipt, all cartons and contents should be inspected for transit damage. Units with damaged cartons should be opened immediately. If damage is found, it should be noted on the delivery papers and a damage claim filed with the last carrier. Compare carton(s) contents to PACKAGE CONTENTS List (**TABLE 1**) above to note any missing items.

**STEP 2:**  
 Remove RETURN COVER, LEFT PANEL – UPPER and LOWER PANELS – LEFT BOTTOM SECTION from the unit and retain for reuse (**SEE FIGURE 1**). Retain screws.

**STEP 3:**  
 Remove screws from 3 sides of ROOF PANEL so that it can be raised during economizer insertion.

**NOTE 1:**  
 Remove shipping bracket, ② PERMANENT FILTERS, ⑤ OA RAINHOOD - LEFT SIDE, ⑥ OA RAINHOOD - RIGHT SIDE, ⑦ EXHAUST AIR RAINHOOD - LEFT SIDE and ⑧ EXHAUST AIR RAINHOOD – RIGHT SIDE from fresh air opening. (**SEE FIGURE 2**).

**STEP 4:**  
 Remove jumper plug and slide economizer into unit return air section (**SEE FIGURE 2**). After the economizer is installed, connect unit ECONOMIZER PLUG to economizer mating plug. **PDCM3** - Reinstall jumper plug PL7 to PL21 (located on economizer). **SDCM3** - Save jumper plug PL7 in this compartment for diagnostic purposes.

**FIGURE 2**

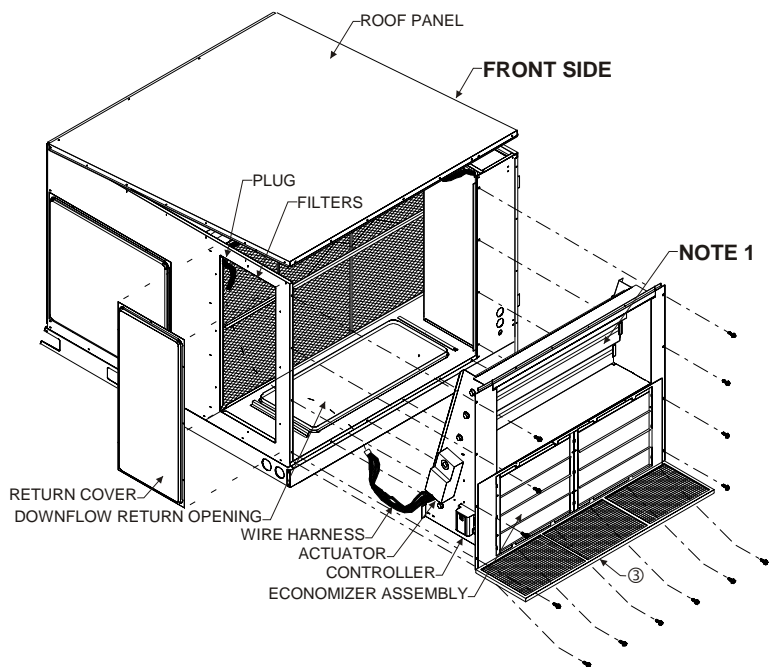

A1011-01

**STEP 5:**

Secure economizer and ③ SPOTWELD ASSY - BIRD SCREEN along bottom with six screws as shown (SEE FIGURE 2). See TABLE 1 for identification.

**STEP 6:**

Fasten ⑦ EXHAUST AIR RAINHOOD - LEFT SIDE and ⑧ EXHAUST AIR RAINHOOD - RIGHT SIDE to barometric relief opening (lower opening) on the economizer (SEE FIGURE 3). Fasten with six screws. See FIGURE 4 for identification of EXHAUST AIR RAINHOODS.

**STEP 7:**

Fasten ④ EXHAUST AIR RAINHOOD ASSY - BIRDSCREEN FRONT SUPPORT under edge of LEFT PANEL - LOWER using six screws. Do not install a screw in the rightmost hole in the panels at this time.

**STEP 8:**

Fasten LEFT PANEL - LOWER and ④ EXHAUST AIR RAINHOOD ASSY - BIRDSCREEN FRONT SUPPORT to the top of the ⑦ EXHAUST AIR RAINHOOD - LEFT SIDE and ⑧ EXHAUST AIR RAINHOOD - RIGHT SIDE which was previously installed on the unit (SEE STEP 7).

**STEP 9:**

Attach ⑨ OA FILTER RAIL ASSY to economizer center support, ⑦ EXHAUST AIR RAINHOOD - LEFT SIDE and ⑧ EXHAUST AIR RAINHOOD - RIGHT SIDE and LEFT PANEL - LOWER using screws provided.

**STEP 10:**

Position the ⑩ OA RAINHOOD ASSY - TOP under edge of ROOF PANEL. Do not install screws at this time.

**STEP 11:**

Fasten ⑤ OA RAINHOOD - LEFT SIDE and ⑥ OA RAINHOOD - RIGHT SIDE to unit using screws provided (2 each on (-)XRD-PDCM3, and on (-)XRD-SDCM3).

**STEP 12:**

Slide ② PERMANENT FILTERS between ⑤ OA RAINHOOD - LEFT SIDE and ⑥ OA RAINHOOD - RIGHT SIDE back into the ⑨ OA FILTER RAIL ASSY.

**STEP 13:**

Fasten ⑪ OA RAINHOOD - FRONT FILTER SUPPORT to LEFT PANEL - UPPER with six screws. The bottom lip should support the ② PERMANENT FILTERS. Do not install a screw in the rightmost hole in the panels at this time.

**STEP 14:**

Fasten LEFT PANEL - UPPER to ⑤ OA RAINHOOD - LEFT SIDE and ⑥ OA RAINHOOD - RIGHT SIDE and ⑪ OA RAINHOOD - FRONT FILTER SUPPORT using screws (12 on (-)XRD-PDCM3, and on (-)XRD-SDCM3).

**STEP 15:**

Re-secure ROOF PANEL using the washer head screws that were removed in STEP 3 from the ROOF PANEL.

**FIGURE 3**  
(-)XRD-PDCM3 Shown - (-)XRD-SDCM3 Similar  
(See Table 1 for identification of parts)

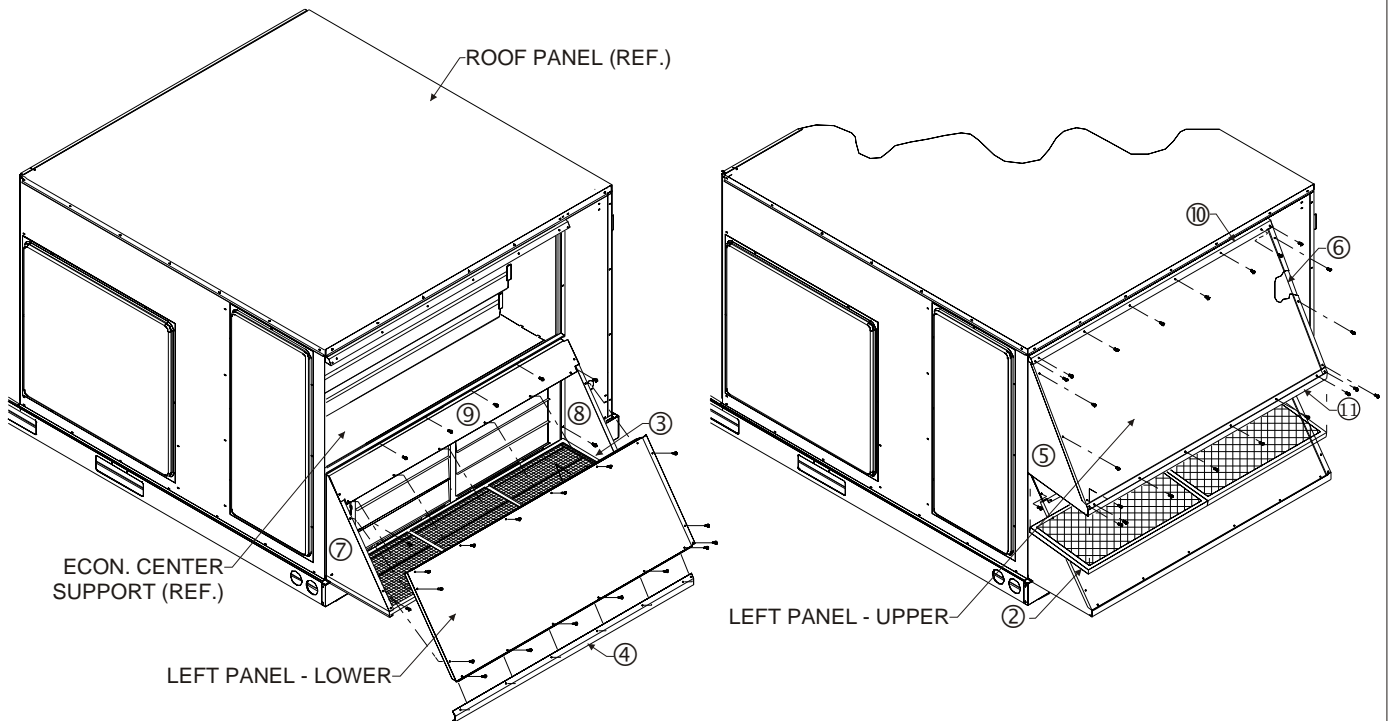

A1012-01

**FIGURE 4**

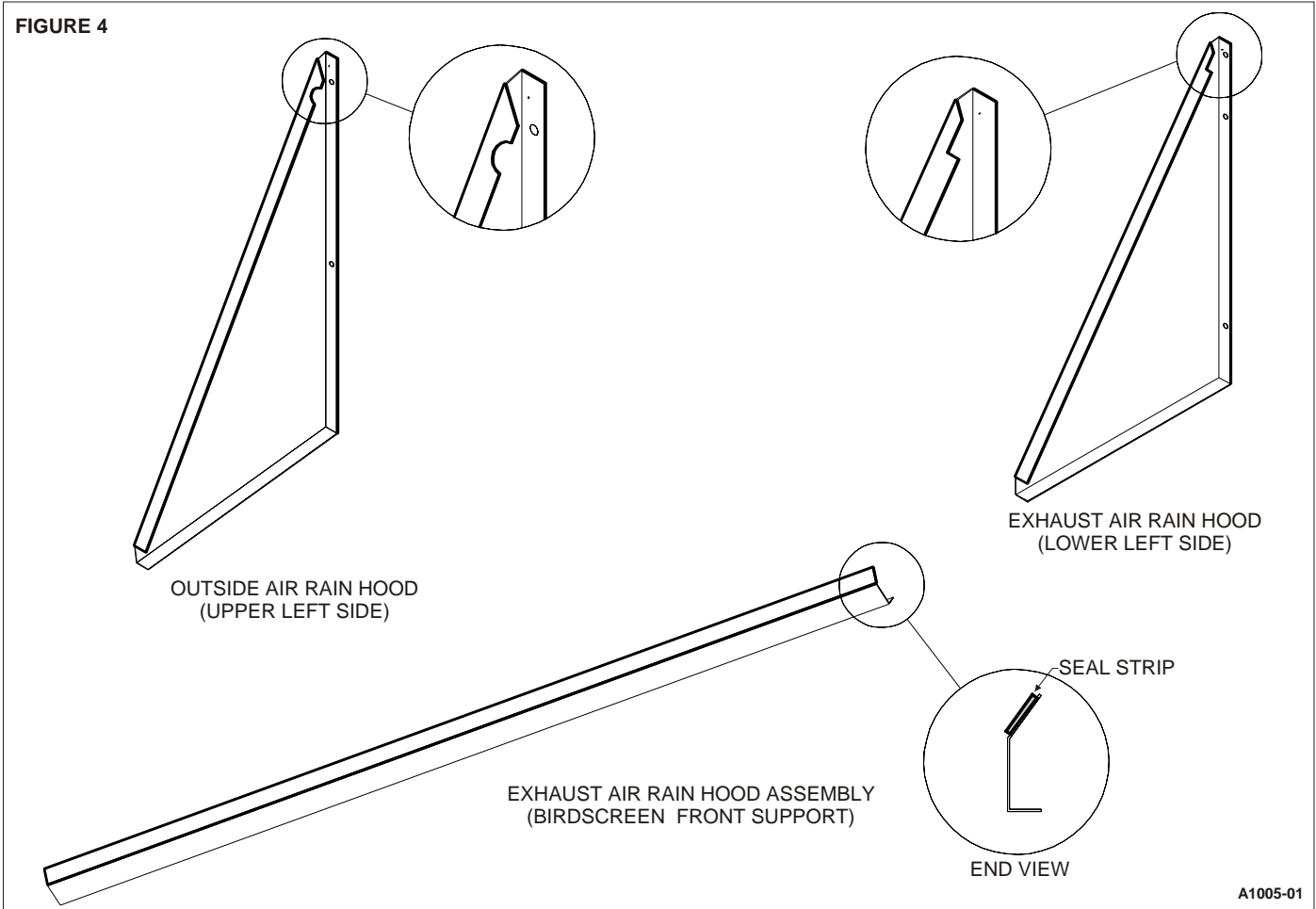

A1005-01

**STEP 16:**  
Remove the BLOWER MOTOR ACCESS PANEL (SEE FIGURE 5).

**STEP 17:**  
Connect the ① DISCHARGE AIR SENSOR to wires 51 and 52 located in the blower motor compartment.

**NOTE:**  
Mixed air sensor should be secured with the included wire tie to avoid entanglement with the blower and direct contact with any sheet metal surfaces.

**STEP 18:**  
Replace the BLOWER MOTOR ACCESS PANEL.

**STEP 19:**  
Upon start-up check the economizer sequence of operation using the steps provided in these instructions. After testing unit operation and setting outside air damper minimum position, replace RETURN COVER with remaining screws.

**FIGURE 5**

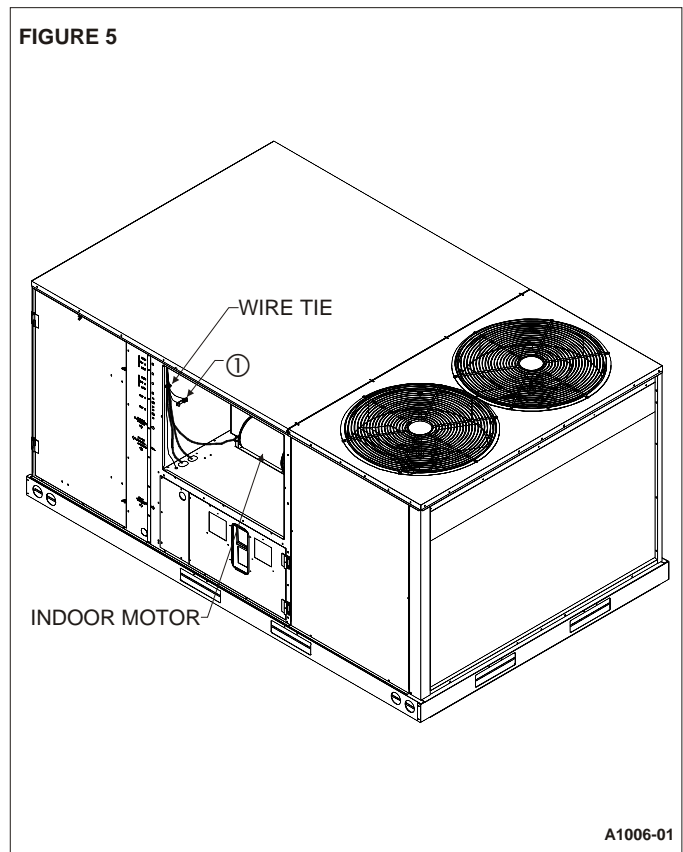

A1006-01

# DIRECT MOUNT ECONOMIZER SEQUENCE OF OPERATION

## GENERAL

This accessory economizer package is designed to save energy costs by using outdoor air for cooling and ventilation in place of mechanical cooling whenever possible. The economizer continuously monitors indoor and outdoor air conditions and compares them to a user-selected setpoint to determine if free cooling is available.

## ACCESSORIES

### (-)XRX-AV02 — Dual Enthalpy Upgrade Kit

For maximum energy savings, this upgrade kit will allow the economizer to compare the outdoor air enthalpy to the return air enthalpy, instead of a user-selected setpoint to determine if "free cooling" is available.

### (-)XRX-AR02 - Wall-Mounted Carbon Dioxide Sensor

For installations requiring Demand Control Ventilation (DCV) based upon indoor air levels of carbon dioxide (CO<sub>2</sub>). When the unit supply fan is running, the CO<sub>2</sub> sensor modulates the outside air damper to maintain a user-selected CO<sub>2</sub> level inside the occupied space. Energy savings are achieved by not bringing in excessive amounts of outdoor air when the indoor air conditions are suitable. Energy savings can be substantial on buildings with highly variable occupancy rates.

### Wall-Mounted Remote Potentiometer

For installations requiring remote adjustment of damper minimum position by the occupants, a remote potentiometer, such as the Honeywell S963B1128 can be used.

### (-)XRX-BFF02C, (-)XRX-BFF02D, (-)XRX-BFF02Y — Power Exhaust Kit

For installations requiring more space static pressure relief than can be obtained with the standard barometric relief damper included with the economizer, a power exhaust kit can be added.

## STARTUP

### Operational Note

For (-) XRD-SDCM3 economizer. After these startup adjustments have been completed, perform airflow measurement tests on the smoke detector to ensure adequate smoke detector sensing air. Refer to enclosed smoke detector instructions (section 7).

Attach connector from Economizer Controller to Rooftop Control Panel Connector and install discharge/mixed air temperature sensor per installation guide.

## ADJUSTMENTS

5 potentiometers with screwdriver adjustment slots, starting from top of controller

### 1. EXH Set — Adjustments for (optional) power exhaust

- A. The outside air damper position at which the power exhaust fan(s) will engage. The LED labeled EXH below the potentiometer adjustment will indicate when power exhaust is available. When the power exhaust call is made, the controller provides a 60 ±30 second delay before exhaust fan activation to allow the damper to reach the appropriate position.

- B. Range of adjustment is from 0-100% (2-10V); in most applications the power exhaust is set to engage at about 70% outside air.
2. Min Pos — Outside Air Damper minimum position
    - A. Adjust the minimum position potentiometer to allow the minimum amount of outdoor air, as required by local codes, to enter the building.
    - B. Range of adjustment is from 0-100% (2-10V); in most applications the minimum position is adjusted to allow 10% to 25% outside air to enter the system.
    - C. The Outside Air Damper Minimum Position potentiometer can be adjusted at any time.
    - D. Whenever the "G" (supply fan) signal is present, the damper will open to this minimum position unless:
      - a. It may modulate to a greater position if overridden by the CO<sub>2</sub> sensor (DCV).
      - b. It may not open if overridden by the discharge air temperature sensor (Freeze Protect Mode).
  3. DCV Max — Demand Control Ventilation (DCV) Maximum Setpoint
    - A. The DCV maximum position potentiometer allows the installer to limit the amount of outdoor air flow into the building when the DCV overrides the mixed air sensor.
    - B. Setting the DCV maximum position of the damper prevents the introduction of large amounts of hot or cold air into the space.
    - C. Note: If the DCV maximum position is set below the outside air damper minimum position, the minimum position overrides the DCV maximum position (negating the function of the DCV).

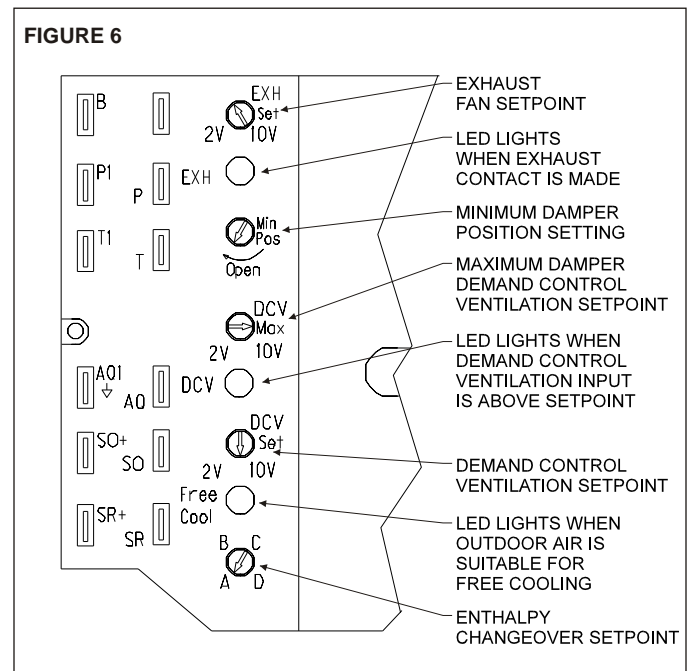

4. DCV Set — Demand Control Ventilation (DCV) Setpoint

- A. The DCV can be any sensor that provides a 2-10Vdc output. The DCV modulates the outdoor damper to provide ventilation based on occupancy. Typically, a carbon dioxide (CO<sub>2</sub>) sensor is used to indirectly monitor occupancy level.
- B. No cooling signal (e.g. Y1, Y2) is required for the DCV to override the outdoor air damper when ventilation requires outdoor air.
- C. The controller must receive a "G" (supply fan) signal to open the damper.
- D. Range of adjustment is from 2 Volts to 10 Volts.
- E. The DCV setpoint can be adjusted at any time.
- F. The controller compares the CO<sub>2</sub> sensor input to the setpoint setting to determine the damper minimum position.
  - a. If the actual CO<sub>2</sub> level is below the setpoint, then the damper minimum position is determined by the damper minimum position potentiometer setting.
  - b. If the actual CO<sub>2</sub> level rises above the setpoint, then the damper minimum position is overridden proportionally more open.
  - c. If the discharge air temperature drops below 48°F (Freeze Protect Mode), the DCV input will be overridden and the damper may not open.
- G. Compatible CO<sub>2</sub> sensors will have a 2-10Vdc output for a 0-1500 ppm CO<sub>2</sub> input.
- H. Ensure proper polarity of the sensor wires when connecting to the economizer controller. Incorrect polarity negates the sensor signal.

5. Economizer Setpoint

- A. Only the coolest, driest outside air is used for economizer operation when the potentiometer is on setting "D". For greatest energy savings, the potentiometer is on setting "A".
- B. Adjustment range is A, B, C, or D
  - a. Setting "A" = 73F db or 27 Btu/lbm @ 50% RH
  - b. Setting "B" = 70F db or 25 Btu/lbm @ 50% RH
  - c. Setting "C" = 67F db or 23 Btu/lbm @ 50% RH
  - d. Setting "D" = 63F db or 22 Btu/lbm @ 50% RH
- C. Economizer Setpoint potentiometer can be adjusted at any time.
- D. The controller compares the enthalpy sensor input with the economizer setpoint to determine if free cooling is available.
  - a. Single enthalpy strategy: If outdoor air enthalpy is lower than the setpoint, then free cooling is available. Note: The factory-installed 620-ohm resistor must be in place across terminals SR and SR+.
  - b. Dual enthalpy strategy: If outdoor air enthalpy is lower than return air enthalpy, then free cooling is available.

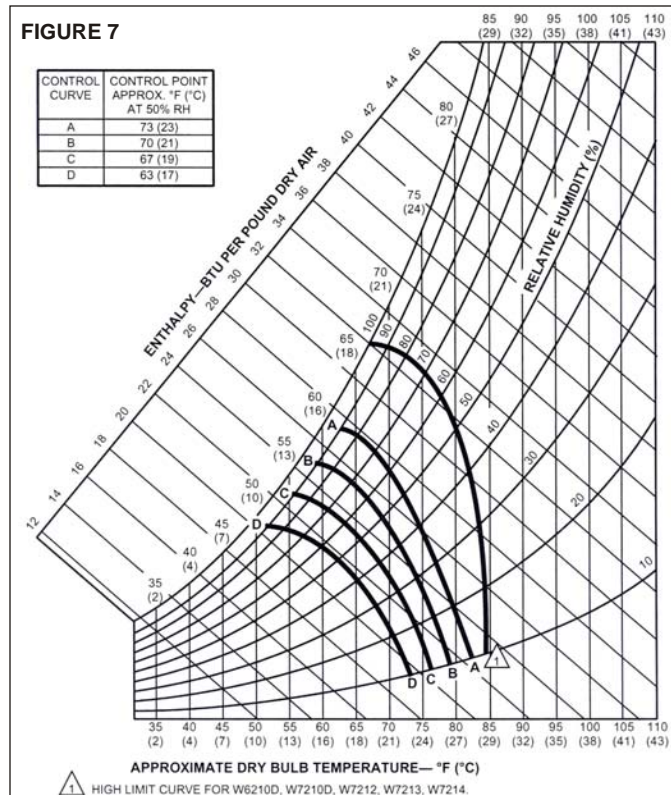

1. Note: If using dual enthalpy, the Economizer Setpoint must be at the "D" setting.
2. The factory-installed 620-ohm jumper must be removed to install the dual enthalpy upgrade kit.

**NORMAL OPERATION**

1. Fan Only (G)
  - A. Damper will go to minimum position (in 90 seconds or less) whenever the "G" (supply fan) signal is present.
  - B. When "G" signal is removed, the outside air damper closes against blade seals for tight shutoff of outside air.
  - C. If the discharge air temperature drops below 48°F, then the control will override the minimum position setting and will modulate the outside air damper closed.
2. Call for First Stage of Cooling (Y1)
  - A. Economizer Unavailable (warm outdoor air). Compressor 1 is commanded on without delay.
  - B. Economizer Available (free cooling). The controller tries to maintain a discharge air temperature of 53°F ± 5 by modulating the outside air damper position.
3. Call for Second Stage of Cooling (Y2)
  - A. Economizer Unavailable (warm outdoor air). Compressor 2 is commanded on without delay.
  - B. Economizer Available (free cooling). Compressor 1 is commanded on without delay. The controller tries to maintain a discharge air temperature of 53°F ± 5 by modulating the outside air damper position. Compressor 2 is not activated in the economizer mode.

4. Call for Heat
  - A. Standard Air Conditioner with electric or gas heat. (W1 & W2)
    - a. The Thermostat controls the stages of heating directly.
    - b. If the control detects that the supply fan is on (through its "G" input), then the control will open the damper to minimum position.
    - c. If the discharge air temperature drops below 48°F, then the control will override the minimum position setting and will modulate the outdoor damper closed.
  - B. Heat Pump Operation (B)
    - a. The "B" signal from the Thermostat allows operation of the compressors to provide heating without delay.
    - b. If the control detects that the supply fan is on (through its "G" input), then the control can open the damper to minimum position.
    - c. If the discharge air temperature drops below 48°F, then the control will override the minimum position setting and will modulate the outdoor damper closed.
5. Low Ambient Compressor Lockout – None present.

## TROUBLESHOOTING

1. Checkout requires a handheld multimeter, 9V battery, a 5.6k ohm .25 watt resistor, a 1.2k ohm .25 watt resistor, a jumper wire with .25" quick connect terminals, and the 620 ohm resistor that is factory-installed across terminals SR+ and SR. The terminal names below reference the economizer controller. Use the following flowcharts for to diagnose unit.
2.
  - a. Disconnect power to the unit.
  - b. Jumper P to P1 (factory installed jumper is normally present).
  - c. Remove outdoor air enthalpy sensor from terminals SO+ and SO and install the 1.2k ohm resistor.
  - d. Put 620 ohm resistor across terminals SR+ and SR (factory installed 620 ohm resistor is normally present and can be used).
  - e. Put 5.6k ohm resistor across T and T1.
3.
  - a. Turn (**EXH Set**) Exhaust fan Setpoint potentiometer fully CCW.
  - b. Turn (**Min Pos**) Minimum Outside Air Damper potentiometer fully CCW.
  - c. Turn (**DCV Max**) Demand Control Ventilation Maximum potentiometer fully CW.
  - d. Turn (**DCV Set**) Demand Control Ventilation Setpoint potentiometer fully CCW.
  - e. Turn enthalpy potentiometer to "D".

## BASIC ECONOMIZER OPERATION

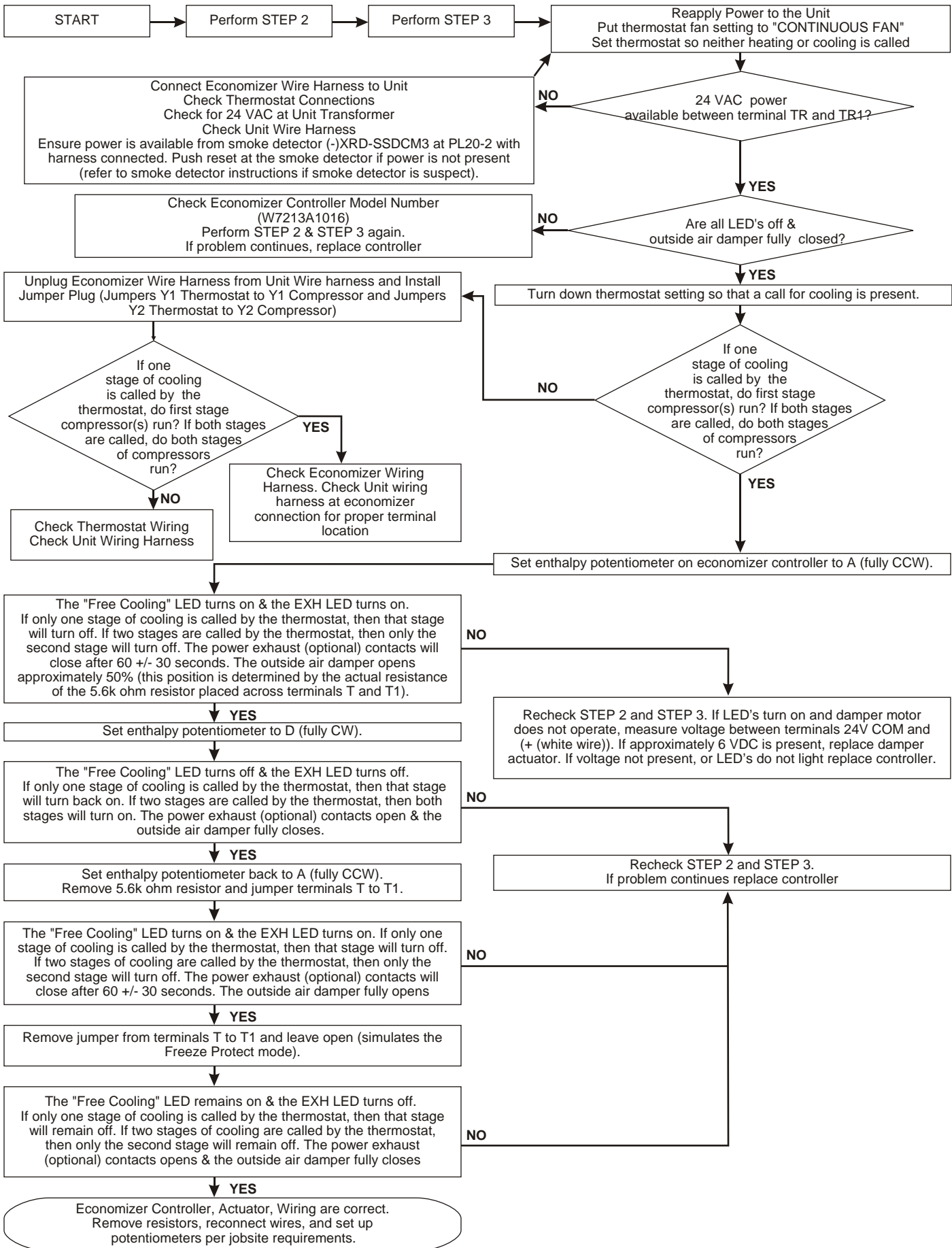



**HEAT PUMP OPERATION  
(Perform BASIC ECONOMIZER OPERATION check first)**

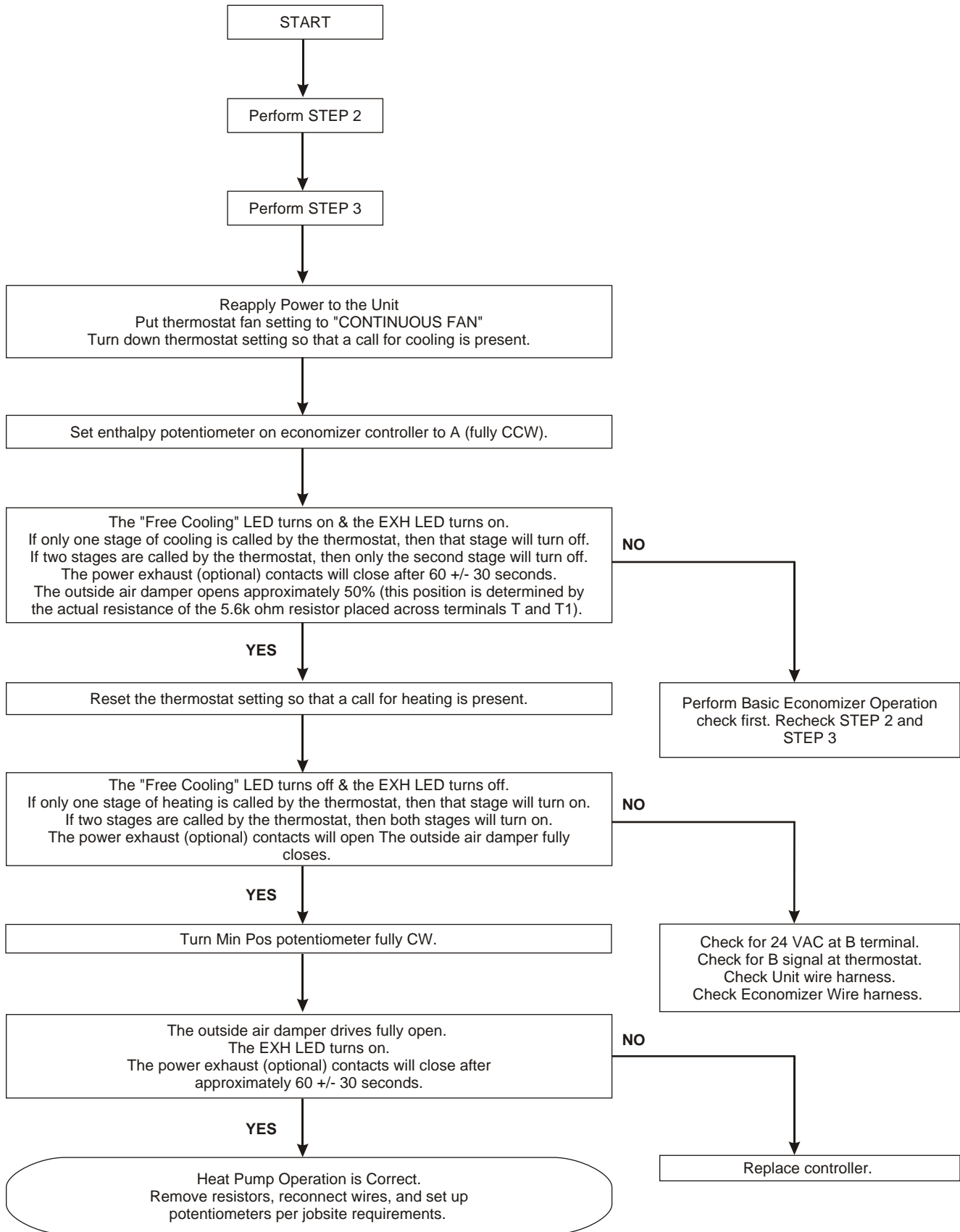

Use the following graph and the multimeter to verify proper operation of the mixed air / discharge air temperature sensor.

Measure the resistance (ohms) of the mixed air / discharge air temperature sensor with the multimeter. Look up the equivalent temperature on the graph. This should be the same as temperature the mixed air / discharge air sensor is detecting. If it is not, replace the mixed air / discharge air sensor.

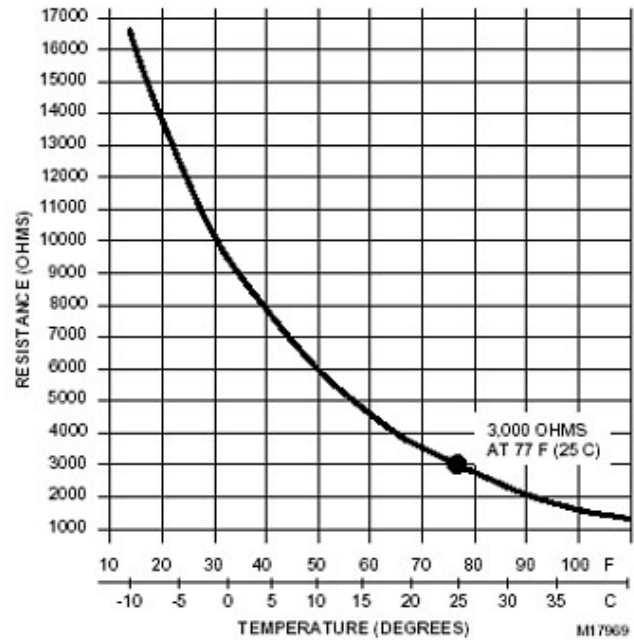

## NOTES

1. The mist eliminator (Permanent Outdoor Air Filter), is of aluminum mesh construction and should be cleaned by flushing regularly with warm soapy water. The replacement mist eliminator size is listed on the first page of these instructions.
2. When diagnosing the system, the best results are obtained by first putting the fan setting on the Thermostat to the "Continuous Fan" mode.
3. Operation of the optional power exhaust only depends upon the supply fan running and the damper position (it is possible to set the minimum position high enough to engage the power exhaust in the heating mode).
4. This economizer requires a two-stage thermostat.
5. Upon loss of power to the unit or economizer, the outside air damper will spring close shut in about 5 seconds.
6. Compressor Time Delays, Compressor Interstage Delays, Compressor Low Ambient Lockouts, etc. are not provided by the economizer controller.

HARNESS ENDS AT PL6

**COMPONENT CODE**

C7400A Fresh Air Sensor  
 9RT1H Mixed Air Sensor  
 J2 Power Exhaust Cap  
 MS7106K Damper Actuator 24v  
 PL6 Male A/C Unit Plug  
 PL7 Female A/C Unit Plug  
 PL20 Female Economizer Cap  
 PL21 Male Smoke Plug  
 W7213A Logic Module

**WIRE COLOR CODE**

BLK Black BLU Blue  
 BRN Brown GRN Green  
 GRY Gray ORG Orange  
 PNK Pink RED Red  
 TAN Tan VIO Violet  
 WHT White YEL Yellow

Revision	Change	Date

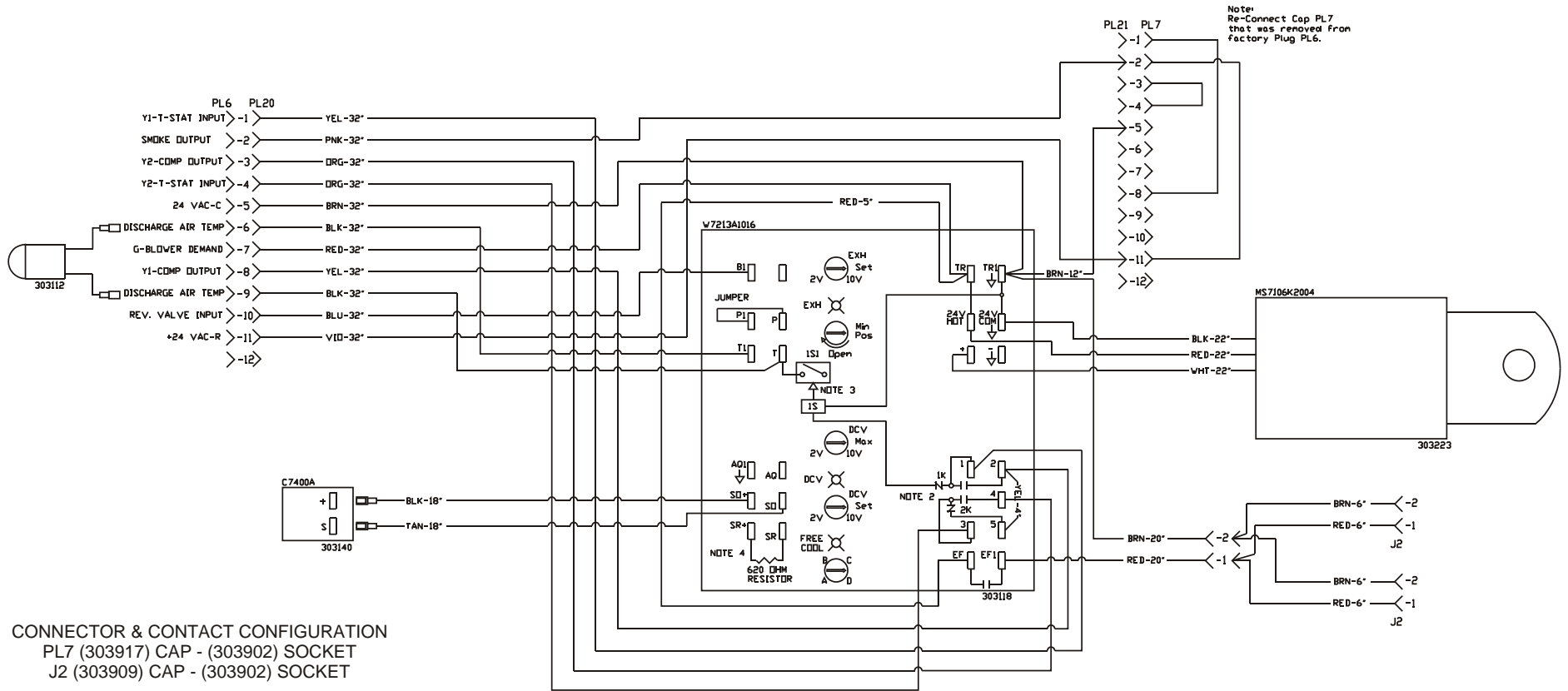

**Notes:**

- Unit wiring shown as reference only. Check unit wiring for actual unit wiring.
- Relays 1K and 2K actuate when the Outdoor Air Enthalpy is lower than the Return Air Enthalpy.
- 1S is an electronic switch which closes when powered by a 24 VAC input.
- Factory installed resistor should be removed only if C7400 Differential Enthalpy Sensor is added.
- Y2 must be energized for the compressor to operate.

**Modulating Gear Economizer  
 (-)XRD-PDCM3  
 RKNL/RLNL 072 - 150 Without Smoke Detector**



2405 McIver Lane  
 Carrollton, Texas 75006  
 Phone: (972) 247-7447  
 Fax: (972) 243-0940

Date: June 8, 2009
Supersedes: 03-19-09
Drawn by: MGL
Unit #: 60-364-13C
Diagram#: 6036413CW
Approved by:

HARNESS ENDS AT PL6

**COMPONENT CODE**

C7400A Fresh Air Sensor  
 9RT1H Mixed Air Sensor  
 J2 Power Exhaust Cap  
 MS7106K Damper Actuator 24v  
 PL6 Male A/C Unit Plug  
 PL20 Female Economizer Cap  
 PL21 Male Smoke Plug  
 PL22 Female Smoke Cap  
 W7213A Logic Module

**WIRE COLOR CODE**

BLK Black BLU Blue  
 BRN Brown GRN Green  
 GRY Gray ORG Orange  
 PNK Pink RED Red  
 TAN Tan VIO Violet  
 WHT White YEL Yellow

Revision	Change	Date

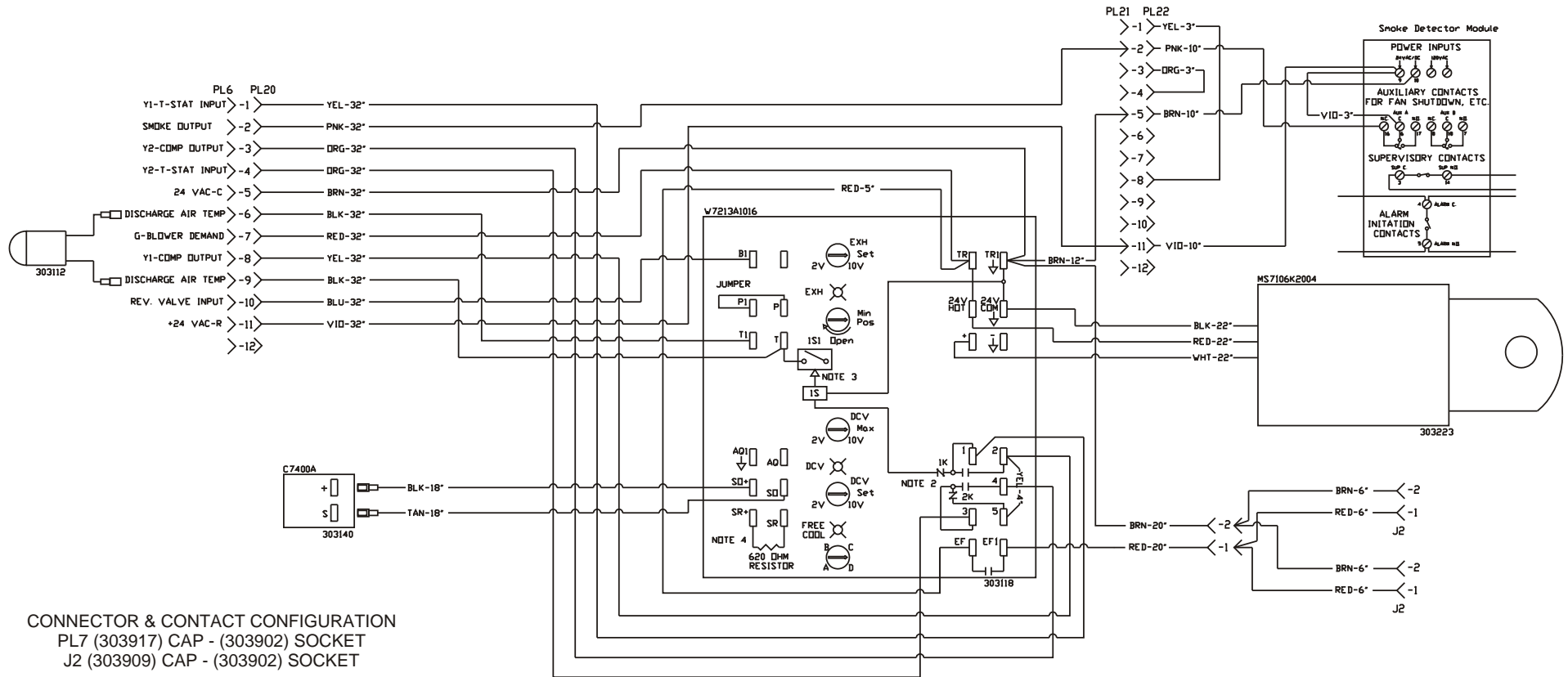

CONNECTOR & CONTACT CONFIGURATION  
 PL7 (303917) CAP - (303902) SOCKET  
 J2 (303909) CAP - (303902) SOCKET

**Notes:**

1. Unit wiring shown as reference only. Check unit wiring for actual unit wiring.
2. Relays 1K and 2K actuate when the Outdoor Air Enthalpy is lower than the Return Air Enthalpy.
3. 1S is an electronic switch which closes when powered by a 24 VAC input.
4. Factory installed resistor should be removed only if C7400 Differential Enthalpy Sensor is added.
5. Y2 must be energized for the compressor to operate.

**Modulating Gear Economizer  
 (-)XRD-SDCM3  
 RKNL/RLNL 072 - 150 With Smoke Detector**



2405 McIver Lane  
 Carrollton, Texas 75006  
 Phone: (972) 247-7447  
 Fax: (972) 243-0940

Date: June 8, 2009
Supersedes: 03-19-09
Drawn by: MGL
Unit #: 60-364-13S
Diagram#: 6036413SW
Approved by: