

INSTALLATION INSTRUCTIONS FOR FOSSIL FUEL KITS

▲WARNING

THESE INSTRUCTIONS ARE INTENDED AS AN AID TO QUALIFIED, LICENSED SERVICE PERSONNEL FOR PROPER INSTALLATION, ADJUSTMENT AND OPERATION OF THIS UNIT. READ THESE INSTRUCTIONS THOROUGHLY BEFORE ATTEMPTING INSTALLATION OR OPERATION. FAILURE TO FOLLOW THESE INSTRUCTIONS MAY RESULT IN IMPROPER INSTALLATION, ADJUSTMENT, SERVICE OR MAINTENANCE, WHICH CAN RESULT IN FIRE, ELECTRICAL SHOCK, CARBON MONOXIDE POISONING, EXPLOSION, PROPERTY DAMAGE, PERSONAL INJURY OR DEATH.

A NOTE ABOUT WIRING — All wiring is field wiring to be provided and installed by the technician in the field. Since it is impossible to know how much wire is needed (as every application is different), wiring is not provided with these kits.

RXPF-F01

A. INTENDED USE

This kit is intended to be used where the heat pump provides heat at a lower cost than natural or L.P. gas. The kit permits the heat pump to operate at temperatures usually from 30°F to 35°F (-1°C to +2°C) and above, where the heat pump is most efficient. For the colder periods, which in general is a minor part of the total heating season, the heating will be provided by a standard gas furnace that has approximately the same efficiency at all temperatures.

B. LOCATION AND WIRING

▲WARNING

DISCONNECT ALL POWER TO BOTH THE FURNACE AND THE HEAT PUMP OUTDOOR UNIT BEFORE PROCEEDING. FAILURE TO DO SO CAN CAUSE ELECTRICAL SHOCK RESULTING IN SEVERE PERSONAL INJURY OR DEATH.

Install the F01 Outdoor Thermostat enclosure in a location such that at least 10" of the thermostat bulb will be exposed to the outdoor temperature. Make low voltage wiring connections according to wiring diagram included with outdoor unit and the kit. Install the plenum switch in the supply air stream from the coil and wired per the diagram provided (Figure 1).

Calculate balance point (the temperature at which the heat pump capacity is equal to building loss), set outdoor thermostat at this point or slightly below.

Write the set point on Notice Label (92-22205-24) and stick the label on or near the indoor thermostat.

C. THERMOSTAT OPERATION

Instruct owner in use of heat pump and adjustment of outdoor thermostat. A lower setting of thermostat keeps the heat pump operating at colder outdoor temperatures.

1. **OPERATION WITH THE INDOOR THERMOSTAT SET TO NORMAL "HEAT" POSITION AND THE OUTDOOR THERMOSTAT TOGGLE SWITCH IN "NORMAL OPERATION" POSITION .**
 - A. On call for 1st stage heat: The furnace blower will run in cooling speed and heat pump will run when outdoor temperature is above the set point of the RXPF-F01. The furnace will run when the outdoor temperature is below the set point of the RXPF-F01. The indoor blower will not run during the furnace warm-up period.
 - B. On call for 2nd stage heat: No effect (other than auxiliary heat indicator is on). **NOTE: DO NOT CONNECT W2.**
 - C. During defrost, the furnace will be operated by the plenum switch (see Figure 1) whenever the supply air temperature drops below 95°F (35°C) and off when the air temperature increases above 110°F (43°C). Blower will continue to run in cooling speed.
2. **OPERATION WITH INDOOR THERMOSTAT SET TO NORMAL "HEAT" POSITION AND OUTDOOR THERMOSTAT TOGGLE SWITCH IN "HEAT PUMP ONLY" POSITION.**
 - A. On call for 1st stage heat: Blower and compressor start.
 - B. On call for 2nd stage heat: Blower continues to run and compressor continues to run. Auxiliary heat indicator is on. Furnace will not run. **NOTE: W2 of thermostat may not be connected!**
3. **"EMERGENCY HEAT" POSITION ON INDOOR WALL THERMOSTAT**
 - A. Outdoor unit is deenergized. Emergency heat indicator on thermostat is turned on.
 - B. On call for 1st stage heat: Furnace is started and is controlled by the integrated furnace control.

4. WITH TOGGLE SWITCH IN "HEAT PUMP ONLY" POSITION.

- A. The heat pump will run on a call for heat from the indoor wall thermostat above or below the outdoor thermostat set point.
- B. **NOTE:** With indoor wall thermostat switch in "Cool" position, the outdoor thermostat must be above the set point of the RXPF-F01. If not, the furnace will heat on call for cooling. If indoor cooling is required when the outdoor temperature is below the RXPF-F01 set point, this may be avoided by setting the outdoor thermostat in the "Heat" Pump Only" mode.

5. OPERATION OF THERMOSTAT FAN SWITCH

- A. Fan switch in "Auto" position: Blower runs whenever thermostat calls for cooling or heating.
- B. Fan switch in "On" position: Blower runs continuously except during furnace "warm-up" period.

NOTE: The operations as outlined above, assume use of the thermostats shown on the diagrams or equivalent.

NOTE: An RXPF-C01 or RXPF-E01 kit may be converted to an RXPF-F01 kit by re-wiring according to the RXPF-F01 wiring diagram.

NOTE: The RXPF-F01 kit is compatible with standing pilot blower controls; however, the blower will continue to run after switching between 1st and 2nd stage heat, Normal and Emergency heat or when switched by the outdoor thermostat.

RXPF-F02

NOTE: The relay (Part # 42-101208-01) which is included with this kit is for use only with systems that have a Rheem or Ruud (RGFD, RGGD, UGFD or UGGD) modulating gas furnace (see Section D). The relay is to be discarded for all other applications.

A. INTENDED USE

This kit is intended to be used where the heat pump provides heat at a lower cost than natural or L.P. gas. The kit permits the heat pump to operate at temperatures usually from 30°F to 35°F (-1°C to +2°C) and above, where the heat pump is most efficient. For the colder periods, which in general is a minor part of the total heating season, the heating will be provided by a standard gas furnace that has approximately the same efficiency at all temperatures. In addition to the features of the RXPF-F01, the RXPF-F02 can be used in TVA jurisdiction, when 2nd stage heat call from thermostat must be recognized or when installing with Rheem or Ruud 2 stage or modulating gas furnace.

B. LOCATION AND WIRING

WARNING

DISCONNECT ALL POWER TO BOTH THE FURNACE AND THE HEAT PUMP OUTDOOR UNIT BEFORE PROCEEDING. FAILURE TO DO SO CAN CAUSE ELECTRICAL SHOCK RESULTING IN SEVERE PERSONAL INJURY OR DEATH.

The F02 kit wiring board should be located in a dry and convenient location for wiring, usually near the furnace. Install the F02 Outdoor Thermostat enclosure in a location such that at least 10" of the thermostat bulb will be exposed to the outdoor temperature. Make low voltage wiring connections according to wiring diagram included with outdoor unit and the kit. Install the plenum switch in the supply air stream from the coil and wired per the diagram provided (Figure 1).

Calculate balance point (the temperature at which the heat pump capacity is equal to building loss), set outdoor thermostat at this point or slightly below.

Write the set point on Notice Label (92-22205-24) and stick the label on or near the indoor thermostat.

C. THERMOSTAT OPERATION WITH TYPICAL SINGLE OR 2 STAGE GAS FURNACE

1. OPERATION WITH INDOOR THERMOSTAT SYSTEM SWITCH IN NORMAL "HEAT" POSITION AND OUTDOOR THERMOSTAT TOGGLE SWITCH IN "NORMAL OPERATION" POSITION

- A. On call for 1st stage heat: Furnace blower will run in cooling speed and heat pump will run when outdoor temperature is above the set point of the RXPF-F02. The furnace will run when the outdoor temperature is below the set point of the RXPF-F01. The indoor blower will not run during the furnace warm-up period.
- B. On call for 2nd stage heat: The furnace will run. Outdoor unit is de-energized. For 2 stage gas furnaces, 2nd stage heat is engaged only. The indoor blower will not run during the furnace warm-up period. Auxiliary heat indicator is on.
- C. During defrost the furnace will be operated by the plenum switch (see Figure 1) whenever the supply air temperature drops below 95°F (35°C) and off when the supply air temperature increases above 110°F (43°C). Blower will continue to run in cooling speed.

2. "EMERGENCY HEAT" POSITION ON INDOOR WALL THERMOSTAT (OPTIONAL)

- A. Outdoor unit is deenergized. Emergency heat indicator on thermostat is turned on.
- B. On call for 1st stage heat: Furnace is started and is controlled by integrated furnace control.

3. WITH TOGGLE SWITCH IN "HEAT PUMP ONLY" POSITION.

- A. The heat pump will run on a call for heat or cool from the indoor wall thermostat above or below the outdoor thermostat set point.
- B. **NOTE:** With indoor wall thermostat switch in "Cool" position, the outdoor temperature must be above the set point of the RXPF-F01. If not, the furnace will heat on call for cooling. If indoor cooling is required when the outdoor temperature is below the RXPF-F01 set point, this may be avoided by setting the outdoor thermostat in the "Heat Pump Only" mode.

4. OPERATION OF THERMOSTAT FAN SWITCH

- A. Fan switch in "Auto" position: Blower runs whenever thermostat call for cooling or heating.
- B. Fan switch in "On" position: Blower runs continuously except during furnace "warm-up" period.

NOTE: The operations as outlined above, assume use of the thermostat shown on the diagrams or equivalent.

NOTE: The RXPF-F02 kit is compatible with standing pilot blower controls; however, the blower will continue to run after switching between 1st and 2nd stage heat, Normal and Emergency heat or when switched by the outdoor thermostat.

D. THERMOSTAT OPERATION WITH TYPICAL RHEEM OR RUUD MODULATING GAS FURNACE.

NOTE: MODULATING CONTROL MUST BE RHEEM PART NUMBER 62-24174-01 REV. -03 OR NEWER.

NOTE: BOTH DIP SWITCHES OF SW-2 OF THE MODULATING CONTROL (IFC) MUST BE IN THE "ON" POSITION (TIMED TWO-STAGE HEAT OPERATION).

NOTE: THERMOSTAT MUST HAVE A "W2" CONNECTION FOR SECOND-STAGE HEAT WHEN CONFIGURED FOR A MODULATING FURNACE.

REFER TO THE WIRING DIAGRAM(S) IN THE FOSSIL FUEL KIT INSTALLATION INSTRUCTIONS (RHEEM FORM X11-1117 REV 6 OR NEWER, OR RUUD FORM X22-1117 REV 6 OR NEWER).

5.1 First-Stage Heat Call (Thermostat "Y"+"B")

- (1) The system receives a demand for heat from the indoor thermostat ("Y" and "B")
 - "B" is energized when the indoor thermostat is set to "HEAT"
 - "Y" is energized when the indoor thermostat calls for heat.
- (2) "B" is routed directly to the outdoor unit for the heat pump heating control system. (Usually a reversing valve).
- (3) "Y" is routed to the outdoor thermostat:

Condition 1: When the outdoor air temperature is *above* the setpoint of the outdoor thermostat *and* the indoor thermostat only senses a need for first-stage heat, the operation is normal heat pump. Both the cooling contactor on the condenser and cooling speed fan on the control board (IFC) (via "Y") are energized at this point.

Condition 2: When the outdoor air temperature is *below* the setpoint of the outdoor thermostat *and* the indoor thermostat only senses a need for first-stage heat, heating control is switched directly to the modulating gas furnace by energizing "W" on the modulating control (IFC) alone. This will give 40% (low fire) gas heat until either a second-stage heat call is present or the thermostat heat call is satisfied. At this point, the thermostat has energized both "Y" and "B", but the fossil fuel kit changes the "Y" signal into a "W" call to the modulating control. The cooling contactor is de-energized during this mode and the compressor and condenser fan are turned off.

The reversing valve (via "B") is energized throughout Condition 1 or 2, but is ignored and has no consequence in Condition 2 since the compressor and condensing fan are not running in Condition 2.

5.2 Second-Stage Heat Call (Thermostat "W2" + "Y" + "B")

- (1) When the system thermostat determines that the indoor air temperature is significantly below the setpoint of the thermostat, it will call for second-stage heat. Second-Stage heat with a modulating furnace as installed and wired per this document will be gas heat starting at 65% of full fire.

"W2", "Y" and "B" are simultaneously energized by the thermostat.

"W2" is routed to the modulating furnace control to energize both "W" and "V/W2" on the modulating control board (IFC) (through the relay provided with the RXPF-F02). This turns on gas heat at 65% for seven minutes followed by 100% gas heat until the Second-Stage heat call is satisfied.

"Y" is turned off by the FFK IWB (Fossil Fuel Kit Interface Wiring Board) so that the cooling contactor is NOT energized. **NOTE:** At this point, "Y" from the thermostat to the FFK IWB will be energized, however, neither "Y" between the FFK IWB and the cooling contactor nor "Y" between the FFK IWB and the modulating control (IFC) will be energized.

The reversing valve (via "B") is energized during the Second-Stage heat call, but is ignored and has no consequence on the system since the compressor and condensing fan will not be running during Second-Stage Heat.

5.3 Defrost (Thermostat "Y" + "B") (Defrost Control "W2" or "D")

- (1) The system receives a backup heat demand from the outdoor unit defrost control (Defrost Control "W2" or "D")
- (2) When the defrost control determines there is a need to defrost the coil, the heating call is re-routed by the defrost control back to the FFK IWB. The Defrost control also forces the reversing valve to run the AC system in cooling.
- (3) The Defrost mode heat call from the outdoor unit is routed to the FFK IWB, through the Plenum Sensor and finally to "W" and "V/W2" on the modulating control (IFC). The modulating furnace begins heating at 65% of full fire for seven minutes followed by 100% until the heat/defrost call is satisfied.
- (4) A plenum switch is provided to control heat in the defrost mode. This switch prevents the evaporator coil from overheating when gas heat is running in the defrost mode.
- (5) The "Y" (Cooling) circuit remains energized on the modulating control (IFC). This means that the furnace is running at either 65% or 100% of full fire heat with cooling speed blower.
- (6) The compressor and condensing fan of the cooling system will be running in the cooling direction during the Defrost mode to transfer heat to the condensing coil to melt away any frost or ice build-up on the condenser.

The reversing valve (via B) is de-energized during the defrost cycle. During defrost mode, "B" from the thermostat through the FFK IWB and out to the defrost control will be energized, but the circuit from the defrost control to the reversing valve will NOT be energized as the defrost control forces the reversing valve into cooling.

5.4 Call for Emergency Heat (Thermostat "E")

- (1) In the Emergency Heat mode, the indoor thermostat routes all heat demands (first- and second-stage) to the modulating furnace so that, with an Emergency heat call from the thermostat, gas heat will turn on at 65% of full fire for seven minutes followed by 100% until the Emergency Heat call is satisfied.

The reversing valve (via "B") is energized during the Emergency Heat call, but is ignored and has no consequence on the system since the compressor and condensing fan will not be running during Emergency Heat.

5.5 Call for Cooling (Thermostat "O", "Y" & "G" or "Y" & "G")

- (1) In the cooling mode, the system receives a demand for cooling from the indoor thermostat.

When the thermostat recognizes a need for cooling, "Y" is energized by the thermostat and the FFK IWB uses this signal to energize "Y" to the modulating control (IFC) and to the cooling contactor.

In cooling, "B" is de-energized and "O" is energized. This sets the reversing valve for the cooling mode.

- (2) "O" is routed to the outdoor unit for the heat pump cooling control system (usually the "Low-Ambient" relay or alternate reversing valve control system.)

5.6 Call for Continuous Fan (Thermostat "G")

- (1) The system receives a demand from the indoor thermostat "G".
- (2) The fan call is routed directly to the "G" terminal on the modulating control (IFC).

OPTIONAL ACCESSORY (May Be Used With F01 or F02 Kit)

Heat Pump Monitor, Model RXPM-B01

If for any reason the heat pump fails to produce useful heat, the monitor will shut off the heat pump and turn on an indicator in the thermostat. This indicates to the user that the heat pump is not functioning properly. It does this by sensing the liquid line pressure. A 15 minute time delay in the monitor prevents false indications at start and after defrost.

Install per instructions packed with the monitor and connect wiring per instructions indicated.

NOTE: With the RXP-F02 kit, a call for 2nd stage heat will turn on the furnace if the heat pump is locked-out due to the monitor. The RXP-F01 kit does not have this capability.

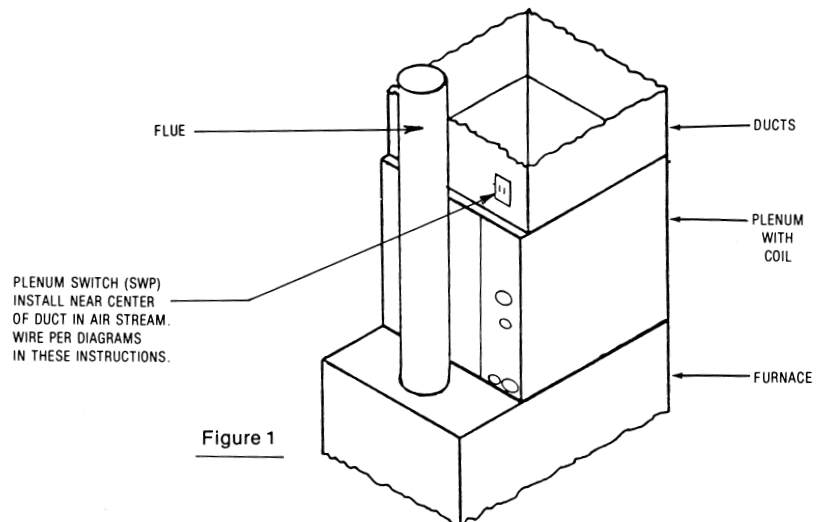

Figure 1