

LOUVERED CABINET GRILL RXHK-

▲ WARNING

TO ENSURE PROPER INSTALLATION AND OPERATION OF THIS PRODUCT, COMPLETELY READ ALL INSTRUCTIONS PRIOR TO ATTEMPTING TO ASSEMBLE, INSTALL, OPERATE, MAINTAIN OR REPAIR THIS PRODUCT. UPON UNPACKING OF LOUVERED CABINET GRILL, INSPECT ALL PARTS FOR DAMAGE PRIOR TO INSTALLATION AND START UP.

LOUVERED CABINET GRILL RXHK-

The RXHK Louvered Cabinet Grill is used in applications where the air handler front return opening needs to be covered with a louvered grill. Table 1 illustrates which accessory model goes with each model of air handler and the list of parts that will be required for proper installation:

INSTALLATION INSTRUCTIONS:

NOTE: Skip steps 1-5 if un it comes with factory installed nut zerts.

1. Drill 3/8" hole (1 on each side) into the hexagonal holes located on the front of the air handler. Reference Figure 2.
2. Install the jack nut by inserting the nut into the hexagonal hole drilled in step 1.

3. Place the jack nut wrench in front of the jack nut. Reference Figure 2.
4. Thread the machine screw provided and tighten until the jack nut is securely fastened into the air handler. Reference Figure 3.
5. Repeat steps 2 and 3 to install the jack nut on the opposite side.

TABLE 1

	Indoor Unit
RXHK-C01	RHAL-FR18
	RHAL-FR24
	RHBL-FR24
RXHK-C02	RHAL-FR30
	RHAL-FR36
	RHBL-FR36

Parts List

Qty.	Description
1	Decorative Grill
2	#10-24 Thumb Screws
2	#10-24 Jack Nut
1	Jack Nut Wrench
1	#10-24 Machine Screw
2	Thumb Screw Retainer

**FIGURE 1
UNIT ASSEMBLY INSTRUCTIONS**

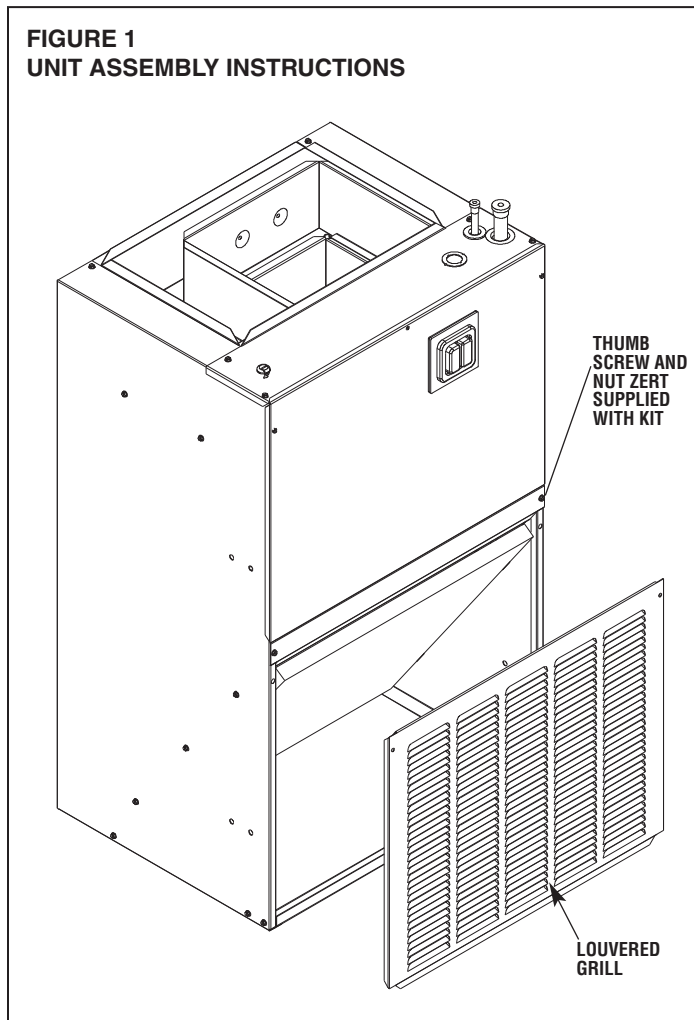
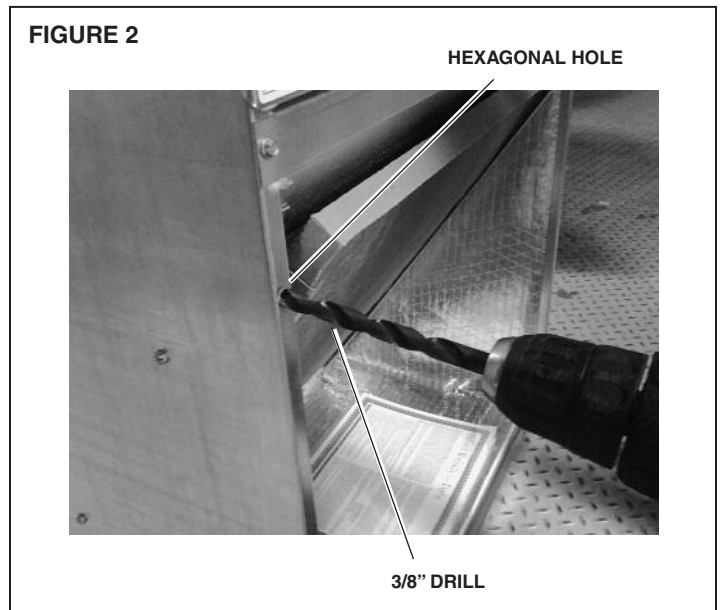
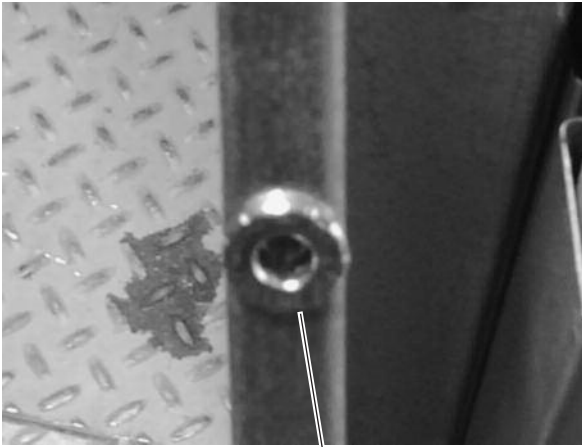

FIGURE 2



6. Insert the provided thumb screws into the mounting holes on the decorative grill and thread the #10 retaining washer on the insulation side of the decorative grill. This will ensure that the thumb screws will not be lost during the routine maintenance such as filter changes. Reference Figure 4.
7. Install decorative grill and tighten the thumb screws into the jack nuts which were installed in steps 1-5 if required.

FIGURE 4



JACK NUT FIRMLY IN PLACE

FIGURE 3

5/16" BOX END WRENCH

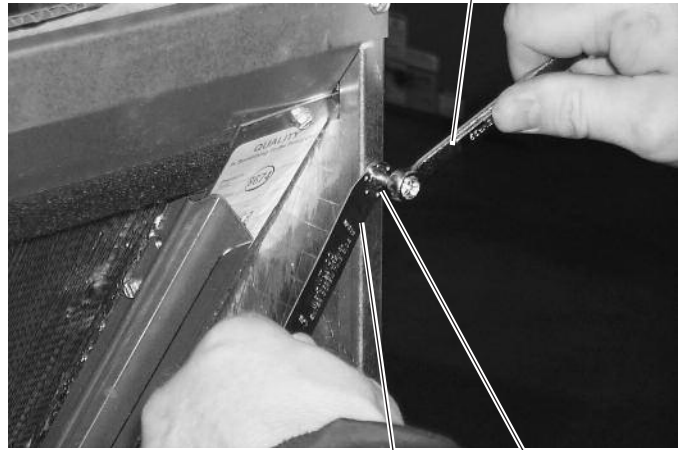

NUT ZERT WRENCH

#10-24 MACHINE SCREW

FIGURE 5

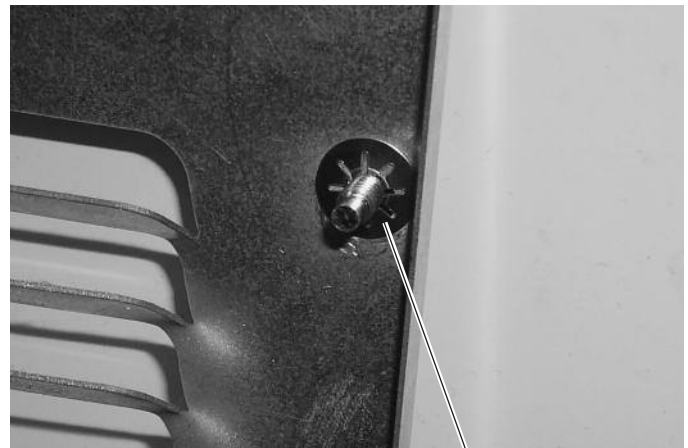

THREAD RETAINING WASHER ONTO THUMB SCREWS