

# FLOAT SAFETY SWITCH RXHK-A01



**RECOGNIZE THIS SYMBOL AS AN INDICATION OF IMPORTANT SAFETY INFORMATION!**

## ▲ WARNING

THESE INSTRUCTIONS ARE INTENDED AS AN AID TO QUALIFIED SERVICE PERSONNEL FOR PROPER INSTALLATION, ADJUSTMENT AND OPERATION OF THIS UNIT. READ THESE INSTRUCTIONS THOROUGHLY BEFORE ATTEMPTING INSTALLATION OR OPERATION. FAILURE TO FOLLOW THESE INSTRUCTIONS MAY RESULT IN IMPROPER INSTALLATION, ADJUSTMENT, SERVICE OR MAINTENANCE, POSSIBLY RESULTING IN FIRE, ELECTRICAL SHOCK, CARBON MONOXIDE POISONING, EXPLOSION, PROPERTY DAMAGE, PERSONAL INJURY OR DEATH.

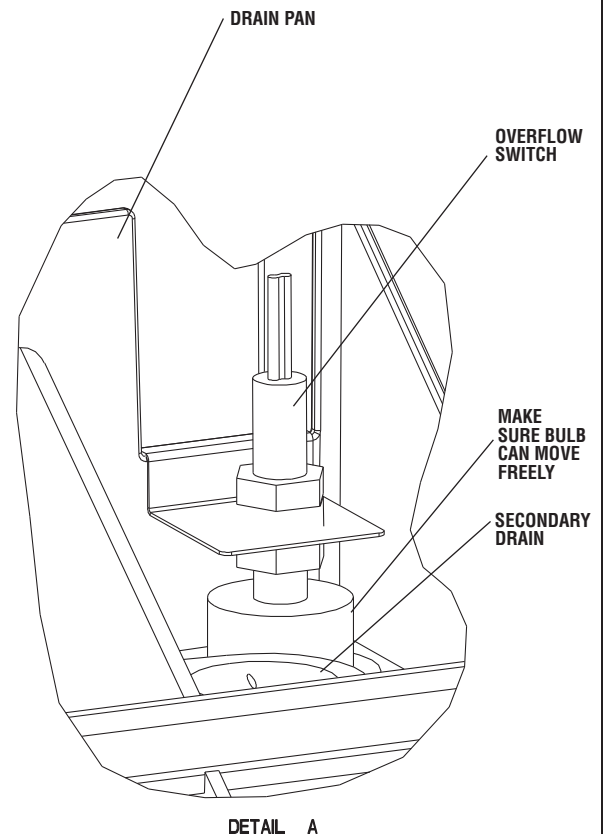
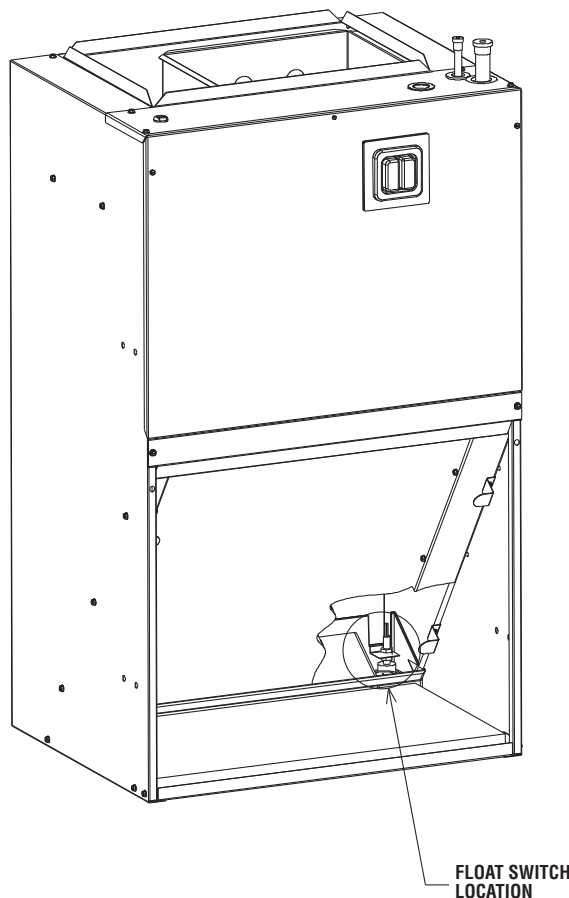
### FLOAT SAFETY SWITCH RXHK-A01

The float safety switch is design to shut off power off to the outdoor unit in the event of condensate drain blockage. This will in turn help to prevent any water or structural damage to the surrounding areas of the air handler.

Parts List	
Qty.	Description
1	Float Safety Switch
1	Zip Tie
2	Wire Nut
1	Notification Sticker

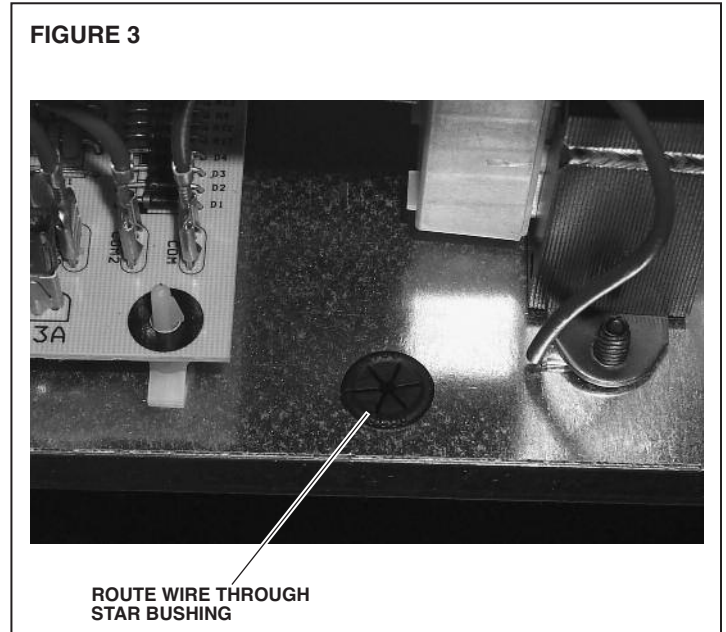
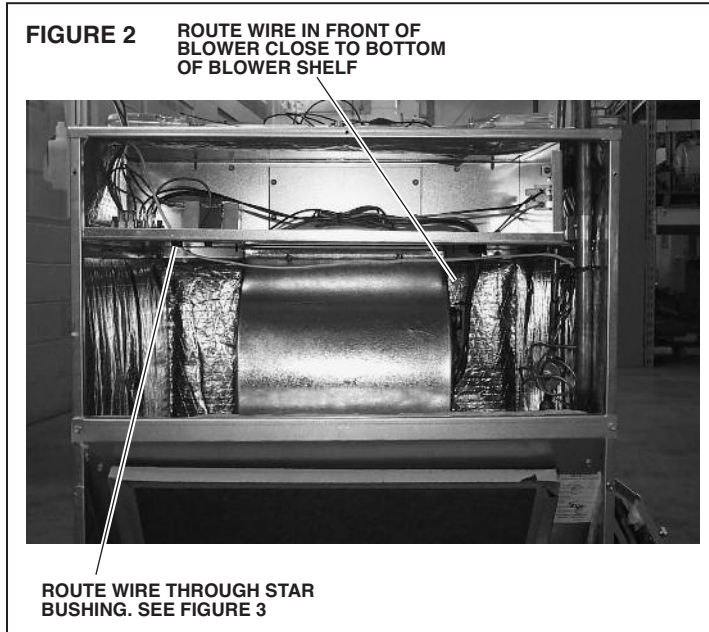
### INSTALLATION INSTRUCTIONS:

FIGURE 1



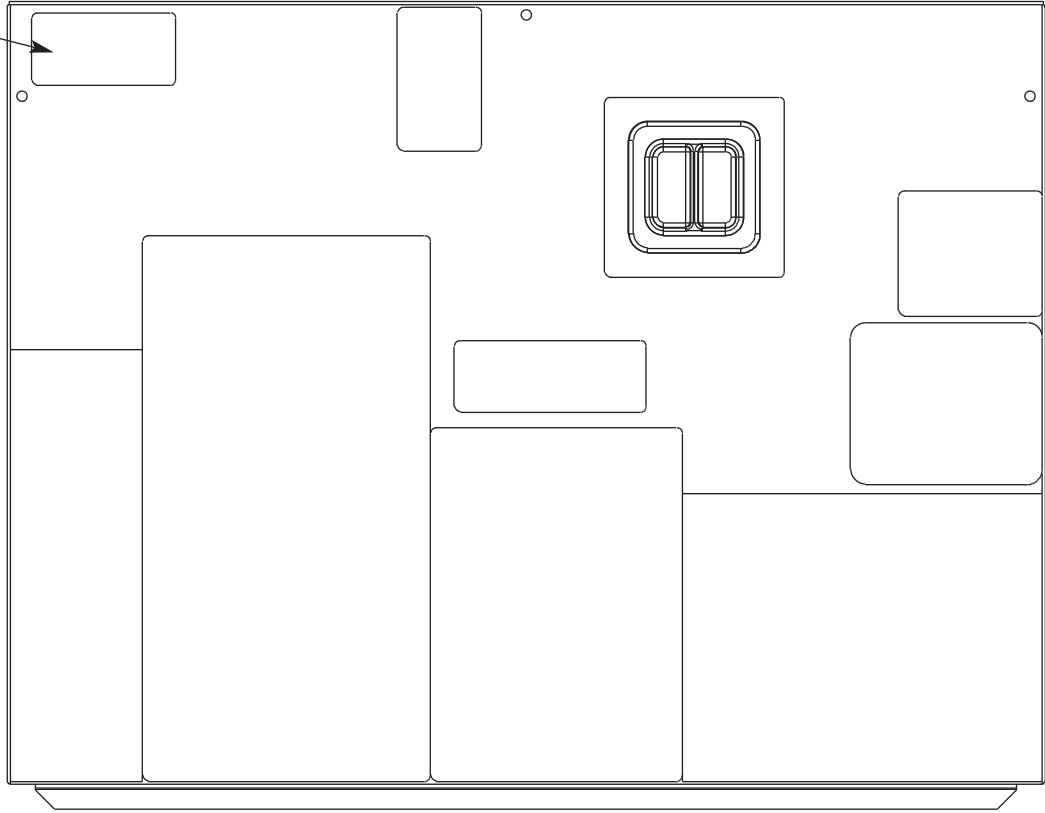
1. Disconnect all power from to the indoor and outdoor unit.
2. Remove the blower door panel from the air handler and remove the control box cover from the outdoor unit.
3. Insert the float safety switch into the designated area located on the drain pan. Make sure that the bulb can travel freely in the vertical direction and is leveled properly. Reference figure 1 for more detail.
4. Route the wiring harness of the float safety switch along the side of the suction tube of the front return air handler. Zip tie the wiring harness near the top of the suction tube and feed the remaining wire through the star bushing provided on the blower shelf of the air handler. Reference Figures 2 & 3.

5. Verify which indoor and outdoor unit that you have and connect the electrical wiring as shown in Figure 5.
6. Reinstall indoor blower door panel and outdoor control box cover.
7. Install notification sticker. Reference Figure 4.
8. Reconnect power.

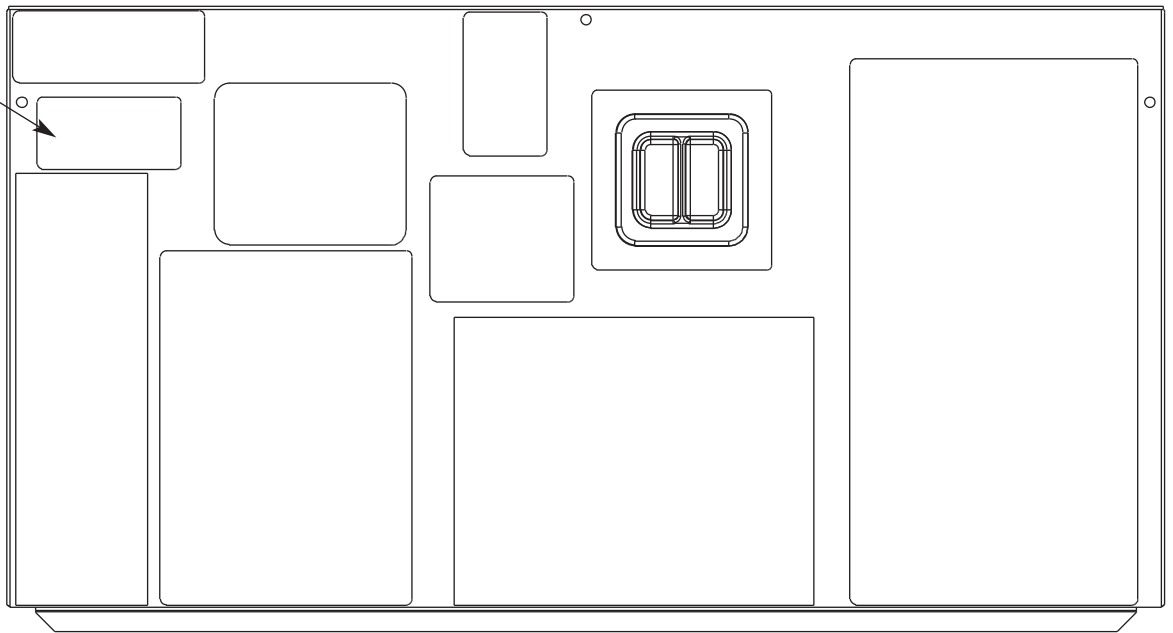


**FIGURE 4**  
**NOTIFICATION STICKER LOCATION**

FLOAT SWITCH LABEL  
(SMALL CABINET)



FLOAT SWITCH LABEL (LARGE CABINET)



**FIGURE 5**  
**FLOAT SWITCH WIRING DIAGRAM**

