



The new degree of comfort.™

Rheem *Commercial Classic*® Series Package Dual Fuel Unit



RQPW- 14-SEER Series
Nominal Sizes 2-4 Tons [7.0-14.0 kW]



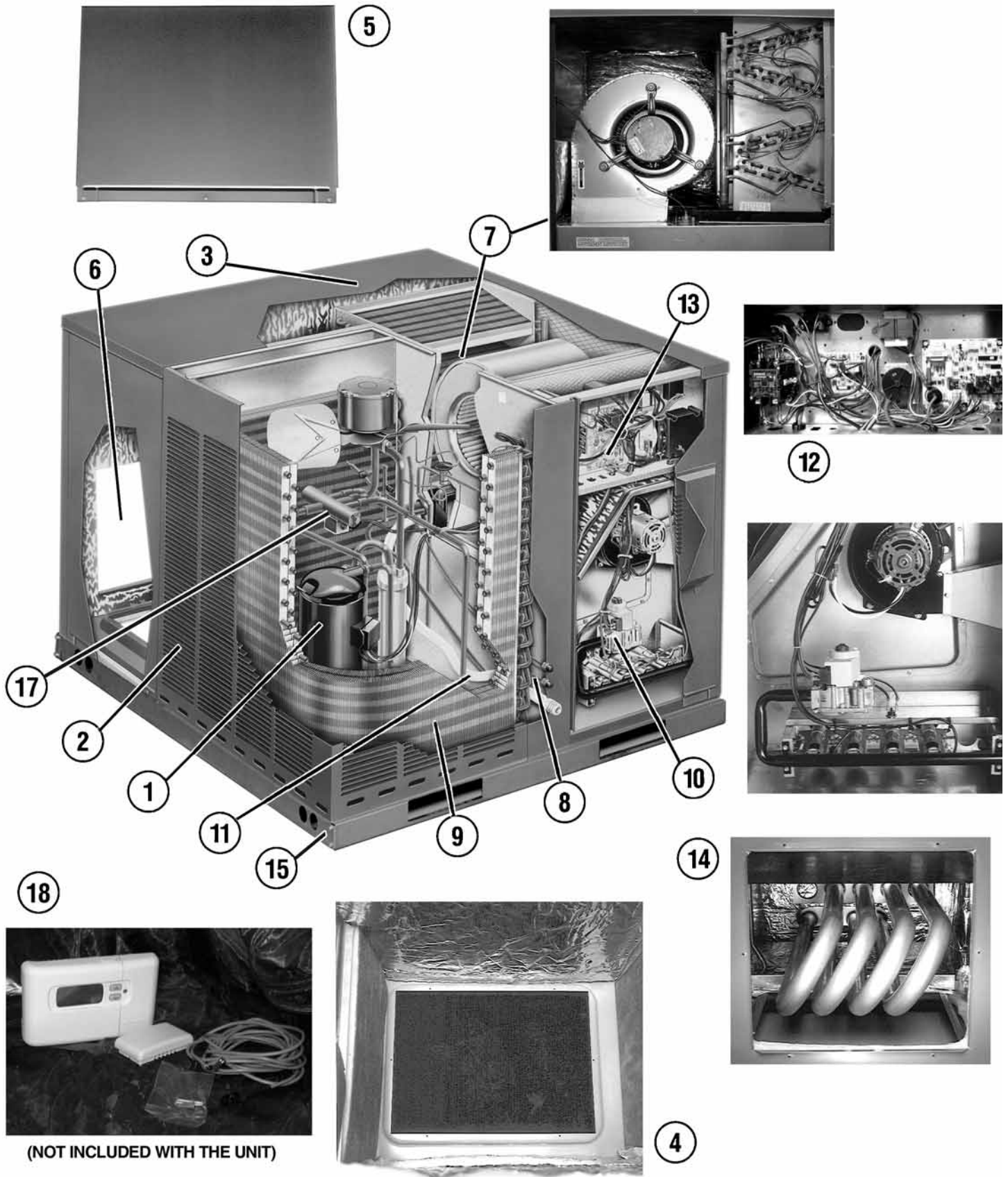

TABLE OF CONTENTS

Unit Features & Benefits	3-4
Model Number Identification	5
General Data	
RQPW- Series	6-13
General Data Notes	14
Gross Systems Performance Data	
RQPW- Series	15-20
Airflow Performance	
RQPW- Series	21-24
Electrical Data	
RQPW- Series	25
Dimensional Data	26-27
Typical Installations	28
Accessories	29-38
Wiring Diagrams	39-40
Limited Warranty	41



Package Dual Fuel Unit Feature:





Features Below Correspond to Photos on Page 3

1. A Package Dual Fuel Unit is a Package Heat Pump with a gas furnace installed in the heat section instead of electric heat that is in a standard Package Heat Pump. Generally, heating is satisfied by operation of the Heat Pump above a outdoor temperature balance point and below the outdoor temperature balance point the gas furnace is utilized to satisfy the heat requirement. This hybrid package system allows for both comfort and energy savings. It is more cost effective above the balance point to run electricity and the heat pump provides adequate supply air temperature at these outdoor temperatures to assure comfort. Below the balance point it is more economical and provides better comfort to utilize gas heat. All models feature Copeland® Scroll® compressors for maximum efficiency and quiet operation. This unit contains a special scroll compressor that is designed specifically to operate with R-410A Refrigerants and polyolester (POE) oils. The compressor is hermetically sealed and incorporates internal high temperature motor overload protection and durable insulation on the motor windings. It is externally mounted on rubber grommets to reduce vibration and noise.
2. Louvered condenser compartment for protecting the coil against yard hazards and/or weather extremes.
3. One-piece top with a deep flange to help keep water out of the unit.
4. Supply and return air openings feature a one-inch tall flange to prevent water migration into the ductwork.
5. Access panels have “weep holes” and channels to further help manage water run-off.
6. Side and down discharge options available on all models.
7. Easily accessible blower section complete with slide-out blower. All units feature a system matched indoor coil with low static pressure drop and excellent cooling capacities.
8. Refrigerant connections are conveniently located for easy service diagnostics.
9. Condenser and evaporator coils feature enhanced fins for better heat transfer and rifled copper tubing for greater efficiency.
10. Inside the easily accessible furnace compartment is the draft inducer motor. This motor is specially designed for quiet reliable operation. In addition to the draft inducer motor, the in-shot gas burners and manifold efficiently regulate the flow of gas for combustion. These new package dual fuel units also feature direct-spark ignition and remote flame sensors for added reliability and efficiency.
11. All units feature an internal trap on the condensate line eliminating the need for installing an on-site external trap.
12. Easily accessible control box. Package dual-fuel utilizes demand defrost control which monitors the outdoor ambient temperature, outdoor coil temperature, and compressor run-time to determine when a defrost cycle is required.
13. Single point wiring makes installation even easier.
14. Our package dual fuel units feature a tubular stainless steel heat exchanger design. Tubular heat exchangers are more efficient and durable than older-style clamshell heat exchangers and stainless steel is more corrosion resistant than aluminized steel. The heat exchanger is backed by a lifetime limited warranty.
15. Rugged Baseraill for improved installation and handling.
16. Filter Drier Standard on all models.
17. Reversing valve directs flow of refrigerant and reverses the refrigerant flow when heating is required.
18. The specially designed thermostat and outdoor ambient sensor offered by Rheem optimizes the performance of the package dual fuel unit. It is conveniently pre-programmed for quick trouble-free installation. (Not included with the unit) Model No. RHC-TST402DFMS.



Air

R Q P W — B 036 J K 08 E BVA

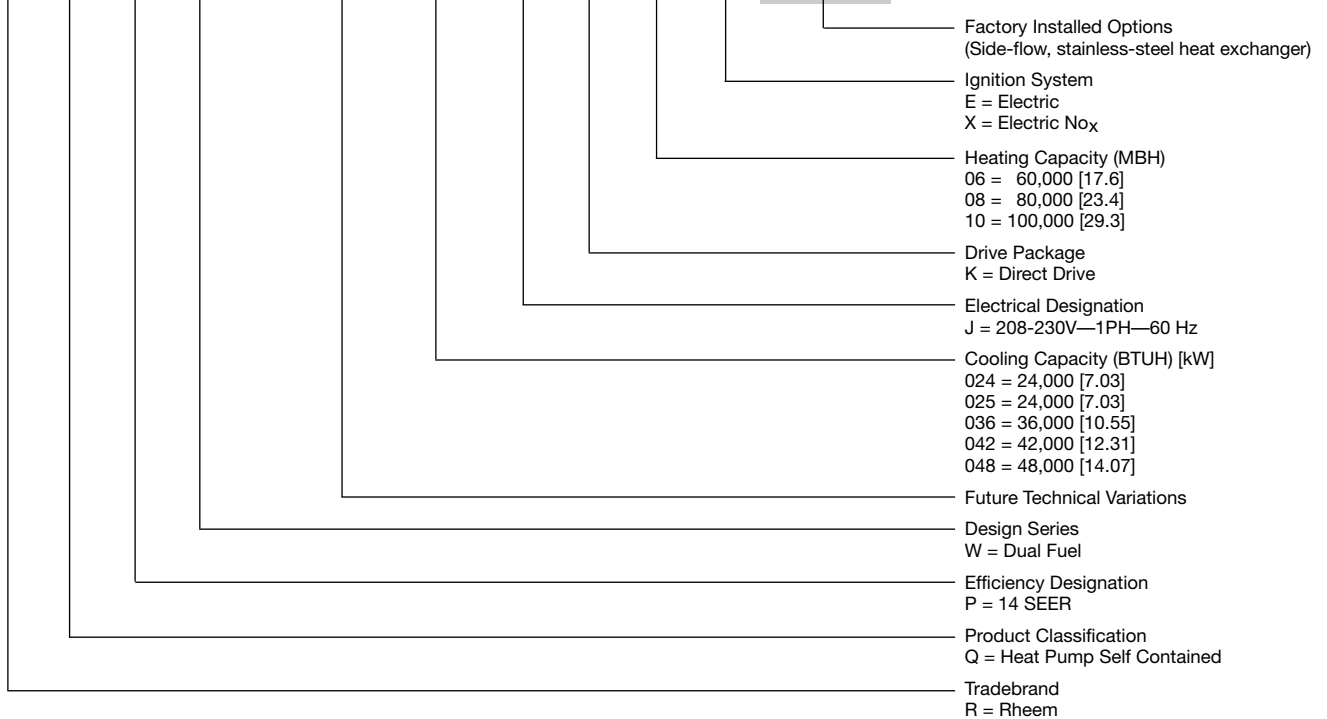

[] Designates Metric Conversions



NOMINAL SIZES 2-4 TONS [7.0-14.0 kW]

Model RQPW- Series	B024JK04E	B024JK04X	B024JK06E	B024JK06X
Cooling Performance				
Gross Cooling Capacity Btu [kW]	25,000 [7.32]	25,000 [7.32]	25,000 [7.32]	25,000 [7.32]
EER/SEER	11.8/14	11.8/14	11.8/14	11.8/14
Nominal CFM/AHRI Rated CFM [L/s]	800/850 [378/401]	800/850 [378/401]	800/850 [378/401]	800/850 [378/401]
AHRI Net Cooling Capacity Btu [kW]	24,400 [7.15]	24,400 [7.15]	24,400 [7.15]	24,400 [7.15]
Net Sensible Capacity Btu [kW]	18,900 [5.54]	18,900 [5.54]	18,900 [5.54]	18,900 [5.54]
Net Latent Capacity Btu [kW]	5,500 [1.61]	5,500 [1.61]	5,500 [1.61]	5,500 [1.61]
Net System Power kW	2.06	2.06	2.06	2.06
Heating Performance (Heat Pumps)				
High Temp. Btuh [kW] Rating	23,800 [6.97]	23,800 [6.97]	23,800 [6.97]	23,800 [6.97]
System Power KW / COP	1.94/3.5	1.94/3.5	1.94/3.5	1.94/3.5
Low Temp. Btuh [kW] Rating	13,800 [4.04]	13,800 [4.04]	13,800 [4.04]	13,800 [4.04]
System Power KW / COP	1.78/2.2	1.78/2.2	1.78/2.2	1.78/2.2
HSPF (Btu/Watts-hr)	8	8	8	8
Heating Performance (Gas)				
Heating Input Btu [kW]	40,000 [11.72]	40,000 [11.72]	60,000 [17.58]	60,000 [17.58]
Heating Output Btu [kW]	31,000 [9.08]	31,000 [9.08]	47,000 [13.77]	47,000 [13.77]
Temperature Rise Range °F [°C]	30-60 [16.7/33.3]	30-60 [16.7/33.3]	40-70 [22.2/38.9]	40-70 [22.2/38.9]
AFUE (%)	80	80	80	80
Steady State Efficiency (%)	81	81	81	81
No. Burners	2	2	3	3
No. Stages	1	1	1	1
Gas Connection Pipe Size in. [mm]	0.5 [12.7]	0.5 [12.7]	0.5 [12.7]	0.5 [12.7]
Compressor				
No./Type	1/Scroll	1/Scroll	1/Scroll	1/Scroll
Outdoor Sound Rating (dB)				
	76	76	76	76
Outdoor Coil Fin Type				
Tube Type	Louvered	Louvered	Louvered	Louvered
Tube Size in. [mm] OD	Rifled	Rifled	Rifled	Rifled
Face Area sq. ft. [sq. m]	0.375 [9.5]	0.375 [9.5]	0.375 [9.5]	0.375 [9.5]
Rows / FPI [FPcm]	14.51 [1.35]	14.51 [1.35]	14.51 [1.35]	14.51 [1.35]
Refrigerant Control	1 / 22 [9]	1 / 22 [9]	1 / 22 [9]	1 / 22 [9]
TX Valves	TX Valves	TX Valves	TX Valves	TX Valves
Indoor Coil Fin Type				
Tube Type	Louvered	Louvered	Louvered	Louvered
Tube Size in. [mm]	Rifled	Rifled	Rifled	Rifled
Face Area sq. ft. [sq. m]	0.375 [9.5]	0.375 [9.5]	0.375 [9.5]	0.375 [9.5]
Rows / FPI [FPcm]	5.54 [0.51]	5.54 [0.51]	5.54 [0.51]	5.54 [0.51]
Refrigerant Control	2 / 15 [6]	2 / 15 [6]	2 / 15 [6]	2 / 15 [6]
TX Valves	TX Valves	TX Valves	TX Valves	TX Valves
Drain Connection No./Size in. [mm]	1/1 [25.4]	1/1 [25.4]	1/1 [25.4]	1/1 [25.4]
Outdoor Fan Type				
Type	Propeller	Propeller	Propeller	Propeller
No. Used/Diameter in. [mm]	1/22 [558.8]	1/22 [558.8]	1/22 [558.8]	1/22 [558.8]
Drive Type/No. Speeds	Direct/1	Direct/1	Direct/1	Direct/1
CFM [L/s]	2700 [1274]	2700 [1274]	2700 [1274]	2700 [1274]
No. Motors/HP	1 at 1/3 HP	1 at 1/3 HP	1 at 1/3 HP	1 at 1/3 HP
Motor RPM	1075	1075	1075	1075
Indoor Fan Type				
Type	FC Centrifugal	FC Centrifugal	FC Centrifugal	FC Centrifugal
No. Used/Diameter in. [mm]	1/9x7 [229x178]	1/9x7 [229x178]	1/9x7 [229x178]	1/9x7 [229x178]
Drive Type/No. Speeds	Direct/4	Direct/4	Direct/4	Direct/4
No. Motors	1	1	1	1
Motor HP	1/3	1/3	1/3	1/3
Motor RPM	1050	1050	1050	1050
Motor Frame Size	48	48	48	48
Filter Type				
Type	Field Supplied	Field Supplied	Field Supplied	Field Supplied
Furnished	No	No	No	No
(No.) Size Recommended in. [mm]	(1)1x20x20 [25x508x508]	(1)1x20x20 [25x508x508]	(1)1x20x20 [25x508x508]	(1)1x20x20 [25x508x508]
Refrigerant Charge Oz. [g]	98 [2778]	98 [2778]	98 [2778]	98 [2778]
Weights				
Net Weight lbs. [kg]	435 [197]	435 [197]	440 [200]	440 [200]
Ship Weight lbs. [kg]	445 [202]	445 [202]	450 [204]	450 [204]

CONTINUED →

See Page 14 for Notes.

[] Designates Metric Conversions



NOMINAL SIZES 2-4 TONS [7.0-14.0 kW]

Model RQPW- Series	B024JK08E	B024JK08X	B025JK06E	B025JK06X
Cooling Performance				
Gross Cooling Capacity Btu [kW]	25,000 [7.32]	25,000 [7.32]	24,400 [7.15]	24,400 [7.15]
EER/SEER	11.8/14	11.8/14	12/14	12/14
Nominal CFM/AHRI Rated CFM [L/s]	800/850 [378/401]	800/850 [378/401]	800/850 [378/401]	800/850 [378/401]
AHRI Net Cooling Capacity Btu [kW]	24,400 [7.15]	24,400 [7.15]	23,800 [6.97]	23,800 [6.97]
Net Sensible Capacity Btu [kW]	18,900 [5.54]	18,900 [5.54]	17,800 [5.22]	17,800 [5.22]
Net Latent Capacity Btu [kW]	5,500 [1.61]	5,500 [1.61]	6,000 [1.76]	6,000 [1.76]
Net System Power kW	2.06	2.06	1.98	1.98
Heating Performance (Heat Pumps)				
High Temp. Btuh [kW] Rating	23,800 [6.97]	23,800 [6.97]	23,600 [6.91]	23,600 [6.91]
System Power KW / COP	1.94/3.5	1.94/3.5	1.88/3.7	1.88/3.7
Low Temp. Btuh [kW] Rating	13,800 [4.04]	13,800 [4.04]	12,900 [3.78]	12,900 [3.78]
System Power KW / COP	1.78/2.2	1.78/2.2	1.7/2.24	1.7/2.24
HSPF (Btu/Watts-hr)	8	8	8	8
Heating Performance (Package Gas/Electric)				
Heating Input Btu [kW]	80,000 [23.44]	80,000 [23.44]	60,000 [17.58]	60,000 [17.58]
Heating Output Btu [kW]	62,000 [18.17]	62,000 [18.17]	47,000 [13.77]	47,000 [13.77]
Temperature Rise Range Δ F [Δ C]	55-85 [30.6/47.2]	55-85 [30.6/47.2]	40-70 [22.2/38.9]	40-70 [22.2/38.9]
AFUE (%)	80	80	80	80
Steady State Efficiency (%)	81	81	81	81
No. Burners	4	4	3	3
No. Stages	1	1	1	1
Gas Connection Pipe Size in. [mm]	0.5 [12.7]	0.5 [12.7]	0.5 [12.7]	0.5 [12.7]
Compressor				
No./Type	1/Scroll	1/Scroll	1/Scroll	1/Scroll
Outdoor Sound Rating (dB)				
	76	76	76	76
Outdoor Coil Fin Type				
Tube Type	Louvered	Louvered	Louvered	Louvered
Tube Size in. [mm] OD	Rifled	Rifled	Rifled	Rifled
Face Area sq. ft. [sq. m]	0.375 [9.5]	0.375 [9.5]	0.375 [9.5]	0.375 [9.5]
Rows / FPI [FPcm]	14.51 [1.35]	14.51 [1.35]	14.51 [1.35]	14.51 [1.35]
Refrigerant Control	1 / 22 [9]	1 / 22 [9]	1 / 22 [9]	1 / 22 [9]
	TX Valves	TX Valves	TX Valves	TX Valves
Indoor Coil Fin Type				
Tube Type	Louvered	Louvered	Louvered	Louvered
Tube Size in. [mm]	Rifled	Rifled	Rifled	Rifled
Face Area sq. ft. [sq. m]	0.375 [9.5]	0.375 [9.5]	0.375 [9.5]	0.375 [9.5]
Rows / FPI [FPcm]	5.54 [0.51]	5.54 [0.51]	5.54 [0.51]	5.54 [0.51]
Refrigerant Control	2 / 15 [6]	2 / 15 [6]	2 / 15 [6]	2 / 15 [6]
Drain Connection No./Size in. [mm]	TX Valves	TX Valves	TX Valves	TX Valves
	1/1 [25.4]	1/1 [25.4]	1/1 [25.4]	1/1 [25.4]
Outdoor Fan Type				
No. Used/Diameter in. [mm]	Propeller	Propeller	Propeller	Propeller
Drive Type/No. Speeds	1/22 [558.8]	1/22 [558.8]	1/22 [558.8]	1/22 [558.8]
CFM [L/s]	Direct/1	Direct/1	Direct/1	Direct/1
No. Motors/HP	2700 [1274]	2700 [1274]	2700 [1274]	2700 [1274]
Motor RPM	1 at 1/3 HP	1 at 1/3 HP	1 at 1/3 HP	1 at 1/3 HP
	1075	1075	869	869
Indoor Fan Type				
No. Used/Diameter in. [mm]	FC Centrifugal	FC Centrifugal	FC Centrifugal	FC Centrifugal
Drive Type/No. Speeds	1/9x7 [229x178]	1/9x7 [229x178]	1/9x7 [229x178]	1/9x7 [229x178]
No. Motors	Direct/4	Direct/4	Direct/4	Direct/4
Motor HP	1	1	1	1
Motor RPM	1/3	1/3	1/3	1/3
Motor Frame Size	1050	1050	869	869
	48	48	48	48
Filter Type				
Furnished	Field Supplied	Field Supplied	Field Supplied	Field Supplied
(No.) Size Recommended in. [mm]	No	No	No	No
	(1)1x20x20 [25x508x508]	(1)1x20x20 [25x508x508]	(1)1x20x20 [25x508x508]	(1)1x20x20 [25x508x508]
Refrigerant Charge Oz. [g]				
	98 [2778]	98 [2778]	98 [2778]	98 [2778]
Weights				
Net Weight lbs. [kg]	445 [202]	445 [202]	440 [200]	440 [200]
Ship Weight lbs. [kg]	455 [206]	455 [206]	450 [204]	450 [204]

See Page 14 for Notes.

[] Designates Metric Conversions



NOMINAL SIZES 2-4 TONS [7.0-14.0 kW]

Model RQPW- Series	B025JK08E	B025JK08X	B030JK04E	B030JK04X
Cooling Performance				
Gross Cooling Capacity Btu [kW]	24,400 [7.15]	24,400 [7.15]	29,800 [8.73]	29,800 [8.73]
EER/SEER	12/14	12/14	12/14	12/14
Nominal CFM/AHRI Rated CFM [L/s]	800/850 [378/401]	800/850 [378/401]	1000/1050 [472/495]	1000/1050 [472/495]
AHRI Net Cooling Capacity Btu [kW]	23,800 [6.97]	23,800 [6.97]	29,200 [8.56]	29,200 [8.56]
Net Sensible Capacity Btu [kW]	17,800 [5.22]	17,800 [5.22]	23,000 [6.74]	23,000 [6.74]
Net Latent Capacity Btu [kW]	6,000 [1.76]	6,000 [1.76]	6,200 [1.82]	6,200 [1.82]
Net System Power kW	1.98	1.98	2.43	2.43
Heating Performance (Heat Pumps)				
High Temp. Btuh [kW] Rating	23,600 [6.91]	23,600 [6.91]	27,800 [8.15]	27,800 [8.15]
System Power KW / COP	1.88/3.7	1.88/3.7	2.27/3.6	2.27/3.6
Low Temp. Btuh [kW] Rating	12,900 [3.78]	12,900 [3.78]	15,500 [4.54]	15,500 [4.54]
System Power KW / COP	1.7/2.24	1.7/2.24	2.07/2.2	2.07/2.2
HSPF (Btu/Watts-hr)	8	8	8	8
Heating Performance (Package Gas/Electric)				
Heating Input Btu [kW]	80,000 [23.44]	80,000 [23.44]	40,000 [11.72]	40,000 [11.72]
Heating Output Btu [kW]	62,000 [18.17]	62,000 [18.17]	31,000 [9.08]	31,000 [9.08]
Temperature Rise Range Δ F [Δ C]	55-85 [30.6/47.2]	55-85 [30.6/47.2]	20-50 [11.1/27.8]	20-50 [11.1/27.8]
AFUE (%)	80	80	80	80
Steady State Efficiency (%)	81	81	81	81
No. Burners	4	4	2	2
No. Stages	1	1	1	1
Gas Connection Pipe Size in. [mm]	0.5 [12.7]	0.5 [12.7]	0.5 [12.7]	0.5 [12.7]
Compressor				
No./Type	1/Scroll	1/Scroll	1/Scroll	1/Scroll
Outdoor Sound Rating (dB)				
	76	76	76	76
Outdoor Coil/Fin Type				
Tube Type	Louvered	Louvered	Louvered	Louvered
Tube Size in. [mm] OD	Rifled	Rifled	Rifled	Rifled
Face Area sq. ft. [sq. m]	0.375 [9.5]	0.375 [9.5]	0.375 [9.5]	0.375 [9.5]
Rows / FPI [FPcm]	14.51 [1.35]	14.51 [1.35]	16.32 [1.52]	16.32 [1.52]
Refrigerant Control	1 / 22 [9]	1 / 22 [9]	1 / 22 [9]	1 / 22 [9]
Indoor Coil/Fin Type				
Tube Type	Louvered	Louvered	Louvered	Louvered
Tube Size in. [mm]	Rifled	Rifled	Rifled	Rifled
Face Area sq. ft. [sq. m]	0.375 [9.5]	0.375 [9.5]	0.375 [9.5]	0.375 [9.5]
Rows / FPI [FPcm]	5.54 [0.51]	5.54 [0.51]	7.39 [0.69]	7.39 [0.69]
Refrigerant Control	2 / 15 [6]	2 / 15 [6]	2 / 15 [6]	2 / 15 [6]
Drain Connection No./Size in. [mm]	TX Valves	TX Valves	TX Valves	TX Valves
Outdoor Fan/Type				
No. Used/Diameter in. [mm]	Propeller	Propeller	Propeller	Propeller
Drive Type/No. Speeds	1/22 [558.8]	1/22 [558.8]	1/22 [558.8]	1/22 [558.8]
CFM [L/s]	Direct/1	Direct/1	Direct/1	Direct/1
No. Motors/HP	2700 [1274]	2700 [1274]	2700 [1274]	2700 [1274]
Motor RPM	1 at 1/3 HP	1 at 1/3 HP	1 at 1/3 HP	1 at 1/3 HP
Indoor Fan/Type				
No. Used/Diameter in. [mm]	FC Centrifugal	FC Centrifugal	FC Centrifugal	FC Centrifugal
Drive Type/No. Speeds	1/9x7 [229x178]	1/9x7 [229x178]	1/10x9 [254x229]	1/10x9 [254x229]
No. Motors	Direct/4	Direct/4	Direct/5	Direct/5
Motor HP	1	1	1	1
Motor RPM	1/3	1/3	1/2	1/2
Motor Frame Size	869	869	1050	1050
Filter/Type				
Furnished	Field Supplied	Field Supplied	Field Supplied	Field Supplied
(No.) Size Recommended in. [mm]	No	No	No	No
Refrigerant Charge Oz. [g]	(1)1x20x20 [25x508x508]	(1)1x20x20 [25x508x508]	(1)1x24x24 [25x610x610]	(1)1x24x24 [25x610x610]
Weights				
Net Weight lbs. [kg]	98 [2778]	98 [2778]	108 [3062]	108 [3062]
Ship Weight lbs. [kg]				
	445 [202]	445 [202]	475 [215]	475 [215]
	455 [206]	455 [206]	486 [220]	486 [220]

CONTINUED 

See Page 14 for Notes.

[] Designates Metric Conversions



NOMINAL SIZES 2-4 TONS [7.0-14.0 kW]

Model RQPW- Series	B030JK06E	B030JK06X	B030JK08E	B030JK08X
Cooling Performance				
				CONTINUED →
Gross Cooling Capacity Btu [kW]	29,800 [8.73]	29,800 [8.73]	29,800 [8.73]	29,800 [8.73]
EER/SEER	12/14	12/14	12/14	12/14
Nominal CFM/AHRI Rated CFM [L/s]	1000/1050 [472/495]	1000/1050 [472/495]	1000/1050 [472/495]	1000/1050 [472/495]
AHRI Net Cooling Capacity Btu [kW]	29,200 [8.56]	29,200 [8.56]	29,200 [8.56]	29,200 [8.56]
Net Sensible Capacity Btu [kW]	23,000 [6.74]	23,000 [6.74]	23,000 [6.74]	23,000 [6.74]
Net Latent Capacity Btu [kW]	6,200 [1.82]	6,200 [1.82]	6,200 [1.82]	6,200 [1.82]
Net System Power kW	2.43	2.43	2.43	2.43
Heating Performance (Heat Pumps)				
High Temp. Btuh [kW] Rating	27,800 [8.15]	27,800 [8.15]	27,800 [8.15]	27,800 [8.15]
System Power KW / COP	2.27/3.6	2.27/3.6	2.27/3.6	2.27/3.6
Low Temp. Btuh [kW] Rating	15,500 [4.54]	15,500 [4.54]	15,500 [4.54]	15,500 [4.54]
System Power KW / COP	2.07/2.2	2.07/2.2	2.07/2.2	2.07/2.2
HSPF (Btu/Watts-hr)	8	8	8	8
Heating Performance (Package Gas/Electric)				
Heating Input Btu [kW]	60,000 [17.58]	60,000 [17.58]	80,000 [23.44]	80,000 [23.44]
Heating Output Btu [kW]	47,000 [13.77]	47,000 [13.77]	62,000 [18.17]	62,000 [18.17]
Temperature Rise Range ΔF [ΔC]	30-60 [16.7/33.3]	30-60 [16.7/33.3]	40-70 [22.2/38.9]	40-70 [22.2/38.9]
AFUE (%)	80	80	80	80
Steady State Efficiency (%)	81	81	81	81
No. Burners	3	3	4	4
No. Stages	1	1	1	1
Gas Connection Pipe Size in. [mm]	0.5 [12.7]	0.5 [12.7]	0.5 [12.7]	0.5 [12.7]
Compressor				
No./Type	1/Scroll	1/Scroll	1/Scroll	1/Scroll
Outdoor Sound Rating (dB)				
	76	76	76	76
Outdoor Coil Fin Type				
Tube Type	Louvered	Louvered	Louvered	Louvered
Tube Size in. [mm] OD	Rifled	Rifled	Rifled	Rifled
Face Area sq. ft. [sq. m]	0.375 [9.5]	0.375 [9.5]	0.375 [9.5]	0.375 [9.5]
Rows / FPI [FPcm]	16.32 [1.52]	16.32 [1.52]	16.32 [1.52]	16.32 [1.52]
Refrigerant Control	1 / 22 [9]	1 / 22 [9]	1 / 22 [9]	1 / 22 [9]
	TX Valves	TX Valves	TX Valves	TX Valves
Indoor Coil Fin Type				
Tube Type	Louvered	Louvered	Louvered	Louvered
Tube Size in. [mm]	Rifled	Rifled	Rifled	Rifled
Face Area sq. ft. [sq. m]	0.375 [9.5]	0.375 [9.5]	0.375 [9.5]	0.375 [9.5]
Rows / FPI [FPcm]	7.39 [0.69]	7.39 [0.69]	7.39 [0.69]	7.39 [0.69]
Refrigerant Control	2 / 15 [6]	2 / 15 [6]	2 / 15 [6]	2 / 15 [6]
	TX Valves	TX Valves	TX Valves	TX Valves
Drain Connection No./Size in. [mm]	TX Valves	TX Valves	TX Valves	TX Valves
	1/1 [25.4]	1/1 [25.4]	1/1 [25.4]	1/1 [25.4]
Outdoor Fan Type				
No. Used/Diameter in. [mm]	Propeller	Propeller	Propeller	Propeller
Drive Type/No. Speeds	1/22 [558.8]	1/22 [558.8]	1/22 [558.8]	1/22 [558.8]
CFM [L/s]	Direct/1	Direct/1	Direct/1	Direct/1
No. Motors/HP	2700 [1274]	2700 [1274]	2700 [1274]	2700 [1274]
Motor RPM	1 at 1/3 HP	1 at 1/3 HP	1 at 1/3 HP	1 at 1/3 HP
	1075	1075	1075	1075
Indoor Fan Type				
No. Used/Diameter in. [mm]	FC Centrifugal	FC Centrifugal	FC Centrifugal	FC Centrifugal
Drive Type/No. Speeds	1/10x9 [254x229]	1/10x9 [254x229]	1/10x9 [254x229]	1/10x9 [254x229]
No. Motors	Direct/5	Direct/5	Direct/5	Direct/5
Motor HP	1	1	1	1
Motor RPM	1/2	1/2	1/2	1/2
Motor Frame Size	1050	1050	1050	1050
	48	48	48	48
Filter Type				
Furnished	Field Supplied	Field Supplied	Field Supplied	Field Supplied
(No.) Size Recommended in. [mm]	No	No	No	No
	(1)1x24x24 [25x610x610]	(1)1x24x24 [25x610x610]	(1)1x24x24 [25x610x610]	(1)1x24x24 [25x610x610]
Refrigerant Charge Oz. [g]				
	108 [3062]	108 [3062]	108 [3062]	108 [3062]
Weights				
Net Weight lbs. [kg]	480 [218]	480 [218]	485 [220]	485 [220]
Ship Weight lbs. [kg]	491 [223]	491 [223]	496 [225]	496 [225]

See Page 14 for Notes.

[] Designates Metric Conversions



NOMINAL SIZES 2-4 TONS [7.0-14.0 kW]

Model RQPW- Series	B030JK10E	B030JK10X	B036CK04E	B036CK06E
Model RQPW- Series	B030JK10E	B030JK10X	B036CK04E	B036CK06E
Cooling Performance				CONTINUED →
Gross Cooling Capacity Btu [kW]	29,800 [8.73]	29,800 [8.73]	36,800 [10.78]	36,800 [10.78]
EER/SEER	12/14	12/14	12/14	12/14
Nominal CFM/AHRI Rated CFM [L/s]	1000/1050 [472/495]	1000/1050 [472/495]	1200/1250 [566/590]	1200/1250 [566/590]
AHRI Net Cooling Capacity Btu [kW]	29,200 [8.56]	29,200 [8.56]	36,000 [10.55]	36,000 [10.55]
Net Sensible Capacity Btu [kW]	23,000 [6.74]	23,000 [6.74]	27,000 [7.91]	27,000 [7.91]
Net Latent Capacity Btu [kW]	6,200 [1.82]	6,200 [1.82]	9,000 [2.64]	9,000 [2.64]
Net System Power kW	2.43	2.43	3	3
Heating Performance (Heat Pumps)				
High Temp. Btuh [kW] Rating	27,800 [8.15]	27,800 [8.15]	33,200 [9.73]	33,200 [9.73]
System Power KW / COP	2.27/3.6	2.27/3.6	2.73/3.6	2.73/3.6
Low Temp. Btuh [kW] Rating	15,500 [4.54]	15,500 [4.54]	18,000 [5.27]	18,000 [5.27]
System Power KW / COP	2.07/2.2	2.07/2.2	2.5/2.2	2.5/2.2
HSPF (Btu/Watts-hr)	8	8	8	8
Heating Performance (Gas)				
Heating Input Btu [kW]	100,000 [29.3]	100,000 [29.3]	40,000 [11.72]	60,000 [17.58]
Heating Output Btu [kW]	77,000 [22.56]	77,000 [22.56]	32,400 [9.49]	48,600 [14.24]
Temperature Rise Range °F [°C]	45-85 [25/47.2]	45-85 [25/47.2]	20-50 [11.1/27.8]	30-60 [16.7/33.3]
AFUE (%)	80	80	80	80
Steady State Efficiency (%)	81	81	81	81
No. Burners	5	5	2	3
No. Stages	1	1	1	1
Gas Connection Pipe Size in. [mm]	0.5 [12.7]	0.5 [12.7]	0.5 [12.7]	0.5 [12.7]
Compressor				
No./Type	1/Scroll	1/Scroll	1/Scroll	1/Scroll
Outdoor Sound Rating (dB)	76	76	76	76
Outdoor Coil Fin Type	Louvered	Louvered	Louvered	Louvered
Tube Type	Rifled	Rifled	Rifled	Rifled
Tube Size in. [mm] OD	0.375 [9.5]	0.375 [9.5]	0.375 [9.5]	0.375 [9.5]
Face Area sq. ft. [sq. m]	16.32 [1.52]	16.32 [1.52]	11.2 [1.04]	11.2 [1.04]
Rows / FPI [FPcm]	1 / 22 [9]	1 / 22 [9]	2 / 22 [9]	2 / 22 [9]
Refrigerant Control	TX Valves	TX Valves	TX Valves	TX Valves
Indoor Coil Fin Type	Louvered	Louvered	Louvered	Louvered
Tube Type	Rifled	Rifled	Rifled	Rifled
Tube Size in. [mm]	0.375 [9.5]	0.375 [9.5]	0.375 [9.5]	0.375 [9.5]
Face Area sq. ft. [sq. m]	7.39 [0.69]	7.39 [0.69]	7.39 [0.69]	7.39 [0.69]
Rows / FPI [FPcm]	2 / 15 [6]	2 / 15 [6]	2 / 15 [6]	2 / 15 [6]
Refrigerant Control	TX Valves	TX Valves	TX Valves	TX Valves
Drain Connection No./Size in. [mm]	1/1 [25.4]	1/1 [25.4]	1/1 [25.4]	1/1 [25.4]
Outdoor Fan Type	Propeller	Propeller	Propeller	Propeller
No. Used/Diameter in. [mm]	1/22 [558.8]	1/22 [558.8]	1/22 [558.8]	1/22 [558.8]
Drive Type/No. Speeds	Direct/1	Direct/1	Direct/1	Direct/1
CFM [L/s]	2700 [1274]	2700 [1274]	2700 [1274]	2700 [1274]
No. Motors/HP	1 at 1/3 HP	1 at 1/3 HP	1 at 1/3 HP	1 at 1/3 HP
Motor RPM	1075	1075	1075	1075
Indoor Fan Type	FC Centrifugal	FC Centrifugal	FC Centrifugal	FC Centrifugal
No. Used/Diameter in. [mm]	1/10x9 [254x229]	1/10x9 [254x229]	1/10x9 [254x229]	1/10x9 [254x229]
Drive Type/No. Speeds	Direct/5	Direct/5	Direct/5	Direct/5
No. Motors	1	1	1	1
Motor HP	1/2	1/2	1/2	1/2
Motor RPM	1050	1050	1050	1050
Motor Frame Size	48	48	48	48
Filter Type	Field Supplied	Field Supplied	Field Supplied	Field Supplied
Furnished	No	No	No	No
(No.) Size Recommended in. [mm]	(1)1x24x24 [25x610x610]	(1)1x24x24 [25x610x610]	(1)1x24x24 [25x610x610]	(1)1x24x24 [25x610x610]
Refrigerant Charge Oz. [g]	108 [3062]	108 [3062]	146 [4139]	146 [4139]
Weights				
Net Weight lbs. [kg]	490 [222]	490 [222]	496 [225]	501 [227]
Ship Weight lbs. [kg]	501 [227]	501 [227]	507 [230]	512 [232]

See Page 14 for Notes.

[] Designates Metric Conversions

NOMINAL SIZES 2-4 TONS [7.0-14.0 kW]

Model RQPW- Series	B036CK08E	B036JK08E	B036JK08X	B036JK10E
				CONTINUED →
Cooling Performance				
Gross Cooling Capacity Btu [kW]	36,800 [10.78]	36,800 [10.78]	36,800 [10.78]	36,800 [10.78]
EER/SEER	12/14	12/14	12/14	12/14
Nominal CFM/AHRI Rated CFM [L/s]	1200/1250 [566/590]	1200/1250 [566/590]	1200/1250 [566/590]	1200/1250 [566/590]
AHRI Net Cooling Capacity Btu [kW]	36,000 [10.55]	36,000 [10.55]	36,000 [10.55]	36,000 [10.55]
Net Sensible Capacity Btu [kW]	27,000 [7.91]	27,000 [7.91]	27,000 [7.91]	27,000 [7.91]
Net Latent Capacity Btu [kW]	9,000 [2.64]	9,000 [2.64]	9,000 [2.64]	9,000 [2.64]
Net System Power kW	3	3	3	3
Heating Performance (Heat Pumps)				
High Temp. Btuh [kW] Rating	33,200 [9.73]	33,200 [9.73]	33,200 [9.73]	33,200 [9.73]
System Power KW / COP	2.73/3.6	2.73/3.6	2.73/3.6	2.73/3.6
Low Temp. Btuh [kW] Rating	18,000 [5.27]	18,000 [5.27]	18,000 [5.27]	18,000 [5.27]
System Power KW / COP	2.5/2.2	2.5/2.2	2.5/2.2	2.5/2.2
HSPF (Btu/Watts-hr)	8	8	8	8
Heating Performance (Package Gas/Electric)				
Heating Input Btu [kW]	80,000 [23.44]	80,000 [23.44]	80,000 [23.44]	100,000 [29.3]
Heating Output Btu [kW]	64,800 [18.99]	62,000 [18.17]	62,000 [18.17]	77,000 [22.56]
Temperature Rise Range Δ T [°C]	40-70 [22.2/38.9]	40-70 [22.2/38.9]	40-70 [22.2/38.9]	45-85 [25/47.2]
AFUE (%)	80	80	80	80
Steady State Efficiency (%)	81	81	81	81
No. Burners	4	4	4	5
No. Stages	1	1	1	1
Gas Connection Pipe Size in. [mm]	0.5 [12.7]	0.5 [12.7]	0.5 [12.7]	0.5 [12.7]
Compressor				
No./Type	1/Scroll	1/Scroll	1/Scroll	1/Scroll
Outdoor Sound Rating (dB)				
	76	76	76	76
Outdoor Coil/Fin Type				
Tube Type	Louvered	Louvered	Louvered	Louvered
Tube Size in. [mm] OD	Rifled	Rifled	Rifled	Rifled
Face Area sq. ft. [sq. m]	0.375 [9.5]	0.375 [9.5]	0.375 [9.5]	0.375 [9.5]
Rows / FPI [FPcm]	11.2 [1.04]	11.2 [1.04]	11.2 [1.04]	11.2 [1.04]
Refrigerant Control	2 / 22 [9]	2 / 22 [9]	2 / 22 [9]	2 / 22 [9]
	TX Valves	TX Valves	TX Valves	TX Valves
Indoor Coil/Fin Type				
Tube Type	Louvered	Louvered	Louvered	Louvered
Tube Size in. [mm]	Rifled	Rifled	Rifled	Rifled
Face Area sq. ft. [sq. m]	0.375 [9.5]	0.375 [9.5]	0.375 [9.5]	0.375 [9.5]
Rows / FPI [FPcm]	7.39 [0.69]	7.39 [0.69]	7.39 [0.69]	7.39 [0.69]
Refrigerant Control	2 / 15 [6]	2 / 15 [6]	2 / 15 [6]	2 / 15 [6]
Drain Connection No./Size in. [mm]	TX Valves	TX Valves	TX Valves	TX Valves
	1/1 [25.4]	1/1 [25.4]	1/1 [25.4]	1/1 [25.4]
Outdoor Fan/Type				
No. Used/Diameter in. [mm]	Propeller	Propeller	Propeller	Propeller
Drive Type/No. Speeds	1/22 [558.8]	1/22 [558.8]	1/22 [558.8]	1/22 [558.8]
CFM [L/s]	Direct/1	Direct/1	Direct/1	Direct/1
No. Motors/HP	2700 [1274]	2700 [1274]	2700 [1274]	2700 [1274]
Motor RPM	1 at 1/3 HP	1 at 1/3 HP	1 at 1/3 HP	1 at 1/3 HP
	1075	1075	1075	1075
Indoor Fan/Type				
No. Used/Diameter in. [mm]	FC Centrifugal	FC Centrifugal	FC Centrifugal	FC Centrifugal
Drive Type/No. Speeds	1/10x9 [254x229]	1/10x9 [254x229]	1/10x9 [254x229]	1/10x9 [254x229]
No. Motors	Direct/5	Direct/3	Direct/3	Direct/3
Motor HP	1	1	1	1
Motor RPM	1/2	1/2	1/2	1/2
Motor Frame Size	1050	1050	1050	1050
	48	48	48	48
Filter/Type				
Furnished	Field Supplied	Field Supplied	Field Supplied	Field Supplied
(No.) Size Recommended in. [mm]	No	No	No	No
	(1)1x24x24 [25x610x610]	(1)1x24x24 [25x610x610]	(1)1x24x24 [25x610x610]	(1)1x24x24 [25x610x610]
Refrigerant Charge Oz. [g]	146 [4139]	146 [4139]	146 [4139]	146 [4139]
Weights				
Net Weight lbs. [kg]	506 [230]	468 [212]	468 [212]	468 [212]
Ship Weight lbs. [kg]	517 [235]	479 [217]	479 [217]	479 [217]

See Page 14 for Notes.

[] Designates Metric Conversions



NOMINAL SIZES 2-4 TONS [7.0-14.0 kW]

Model RQPW- Series	B036JK10X	B042JK10E	B042JK10X	B048JK10E
Cooling Performance				
Gross Cooling Capacity Btu [kW]	36,800 [10.78]	43,500 [12.75]	43,500 [12.75]	49,000 [14.36]
EER/SEER	12/14	11.3/14	11.3/14	11.5/14
Nominal CFM/AHRI Rated CFM [L/s]	1200/1250 [566/590]	1400/1400 [661/661]	1400/1400 [661/661]	1600/1600 [755/755]
AHRI Net Cooling Capacity Btu [kW]	36,000 [10.55]	42,500 [12.45]	42,500 [12.45]	47,500 [13.92]
Net Sensible Capacity Btu [kW]	27,000 [7.91]	31,500 [9.23]	31,500 [9.23]	36,000 [10.55]
Net Latent Capacity Btu [kW]	9,000 [2.64]	11,000 [3.22]	11,000 [3.22]	11,500 [3.37]
Net System Power kW	3	3.76	3.76	4.13
Heating Performance (Heat Pumps)				
High Temp. Btuh [kW] Rating	33,200 [9.73]	41,500 [12.16]	41,500 [12.16]	46,000 [13.48]
System Power KW / COP	2.73/3.6	3.65/3.4	3.65/3.4	3.89/3.44
Low Temp. Btuh [kW] Rating	18,000 [5.27]	24,200 [7.09]	24,200 [7.09]	26,600 [7.79]
System Power KW / COP	2.5/2.2	3.43/2.08	3.43/2.08	3.57/2.2
HSPF (Btu/Watts-hr)	8	8	8	8
Heating Performance (Package Gas/Electric)				
Heating Input Btu [kW]	100,000 [29.3]	100,000 [29.3]	100,000 [29.3]	100,000 [29.3]
Heating Output Btu [kW]	77,000 [22.56]	77,000 [22.56]	77,000 [22.56]	77,000 [22.56]
Temperature Rise Range °F [°C]	45-85 [25/47.2]	45-85 [25/47.2]	45-85 [25/47.2]	45-85 [25/47.2]
AFUE (%)	80	80	80	80
Steady State Efficiency (%)	81	81	81	81
No. Burners	5	5	5	5
No. Stages	1	1	1	1
Gas Connection Pipe Size in. [mm]	0.5 [12.7]	0.5 [12.7]	0.5 [12.7]	0.5 [12.7]
Compressor				
No./Type	1/Scroll	1/Scroll	1/Scroll	1/Scroll
Outdoor Sound Rating (dB)				
	76	76	76	78
Outdoor Coil/Fin Type				
Tube Type	Louvered	Louvered	Louvered	Louvered
Tube Size in. [mm] OD	Rifled	Rifled	Rifled	Rifled
Face Area sq. ft. [sq. m]	0.375 [9.5]	0.375 [9.5]	0.375 [9.5]	0.375 [9.5]
Rows / FPI [FPcm]	11.2 [1.04]	16.32 [1.52]	16.32 [1.52]	16.32 [1.52]
Refrigerant Control	2 / 22 [9]	2 / 22 [9]	2 / 22 [9]	2 / 22 [9]
	TX Valves	TX Valves	TX Valves	TX Valves
Indoor Coil/Fin Type				
Tube Type	Louvered	Louvered	Louvered	Louvered
Tube Size in. [mm]	Rifled	Rifled	Rifled	Rifled
Face Area sq. ft. [sq. m]	0.375 [9.5]	0.375 [9.5]	0.375 [9.5]	0.375 [9.5]
Rows / FPI [FPcm]	7.39 [0.69]	7.39 [0.69]	7.39 [0.69]	7.39 [0.69]
Refrigerant Control	2 / 15 [6]	2 / 15 [6]	2 / 15 [6]	2 / 15 [6]
	TX Valves	TX Valves	TX Valves	TX Valves
Drain Connection No./Size in. [mm]	1/1 [25.4]	1/1 [25.4]	1/1 [25.4]	1/1 [25.4]
Outdoor Fan/Type				
No. Used/Diameter in. [mm]	Propeller	Propeller	Propeller	Propeller
Drive Type/No. Speeds	1/22 [558.8]	1/22 [558.8]	1/22 [558.8]	1/22 [558.8]
CFM [L/s]	Direct/1	Direct/1	Direct/1	Direct/1
No. Motors/HP	2700 [1274]	3300 [1557]	3300 [1557]	3000 [1416]
Motor RPM	1 at 1/3 HP	1 at 1/3 HP	1 at 1/3 HP	1 at 1/3 HP
	1075	1075	1075	1075
Indoor Fan/Type				
No. Used/Diameter in. [mm]	FC Centrifugal	FC Centrifugal	FC Centrifugal	FC Centrifugal
Drive Type/No. Speeds	1/10x9 [254x229]	1/10x9 [254x229]	1/10x9 [254x229]	1/10x9 [254x229]
No. Motors	Direct/3	Direct/2	Direct/2	Direct/2
Motor HP	1	1	1	1
Motor RPM	1/2	3/4	3/4	3/4
Motor Frame Size	1050	1075	1075	1075
	48	48	48	48
Filter/Type				
Furnished	Field Supplied	Field Supplied	Field Supplied	Field Supplied
(No.) Size Recommended in. [mm]	No	No	No	No
	(1)1x24x24 [25x610x610]	(1)1x24x24 [25x610x610]	(1)1x24x24 [25x610x610]	(1)1x24x24 [25x610x610]
Refrigerant Charge Oz. [g]				
	146 [4139]	176 [4990]	176 [4990]	183 [5188]
Weights				
Net Weight lbs. [kg]	468 [212]	505 [229]	505 [229]	510 [231]
Ship Weight lbs. [kg]	479 [217]	516 [234]	516 [234]	521 [236]

CONTINUED →

See Page 14 for Notes.

[] Designates Metric Conversions



NOMINAL SIZES 2-4 TONS [7.0-14.0 kW]

Model RQPW- Series	B048JK10X
Cooling Performance	
Gross Cooling Capacity Btu [kW]	49,000 [14.36]
EER/SEER	11.5/14
Nominal CFM/AHRI Rated CFM [L/s]	1600/1600 [755/755]
AHRI Net Cooling Capacity Btu [kW]	47,500 [13.92]
Net Sensible Capacity Btu [kW]	36,000 [10.55]
Net Latent Capacity Btu [kW]	11,500 [3.37]
Net System Power kW	4.13
Heating Performance (Heat Pumps)	
High Temp. Btuh [kW] Rating	46,000 [13.48]
System Power KW / COP	3.89/3.44
Low Temp. Btuh [kW] Rating	26,600 [7.79]
System Power KW / COP	3.57/2.2
HSPF (Btu/Watts-hr)	8
Heating Performance (Package Gas/Electric)	
Heating Input Btu [kW]	100,000 [29.3]
Heating Output Btu [kW]	77,000 [22.56]
Temperature Rise Range Δ F [Δ C]	45-85 [25/47.2]
AFUE (%)	80
Steady State Efficiency (%)	81
No. Burners	5
No. Stages	1
Gas Connection Pipe Size in. [mm]	0.5 [12.7]
Compressor	
No./Type	1/Scroll
Outdoor Sound Rating (dB)	78
Outdoor Coil Fin Type	
Tube Type	Rifled
Tube Size in. [mm] OD	0.375 [9.5]
Face Area sq. ft. [sq. m]	16.32 [1.52]
Rows / FPI [FPcm]	2 / 22 [9]
Refrigerant Control	TX Valves
Indoor Coil Fin Type	
Tube Type	Rifled
Tube Size in. [mm]	0.375 [9.5]
Face Area sq. ft. [sq. m]	7.39 [0.69]
Rows / FPI [FPcm]	2 / 15 [6]
Refrigerant Control	TX Valves
Drain Connection No./Size in. [mm]	1/1 [25.4]
Outdoor Fan Type	
Type	Propeller
No. Used/Diameter in. [mm]	1/22 [558.8]
Drive Type/No. Speeds	Direct/1
CFM [L/s]	3000 [1416]
No. Motors/HP	1 at 1/3 HP
Motor RPM	1075
Indoor Fan Type	
Type	FC Centrifugal
No. Used/Diameter in. [mm]	1/10x9 [254x229]
Drive Type/No. Speeds	Direct/2
No. Motors	1
Motor HP	3/4
Motor RPM	1075
Motor Frame Size	48
Filter Type	
Type	Field Supplied
Furnished	No
(No.) Size Recommended in. [mm]	(1)1x24x24 [25x610x610]
Refrigerant Charge Oz. [g]	183 [5188]
Weights	
Net Weight lbs. [kg]	510 [231]
Ship Weight lbs. [kg]	521 [236]

See Page 14 for Notes.

[] Designates Metric Conversions





NOTES:

1. Cooling Performance is rated at 95° F ambient, 80° F entering dry bulb, 67° F entering wet bulb. Gross capacity does not include the effect of fan motor heat. AHRI capacity is net and includes the effect of fan motor heat. Units are suitable for operation to 20% of nominal cfm. Units are certified in accordance with the Unitary Air Conditioner Equipment certification program, which is based on AHRI Standard 210/240 or 360.
2. EER and/or SEER are rated at AHRI conditions and in accordance with DOE test procedures.
3. Heating Performance is rated at 47° F ambient, 70° F entering dry bulb for High Temp rating and 17° F ambient, 70° F entering dry bulb for Low Temp rating. Performance ratings do include the effect of fan motor heat. Heating Performance limit settings and rating data were established and approved under laboratory test conditions using American National Standard Institute standards. Ratings shown are for elevations up to 2000 feet. For elevations above 2000 feet, ratings should be reduced at the rate of 4% for each 1000 feet above sea level.
4. AFUE is rated in accordance with DOE test procedures.
5. Outdoor Sound Rating shown is tested in accordance with AHRI Standard 270.



COOLING PERFORMANCE DATA—RQPW-024

		ENTERING INDOOR AIR @ 80°F [26.7°C] dbE									
		wbE	71°F [21.7°C]			67°F [19.4°C]			63°F [17.2°C]		
		CFM [L/s]	940 [444]	850 [401]	760 [359]	940 [444]	850 [401]	760 [359]	940 [444]	850 [401]	760 [359]
		DR	.15	.13	.11	.15	.13	.11	.15	.13	.11
OUTDOOR DRY BULB TEMPERATURE °F [°C]	75 [23.9]	Total BTUH [kW] Sens BTUH [kW] Power	29.9 [8.76] 19.2 [5.63] 1.5	29.4 [8.62] 18.4 [5.39] 1.5	28.8 [8.44] 17.5 [5.13] 1.5	28.6 [8.38] 22.0 [6.45] 1.5	28.0 [8.21] 21.0 [6.15] 1.5	27.5 [8.06] 20.1 [5.89] 1.5	27.6 [8.09] 23.3 [6.83] 1.5	27.1 [7.94] 22.3 [6.54] 1.5	26.6 [7.80] 21.2 [6.21] 1.5
	80 [26.7]	Total BTUH [kW] Sens BTUH [kW] Power	29.7 [8.70] 19.0 [5.57] 1.6	29.1 [8.53] 18.1 [5.30] 1.6	28.6 [8.38] 17.3 [5.07] 1.6	28.3 [8.29] 21.8 [6.39] 1.6	27.8 [8.15] 20.8 [6.10] 1.6	27.3 [8.00] 19.9 [5.83] 1.6	27.3 [8.00] 23.1 [6.77] 1.6	26.8 [7.85] 22.1 [6.48] 1.6	26.4 [7.74] 21.0 [6.15] 1.6
	85 [29.4]	Total BTUH [kW] Sens BTUH [kW] Power	29.0 [8.50] 18.6 [5.45] 1.7	28.5 [8.35] 17.8 [5.22] 1.7	27.9 [8.18] 16.9 [4.95] 1.7	27.6 [8.07] 21.4 [6.27] 1.7	27.2 [7.97] 20.5 [6.01] 1.7	26.7 [7.83] 19.5 [5.71] 1.7	26.7 [7.83] 22.7 [6.65] 1.7	26.2 [7.68] 21.7 [6.36] 1.7	25.7 [7.53] 20.7 [6.07] 1.7
	90 [32.2]	Total BTUH [kW] Sens BTUH [kW] Power	28.0 [8.21] 18.1 [5.30] 1.8	27.5 [8.06] 17.3 [5.07] 1.8	27.0 [7.91] 16.5 [4.84] 1.8	26.6 [7.80] 20.9 [6.13] 1.8	26.2 [7.68] 20.0 [5.86] 1.8	25.7 [7.53] 19.1 [5.60] 1.8	25.6 [7.50] 22.2 [6.51] 1.8	25.2 [7.39] 21.2 [6.21] 1.8	24.7 [7.24] 20.2 [5.92] 1.8
	95 [35]	Total BTUH [kW] Sens BTUH [kW] Power	26.7 [7.83] 17.5 [5.13] 1.9	26.3 [7.71] 16.7 [4.89] 1.9	25.8 [7.56] 16.0 [4.69] 1.9	25.4 [7.44] 20.4 [5.98] 1.9	24.9 [7.30] 19.4 [5.69] 1.9	24.5 [7.18] 18.5 [5.42] 1.9	24.4 [7.15] 21.6 [6.33] 1.9	24.0 [7.03] 20.7 [6.07] 1.9	23.5 [6.89] 19.7 [5.77] 1.9
	100 [37.8]	Total BTUH [kW] Sens BTUH [kW] Power	25.4 [7.44] 16.9 [4.95] 2.0	24.9 [7.30] 16.1 [4.72] 2.0	24.5 [7.18] 15.4 [4.51] 2.0	24.0 [7.03] 19.7 [5.77] 2.0	23.6 [6.92] 18.8 [5.51] 2.0	23.2 [6.80] 18.0 [5.28] 2.0	23.0 [6.74] 21.0 [6.15] 2.0	22.6 [6.62] 20.1 [5.89] 2.0	22.2 [6.51] 19.1 [5.60] 2.0
	105 [40.6]	Total BTUH [kW] Sens BTUH [kW] Power	24.0 [7.03] 16.3 [4.78] 2.1	23.6 [6.92] 15.5 [4.54] 2.1	23.1 [6.77] 14.8 [4.34] 2.1	22.6 [6.62] 19.1 [5.60] 2.1	22.2 [6.51] 18.2 [5.33] 2.1	21.8 [6.39] 17.4 [5.10] 2.1	21.7 [6.36] 20.4 [5.98] 2.1	21.3 [6.24] 19.5 [5.71] 2.1	20.9 [6.13] 18.5 [5.42] 2.1
	110 [43.3]	Total BTUH [kW] Sens BTUH [kW] Power	22.7 [6.65] 15.6 [4.57] 2.2	22.3 [6.54] 14.9 [4.37] 2.2	21.9 [6.42] 14.2 [4.16] 2.2	21.4 [6.27] 18.5 [5.42] 2.2	21.0 [6.15] 17.6 [5.16] 2.2	20.6 [6.04] 16.8 [4.92] 2.2	20.4 [5.98] 19.7 [5.77] 2.2	20.0 [5.86] 18.9 [5.54] 2.2	19.6 [5.74] 18.0 [5.28] 2.2
	115 [46.1]	Total BTUH [kW] Sens BTUH [kW] Power	21.6 [6.33] 15.1 [4.43] 2.3	21.2 [6.21] 14.4 [4.22] 2.3	20.8 [6.10] 13.7 [4.02] 2.3	20.2 [5.92] 17.9 [5.25] 2.3	19.9 [5.83] 17.1 [5.01] 2.3	19.5 [5.71] 16.3 [4.78] 2.3	19.3 [5.66] 19.2 [5.63] 2.3	18.9 [5.54] 18.3 [5.36] 2.3	18.6 [5.45] 17.5 [5.13] 2.3

DR —Depression ratio
dbE—Entering air dry bulb
wbE—Entering air wet bulb

Total —Total capacity x 1000 BTUH
Sens —Sensible capacity x 1000 BTUH
Power—KW input

NOTES:
When the entering air dry bulb is other than 80°F [27°C], adjust the sensible capacity from the table by adding [1.10 x CFM x (1 – DR) x (dbE – 80)].

HEATING PERFORMANCE DATA—RQPW-024

		IDB	60°F [15.5°C]			70°F [21.1°C]			80°F [26.7°C]		
		CFM [L/s]	940 [444]	850 [401]	760 [359]	940 [444]	850 [401]	760 [359]	940 [444]	850 [401]	760 [359]
OUTDOOR DRY BULB TEMPERATURE °F [°C]	0 [-17.8]	Total BTUH [kW] Power	8.9 [2.61] 1.4	8.8 [2.58] 1.4	8.7 [2.55] 1.4	8.0 [2.34] 1.6	7.9 [2.32] 1.6	7.9 [2.32] 1.6	6.5 [1.90] 1.8	6.5 [1.90] 1.8	6.4 [1.88] 1.9
	5 [-15]	Total BTUH [kW] Power	10.5 [3.08] 1.4	10.4 [3.05] 1.4	10.3 [3.02] 1.5	9.6 [2.81] 1.6	9.5 [2.78] 1.6	9.5 [2.78] 1.6	8.2 [2.40] 1.8	8.1 [2.37] 1.9	8.1 [2.37] 1.9
	10 [-12.2]	Total BTUH [kW] Power	12.1 [3.55] 1.4	12.0 [3.52] 1.5	12.0 [3.52] 1.5	11.2 [3.28] 1.6	11.2 [3.28] 1.6	11.1 [3.25] 1.7	9.8 [2.87] 1.9	9.7 [2.84] 1.9	9.7 [2.84] 1.9
	15 [-9.4]	Total BTUH [kW] Power	13.8 [4.04] 1.5	13.7 [4.02] 1.5	13.6 [3.99] 1.5	12.9 [3.78] 1.6	12.8 [3.75] 1.7	12.7 [3.72] 1.7	11.4 [3.34] 1.9	11.4 [3.34] 1.9	11.3 [3.31] 1.9
	20 [-6.7]	Total BTUH [kW] Power	15.4 [4.51] 1.5	15.3 [4.48] 1.5	15.2 [4.45] 1.5	14.5 [4.25] 1.7	14.4 [4.22] 1.7	14.3 [4.19] 1.7	13.1 [3.84] 1.9	13.0 [3.81] 1.9	12.9 [3.78] 1.9
	25 [-3.9]	Total BTUH [kW] Power	17.0 [4.98] 1.5	16.9 [4.95] 1.5	16.8 [4.92] 1.5	16.1 [4.72] 1.7	16.0 [4.69] 1.7	15.9 [4.66] 1.7	14.7 [4.31] 1.9	14.6 [4.28] 1.9	14.5 [4.25] 2.0
	30 [-1.1]	Total BTUH [kW] Power	18.7 [5.48] 1.5	18.5 [5.42] 1.5	18.4 [5.39] 1.6	17.8 [5.22] 1.7	17.6 [5.16] 1.7	17.5 [5.13] 1.7	16.3 [4.78] 1.9	16.2 [4.75] 2.0	16.1 [4.72] 2.0
	35 [1.7]	Total BTUH [kW] Power	20.3 [5.95] 1.5	20.1 [5.89] 1.6	20.0 [5.86] 1.6	19.4 [5.69] 1.7	19.3 [5.66] 1.7	19.1 [5.60] 1.8	18.0 [5.28] 2.0	17.8 [5.22] 2.0	17.7 [5.19] 2.0
	40 [4.4]	Total BTUH [kW] Power	21.9 [6.42] 1.6	21.8 [6.39] 1.6	21.6 [6.33] 1.6	21.0 [6.15] 1.7	20.9 [6.13] 1.8	20.7 [6.07] 1.8	19.6 [5.74] 2.0	19.5 [5.71] 2.0	19.3 [5.66] 2.0
	45 [7.2]	Total BTUH [kW] Power	23.6 [6.92] 1.6	23.4 [6.86] 1.6	23.2 [6.80] 1.6	22.7 [6.65] 1.8	22.5 [6.59] 1.8	22.3 [6.54] 1.8	21.2 [6.21] 2.0	21.1 [6.18] 2.0	20.9 [6.13] 2.1
50 [10]	Total BTUH [kW] Power	25.2 [7.39] 1.6	25.0 [7.33] 1.6	24.8 [7.27] 1.6	24.3 [7.12] 1.8	24.1 [7.06] 1.8	24.0 [7.03] 1.8	22.9 [6.71] 2.0	22.7 [6.65] 2.0	22.5 [6.59] 2.1	

IDB—Indoor air dry bulb

[] Designates Metric Conversions





COOLING PERFORMANCE DATA—RQPW-025

ENTERING INDOOR AIR @ 80°F [26.7°C] dbE											
wbE			71°F [21.7°C]			67°F [19.4°C]			63°F [17.2°C]		
CFM [L/s]			930 [439]	850 [401]	760 [359]	930 [439]	850 [401]	760 [359]	930 [439]	850 [401]	760 [359]
DR			.15	.17	.19	.15	.17	.19	.15	.17	.19
OUTDOOR DRY BULB TEMPERATURE °F [°C]	75 [23.9]	Total BTUH [kW]	29.4 [8.6]	28.9 [8.5]	28.3 [8.3]	28.0 [8.2]	27.6 [8.1]	27.0 [7.9]	26.6 [7.8]	26.2 [7.7]	25.7 [7.5]
		Sens BTUH [kW]	18.9 [5.5]	17.6 [5.2]	16.2 [4.8]	21.3 [6.3]	20.0 [5.9]	18.4 [5.4]	23.4 [6.9]	22.0 [6.5]	20.4 [6.0]
		Power	1.4	1.4	1.4	1.4	1.4	1.4	1.4	1.4	1.4
	80 [26.7]	Total BTUH [kW]	28.8 [8.4]	28.3 [8.3]	27.7 [8.1]	27.4 [8.0]	26.9 [7.9]	26.4 [7.7]	26.0 [7.6]	25.5 [7.5]	25.1 [7.4]
		Sens BTUH [kW]	18.6 [5.5]	17.3 [5.1]	15.9 [4.7]	21.0 [6.2]	19.6 [5.8]	18.2 [5.3]	23.0 [6.8]	21.5 [6.3]	20.1 [5.9]
		Power	1.5	1.5	1.5	1.5	1.5	1.5	1.5	1.5	1.5
	85 [29.4]	Total BTUH [kW]	28.0 [8.2]	27.5 [8.1]	27.0 [7.9]	26.7 [7.8]	26.2 [7.7]	25.7 [7.5]	25.2 [7.4]	24.8 [7.3]	24.3 [7.1]
		Sens BTUH [kW]	18.2 [5.3]	16.9 [5.0]	15.6 [4.6]	20.7 [6.1]	19.3 [5.7]	17.9 [5.3]	22.5 [6.6]	21.2 [6.2]	19.7 [5.8]
		Power	1.6	1.6	1.6	1.6	1.6	1.6	1.6	1.6	1.6
90 [32.2]	Total BTUH [kW]	27.1 [7.9]	26.7 [7.8]	26.2 [7.7]	25.8 [7.6]	25.3 [7.4]	24.9 [7.3]	24.4 [7.2]	23.9 [7.0]	23.5 [6.9]	
	Sens BTUH [kW]	17.6 [5.2]	16.5 [4.8]	15.2 [4.5]	20.1 [5.9]	18.8 [5.5]	17.5 [5.1]	22.1 [6.5]	20.7 [6.1]	19.3 [5.7]	
	Power	1.7	1.7	1.7	1.7	1.7	1.7	1.7	1.7	1.7	
95 [35]	Total BTUH [kW]	26.1 [7.6]	25.7 [7.5]	25.2 [7.4]	24.8 [7.3]	24.4 [7.2]	23.9 [7.0]	23.4 [6.9]	23.0 [6.7]	22.5 [6.6]	
	Sens BTUH [kW]	17.1 [5.0]	16.0 [4.7]	14.7 [4.3]	19.6 [5.8]	18.4 [5.4]	17.0 [5.0]	21.6 [6.3]	20.3 [6.0]	18.8 [5.5]	
	Power	1.8	1.8	1.8	1.8	1.8	1.8	1.8	1.8	1.8	
100 [37.8]	Total BTUH [kW]	25.0 [7.3]	24.6 [7.2]	24.1 [7.1]	23.7 [6.9]	23.3 [6.8]	22.8 [6.7]	22.2 [6.5]	21.9 [6.4]	21.4 [6.3]	
	Sens BTUH [kW]	16.6 [4.9]	15.5 [4.6]	14.3 [4.2]	19.1 [5.6]	17.9 [5.3]	16.5 [4.8]	21.0 [6.2]	19.8 [5.8]	18.3 [5.4]	
	Power	2.0	1.9	1.9	2.0	1.9	1.9	1.9	1.9	1.9	
105 [40.6]	Total BTUH [kW]	23.8 [7.0]	23.4 [6.9]	22.9 [6.7]	22.4 [6.6]	22.0 [6.4]	21.6 [6.3]	21.0 [6.2]	20.6 [6.0]	20.2 [5.9]	
	Sens BTUH [kW]	16.0 [4.7]	14.9 [4.4]	13.7 [4.0]	18.4 [5.4]	17.2 [5.1]	16.0 [4.7]	20.4 [6.0]	19.1 [5.6]	17.8 [5.2]	
	Power	2.1	2.1	2.0	2.1	2.1	2.0	2.1	2.1	2.0	
110 [43.3]	Total BTUH [kW]	22.4 [6.6]	22.0 [6.4]	21.6 [6.3]	21.0 [6.2]	20.7 [6.1]	20.3 [5.9]	19.6 [5.7]	19.3 [5.7]	18.9 [5.5]	
	Sens BTUH [kW]	15.3 [4.5]	14.3 [4.2]	13.2 [3.9]	17.7 [5.2]	16.7 [4.9]	15.5 [4.6]	19.6 [5.8]	18.6 [5.5]	17.3 [5.1]	
	Power	2.2	2.2	2.2	2.2	2.2	2.2	2.2	2.2	2.2	
115 [46.1]	Total BTUH [kW]	20.9 [6.1]	20.6 [6.0]	20.2 [5.9]	19.5 [5.7]	19.2 [5.6]	18.8 [5.5]	18.1 [5.3]	17.8 [5.2]	17.5 [5.1]	
	Sens BTUH [kW]	14.6 [4.3]	13.7 [4.0]	12.6 [3.7]	17.0 [5.0]	16.0 [4.7]	14.8 [4.3]	18.1 [5.3]	17.8 [5.2]	16.7 [4.9]	
	Power	2.4	2.3	2.3	2.3	2.3	2.3	2.3	2.3	2.3	

DR —Depression ratio
dbE—Entering air dry bulb
wbE—Entering air wet bulb

Total —Total capacity x 1000 BTUH
Sens —Sensible capacity x 1000 BTUH
Power —KW input

NOTES:
When the entering air dry bulb is other than 80°F [27°C], adjust the sensible capacity from the table by adding $[1.10 \times \text{CFM} \times (1 - \text{DR}) \times (\text{dbE} - 80)]$.

HEATING PERFORMANCE DATA—RQPW-025

IDB											
CFM [L/s]			60°F [15.5°C]			70°F [21.1°C]			80°F [26.7°C]		
			930 [439]	850 [401]	760 [359]	930 [439]	850 [401]	760 [359]	930 [439]	850 [401]	760 [359]
OUTDOOR DRY BULB TEMPERATURE °F [°C]	0 [-17.8]	Total BTUH [kW]	9.0 [2.6]	9.0 [2.6]	8.9 [2.6]	7.9 [2.3]	7.8 [2.3]	7.8 [2.3]	6.7 [2.0]	6.7 [2.0]	6.6 [1.9]
		Power	1.3	1.3	1.4	1.5	1.5	1.5	1.7	1.8	1.8
	5 [-15]	Total BTUH [kW]	10.7 [3.1]	10.6 [3.1]	10.5 [3.1]	9.5 [2.8]	9.4 [2.8]	9.4 [2.8]	8.3 [2.4]	8.3 [2.4]	8.2 [2.4]
		Power	1.3	1.4	1.4	1.5	1.5	1.6	1.8	1.8	1.8
	10 [-12.2]	Total BTUH [kW]	12.3 [3.6]	12.2 [3.6]	12.1 [3.5]	11.1 [3.3]	11.1 [3.3]	11.0 [3.2]	10.0 [2.9]	9.9 [2.9]	9.8 [2.9]
		Power	1.4	1.4	1.4	1.5	1.6	1.6	1.8	1.8	1.8
	15 [-9.4]	Total BTUH [kW]	13.9 [4.1]	13.8 [4.0]	13.7 [4.0]	12.8 [3.8]	12.7 [3.7]	12.6 [3.7]	11.6 [3.4]	11.5 [3.4]	11.4 [3.3]
		Power	1.4	1.4	1.4	1.6	1.6	1.6	1.8	1.8	1.9
	20 [-6.7]	Total BTUH [kW]	15.6 [4.6]	15.5 [4.5]	15.3 [4.5]	14.4 [4.2]	14.3 [4.2]	14.2 [4.2]	13.2 [3.9]	13.1 [3.8]	13.0 [3.8]
		Power	1.4	1.4	1.4	1.6	1.6	1.6	1.8	1.9	1.9
25 [-3.9]	Total BTUH [kW]	17.2 [5.0]	17.1 [5.0]	16.9 [5.0]	16.0 [4.7]	15.9 [4.7]	15.8 [4.6]	14.9 [4.4]	14.8 [4.3]	14.7 [4.3]	
	Power	1.4	1.4	1.5	1.6	1.6	1.6	1.8	1.9	1.9	
30 [-1.1]	Total BTUH [kW]	18.8 [5.5]	18.7 [5.5]	18.5 [5.4]	17.7 [5.2]	17.5 [5.1]	17.4 [5.1]	16.5 [4.8]	16.4 [4.8]	16.3 [4.8]	
	Power	1.4	1.5	1.5	1.6	1.6	1.7	1.9	1.9	1.9	
35 [1.7]	Total BTUH [kW]	20.4 [6.0]	20.3 [5.9]	20.2 [5.9]	19.3 [5.7]	19.2 [5.6]	19.0 [5.6]	18.1 [5.3]	18.0 [5.3]	17.9 [5.2]	
	Power	1.5	1.5	1.5	1.6	1.7	1.7	1.9	1.9	1.9	
40 [4.4]	Total BTUH [kW]	22.1 [6.5]	21.9 [6.4]	21.8 [6.4]	20.9 [6.1]	20.8 [6.1]	20.6 [6.0]	19.7 [5.8]	19.6 [5.7]	19.5 [5.7]	
	Power	1.5	1.5	1.5	1.7	1.7	1.7	1.9	1.9	2.0	
45 [7.2]	Total BTUH [kW]	23.7 [6.9]	23.5 [6.9]	23.4 [6.9]	22.5 [6.6]	22.4 [6.6]	22.2 [6.5]	21.4 [6.3]	21.2 [6.2]	21.1 [6.2]	
	Power	1.5	1.5	1.5	1.7	1.7	1.7	1.9	2.0	2.0	
50 [10]	Total BTUH [kW]	25.3 [7.4]	25.2 [7.4]	25.0 [7.3]	24.2 [7.1]	24.0 [7.0]	23.8 [7.0]	23.0 [6.7]	22.9 [6.7]	22.7 [6.7]	
	Power	1.5	1.5	1.6	1.7	1.7	1.7	1.9	2.0	2.0	

IDB—Indoor air dry bulb

[] Designates Metric Conversions





COOLING PERFORMANCE DATA—RQPW-030

ENTERING INDOOR AIR @ 80°F [26.7°C] dbE											
wbE			71°F [21.7°C]			67°F [19.4°C]			63°F [17.2°C]		
CFM [L/s]			1160 [547]	1050 [496]	940 [444]	1160 [547]	1050 [496]	940 [444]	1160 [547]	1050 [496]	940 [444]
DR			.15	.13	.11	.15	.13	.11	.15	.13	.11
OUTDOOR DRY BULB TEMPERATURE °F [°C]	75 [23.9]	Total BTUH [kW]	36.9 [10.81]	36.2 [10.61]	35.5 [10.40]	34.9 [10.23]	34.2 [10.02]	33.6 [9.85]	33.5 [9.82]	32.9 [9.64]	32.3 [9.47]
		Sens BTUH [kW]	23.7 [6.95]	22.6 [6.62]	21.5 [6.30]	26.9 [7.88]	25.7 [7.53]	24.5 [7.18]	28.4 [8.32]	27.1 [7.94]	25.8 [7.56]
		Power	1.9	1.9	1.9	1.9	1.9	1.9	1.9	1.9	1.9
	80 [26.7]	Total BTUH [kW]	35.7 [10.46]	35.1 [10.29]	34.4 [10.08]	33.7 [9.88]	33.1 [9.70]	32.5 [9.52]	32.3 [9.47]	31.8 [9.32]	31.2 [9.14]
		Sens BTUH [kW]	23.1 [6.77]	22.0 [6.45]	21.0 [6.15]	26.3 [7.71]	25.2 [7.39]	24.0 [7.03]	27.8 [8.15]	26.5 [7.77]	25.3 [7.41]
		Power	2.0	2.0	2.0	2.0	2.0	2.0	2.0	2.0	2.0
	85 [29.4]	Total BTUH [kW]	34.6 [10.14]	33.9 [9.94]	33.3 [9.76]	32.6 [9.55]	32.0 [9.38]	31.4 [9.20]	31.2 [9.14]	30.6 [8.97]	30.1 [8.82]
		Sens BTUH [kW]	22.5 [6.59]	21.5 [6.30]	20.5 [6.01]	25.8 [7.56]	24.6 [7.21]	23.5 [6.89]	27.2 [7.97]	26.0 [7.62]	24.8 [7.27]
		Power	2.1	2.1	2.1	2.1	2.1	2.1	2.1	2.1	2.1
	90 [32.2]	Total BTUH [kW]	33.4 [9.79]	32.8 [9.61]	32.2 [9.44]	31.4 [9.20]	30.9 [9.06]	30.3 [8.88]	30.1 [8.82]	29.5 [8.65]	29.0 [8.50]
Sens BTUH [kW]		21.9 [6.42]	20.9 [6.13]	20.0 [5.86]	25.2 [7.39]	24.1 [7.06]	23.0 [6.74]	26.6 [7.80]	25.4 [7.44]	24.3 [7.12]	
Power		2.2	2.2	2.2	2.2	2.2	2.2	2.2	2.2	2.2	
95 [35]	Total BTUH [kW]	32.3 [9.47]	31.7 [9.29]	31.1 [9.11]	30.3 [8.88]	29.8 [8.73]	29.2 [8.56]	28.9 [8.47]	28.4 [8.32]	27.9 [8.18]	
	Sens BTUH [kW]	21.4 [6.27]	20.4 [5.98]	19.5 [5.71]	24.7 [7.24]	23.6 [6.92]	22.5 [6.59]	26.1 [7.65]	24.9 [7.30]	23.8 [6.98]	
	Power	2.3	2.3	2.3	2.3	2.3	2.2	2.3	2.3	2.3	
100 [37.8]	Total BTUH [kW]	31.1 [9.11]	30.6 [8.97]	30.0 [8.79]	29.1 [8.53]	28.6 [8.38]	28.1 [8.24]	27.8 [8.15]	27.3 [8.00]	26.8 [7.85]	
	Sens BTUH [kW]	20.8 [6.10]	19.9 [5.83]	19.0 [5.57]	24.1 [7.06]	23.0 [6.74]	22.0 [6.45]	25.5 [7.47]	24.4 [7.15]	23.3 [6.83]	
	Power	2.4	2.4	2.4	2.4	2.4	2.3	2.4	2.4	2.4	
105 [40.6]	Total BTUH [kW]	30.0 [8.79]	29.4 [8.62]	28.9 [8.47]	28.0 [8.21]	27.5 [8.06]	27.0 [7.91]	26.6 [7.80]	26.1 [7.65]	25.6 [7.50]	
	Sens BTUH [kW]	20.3 [5.95]	19.4 [5.69]	18.5 [5.42]	23.6 [6.92]	22.5 [6.59]	21.5 [6.30]	25.0 [7.33]	23.9 [7.00]	22.8 [6.68]	
	Power	2.5	2.5	2.5	2.5	2.5	2.4	2.5	2.5	2.5	
110 [43.3]	Total BTUH [kW]	28.7 [8.41]	28.2 [8.26]	27.7 [8.12]	26.7 [7.83]	26.2 [7.68]	25.8 [7.56]	25.4 [7.44]	24.9 [7.30]	24.5 [7.18]	
	Sens BTUH [kW]	19.7 [5.77]	18.8 [5.51]	18.0 [5.28]	23.0 [6.74]	22.0 [6.45]	21.0 [6.15]	24.4 [7.15]	23.4 [6.86]	22.3 [6.54]	
	Power	2.6	2.6	2.6	2.6	2.6	2.5	2.6	2.6	2.6	
115 [46.1]	Total BTUH [kW]	27.4 [8.03]	26.9 [7.88]	26.4 [7.74]	25.4 [7.44]	25.0 [7.33]	24.5 [7.18]	24.1 [7.06]	23.6 [6.92]	23.2 [6.80]	
	Sens BTUH [kW]	19.2 [5.63]	18.3 [5.36]	17.5 [5.13]	22.5 [6.59]	21.5 [6.30]	20.5 [6.01]	23.9 [7.00]	22.8 [6.68]	21.8 [6.39]	
	Power	2.7	2.7	2.7	2.7	2.6	2.6	2.7	2.7	2.7	

DR —Depression ratio
dbE—Entering air dry bulb
wbE—Entering air wet bulb

Total —Total capacity x 1000 BTUH
Sens —Sensible capacity x 1000 BTUH
Power—KW input

NOTES:
When the entering air dry bulb is other than 80°F [27°C], adjust the sensible capacity from the table by adding [1.10 x CFM x (1 – DR) x (dbE – 80)].

HEATING PERFORMANCE DATA—RQPW-030

IDB											
CFM [L/s]			60°F [15.5°C]			70°F [21.1°C]			80°F [26.7°C]		
			1160 [547]	1050 [496]	940 [444]	1160 [547]	1050 [496]	940 [444]	1160 [547]	1050 [496]	940 [444]
OUTDOOR DRY BULB TEMPERATURE °F [°C]	0 [-17.8]	Total BTUH [kW]	9.5 [2.78]	9.5 [2.78]	9.4 [2.75]	8.0 [2.34]	7.9 [2.32]	7.9 [2.32]	6.6 [1.93]	6.5 [1.90]	6.5 [1.90]
		Power	1.6	1.6	1.6	1.8	1.8	1.8	2.0	2.0	2.1
	5 [-15]	Total BTUH [kW]	11.5 [3.37]	11.4 [3.34]	11.3 [3.31]	9.9 [2.90]	9.8 [2.87]	9.8 [2.87]	8.5 [2.49]	8.4 [2.46]	8.4 [2.46]
		Power	1.6	1.6	1.6	1.8	1.8	1.9	2.0	2.1	2.1
	10 [12.2]	Total BTUH [kW]	13.4 [3.93]	13.3 [3.90]	13.2 [3.87]	11.8 [3.46]	11.8 [3.46]	11.7 [3.43]	10.4 [3.05]	10.3 [3.02]	10.3 [3.02]
		Power	1.6	1.7	1.7	1.9	1.9	1.9	2.1	2.1	2.1
	15 [-9.4]	Total BTUH [kW]	15.3 [4.48]	15.2 [4.45]	15.1 [4.43]	13.8 [4.04]	13.7 [4.02]	13.6 [3.99]	12.3 [3.60]	12.3 [3.60]	12.2 [3.58]
		Power	1.7	1.7	1.7	1.9	1.9	1.9	2.1	2.1	2.2
	20 [-6.7]	Total BTUH [kW]	17.2 [5.04]	17.1 [5.01]	17.0 [4.98]	15.7 [4.60]	15.6 [4.57]	15.5 [4.54]	14.3 [4.19]	14.2 [4.16]	14.1 [4.13]
		Power	1.7	1.7	1.7	1.9	1.9	2.0	2.1	2.2	2.2
25 [-3.9]	Total BTUH [kW]	19.2 [5.63]	19.0 [5.57]	18.9 [5.54]	17.6 [5.16]	17.5 [5.13]	17.4 [5.10]	16.2 [4.75]	16.1 [4.72]	16.0 [4.69]	
	Power	1.7	1.8	1.8	1.9	2.0	2.0	2.2	2.2	2.2	
30 [-1.1]	Total BTUH [kW]	21.1 [6.18]	20.9 [6.13]	20.8 [6.10]	19.5 [5.71]	19.4 [5.69]	19.3 [5.66]	18.1 [5.30]	18.0 [5.28]	17.9 [5.25]	
	Power	1.8	1.8	1.8	2.0	2.0	2.0	2.2	2.2	2.3	
35 [1.7]	Total BTUH [kW]	23.0 [6.74]	22.8 [6.68]	22.7 [6.65]	21.5 [6.30]	21.3 [6.24]	21.2 [6.21]	20.0 [5.86]	19.9 [5.83]	19.7 [5.77]	
	Power	1.8	1.8	1.8	2.0	2.0	2.1	2.2	2.3	2.3	
40 [4.4]	Total BTUH [kW]	24.9 [7.30]	24.8 [7.27]	24.6 [7.21]	23.4 [6.86]	23.2 [6.80]	23.0 [6.74]	22.0 [6.45]	21.8 [6.39]	21.6 [6.33]	
	Power	1.8	1.8	1.9	2.0	2.1	2.1	2.3	2.3	2.3	
45 [7.2]	Total BTUH [kW]	26.9 [7.88]	26.7 [7.83]	26.5 [7.77]	25.3 [7.41]	25.1 [7.36]	24.9 [7.30]	23.9 [7.00]	23.7 [6.95]	23.5 [6.89]	
	Power	1.9	1.9	1.9	2.1	2.1	2.1	2.3	2.3	2.4	
50 [10]	Total BTUH [kW]	28.8 [8.44]	28.6 [8.38]	28.4 [8.32]	27.2 [7.97]	27.0 [7.91]	26.8 [7.85]	25.8 [7.56]	25.6 [7.50]	25.4 [7.44]	
	Power	1.9	1.9	1.9	2.1	2.1	2.2	2.3	2.4	2.4	

IDB—Indoor air dry bulb

[] Designates Metric Conversions





COOLING PERFORMANCE DATA—RQPW-036

		ENTERING INDOOR AIR @ 80°F [26.7°C] dbE									
		wbE	71°F [21.7°C]			67°F [19.4°C]			63°F [17.2°C]		
		CFM [L/s]	1380 [651]	1250 [590]	1120 [528]	1380 [651]	1250 [590]	1120 [528]	1380 [651]	1250 [590]	1120 [528]
		DR	.19	.18	.16	.19	.18	.16	.19	.18	.16
OUTDOOR DRY BULB TEMPERATURE °F [°C]	75 [23.9]	Total BTUH [kW] Sens BTUH [kW] Power	45.0 [13.19] 27.7 [8.12] 2.3	44.2 [12.95] 26.5 [7.77] 2.2	43.4 [12.72] 25.3 [7.41] 2.2	42.9 [12.57] 31.8 [9.32] 2.2	42.2 [12.37] 30.4 [8.91] 2.2	41.4 [12.13] 28.9 [8.47] 2.2	41.8 [12.25] 34.2 [10.02] 2.2	41.0 [12.02] 32.6 [9.55] 2.2	40.3 [11.81] 31.1 [9.11] 2.2
	80 [26.7]	Total BTUH [kW] Sens BTUH [kW] Power	43.9 [12.87] 27.1 [7.94] 2.4	43.1 [12.63] 25.9 [7.59] 2.4	42.3 [12.40] 24.7 [7.24] 2.4	41.8 [12.25] 31.2 [9.14] 2.4	41.1 [12.05] 29.8 [8.73] 2.4	40.3 [11.81] 28.4 [8.32] 2.3	40.7 [11.93] 33.5 [9.82] 2.4	39.9 [11.69] 32.0 [9.38] 2.3	39.2 [11.49] 30.5 [8.94] 2.3
	85 [29.4]	Total BTUH [kW] Sens BTUH [kW] Power	42.6 [12.48] 26.5 [7.77] 2.5	41.8 [12.25] 25.3 [7.41] 2.5	41.0 [12.02] 24.1 [7.06] 2.5	40.5 [11.87] 30.5 [8.94] 2.5	39.8 [11.66] 29.1 [8.53] 2.5	39.1 [11.46] 27.8 [8.15] 2.5	39.4 [11.55] 32.9 [9.64] 2.5	38.7 [11.34] 31.4 [9.20] 2.5	37.9 [11.11] 29.9 [8.76] 2.5
	90 [32.2]	Total BTUH [kW] Sens BTUH [kW] Power	41.1 [12.05] 25.7 [7.53] 2.7	40.3 [11.81] 24.6 [7.21] 2.7	39.6 [11.61] 23.5 [6.89] 2.6	39.0 [11.43] 29.8 [8.73] 2.7	38.3 [11.22] 28.5 [8.35] 2.6	37.6 [11.02] 27.1 [7.94] 2.6	37.9 [11.11] 32.2 [9.44] 2.6	37.2 [10.90] 30.7 [9.00] 2.6	36.5 [10.70] 29.3 [8.59] 2.6
	95 [35]	Total BTUH [kW] Sens BTUH [kW] Power	39.5 [11.58] 25.0 [7.33] 2.8	38.8 [11.37] 23.9 [7.00] 2.8	38.1 [11.17] 22.8 [6.68] 2.8	37.4 [10.96] 29.1 [8.53] 2.8	36.8 [10.79] 27.8 [8.15] 2.8	36.1 [10.58] 26.5 [7.77] 2.8	36.3 [10.64] 31.4 [9.20] 2.8	35.6 [10.43] 30.0 [8.79] 2.8	35.0 [10.26] 28.6 [8.38] 2.7
	100 [37.8]	Total BTUH [kW] Sens BTUH [kW] Power	37.8 [11.08] 24.2 [7.09] 3.0	37.1 [10.87] 23.2 [6.80] 2.9	36.5 [10.70] 22.1 [6.48] 2.9	35.8 [10.49] 28.3 [8.29] 2.9	35.1 [10.29] 27.0 [7.91] 2.9	34.5 [10.11] 25.8 [7.56] 2.9	34.6 [10.14] 30.7 [9.00] 2.9	34.0 [9.96] 29.3 [8.59] 2.9	33.4 [9.79] 27.9 [8.18] 2.9
	105 [40.6]	Total BTUH [kW] Sens BTUH [kW] Power	36.1 [10.58] 23.4 [6.86] 3.1	35.5 [10.40] 22.4 [6.56] 3.1	34.8 [10.20] 21.3 [6.24] 3.1	34.1 [9.99] 27.5 [8.06] 3.1	33.5 [9.82] 26.3 [7.71] 3.1	32.8 [9.61] 25.0 [7.33] 3.0	32.9 [9.64] 29.9 [8.76] 3.1	32.3 [9.47] 28.5 [8.35] 3.0	31.7 [9.29] 27.2 [7.97] 3.0
	110 [43.3]	Total BTUH [kW] Sens BTUH [kW] Power	34.4 [10.08] 22.6 [6.62] 3.3	33.8 [9.91] 21.6 [6.33] 3.2	33.2 [9.73] 20.6 [6.04] 3.2	32.4 [9.50] 26.7 [7.83] 3.2	31.8 [9.32] 25.5 [7.47] 3.2	31.2 [9.14] 24.3 [7.12] 3.2	31.2 [9.14] 29.0 [8.50] 3.2	30.7 [9.00] 27.7 [8.12] 3.2	30.1 [8.82] 26.4 [7.74] 3.2
	115 [46.1]	Total BTUH [kW] Sens BTUH [kW] Power	32.8 [9.61] 21.8 [6.39] 3.4	32.2 [9.44] 20.8 [6.10] 3.4	31.7 [9.29] 19.8 [5.80] 3.3	30.8 [9.03] 25.8 [7.56] 3.4	30.2 [8.85] 24.7 [7.24] 3.3	29.7 [8.70] 23.5 [6.89] 3.3	29.6 [8.67] 28.2 [8.26] 3.4	29.1 [8.53] 26.9 [7.88] 3.3	28.6 [8.38] 25.7 [7.53] 3.3

DR —Depression ratio
dbE —Entering air dry bulb
wbE —Entering air wet bulb

Total —Total capacity x 1000 BTUH
Sens —Sensible capacity x 1000 BTUH
Power —KW input

NOTES:
When the entering air dry bulb is other than 80°F [27°C], adjust the sensible capacity from the table by adding [1.10 x CFM x (1 - DR) x (dbE - 80)].

HEATING PERFORMANCE DATA—RQPW-036

		IDB	60°F [15.5°C]			70°F [21.1°C]			80°F [26.7°C]		
		CFM [L/s]	1380 [651]	1250 [590]	1120 [528]	1380 [651]	1250 [590]	1120 [528]	1380 [651]	1250 [590]	1120 [528]
OUTDOOR DRY BULB TEMPERATURE °F [°C]	0 [-17.8]	Total BTUH [kW] Power	11.7 [3.43] 1.8	11.6 [3.40] 1.9	11.5 [3.37] 1.9	9.6 [2.81] 2.1	9.6 [2.81] 2.1	9.5 [2.78] 2.1	8.3 [2.43] 2.4	8.2 [2.40] 2.4	8.1 [2.37] 2.4
	5 [-15]	Total BTUH [kW] Power	14.1 [4.13] 1.9	14.0 [4.10] 1.9	13.9 [4.07] 1.9	12.1 [3.55] 2.1	12.0 [3.52] 2.2	11.9 [3.49] 2.2	10.7 [3.14] 2.4	10.6 [3.11] 2.5	10.6 [3.11] 2.5
	10 [-12.2]	Total BTUH [kW] Power	16.6 [4.86] 1.9	16.5 [4.84] 1.9	16.3 [4.78] 2.0	14.5 [4.25] 2.2	14.4 [4.22] 2.2	14.3 [4.19] 2.2	13.2 [3.87] 2.5	13.1 [3.84] 2.5	13.0 [3.81] 2.5
	15 [-9.4]	Total BTUH [kW] Power	19.0 [5.57] 2.0	18.9 [5.54] 2.0	18.8 [5.51] 2.0	17.0 [4.98] 2.2	16.9 [4.95] 2.2	16.7 [4.89] 2.3	15.6 [4.57] 2.5	15.5 [4.54] 2.5	15.4 [4.51] 2.6
	20 [-6.7]	Total BTUH [kW] Power	21.5 [6.30] 2.0	21.3 [6.24] 2.0	21.2 [6.21] 2.1	19.4 [5.69] 2.3	19.3 [5.66] 2.3	19.2 [5.63] 2.3	18.1 [5.30] 2.5	17.9 [5.25] 2.6	17.8 [5.22] 2.6
	25 [-3.9]	Total BTUH [kW] Power	23.9 [7.00] 2.0	23.8 [6.98] 2.1	23.6 [6.92] 2.1	21.9 [6.42] 2.3	21.7 [6.36] 2.3	21.6 [6.33] 2.4	20.5 [6.01] 2.6	20.4 [5.98] 2.6	20.2 [5.92] 2.7
	30 [-1.1]	Total BTUH [kW] Power	26.4 [7.74] 2.1	26.2 [7.68] 2.1	26.0 [7.62] 2.1	24.3 [7.12] 2.3	24.2 [7.09] 2.4	24.0 [7.03] 2.4	23.0 [6.74] 2.6	22.8 [6.68] 2.7	22.6 [6.62] 2.7
	35 [1.7]	Total BTUH [kW] Power	28.8 [8.44] 2.1	28.6 [8.38] 2.1	28.4 [8.32] 2.2	26.8 [7.85] 2.4	26.6 [7.80] 2.4	26.4 [7.74] 2.4	25.4 [7.44] 2.7	25.2 [7.39] 2.7	25.1 [7.36] 2.7
	40 [4.4]	Total BTUH [kW] Power	31.3 [9.17] 2.2	31.1 [9.11] 2.2	30.8 [9.03] 2.2	29.2 [8.56] 2.4	29.0 [8.50] 2.4	28.8 [8.44] 2.5	27.9 [8.18] 2.7	27.7 [8.12] 2.7	27.5 [8.06] 2.8
	45 [7.2]	Total BTUH [kW] Power	33.7 [9.88] 2.2	33.5 [9.82] 2.2	33.3 [9.76] 2.3	31.7 [9.29] 2.5	31.5 [9.23] 2.5	31.3 [9.17] 2.5	30.3 [8.88] 2.8	30.1 [8.82] 2.8	29.9 [8.76] 2.8
50 [10]	Total BTUH [kW] Power	36.2 [10.61] 2.2	35.9 [10.52] 2.3	35.7 [10.46] 2.3	34.2 [10.02] 2.5	33.9 [9.94] 2.5	33.7 [9.88] 2.6	32.8 [9.61] 2.8	32.5 [9.52] 2.8	32.3 [9.47] 2.9	

IDB—Indoor air dry bulb

[] Designates Metric Conversions





COOLING PERFORMANCE DATA—RQPW-042

		ENTERING INDOOR AIR @ 80°F [26.7°C] dbE									
		wbE	71°F [21.7°C]			67°F [19.4°C]			63°F [17.2°C]		
		CFM [L/s]	1540 [727]	1400 [661]	1260 [595]	1540 [727]	1400 [661]	1260 [595]	1540 [727]	1400 [661]	1260 [595]
		DR	.17	.15	.14	.17	.15	.14	.17	.15	.14
OUTDOOR DRY BULB TEMPERATURE °F [°C]	75 [23.9]	Total BTUH [kW] Sens BTUH [kW] Power	53.9 [15.80] 32.2 [9.44] 2.9	52.9 [15.50] 30.7 [9.00] 2.9	51.9 [15.21] 29.3 [8.59] 2.9	50.9 [14.92] 37.1 [10.87] 2.9	50.0 [14.65] 35.5 [10.40] 2.9	49.1 [14.39] 33.8 [9.91] 2.9	48.1 [14.10] 39.3 [11.52] 2.9	47.3 [13.86] 37.5 [10.99] 2.9	46.4 [13.60] 35.8 [10.49] 2.9
	80 [26.7]	Total BTUH [kW] Sens BTUH [kW] Power	52.0 [15.24] 31.3 [9.17] 3.1	51.0 [14.95] 29.9 [8.76] 3.1	50.1 [14.68] 28.5 [8.35] 3.1	49.0 [14.36] 36.3 [10.64] 3.1	48.1 [14.10] 34.7 [10.17] 3.1	47.2 [13.83] 33.0 [9.67] 3.0	46.2 [13.54] 38.4 [11.25] 3.1	45.4 [13.31] 36.7 [10.76] 3.1	44.6 [13.07] 35.0 [10.26] 3.0
	85 [29.4]	Total BTUH [kW] Sens BTUH [kW] Power	50.3 [14.74] 30.5 [8.94] 3.3	49.4 [14.48] 29.2 [8.56] 3.2	48.5 [14.21] 27.8 [8.15] 3.2	47.3 [13.86] 35.5 [10.40] 3.3	46.5 [13.63] 33.9 [9.94] 3.2	45.6 [13.36] 32.3 [9.47] 3.2	44.6 [13.07] 37.6 [11.02] 3.2	43.8 [12.84] 35.9 [10.52] 3.2	43.0 [12.60] 34.3 [10.05] 3.2
	90 [32.2]	Total BTUH [kW] Sens BTUH [kW] Power	48.7 [14.27] 29.8 [8.73] 3.4	47.9 [14.04] 28.4 [8.32] 3.4	47.0 [13.77] 27.1 [7.94] 3.4	45.8 [13.42] 34.7 [10.17] 3.4	44.9 [13.16] 33.2 [9.73] 3.4	44.1 [12.92] 31.6 [9.26] 3.4	43.0 [12.60] 36.8 [10.79] 3.4	42.2 [12.37] 35.2 [10.32] 3.4	41.5 [12.16] 33.6 [9.85] 3.4
	95 [35]	Total BTUH [kW] Sens BTUH [kW] Power	47.2 [13.83] 29.0 [8.50] 3.6	46.4 [13.60] 27.7 [8.12] 3.6	45.5 [13.33] 26.4 [7.74] 3.5	44.2 [12.95] 34.0 [9.96] 3.6	43.4 [12.72] 32.4 [9.50] 3.6	42.7 [12.51] 30.9 [9.06] 3.5	41.5 [12.16] 36.1 [10.58] 3.6	40.7 [11.93] 34.5 [10.11] 3.6	40.0 [11.72] 32.9 [9.64] 3.5
	100 [37.8]	Total BTUH [kW] Sens BTUH [kW] Power	45.6 [13.36] 28.2 [8.26] 3.8	44.8 [13.13] 26.9 [7.88] 3.7	44.0 [12.90] 25.7 [7.53] 3.7	42.6 [12.48] 33.2 [9.73] 3.8	41.9 [12.28] 31.7 [9.29] 3.7	41.1 [12.05] 30.2 [8.85] 3.7	39.9 [11.69] 35.3 [10.35] 3.7	39.2 [11.49] 33.7 [9.88] 3.7	38.5 [11.28] 32.1 [9.41] 3.7
	105 [40.6]	Total BTUH [kW] Sens BTUH [kW] Power	43.8 [12.84] 27.4 [8.03] 3.9	43.0 [12.60] 26.1 [7.65] 3.9	42.3 [12.40] 24.9 [7.30] 3.9	40.8 [11.96] 32.3 [9.47] 3.9	40.1 [11.75] 30.9 [9.06] 3.9	39.4 [11.55] 29.4 [8.62] 3.9	38.1 [11.17] 34.4 [10.08] 3.9	37.4 [10.96] 32.9 [9.64] 3.9	36.7 [10.76] 31.4 [9.20] 3.9
	110 [43.3]	Total BTUH [kW] Sens BTUH [kW] Power	41.7 [12.22] 26.4 [7.74] 4.1	41.0 [12.02] 25.2 [7.39] 4.1	40.2 [11.78] 24.1 [7.06] 4.0	38.8 [11.37] 31.4 [9.20] 4.1	38.1 [11.17] 30.0 [8.79] 4.1	37.4 [10.96] 28.6 [8.38] 4.0	36.0 [10.55] 33.5 [9.82] 4.1	35.4 [10.37] 32.0 [9.38] 4.1	34.7 [10.17] 30.5 [8.94] 4.0
	115 [46.1]	Total BTUH [kW] Sens BTUH [kW] Power	39.3 [11.52] 25.4 [7.44] 4.3	38.6 [11.31] 24.2 [7.09] 4.2	37.9 [11.11] 23.1 [6.77] 4.2	36.3 [10.64] 30.3 [8.88] 4.3	35.6 [10.43] 29.0 [8.50] 4.2	35.0 [10.26] 27.6 [8.09] 4.2	33.5 [9.82] 32.4 [9.50] 4.3	32.9 [9.64] 31.0 [9.09] 4.2	32.3 [9.47] 29.5 [8.65] 4.2

DR —Depression ratio
dbE—Entering air dry bulb
wbE—Entering air wet bulb

Total —Total capacity x 1000 BTUH
Sens —Sensible capacity x 1000 BTUH
Power—KW input

NOTES:
When the entering air dry bulb is other than 80°F [27°C], adjust the sensible capacity from the table by adding [1.10 x CFM x (1 – DR) x (dbE – 80)].

HEATING PERFORMANCE DATA—RQPW-042

		IDB	60°F [15.5°C]			70°F [21.1°C]			80°F [26.7°C]		
		CFM [L/s]	1540 [727]	1400 [661]	1260 [595]	1540 [727]	1400 [661]	1260 [595]	1540 [727]	1400 [661]	1260 [595]
OUTDOOR DRY BULB TEMPERATURE °F [°C]	0 [-17.8]	Total BTUH [kW] Power	13.9 [4.07] 2.6	13.8 [4.04] 2.6	13.7 [4.02] 2.6	12.9 [3.78] 3.0	12.8 [3.75] 3.0	12.8 [3.75] 3.1	11.2 [3.28] 3.3	11.1 [3.25] 3.4	11.1 [3.25] 3.4
	5 [-15]	Total BTUH [kW] Power	16.9 [4.95] 2.6	16.8 [4.92] 2.6	16.7 [4.89] 2.7	16.0 [4.69] 3.0	15.8 [4.63] 3.1	15.7 [4.60] 3.1	14.2 [4.16] 3.4	14.1 [4.13] 3.4	14.0 [4.10] 3.5
	10 [-12.2]	Total BTUH [kW] Power	20.0 [5.86] 2.6	19.8 [5.80] 2.7	19.7 [5.77] 2.7	19.0 [5.57] 3.1	18.8 [5.51] 3.1	18.7 [5.48] 3.1	17.3 [5.07] 3.4	17.1 [5.01] 3.5	17.0 [4.98] 3.5
	15 [-9.4]	Total BTUH [kW] Power	23.0 [6.74] 2.7	22.8 [6.68] 2.7	22.7 [6.65] 2.7	22.0 [6.45] 3.1	21.8 [6.39] 3.1	21.7 [6.36] 3.2	20.3 [5.95] 3.5	20.1 [5.89] 3.5	20.0 [5.86] 3.5
	20 [-6.7]	Total BTUH [kW] Power	26.0 [7.62] 2.7	25.8 [7.56] 2.7	25.6 [7.50] 2.8	25.0 [7.33] 3.1	24.8 [7.27] 3.2	24.7 [7.24] 3.2	23.3 [6.83] 3.5	23.1 [6.77] 3.5	23.0 [6.74] 3.6
	25 [-3.9]	Total BTUH [kW] Power	29.0 [8.50] 2.8	28.8 [8.44] 2.8	28.6 [8.38] 2.8	28.0 [8.21] 3.2	27.8 [8.15] 3.2	27.6 [8.09] 3.3	26.3 [7.71] 3.5	26.1 [7.65] 3.6	26.0 [7.62] 3.6
	30 [-1.1]	Total BTUH [kW] Power	32.0 [9.38] 2.8	31.8 [9.32] 2.8	31.6 [9.26] 2.9	31.1 [9.11] 3.2	30.8 [9.03] 3.2	30.6 [8.97] 3.3	29.3 [8.59] 3.6	29.1 [8.53] 3.6	28.9 [8.47] 3.7
	35 [1.7]	Total BTUH [kW] Power	35.1 [10.29] 2.8	34.8 [10.20] 2.9	34.6 [10.14] 2.9	34.1 [9.99] 3.2	33.8 [9.91] 3.3	33.6 [9.85] 3.3	32.4 [9.50] 3.6	32.1 [9.41] 3.6	31.9 [9.35] 3.7
	40 [4.4]	Total BTUH [kW] Power	38.1 [11.17] 2.9	37.8 [11.08] 2.9	37.5 [10.99] 2.9	37.1 [10.87] 3.3	36.8 [10.79] 3.3	36.6 [10.73] 3.4	35.4 [10.37] 3.6	35.1 [10.29] 3.7	34.9 [10.23] 3.7
	45 [7.2]	Total BTUH [kW] Power	41.1 [12.05] 2.9	40.8 [11.96] 2.9	40.5 [11.87] 3.0	40.1 [11.75] 3.3	39.8 [11.66] 3.4	39.6 [11.61] 3.4	38.4 [11.25] 3.7	38.1 [11.17] 3.7	37.9 [11.11] 3.8
50 [10]	Total BTUH [kW] Power	44.1 [12.92] 2.9	43.8 [12.84] 3.0	43.5 [12.75] 3.0	43.1 [12.63] 3.4	42.8 [12.54] 3.4	42.5 [12.46] 3.4	41.4 [12.13] 3.7	41.1 [12.05] 3.8	40.8 [11.96] 3.8	

IDB—Indoor air dry bulb

[] Designates Metric Conversions





COOLING PERFORMANCE DATA—RQPW-048

		ENTERING INDOOR AIR @ 80°F [26.7°C] dbE									
		wbE	71°F [21.7°C]			67°F [19.4°C]			63°F [17.2°C]		
		CFM [L/s]	1760 [831]	1600 [755]	1440 [680]	1760 [831]	1600 [755]	1440 [680]	1760 [831]	1600 [755]	1440 [680]
		DR	.15	.13	.11	.15	.13	.11	.15	.13	.11
O U T D O O R D R Y B U L B T E M P E R A T U R E ° F [° C]	75 [23.9]	Total BTUH [kW] Sens BTUH [kW] Power	60.4 [17.70] 37.4 [10.96] 3.2	59.3 [17.38] 35.7 [10.46] 3.1	58.3 [17.09] 34.1 [9.99] 3.1	57.1 [16.73] 42.7 [12.51] 3.1	56.1 [16.44] 40.8 [11.96] 3.1	55.0 [16.12] 38.9 [11.40] 3.1	54.5 [15.97] 45.0 [13.19] 3.1	53.5 [15.68] 43.0 [12.60] 3.1	52.5 [15.39] 41.0 [12.02] 3.1
	80 [26.7]	Total BTUH [kW] Sens BTUH [kW] Power	58.8 [17.23] 36.6 [10.73] 3.4	57.8 [16.94] 35.0 [10.26] 3.3	56.7 [16.62] 33.3 [9.76] 3.3	55.5 [16.27] 41.9 [12.28] 3.3	54.5 [15.97] 40.0 [11.72] 3.3	53.5 [15.68] 38.2 [11.20] 3.3	52.9 [15.50] 44.2 [12.95] 3.3	51.9 [15.21] 42.2 [12.37] 3.3	51.0 [14.95] 40.3 [11.81] 3.2
	85 [29.4]	Total BTUH [kW] Sens BTUH [kW] Power	57.0 [16.71] 35.7 [10.46] 3.5	56.0 [16.41] 34.1 [9.99] 3.5	55.0 [16.12] 32.5 [9.52] 3.5	53.7 [15.74] 41.0 [12.02] 3.5	52.7 [15.44] 39.2 [11.49] 3.5	51.8 [15.18] 37.3 [10.93] 3.5	51.1 [14.98] 43.3 [12.69] 3.5	50.2 [14.71] 41.4 [12.13] 3.5	49.3 [14.45] 39.4 [11.55] 3.4
	90 [32.2]	Total BTUH [kW] Sens BTUH [kW] Power	55.1 [16.15] 34.8 [10.20] 3.7	54.1 [15.86] 33.2 [9.73] 3.7	53.1 [15.56] 31.7 [9.29] 3.7	51.7 [15.15] 40.1 [11.75] 3.7	50.8 [14.89] 38.3 [11.22] 3.7	49.9 [14.62] 36.5 [10.70] 3.6	49.1 [14.39] 42.4 [12.43] 3.7	48.3 [14.16] 40.5 [11.87] 3.6	47.4 [13.89] 38.6 [11.31] 3.6
	95 [35]	Total BTUH [kW] Sens BTUH [kW] Power	53.1 [15.56] 33.8 [9.91] 3.9	52.1 [15.27] 32.3 [9.47] 3.9	51.2 [15.01] 30.8 [9.03] 3.9	49.8 [14.59] 39.1 [11.46] 3.9	48.9 [14.33] 37.4 [10.96] 3.9	48.0 [14.07] 35.6 [10.43] 3.8	47.2 [13.83] 41.4 [12.13] 3.9	46.3 [13.57] 39.6 [11.61] 3.8	45.5 [13.33] 37.7 [11.05] 3.8
	100 [37.8]	Total BTUH [kW] Sens BTUH [kW] Power	51.1 [14.98] 32.9 [9.64] 4.1	50.2 [14.71] 31.4 [9.20] 4.1	49.3 [14.45] 29.9 [8.76] 4.0	47.8 [14.01] 38.2 [11.20] 4.1	46.9 [13.75] 36.5 [10.70] 4.0	46.1 [13.51] 34.8 [10.20] 4.0	45.2 [13.25] 40.5 [11.87] 4.1	44.4 [13.01] 38.7 [11.34] 4.0	43.6 [12.78] 36.9 [10.81] 4.0
	105 [40.6]	Total BTUH [kW] Sens BTUH [kW] Power	49.3 [14.45] 32.0 [9.38] 4.3	48.4 [14.18] 30.6 [8.97] 4.3	47.5 [13.92] 29.2 [8.56] 4.2	46.0 [13.48] 37.3 [10.93] 4.3	45.1 [13.22] 35.7 [10.46] 4.2	44.3 [12.98] 34.0 [9.96] 4.2	43.4 [12.72] 39.6 [11.61] 4.2	42.6 [12.48] 37.9 [11.11] 4.2	41.8 [12.25] 36.1 [10.58] 4.2
	110 [43.3]	Total BTUH [kW] Sens BTUH [kW] Power	47.6 [13.95] 31.3 [9.17] 4.5	46.8 [13.72] 29.9 [8.76] 4.4	45.9 [13.45] 28.5 [8.35] 4.4	44.3 [12.98] 36.6 [10.73] 4.5	43.5 [12.75] 34.9 [10.23] 4.4	42.7 [12.51] 33.3 [9.76] 4.4	41.7 [12.22] 38.9 [11.40] 4.4	41.0 [12.02] 37.1 [10.87] 4.4	40.2 [11.78] 35.4 [10.37] 4.4
	115 [46.1]	Total BTUH [kW] Sens BTUH [kW] Power	46.3 [13.57] 30.7 [9.00] 4.7	45.5 [13.33] 29.3 [8.59] 4.6	44.6 [13.07] 27.9 [8.18] 4.6	43.0 [12.60] 36.0 [10.55] 4.6	42.2 [12.37] 34.4 [10.08] 4.6	41.4 [12.13] 32.8 [9.61] 4.6	40.4 [11.84] 38.3 [11.22] 4.6	39.6 [11.61] 36.6 [10.73] 4.6	38.9 [11.40] 34.8 [10.20] 4.5

DR —Depression ratio
dbE —Entering air dry bulb
wbE—Entering air wet bulb

Total —Total capacity x 1000 BTUH
Sens —Sensible capacity x 1000 BTUH
Power —KW input

NOTES:
When the entering air dry bulb is other than 80°F [27°C], adjust the sensible capacity from the table by adding [1.10 x CFM x (1 - DR) x (dbE - 80)].

HEATING PERFORMANCE DATA—RQPW-048

		IDB	60°F [15.5°C]			70°F [21.1°C]			80°F [26.7°C]		
		CFM [L/s]	1760 [831]	1600 [755]	1440 [680]	1760 [831]	1600 [755]	1440 [680]	1760 [831]	1600 [755]	1440 [680]
O U T D O O R D R Y B U L B T E M P E R A T U R E ° F [° C]	0 [-17.8]	Total BTUH [kW] Power	16.9 [4.95] 2.6	16.8 [4.92] 2.6	16.7 [4.89] 2.6	15.4 [4.51] 3.0	15.3 [4.48] 3.0	15.2 [4.45] 3.0	14.4 [4.22] 3.4	14.3 [4.19] 3.5	14.2 [4.16] 3.5
	5 [-15]	Total BTUH [kW] Power	20.1 [5.89] 2.6	19.9 [5.83] 2.6	19.8 [5.80] 2.7	18.6 [5.45] 3.0	18.5 [5.42] 3.0	18.3 [5.36] 3.1	17.6 [5.16] 3.5	17.5 [5.13] 3.5	17.3 [5.07] 3.5
	10 [-12.2]	Total BTUH [kW] Power	23.2 [6.80] 2.7	23.1 [6.77] 2.7	22.9 [6.71] 2.7	21.8 [6.39] 3.1	21.6 [6.33] 3.1	21.5 [6.30] 3.1	20.7 [6.07] 3.5	20.6 [6.04] 3.6	20.5 [6.01] 3.6
	15 [-9.4]	Total BTUH [kW] Power	26.4 [7.74] 2.7	26.2 [7.68] 2.8	26.0 [7.62] 2.8	24.9 [7.30] 3.1	24.7 [7.24] 3.2	24.6 [7.21] 3.2	23.9 [7.00] 3.6	23.7 [6.95] 3.6	23.6 [6.92] 3.7
	20 [-6.7]	Total BTUH [kW] Power	29.6 [8.67] 2.8	29.3 [8.59] 2.8	29.1 [8.53] 2.8	28.1 [8.24] 3.2	27.9 [8.18] 3.2	27.7 [8.12] 3.2	27.1 [7.94] 3.6	26.9 [7.88] 3.7	26.7 [7.83] 3.7
	25 [-3.9]	Total BTUH [kW] Power	32.7 [9.58] 2.8	32.5 [9.52] 2.9	32.2 [9.44] 2.9	31.2 [9.14] 3.2	31.0 [9.09] 3.3	30.8 [9.03] 3.3	30.2 [8.85] 3.7	30.0 [8.79] 3.7	29.8 [8.73] 3.8
	30 [-1.1]	Total BTUH [kW] Power	35.9 [10.52] 2.9	35.6 [10.43] 2.9	35.4 [10.37] 2.9	34.4 [10.08] 3.3	34.1 [9.99] 3.3	33.9 [9.94] 3.4	33.4 [9.79] 3.7	33.1 [9.70] 3.8	32.9 [9.64] 3.8
	35 [1.7]	Total BTUH [kW] Power	39.0 [11.43] 2.9	38.7 [11.34] 3.0	38.5 [11.28] 3.0	37.6 [11.02] 3.3	37.3 [10.93] 3.4	37.0 [10.84] 3.4	36.5 [10.70] 3.8	36.3 [10.64] 3.8	36.0 [10.55] 3.9
	40 [4.4]	Total BTUH [kW] Power	42.2 [12.37] 3.0	41.9 [12.28] 3.0	41.6 [12.19] 3.1	40.7 [11.93] 3.4	40.4 [11.84] 3.4	40.1 [11.75] 3.5	39.7 [11.63] 3.8	39.4 [11.55] 3.9	39.1 [11.46] 3.9
	45 [7.2]	Total BTUH [kW] Power	45.3 [13.28] 3.0	45.0 [13.19] 3.1	44.7 [13.10] 3.1	43.9 [12.87] 3.4	43.6 [12.78] 3.5	43.2 [12.66] 3.5	42.8 [12.54] 3.9	42.5 [12.46] 3.9	42.2 [12.37] 4.0
50 [10]	Total BTUH [kW] Power	48.5 [14.21] 3.1	48.2 [14.13] 3.1	47.8 [14.01] 3.2	47.0 [13.77] 3.5	46.7 [13.69] 3.5	46.4 [13.60] 3.6	46.0 [13.48] 3.9	45.7 [13.39] 4.0	45.4 [13.31] 4.0	

IDB—Indoor air dry bulb

[] Designates Metric Conversions



INDOOR AIRFLOW PERFORMANCE—208 VOLTS

Nominal Cooling Capacity Tons [kW]	Motor Speed from Factory		Heat Pump Recommended Airflow (Min/Max) CFM	Blower Size/ Motor HP [W] & # of Speeds	Motor Speed	External Static Pressure ^N inches W.C. [kPa] (Side Discharge ^N Wet Coil)								
	HP (Cool/Heat)	Gas Heat				0.1 [0.02]	0.2 [0.05]	0.3 [0.07]	0.4 [0.10]	0.5 [0.12]	0.6 [0.15]	0.7 [0.17]	0.8 [0.20]	
2.0 [7.03]	High HP (Tap 3)	Gas Heat (Tap 5)	700 CFM/900 CFM [330/425 L/s]	9 x 7 Blower 1/3 HP [249 W] 4 Speed X13 Motor	Cont. Fan Dedicated (Tap 1)	CFM [l/s]	821 [387]	799 [377]	775 [366]	742 [350]	706 [333]	681 [321]	641 [303]	611 [288]
					RPM	878	903	953	1032	1075	1119	1176		
					Watts	131	134	142	145	147	154	156	161	
					Low HP (Cool/Heat) (Tap 2)	CFM [l/s]	847 [400]	818 [386]	788 [372]	765 [361]	737 [348]	695 [328]	659 [311]	581 [274]
					RPM	892	818	788	765	737	695	659	581	
Watts	145	147	156	164	167	167	167	155						
2.5 [8.79]	Med HP (Tap 3)	Gas Heat (Tap 5)	875 CFM/1125 CFM [652/839 L/s]	10 x 9 Blower 1/2 HP [373 W] 5 Speed X13 Motor	Cont. Fan Dedicated (Tap 1)	CFM [l/s]	914 [431]	887 [419]	853 [403]	824 [389]	793 [374]	762 [360]	717 [338]	602 [284]
					RPM	934	971	1024	1053	1083	1121	1135	1155	
					Watts	173	177	185	186	188	192	185	164	
					Gas Heat Dedicated (Tap 5)	CFM [l/s]	821 [387]	799 [377]	775 [366]	742 [350]	706 [333]	681 [321]	641 [303]	611 [288]
					RPM	878	903	953	996	1032	1075	1119	1176	
Watts	131	134	142	145	147	154	156	161						
3.0 [10.55]	Med HP (Tap 3)	Gas Heat (Tap 5)	1050 CFM/1350 CFM [782/1007 L/s]	10 x 9 Blower 1/2 HP [373 W] 5 Speed X13 Motor	Cont. Fan Dedicated (Tap 1)	CFM [l/s]	1067 [504]	1034 [488]	992 [468]	957 [452]	912 [430]	820 [387]	778 [367]	729 [344]
					RPM	719	749	791	819	876	952	1020	1053	
					Watts	143	145	155	159	169	182	185	192	
					Med HP (Cool/Heat) (Tap 3)	CFM [l/s]	1165 [550]	1132 [534]	1091 [515]	1051 [496]	1009 [476]	959 [453]	855 [404]	819 [387]
					RPM	744	785	833	864	905	951	1020	1053	
Watts	167	177	188	191	202	206	217	351						
3.0 [10.55]	Med HP (Tap 3)	Gas Heat (Tap 5)	1050 CFM/1350 CFM [782/1007 L/s]	10 x 9 Blower 1/2 HP [373 W] 5 Speed X13 Motor	High HP (Cool/Heat) (Tap 4)	CFM [l/s]	1252 [591]	1213 [572]	1166 [550]	1137 [537]	1099 [519]	1046 [494]	986 [465]	892 [421]
					RPM	796	826	868	893	934	982	1026	1086	
					Watts	206	210	219	225	234	245	248	256	
					Gas Heat Dedicated (Tap 5)	CFM [l/s]	1228 [580]	1187 [560]	1140 [538]	1105 [522]	1062 [501]	1008 [476]	959 [453]	911 [430]
					RPM	761	808	841	884	920	960	999	1038	
Watts	150	170	180	183	185	190	195	215						
3.0 [10.55]	Med HP (Tap 3)	Gas Heat (Tap 5)	1050 CFM/1350 CFM [782/1007 L/s]	10 x 9 Blower 1/2 HP [373 W] 5 Speed X13 Motor	Cont. Fan Dedicated (Tap 1)	CFM [l/s]	1228 [580]	1187 [560]	1140 [538]	1105 [522]	1062 [501]	1008 [476]	959 [453]	911 [430]
					RPM	761	808	841	884	920	960	999	1038	
					Watts	150	170	180	183	185	190	195	215	
					Low HP (Cool/Heat) (Tap 2)	CFM [l/s]	1247 [589]	1220 [576]	1178 [556]	1143 [539]	1099 [519]	1064 [502]	998 [471]	904 [427]
					RPM	784	819	863	890	932	957	1012	1075	
Watts	200	208	219	224	233	236	246	256						
3.0 [10.55]	Med HP (Tap 3)	Gas Heat (Tap 5)	1050 CFM/1350 CFM [782/1007 L/s]	10 x 9 Blower 1/2 HP [373 W] 5 Speed X13 Motor	Med HP (Cool/Heat) (Tap 3)	CFM [l/s]	1307 [617]	1292 [610]	1238 [584]	1214 [573]	1170 [552]	1135 [536]	1087 [513]	989 [487]
					RPM	820	850	889	918	944	981	1028	1087	
					Watts	233	242	248	255	262	268	277	284	
					High HP (Cool/Heat) (Tap 4)	CFM [l/s]	1396 [659]	1357 [640]	1334 [630]	1286 [607]	1253 [591]	1207 [570]	1163 [549]	1103 [521]
					RPM	864	898	920	942	976	1010	1043	1089	
Watts	268	280	288	292	299	304	310	316						
3.0 [10.55]	Med HP (Tap 3)	Gas Heat (Tap 5)	1050 CFM/1350 CFM [782/1007 L/s]	10 x 9 Blower 1/2 HP [373 W] 5 Speed X13 Motor	Gas Heat Dedicated (Tap 5)	CFM [l/s]	1228 [580]	1187 [560]	1140 [538]	1105 [522]	1062 [501]	1008 [476]	959 [453]	911 [430]
					RPM	761	808	841	884	920	960	999	1038	
					Watts	150	170	180	183	185	190	195	215	
					High HP (Cool/Heat) (Tap 4)	CFM [l/s]	1247 [589]	1220 [576]	1178 [556]	1143 [539]	1099 [519]	1064 [502]	998 [471]	904 [427]
					RPM	784	819	863	890	932	957	1012	1075	
Watts	200	208	219	224	233	236	246	256						

NOTES: Do not connect wiring to unspecified speed taps.
Heat Pump speed must be changed to Low to achieve AHRI performance.

[] Designates Metric Conversions

INDOOR AIRFLOW PERFORMANCE—208 VOLTS (cont.)

Nominal Cooling Capacity Tons [kW]	Motor Speed from Factory		Heat Pump Recommended Airflow (Min/Max) CFM	Blower Size/ Motor HP [W] & # of Speeds	Motor Speed	External Static Pressure (Side Discharge/NWet Coil)								
	HP (Cool/Heat)	Gas Heat				0.1 [.02]	0.2 [.05]	0.3 [.07]	0.4 [.10]	0.5 [.12]	0.6 [.15]	0.7 [.17]	0.8 [.20]	
3.5 [12.31]	High HP (Tap 3)	Gas Heat (Tap 5)	1225 CFM/1575 CFM [913/1174 L/s]	10 x 9 Blower 3/4 HP [559 W] 4 Speed X13 Motor	Cont. Fan Dedicated (Tap 1)	CFM [l/s]	1454 [686]	1433 [676]	1392 [657]	1354 [639]	1322 [624]	1283 [606]	1238 [584]	1192 [563]
					Watts	923	946	976	1015	1044	1085	1126	1146	
					Low HP (Cool/Heat) (Tap 2)	CFM [l/s]	1455 [687]	1431 [675]	1396 [659]	1360 [642]	1315 [621]	1285 [606]	1241 [586]	
					Watts	824	856	889	931	968	1009	1041		
					High HP (Cool/Heat) (Tap 3)	CFM [l/s]	1559 [736]	1530 [722]	1488 [702]	1454 [686]	1417 [669]	1375 [649]	1336 [631]	
					RPM	870	893	932	968	1007	1036	1072		
					Watts	321	327	338	351	364	371	381		
4.0 [14.07]	High HP (Tap 3)	Gas Heat (Tap 5)	1350 CFM/1700 CFM [1007/1268 L/s]	10 x 9 Blower 3/4 HP [559 W] 4 Speed X13 Motor	Gas Heat Dedicated (Tap 5)	CFM [l/s]	1454 [686]	1433 [676]	1392 [657]	1354 [639]	1322 [624]	1283 [606]	1238 [584]	1192 [563]
					Watts	923	946	976	1015	1044	1085	1126	1146	
					Cont. Fan Dedicated (Tap 1)	CFM [l/s]	1454 [686]	1433 [676]	1392 [657]	1354 [639]	1322 [624]	1283 [606]	1238 [584]	1192 [563]
					Watts	301	309	316	327	337	348	356	363	
					Low HP (Cool/Heat) (Tap 2)	CFM [l/s]	1675 [791]	1658 [782]	1610 [760]	1580 [746]	1535 [724]	1491 [704]	1422 [671]	
					RPM	923	944	979	1013	1045	1077	1098		
					Watts	390	401	412	425	433	440	432		
					High HP (Cool/Heat) (Tap 3)	CFM [l/s]	1770 [835]	1751 [826]	1706 [805]	1672 [789]	1624 [766]	1555 [734]	1463 [690]	
					RPM	966	989	1018	1050	1078	1100	1115		
					Watts	454	466	473	486	490	481	460		
					Gas Heat Dedicated (Tap 5)	CFM [l/s]	1454 [686]	1433 [676]	1392 [657]	1354 [639]	1322 [624]	1283 [606]	1238 [584]	1192 [563]
					RPM	923	946	976	1015	1044	1085	1126	1146	
					Watts	301	309	316	327	337	348	356	363	

NOTES: Do not connect wiring to unspecified speed taps.
Heat Pump speed must be changed to Low to achieve AHRI performance.

DOWN DISCHARGE PRESSURE DROP (ADD TO EXTERNAL STATIC PRESSURE)						
CFM [L/s]	600 [283]	800 [378]	1000 [472]	1200 [566]	1400 [661]	1600 [775]
Pressure Drop [Inches W.C. [kPa]]	.00	.01 [.002]	.02 [.005]	.03 [.007]	.05 [.012]	.07 [.017]

[J] Designates Metric Conversions

INDOOR AIRFLOW PERFORMANCE—230 VOLTS

Nominal Cooling Capacity Tons [kW]	Motor Speed from Factory		Heat Pump Recommended Airflow (Min/Max) CFM	Blower Size/ Motor HP [W] & # of Speeds	Motor Speed	External Static Pressure ^N Inches W.C. [kPa] (Side Discharge ^N Wet Coil)								
	HP (Cool/Heat)	Gas Heat				0.1 [0.2]	0.2 [0.05]	0.3 [0.07]	0.4 [0.10]	0.5 [0.12]	0.6 [0.15]	0.7 [0.17]	0.8 [0.20]	
2.0 [7.03]	High HP (Tap 3)	Gas Heat (Tap 5)	700 CFM/900 CFM [330/425 L/s]	9 x 7 Blower 1/3 HP [249 W] 4 Speed X13 Motor	Cont. Fan Dedicated (Tap 1)	CFM [l/s]	829 [391]	808 [381]	789 [372]	756 [357]	737 [348]	697 [329]	668 [315]	615 [290]
					RPM	890	915	961	1000	1046	1089	1121	1173	
					Watts	137	139	148	151	160	163	166	167	
					Low HP (Cool/Heat) (Tap 2)	CFM [l/s]	862 [407]	834 [394]	819 [387]	781 [369]	761 [359]	729 [344]	695 [328]	606 [286]
					RPM	889	953	974	1018	1065	1101	1133	1156	
Watts	151	159	162	166	173	176	180	165						
2.5 [8.79]	Med HP (Tap 3)	Gas Heat (Tap 5)	875 CFM/1125 CFM [652/839 L/s]	10 x 9 Blower 1/2 HP [373 W] 5 Speed X13 Motor	Cont. Fan Dedicated (Tap 1)	CFM [l/s]	1187 [560]	1124 [530]	1096 [517]	1071 [505]	1024 [483]	987 [466]	896 [423]	852 [402]
					RPM	762	799	832	859	914	940	1021	1059	
					Watts	176	182	191	196	209	212	227	235	
					Low HP (Cool/Heat) (Tap 2)	CFM [l/s]	1271 [600]	1223 [577]	1169 [552]	1137 [537]	1104 [521]	1071 [505]	1015 [479]	934 [441]
					RPM	797	836	878	905	939	974	1026	1089	
Watts	212	217	227	231	241	247	257	270						
3.0 [10.55]	Med HP (Tap 3)	Gas Heat (Tap 5)	1050 CFM/1350 CFM [782/1007 L/s]	10 x 9 Blower 1/2 HP [373 W] 5 Speed X13 Motor	Gas Heat Dedicated (Tap 5)	CFM [l/s]	1241 [586]	1203 [568]	1155 [545]	1119 [528]	1082 [511]	1032 [487]	994 [469]	950 [448]
					RPM	771	815	848	886	932	965	1004	1044	
					Watts	155	162	170	182	193	200	210	220	
					Low HP (Cool/Heat) (Tap 2)	CFM [l/s]	1258 [594]	1215 [573]	1200 [566]	1160 [547]	1130 [533]	1082 [511]	1026 [484]	954 [450]
					RPM	802	829	861	894	933	971	1020	1077	
Watts	210	217	225	230	239	245	259	268						
3.0 [10.55]	Med HP (Tap 3)	Gas Heat (Tap 5)	1050 CFM/1350 CFM [782/1007 L/s]	10 x 9 Blower 1/2 HP [373 W] 5 Speed X13 Motor	Med HP (Cool/Heat) (Tap 3)	CFM [l/s]	1336 [631]	1298 [613]	1259 [594]	1229 [580]	1198 [566]	1160 [547]	1116 [527]	1071 [505]
					RPM	821	867	903	920	957	993	1038	1071	
					Watts	239	249	259	262	275	279	290	299	
					High HP (Cool/Heat) (Tap 4)	CFM [l/s]	1416 [668]	1379 [651]	1342 [633]	1292 [610]	1275 [602]	1240 [585]	1200 [566]	1168 [551]
					RPM	874	898	933	952	993	1011	1060	1091	
Watts	285	290	299	304	314	322	328	337						
3.0 [10.55]	Gas Heat Dedicated (Tap 5)	Gas Heat (Tap 5)	1050 CFM/1350 CFM [782/1007 L/s]	10 x 9 Blower 1/2 HP [373 W] 5 Speed X13 Motor	Gas Heat Dedicated (Tap 5)	CFM [l/s]	1241 [586]	1203 [568]	1155 [545]	1119 [528]	1082 [511]	1032 [487]	994 [469]	950 [448]
					RPM	771	815	848	886	932	965	1004	1044	
					Watts	155	162	170	182	193	200	210	220	
					Low HP (Cool/Heat) (Tap 2)	CFM [l/s]	1258 [594]	1215 [573]	1200 [566]	1160 [547]	1130 [533]	1082 [511]	1026 [484]	954 [450]
					RPM	802	829	861	894	933	971	1020	1077	
Watts	210	217	225	230	239	245	259	268						

NOTES: Italic type indicates airflow outside of manufacturers recommendation. Do not connect wiring to unspecified speed taps.

Heat Pump speed must be changed to Low to achieve AHRI performance.

[] Designates Metric Conversions

INDOOR AIRFLOW PERFORMANCE—230 VOLTS (cont.)

Nominal Cooling Capacity Tons [kW]	Motor Speed from Factory		Heat Pump Recommended Airflow (Min/Max) CFM	Blower Size/Motor HP [W] & # of Speeds	Motor Speed	External Static Pressure [†] Inches W.C. [kPa] (Side Discharge/Wet Coil)									
	HP (Cool/Heat)	Gas Heat				0.1 [.02]	0.2 [.05]	0.3 [.07]	0.4 [.10]	0.5 [.12]	0.6 [.15]	0.7 [.17]	0.8 [.20]		
3.5 [12.31]		Gas Heat (Tap 5)	1225 CFM/1575 CFM [913/1174 L/s]	10 x 9 Blower 3/4 HP [559 W] 4 Speed X13 Motor	Cont. Fan Dedicated (Tap 1)	CFM [l/s]	1459 [689]	1438 [679]	1409 [665]	1371 [647]	1337 [631]	1296 [612]	1258 [594]	1223 [577]	
						RPM	931	958	993	1031	1058	1097	1133	1158	
	Low HP (Cool/Heat) (Tap 2)	CFM [l/s]			1467 [692]	1439 [679]	1408 [665]	1360 [642]	1331 [628]	1287 [607]	1259 [594]				
		RPM			831	854	894	932	972	1005	1042				
	High HP (Cool/Heat) (Tap 3)	CFM [l/s]			1550 [732]	1520 [717]	1486 [701]	1449 [684]	1407 [664]	1382 [652]	1337 [631]	1309	1073		
4.0 [14.07]		Gas Heat (Tap 5)	1350 CFM/1700 CFM [1007/1268 L/s]	10 x 9 Blower 3/4 HP [559 W] 4 Speed X13 Motor	Cont. Fan Dedicated (Tap 1)	CFM [l/s]	1459 [689]	1438 [679]	1409 [665]	1371 [647]	1337 [631]	1296 [612]	1258 [594]	1223 [577]	
						RPM	931	958	993	1031	1058	1097	1133	1158	
	Low HP (Cool/Heat) (Tap 2)	CFM [l/s]			1692 [799]	1661 [784]	1633 [771]	1589 [750]	1560 [736]	1512 [714]	1442 [681]				
		RPM			931	950	982	1018	1054	1082	1103				
	High HP (Cool/Heat) (Tap 3)	CFM [l/s]			1748 [825]	1718 [811]	1686 [796]	1647 [777]	1616 [763]	1543 [728]	1472 [695]				
					RPM	955	978	1010	1043	1073	1096	1111			
					Watts	440	446	462	475	484	473	459			
					CFM [l/s]	1459 [689]	1438 [679]	1409 [665]	1371 [647]	1337 [631]	1296 [612]	1258 [594]	1223 [577]		
					RPM	931	958	993	1031	1058	1097	1133	1158		
					Watts	308	319	331	339	349	362	373	381		

NOTES: *Italic type* indicates airflow outside of manufacturer's recommendation. Do not connect wiring to unspecified speed taps.

[†]Heat Pump speed must be changed to Low to achieve AHRI performance.

DOWN DISCHARGE PRESSURE DROP (ADD TO EXTERNAL STATIC PRESSURE)						
CFM [L/s]	600 [283]	800 [378]	1000 [472]	1200 [566]	1400 [661]	1600 [775]
Pressure Drop [Inches W.C. [kPa]]	.00	.01 [.002]	.02 [.005]	.03 [.007]	.05 [.012]	.07 [.017]

[] Designates Metric Conversions

ELECTRICAL DATA Ð RQPW- SERIES								
		B024JK	B025JK	B030JK	B036CK	B036JK	B042JK	B048JK
Unit Information	Unit Operating Voltage Range	187-253	187-253	187-253	187-253	187-253	187-253	187-253
	Volts	208/230	208/230	208/230	208/230	208/230	208/230	208/230
	Minimum Circuit Ampacity	21/21	21/21	24/24	19/19	27/27	33/33	37/37
	Minimum Overcurrent Protection Device Size	25/25	25/25	25/25	20/20	30/30	35/35	40/40
	Maximum Overcurrent Protection Device Size	30/30	30/30	35/35	25/25	40/40	50/50	50/50
Compressor Motor	No.	1	1	1	1	1	1	1
	Volts	208/230	208/230	208/230	200/230	208/230	208/230	208/230
	Phase	1	1	1	3	1	1	1
	HP	3450	3450	3450	3450	3450	3450	3450
	RPM	2	2	2 1/2	3	3	3 1/2	4
	Amps (RLA)	12.8/12.8	12.8/12.8	14.1/14.1	10.4/10.4	16.7/16.7	19.9/19.9	23.8/23.8
	Amps (LRA)	58.3/58.3	58.3/58.3	73/73	88/88	79/79	109/109	117/117
Condenser Motor	No.	1	1	1	1	1	1	1
	Volts	208/230	208/230	208/230	208/230	208/230	208/230	208/230
	Phase	1	1	1	1	1	1	1
	HP	1/3	1/3	1/3	1/3	1/3	1/3	1/3
	Amps (FLA)	1.3/1.3	1.3/1.3	1.3/1.3	1.3/1.3	1.3/1.3	2/2	2/2
	Amps (LRA)	2.2/2.2	2.2/2.2	2.2/2.2	2.2/2.2	2.2/2.2	3.9/3.9	3.9/3.9
Evaporator Fan	No.	1	1	1	1	1	1	1
	Volts	208/230	208/230	208/230	208/230	208/230	208/230	208/230
	Phase	1	1	1	1	1	1	1
	HP	1/3	1/3	1/2	1/2	1/2	3/4	3/4
	Amps (FLA)	2.8/2.8	2.8/2.8	4.1/4.1	4.1/4.1	4.1/4.1	6/6	6/6
	Amps (LRA)	0/0	0/0	0/0	0/0	0/0	0/0	0/0

1. Horsepower Per Compressor.

2. Amp Draw Per Motor. Multiply Value By Number of Motors to Determine Total Amps.

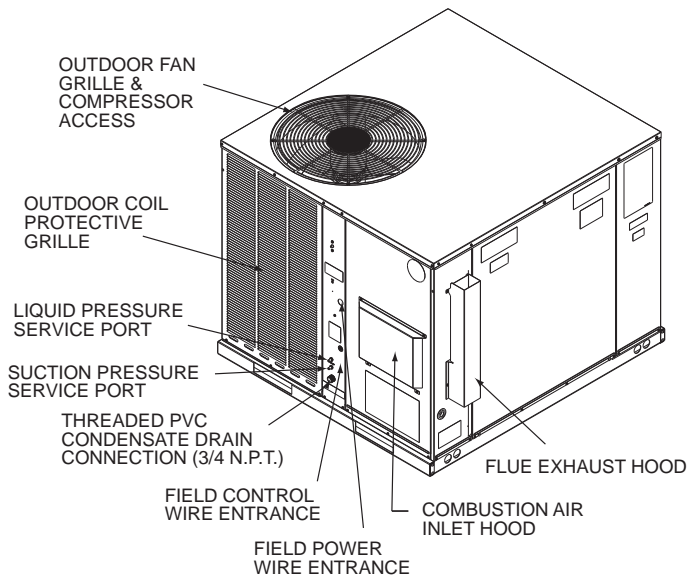

TOP VIEW

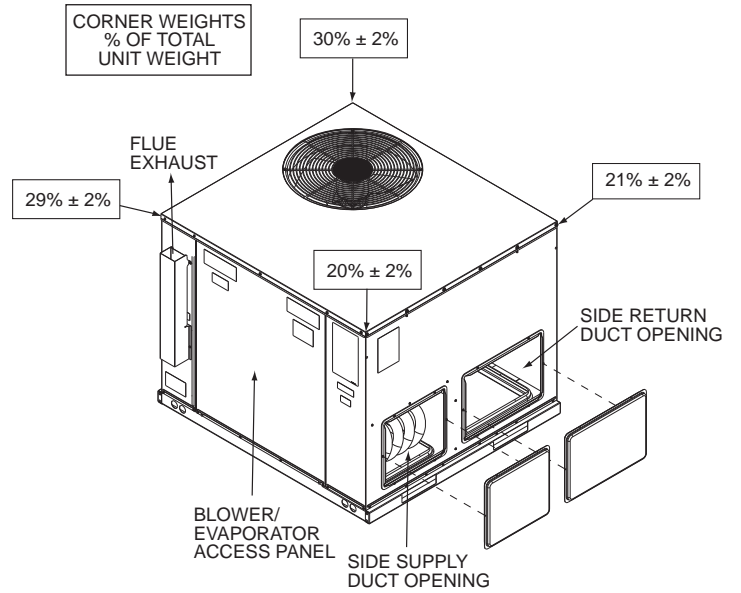
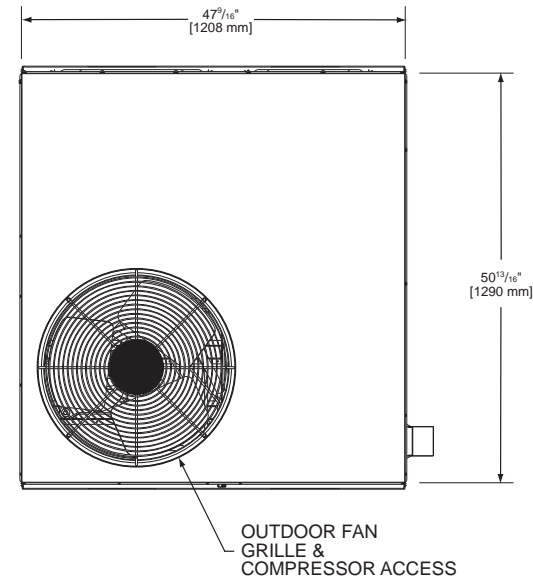

BOTTOM VIEW

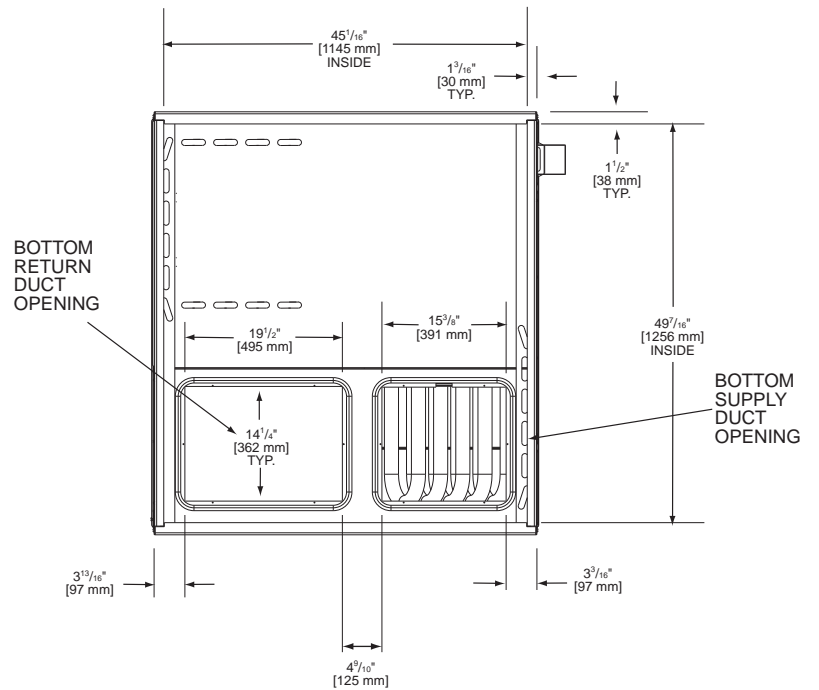

[] Designates Metric Conversions

SIDE VIEW

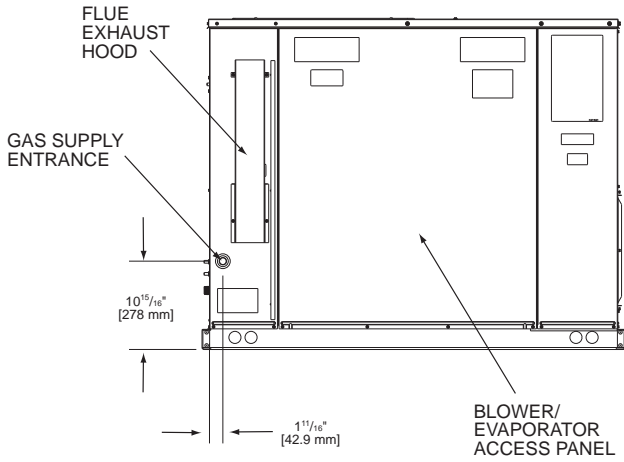

SIDE VIEW

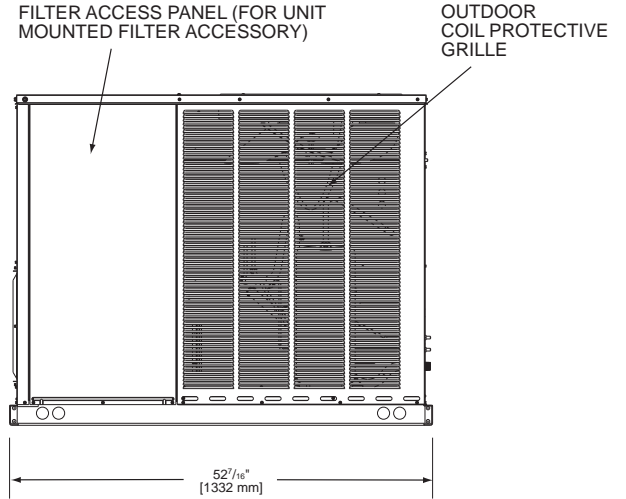

FRONT VIEW

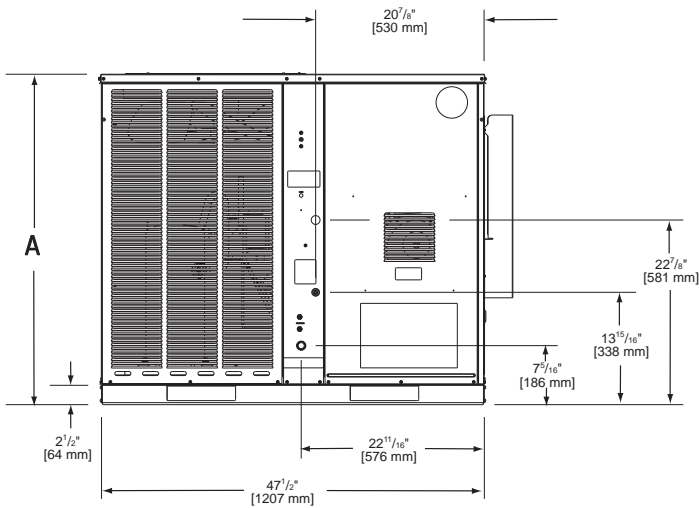

BACK VIEW

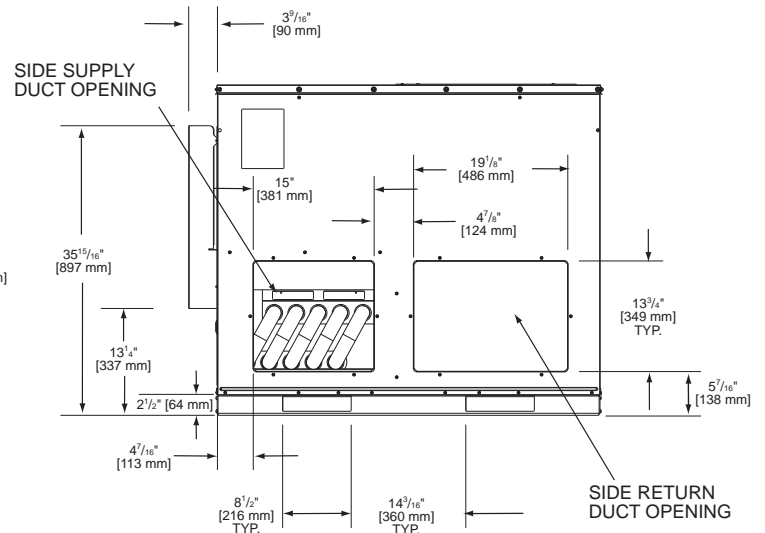

SHOWN WITH DUCT COVERS REMOVED.

IMPORTANT:
INSTALLATION MUST NOT INTERFERE WITH DRAINAGE OPENINGS IN BOTTOM OF UNIT UNDER OUTDOOR COIL.

Model #	"A" Height
B024, B025	35 ¹⁵ / ₁₆ "
B030, B036 B042, B048	41"

[] Designates Metric Conversions

ROOFTOP

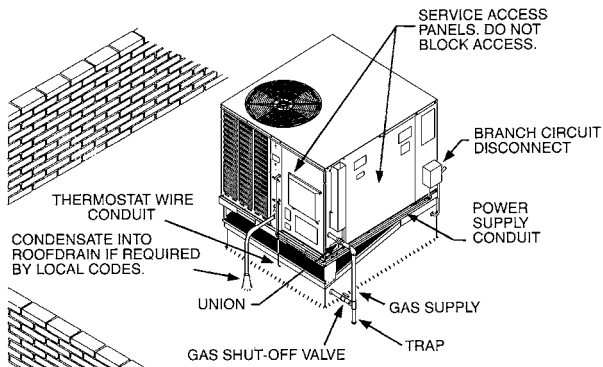
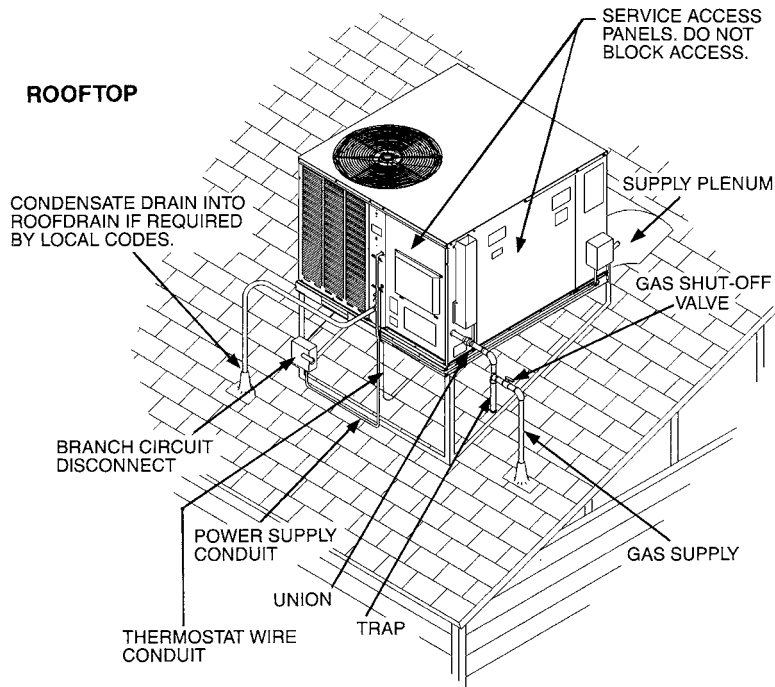

ROOFTOP

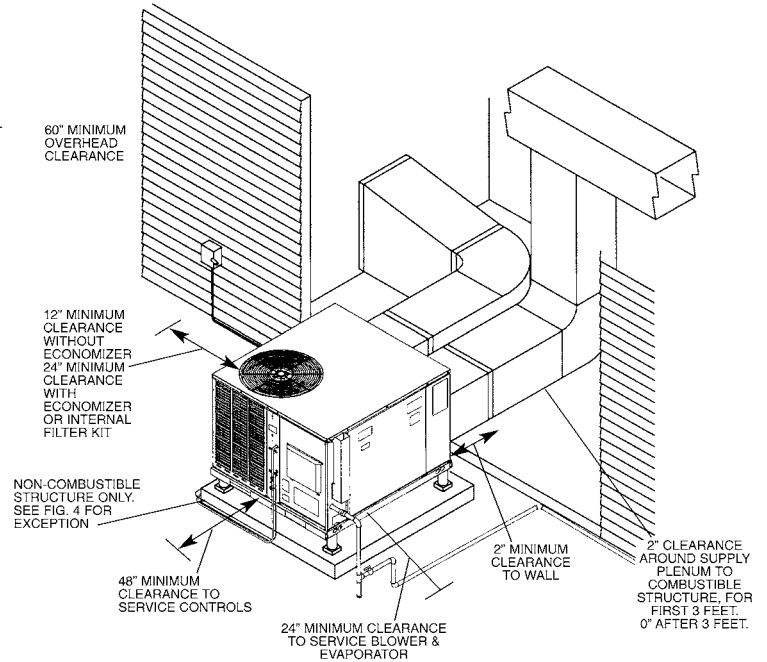

ACCESSORY EQUIPMENT

Accessory Description	Model Application	Accessory Model No.
Roofcurbs	RQPW-	RXQG-AAA14 (14" [356 mm] Height) RXQG-AAA24 (24" [610 mm] Height)
Thermostat with Outdoor Sensor	RQPW-	RHC-TST402DFMS
Supply & Return Diffusers	RQPW-	RXRN-D15
Economizers (Downflow Only)	RQPW-	AXRE-CAA30 (3 Position) AXRD-CAM10 (Fully Modulating)
Economizers (Sideflow Only)	RQPW-	AXRE-CCA30 (3 Position) AXRD-CCM10 (Fully Modulating)
Fresh Air Damper	RQPW-	AXRF-FAB1 (Motorized-35%) AXRF-FAA1 (Fixed-35%)
Rectangular to Round Transition (Downflow)	RQPW-	RXMC-CA02 (16" [406 mm] Ducts) RXMC-CA03 (18" [457 mm] Ducts)
Filter Kit	RQPW-	RXRY-01
Low Ambient Control	RQPW-	RXPZ-G01
High Pressure Control	RQPW-	RXAB-D01
Sideflow Rectangular to Round Transition	RQPW-	AXMC-BA01
LP Conversion Kits	RQPW-	RXGJ-EP84W (White-Rodgers Gas Valve) RXGJ-EP85H (Honeywell Gas Valve)
Canadian High Altitude Kit (for Natural Gas only*)	RQPW-	RXRX-AH01
Lift Kit	RQPW-	RXML-A01

*If a particular unit is to be converted to operate on LP (propane) for elevations above 2000 ft. [609.6 m] in Canada, the existing Natural Gas to LP Conversion Kits for the subject models already contain the necessary orifices and instructions to de-rate the input for 2000-4500 ft. [609.6-1371.6 m] Canadian applications.

[] Designates Metric Conversions

DUAL FUEL THERMOSTAT



This thermostat is pre-configured ready to operate the Package Dual Fuel Unit right out of the box with no programming required. This thermostat also contains a outdoor air sensor that allows for optimal efficiency and comfort from the Package Dual Fuel Unit.

COMMON SUPPLY/RETURN CONCENTRIC AIR DIFFUSER

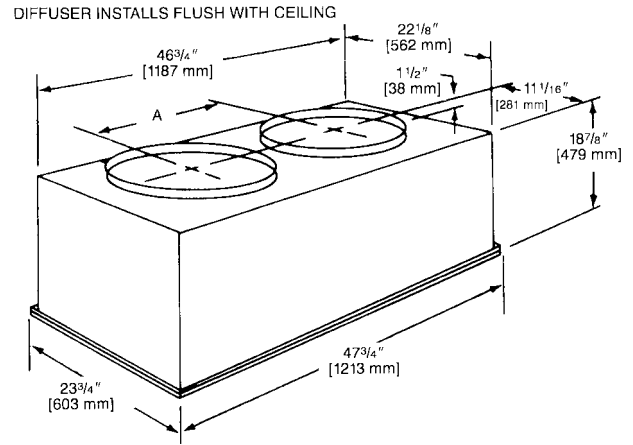
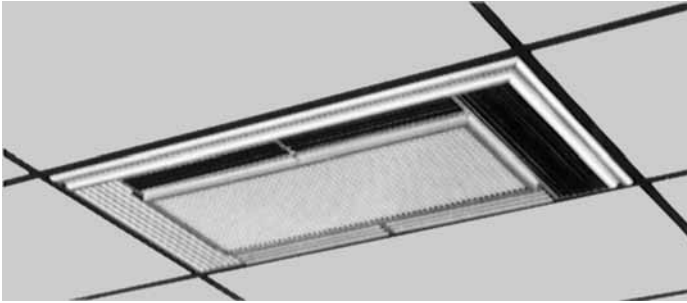

SUPPLY/RETURN DIFFUSER

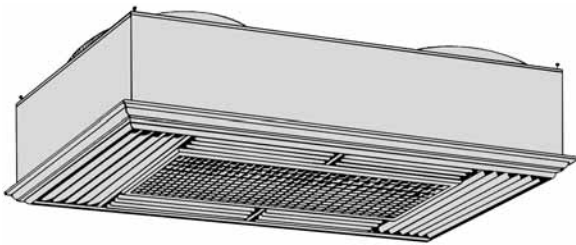

Designed to convert a side by side or an over and under arrangement into a concentric distribution of air. The diffuser is flush mounted, completely insulated, assembled, and internally baffled to provide four way supply air distribution with a center return. To make the assembly complete and ready to fit into a 2' [0.61 m] x 4' [1.22 m] suspended ceiling grid, the diffuser includes adjustable supply louvers, hanging rings, anti-sweat gasket, and round flanges for use with flexible ducts.

Model No.	Diameter Inches [mm]	Shipping Wt. Lbs. [kg]	Dimension A Inches [mm]
RXRN-			
BD15	16 [406]	90 [40.82]	20 1/2 [521]

NOTE: The location of the combination supply and return diffuser should not exceed 10 feet [3.05 m] above the floor level for units @ 1000 CFM [472 L/s] or less and 12 [3.66 m] to 14 feet [4.27 m] above the floor level for units with CFM greater than 1000 [472 L/s]. If the diffuser is installed with a greater distance than recommended above, the supply air may become stratified above the required comfort area causing uncomfortable conditions.

AIRFLOW/PRESSURE DROP INFORMATION (INCHES W.C. [kPa])

Accessory	Approximate CFM [L/s]-Supply Air			
	1300 [614]	1575 [743]	1800 [850]	2200 [1038]
Plenum & Supply/Return Diffuser	.07 [.017]	.10 [.024]	.12 [.030]	.17 [.042]
Diffuser	.09 [.022]	.13 [.032]	.16 [.040]	.24 [.060]
Economizer	.06 [.015]	.09 [.022]	.11 [.027]	.17 [.042]

SUPPLY AIR/PERFORMANCE

Diffuser Airflow CFM [L/s]	Range of Throw Ft. [m]
800 [378]-1200 [566]	14 [4.27]-16 [4.88]
1600 [755]-2000 [944]	18 [5.49]-28 [8.53]

[] Designates Metric Conversions

DUCT ADAPTERS RECTANGULAR TO ROUND TRANSITIONS (DOWNFLOW)

RXMC-CA02

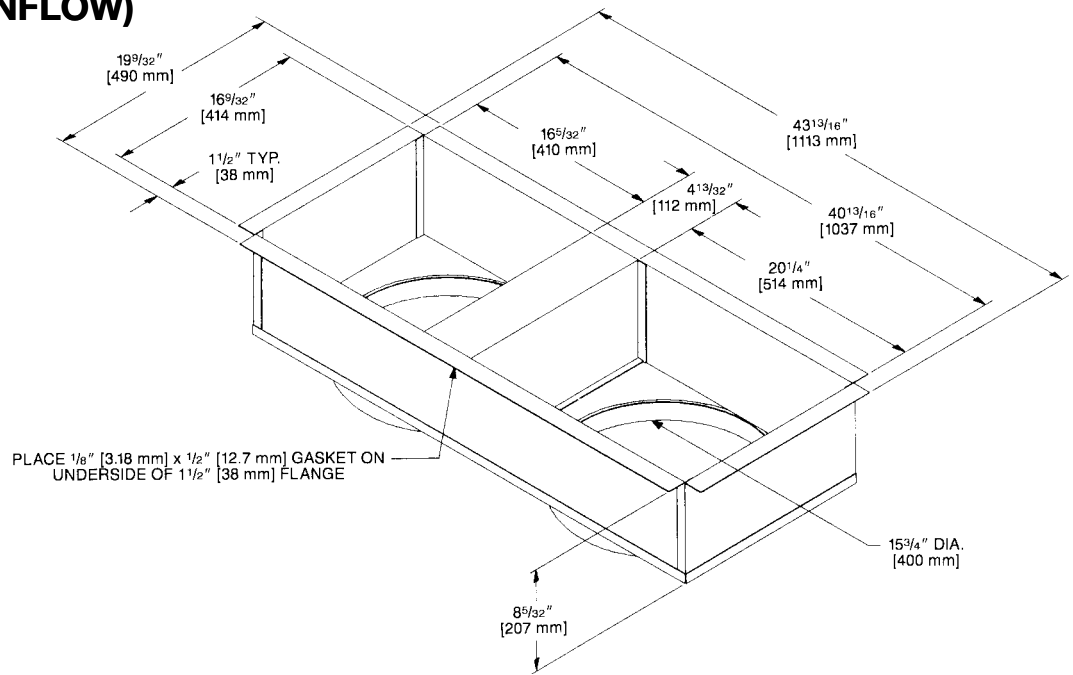

[] Designates Metric Conversions

DUCT ADAPTERS RECTANGULAR TO ROUND TRANSITIONS (DOWNFLOW) (con't.)

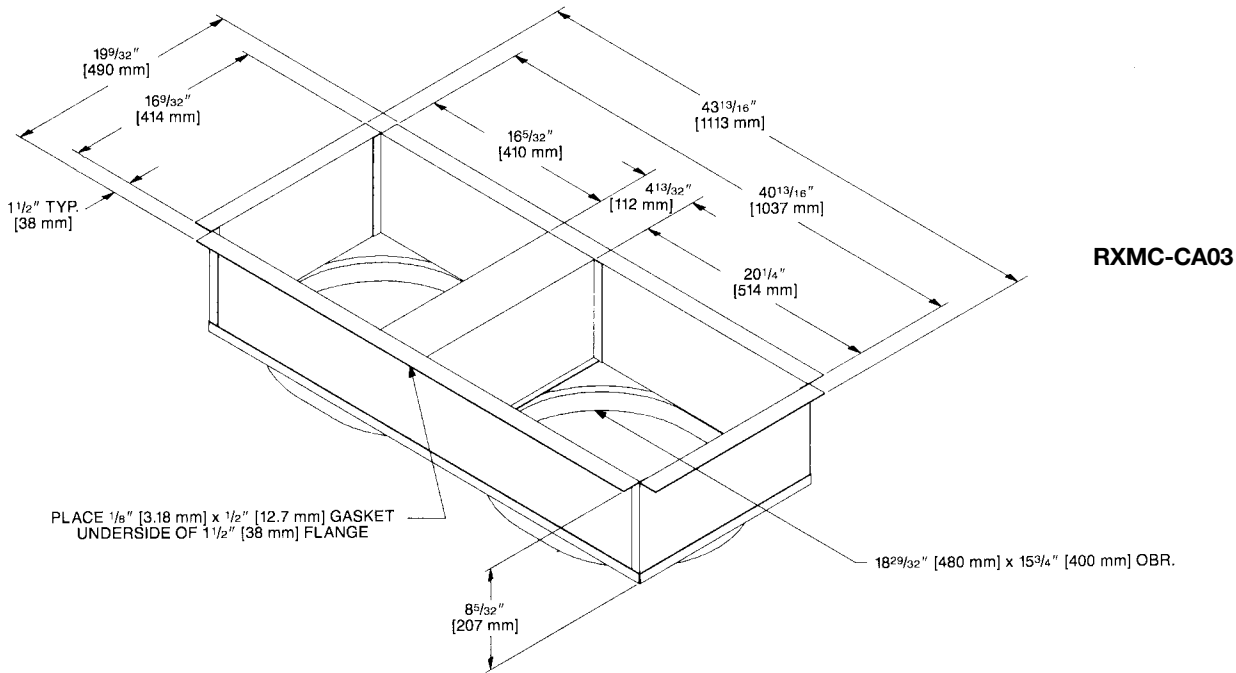

[] Designates Metric Conversions

FRESH AIR DAMPER FOR USE ON RQPW- SERIES

AXRF-FAA1 (Fixed - 0-35%)

The 0-35% manual outside Air Damper is designed to replace the unit return air duct cover. No drilling or damper assembly is required. The amount of outside air (0-35%) is controlled by simply adjusting the side damper.

AXRF-FAB1 (Motorized - 0-35%)

The 0-35% motorized outside Air Damper is designed to replace the unit return air duct cover. No drilling or damper assembly is required. The control motor opens the adjustable slide damper when the unit blower motor is energized.

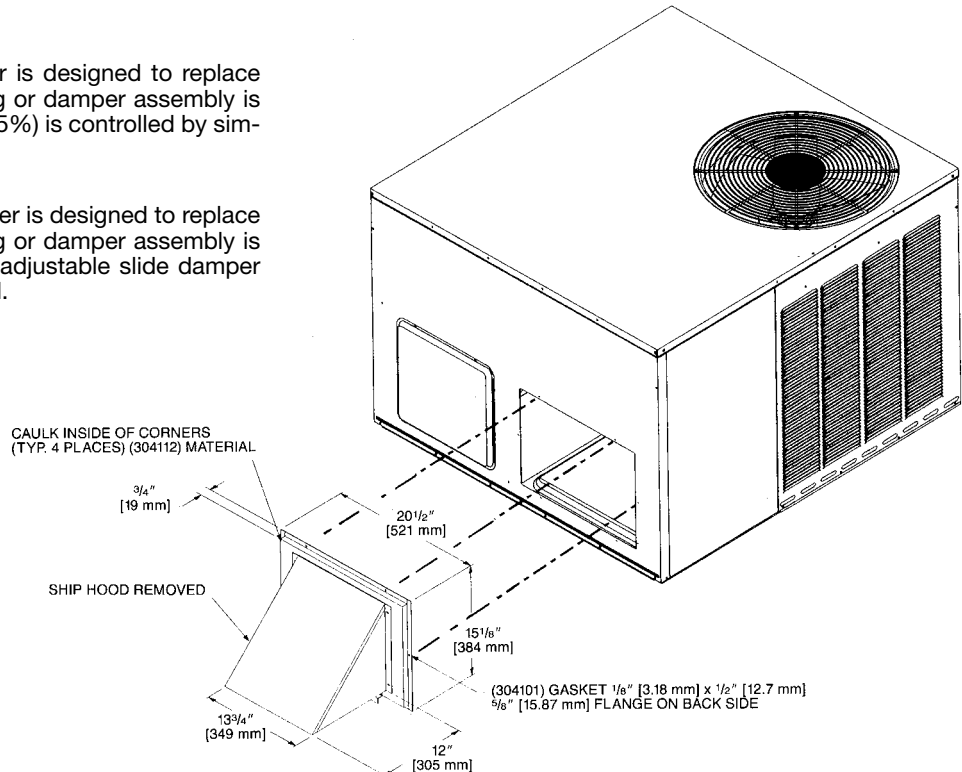

ECONOMIZERS

AXRE-CAA30 (3 Position) and AXRD-CAM10 (Fully Modulating) for RQPW- SERIES

AXRE-CAA30 (3 Position)

Provided with enthalpy control, and mixed air sensor. Settings include fully open, fully closed and adjustable mid point.

AXRD-CAM10 (Fully Modulating)

Provided with enthalpy control, mixed air sensor and minimum position potentiometer for proportioning (modulating) the amount of fresh air.

NOTE: See economizer installation instructions for correct filter access door.

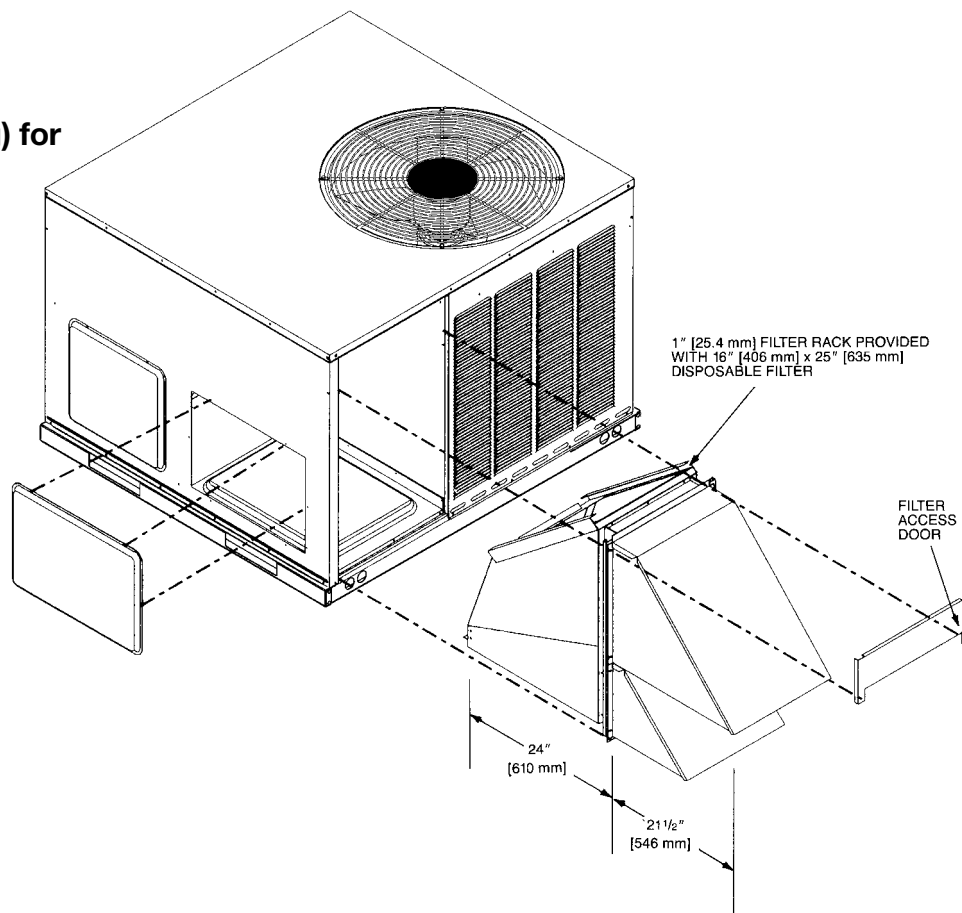

ECONOMIZERS

AXRD-CCM10 (Fully Modulating) and RXRE-CCA30 (3 Position) Horizontal Application

AXRD-CCM10 (Fully Modulating)

Provided with enthalpy control, mixed air sensor and minimum position potentiometer for proportioning (modulating) the amount of fresh air.

AXRE-CCA30 (3-Position)

Has outdoor air sensor, minimum position potentiometer and mixed air sensor to provide three damper positions.

[] Designates Metric Conversions

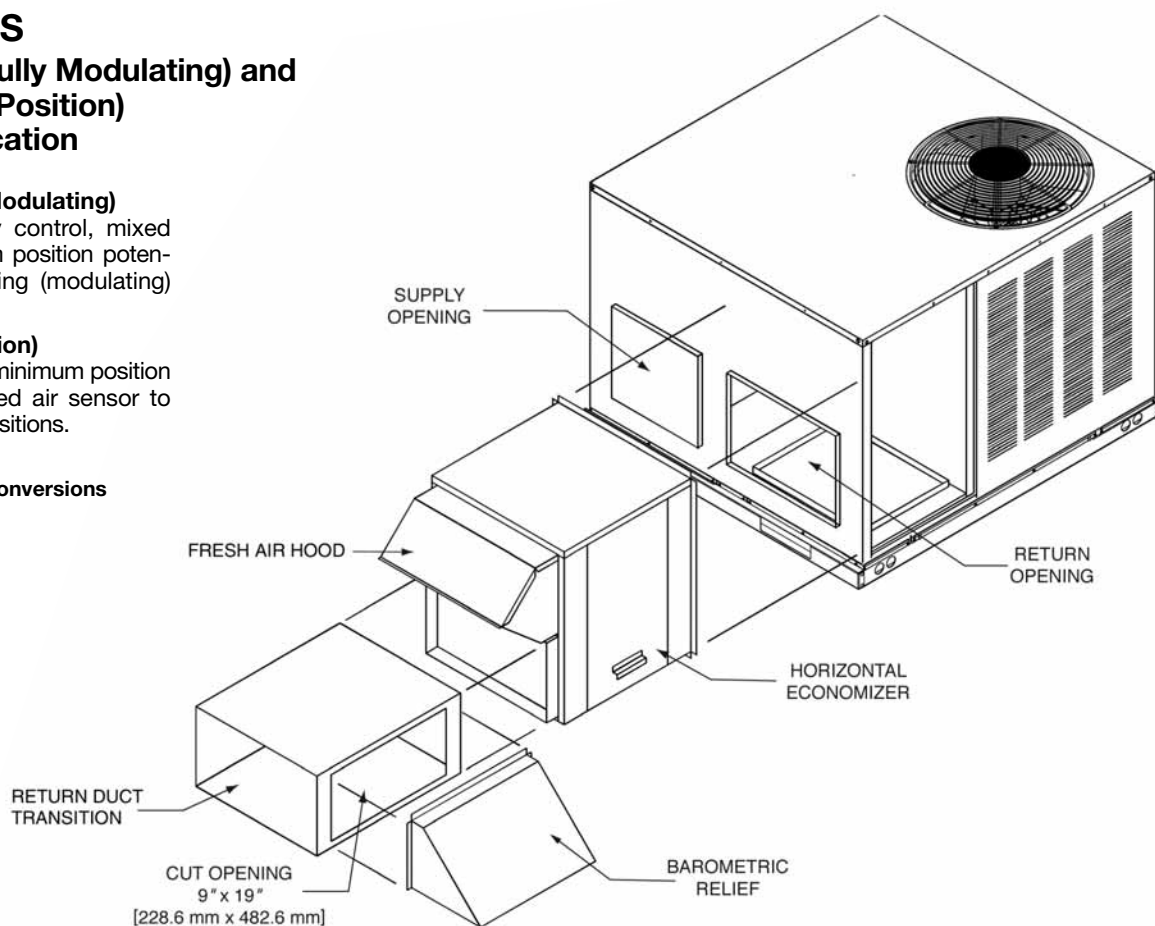

FILTER KIT INSTALLATION

RXRY-01

For use in either vertical or horizontal discharge.

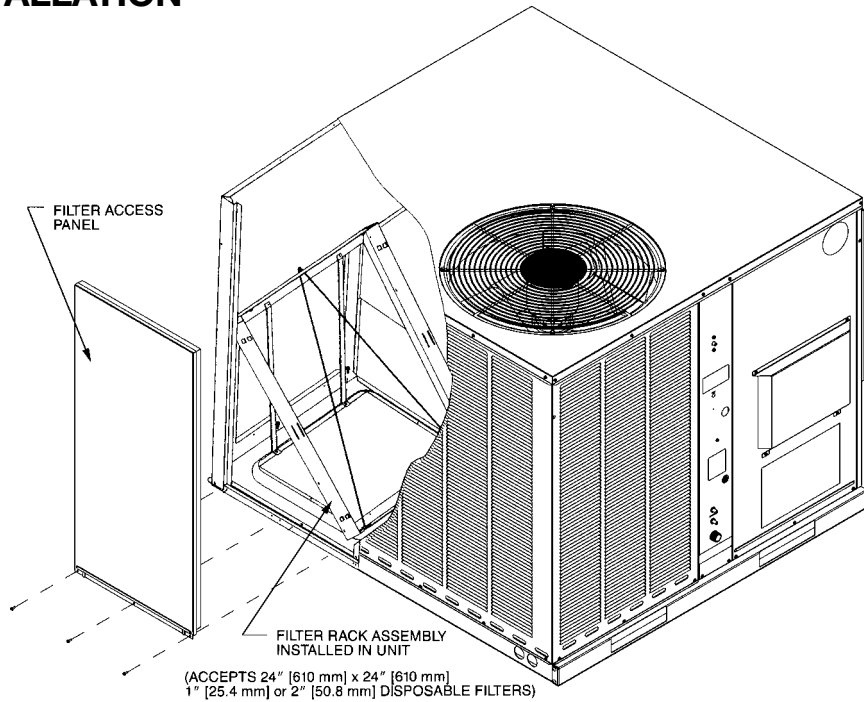

Airflow Pressure Drop, Inches W.C. [kPa]		
CFM [L/s]	1" Filter	2" Filter
500 [236]	.02 [.0050]	.03 [.0075]
600 [283]	.02 [.0050]	.03 [.0075]
700 [330]	.03 [.0075]	.04 [.0101]
800 [378]	.04 [.0101]	.05 [.0124]
900 [425]	.05 [.0124]	.06 [.0149]
1000 [472]	.07 [.0174]	.08 [.0199]
1100 [519]	.08 [.0199]	.09 [.0224]
1200 [566]	.10 [.0249]	.12 [.0299]
1300 [614]	.13 [.0324]	.15 [.0373]
1400 [661]	.16 [.0398]	.19 [.0473]
1500 [708]	.19 [.0473]	.21 [.0523]
1600 [755]	.20 [.0498]	.23 [.0572]
1700 [802]	.21 [.0523]	.24 [.0598]
1800 [850]	.22 [.0548]	.25 [.0623]
1900 [897]	.24 [.0598]	.27 [.0672]
2000 [944]	.26 [.0647]	.29 [.0722]

[] Designates Metric Conversions

DUCT ADAPTER SIDEFLOW SQUARE TO ROUND TRANSITION AXMC-BA01

Adapts the side rectangular supply and return openings to 14" [356 mm] diameter round openings. Adapters provided with same finish as unit and also provided with thermal insulation.

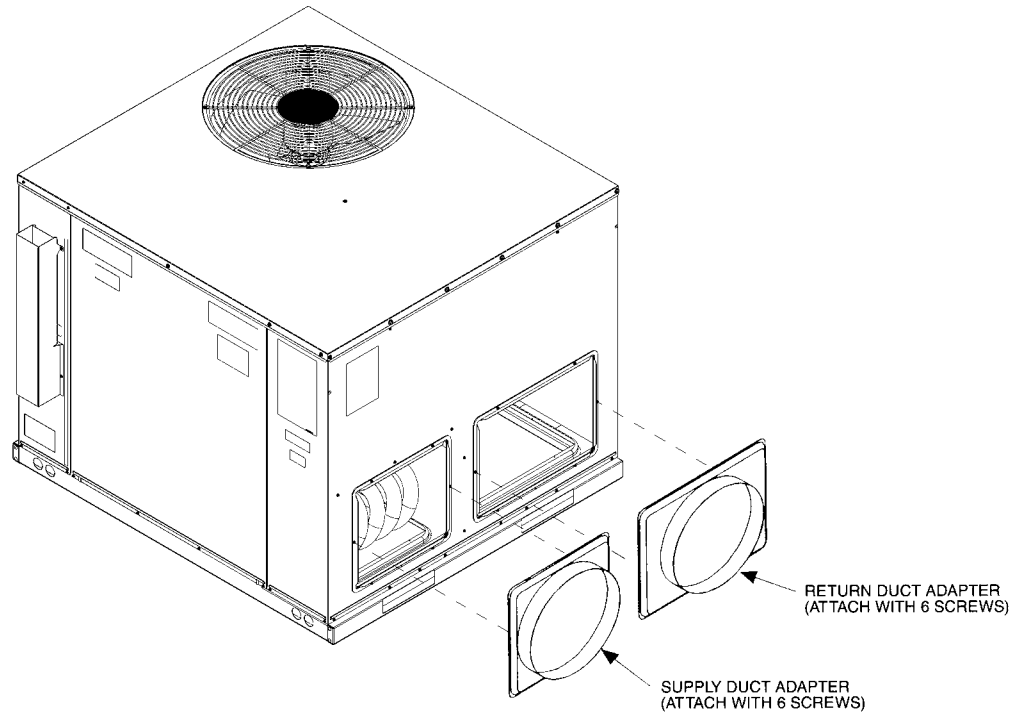

[] Designates Metric Conversions

Roofcurb (Sloped) RXQG-AAA14 & RXQG-AAA24 for RQPW- SERIES

Dual fuel models must use sloped curbs.

Hinged corners make for fast, easy set-up.

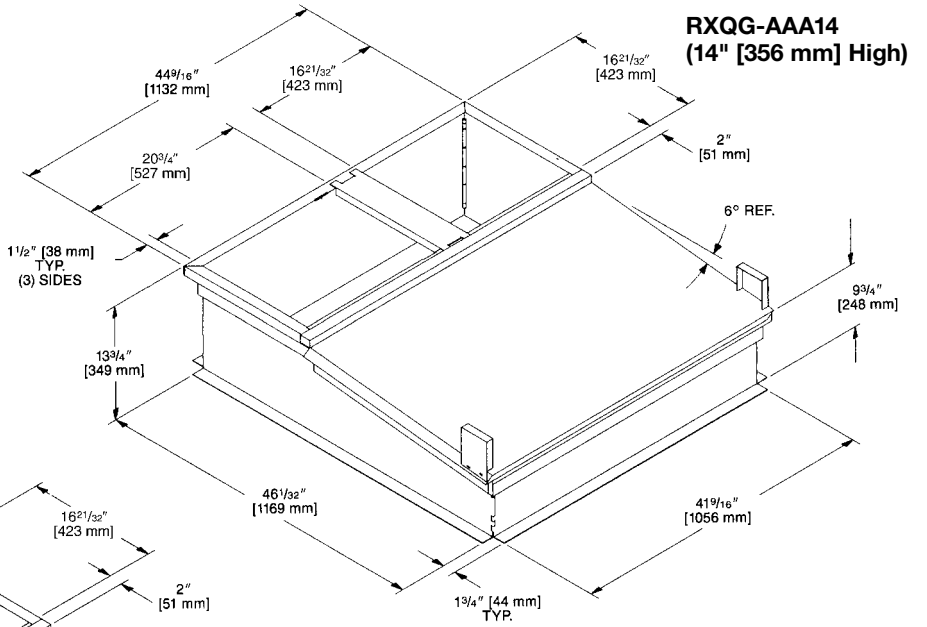

RXQG-AAA24 (24" [610 mm] High)

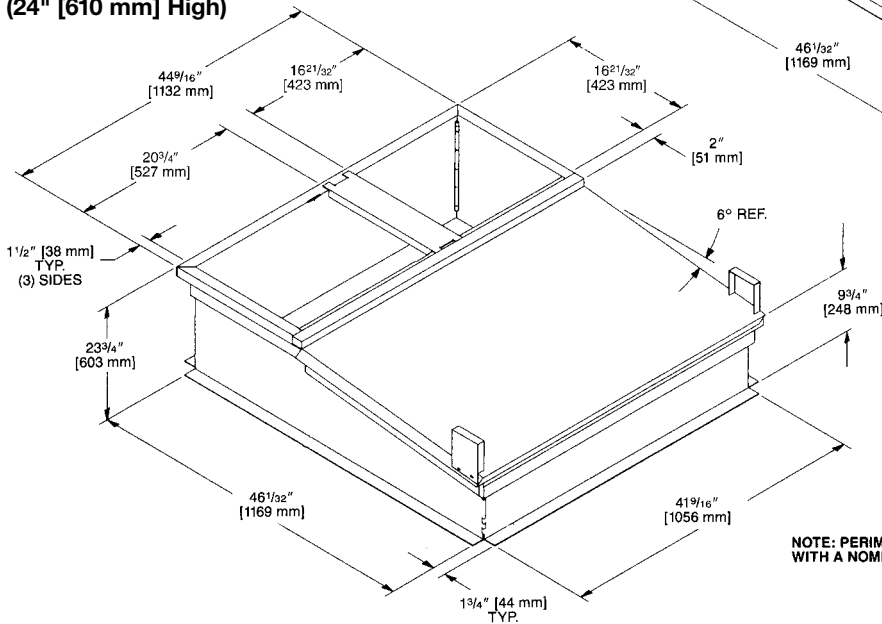

NOTE: PERIMETER OF ROOFCURB IS SUPPLIED WITH A NOMINAL 1" [25.4 mm] x 4" [102 mm] PINE NAILING STRIP.

PACKAGE DUAL FUEL ROOFCURB INSTALLATION (SLOPED)

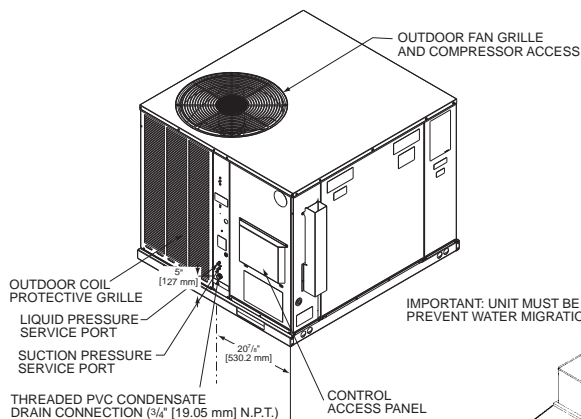

IMPORTANT: UNIT MUST BE LEVEL TO PREVENT WATER MIGRATION

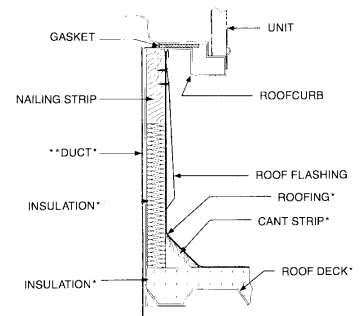
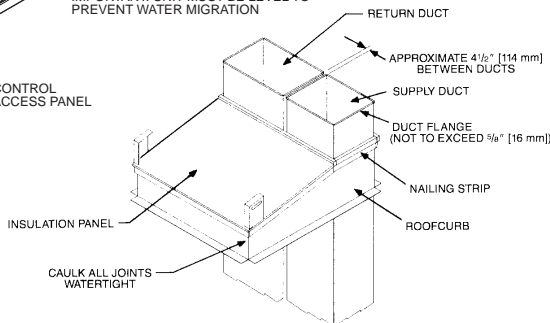

*BY CONTRACTOR
**FOR INSTALLATION OF DUCT AS SHOWN, USE RECOMMENDED DUCT SIZES FROM ROOFCURB INSTALLATION INSTRUCTIONS. FOR DUCT FLANGE AT ATTACHMENT TO UNIT, SEE UNIT INSTALLATION INSTRUCTIONS FOR RECOMMENDED DUCT SIZES.

[] Designates Metric Conversions

PACKAGE DUAL FUEL PACKAGE ROOFCURB INSTALLATION (Full Perimeter)

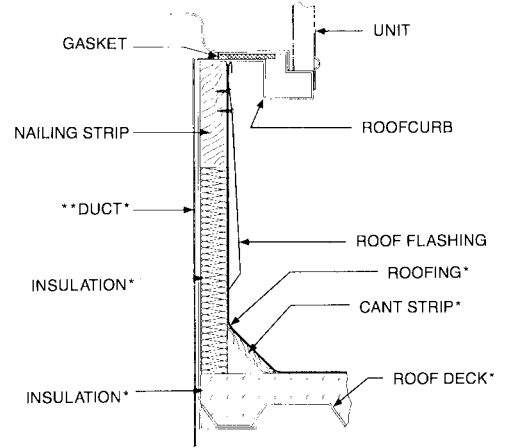
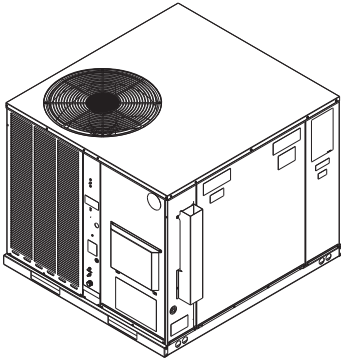

*BY CONTRACTOR
**FOR INSTALLATION OF DUCT AS SHOWN, USE RECOMMENDED DUCT SIZES FROM ROOFCURB INSTALLATION INSTRUCTIONS. FOR DUCT FLANGE AT ATTACHMENT TO UNIT, SEE UNIT INSTALLATION INSTRUCTIONS FOR RECOMMENDED DUCT SIZES.

ROOFCURB ADAPTERS

Fabricated from galvanized steel to adapt the New cabinet to the old style curb. All are furnished with a New gasket.

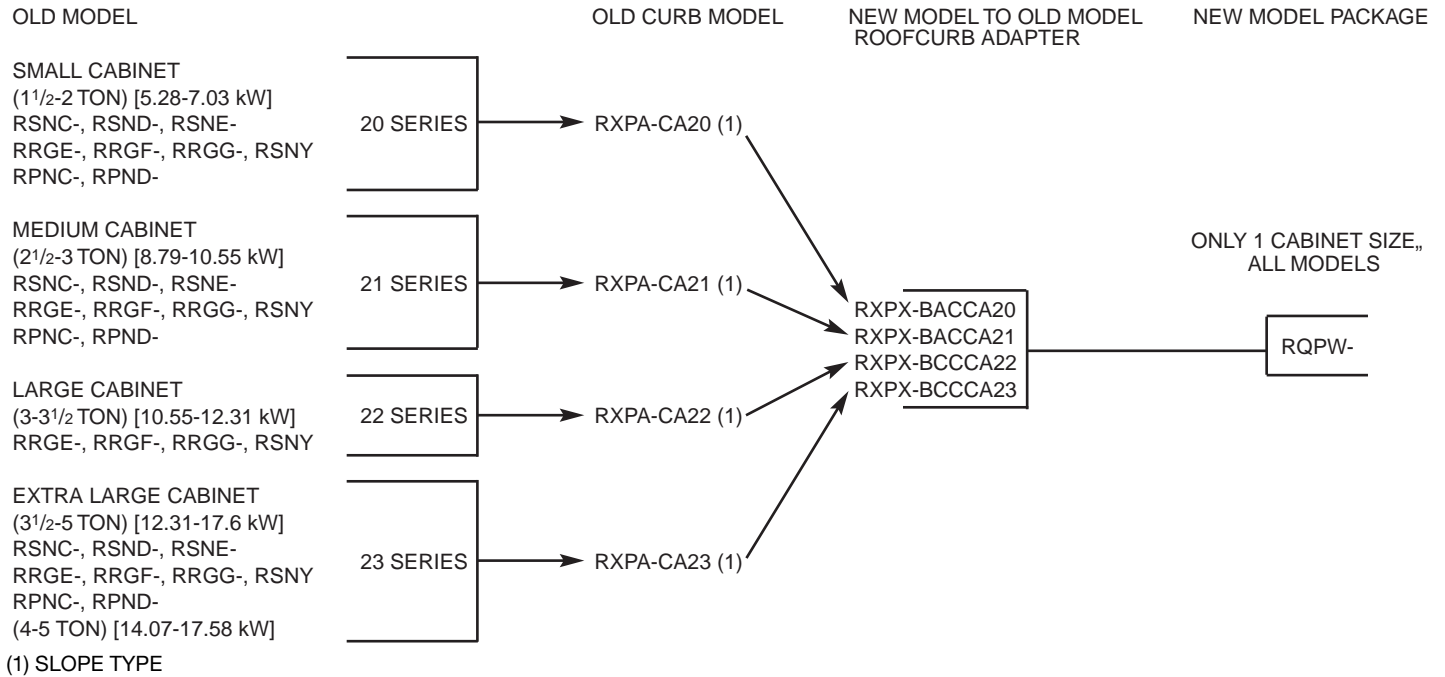

[] Designates Metric Conversions

LIFT KIT—MODEL NO. RXML-A01

The lift kit is intended for temporary installation while the unit is being lifted into position. Kit includes 4 lift brackets.

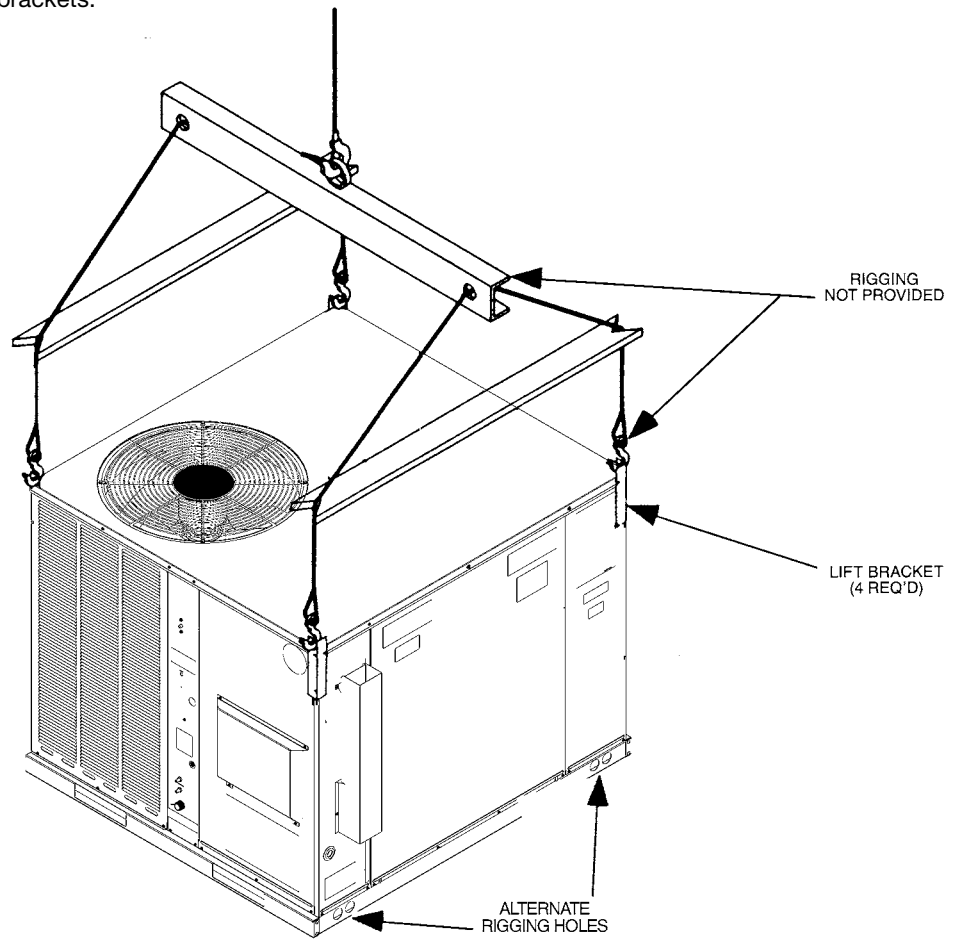

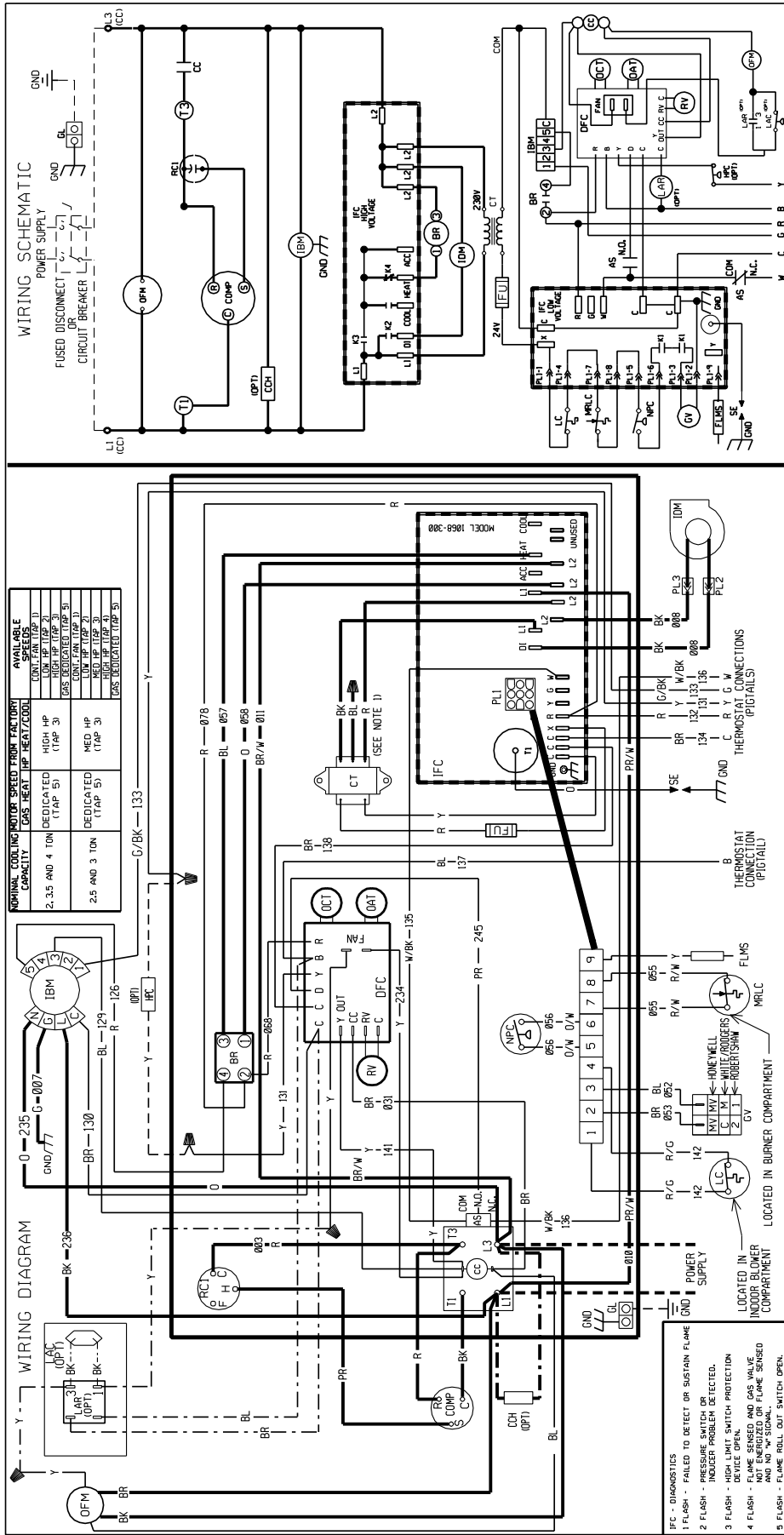

BEFORE PURCHASING THIS APPLIANCE, READ IMPORTANT ENERGY COST AND EFFICIENCY INFORMATION.
RETAILER.

GENERAL TERMS OF LIMITED WARRANTY*

Rheem will furnish a replacement for any part of this product which fails in normal use and service within the applicable periods stated, in accordance with the terms of the limited warranty.

***For complete details of the Limited and Conditional Warranties, including applicable terms and conditions, contact your local contractor or the Manufacturer for a copy of the product warranty certificate.**

Conditional Parts (Registration Required)

- 1 Phase, Residential ApplicationsTen (10) Years
- Compressor**
- 1 Phase, Residential Applications.....Ten (10) Years
- Stainless Steel Heat Exchanger**
- 1 Phase, Residential ApplicationLimited Lifetime



The new degree of comfort.[®]

In keeping with its policy of continuous progress and product improvement, Rheem reserves the right to make changes without ~~notice~~.

Rheem Heating, Cooling & Water Heating • P.O. Box 17010
Fort Smith, Arkansas 72917 • www.rheem.com

Rheem Canada Ltd./Ltée • 125 Edgeware Road, Unit 1
Brampton, Ontario • L6Y 0P5



INTEGRATED AIR & WATER

PRINTED IN U.S.A 03/12 QG FORM NO. D11-002