

**Commercial
High-Efficiency
Remote Heat Pumps
RPWL- 090 & 120 Series**



Featuring Industry Standard R-410A



**7.5 TON MODEL
[26 kW]**

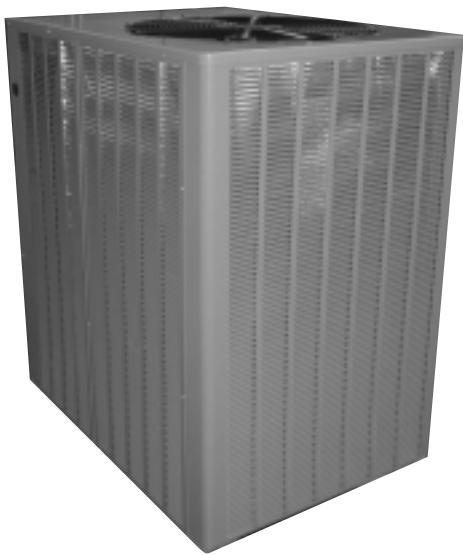

**10 TON MODEL
[35 kW]**



**7.5 & 10 NOMINAL TON UNITS
[26 & 35 kW]**



TABLE OF CONTENTS

Model Number Designation.....	2	Airflow Correction Factors.....	11-12
Accessories	2	Piping	13-14
Standard Unit Features	3-6	General Installation	15
Performance Ratings	7	Typical Field Wiring Connections	16
Electrical & Physical Data Table.....	7	Wiring Schematics.....	17-18
Unit Dimensions.....	8-9	Sequence of Operation.....	19
Selection Procedure	10	Guide Specifications	20
Cooling & Heating Performance Data	11-12	Limited Warranty	20

WHY USE A HIGH EFFICIENCY, AIR COOLED REMOTE HEAT PUMP SYSTEM?

- The size ranges offered by Rheem® allow you to mix or match components to meet actual job requirements, thus eliminating the need to use oversized or undersized equipment. Equipment sized to meet the actual load will provide better operating economy, better humidity control, and longer equipment life.
- With an air cooled system, you have no water or sewer connections to make, and no troublesome and costly water treatment problems.
- Since the Remote Heat Pump unit is located outside the building, and the low profile air handling unit can be installed in the drop ceiling or in the conditioned space, you will not need a separate equipment room which takes up valuable building space.
- Remote mounting of the already quiet heat pump unit keeps the compressor and condenser fan noise outside, and the vertical discharge fans carry the sound up and away from the surrounding area.
- Because of the simple design of the Rheem Remote Heat Pump unit, installation is quick and simple, and very little maintenance is required.
- Energy Efficiency Ratings (EER's) to 11.0!

[] Designates Metric Conversions

MODEL NUMBER DESIGNATION

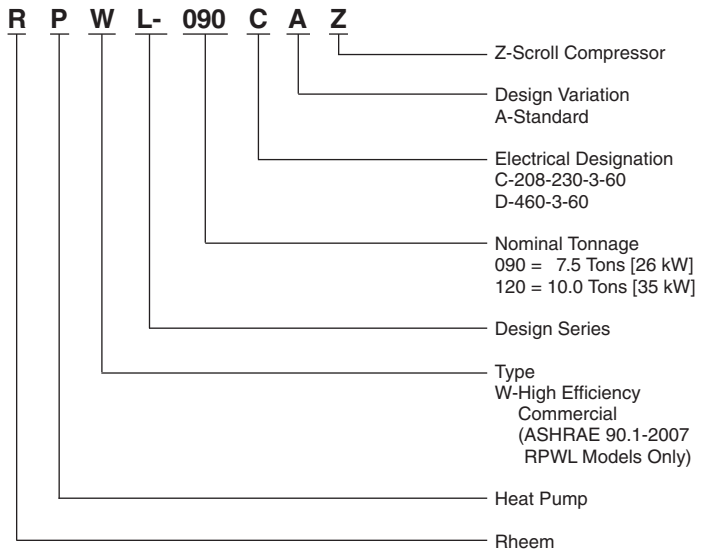

FIELD-INSTALLED HEAT PUMP UNIT ACCESSORIES

ACCESSORY DESCRIPTION	MODEL NUMBER
Sight Glass	RXAG-A048
Outdoor Thermostat	RXPT-A01

STANDARD UNIT FEATURES

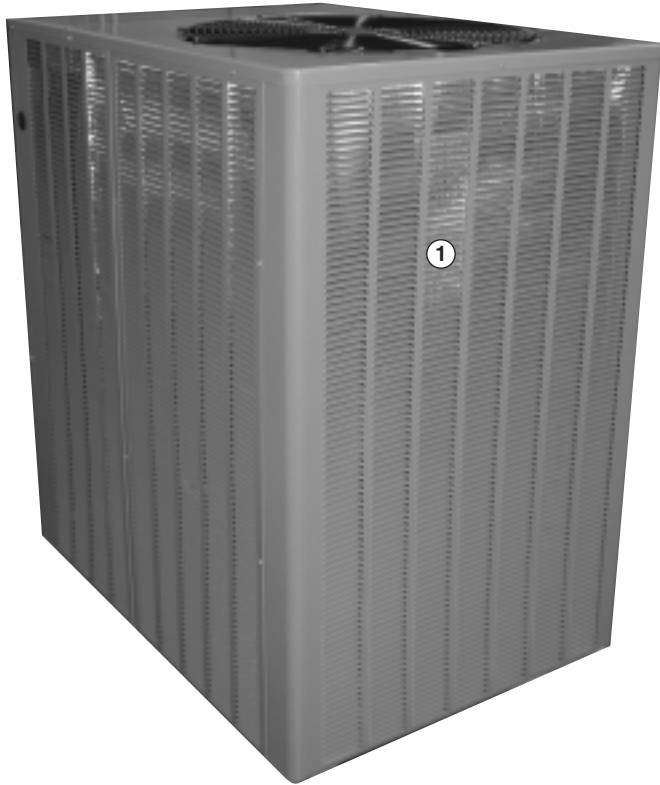

7.5 TON FEATURES AND BENEFITS

1. **CABINET**—Galvanized steel with powder coat paint finish. The powder coat paint finish is high gloss, durable and capable of withstanding a 1000-hour salt spray test per ASTM B 117. All access panels can be opened or removed without affecting the structural strength of the unit. Stamped louvered panels offer 100% protection for the condenser coil.
2. **EQUIPMENT GROUND**—Lug for field connection of ground wire.
3. **CONTACTOR**—The contactor is an electrical switch which operates the compressor and outdoor fans. Its 24 volt coil is activated on a call for cooling or heating.

CONTROL BOX

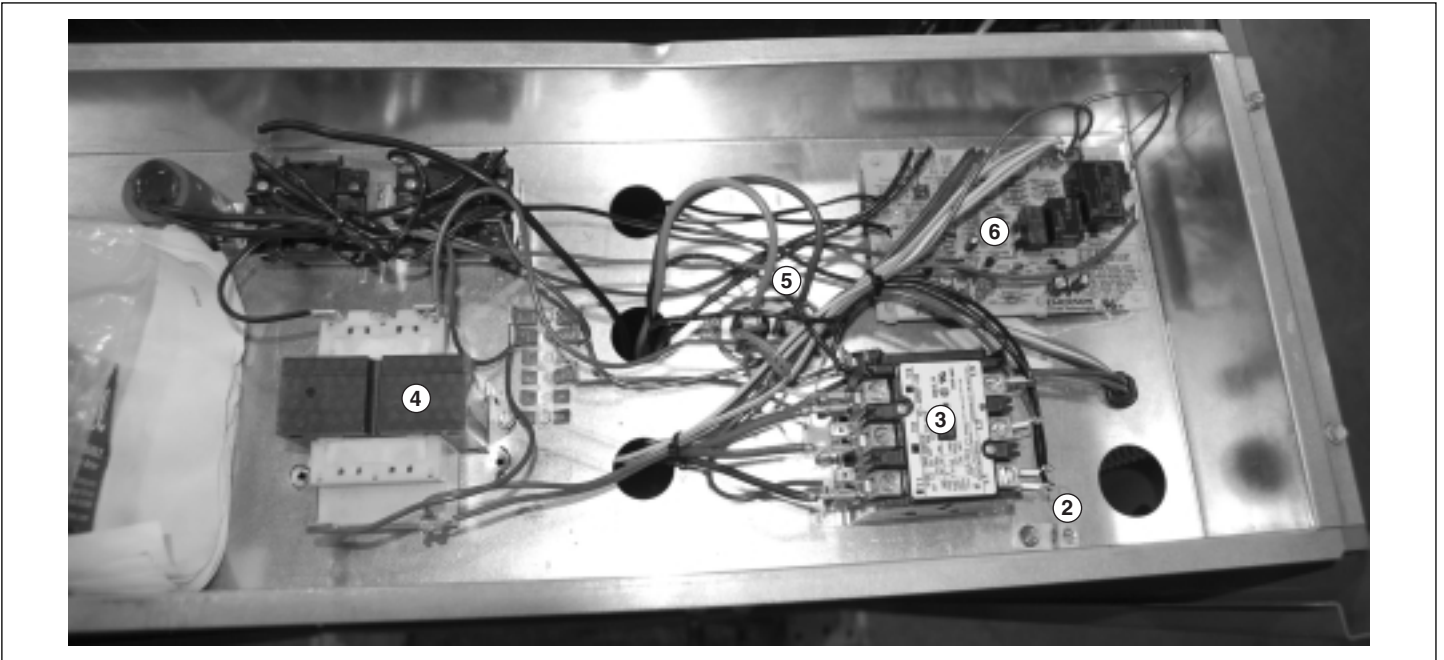

4. **TRANSFORMER**—75 VA step-down type, from Line to 24 volts with resettable circuit breaker.
5. **CAPACITOR**—Help provide starting torque necessary to boost the condenser fan motors to operating speed by directing their stored energy to the starter winding in step with the running winding.
6. **DEMAND DEFROST CONTROL**—Used when unit is in heating mode to defrost outdoor coil.
7. **AUTO-RESET HIGH PRESSURE CONTROL, AND AUTO-RESET LOW PRESSURE CONTROL**—To provide compressor protection under abnormally high head pressure conditions (outdoor fan failure, restriction, dirty coil, etc.) or abnormally low suction pressure conditions (restrictions, TEV failure, loss of charge, indoor blower failure, etc.) while eliminating nuisance tripping sometimes experienced with conventional control systems.

STANDARD UNIT FEATURES (con't.)

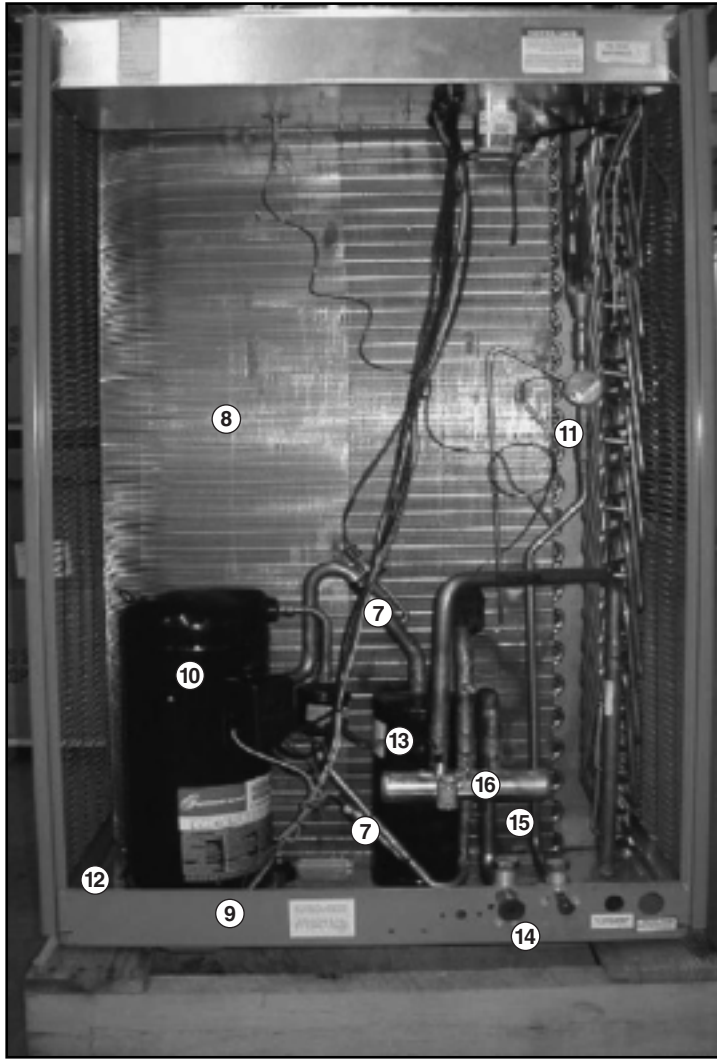

8. COIL—Constructed with copper tubes and aluminum fins mechanically bonded to tubes for maximum heat transfer capabilities. All coil assemblies are leak tested up to 550 PSIG (3792 kPa) internal pressure.

SERVICE ACCESS—Control box with separate line and control voltages, as well as compressor and other refrigerant controls are accessible through access panels. An electrical access cover may be opened or removed without affecting normal operation of the unit. Condenser fan motors are equipped with molded plugs for easy removal. Louver panels and end access panel can be removed for coil cleaning.

9. BASE PAN—Galvanized steel with powder coat paint finish.

10. COMPRESSOR—The Scroll Compressor is hermetically sealed with internal high temperature protection, and durable insulation on motor windings. The entire compressor is mounted on rubber grommets to reduce vibration and noise.

11. TX VALVE—Used when unit is in heating mode and outdoor coil functions as evaporator.

12. CRANKCASE HEATER—Minimizes refrigerant migration to compressor sump.

13. SUCTION LINE ACCUMULATOR—To prevent liquid slugging of compressor.

14. REFRIGERANT CONNECTIONS—All field sweat joints are made external of the unit and are located close to the ground for a neat looking installation.

15. SERVICE VALVES—Standard on liquid line and vapor line.

16. REVERSING VALVE—Sized for maximum capacity and efficiency, 24V coil, energized in heating.

STANDARD UNIT FEATURES (con't.)

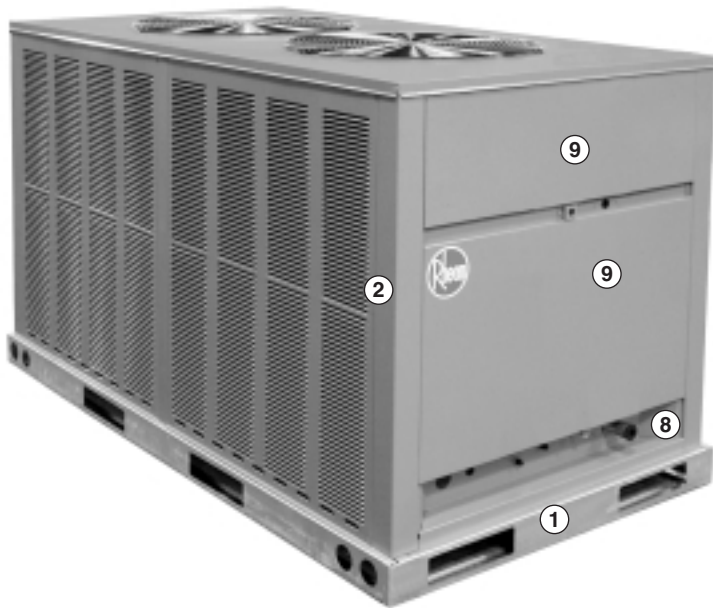

10 TON FEATURES AND BENEFITS

- 1. BASE RAILS**—Commercial grade base rails for handling any rigging.
- 2. CABINET**—Galvanized steel with powder coat paint finish. The powder coat paint finish is high gloss, durable and capable of withstanding a 1000-hour salt spray test per ASTM B 117. All access panels can be opened or removed without affecting the structural strength of the unit. Stamped louvered panels offer 100% protection for the condenser coil.

CONTROL BOX

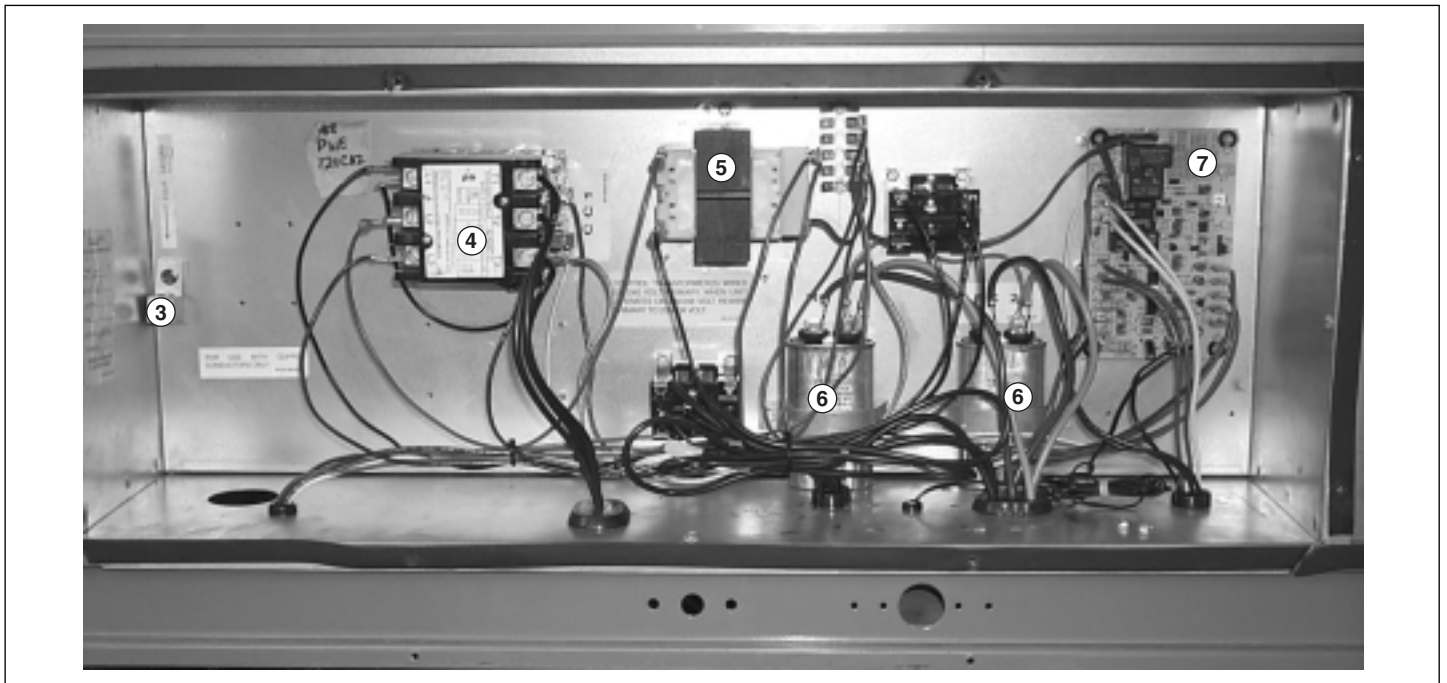

- 3. EQUIPMENT GROUND**—Lug for field connection of ground wire.
- 4. CONTACTOR**—The contactor is an electrical switch which operates the compressor and outdoor fans. Its 24 volt coil is activated on a call for cooling or heating.
- 5. TRANSFORMER**—75 VA step-down type, from Line to 24 volts with resettable circuit breaker.
- 6. CAPACITORS**—Help provide starting torque necessary to boost the condenser fan motors to operating speed by directing their stored energy to the starter winding in step with the running winding.
- 7. DEMAND DEFROST CONTROL**—Used when unit is in heating mode to defrost outdoor coil.
- 8. COILS**—Constructed with copper tubes and aluminum fins mechanically bonded to tubes for maximum heat transfer capabilities. All coil assemblies are leak tested up to 550 PSIG [3792 kPa] internal pressure.

[] Designates Metric Conversions

STANDARD UNIT FEATURES (con't.)

UNIT INTERIOR-TOP VIEW

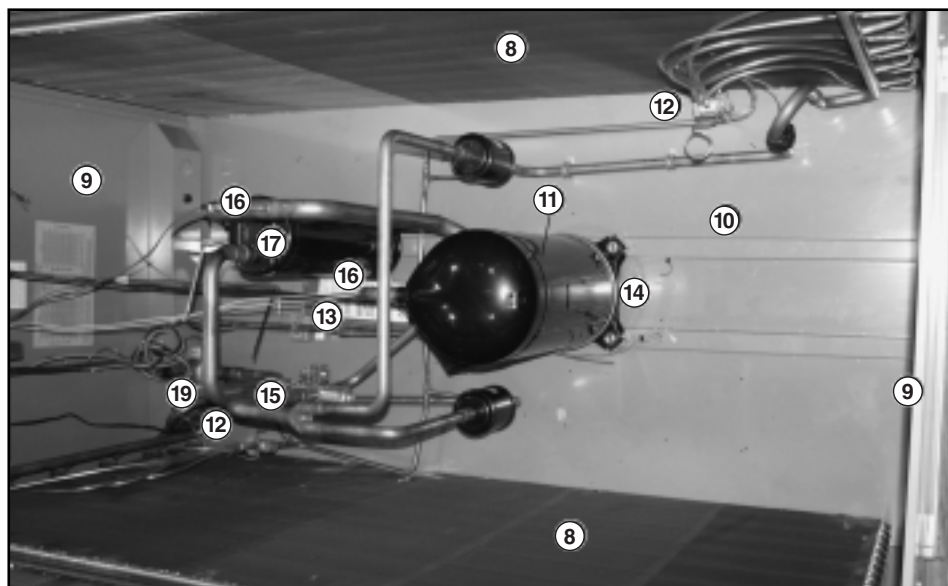

- 9. SERVICE ACCESS**—Control box with separate line and control voltages, as well as compressor and other refrigerant controls are accessible through access panels. An electrical access cover may be opened or removed without affecting normal operation of the unit. Condenser fan motors are equipped with molded plugs for easy removal. Louver panels and end access panel can be removed for coil cleaning.
- 10. BASE PAN**—Galvanized steel with powder coat paint finish.
- 11. COMPRESSOR**—The Scroll Compressor is hermetically sealed with internal high temperature protection, and durable insulation on motor windings. The entire compressor is mounted on rubber grommets to reduce vibration and noise.
- 12. TX VALVE**—Used when unit is in heating mode and outdoor coil functions as evaporator.
- 13. FILTER DRIER**—Field installed in liquid line.
- 14. CRANKCASE HEATER**—Minimizes refrigerant migration to compressor sump.
- 15. REVERSING VALVE**—Sized for maximum capacity and efficiency, 24V coil, energized in heating.
- 16. AUTO-RESET HIGH PRESSURE CONTROL, AND AUTO-RESET LOW PRESSURE CONTROL**—To provide compressor protection under abnormally high head pressure conditions (outdoor fan failure, restriction, dirty coil, etc.) or abnormally low suction pressure conditions (restrictions, TEV failure, loss of charge, indoor blower failure, etc.) while eliminating nuisance tripping sometimes experienced with conventional control systems.
- 17. SUCTION LINE ACCUMULATOR**—To prevent liquid slugging of compressor.
- 18. REFRIGERANT CONNECTIONS**—All field sweat joints are made external of the unit and are located close to the ground for a neat looking installation.
- 19. SERVICE VALVE**—Standard on liquid line, and vapor line.



CONDENSER FAN MOTORS—Direct drive, single-phase permanently lubricated “PSC” motors with inherent overload protection.

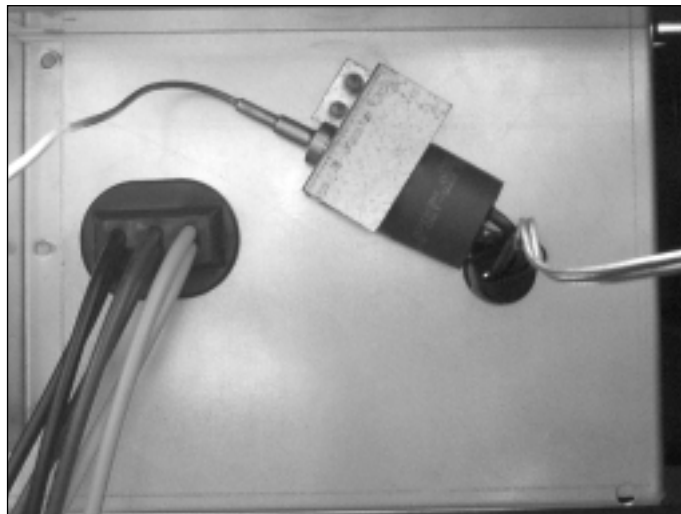

LOW AMBIENT CONTROL—A pressure sensitive fan cycling control allows cooling operation of unit down to 0°F [-18°C].

[] Designates Metric Conversions

Performance Data AHRI Standard Conditions

Note: Only these combinations of indoor/outdoor units are approved and any other combinations should not be used.

Model Numbers		AHRI Cooling Performance						AHRI Htg. Performance (70°F [21.0°C] Indoor)			
		80°F [26.5°C] DB/67°F [19.5°C] WB Indoor Air 95°F [35.0°C] DB Outdoor Air						Outdoor Air 47°F DB/43°F WB [8.5°C/6.0°C] DOE High Temp.		Outdoor Air 17°F DB/15°F WB [-8.5°C/-9.5°C] DOE Low Temp.	
Outdoor Unit RPWL-	Indoor Coil and/or Air Handler	Total Capacity BTU/H [kW]	Net Sensible BTU/H [kW]	Net Latent BTU/H [kW]	EER	Sound Rating dB	Indoor CFM [L/s]	BTU/H [kW]	COP	BTU/H [kW]	COP
Rev. 6/3/09 090CAZ	RHGM-090Z ①	86,000 [25.2]	67,400 [19.7]	18,600 [5.4]	11.00	82	3,000 [1416]	90,000 [26.4]	3.30	55,000 [16.1]	2.20
	RHGM-090ZK	86,000 [25.2]	67,400 [19.7]	18,600 [5.4]	11.00	82	3,000 [1416]	90,000 [26.4]	3.30	55,000 [16.1]	2.20
	RHGM-090ZL	86,000 [25.2]	67,400 [19.7]	18,600 [5.4]	11.00	82	3,000 [1416]	90,000 [26.4]	3.30	55,000 [16.1]	2.20
	RHGM-090ZM	86,000 [25.2]	67,400 [19.7]	18,600 [5.4]	11.00	82	3,000 [1416]	90,000 [26.4]	3.30	55,000 [16.1]	2.20
090DAZ	RHGM-090Z ①	86,000 [25.2]	67,400 [19.7]	18,600 [5.4]	11.00	82	3,000 [1416]	90,000 [26.4]	3.30	55,000 [16.1]	2.20
	RHGM-090ZK	86,000 [25.2]	67,400 [19.7]	18,600 [5.4]	11.00	82	3,000 [1416]	90,000 [26.4]	3.30	55,000 [16.1]	2.20
	RHGM-090ZL	86,000 [25.2]	67,400 [19.7]	18,600 [5.4]	11.00	82	3,000 [1416]	90,000 [26.4]	3.30	55,000 [16.1]	2.20
	RHGM-090ZM	86,000 [25.2]	67,400 [19.7]	18,600 [5.4]	11.00	82	3,000 [1416]	90,000 [26.4]	3.30	55,000 [16.1]	2.20
120CAZ	RHGM-120Z ①	116,000 [34.0]	87,100 [25.5]	28,900 [8.5]	11.00	88	3,750 [1770]	120,000 [35.2]	3.30	68,000 [19.9]	2.20
	RHGM-120ZK	116,000 [34.0]	87,100 [25.5]	28,900 [8.5]	11.00	88	3,750 [1770]	120,000 [35.2]	3.30	68,000 [19.9]	2.20
	RHGM-120ZL	116,000 [34.0]	87,100 [25.5]	28,900 [8.5]	11.00	88	3,750 [1770]	120,000 [35.2]	3.30	68,000 [19.9]	2.20
	RHGM-120ZM	116,000 [34.0]	87,100 [25.5]	28,900 [8.5]	11.00	88	3,750 [1770]	120,000 [35.2]	3.30	68,000 [19.9]	2.20
120DAZ	RHGM-120Z ①	116,000 [34.0]	87,100 [25.5]	28,900 [8.5]	11.00	88	3,750 [1770]	120,000 [35.2]	3.30	68,000 [19.9]	2.20
	RHGM-120ZK	116,000 [34.0]	87,100 [25.5]	28,900 [8.5]	11.00	88	3,750 [1770]	120,000 [35.2]	3.30	68,000 [19.9]	2.20
	RHGM-120ZL	116,000 [34.0]	87,100 [25.5]	28,900 [8.5]	11.00	88	3,750 [1770]	120,000 [35.2]	3.30	68,000 [19.9]	2.20
	RHGM-120ZM	116,000 [34.0]	87,100 [25.5]	28,900 [8.5]	11.00	88	3,750 [1770]	120,000 [35.2]	3.30	68,000 [19.9]	2.20

① Highest sales volume tested combination required by D.O.E. test procedures.

Electrical and Physical Data

Model Number RPWL-	ELECTRICAL							PHYSICAL					
	Phase Frequency (Hz) Voltage (Volts)	Compressor		Fan Motor Full Load Amperes (FLA)	Minimum Circuit Capacity Amperes	Fuse or HACR Circuit Breaker		Outdoor Coil			Refrig. Per Circuit Oz. [g]	Weight	
		Rated Load Amperes (RLA)	Locked Rotor Amperes (LRA)			Minimum Amperes	Maximum Amperes	Face Area Sq. Ft. [m²]	No. Rows	CFM [L/s]		Net Lbs. [kg]	Shipping Lbs. [kg]
Rev. 6/3/09													
090CAZ	3-60-208/230	25/25	190	4.2	36/36	45/45	60/60	34.50 [3.21]	2	5000 [2360]	372 [10546]	398 [181]	448 [203.2]
090DAZ	3-60-460	12.8	100	2.3	19	25	30	34.50 [3.21]	2	5000 [2360]	372 [10546]	398 [181]	448 [203.2]
120CAZ	3-60-208/230	30.1/30.1	225	4.8	43/43	50/50	70/70	32.88 [3.05]	2	7400 [3492]	436 [12361]	646 [293]	686 [311.2]
120DAZ	3-60-460	16.7	114	2.2	24	30	35	32.88 [3.05]	2	7400 [3492]	436 [12361]	646 [293]	686 [311.2]

[] Designates Metric Conversions

UNIT DIMENSIONS & WEIGHTS

7.5 TON [26.38 kW]

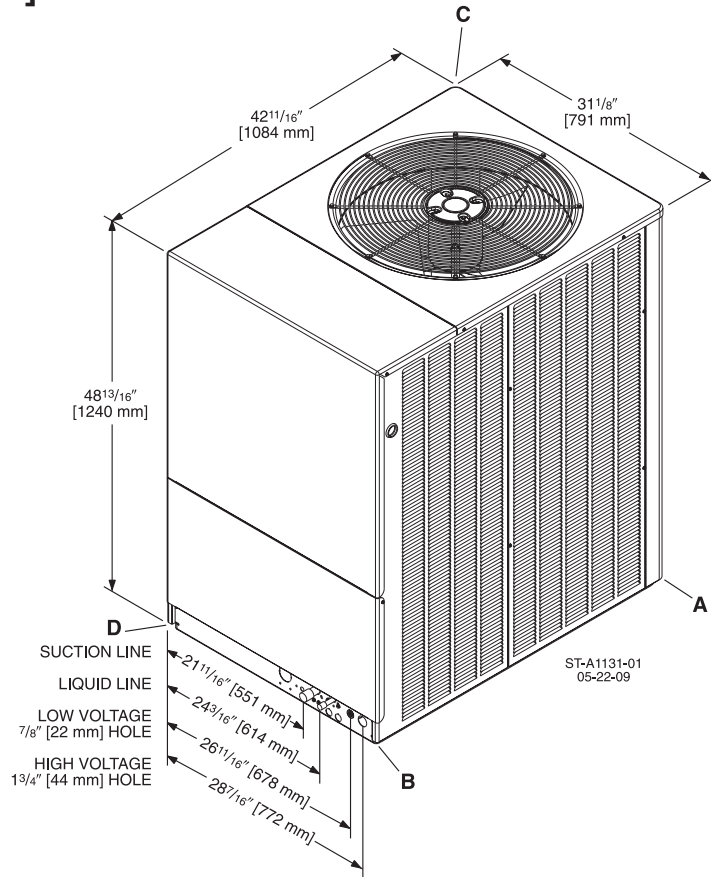

7.5 TON [26.38 kW]

CORNER WEIGHTS (LBS.) [kg]

MODEL	TOTAL WEIGHT LBS. [kg]	CORNER WEIGHTS, LBS. [kg]			
		A	B	C	D
RPWL-090	398 [180.5]	67 [30.4]	102 [46.3]	92 [41.7]	137 [62.1]

[] Designates Metric Conversions

UNIT DIMENSIONS (con't.) 10 TONS [35 kW]

CORNER WEIGHTS (PERCENTAGE)

MODEL	A	B	C	D
RPWL-120	26%	24%	26%	24%

CORNER WEIGHTS (LBS.) [kg]

MODEL	A	B	C	D
RPWL-120	167 [75.7]	160 [72.6]	160 [72.6]	167 [75.7]
TOTAL WEIGHT, 120 = 654 LBS. [296.6 kg]				

CENTER OF GRAVITY		
MODEL	X"	Y"
RPWL-120	31.2	18.9

[] Designates Metric Conversions

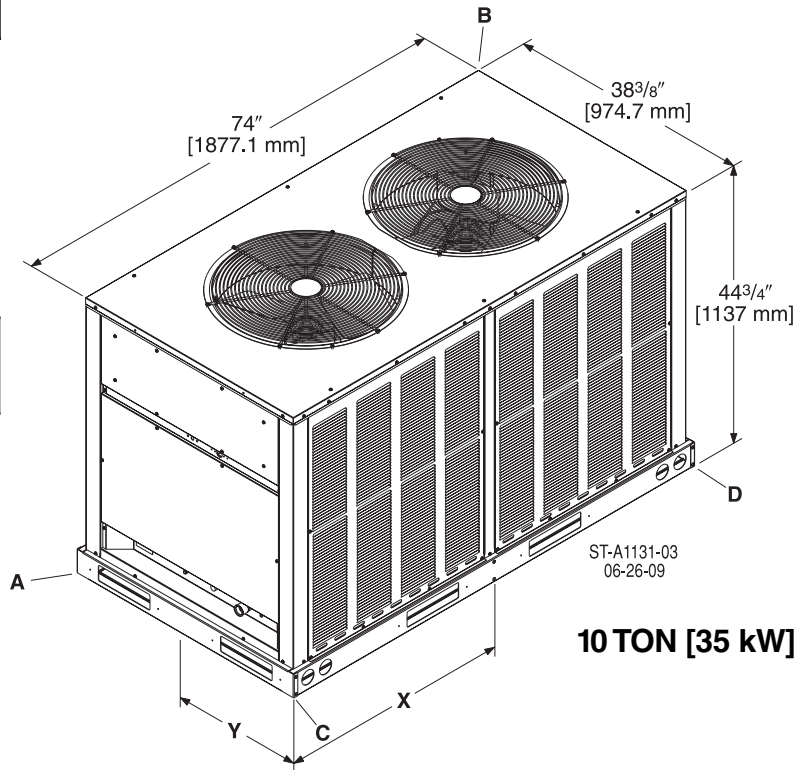

10 TON [35 kW]

10 TON [35 kW]

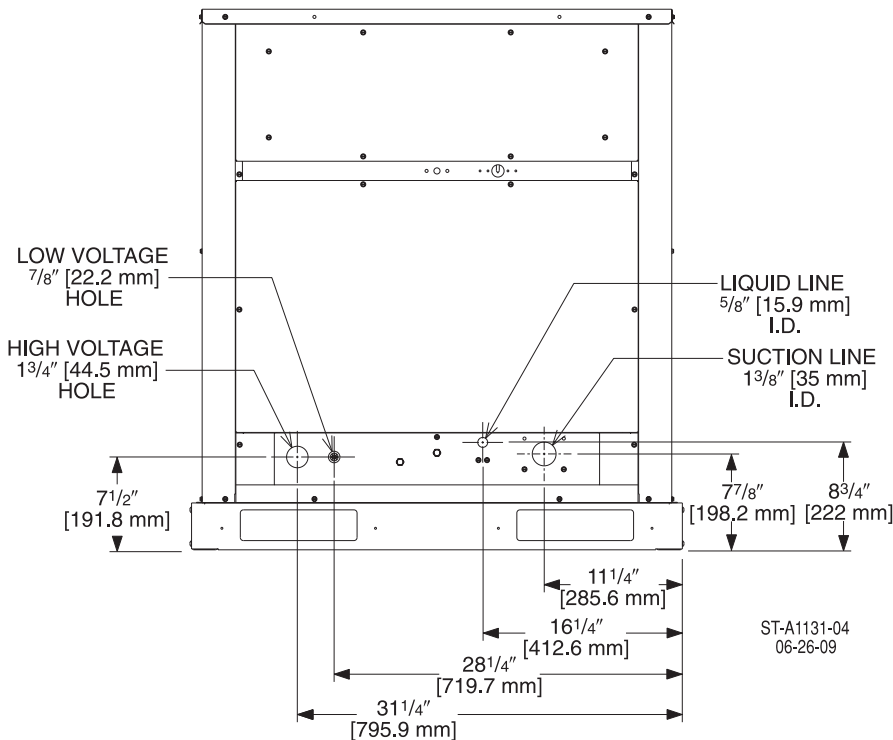

SELECTION PROCEDURE

To select an RPWL- Heat Pump unit to meet a job requirement, follow this procedure.

1. DETERMINE COOLING AND HEATING REQUIREMENTS AND SPECIFIC OPERATING CONDITIONS FROM PLANS AND SPECS.

Example: Total cooling capacity—	84,000 BTUH [24.61 kW]
Sensible cooling capacity—	68,000 BTUH [19.92 kW]
Heating capacity—	120,000 BTUH [35.16 kW]
*Condenser Entering Air—	95°F [35°C] DB
*Evaporator Mixed Air Entering	78°F [26°C] DB; 65°F [18°C] WB
*Indoor Air Flow (vertical)	3000 CFM [1416 L/s]
*External Static Pressure	.5 in. WG
Available Power	240 V, 3 PH

2. SELECT UNIT TO MEET COOLING REQUIREMENTS.

Since total cooling is within the range of a nominal 7.5 ton [26.4 kW] unit, enter cooling performance table at 95°F [35°C] DB condenser inlet air. Interpolate between 63°F [2°C] and 67°F [19°C] to determine total and sensible capacity and power input for 65°F [18°C] WB evap inlet air at 3200 CFM [1510 L/s] indoor air flow (table basis):

$$\begin{aligned}\text{Total Capacity} &= 85,150 \text{ BTUH [25.0 kW]} \\ \text{Sensible Capacity} &= 73,850 \text{ BTUH [23.0 kW]} \\ \text{Power Input (Compressor and Cond. Fans)} &= 6,750 \text{ Watts}\end{aligned}$$

Use formula in note ① on the cooling performance table to determine sensible capacity at 78°F [26°C] DB evaporator entering air:

$$\text{Sensible Capacity} = 67,250 \text{ BTUH [19.7 kW]}$$

3. CORRECT CAPACITIES OF STEP 2 FOR ACTUAL AIR FLOW.

Select factors from airflow correction table at 3000 CFM [1416 L/s] and apply to data obtained in step 2 to obtain gross capacity:

$$\begin{aligned}\text{Total Capacity} &= 85,450 \times .99 = 84,595 \text{ BTUH [24.8 kW]} \\ \text{Sensible Capacity} &= 73,850 \times .97 = 71,634 \text{ BTUH [21.0 kW]} \\ \text{Power Input} &= 6,750 \times 1.00 = 6,750 \text{ Watts}\end{aligned}$$

These are Gross Capacities, not corrected for blower motor heat or power.

4. DETERMINE BLOWER SPEED AND WATTS TO MEET SYSTEM DESIGN.

In the “Commercial Air Handler Specification Sheet” (Form #H11-514) follow the bold line example on the “Blower Performance Curve – 10 ton (wet coil)”. Enter the graph at 3000 CFM [1416 L/s]. Determine which “number of turns” line is closest to the intersection of 0.5 IN [.12 kPa] static and 3000 CFM [1416 L/s]. In this case 4 turns is the closest. Continue following the 3000 CFM line to the next intersection of 4 turns. From this intersection draw a line to the right to determine the watts.

$$\text{WATTS} = 950$$

5. CALCULATE INDOOR BLOWER BTUH HEAT EFFECT FROM MOTOR WATTS, STEP 4.

$$\text{HEAT} = 950 \times 3.412 = 3,240 \text{ BTUH}$$

6. CALCULATE NET COOLING CAPACITIES, EQUAL TO GROSS CAPACITY, STEP 3, MINUS INDOOR BLOWER MOTOR HEAT.

$$\begin{aligned}\text{Net Total Capacity} &= 85,430 - 3,240 = 82,190 \text{ BTUH [24.14 kW]} \\ \text{Net Sensible Capacity} &= 71,634 - 3,240 = 68,394 \text{ BTUH [20.00 kW]}\end{aligned}$$

7. CALCULATE UNIT INPUT AND JOB EER.

$$\text{Total Power Input} = 7,750 \text{ (step 3)} + 950 \text{ (step 4)} = 8,700 \text{ Watts}$$

$$\text{EER} = \frac{\text{Net Total BTUH [kW] (step 6)}}{\text{Power Input, Watts (above)}} = \frac{81,355}{7700} = 10.6$$

8. SELECT UNIT HEATING CAPACITY.

In the “Commercial Air Handler Specification Sheet” (Form #H11-514) turn to the “electrical heater kit characteristics table,” find a heater kit that is compatible with a 7.5 ton unit that has minimum of 120,000 BTUH. The RXHE-DE040CA [40 kW] has a capacity of 136,500 BTUH at 240 V.

*NOTE: These operating conditions are typical of a commercial application in a 95°F/79°F [35°C/26°C] design area with indoor design of 76°F [24°C] DB and 50% RH and 10% ventilation air, with the unit mounted and centered on the zone it conditions by ducts.

[] Designates Metric Conversions

COOLING PERFORMANCE DATA—RPWL-090/RHGM-090

ENTERING INDOOR AIR @ 80°F [26.7°C] dbE ①											
wbE		71°F [21.7°C]			67°F [19.4°C]			63°F [17.2°C]			
CFM [L/s]		3600 [1699]	3000 [1416]	2400 [1133]	3600 [1699]	3000 [1416]	2400 [1133]	3600 [1699]	3000 [1416]	2400 [1133]	
DR ①		.04	.06	.09	.04	.06	.09	.04	.06	.09	
OUTDOOR DRY BULB TEMPERATURE °F [°C]	75 [23.9]	Total BTUH [kW] Sens BTUH [kW] Power	110.0 [32.2] 69.9 [20.5] 5.7	106.1 [31.1] 60.0 [17.6] 5.6	102.3 [30.0] 51.0 [15.0] 5.5	103.8 [30.4] 85.0 [24.9] 5.7	100.2 [29.4] 74.1 [21.7] 5.6	96.5 [28.3] 63.8 [18.7] 5.5	96.9 [28.4] 92.7 [27.2] 5.6	93.5 [27.4] 81.4 [23.9] 5.5	90.1 [26.4] 70.7 [20.7] 5.4
	80 [26.7]	Total BTUH [kW] Sens BTUH [kW] Power	107.0 [31.4] 68.9 [20.2] 6.0	103.3 [30.3] 59.3 [17.4] 5.9	99.5 [29.2] 50.3 [14.8] 5.8	100.8 [29.5] 84.0 [24.6] 6.0	97.3 [28.5] 73.3 [21.5] 5.9	93.8 [27.5] 63.3 [18.6] 5.8	93.9 [27.5] 91.7 [26.9] 5.9	90.6 [26.6] 80.6 [23.6] 5.8	87.3 [25.6] 70.1 [20.6] 5.7
	85 [29.4]	Total BTUH [kW] Sens BTUH [kW] Power	104.1 [30.5] 67.8 [19.9] 6.3	100.4 [29.4] 58.3 [17.1] 6.2	96.8 [28.4] 49.6 [14.5] 6.1	97.9 [28.7] 83.0 [24.3] 6.3	94.5 [27.7] 72.5 [21.3] 6.1	91.0 [26.7] 62.6 [18.4] 6.0	90.9 [26.6] 90.5 [26.5] 6.2	87.8 [25.7] 79.7 [23.4] 6.1	84.6 [24.8] 69.4 [20.3] 6.0
	90 [32.2]	Total BTUH [kW] Sens BTUH [kW] Power	101.2 [29.7] 66.6 [19.5] 6.6	97.6 [28.6] 57.3 [16.8] 6.5	94.1 [27.6] 48.8 [14.3] 6.4	95.0 [27.8] 81.8 [24.0] 6.6	91.6 [26.8] 71.4 [20.9] 6.4	88.3 [25.9] 61.7 [18.1] 6.3	88.0 [25.8] 88.0 [25.8] 6.5	84.9 [24.9] 78.6 [23.0] 6.4	81.8 [24.0] 68.5 [20.1] 6.3
	95 [35]	Total BTUH [kW] Sens BTUH [kW] Power	98.3 [28.8] 65.3 [19.1] 7.0	94.8 [27.8] 56.2 [16.5] 6.8	91.4 [26.8] 47.9 [14.0] 6.7	92.1 [27.0] 80.4 [23.6] 6.9	88.8 [26.0] 70.2 [20.6] 6.8	85.6 [25.1] 60.7 [17.8] 6.7	85.1 [24.9] 85.1 [25.0] 6.8	82.1 [24.1] 77.5 [22.7] 6.7	79.1 [23.2] 67.5 [19.8] 6.6
	100 [37.8]	Total BTUH [kW] Sens BTUH [kW] Power	95.4 [28.0] 63.7 [18.7] 7.3	92.0 [27.0] 54.9 [16.1] 7.2	88.7 [26.0] 46.8 [13.7] 7.0	89.2 [26.1] 78.8 [23.1] 7.2	86.0 [25.2] 68.9 [20.2] 7.1	82.9 [24.3] 59.7 [17.5] 7.0	82.2 [24.1] 82.2 [24.1] 7.2	79.3 [23.2] 76.2 [22.3] 7.0	76.5 [22.4] 66.5 [19.5] 6.9
	105 [40.6]	Total BTUH [kW] Sens BTUH [kW] Power	92.5 [27.1] 62.0 [18.2] 7.7	89.3 [26.2] 53.5 [15.7] 7.5	86.0 [25.2] 45.5 [13.3] 7.4	86.3 [25.3] 77.1 [22.6] 7.6	83.3 [24.4] 67.5 [19.8] 7.5	80.3 [23.5] 58.5 [17.2] 7.3	79.4 [23.3] 79.4 [23.3] 7.5	76.6 [22.4] 74.8 [21.9] 7.4	73.8 [21.6] 65.3 [19.1] 7.3
	110 [43.3]	Total BTUH [kW] Sens BTUH [kW] Power	89.7 [26.3] 60.2 [17.7] 8.0	86.5 [25.4] 51.9 [15.2] 7.9	83.4 [24.4] 44.2 [13.0] 7.8	83.5 [24.5] 75.3 [22.1] 8.0	80.5 [23.6] 65.9 [19.3] 7.8	77.6 [22.7] 57.1 [16.7] 7.7	76.5 [22.4] 76.5 [22.4] 7.9	73.8 [21.6] 73.2 [21.5] 7.8	71.2 [20.9] 64.0 [18.8] 7.6
	115 [46.1]	Total BTUH [kW] Sens BTUH [kW] Power	86.9 [25.5] 58.4 [17.1] 8.4	83.8 [24.6] 50.3 [14.8] 8.3	80.8 [23.7] 42.9 [12.6] 8.2	80.6 [23.6] 73.4 [21.5] 8.4	77.8 [22.8] 64.3 [18.9] 8.2	75.0 [22.0] 55.8 [16.4] 8.1	73.7 [21.6] 73.7 [21.6] 8.3	71.1 [20.8] 71.1 [20.8] 8.2	68.5 [20.1] 62.5 [18.3] 8.0

DR —Depression ratio
dbE —Entering air dry bulb
wbE—Entering air wet bulb

Total —Total capacity x 1000 BTUH
Sens —Sensible capacity x 1000 BTUH
Power—KW input

NOTES:

① When the entering air dry bulb is other than 80°F [27°C], adjust the sensible capacity from the table by adding [1.10 x CFM x (1 - DR) x (dbE - 80)].

HEATING PERFORMANCE DATA—RPWL-090/RHGM-090

IDB		60°F [15.5°C]			70°F [21.1°C]			80°F [26.7°C]			
CFM [L/s]		3600 [1699]	3000 [1416]	2400 [1133]	3600 [1699]	3000 [1416]	2400 [1133]	3600 [1699]	3000 [1416]	2400 [1133]	
OUTDOOR DRY BULB TEMPERATURE °F [°C]	0 [-17.8]	Total BTUH [kW] Power	41.8 [12.25] 4.5	41.2 [12.07] 4.6	40.6 [11.90] 4.8	36.5 [10.70] 5.0	36.0 [10.55] 5.2	35.5 [10.40] 5.3	31.2 [9.14] 5.6	30.8 [9.03] 5.8	30.3 [8.88] 5.9
	5 [-15]	Total BTUH [kW] Power	47.3 [13.86] 4.6	46.7 [13.69] 4.7	46.0 [13.48] 4.8	42.0 [12.31] 5.1	41.4 [12.13] 5.2	40.9 [11.99] 5.7	36.7 [10.76] 5.7	36.2 [10.61] 5.9	35.7 [10.46] 6.0
	10 [-12.2]	Total BTUH [kW] Power	52.9 [15.50] 4.7	52.1 [15.27] 4.8	51.4 [15.06] 4.9	47.6 [13.95] 5.2	46.9 [13.75] 5.3	46.2 [13.54] 5.5	42.3 [12.40] 5.8	41.7 [12.22] 6.0	41.1 [12.05] 6.1
	15 [-9.4]	Total BTUH [kW] Power	58.4 [17.12] 4.8	57.5 [16.85] 4.9	56.7 [16.62] 5.0	53.1 [15.56] 5.3	52.3 [15.33] 5.4	51.6 [15.12] 5.6	47.8 [14.01] 5.9	47.1 [13.80] 6.0	46.4 [13.60] 6.2
	20 [-6.7]	Total BTUH [kW] Power	63.9 [18.73] 4.9	63.0 [18.46] 5.0	62.1 [18.20] 5.1	58.6 [17.17] 5.4	57.8 [16.94] 5.5	57.0 [16.71] 5.6	53.3 [15.62] 6	52.6 [15.42] 6.1	51.8 [15.18] 6.3
	25 [-3.9]	Total BTUH [kW] Power	69.4 [20.34] 4.9	68.4 [20.05] 5.1	67.5 [19.78] 5.2	64.1 [18.79] 5.5	63.2 [18.52] 5.6	62.3 [18.26] 5.7	58.8 [17.23] 6.1	58.0 [17.00] 6.2	57.2 [16.76] 6.4
	30 [-1.1]	Total BTUH [kW] Power	74.9 [21.95] 5.0	73.9 [21.66] 5.2	72.8 [21.34] 5.3	69.6 [20.40] 5.5	68.7 [20.13] 5.7	67.7 [19.84] 5.8	64.4 [18.87] 6.1	63.4 [18.58] 6.3	62.5 [18.32] 6.5
	35 [1.7]	Total BTUH [kW] Power	80.5 [23.59] 5.1	79.3 [23.24] 5.2	78.2 [22.92] 5.4	75.2 [22.04] 5.6	74.1 [21.72] 5.8	73.0 [21.39] 5.9	69.9 [20.49] 6.2	68.9 [20.19] 6.4	67.9 [19.90] 6.5
	40 [4.4]	Total BTUH [kW] Power	86.0 [25.20] 5.2	84.8 [24.85] 5.3	83.6 [24.50] 5.5	80.7 [23.65] 5.7	79.5 [23.30] 5.8	78.4 [22.98] 6.0	75.4 [22.10] 6.3	74.3 [21.78] 6.5	73.3 [21.48] 6.6
	45 [7.2]	Total BTUH [kW] Power	91.5 [26.82] 5.3	90.2 [26.44] 5.4	88.9 [26.05] 5.5	86.2 [25.26] 5.8	85.0 [24.91] 5.9	83.8 [24.56] 6.1	80.9 [23.71] 6.4	79.8 [23.39] 6.6	78.6 [23.04] 6.7
50 [10]	Total BTUH [kW] Power	97.0 [28.43] 5.4	95.6 [28.02] 5.5	94.3 [27.64] 5.6	91.7 [26.87] 5.9	90.4 [26.49] 6.0	89.1 [26.11] 6.2	86.4 [25.32] 6.5	85.2 [24.97] 6.6	84.0 [24.62] 6.8	

IDB—Indoor air dry bulb

[] Designates Metric Conversions

AIRFLOW CORRECTION FACTORS* RPWL-090 with RHGM-120 @ 3200 CFM [1510 L/s]

ACTUAL—CFM [L/s]	2600 [1227]	2800 [1321]	3000 [1416]	3200 [1510]	3400 [1605]	3600 [1699]	3800 [1793]
TOTAL MBH	.97	.98	.99	1.00	1.01	1.02	1.03
SENSIBLE MBH	.91	.94	.97	1.00	1.03	1.06	1.09
POWER KW	.99	.99	1.00	1.00	1.00	1.01	1.01

*Airflow correction factor table for matched systems example (above) only.

COOLING PERFORMANCE DATA—RPWL-120/RHGM-120

ENTERING INDOOR AIR @ 80°F [26.7°C] dbE ①											
wbE		71°F [21.7°C]			67°F [19.4°C]			63°F [17.2°C]			
CFM [L/s]		4500 [2124]	3750 [1770]	3000 [1416]	4500 [2124]	3750 [1770]	3000 [1416]	4500 [2124]	3750 [1770]	3000 [1416]	
DR ①		.01	.05	.09	.01	.05	.09	.01	.05	.09	
OUTDOOR DRY BULB TEMPERATURE °F [°C]	75 [23.9]	Total BTUH [kW] Sens BTUH [kW] Power	149.2 [43.7] 83.7 [24.5] 7.4	144.0 [42.2] 71.4 [20.9] 7.3	138.7 [40.6] 59.9 [17.6] 7.1	140.2 [41.1] 107.4 [31.5] 7.2	135.3 [39.7] 93.3 [27.4] 7.1	130.4 [38.2] 80.1 [23.5] 7.0	133.9 [39.2] 123.7 [36.3] 7.1	129.2 [37.9] 108.4 [31.8] 7.0	124.5 [36.5] 94.0 [27.6] 6.8
	80 [26.7]	Total BTUH [kW] Sens BTUH [kW] Power	145.7 [42.7] 84.4 [24.7] 7.8	140.6 [41.2] 72.1 [21.1] 7.6	135.5 [39.7] 60.7 [17.8] 7.5	136.7 [40.1] 108.1 [31.7] 7.6	131.9 [38.7] 94.1 [27.6] 7.5	127.1 [37.2] 81.0 [23.7] 7.4	130.5 [38.2] 124.5 [36.5] 7.5	125.9 [36.9] 109.3 [32.0] 7.3	121.3 [35.5] 94.9 [27.8] 7.2
	85 [29.4]	Total BTUH [kW] Sens BTUH [kW] Power	142.2 [41.7] 84.5 [24.8] 8.2	137.2 [40.2] 72.3 [21.2] 8.0	132.2 [38.7] 61.0 [17.9] 7.9	133.2 [39.0] 108.1 [31.7] 8.0	128.5 [37.7] 94.2 [27.6] 7.9	123.9 [36.3] 81.2 [23.8] 7.8	126.9 [37.2] 124.4 [36.5] 7.9	122.5 [35.9] 109.4 [32.1] 7.7	118.0 [34.6] 95.1 [27.9] 7.6
	90 [32.2]	Total BTUH [kW] Sens BTUH [kW] Power	138.6 [40.6] 83.7 [24.5] 8.6	133.8 [39.2] 71.8 [21.1] 8.5	128.9 [37.8] 60.7 [17.8] 8.3	129.6 [38.0] 107.5 [31.5] 8.5	125.1 [36.7] 93.8 [27.5] 8.3	120.5 [35.3] 80.9 [23.7] 8.2	123.4 [36.2] 123.4 [36.2] 8.3	119.0 [34.9] 108.9 [31.9] 8.2	114.7 [33.6] 94.8 [27.8] 8.0
	95 [35]	Total BTUH [kW] Sens BTUH [kW] Power	135.0 [39.6] 82.4 [24.2] 9.1	130.3 [38.2] 70.7 [20.7] 8.9	125.6 [36.8] 59.8 [17.5] 8.7	126.0 [36.9] 106.2 [31.1] 8.9	121.6 [35.6] 92.7 [27.2] 8.8	117.2 [34.3] 80.1 [23.5] 8.6	119.8 [35.1] 119.8 [35.1] 8.8	115.6 [33.9] 107.9 [31.6] 8.6	111.4 [32.6] 94.0 [27.6] 8.5
	100 [37.8]	Total BTUH [kW] Sens BTUH [kW] Power	131.4 [38.5] 80.5 [23.6] 9.5	126.8 [37.2] 69.0 [20.2] 9.4	122.2 [35.8] 58.4 [17.1] 9.2	122.4 [35.9] 104.2 [30.5] 9.4	118.1 [34.6] 91.0 [26.7] 9.2	113.8 [33.4] 78.6 [23.0] 9.1	116.1 [34.0] 116.1 [34.0] 9.2	112.0 [32.8] 106.1 [31.1] 9.1	108.0 [31.7] 92.6 [27.1] 8.9
	105 [40.6]	Total BTUH [kW] Sens BTUH [kW] Power	127.7 [37.4] 77.8 [22.8] 10.0	123.2 [36.1] 66.7 [19.6] 9.9	118.7 [34.8] 56.4 [16.5] 9.7	118.7 [34.8] 101.5 [29.8] 9.9	114.5 [33.6] 88.6 [26.0] 9.7	110.4 [32.4] 76.6 [22.5] 9.5	112.4 [32.9] 112.4 [33.0] 9.7	108.5 [31.8] 103.9 [30.5] 9.6	104.5 [30.6] 90.6 [26.6] 9.4
	110 [43.3]	Total BTUH [kW] Sens BTUH [kW] Power	124.0 [36.3] 74.5 [21.8] 10.6	119.6 [35.1] 63.7 [18.7] 10.4	115.3 [33.8] 53.9 [15.8] 10.2	115.0 [33.7] 98.2 [28.8] 10.4	110.9 [32.5] 85.7 [25.1] 10.2	106.9 [31.3] 74.1 [21.7] 10.1	108.7 [31.9] 108.7 [31.9] 10.3	104.9 [30.7] 100.9 [29.6] 10.1	101.1 [29.6] 88.0 [25.8] 9.9
	115 [46.1]	Total BTUH [kW] Sens BTUH [kW] Power	120.2 [35.2] 70.4 [20.6] 11.1	116.0 [34.0] 60.2 [17.7] 10.9	111.7 [32.7] 50.7 [14.9] 10.7	111.2 [32.6] 94.1 [27.6] 11.0	107.3 [31.4] 82.2 [24.1] 10.8	103.4 [30.3] 71.0 [20.8] 10.6	104.9 [30.7] 104.9 [30.8] 10.8	101.2 [29.7] 97.3 [28.5] 10.6	97.5 [28.6] 84.9 [24.9] 10.4

DR —Depression ratio
dbE—Entering air dry bulb
wbE—Entering air wet bulb

Total —Total capacity x 1000 BTUH
Sens —Sensible capacity x 1000 BTUH
Power—kW input

NOTES:
① When the entering air dry bulb is other than 80°F [27°C], adjust the sensible capacity from the table by adding $[1.10 \times \text{CFM} \times (1 - \text{DR}) \times (\text{dbE} - 80)]$.

HEATING PERFORMANCE DATA—RPWL-120/RHGM-120

IDB		60°F [15.5°C]			70°F [21.1°C]			80°F [26.7°C]			
CFM [L/s]		4500 [2124]	3750 [1770]	3000 [1416]	4500 [2124]	3750 [1770]	3000 [1416]	4500 [2124]	3750 [1770]	3000 [1416]	
OUTDOOR DRY BULB TEMPERATURE °F [°C]	0 [-17.8]	Total BTUH [kW] Power	51.0 [14.95] 6.6	50.3 [14.74] 6.7	49.5 [14.51] 6.9	45.1 [13.22] 7.4	44.4 [13.01] 7.6	43.8 [12.84] 7.8	39.2 [11.49] 8.2	38.6 [11.31] 8.4	38.1 [11.17] 8.7
	5 [-15]	Total BTUH [kW] Power	58.5 [17.14] 6.7	57.7 [16.91] 6.9	56.9 [16.68] 7.1	52.6 [15.42] 7.5	51.9 [15.21] 7.7	51.1 [14.98] 7.9	46.7 [13.69] 8.4	46.1 [13.51] 8.6	45.4 [13.31] 8.8
	10 [-12.2]	Total BTUH [kW] Power	66.1 [19.37] 6.9	65.1 [19.08] 7.0	64.2 [18.82] 7.2	60.2 [17.64] 7.7	59.3 [17.38] 7.9	58.5 [17.14] 8.1	54.3 [15.91] 8.5	53.5 [15.68] 8.7	52.7 [15.44] 9.0
	15 [-9.4]	Total BTUH [kW] Power	73.6 [21.57] 7.0	72.6 [21.28] 7.2	71.5 [20.95] 7.4	67.7 [19.84] 7.8	66.8 [19.58] 8.0	65.8 [19.28] 8.2	61.8 [18.11] 8.7	60.9 [17.85] 8.9	60.1 [17.61] 9.1
	20 [-6.7]	Total BTUH [kW] Power	81.2 [23.80] 7.2	80.0 [23.45] 7.3	78.9 [23.12] 7.5	75.3 [22.07] 8.0	74.2 [21.75] 8.2	73.1 [21.42] 8.4	69.4 [20.34] 8.8	68.4 [20.05] 9.1	67.4 [19.75] 9.3
	25 [-3.9]	Total BTUH [kW] Power	88.7 [26.00] 7.3	87.5 [25.64] 7.5	86.2 [25.26] 7.7	82.8 [24.27] 8.1	81.6 [23.91] 8.3	80.5 [23.59] 8.5	76.9 [22.54] 9.0	75.8 [22.21] 9.2	74.7 [21.89] 9.4
	30 [-1.1]	Total BTUH [kW] Power	96.3 [28.22] 7.5	94.9 [27.81] 7.6	93.6 [27.43] 7.8	90.4 [26.49] 8.3	89.1 [26.11] 8.5	87.8 [25.73] 8.7	84.5 [24.76] 9.1	83.3 [24.41] 9.4	82.1 [24.06] 9.6
	35 [1.7]	Total BTUH [kW] Power	103.8 [30.42] 7.6	102.3 [29.98] 7.8	100.9 [29.57] 8.0	97.9 [28.69] 8.4	96.5 [28.28] 8.6	95.1 [27.87] 8.9	92.0 [26.96] 9.3	90.7 [26.58] 9.5	89.4 [26.20] 9.7
	40 [4.4]	Total BTUH [kW] Power	111.4 [32.65] 7.8	109.8 [32.18] 8.0	108.2 [31.71] 8.2	105.5 [30.92] 8.6	104.0 [30.48] 8.8	102.5 [30.04] 9.0	99.5 [29.16] 9.4	98.1 [28.75] 9.7	96.7 [28.34] 9.9
	45 [7.2]	Total BTUH [kW] Power	118.9 [34.85] 7.9	117.2 [34.35] 8.1	115.6 [33.88] 8.3	113.0 [33.12] 8.7	111.4 [32.65] 8.9	109.8 [32.18] 9.2	107.1 [31.39] 9.6	105.6 [30.95] 9.8	104.1 [30.51] 10.1
50 [10]	Total BTUH [kW] Power	126.5 [37.07] 8.0	124.7 [36.55] 8.3	122.9 [36.02] 8.5	120.5 [35.32] 8.9	118.9 [34.85] 9.1	117.2 [34.35] 9.3	114.6 [33.59] 9.7	113.0 [33.12] 10.0	111.4 [32.65] 10.2	

IDB—Indoor air dry bulb

[] Designates Metric Conversions

AIRFLOW CORRECTION FACTORS* RPWL-120 with RHGM-120 @ 3700 CFM [1746 L/s]

ACTUAL—CFM [L/s]	3100 [1463]	3300 [1557]	3500 [1588]	3700 [1746]	3900 [1841]	4100 [1935]	4300 [2029]	4400 [2077]
TOTAL MBH	.97	.98	.99	1.00	1.01	1.02	1.03	1.04
SENSIBLE MBH	.92	.95	.97	1.00	1.03	1.05	1.08	1.09
POWER KW	.98	.99	.99	1.00	1.01	1.01	1.02	1.02

*Airflow correction factor table for matched systems example (above) only.

TYPICAL REFRIGERANT PIPING RECOMMENDATIONS

General Notes:

1. Vertical risers not to exceed 60 feet [18.29 m].
2. Locate the remote heat pump unit and indoor air handler as close together as possible to minimize piping runs.
3. Remote heat pump units are shipped with a nitrogen holding charge. Evacuate remote heat pump unit before charging with refrigerant.
4. Runs between remote heat pump and indoor air handler are not to exceed 90' [27.43 m] linear length.

EQUIVALENT LENGTH (FT.) [m] OF STRAIGHT TYPE "L" TUBING FOR NON-FERROUS VALVES AND FITTINGS (BRAZED)				
TUBE SIZE INCHES [mm] O.D.	ANGLE VALVE	SHORT RADIUS ELL	LONG RADIUS ELL	TEE LINE FLOW
1/2 [12.7]	24 [7.32]	4.7 [1.43]	3.2 [0.98]	1.7 [0.52]
5/8 [15.88]	25 [7.62]	5.7 [1.74]	3.9 [1.19]	2.3 [0.70]
3/4 [19.05]	25 [7.62]	6.5 [1.98]	4.5 [1.37]	2.9 [0.88]
7/8 [22.23]	28 [8.53]	7.8 [2.38]	5.3 [1.62]	3.7 [1.13]
1 1/8 [28.58]	29 [8.84]	2.7 [0.82]	1.9 [0.58]	5.2 [1.59]
1 3/8 [34.93]	33 [10.06]	3.2 [0.98]	2.2 [0.67]	6.9 [2.10]

RECOMMENDED VAPOR AND LIQUID LINE SIZES FOR VARIOUS LENGTHS OF RUN				
LINEAR LENGTH (FT.) [m]	LIQUID LINE O.D. SIZES (IN.) [mm]		VAPOR LINE O.D. SIZES (IN.) [mm]	
	090	120	090	120
0-40 [0-12.19]	1/2 [12.7]	5/8 [15.88]	1 1/8 [28.58]	1 3/8 [34.93]
41-90 [12.5-27.43]	1/2 [12.7]	5/8 [15.88]	1 3/8 [34.93]*	1 3/8 [34.93]*

*NOTE: With the outdoor unit located below the indoor air handler, all vertical vapor lines must not exceed 1 1/8" [28.58 mm] O.D.

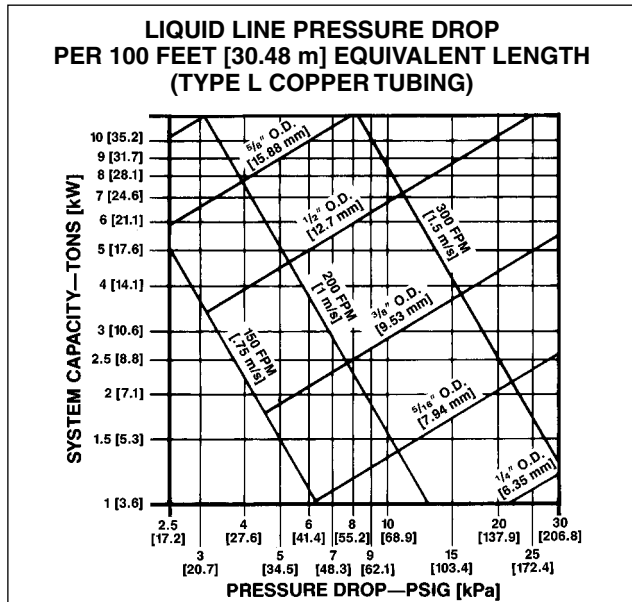

NOTES:

- 1) The pressure drop due to vertical lift (.5 PSIG per foot of lift) [22.62 kPa per meter] **must** be added to the pressure drop derived from this curve.
- 2) Size liquid line for **no more** than 10°F [-12.2°C] loss (approximately 50 PSIG [344.8 kPa] total pressure drop).
- 3) **Do not oversize liquid line.** Oversized liquid lines add significantly to the amount of refrigerant required to charge the system.

WARNING

Do not use oxygen to purge lines or pressure system for leak test. Oxygen reacts violently with oil, which can cause an explosion resulting in severe personal injury or death.

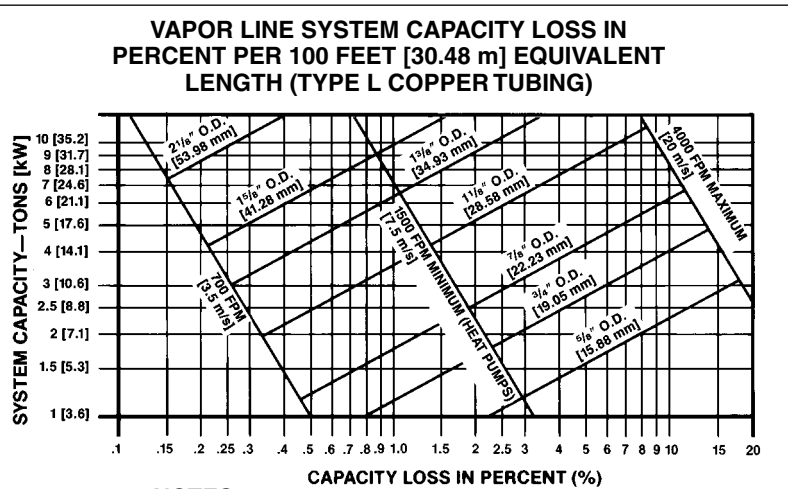

NOTES:

- 1) The minimum velocity line (1500 FPM) [7.5 m/s] is recommended.
- 2) With the outdoor unit located below the indoor air handler, all vertical vapor lines must not exceed 1 1/8" [28.58 mm] O.D.
- 3) For suction pressure drop (PSIG) [6.9 kPa], multiply percent (%) loss by 1.18.
- 4) Size vapor lines for no more than a 5 PSIG [34.5 kPa] pressure drop (2.54% capacity loss) which corresponds to approximately 2°F [-16.7°C] loss.
- 5) All vertical vapor lines, 3 feet [.91 m] or more in length, must have a short radius oil trap at the bottom of the riser.
- 6) All vertical vapor lines, 30 feet [9.14 m] or more in length, must have short radius oil traps every 15 to 20 feet [4.57 to 6.10 m] of run.

COIL ABOVE HEAT PUMP UNIT

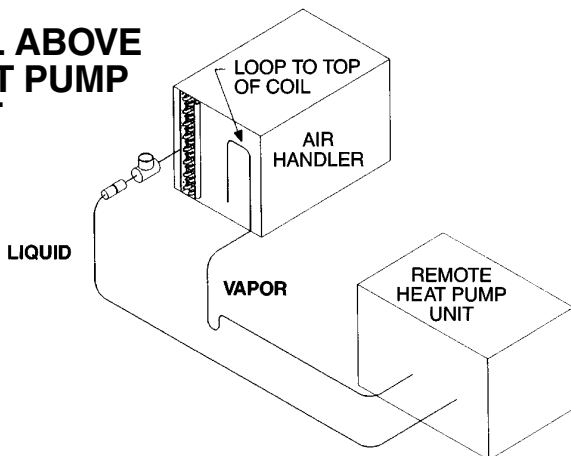

COIL BELOW HEAT PUMP UNIT

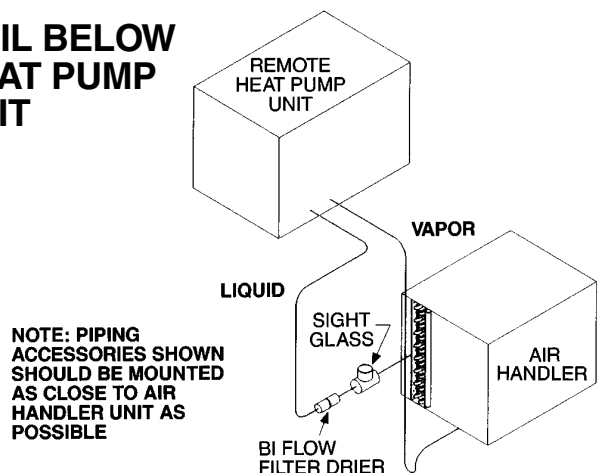

NOTE: PIPING ACCESSORIES SHOWN SHOULD BE MOUNTED AS CLOSE TO AIR HANDLER UNIT AS POSSIBLE

TYPICAL REFRIGERANT PIPING RECOMMENDATIONS (con't.)

REQUIRED OZS. R-410A
CHARGE PER FT. [m] OF TUBING

TUBE SIZE O.D. (IN.) [mm]	LIQUID (OZ.) [g]	VAPOR (OZ.) [g]
1/2 [12.7]	1.06 [30.0]	.04 [1.13]
5/8 [15.88]	1.65 [46.7]	.07 [1.98]
3/4 [19.05]	2.46 [69.7]	.10 [2.83]
7/8 [22.23]	3.28 [92.9]	.13 [3.68]
1 1/8 [28.58]		.22 [6.23]
1 3/8 [34.93]		.34 [9.63]
1 5/8 [41.28]		.48 [13.60]
2 1/8 [53.98]		.84 [23.81]

Quantities based on 110°F liquid and 45°F vapor.

GENERAL INSTALLATION 7.5 TON [26.38 kW] & 10 TON [35 kW]

The condensing unit should be installed outdoors. It should be located as near as possible to the evaporator section to keep connecting refrigerant tubing lengths to a minimum. The unit must be installed to allow a free air flow to the condenser coils.

If several units are installed adjacent to each other, care must be taken to avoid recirculation of air from one condenser to another. In all installations, adequate space must be provided for installation and servicing.

CLEARANCES

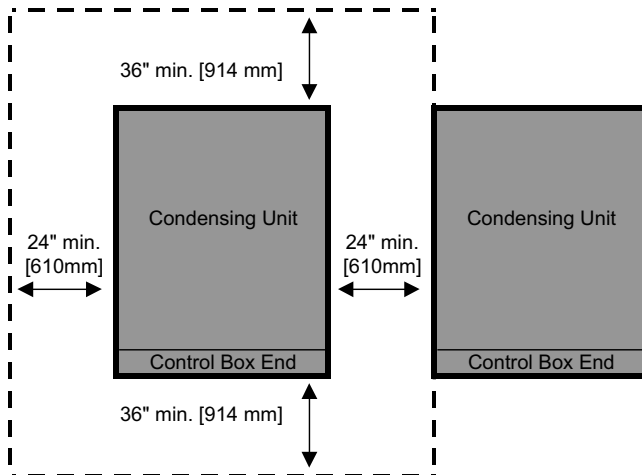

The unit must not be connected to any duct work. Do not locate unit under a roof drip; if necessary, install gutters, etc., to prevent water run-off from hitting the unit. To prevent air recirculation, it is recommended that the unit not be installed under an overhang, but if necessary allow a minimum of 60 inches [1524 mm] above the unit for air discharge.

ROOFTOP INSTALLATION

If rooftop installation is required, make certain that the building construction is adequate for the weight of the unit. (Refer to physical data chart.) Before placing the unit on the roof, make certain that the nylon rigging slings are of sufficient length to maintain equilibrium of the unit when lifting. Under no circumstances should the unit be lifted by only one corner for rooftop installation.

[] Designates Metric Conversions

RIGGING

RPWL 090 & 120 MODELS

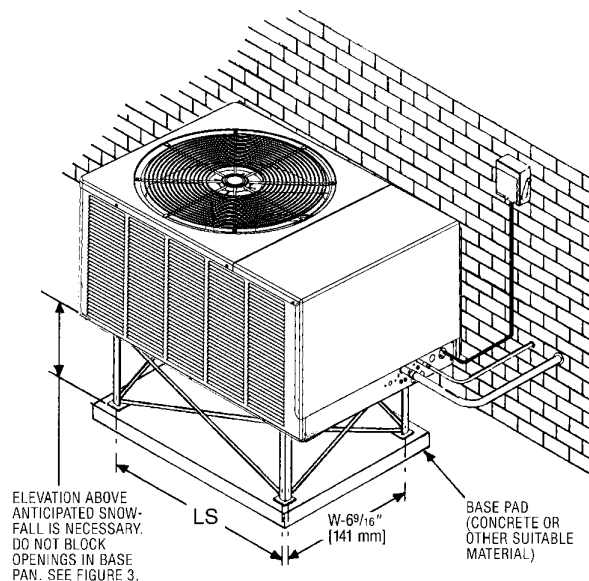
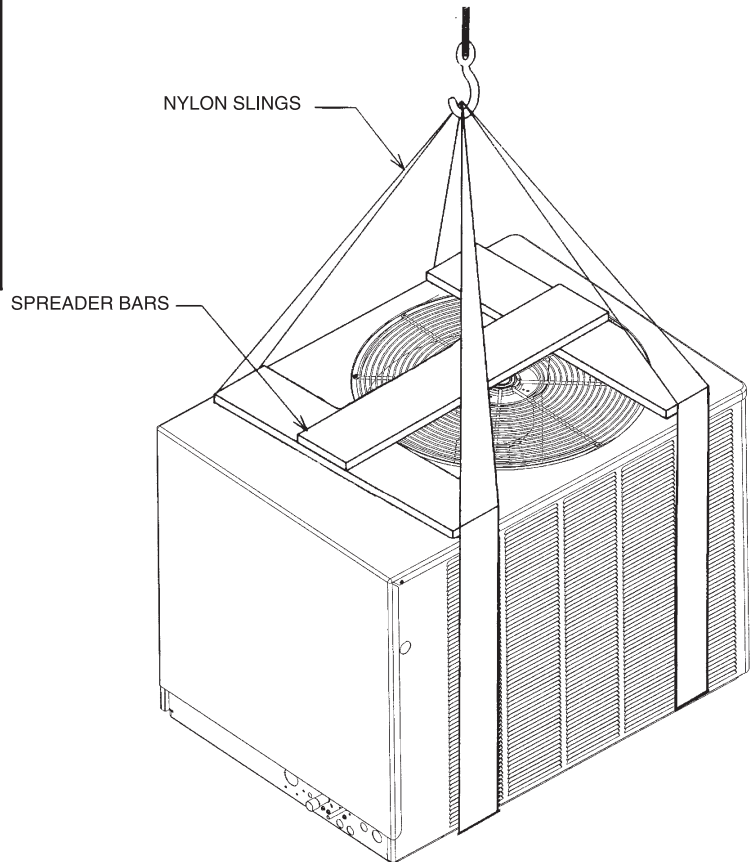

GENERAL INSTALLATION

The Remote Heat Pump unit must be installed outdoors. It should be located as near as possible to the indoor section to keep connecting refrigerant tubing lengths to a minimum. The unit must be installed to allow a free air flow to the outdoor coils.

If several units are installed adjacent to each other, care must be taken to avoid recirculation of air from one remote heat pump to another. In all installations, adequate space must be provided for installation and servicing.

The outdoor unit must not be connected to any duct work. Do not locate unit under a roof drip; if necessary, install gutters, etc., to prevent water run-off from hitting the unit. To prevent air recirculation, it is recommended that the unit not be installed under an overhang, but if necessary **allow a minimum of 60 inches [1524 mm] above the unit for air discharge.**

[] Designates Metric Conversions

SLAB INSTALLATION

Remote Heat Pump units should be set on a solid level foundation. When installed at ground level, the unit should be placed on a 6 inch [152.4 mm] cement slab. If the pad is formed at the installation site, do not pour the pad tight against the structure, otherwise vibration will be transmitted from the unit through the pad.

ROOFTOP INSTALLATION

If rooftop installation is required, make certain that the building construction is adequate for the weight of the unit. (Refer to physical data chart.) Before placing the unit on the roof, make certain that the nylon rigging slings are of sufficient length to maintain equilibrium of the unit when lifting. Under no circumstances should the unit be lifted by only one corner for rooftop installation.

RIGGING

120 MODELS

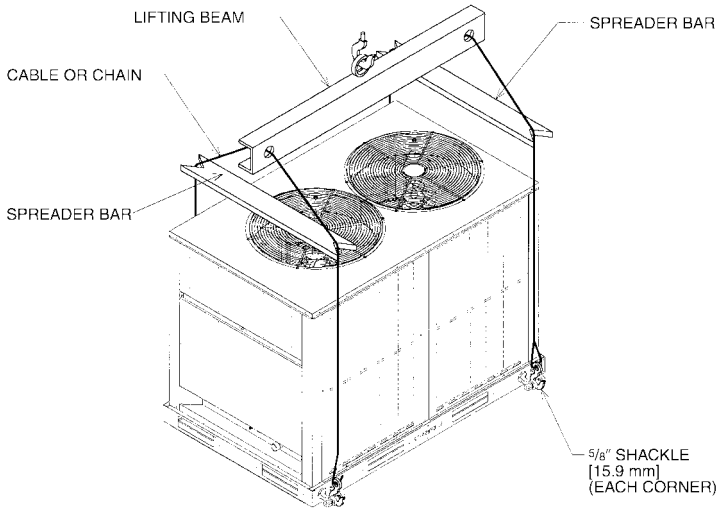

TYPICAL FIELD WIRING CONNECTIONS

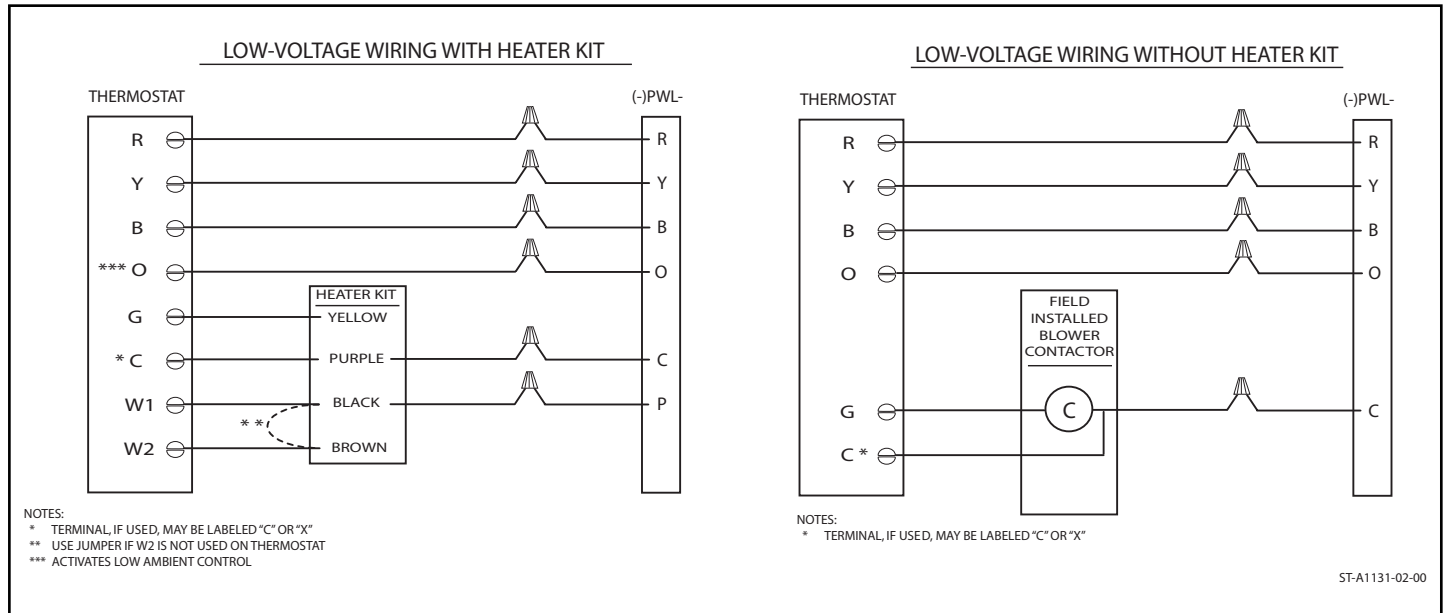

THERMOSTATS



100-Series *
Non-Programmable



200-Series *
Programmable



300-Series *
Deluxe Programmable



500-Series *
Communicating/Programmable

400-Series *
Special Applications/Programmable

Brand	Unique Model Number Prefix	Descriptor (3 Characters)	Series (3 Characters)	System (2 Characters)	Type (2 Characters)
RHC	-	TST	101	GE	MS
RHC=Rheem		TST=Thermostat	100=Non-Programmable 200=Programmable 300=Deluxe Programmable 400=Special Applications/Programmable 500=Communicating/Programmable	GE=Gas/Oil/Electric HP=Heat Pump MD=Modulating Furnace DF=Dual Fuel UN=Universal AC/HP/GE CM=Communicating	SS=Single-Stage MS=Multi-Stage

* Photos are representative. Actual models may vary.

For detailed thermostat match-up information, see specification sheet form number T11-001.

TYPICAL WIRING SCHEMATICS

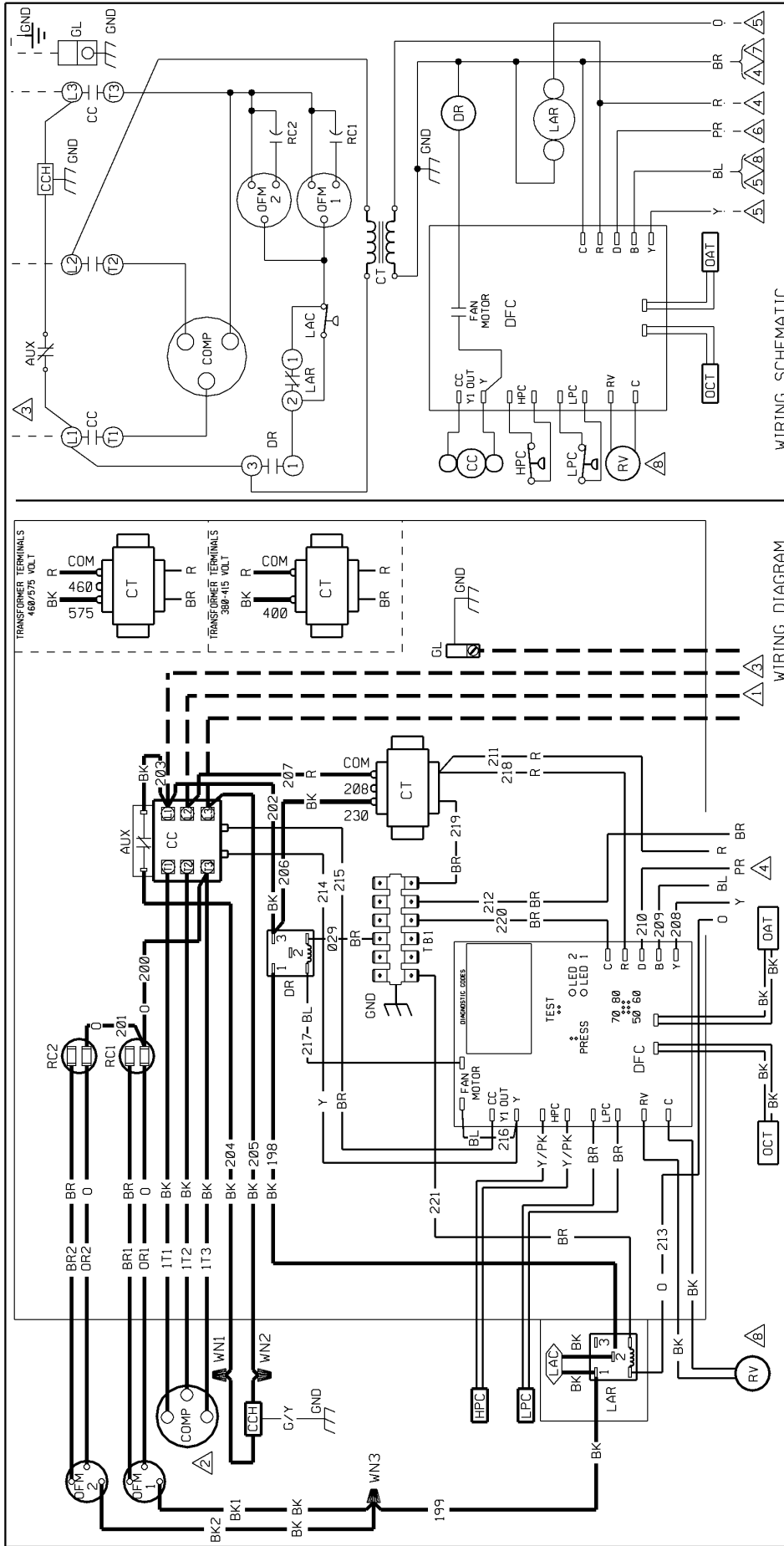

WIRING SCHEMATIC

WIRING DIAGRAM

WIRE COLOR CODE	
BK	BLACK
BR	BROWN
BL	BLUE
G	GREEN
GY	GRAY
O	ORANGE
PR	PURPLE
R	RED
W	WHITE
Y	YELLOW

ELECTRICAL WIRING DIAGRAM	
208-230V	REMOTE HEAT PUMP
460V / 575V	THREE PHASE
380-415V	DEMAND DEFROST CONTROL

WIRING INFORMATION	
LINE VOLTAGE	-FACTORY STANDARD
-FACTORY OPTION	-FIELD INSTALLED
LOW VOLTAGE	-FACTORY STANDARD
-FACTORY OPTION	-FIELD INSTALLED
REPLACEMENT WIRE	-MUST BE THE SAME SIZE AND TYPE OF INSULATION AS ORIGINAL (105 C.MIN.)
WARNING	-CABINET MUST BE PERMANENTLY GROUNDED AND CONFORM TO I.E.C., N.E.C., C.E.C., NATIONAL WIRING REGULATIONS, AND LOCAL CODES AS APPLICABLE.

NOTES:	
1.	CONNECTORS SUITABLE FOR USE WITH COPPER CONDUCTORS ONLY.
2.	COMPRESSOR MOTOR THERMALLY PROTECTED AND ALL 3 PHASE ARE PROTECTED UNDER PRIMARY SINGLE PHASE CONDITIONS.
3.	CONNECT FIELD WIRING IN GROUNDED RAIN-TIGHT CONDUIT TO 60 HERTZ FUSE DISCONNECT, VOLTAGE AND PHASE PER WIRING PLATE.
4.	LOW VOLTAGE CIRCUIT TO BE N.E.C. CLASS 2 WITH A CLASS 2 TRANSFORMER 24 VOLT, 60 HERTZ.
5.	TO THERMOSTAT SUB-BASE REFER TO SYSTEM SCHEMATICS OR SCHEMATICS ON INDOOR SECTION FOR LOW VOLTAGE CONTROL WIRING.
6.	THIS WIRE IS USED TO TURN ON STRIP HEAT DURING DEFROST. OMIT CONNECTION FOR MOST ECONOMICAL OPERATION.
7.	TO HEAT PUMP MONITOR 2.5 VA. MAX. WHEN USED.
8.	THIS COMPONENT IS ENERGIZED IN HEATING MODE.

COMPONENT CODE	
AUX	AUXILIARY SWITCH
CCH	CRANKCASE HEATER
COMP	COMPRESSOR
CT	CONTROL TRANSFORMER
DFC	DEFROST RELAY
DS	DEFROST COIL
GLD	GROUND LUG
HPC	HIGH PRESS. CUT-OUT CONTROL
LAC	LOW AMBIENT COOLING CONTROL
LAR	LOW AMBIENT RELAY
LPC	LOW PRESSURE CUT OUT CONTROL
OAT	OUTDOOR AMBIENT TEMP
OCT	OUTDOOR COIL TEMP
OFM	OUTDOOR FAN MOTOR
PC	PLUM CAPACITOR
RV	REVERSING VALVE
W	WIRE NUT

DWG. NO.	
90-42676-03	REV 02

TYPICAL WIRING SCHEMATICS

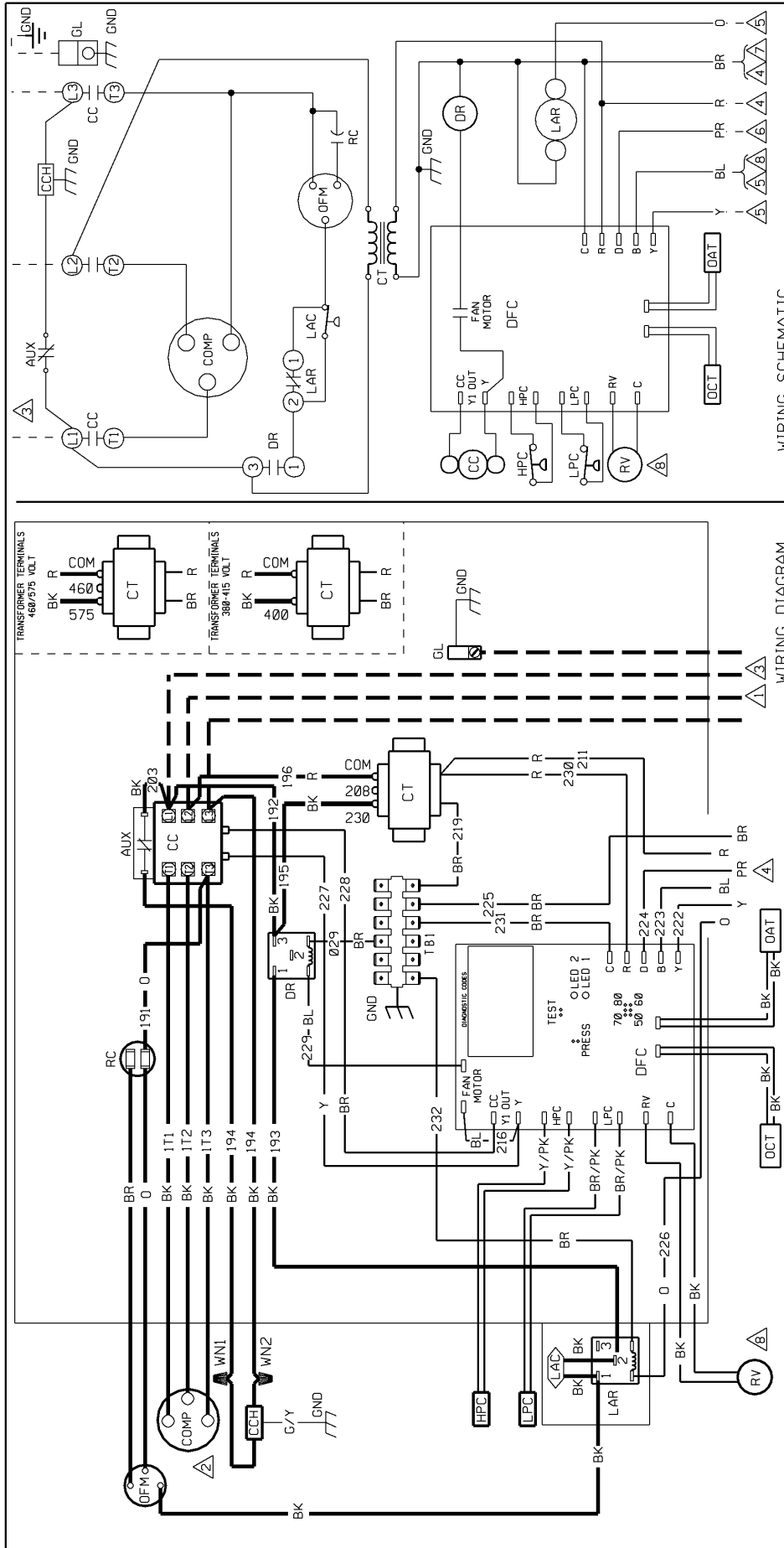

WIRING SCHEMATIC

WIRING DIAGRAM

COMPONENT CODE	
AUX	AUXILIARY SWITCH
CC	COMPRESSOR CONTACTOR
CCH	COMPRESSOR CRANKCASE HEATER
COMP	COMPRESSOR CONTROL
DFC	DEFROST CONTROL
DR	DEFROST RELAY
GS	GROUND LUG
GND	GROUND
HPC	HIGH PRESS. CUT-OUT CONTROL
LAC	LOW AMBIENT COOLING CONTROL
LAR	LOW AMBIENT RELAY
LPC	LOW PRESSURE CUT OUT CONTROL
OAT	OUTDOOR AMBIENT TEMP
OFM	OPTIONAL FAN MOTOR
OPT	OPTIONAL
RC	RUN CAPACITOR
RV	REVERSING VALVE
W	WIRE NUT

WIRING INFORMATION	
—	LINE VOLTAGE
—	-FACTORY STANDARD
—	-FACTORY OPTION
—	-FIELD INSTALLED
—	LOW VOLTAGE
—	-FACTORY STANDARD
—	-FACTORY OPTION
—	-FIELD INSTALLED
—	REPLACEMENT WIRE
—	-MUST BE THE SAME SIZE AND TYPE OF INSULATION AS ORIGINAL (105 C.M.I.N.)
—	-CABINET MUST BE PERMANENTLY GROUNDED AND CONFORM TO I.E.C., N.E.C., C.E.C., NATIONAL WIRING REGULATIONS, AND LOCAL CODES AS APPLICABLE.

NOTES:	
1.	CONNECTORS SUITABLE FOR USE WITH COPPER CONDUCTORS ONLY.
2.	COMPRESSOR MOTOR THERMALLY PROTECTED AND ALL 3 PHASE ARE PROTECTED UNDER PRIMARY SINGLE PHASE CONDITIONS.
3.	CONNECT FIELD WIRING IN GROUNDED RAINTIGHT CONDUIT TO 60 HERTZ FUSE DISCONNECT, VOLTAGE AND PHASE PER RATING PLATE.
4.	LOW VOLTAGE CIRCUIT TO BE N.E.C. CLASS 2 WITH A CLASS 2 TRANSFORMER 24 VOLT, 60 HERTZ.
5.	TO THERMOSTAT SUB-BASE, REFER TO SYSTEM SCHEMATICS OR SCHEMATICS ON INDOOR SECTION FOR LOW VOLTAGE CONTROL WIRING.
6.	THIS WIRE IS USED TO TURN ON STRIP HEAT DURING DEFROST. OMIT CONNECTION FOR MOST ECONOMICAL OPERATION.
7.	TO HEAT PUMP MONITOR 2.5 VA. MAX. WHEN USED.
8.	THIS COMPONENT IS ENERGIZED IN HEATING MODE.

WIRE COLOR CODE	
BK	BLACK
BR	BROWN
BL	BLUE
G	GREEN
GY	GRAY
O	ORANGE
PR	PURPLE
R	RED
W	WHITE
Y	YELLOW

ELECTRICAL WIRING DIAGRAM	
208-230V	REMOTE HEAT PUMP
460V / 575V	THREE PHASE
380-415V	DEMAND DEFROST CONTROL
DR. BY	APP. BY
KDF	KDF
DWG. NO.	DWG. NO.
90-42676-02	90-42676-02
REV	REV
03	03

SEQUENCE OF OPERATION

COOLING MODE

1. With thermostat in the cool mode, fan auto and the room temperature higher than the thermostat setting:
 - a. Indoor blower contactor (BC) is energized through thermostat contact (G) (See Indoor Air Handler).
 - b. Compressor contactor (CC) is energized through thermostat contact (Y) and safety controls.
 - c. Room thermostat locks out the defrost relay (DR), defrost control (DFC) and reversing valve (RV).
 - d. The system will continue in the cooling operation as long as all safety controls are closed until the thermostat is satisfied.
 1. The reversing valve remains in the cooling mode when the thermostat is satisfied.

HEATING MODE

1. With the thermostat in the heat mode, fan auto and the room temperature lower than the thermostat setting.
 - a. Indoor blower contactor (BC) is energized through thermostat contact (G) (See Indoor Air Handler).
 - b. Compressor contactor (CC) is energized through thermostat contact (Y) and safety controls.
 - c. Defrost control (DFC) energized.

1. Reversing valve (RV) and defrost control (DFC) are energized through room thermostat contact (B).
2. The defrost control (DFC) will energize the defrost relay (DR) on a demand basis as required.
- d. Should the heat requirement be more than the heat pump can supply, a portion of the electric heat accessory (if supplied) is energized through room thermostat contact (W2). (See electric heat kit accessory section.)
- e. The system will continue the heating operation as long as all safety controls are closed until the room thermostat is satisfied. The reversing valve remains in the heating mode when the thermostat is satisfied.
- f. The unit will function in a defrost mode, reversing the compressor cycle to cooling and energizing the electric heat kit (if supplied), as required through the defrost relay (DR).
- g. If the refrigerant system becomes inoperable during a need for heating, the room thermostat may be set to "emergency heat" which will energize the remaining portion of the electric heat kit (if supplied).

GUIDE SPECIFICATIONS

GENERAL—Units shall be assembled on heavy gauge steel full perimeter forkable baserails with lifting holes (10 ton only). Unit shall include a hermetic scroll compressor(s), plate fin condenser coil, fans and motors, controls and holding charge of nitrogen. Operating Range shall be between 115°F and 0°F in cooling as standard from factory. Units shall be UL 1995 listed and rated in accordance with AHRI Standard 340.

CASING—Unit shall be constructed of 18 gauge zinc coated heavy gauge, galvanized steel. Units shall have stamped louver panels offering 100% protection of condenser coil guards. Exterior surfaces shall be cleaned, phosphatized and finished with a weather-resistant baked enamel finish. Units surface shall be tested 1000 hours in salt spray test. Units shall have removable end panels which allow access to all major components and controls.

REFRIGERATION SYSTEM—Single Compressor—Units shall have a single refrigeration circuit. Each refrigeration circuit has an integral subcooling circuit. A refrigeration filter drier, expansion valve and check valves shall be provided as standard. The units shall have a liquid line and suction gas line service valve with gauge port. Units shall have one direct drive hermetic scroll compressor with centrifugal oil pump providing positive lubrication to moving parts. Motor shall be suction gas-cooled and shall have a voltage utilization range of plus or minus 10 percent of nameplate voltage. Crankcase heater, internal temperature and current-sensitive motor overloads shall be included for maximum protection. Scroll type compressor shall provide inherently low vibration and noise by having no suction and discharge valves. External high and low pressure cutout devices shall be provided.

CONDENSER COIL—Coils shall be internally finned or smooth bore 3/8" copper tubes mechanically bonded to configured aluminum plate fin as standard. Coil shall be factory pressure and leak tested to 450 psig air pressure.

CONDENSER FAN AND MOTOR(S)—Direct-drive, statically and dynamically balanced propeller fan(s) with aluminum blades and electro²-coated steel hubs shall be used in draw-through vertical discharge position. Permanently lubricated totally enclosed construction type motors shall be provided and shall have built in current and thermal overload protection. Motor(s) shall have either ball or sleeve bearing type.

CONTROLS—Heat pump units shall be completely factory wired with necessary controls and contactor pressure lugs or terminal block for power wiring. Control wiring shall be 24-volt control circuit which includes fusing and control transformer. Units shall provide external location for mounting a fused disconnect device.

DEFROST CONTROLS—Unit shall be equipped with Demand Defrost Control to defrost outdoor coil.

LOW AMBIENT OPERATION—Standard units shall start and operate to 0° F when matched with Rheem air handlers and coils. Standard head pressure control permits operation to 0° F.

ANTI-SHORT-CYCLE TIMER—Shall prevent rapid on-off compressor cycling in light load conditions by not allowing compressor to operate for 5-7 minutes upon shutdown. Shall consist of a solid state timing device, 24-volt, 60 cycle with either 5 or 7 minute fixed-off timing period.

GENERAL TERMS OF LIMITED WARRANTY*

Rheem will furnish a replacement for any part of this product which fails in normal use and services within the applicable periods stated here, in accordance with the terms of the limited warranty.

Compressor.....Five (5) Years
Any Other Part.....One (1) Year

*For Complete Details of the Limited Warranty, Including Applicable Terms and Conditions, See Your Local Installer or Contact the Manufacturer for a Copy.

Before proceeding with installation, refer to installation instructions packaged with each model, as well as complying with all Federal, State, Provincial, and Local codes, regulations, and practices.

**Rheem Heating,
Cooling and
Water Heating**

P.O. Box 17010, Fort Smith, AR 72917



"In keeping with its policy of continuous progress and product improvement, Rheem reserves the right to make changes without notice."