

INSTALLATION INSTRUCTIONS

Heat Pump Outdoor Units Equipped with the *Comfort Control System™*

(-)PQL-JEZ MODEL SERIES - 15 SEER



Featuring Earth Friendly
R-410A Refrigerant **R-410A**
earth friendly refrigerant



RECOGNIZE THIS SYMBOL AS AN INDICATION OF IMPORTANT SAFETY INFORMATION!

▲ WARNING

THESE INSTRUCTIONS ARE INTENDED AS AN AID TO QUALIFIED, LICENSED SERVICE PERSONNEL FOR PROPER INSTALLATION, ADJUSTMENT AND OPERATION OF THIS UNIT. READ THESE INSTRUCTIONS THOROUGHLY BEFORE ATTEMPTING INSTALLATION OR OPERATION. FAILURE TO FOLLOW THESE INSTRUCTIONS MAY RESULT IN IMPROPER INSTALLATION, ADJUSTMENT, SERVICE OR MAINTENANCE POSSIBLY RESULTING IN FIRE, ELECTRICAL SHOCK, PROPERTY DAMAGE, PERSONAL INJURY OR DEATH.

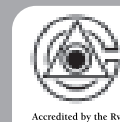

ISO 9001:2000

Certificate Number: 30164

DO NOT DESTROY THIS MANUAL

PLEASE READ CAREFULLY AND KEEP IN A SAFE PLACE FOR FUTURE REFERENCE BY A SERVICEMAN

TABLE OF CONTENTS

1.0 SAFETY INFORMATION	3
2.0 GENERAL INFORMATION	4
2.1 Checking Product Received	4
2.2 Application	4
2.3 Dimensions	5
2.4 Electrical and Physical Data	6
3.0 LOCATING UNIT	6
3.1 Corrosive Environment	6
3.2 Heat Pump Location	7
3.3 Operational Issues	7
3.4 For Units With Space Limitations	7
3.5 Customer Satisfaction Issues	8
3.6 Unit Mounting	8
3.7 Factory-Preferred Tie-Down Method	8
4.0 REFRIGERANT CONNECTIONS	9
5.0 REPLACEMENT UNITS	9
6.0 INDOOR COIL	10
6.1 Location	10
7.0 INTERCONNECTING TUBING	10
7.1 Vapor & Liquid Lines	10
7.2 Maximum Length of Lines	10
7.3 Vertical Separation	10
7.4 Tubing Installation	10
7.5 Tubing Connections	11
7.6 Leak Testing	12
8.0 DEMAND DEFROST CONTROL	13
8.1 Defrost Initiation	13
8.2 Defrost Termination	13
8.3 Temperature Sensors	14
8.4 Test Mode	14
8.5 Trouble Shooting Demand Defrost	14
9.0 EVACUATION PROCEDURE	14
10.0 START UP & PERFORMANCE	15
11.0 CHECKING AIRFLOW	15
12.0 CHECKING REFRIGERANT CHARGE	15
12.1 Charging By Liquid Pressure	15
12.2 Charging By Weight	16
12.3 Final Leak Testing	16
13.0 ELECTRICAL WIRING	16
13.1 Power Wiring	16
13.2 Grounding	17
13.3 Control Wiring	17
14.0 FIELD INSTALLED ACCESSORIES	17
14.1 Compressor Crankcase Heater	17
14.2 Low Ambient Control (LAC)	19
15.0 COMFORT CONTROL SYSTEM	19
15.1 Control Description	19
15.2 ICC Control Operation	21
15.3 Active Compressor Protection Mode	22
15.4 Test and Fault Recall Modes	22
16.0 SERVICE	24
16.1 Single-Pole Compressor Relay	24
17.0 TROUBLESHOOTING	27
17.1 Electrical Checks Flow Chart	27
17.2 Cooling Mechanical Checks Flow Chart	28
17.3 Heating Mechanical Checks Flow Chart	29
17.4 Defrost Mechanical Checks Flow Chart	30
17.5 Subcooling Calculation	31
17.6 General Troubleshooting Chart	32
17.7 Service Analyzer Chart	33
18.0 WIRING DIAGRAM	38

1.0 SAFETY INFORMATION

WARNING

These instructions are intended as an aid to qualified, licensed service personnel for proper installation, adjustment and operation of this unit. Read these instructions thoroughly before attempting installation or operation. Failure to follow these instructions may result in improper installation, adjustment, service or maintenance possibly resulting in fire, electrical shock, property damage, personal injury or death.

WARNING

The manufacturer's warranty does not cover any damage or defect to the air conditioner caused by the attachment or use of any components, accessories or devices (other than those authorized by the manufacturer) into, onto or in conjunction with the air conditioner. You should be aware that the use of unauthorized components, accessories or devices may adversely affect the operation of the air conditioner and may also endanger life and property. The manufacturer disclaims any responsibility for such loss or injury resulting from the use of such unauthorized components, accessories or devices.

WARNING

Disconnect all power to unit before starting maintenance. Failure to do so can cause electrical shock resulting in severe personal injury or death.

WARNING

Do not use oxygen to purge lines or pressurize system for leak test. Oxygen reacts violently with oil, which can cause an explosion resulting in severe personal injury or death.

WARNING

Turn off electric power at the fuse box or service panel before making any electrical connections.
Also, the ground connection must be completed before making line voltage connections. Failure to do so can result in electrical shock, severe personal injury or death.

WARNING

The unit must be permanently grounded. Failure to do so can cause electrical shock resulting in severe personal injury or death.

WARNING

Secure elevated unit and elevating stand in order to prevent tipping. Failure to do this may result in severe personal injury or death.

CAUTION

When coil is installed over a finished ceiling and/or living area, it is recommended that a secondary sheet metal condensate pan be constructed and installed under entire unit. Failure to do so may result in property damage.

CAUTION

Single-pole contactors are used on all standard single-phase units up through 5 tons. Caution must be exercised when servicing as only one leg of the power supply is broken with the contactor. Two pole contactors are used on some three phase units.

CAUTION

Dual fuel (fossil fuel) applications require the use of a high pressure control in the heat pump section. If a high pressure control was not originally provided with the heat pump section from the factory, a factory approved high pressure control kit must be purchased from the manufacturer and installed in the heat pump. Dual fuel (fossil fuel) applications in which a high pressure control is not installed in the outdoor heat pump section will void the safety approval of the product.

2.0 GENERAL

WARNING

The manufacturer's warranty does not cover any damage or defect to the air conditioner caused by the attachment or use of any components. Accessories or devices (other than those authorized by the manufacturer) into, onto or in conjunction with the air conditioner. You should be aware that the use of unauthorized components, accessories or devices may adversely affect the operation of the air conditioner and may also endanger life and property. The manufacturer disclaims any responsibility for such loss or injury resulting from the use of such unauthorized components, accessories or devices.

The information contained in this manual has been prepared to assist in the proper installation, operation and maintenance of the heat pump equipment. Improper installation, or installation not made in accordance with these instructions, can result in unsatisfactory operation and/or dangerous conditions, and can cause the related warranty not to apply.

Read this manual and any instructions packaged with separate equipment required to make up the system prior to installation. Retain this manual for future reference.

To achieve optimum efficiency and capacity, the indoor cooling coils listed in the heat pump specification sheet should be used.

2.1 CHECKING PRODUCT RECEIVED

Upon receiving unit, inspect it for any shipping damage. Claims for damage, either apparent or concealed, should be filed immediately with the shipping company. Check heat pump model number, electrical characteristics and accessories to determine if they are correct. Check system components to make sure they are properly matched.

2.2 APPLICATION

Before installing any heat pump equipment, a duct analysis of the structure and a heat gain calculation must be made. A heat gain calculation begins by measuring all external surfaces and openings that gain heat from the surrounding air and quantifying that heat gain. A heat gain calculation also calculates the extra heat load caused by sunlight and by humidity removal.

There are several factors that installers must consider.

- Outdoor unit location
- Proper equipment evacuation
- Refrigerant charge
- Indoor unit air flow
- Indoor unit blower speed
- Supply and return air duct design and sizing
- System air balancing
- Diffuser and return air grille location and sizing

MATCH ALL COMPONENTS:

- OUTDOOR UNIT
- INDOOR COIL/METERING DEVICE
- INDOOR AIR HANDLER/FURNACE
- REFRIGERANT LINES

2.3 DIMENSIONS (SEE FIGURE 1)

FIGURE 1
DIMENSIONS AND INSTALLATION CLEARANCES

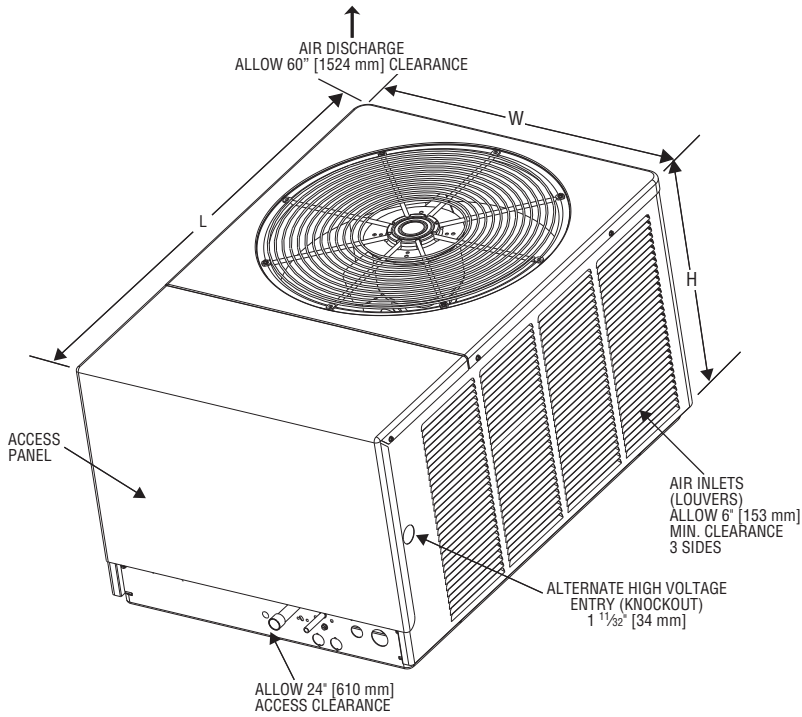

UNIT MODEL NUMBER EXPLANATION

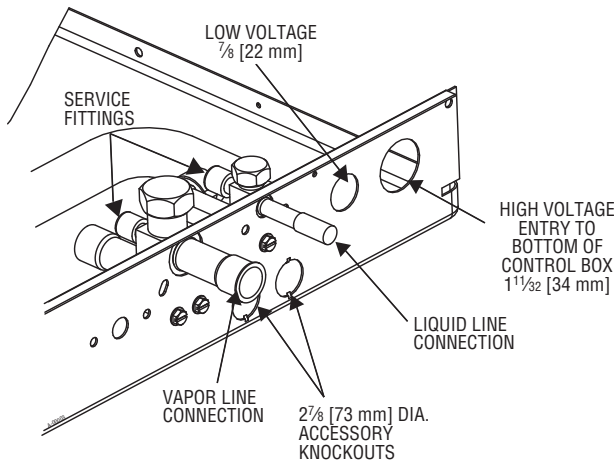
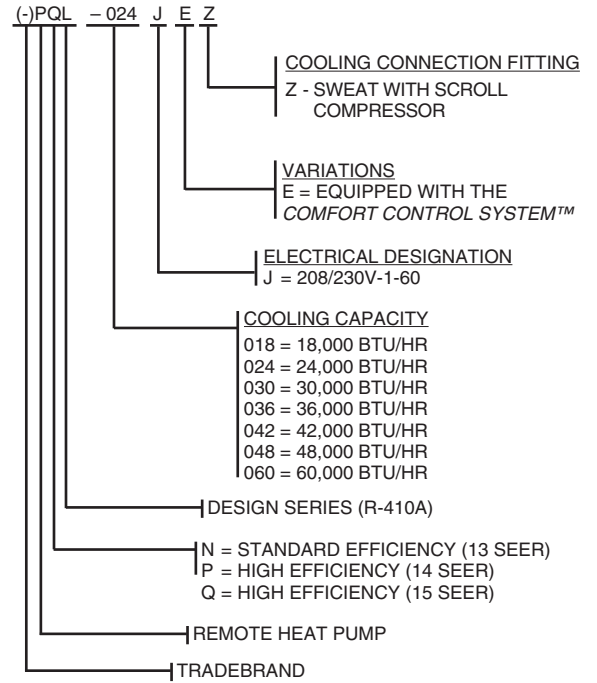

NOTE: SERVICE ACCESS TO ELECTRICAL & VALVES ALLOW 24" [610 mm] CLEARANCE ON SIDE

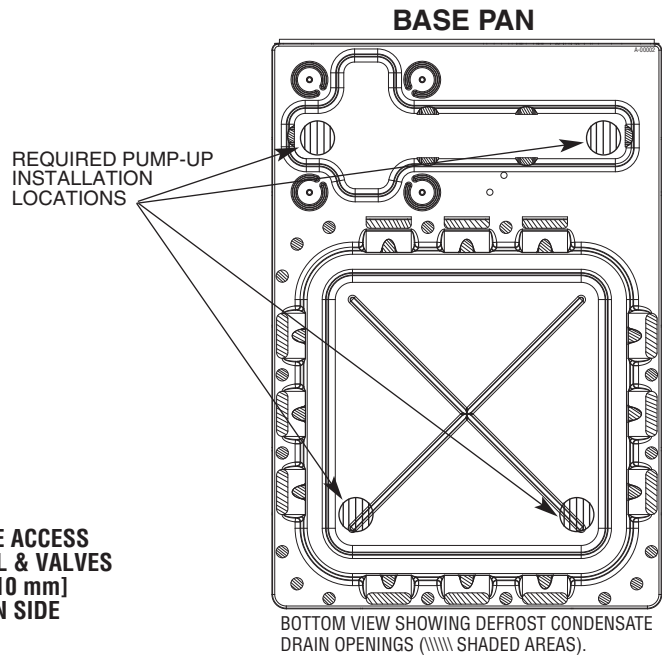

DIMENSIONAL DATA

(-)PQL	018JEZ	024JEZ	030JEZ, 036JEZ, 042JEZ	048JEZ, 060JEZ
HEIGHT "H" (INCHES) [mm]	19" [482]	19" [482]	25" [635]	33" [838]
LENGTH "L" (INCHES) [mm]	40-1/2" [1028]	44-3/8" [1127]	44-3/8" [1127]	44-3/8" [1127]
WIDTH "W" (INCHES) [mm]	27-5/8" [701]	31-1/2" [800]	31-1/2" [800]	31-1/2" [800]

2.4 ELECTRICAL & PHYSICAL DATA (SEE TABLE 1)

TABLE 1
(-)PQL ELECTRICAL AND PHYSICAL DATA

Electrical							Physical						
Model Number (-)PQL	Phase Frequency (Hz) Voltage (Volts)	Compressor		Fan Motor Full Load Amperes (FLA)	Minimum Circuit Ampacity Amperes	Fuse or HACR Circuit Breaker		Outdoor Coil			Refrig. Per Circuit Oz. [g]	Weight	
		Rated Load Amperes (RLA)	Locked Rotor Amperes (LRA)			Minimum Amperes	Maximum Amperes	Face Area Sq. Ft. [m ²]	No. Rows	CFM [L/s]		Net Lbs. [kg]	Shipping Lbs. [kg]
Rev. 11/7/2008													
018JEZ	60-208/230	9/9	48	0.8	18/18	15/15	20/20	11 [1.02]	1	1925 [908]	85 [2410]	156 [70.8]	166 [75.3]
024JEZ	60-208/230	13.5/13.5	58.3	0.8	18/18	25/25	30/30	13 [1.21]	1	1925 [908]	98 [2778]	156 [70.8]	167 [75.8]
030JEZ	60-208/230	14.1/14.1	73	0.8	19/19	25/25	30/30	17.1 [1.59]	1	1925 [908]	120 [3402]	175 [79.4]	186 [84.4]
036JEZ	60-208/230	17.5/17.5	79	0.8	23/23	30/30	40/40	33.6 [3.12]	1	3575 [1687]	194 [5500]	246 [111.6]	256 [116.1]
042JEZ	60-208/230	17.9/17.9	112	0.8	24/24	30/30	40/40	33.6 [3.12]	2	3575 [1687]	208 [5897]	256 [116.1]	266 [120.7]
048JEZ	60-208/230	19.9/19.9	109	0.8	26/26	35/35	45/45	44 [4.09]	2	3575 [1687]	231 [6549]	258 [117]	268 [121.6]
060JEZ	60-208/230	26.4/26.4	134	2.8	36/36	45/45	60/60	44 [4.09]	2	3100 [1463]	277 [7853]	308 [139.7]	318 [144.2]

3.0 LOCATING UNIT

3.1 CORROSIVE ENVIRONMENT

The metal parts of this unit may be subject to rust or deterioration if exposed to a corrosive environment. This oxidation could shorten the equipment's useful life. Corrosive elements include, but are not limited to, salt spray, fog or mist in seacoast areas, sulphur or chlorine from lawn watering systems, and various chemical contaminants from industries such as paper mills and petroleum refineries.

If the unit is to be installed in an area where contaminants are likely to be a problem, special attention should be given to the equipment location and exposure.

- Avoid having lawn sprinkler heads spray directly on the unit cabinet.
- In coastal areas, locate the unit on the side of the building away from the waterfront.
- Shielding provided by a fence or shrubs may give some protection, but cannot violate minimum airflow and service access clearances.
- Elevating the unit off its slab or base enough to allow air circulation will help avoid holding water against the basepan.

Regular maintenance will reduce the build-up of contaminants and help to protect the unit's finish.

WARNING

Disconnect all power to unit before starting maintenance. Failure to do so can cause electrical shock resulting in severe personal injury or death.

- Frequent washing of the cabinet, fan blade and coil with fresh water will remove most of the salt or other contaminants that build up on the unit.
- Regular cleaning and waxing of the cabinet with an automobile polish will provide some protection.
- A liquid cleaner may be used several times a year to remove matter that will not wash off with water.

Several different types of protective coil coatings are offered in some areas. These coatings may provide some benefit, but the effectiveness of such coating materials cannot be verified by the equipment manufacturer.

3.2 HEAT PUMP LOCATION

Consult local and national building codes and ordinances for special installation requirements. Following location information will provide longer life and simplified servicing of the outdoor heat pump.

NOTE: These units must be installed outdoors. No ductwork can be attached, or other modifications made, to the discharge grille. Modifications will affect performance or operation.

3.3 OPERATIONAL ISSUES

- **IMPORTANT:** Locate the unit in a manner that will not prevent, impair or compromise the performance of other equipment horizontally installed in proximity to the unit. Maintain all required minimum distances to gas and electric meters, dryer vents, exhaust and inlet openings. In the absence of National Codes, or manufacturers' recommendations, local code recommendations and requirements will take precedence.
- Refrigerant piping and wiring should be properly sized and kept as short as possible to avoid capacity losses and increased operating costs.
- Locate the unit where water run off will not create a problem with the equipment. Position the unit away from the drip edge of the roof whenever possible. Units are weatherized, but can be affected by the following:
 - o Water from the junction of rooflines, without protective guttering, entering the heat pump while in operation, can impact fan blade or motor life. Coil damage may occur to a heat pump if moisture cannot drain from the unit under freezing conditions.
 - o Freezing moisture, or sleeting conditions, can cause the cabinet to ice-over prematurely and prevent heat pump operation, requiring backup heat, which generally results in less economical operation.
- Closely follow clearance recommendations (see Figure 1).
 - o 24" to the service panel access
 - o 60" above heat pump fan discharge (unit top) to prevent recirculation
 - o 6" to heat pump coil grille air inlets (per heat pump).

3.4 FOR UNITS WITH SPACE LIMITATIONS

In the event that a space limitation exists, we will permit the following clearances:

Single Unit Applications: Heat pump grille side clearances below 6 inches will reduce unit capacity and efficiency. Do not reduce the 60-inch discharge, or the 24-inch service clearances.

Multiple Unit Applications: When multiple heat pump grille sides are aligned, a 6-inch per unit clearance is recommended, for a total of 12 inches between multiple units. Two combined clearances below 12 inches will reduce capacity and efficiency. Do not reduce the 60-inch discharge, or 24-inch service clearances.

- Do not obstruct the bottom drain opening in the heat pump base pan. It is essential to provide defrost condensate drainage to prevent possible refreezing of the condensation. Provide a base pad for mounting the unit, which is slightly pitched away from the structure. Route condensate off the base pad to an area which will not become slippery and result in personal injury.
- Where snowfall is anticipated, the heat pump must be elevated above the base pad to prevent ice buildup that may crush the tubing of the heat pump coil or cause fin damage. Heat pump units should be mounted above the average expected accumulated snowfall for the area.

FIGURE 2
RECOMMENDED ELEVATED INSTALLATION

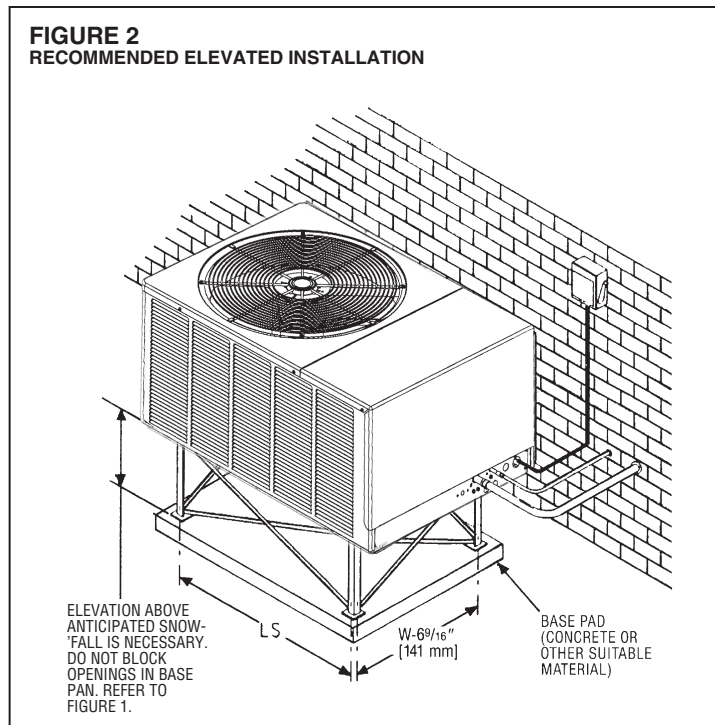

3.5 CUSTOMER SATISFACTION ISSUES

- The heat pump should be located away from the living, sleeping and recreational spaces of the owner and those spaces on adjoining property.
- To prevent noise transmission, the mounting pad for the outdoor unit should not be connected to the structure, and should be located sufficient distance above grade to prevent ground water from entering the unit.

3.6 UNIT MOUNTING

If elevating the heat pump, either on a flat roof or on a slab, observe the following guidelines. (See Figure 2.)

- The base pan provided elevates the heat pump 3/4" above the base pad.
- If elevating a unit on a flat roof, use 4" x 4" (or equivalent) stringers positioned to distribute unit weight evenly and prevent noise and vibration.

NOTE: Do not block drain openings shown in Figure 1.

- If unit must be elevated because of anticipated snow fall, secure unit and elevating stand such that unit and/or stand will not tip over or fall off.

⚠ CAUTION

Secure elevated unit and elevating stand in order to prevent tipping. Failure to do this may result in minor or moderate injury.

3.7 FACTORY-PREFERRED TIE-DOWN METHOD

INSTRUCTIONS

IMPORTANT: These instructions are intended as a guide to securing equipment for wind-load ratings of "120 MPH sustained wind load" and "3-second, 150 MPH gust." While this procedure is not mandatory, the Manufacturer does recommend that equipment be properly secured in areas where high wind damage may occur.

STEP 1: Before installing, clear pad of any dirt or debris.

IMPORTANT: The pad must be constructed of industry-approved materials, and must be thick enough to accommodate the concrete fastener.

STEP 2: Center base pan on pad, ensuring it is level.

STEP 3: Using basepad as a guide, mark spots on concrete where 4 holes will be drilled (see Figure 3).

STEP 4: Drill four pilot holes in pad, ensuring that the hole is at least 1/4" deeper than the concrete screw being used.

STEP 5: Center basepan over pre-drilled holes and insert concrete screws.

STEP 6: Tighten concrete screws.

NOTE: Do not over-tighten the concrete screws. Doing so can weaken the integrity of the concrete screw and cause it to break.

STEP 7: Finish unit assembly per unit's installation instructions.

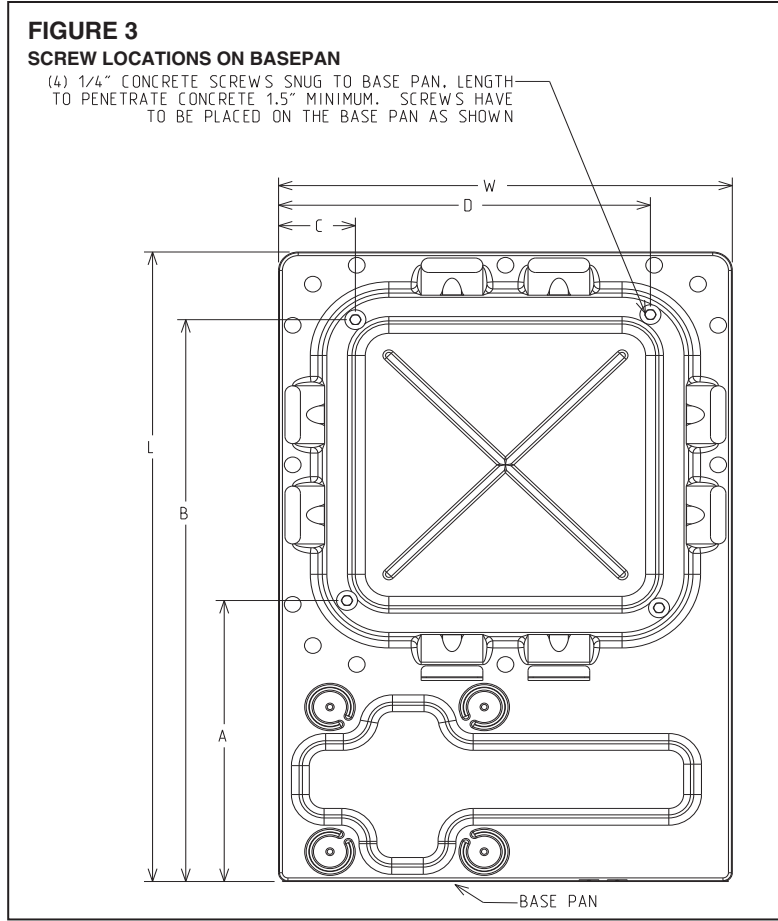

TABLE 2
BASEPAN DIMENSIONS

MODEL NUMBER	L	W	A	B	C	D
(-)PQL-018	37.625"	25.938"	15"	34"	3.5"	22.5"
(-)PQL-024, 030, 036, 042, 048, 60	41.5"	29.813"	15"	38"	3.5"	26.5"

4.0 REFRIGERANT CONNECTIONS

All units are factory charged with Refrigerant 410A. All models are supplied with service valves. Keep tube ends sealed until connection is to be made to prevent system contamination.

5.0 REPLACEMENT UNITS

To prevent failure of a new heat pump unit, the existing tubing system must be correctly sized and cleaned or replaced. Care must be exercised that the expansion device is not plugged. For new and replacement units, a liquid line filter drier should be installed and refrigerant tubing should be properly sized. Test the oil for acid. If positive, a liquid line filter drier is mandatory.

6.0 INDOOR COIL

REFER TO INDOOR COIL MANUFACTURER'S INSTALLATION INSTRUCTIONS.

IMPORTANT: The manufacturer is not responsible for the performance and operation of a mismatched system, or for a match listed with another manufacturer's coil.

6.1 LOCATION

Do not install the indoor coil in the return duct system of a gas or oil furnace. Provide a service inlet to the coil for inspection and cleaning. Keep the coil pitched toward the drain connection.

CAUTION

When coil is installed over a finished ceiling and/or living area, it is recommended that a secondary sheet metal condensate pan be constructed and installed under entire unit. Failure to do so may result in property damage.

7.0 INTERCONNECTING TUBING

7.1 VAPOR AND LIQUID LINES

Keep all lines sealed until connection is made.

Make connections at the indoor coil first.

Refer to Line Size Information in Table 3 and 4 for correct size and multipliers to be used to determine capacity for various vapor line diameters and lengths of run. The losses due to the lines being exposed to outdoor conditions are not included.

The factory refrigeration charge in the outdoor unit is sufficient for 15 feet of interconnecting lines. The factory refrigeration charge in the outdoor unit is sufficient for the unit and 15 feet of standard size interconnecting liquid and vapor lines. For different lengths, adjust the charge as indicated below.

1/4" ± .3 oz. per foot

5/16" ± .4 oz. per foot

3/8" ± .6 oz. per foot

1/2" ± 1.2 oz. per foot

7.2 MAXIMUM LENGTH OF LINES

The maximum length of interconnecting line is 150 feet. Always use the shortest length possible with a minimum number of bends. Additional compressor oil is not required for any length up to 150 feet.

NOTE: Excessively long refrigerant lines cause loss of equipment capacity.

7.3 VERTICAL SEPARATION

Keep the vertical separation to a minimum. Use the following guidelines when installing the unit:

1. DO NOT exceed the vertical separations as indicated on Table 4.
2. It is recommended to use the smallest liquid line size permitted to minimize system charge which will maximize compressor reliability.
3. Table 4 may be used for sizing horizontal runs.

7.4 TUBING INSTALLATION

Observe the following when installing correctly sized type "L" refrigerant tubing between the condensing unit and evaporator coil:

- If a portion of the liquid line passes through a hot area where liquid refrigerant can be heated to form vapor, insulating the liquid line is required.
- Use clean, dehydrated, sealed refrigeration grade tubing.
- Always keep tubing sealed until tubing is in place and connections are to be made.

- Blow out the liquid and vapor lines with dry nitrogen before connecting to the outdoor unit and indoor coil. Any debris in the line set will end up plugging the expansion device.
- As an added precaution, a high quality, bi-directional filter drier is recommended to be installed in the liquid line, if not factory installed.
- Do not allow the vapor line and liquid line to be in contact with each other. This causes an undesirable heat transfer resulting in capacity loss and increased power consumption. The vapor line must be insulated.
- If tubing has been cut, make sure ends are deburred while holding in a position to prevent chips from falling into tubing. Burrs such as those caused by tubing cutters can affect performance dramatically, particularly on small liquid line sizes.
- For best operation, keep tubing run as short as possible with a minimum number of elbows or bends.
- Locations where the tubing will be exposed to mechanical damage should be avoided. If it is necessary to use such locations, the copper tubing should be housed to prevent damage.
- If tubing is to be run underground, it must be run in a sealed watertight chase.
- Use care in routing tubing and do not kink or twist. Use a good tubing bender on the vapor line to prevent kinking.
- Route the tubing using temporary hangers, then straighten the tubing and install permanent hangers. Line must be adequately supported.
- The vapor line must be insulated to prevent dripping (sweating) and prevent performance losses. Armaflex and Rubatex are satisfactory insulations for this purpose. Use 1/2" minimum insulation thickness, additional insulation may be required for long runs.
- Check Table 3 for the correct vapor line size. Check Table 4 for the correct liquid line size.

7.5 TUBING CONNECTIONS

Indoor coils have only a holding charge of dry nitrogen. Keep all tube ends sealed until connections are to be made.

- Use type "L" copper refrigeration tubing. Braze the connections with accepted industry practices.
- Be certain both refrigerant shutoff valves at the outdoor unit are closed.
- Clean the inside of the fittings before brazing.
- Remove the cap and schrader core from service port to protect seals from heat damage.
- Use an appropriate heatsink material around the copper stub and the service valves before applying heat.
- **IMPORTANT:** Do not braze any fitting with the TEV sensing bulb attached.
- Braze the tubing between the outdoor unit and indoor coil. Flow dry nitrogen into a service port and through the tubing while brazing.
- The service valves are not backseating valves. To open the valves, remove the valve cap with an adjustable wrench. Insert a 3/16" or 5/16" hex wrench into the stem. Back out counterclockwise.
- Replace the valve cap finger tight then tighten an additional 1/2 hex flat for a metal-to-metal seal.

TABLE 3
SUCTION LINE LENGTH/SIZE VS. CAPACITY MULTIPLIER (R-410A)

Unit Size	1 1/2 Ton	2 Ton	2 1/2 Ton	3 Ton	3 1/2 Ton	4 Ton	5 Ton
Suction Line Connection Size	3/4" I.D.	3/4" I.D.	3/4" I.D.	7/8" I.D.	7/8" I.D.	7/8" I.D.	7/8" I.D.
Suction Line Run - Feet	5/8	5/8	5/8	3/4	3/4	7/8	7/8
	3/4*	3/4*	3/4*	7/8*	7/8*	1 1/8*	1 1/8*
	---	---	7/8	---	---	---	---
25'	Optional	1.00	1.00	1.00	1.00	1.00	1.00
	Standard	1.00	1.00	1.00	1.00	1.00	1.00
 Optional	---	---	1.00	---	---	---
50'	Optional	0.98	0.98	0.96	0.98	0.99	0.99
	Standard	0.99	0.99	0.98	0.99	0.99	0.99
 Optional	---	---	0.99	---	---	---
100'	Optional	0.95	0.95	0.94	0.96	0.96	0.97
	Standard	0.96	0.96	0.96	0.97	0.98	0.98
 Optional	---	---	0.97	---	---	---
150'	Optional	0.92	0.92	0.91	0.94	0.94	0.94
	Standard	0.93	0.94	0.93	0.95	0.96	0.97
 Optional	---	---	0.95	---	---	---

NOTES:
 *Standard Line Size
 Using suction line larger than shown in chart will result in poor oil return and is not recommended.

7.6 LEAK TESTING

- Pressurize line set and coil through service fittings with dry nitrogen to 150 PSIG maximum. Leak test all joints using liquid detergent. If a leak is found, relieve pressure and repair.

WARNING

Do not use oxygen to purge lines or pressurize system for leak test. Oxygen reacts violently with oil, which can cause an explosion resulting in severe personal injury or death.

TABLE 4
LIQUID LINE SIZING (R-410A)

System Capacity	Line Size Connection Size (Inch I.D.)	Line Size (Inch OD)	Liquid Line Size Outdoor Unit Above or Below Indoor Coil (Heat Pumps Only)					
			Total Equivalent Length - Feet					
			25	50	75	100	125	150
			Maximum Vertical Separation - Feet					
1 1/2 Ton	3/8"	1/4	25	40	25	9	N/A	N/A
		5/16	25	50	62	58	53	49
		3/8*	25	50	75	72	70	68
2 Ton	3/8"	1/4	23	N/A	N/A	N/A	N/A	N/A
		5/16	25	36	29	23	16	9
		3/8*	25	50	72	70	68	65
2 1/2 Ton	3/8"	1/4	25	N/A	N/A	N/A	N/A	N/A
		5/16	25	49	38	27	17	6
		3/8*	25	50	68	65	62	58
3 Ton	3/8"	5/16	25	50	37	22	7	N/A
		3/8*	25	50	68	63	58	53
3 1/2 Ton	3/8"	5/16	25	23	4	N/A	N/A	N/A
		3/8*	25	50	43	36	30	24
4 Ton	3/8"	3/8*	25	46	38	30	22	15
		1/2	25	50	56	55	53	52
5 Ton	3/8"	3/8	25	50	56	44	32	20
		1/2	25	50	75	81	79	76

NOTES:

*Standard Line Size.

N/A - Application not recommended.

8.0 DEMAND DEFROST CONTROL

The demand defrost control is a printed circuit board assembly consisting of solid state control devices with electro-mechanical outputs. The demand defrost control monitors the outdoor ambient temperature, outdoor coil temperature, and the compressor run-time to determine when a defrost cycle is required.

8.1 DEFROST INITIATION

A defrost will be initiated when the three conditions below are satisfied:

- 1) The outdoor coil temperature is below 35°F.
- 2) The compressor has operated for at least 34 minutes with the outdoor coil temperature below 35°F.
- 3) The measured difference between the ambient temperature and the outdoor coil temperature is greater than the calculated delta T.

Additionally, a defrost will be initiated if six hours of accumulated compressor run-time has elapsed without a defrost with the outdoor coil temperature below 35°F.

8.2 DEFROST TERMINATION

Once a defrost is initiated, the defrost will continue until fourteen minutes has elapsed or the coil temperature has reached the terminate temperature. The terminate temperature is factory set at 70°F, although the temperature can be changed to 50°F, 60°F, 70°F or 80°F by relocating a jumper on the board.

8.3 TEMPERATURE SENSORS

The coil sensor is clipped to the top tube on the outdoor coil at the point feed by the distribution tubes from the expansion device (short 3/8" dia. tube). The air sensor is located on the defrost control board.

If the ambient sensor fails the defrost control will initiate a defrost every 34 minutes with the coil temperature below 35°F.

If the coil sensor fails the defrost control will not initiate a defrost.

8.4 TEST MODE

The test mode is initiated by shorting the TEST pins. To initiate a manual defrost, short the TEST pins. Remove the short when the system switches to defrost mode. The defrost will terminate on time (14 minutes) or when the termination temperature has been achieved. Short TEST pins again to terminate the defrost immediately.

8.5 TROUBLE SHOOTING DEMAND DEFROST

Set the indoor thermostat select switch to heat and thermostat lever to a call for heat.

Jumper the "test pins" to put the unit into defrost. If the unit goes into defrost and comes back out of defrost, the indication is that the control is working properly.

If the unit did not go into defrost using the test pins, check to ensure that 24V is being supplied to the control board. If 24V is present then replace the control.

9.0 EVACUATION PROCEDURE

The life and efficiency of the equipment is dependent upon the thoroughness exercised by the technician when evacuating air and moisture from the system.

Air in the system causes high condensing temperatures and pressure, resulting in increased power input and non-verifiable performance.

Moisture chemically reacts with the refrigerant and oil to form corrosive hydrofluoric and hydrochloric acids. These attack motor windings and parts, causing breakdown.

After the system has been leak checked and proven sealed, connect the vacuum pump and evacuate system to 500 microns. The vacuum pump must be connected to both the high and low sides of the system through adequate connections. Use the largest size connections available since restrictive service connections may lead to false readings because of pressure drop through the fittings.

IMPORTANT: Compressors (especially scroll type) should never be used to evacuate the heat pump system because internal electrical arcing may result in a damaged or failed compressor.

10.0 START UP AND PERFORMANCE

Even though the unit is factory-charged with Refrigerant R-410A, the charge must be checked to the charge table on the service panel and adjusted, if required. (See Table 1.) Allow the unit to run for a minimum of five minutes. Before analyzing charge, see the instructions on the unit service panel rating plate for marking the total charge.

11.0 CHECKING AIRFLOW

The air distribution system has the greatest effect on airflow. The duct system is totally controlled by the contractor. For this reason, the contractor should use only industry-recognized procedures.

Heat pump systems require a specified airflow. Each ton of cooling requires between 350 and 450 cubic feet of air per minute (CFM), or 400 CFM nominally.

Duct design and construction should be carefully done. System performance can be lowered dramatically through bad planning or workmanship.

Air supply diffusers must be selected and located carefully. They must be sized and positioned to deliver treated air along the perimeter of the space. If they are too small for their intended airflow, they become noisy. If they are not located properly, they cause drafts. Return air grilles must be properly sized to carry air back to the blower. If they are too small, they also cause noise.

The installers should balance the air distribution system to ensure proper quiet airflow to all rooms in the home. This ensures a comfortable living space.

An air velocity meter or airflow hood can give a reading of the system CFM's.

12.0 CHECKING REFRIGERANT CHARGE

Charge for all systems should be checked against the Charging Chart inside the access panel cover.

IMPORTANT: Do not operate the compressor without charge in system.

Addition of R-410A will raise pressures (vapor, liquid and discharge).

If adding R-410A raises both vapor pressure and temperature, the unit is over-charged.

IMPORTANT: Use industry-approved charging methods to ensure proper system charge.

12.1 CHARGING BY LIQUID PRESSURE

Liquid pressure method is used for charging systems in the cooling and heating mode. The service port on the liquid service valve (small valve) and suction (large valve) is used for this purpose.

Verify that the outdoor unit is running and the indoor air mover is delivering the maximum airflow for this system size. Read and record the outdoor ambient temperature. Read and record the liquid and suction pressures at the ports on the liquid and suction valves. If refrigerant lines are sized using the nameplate charge, the correct liquid pressure is found at the intersection of the suction pressure and the outdoor ambient.

1. Remove refrigerant charge if the liquid pressure is above the chart value.
2. Add refrigerant charge if the liquid pressure is below the chart value.

12.2 CHARGING BY WEIGHT

For a new installation, evacuation of interconnecting tubing and indoor coil is adequate; otherwise, evacuate the entire system. Use the factory charge shown in Tables 1 through 4 of these instructions or unit data plate. Note that charge value includes charge required for 15 ft. of standard size interconnecting liquid line. Calculate actual charge required with installed liquid line size and length using:

1/4" O.D. = .3 oz./ft.

5/16" O.D. = .4 oz./ft.

3/8" O.D. = .6 oz./ft.

1/2" O.D. = 1.2 oz./ft.

With an accurate scale (+/- 1 oz.) or volumetric charging device, adjust charge difference between that shown on the unit data plate and that calculated for the new system installation. If the entire system has been evacuated, add the total calculated charge.

12.3 FINAL LEAK TESTING

After the unit has been properly evacuated and charged, a halogen leak detector should be used to detect leaks in the system. All piping within the condensing unit, evaporator, and interconnecting tubing should be checked for leaks. If a leak is detected, the refrigerant should be recovered before repairing the leak. The Clean Air Act prohibits releasing refrigerant into the atmosphere.

13.0 ELECTRICAL WIRING

WARNING

Turn off electric power at the fuse box or service panel before making any electrical connections.

Also, the ground connection must be completed before making line voltage connections. Failure to do so can result in electrical shock, severe personal injury or death.

CAUTION

Single-pole contactors are used on all standard single-phase units up through 5 tons. Caution must be exercised when servicing as only one leg of the power supply is broken with the contactor.

Field wiring must comply with the National Electric Code (C.E.C. in Canada) and any applicable local code.

13.1 POWER WIRING

It is important that proper electrical power from a commercial utility is available at the condensing unit contactor. Voltage ranges for operation are shown in Table 5.

Install a branch circuit disconnect within sight of the unit and of adequate size to handle the starting current (see Table 1).

Power wiring must be run in a rain-tight conduit. Conduit must be run through the connector panel below the access cover (see Figure 1) and attached to the bottom of the control box.

Connect power wiring to control located in outdoor condensing unit electrical box. (See wiring diagram attached to unit access panel.)

Check all electrical connections, including factory wiring within the unit and make sure all connections are tight.

DO NOT connect aluminum field wire to the contactor terminals.

TABLE 5
VOLTAGE RANGES (60 HZ)

Nameplate Voltage	Operating Voltage Range at Copeland Maximum Load Design Conditions for Compressors
208/230 (1 Phase)	187 - 253

13.2 GROUNDING

A grounding lug is provided near the control for a ground wire.

WARNING

The unit must be permanently grounded. Failure to do so can cause electrical shock resulting in severe personal injury or death.

13.3 CONTROL WIRING

(See Figure 4)

If the low voltage control wiring is run in conduit with the power supply, Class I insulation is required. Class II insulation is required if run separate. Low voltage wiring may be run through the insulated bushing provided in the 7/8 hole in the base panel, up to and attached to the pigtails from the bottom of the control box. Conduit can be run to the base panel if desired by removing the insulated bushing.

NOTE: Use No. 18 AWG solid copper wire at a minimum. If the wire length between the thermostat and the unit is more than 100 ft., use 16 AWG solid copper wire to avoid excessive voltage drop.

A thermostat and a 24 volt, 40 VA minimum transformer are required for the control circuit of the condensing unit. The furnace or the air handler transformer may be used if sufficient. Verify the correct primary voltage tap is used on the transformer. Use Table 6 to size the 24 volt control wiring.

NOTE: Reference unit wiring diagram for detailed wiring instructions.

TABLE 6
FIELD WIRE SIZE FOR 24 VOLT THERMOSTAT CIRCUITS

Thermostat Load - Amps	SOLID COPPER WIRE - AWG.					
	3.0	16	14	12	10	10
2.5	16	14	12	12	10	10
2.0	18	16	14	12	12	10
	50	100	150	200	250	300
	Length of Run - Feet (1)					

(1) Wire length equals twice the run distance.

NOTE: Do not use control wiring smaller than No. 18 AWG between thermostat and outdoor unit.

14.0 FIELD INSTALLED ACCESSORIES

14.1 COMPRESSOR CRANKCASE HEATER (CCH)

While scroll compressors usually do not require crankcase heaters, there are instances when a heater should be added. Refrigerant migration during the off cycle can result in a noisy start up. Add a crankcase heater to minimize refrigeration migration, and to help eliminate any start up noise or bearing "wash out."

NOTE: The installation of a crankcase heater is recommended if the system charger exceeds the values in Tables 7 & 8.

FIGURE 4
CONTROL WIRING FOR AIR HANDLER

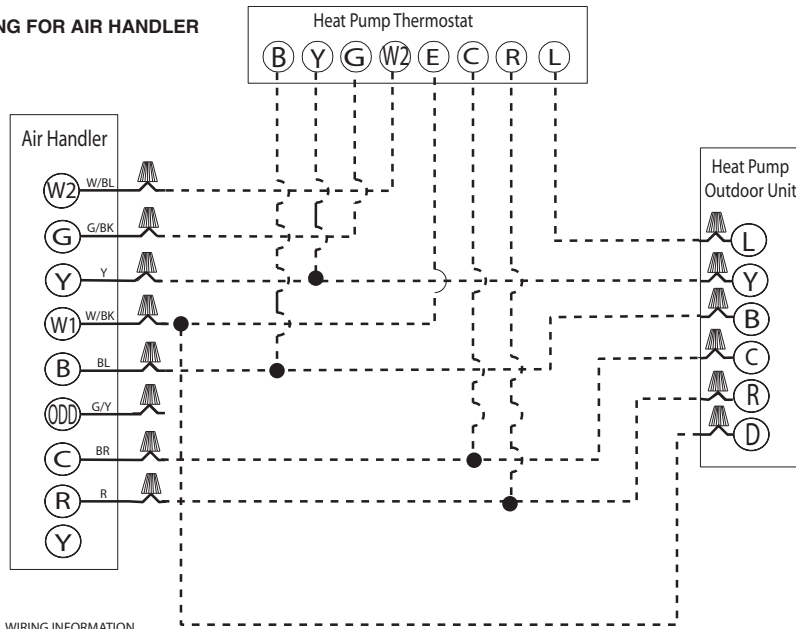

WIRING INFORMATION
Line Voltage
-Field Installed - - - -
-Factory Standard - - - -

NOTE: RED WIRE "R" REQUIRED AT HEAT PUMP.

NOTES:

1. Jumper "E" to "W2" to transfer control of supplemental heat to 1st stage when the emergency heat switch is on.
2. This wire turns on heat for defrost, omit for most economical operation.
3. Wire with colored tracing stripe.

TABLE 7
MAXIMUM SYSTEM CHARGE VALUES: (-)PQL

Model Size*	Compressor Model Number	Charge Limit Without Crankcase Heater
-018	ZP16K5E	9.6 lbs.
-024	ZP20K5E	9.6 lbs.
-030	ZP25K5E	9.6 lbs.

*036, 042, 048, 060 comes with the crankcase heater factory-installed.

All heaters are located on the lower half of the compressor shell. Its purpose is to drive refrigerant from the compressor shell during long off cycles, thus preventing damage to the compressor during start-up.

At initial start-up or after extended shutdown periods, make sure the heater is energized for at least 12 hours before the compressor is started. (Disconnect switch on and wall thermostat off.)

14.2 LOW AMBIENT CONTROL (LAC) – RXAD-A08

This component senses compressor head pressure and shuts the heat pump fan off when the head pressure drops to approximately 220 PSIG. This allows the unit to build a sufficient head pressure at lower outdoor ambient (down to 0°F) in order to maintain system balance and obtain improved capacity. Low ambient control should be used on all equipment operated below 70°F ambient.

CAUTION

FAILURE TO REMOVE CONDENSING UNIT COVER BEFORE OPERATING OUTDOOR UNIT CAN CAUSE COMPONENTS TO FAIL.

15.0 COMFORT CONTROL SYSTEM

The Integrated Compressor Control (ICC) is an integral part of the Comfort Control System and has the following features:

- Independent compressor and outdoor fan control
- Anti-short cycle protection (3 minute)
- Minimum unit run time (30 seconds)
- 7-segment LED to display status and diagnostics for faster service and accuracy
- High and low pressure switch monitoring
- Power and control voltage monitoring
- Active compressor protection integrated into the control
- Fault Recall capability with power loss memory
- Test Button allows unit operation for start-up diagnostics
- Can be used with a standard thermostat
- Flash diagnostic codes to room thermostat with L terminal
- Sealed compressor relay

15.1 CONTROL DESCRIPTION (SEE FIGURE 5)

7-Segment LED

- Displays status and diagnostic codes (See Status and Diagnostic Description)
- Displays diagnostic/fault recall (See Test Mode/Fault Recall)

CAUTION

UNIT MAY START SUDDENLY AND WITHOUT WARNING
Solid red light indicates a thermostat call for unit operation is present at the ICC control. ICC control will attempt to start unit after short cycle timer expires or when in Active Protection mode will attempt to restart unit prior to Lockout mode.

Red LED (Y1)

- Y1 red LED (solid on) indicates Y1 call from thermostat is present

Line Voltage Connector (ST1)

- Line voltage is connected to control board at Connector ST1
- Maximum wire size accepted is 6 AWG copper wire
- Torque terminals up to 20 in. lbs. max (Check wire terminations annually)

Compressor Wiring Connectors (ST2)

- Compressor wiring assembly is factory installed (Red – Run, Yellow – Start, Black – Common)

**FIGURE 5
ICC BOARD**

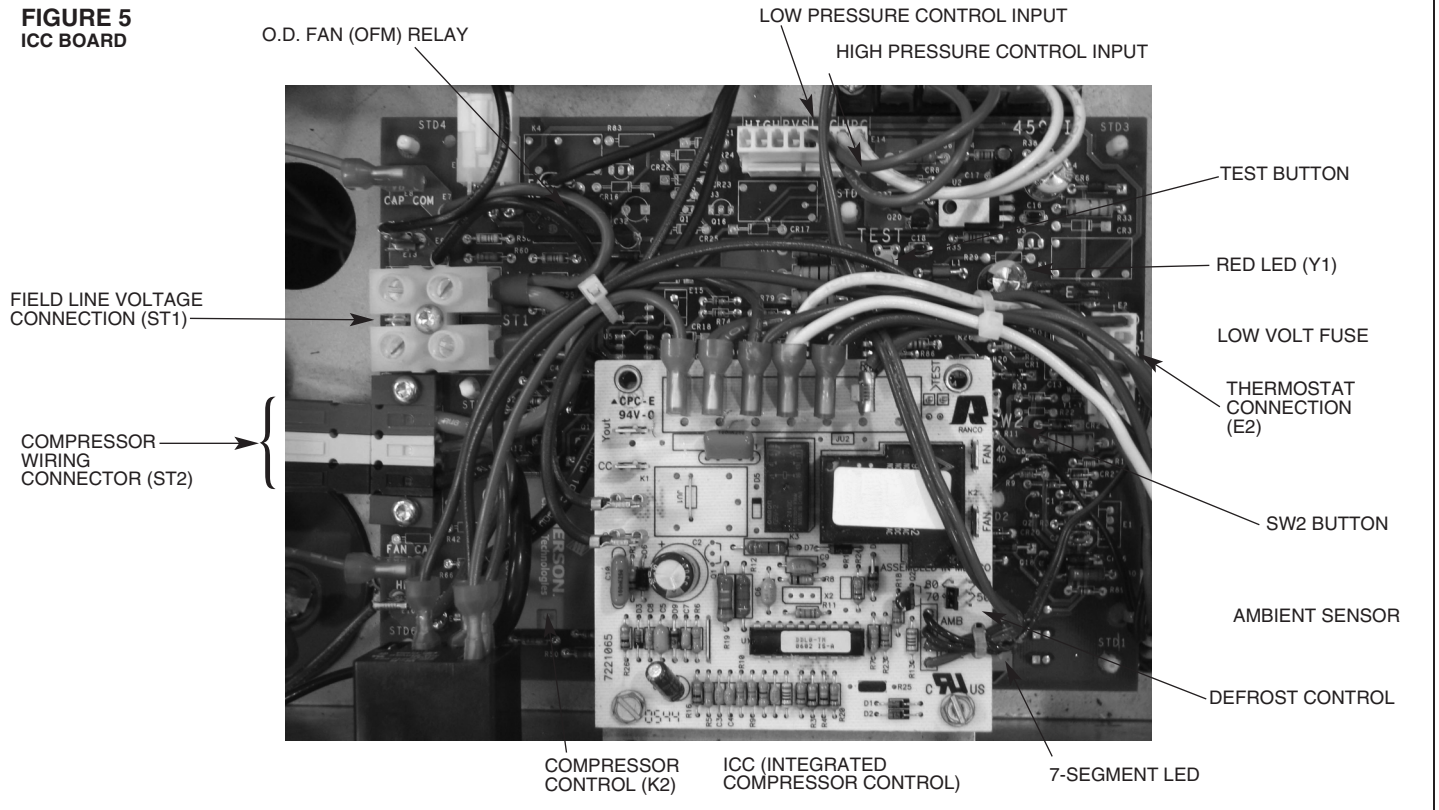

Compressor Control (K2)

- Sealed single pole compressor relay switch with optical feedback feature (arc detection)

Thermostat Connector (E2)

- **R** – 24VAC from the indoor unit 24VAC transformer (40 VA minimum)
- **C** – 24VAC Common from the indoor unit 24VAC transformer
- **Y1** – Call for unit operation (cooling)
- **L** – Communicate/flash diagnostic codes to an indoor thermostat that is enabled with an 'L' terminal, 'check service light', or similar function

L Terminal Output

- Flash 1 – Compressor running extremely long run cycle
- Flash 2 – Low or High pressure control trip
- Flash 3 – Unit short cycling
- Flash 5 – Compressor will not run
- Flash 8 – Control mis-operation
- Flash 9 – Low control voltage

Low Volt Fuse

- If required replace with 3 A automotive ATC style blade fuse

Low Pressure Control (LPC Input – E14)

- Low-pressure control is factory installed
- Low pressure control is an automatic resetting device

High Pressure Control (HPC Input – E14)

- High-pressure control is factory installed
- High pressure control is an automatic resetting device

Ambient Temperature Sensor

- Included on control but not required in the cooling only condenser application

TEST and SW2 Buttons

- TEST and SW2 buttons used to enter Test and Fault Recall Mode

15.2 ICC CONTROL OPERATION

Installation Verification

- 24V AC power on R and C must be present at the ICC for it to operate
- Line voltage must be present at the ICC for the compressor and the outdoor fan to operate
- When line and 24VAC control voltage is present and there is no Y1 call, or other diagnostics displayed, the control will display an “O” for standby mode
- If a Y1 call is initiated within 3 minutes of unit power-up or last compressor activation the control will display a flashing “c” and the red Led will activate to solid on

Call for Operation (Y1 Call)

- The ICC has an on/off fan delay of one (1) second.
- The ICC ignores state of LPC for 90 seconds upon compressor start
- The ICC will cause the compressor to be energized for 30 seconds minimum run time except when TEST button is pushed without a Y1 call

3-minute Anti-short Cycle Timer

- The ICC has a built in 3-minute time delay between compressor operations to protect the compressor against short cycling (Status flashing c).
- The 3-minute time delay can be bypassed when a Y1 call is present by pressing the TEST button for 1 second and releasing (Status solid on c).

30 Second Minimum Run Timer

- The ICC has a built in 30 second minimum unit run time (Status flashing c).

1 Second Compressor/Fan Delay

- The ICC starts/stops the outdoor fan 1 second after the start/stop of the compressor upon a Y1 call to minimize current inrush and/or voltage droop.

Low Pressure Control (LPC)

- Upon a Y1 call, if the ICC senses an open LPC it will not allow the compressor to be energized (diagnostic code 21).
- The ICC ignores the LPC for 90 seconds after the compressor is energized.
- After 90 seconds of compressor operation (Y1), the ICC responds to the state of the LPC.
- If the LPC opens after 90 seconds of compressor run time the ICC will stop the compressor, display a 21 on the seven-segment display, and flash a 2 on L terminal output
- If there is a Y1 call the compressor will restart upon automatic resetting of the low pressure switch and the 3-minute anti short cycle timer has expired
- **Active Protection** – If the LPC opens three (3) times during the same call (Y1) in the cooling mode or three (3) times within 120 minutes of operation in the heating mode, the ICC will lockout the compressor to keep it from operating and flash a “L21” on the seven-segment display and continue to flash a “2” on the “L” terminal output. In the heating mode, if the low pressure lock-out occurs at an outdoor ambient temperature below 5°F, the ICC will automatically exit the lockout mode when the outdoor temperature rises to 5°F. This feature is necessary since the low pressure control could simply have opened due to the outdoor ambient temperature being very low rather than an actual system fault.

High Pressure Control (HPC)

- Upon Y1 call, the ICC responds to the state of the HPC.
- If the HPC opens during a Y1 call the ICC will stop the compressor, flash a 23 on the seven-segment display, and flash a 2 on L terminal output
- If there is a Y1 call the compressor will restart upon automatic resetting of the high pressure switch and the 3-minute anti short cycle timer has expired
- **Active Protection** – If the HPC opens three (3) times during the same call (Y1), the ICC will lockout the compressor to keep it from continuing to operate and flash a L23 on the seven-segment display and continue to flash a 2 on L terminal output.

15.3 ACTIVE COMPRESSOR PROTECTION MODE

Active Compressor Protection

- The ICC actively protects the compressor from harmful operation during a fault condition.
- The ICC will protect the compressor by locking out if it senses three (3) trips of either the low or high pressure control during the same Y1 call in cooling or within 120 minutes of operation in the heating mode. There are no additional retries after a pressure switch lockout **except** when the ICC enters a low pressure lock-out in the heating mode when the outdoor ambient temperature is below 5°F. In that case, the ICC will automatically exit the lock-out mode when the outdoor temperature rises to 5°F and the compressor will begin to operate. This feature is necessary since the low pressure control could simply have opened due to the outdoor ambient temperature being very low rather than an actual system fault.
- The ICC will de-energize the compressor if it senses a compressor fault (will try to restart the compressor for up to 6 hours before a lockout)

Exiting Active Compressor Protection Lockout

There are three methods to reset the ICC after an active protection lockout:

- Cycle line voltage to the unit
- Cycle 24VAC to the ICC (R or C connection)
- Push the TEST button down for 1 second and release (The ICC will attempt to start the unit when the **TEST** button is pressed and released)

15.4 TEST AND FAULT RECALL MODES

Test Mode (TEST Button)

- The TEST mode resets the ICC from any active protection lockout mode or bypasses the 3-minute anti-short cycle timer and energizes the unit
- To enter TEST mode press **TEST** button with an insulated probe for 1 second and then release:
 - o If a Y1 call is present and a flashing “c” is indicated on the 7-segment display, a “t” will momentarily flash on the 7-segment display, the unit will energize, and the display will change to a steady “c”
 - o If a Y1 call is not present a steady “t” appears on the 7-segment display and the unit will energize for a maximum of 5 seconds (times out)
- A Y1 call during TEST mode causes the ICC to exit **TEST** and enter a normal unit operation mode
- **Note:** If Y1 is present at the ICC upon exit from TEST mode the unit will continue to operate

Fault Recall Mode (TEST and SW2 Buttons)

- To enter **FAULT RECALL** mode press both **TEST** and **SW2** buttons at the same time with insulated probes for 1 second and release.
- Upon entering and exiting the **FAULT RECALL** mode, the top and bottom segments of the 7-segment display will be activated.
- The ICC control will automatically scroll through stored faults on the 7-segment display.
- Each fault is displayed one time with the top segment of the 7-segment display activated between faults.
- Each fault is displayed with the most recent fault displayed first.
- A maximum of six individual faults can be stored.
- A maximum of 3 consecutive identical faults are stored.
- A “0” will be displayed when no faults are stored.
- The ICC will automatically exit the **FAULT RECALL** mode after displaying stored faults.

Clear Fault History (TEST and SW2 Buttons)

- To clear **FAULT HISTORY** press both **TEST** and **SW2** buttons at the same time with insulated probes for 5 seconds and release.
- The top and bottom segments of the 7-segment display will be activated and flash to indicate the history has been cleared.

Status and Diagnostic Description

7 -Segment Display Code	Diagnostic Description	Status / Possible Cause -Troubleshooting Information
0	Standby	Standby - No call for operation
c	Y1	First Stage or Single Stage Unit Operation
c Flashing	Anti-Short Cycle Timer (3 minutes) or Minimum Run Timer (30 seconds)	Waiting for anti-short cycle timer to expire Waiting for minimum run timer to expire
F	ICC Board Fuse Open	1. Low voltage wiring damage or miswired
1 (*)	Compressor Running Extremely Long Run Cycle (Cooling mode only)	1. Low refrigerant charge 2. Air ducts have substantial leakage 3. Check thermostat operation 4. Dirty filter 5. Dirty outdoor coil
2 (*)	Pressure Control Trip (L terminal output only)	1. (See faults 21, L21, 23, L23)
21 (***)	Low Pressure Control Trip Note: Low-pressure control is ignored for 90 seconds after call for unit operation. Active Protection – The ICC will try to restart the unit after the pressure control automatically re-closes. Unit will try to restart 3 times in the same thermostat call for operation (Y1) before lockout (fault L21).	1. Unit is low on refrigerant charge 2. Indoor coil is frozen (cooling mode) 3. Dirty indoor coil or filter (cooling mode) 4. Indoor blower is not running (cooling mode) 5. TEV is not operating correctly
L21 (**)	Lockout - Low Pressure Control Trip (**)	LPC tripped three consecutive times in same thermostat call
23 (***)	High Pressure Control Trip Active Protection – The ICC will try to restart the unit after the pressure control automatically re-closes. Unit will try to restart 3 times in the same thermostat call for operation (Y1) before lockout (fault L23)	1. Outdoor coil is dirty (cooling mode) 2. Outdoor fan is not running (cooling mode) 3. Dirty indoor coil or filter (heat pump mode) 4. Liquid line restriction (filter drier blocked, etc.) 5. Excessive refrigerant charge
L23 (**)	Lockout - High Pressure Control Trip (**)	HPC tripped three consecutive times in same thermostat call
25	Outdoor Ambient Temperature Sensor	1. ICC board sensor damaged (ICC will continue to operate)
27	Abnormal Low Line or No Line Voltage (See unit nameplate for operating voltage)	1. Check incoming line voltage to the disconnect and unit 2. Check wiring connections
28	Abnormal High Line Voltage	1. Check line voltage
3 (*)	Short Cycling	1. Check thermostat for intermittent demand signal 2. Check thermostat location in zone (too close to discharge grill)

5 (*) (***)	Compressor will not run Active Protection – After detecting compressor will not run the ICC control will shut the unit down. The control will try to restart the unit every 5 minutes for 4 tries. After that, the ICC will attempt a restart every 20 minutes up to 6 hours.	<ol style="list-style-type: none"> 1. Check for damaged, miswired, or wrong run capacitor 2. Check for damaged or miswired start capacitor and relay 3. Check voltage levels at ICC board and compressor 4. Check for broken wires, loose connectors, or miswired 5. Check compressor motor windings for continuity 6. Check for open compressor internal protector 7. Check for excessive liquid refrigerant in compressor
L5 (**)	Lockout – Check Compressor (**)	After 6 hours of attempted unit restart ICC control
-	ICC Board Mis-operation	1. Check ICC board compressor relay
8 (*)	ICC Board Mis-operation (L terminal output only)	1. Check ICC board compressor relay
9 (*)	ICC Secondary Voltage Low (Less than 18V)	1. Check transformer for miswiring or overloading.

(*) – Indicates flash code will be an output on the ICC “L” terminal to the indoor thermostat “L” terminal. Unless a diagnostic/fault is manually cleared by cycling power or pressing the TEST button the flash code will continue at the L terminal for up to 20 seconds after the start of a successful call for unit operation.

L Terminal Output

- Flash 1 – Compressor running extremely long run cycle
- Flash 2 – Low or High pressure control trip
- Flash 3 – Unit short cycling
- Flash 5 – Compressor will not run
- Flash 8 – Control mis-operation
- Flash 9 – Low control voltage

(**) – Lockout modes are reset by either cycling line voltage, low voltage, or by pressing control **TEST** button for 1 second. The control will attempt to start the unit when the **TEST** button is pressed and released (See **TEST** button label)

(***) – **Caution: Indicates Active Protection. Unit will attempt to restart automatically.**

CAUTION

UNIT MAY START SUDDENLY AND WITHOUT WARNING

Solid red light indicates a thermostat call for unit operation is present at the ICC. ICC will attempt to start unit after short cycle timer expires or when in Active Protection mode will attempt to restart unit prior to Lockout mode.

NOTE: For Additional Questions or Comments concerning the ICC, call 1-888-923-2323.

16.0 SERVICE

16.1 SINGLE-POLE COMPRESSOR RELAY

Integrated Compressor Control Relay is a single-pole relay used on all single phase units up through 5 tons. Caution must be exercised when servicing as only one leg of the power supply is broken with the relay.

FIGURE 6
JEZ DIAGNOSTIC LABEL

Caution – UNIT MAY START SUDDENLY AND WITHOUT WARNING
 Solid red LED light indicates a thermostat call for unit operation is present at the ICC.
 ICC will attempt to start unit after short cycle timer expires or when in Active Protection mode will attempt to restart unit prior to Lockout mode.

7 - Segment Display Code	Diagnostic Description	Status / Possible Cause - Troubleshooting Information
0	Standby	Standby - No call for operation
c	Y1	First Stage or Single Stage Unit Operation
C	Y2	Second Stage Unit Operation (2-stage unit only)
c or C Flashing	Anti-Short Cycle Timer (3 minutes) or Minimum Run Timer (30 seconds)	Waiting for anti-short cycle timer to expire Waiting for minimum run timer to expire
d	Defrost	Heat Pump Defrost Operation
d Flashing	Abnormal Defrost Condition (Defrost control exceeds maximum defrost time)	1. Defrost control miswired 2. Faulty defrost control
F	ICC Fuse Open	1. Low voltage wiring damage or miswired
1 (*)	Compressor Running Extremely Long Run Cycle (Cooling mode only)	1. Low refrigerant charge 2. Air ducts have substantial leakage 3. Check thermostat operation 4. Y2 thermostat signal may not be connected (2-stage units only) 5. Dirty outdoor coil
2 (*)	Pressure Control Trip (L terminal output only)	1. (See faults 21, L21, 23, L23)
21 (***)	Low Pressure Control Trip Note: Low-pressure control is ignored for 90 seconds after call for unit operation. <u>Active Protection</u> – The ICC will try to restart the unit after the pressure control automatically re-closes. Unit will try to restart 3 times in the same thermostat call for operation (Y1) before lockout (fault L21).	1. Unit is low on refrigerant charge 2. Indoor coil is frozen (cooling mode) 3. Dirty indoor coil or filter (cooling mode) 4. Indoor blower is not running (cooling mode) 5. Outdoor coil is frozen (heat pump mode) 6. Outdoor fan is not running (heat pump mode) 7. TEV is not operating correctly
L21 (**)	Lockout - Low Pressure Control Trip (**)	LPC tripped three consecutive times in same thermostat call
23 (***)	High Pressure Control Trip <u>Active Protection</u> – The ICC will try to restart the unit after the pressure control automatically re-closes. Unit will try to restart 3 times in the same thermostat call for operation (Y1) before lockout (fault L23)	1. Outdoor coil is dirty (cooling mode) 2. Outdoor fan is not running (cooling mode) 3. Dirty indoor coil or filter (heat pump mode) 4. Indoor blower is not running (heat pump mode) 5. Liquid line restriction (filter drier blocked, etc.) 6. Excessive refrigerant charge
L23 (**)	Lockout - High Pressure Control Trip (**)	HPC tripped three consecutive times in same thermostat call
25	Outdoor Ambient Temperature Sensor	1. ICC sensor damaged (ICC will continue to operate)
27	Abnormal Low Line or No Line Voltage (See unit nameplate for operating voltage)	1. Check incoming line voltage to the disconnect and unit 2. Check wiring connections
28	Abnormal High Line Voltage	1. Check line voltage
3 (*)	Short Cycling	1. Check thermostat for intermittent demand signal 2. Check thermostat location in zone (too close to discharge grill)
5 (*) (***)	Compressor will not run <u>Active Protection</u> – After detecting compressor will not run the ICC will shut the unit down. The control will try to restart the unit every 5 minutes for 4 tries. After that, the ICC will attempt a restart every 20 minutes up to 6 hours.	1. Check for damaged, miswired, or wrong run capacitor 2. Check for damaged or miswired start capacitor and relay 3. Check voltage levels at ICC and compressor 4. Check for broken wires, loose connectors, or miswired 5. Check compressor motor windings for continuity 6. Check for open compressor internal protector 7. Check for excessive liquid refrigerant in compressor
L5 (**)	Lockout – Check Compressor (**)	Lockout after 6 hours of attempted restart
-	ICC Mis-operation	1. Check ICC compressor relay
8 (*)	ICC Mis-operation (L terminal output only)	1. Check ICC compressor relay
9 (*)	ICC Secondary Voltage Low (< 18V)	1. Check transformer for miswiring or overloading.

ICC – Integrated Compressor Control

- (*) – Indicates the display code will be flashed as an output on the ICC “L” terminal. For example 2 flashes (blinks) from the “L” terminal output indicates a pressure control trip.
- (**) – Lockout modes are reset by removing line voltage, low voltage, or by pressing control TEST button for 1 second. The control will attempt to start the unit when the TEST button is pressed and released (See TEST button label)
- (***) – Indicates Active Protection. Unit will attempt to restart automatically.

Red LED Display Code	Diagnostic Description	Status Information
Solid On	Call for Unit Operation	Y1 call is present from the room thermostat at the control

For Additional Questions or Comments concerning the ICC call 1-888-923-2323

92-102221-01-02

FIGURE 7
JEZ TEST & FAULT RECALL LABEL

TEST MODE MANUAL OPERATION (TEST)

The TEST mode resets the ICC (Integrated Compressor Control) from any lockout mode or bypasses compressor anti-short cycle delay timer. To enter TEST mode press TEST button with insulated probe for 1 second and then release. A "t" will display on the 7-segment display. The "t" will remain unless an error is detected or a call for Y1 is present (red LED Y1 is on). A call for Y1 during TEST causes the control to exit TEST and enter a normal unit operation mode. During TEST mode the ICC will continue to activate the unit for up to 5 seconds (times out). To exit TEST mode at anytime press TEST button with insulated probe for 1 second and release. Note: If Y1 is present the ICC will exit from TEST mode the and unit will continue to run.

FAULT RECALL OPERATION (TEST and SW2)

To enter FAULT RECALL mode press both TEST and SW2 buttons at the same time with insulated probes for 1 second and release. Upon entering and exiting the FAULT RECALL mode, the top and bottom segments of the 7-segment display will be activated. The ICC will automatically scroll through stored faults on the 7-segment display. Each fault is displayed one time with the top segment of the 7-segment display activated between faults. Each fault is displayed with the most recent fault displayed first. An "O" will be displayed when no faults are stored. The ICC will automatically exit the FAULT RECALL mode after displaying stored faults.

An example of one LPC fault and one HPC fault scrolled on the display is as shown below:



CLEAR FAULT HISTORY (TEST and SW2)

To clear FAULT HISTORY press both TEST and SW2 buttons at the same time with insulated probes for 5 seconds and release. The top and bottom segments of the 7-segment display will be activated and flash to indicate the history has been cleared.

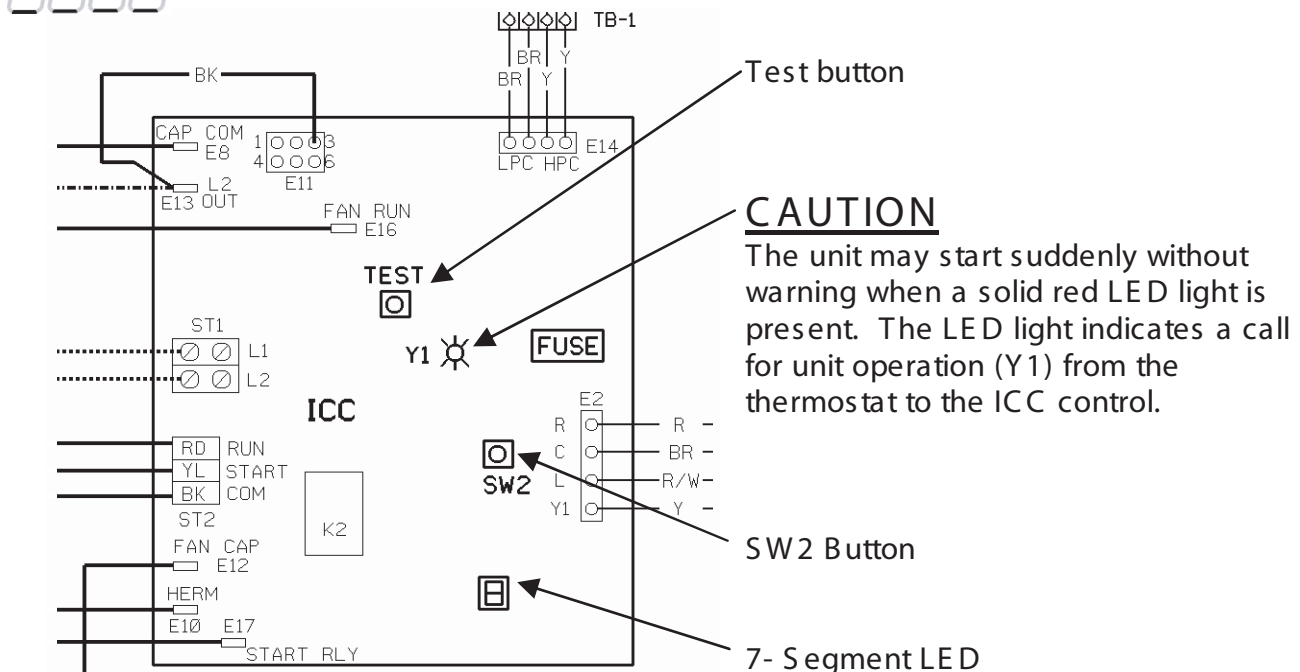

CAUTION
 The unit may start suddenly without warning when a solid red LED light is present. The LED light indicates a call for unit operation (Y1) from the thermostat to the ICC control.

17.0 TROUBLE SHOOTING

In diagnosing common faults in the heat pump system, develop a logical thought pattern as used by experienced technicians. The charts which follow are not intended to be an answer to all problems but only to guide the technician's thinking. Through a series of yes and no answers, follow the logical path to a likely conclusion.

A novice technician should use these charts like a road map. Remember that the chart should clarify a logical path to the problem's solution.

17.1 ELECTRICAL CHECKS FLOW CHART

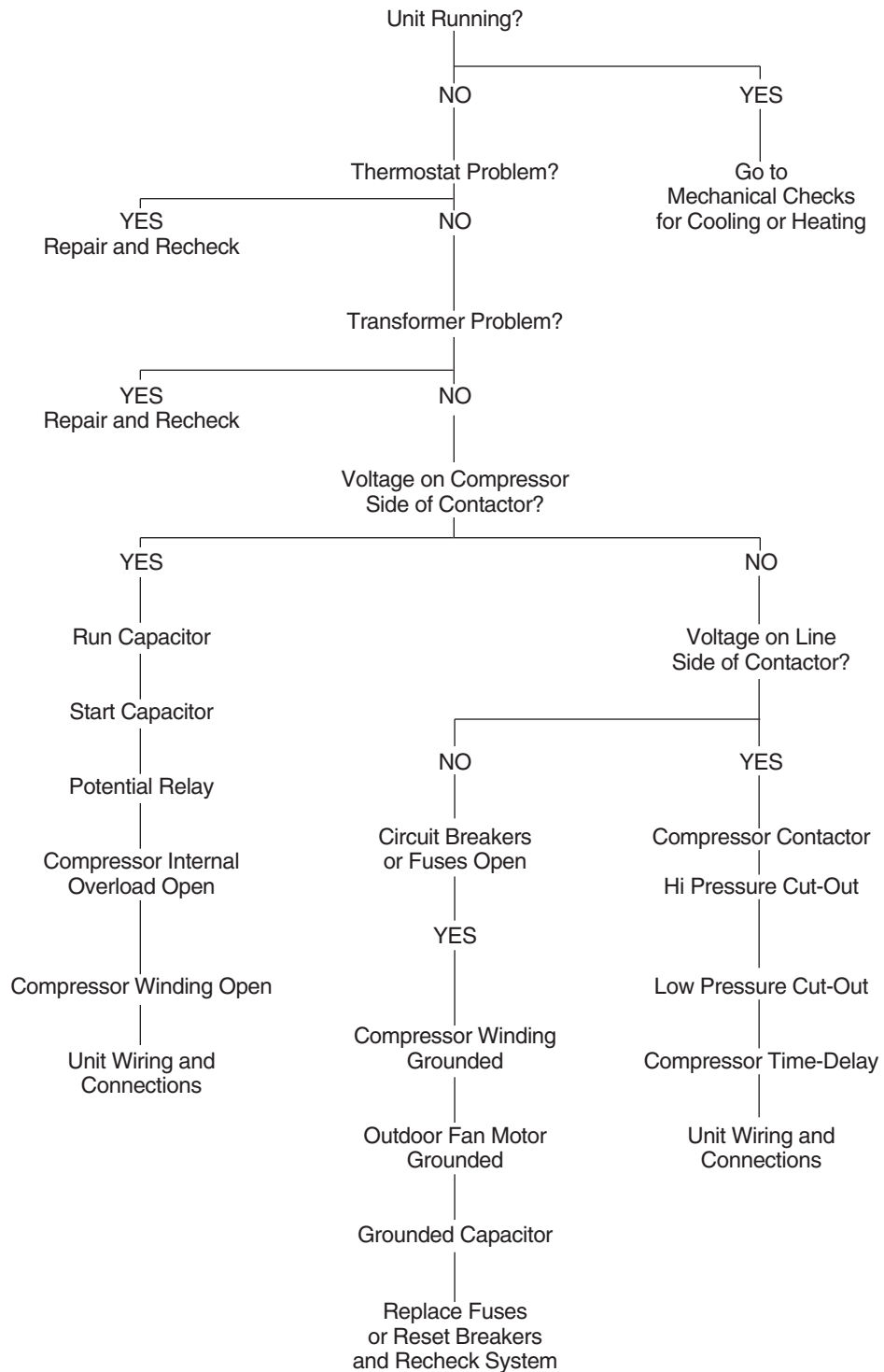

17.2 COOLING MECHANICAL CHECKS FLOW CHART

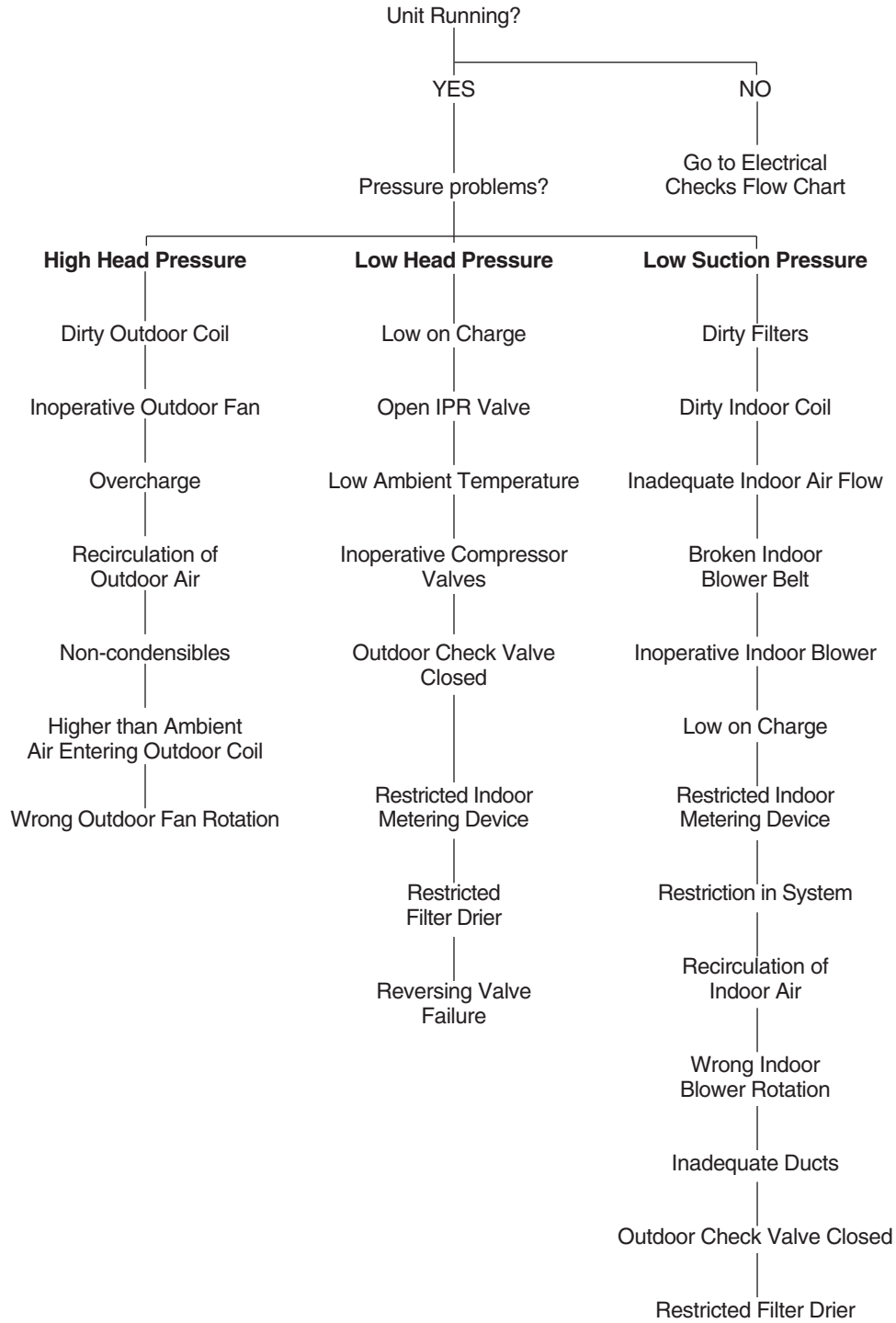

17.3 HEATING MECHANICAL CHECKS FLOW CHART

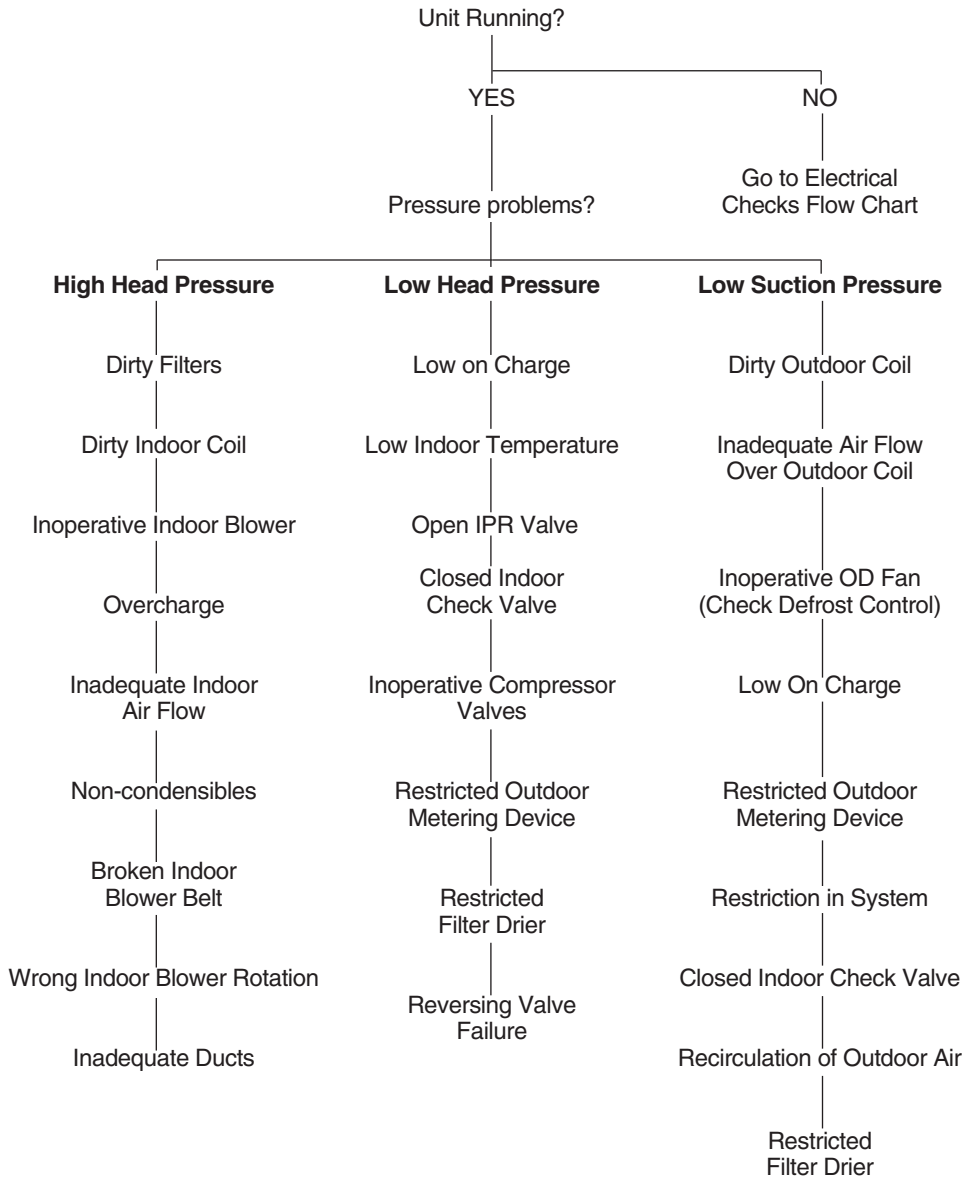

17.4 DEFROST MECHANICAL CHECKS FLOW CHART

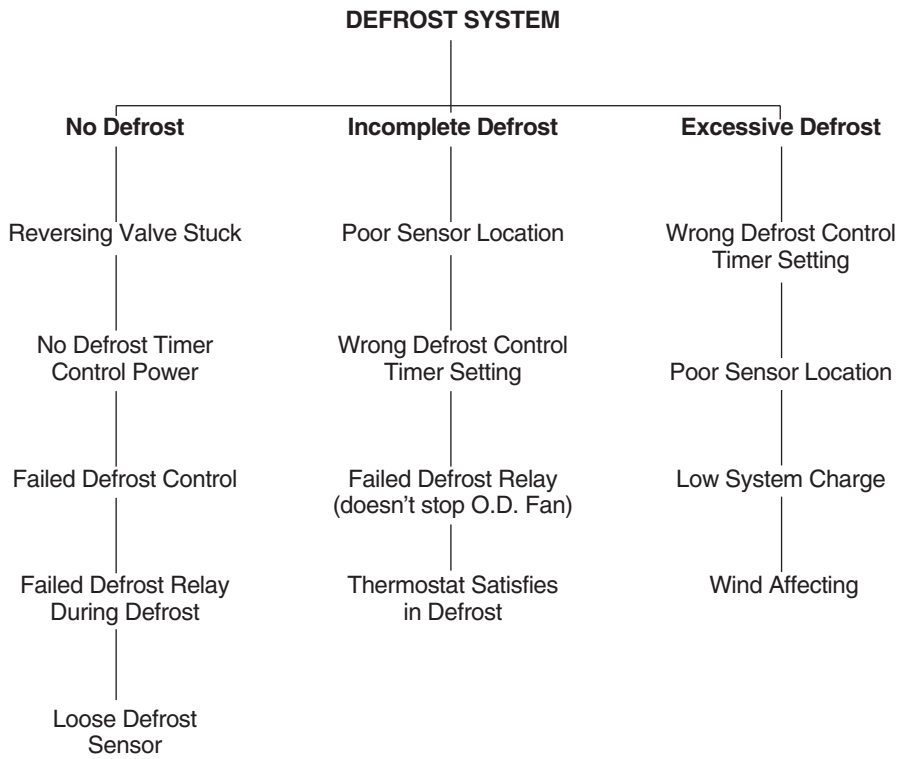

TABLE 8
TEMPERATURE PRESSURE CHART

TEMP (Deg. F)	R-410A PSIG
-150	—
-140	—
-130	—
-120	—
-110	—
-100	—
-90	—
-80	—
-70	—
-60	0.4
-50	5.1
-40	10.9
-35	14.2
-30	17.9
-25	22.0
-20	26.4
-15	31.3
-10	36.5
-5	42.2
0	48.4
5	55.1
10	62.4
15	70.2
20	78.5
25	87.5
30	97.2
35	107.5
40	118.5
45	130.2
50	142.7
55	156.0
60	170.1
65	185.1
70	201.0
75	217.8
80	235.6
85	254.5
90	274.3
95	295.3
100	317.4
105	340.6
110	365.1
115	390.9
120	418.0
125	446.5
130	476.5
135	508.0
140	541.2
145	576.0
150	612.8

17.5 SUBCOOLING CALCULATION

1. Measure the liquid pressure at the liquid line service valve.
2. Convert the liquid line pressure to saturated temperature. See Table 9.
3. Measure the liquid line temperature at the liquid line service valve.
4. Compare the liquid line temperature to the saturated temperature.
5. The difference between saturated temperature and liquid line temperature is the subcooling. Subcooling normal range 9° to 12°.

NOTE: The subcooling charging method should only be used in the cooling mode as the heating subcooling design level varies widely from one unit to the next while the cooling subcooling design level is fairly consistent at 8-12 degrees.

TABLE 9
HEAT PUMP SYSTEM TROUBLESHOOTING TIPS

HEAT PUMP SYSTEM TROUBLESHOOTING TIPS					
SYSTEM PROBLEM	INDICATORS				
	DISCHARGE PRESSURE	SUCTION PRESSURE	SUPERHEAT	SUBCOOLING	COMPRESSOR AMPS
Overcharge	High	High	Low	High	High
Undercharge	Low	Low	High	Low	Low
Liquid Restriction (Drier)	Low	Low	High	High	Low
Low Evaporator Airflow	Low	Low	Low	Low	Low
Dirty Heat Pump	High	High	Low	Low	High
Low Outside Ambient Temperature	Low	Low	High	High	Low
Inefficient Compressor	Low	High	High	High	Low
TEV Feeler Bulb Charge Lost	Low	Low	High	High	Low
Poorly Insulated Sensing Bulb	High	High	Low	Low	High

17.6 GENERAL TROUBLE SHOOTING CHART

▲ WARNING

Disconnect all power to unit before servicing. Contactor may break only one side. Failure to shut off power can cause electrical shock resulting in personal injury or death.

SYMPTOM	POSSIBLE CAUSE	REMEDY
Unit will not run	<ul style="list-style-type: none"> Power off or loose electrical connection Thermostat out of calibration-set too high Defective contactor Blown fuses / tripped breaker Transformer defective High pressure control open (if provided) Low pressure control open (if provided) 	<ul style="list-style-type: none"> Check for correct voltage at contactor in condensing unit Reset Check for 24 volts at contactor coil - replace if contacts are open Replace fuses / reset breaker Check wiring-replace transformer The high pressure control opens at 610 PSIG. Check for blocked coils, failed fan or blower motor, wiring issues, or defective high pressure control. The low pressure control opens at 25 PSIG. Check for low charge, blocked coils, wiring issues, or defective low pressure control.
Outdoor fan runs, compressor doesn't	<ul style="list-style-type: none"> Run or start capacitor defective Start relay defective Loose connection Compressor stuck, grounded or open motor winding, open internal overload. Low voltage condition 	<ul style="list-style-type: none"> Replace Replace Check for correct voltage at compressor - check & tighten all connections Wait at least 2 hours for overload to reset. If still open, replace the compressor. Add start kit components
Insufficient cooling	<ul style="list-style-type: none"> Improperly sized unit Improper indoor airflow Incorrect refrigerant charge Air, non-condensibles or moisture in system 	<ul style="list-style-type: none"> Recalculate load Check - should be approximately 400 CFM per ton. Charge per procedure attached to unit service panel Recover refrigerant, evacuate & recharge, add filter drier
Compressor short cycles	<ul style="list-style-type: none"> Incorrect voltage Defective overload protector Refrigerant undercharge 	<ul style="list-style-type: none"> At compressor terminals, voltage must be $\pm 10\%$ of nameplate marking when unit is operating. Replace - check for correct voltage Add refrigerant
Registers sweat	<ul style="list-style-type: none"> Low indoor airflow 	<ul style="list-style-type: none"> Increase speed of blower or reduce restriction - replace air filter
High head-low vapor pressures	<ul style="list-style-type: none"> Restriction in liquid line, expansion device or filter drier Flowcheck piston size too small Incorrect capillary tubes 	<ul style="list-style-type: none"> Remove or replace defective component Change to correct size piston Change coil assembly
High head-high or normal vapor pressure - Cooling mode	<ul style="list-style-type: none"> Dirty outdoor coil Refrigerant overcharge Outdoor fan not running Air or non-condensibles in system 	<ul style="list-style-type: none"> Clean coil Correct system charge Repair or replace Recover refrigerant, evacuate & recharge
Low head-high vapor pressures	<ul style="list-style-type: none"> Flowcheck piston size too large Defective Compressor valves Incorrect capillary tubes 	<ul style="list-style-type: none"> Change to correct size piston Replace compressor Replace coil assembly
Low vapor - cool compressor - iced indoor coil	<ul style="list-style-type: none"> Low indoor airflow Operating below 65°F outdoors Moisture in system 	<ul style="list-style-type: none"> Increase speed of blower or reduce restriction - replace air filter Add Low Ambient Kit Recover refrigerant - evacuate & recharge - add filter drier
High vapor pressure	<ul style="list-style-type: none"> Excessive load Defective compressor 	<ul style="list-style-type: none"> Recheck load calculation Replace
Fluctuating head & vapor pressures	<ul style="list-style-type: none"> TEV hunting Air or non-condensibles in system 	<ul style="list-style-type: none"> Check TEV bulb clamp - check air distribution on coil - replace TEV Recover refrigerant, evacuate & recharge
Gurgle or pulsing noise at expansion device or liquid line	<ul style="list-style-type: none"> Air or non-condensibles in system 	<ul style="list-style-type: none"> Recover refrigerant, evacuate & recharge

17.7 SERVICE ANALYZER CHARTS

COMPRESSOR OVERHEATING		
SYMPTOMS	POSSIBLE CAUSE	CHECK/REMEDIES
High superheat	Low charge	Check system charge
	Faulty metering device	Restricted cap tube, TEV (TXV)
		Power element superheat adjustment
		Foreign matter stopping flow
	High internal load	Hot air (attic) entering return
		Heat source on; mis-wired or faulty control
	Restriction in liquid line	Drier plugged
Line kinked		
Low head pressure	Low charge	
	Operating in low ambient temperatures	
Suction or liquid line subjected to high heat source	Hot attic	
	Hot water line	
Low voltage	Loose wire connections	Check wiring
	Dirty or pitted compressor contactor contacts	Replace contactor
	Power company problem, transformer	Have problem corrected before diagnosis continues
	Undersized wire feeding unit	Correct and complete diagnosis
High voltage	Power company problem	Have problem corrected
High head pressure	Overcharge	Check system charge
	Dirty heat pump coil	Clean coil
	Faulty or wrong size heat pump fan motor	Replace fan motor
	Faulty fan blade or wrong rotation	Replace fan blade
		Replace with correct rotation motor
	Recirculation of air	Correct installation
	Additional Heat Source	Check for dryer vent near unit
		Check for recirculation from other equipment
Non-condensibles	Recover refrigerant, Evacuate and recharge system	
Equipment not matched	Correct mis-match	
Short cycling of compressor	Faulty pressure control	Replace pressure control
	Loose wiring	Check unit wiring
	Thermostat	Located in supply air stream
		Differential setting too close
		Customer misuse
	TEV	Internal foreign matter
		Power element failure
		Valve too small
		Distributor tube/tubes restricted
	Capillary tube	Restricted with foreign matter
Kinked		
I.D. reduced from previous compressor failure		

SYMPTOMS	POSSIBLE CAUSE	CHECK OR REMEDIES
Short cycling of compressor (cont.)	Low charge	Check system charge
	Low evaporator air flow	Dirty coil
		Dirty filter
		Duct too small or restricted
	Faulty run capacitor	Replace
Faulty internal overload	Replace compressor	
Faulty Compressor Valves	Fast equalization/ Low pressure difference	Replace compressor and examine system to locate reason
<i>ELECTRICAL</i>		
SYMPTOMS	POSSIBLE CAUSE	CHECK OR REMEDIES
Voltage present on load side of compressor contactor and compressor won't run	Compressor start components	Check start capacitor
		Check potential relay
	Run capacitor	Check with ohmmeter
	Internal overload	Allow time to reset
Voltage present on line side of pressor contactor only	Compressor windings	Check for correct ohms
		Thermostat
	Compressor control circuit	High pressure switch
		Low pressure switch
		Ambient thermostat
	Solid state protection control or internal thermal sensors	
	Compressor timed off/on control or interlock	
No voltage on line side of compressor contactor	Blown fuses or tripped circuit breaker	Check for short in wiring or unit
	Improper wiring	Re-check wiring diagram
Improper voltage	High voltage	Wrong unit
		Power supply problem
	Low voltage	Wrong unit
		Power supply problem
		Wiring undersized
	Loose connections	
	Single Phasing (3 phase)	Check incoming power and fusing
<i>CONTAMINATION</i>		
SYMPTOMS	POSSIBLE CAUSE	CHECK OR REMEDIES
Moisture	Poor evacuation on installation or during service	In each case, the cure is the same. Recover refrigerant. Add filter drier, evacuate and re-charge
High head pressure	Non-condensibles air	
Unusual head and suction readings	Wrong refrigerant	
Foreign Matter- copper filings	Copper tubing cuttings	
Copper oxide	Dirty copper piping	
Welding scale	Nitrogen not used	
Soldering flux	Adding flux before seating copper part way	
Excess soft solder	Wrong solder material	

LOSS OF LUBRICATION		
SYMPTOMS	POSSIBLE CAUSE	CHECK OR REMEDIES
Compressor failures	Line tubing too long	Add oil to the recommended level
	Line tubing too large	Reduce pipe size to improve oil return
Low suction pressure	Low charge	Check system charge
	Refrigerant leaks	Repair and recharge
Cold, Noisy compressor - Slugging	Dilution of Oil with Refrigerant	Observe piping guidelines
Noisy compressor	Migration	Check crankcase heater
Cold, sweating compressor	Flooding	Check system charge
Low Load	Reduced air flow	Dirty filter
		Dirty coil
		Wrong duct size
		Restricted duct
Short cycling of compressor	Thermostat setting	Advise customer
	Faulty pressure control	Replace control
	Loose wiring	Check all control wires
	Thermostat	In supply air stream, out of calibration, Customer misuse
FLOODED STARTS		
SYMPTOMS	POSSIBLE CAUSES	CHECK OR REMEDIES
Liquid in the compressor shell	Faulty or missing crankcase heater	Replace crankcase heater
Too much liquid in system	Incorrect piping	Check Piping guidelines
	Overcharge	Check and adjust charge
SLUGGING		
SYMPTOMS	POSSIBLE CAUSES	CHECK OR REMEDIES
On start up	Incorrect piping	Review pipe size guidelines
TEV hunting when running	Oversized TEV	Check TEV application
FLOODING		
SYMPTOMS	POSSIBLE CAUSES	CHECK OR REMEDIES
Poor system control using a TEV	Loose sensing bulb	Secure the bulb and insulate
	Bulb in wrong location	Relocate bulb
	Wrong size TEV	Use correct replacement
	Improper superheat setting	Adjust, if possible; Replace, if not
Poor system control using capillary tubes	Overcharge	Check system charge
	High head pressures	Dirty heat pump
		Restricted air flow
Evaporator air flow too low	Recirculation of air	
	Adjust air flow to 350-400 CFM/Ton	

THERMOSTATIC EXPANSION VALVES

SYMPTOMS	POSSIBLE CAUSE	CHECK OR REMEDIES	
High Superheat, Low Suction Pressure	Moisture freezing and blocking valve	Recover charge, install filter-drier, evacuate system, recharge	
	Dirt or foreign material blocking valve	Recover charge, install filter-drier, evacuate system, recharge	
	Low refrigerant charge	Correct the charge	
	Vapor bubbles in liquid line	Remove restriction in liquid line	Correct the refrigerant charge
		Remove non-condensable gases	
		Size liquid line correctly	
	Misapplication of internally equalized valve	Use correct TEV	
	Plugged external equalizer line	Remove external equalizer line restriction	
	Undersized TEV	Replace with correct valve	
	Loss of charge from power head sensing bulb	Replace power head or complete TEV	
	Charge migration from sensing bulb to power head (Warm power head with warm, wet cloth. Does valve operate correctly now?)	Ensure TEV is warmer than sensing bulb	
Improper superheat adjustment (Only applicable to TEV with adjustable superheat settings)	Adjust superheat setting counter-clockwise		
Valve feeds too much refrigerant, with low superheat and higher than normal suction pressure	Moisture causing valve to stick open.	Recover refrigerant, replace filter-drier, evacuate system and then non-recharge	
	Dirt or foreign material causing valve to stick open	Recover refrigerant, replace filter-drier, evacuate system and recharge	
	TEV seat leak (A gurgling or hissing sound is heard AT THE TEV during the off cycle, if this is the cause.) NOT APPLICABLE TO BLEED PORT VALVES.	Replace the TEV	
	Oversized TEV	Install correct TEV	
	Incorrect sensing bulb location	Install bulb with two mounting straps, in 2:00 or 4:00 position on suction line, with insulation	
	Low superheat adjustment (only applicable to TEV with adjustable superheat setting)	Turn superheat adjustment clockwise	
	Incorrectly installed, or restricted external equalizer line	Remove restriction, or relocate external equalizer	
Compressor flood back upon start up	Refrigerant drainage from flooded evaporator	Install trap riser to the top of the evaporator coil	
	Compressor in cold location	Install crankcase heater on compressor	
	Any of the causes listed under Symptoms of Problem #2	Any of the solutions listed under Solutions of Problem #2	

THERMOSTATIC EXPANSION VALVES

SYMPTOMS	POSSIBLE CAUSE	CHECK OR REMEDIES
Superheat is low to normal with low suction pressure	Unequal evaporator circuit loading	Ensure air flow is equally distributed through evaporator
		Check for blocked distributor tubes
	Low load or airflow entering evaporator coil	Ensure blower is moving proper air CFM
		Remove/Correct any air flow restriction
Superheat and suction pressure fluctuate (valve is hunting)	Expansion valve is oversized	Install correct TEV
	Sensing bulb is affected by liquid refrigerant or refrigerant oil flowing through suction line	Relocate sensing bulb in another position around the circumference of the suction line
	Unequal refrigerant flow through evaporator circuits	Ensure sensing bulb is located properly
		Check for blocked distributor tubes
	Improper superheat adjustment (only possible with TEV having superheat adjustment)	Replace TEV or adjust superheat
	Moisture freezing and partially blocking TEV	Recover refrigerant, change filter-drier, evacuate system and recharge
Valve does not regulate at all	External equalizer line not connected or line plugged	Connect equalizer line in proper location, or remove any blockage
	Sensing bulb lost its operating charge	Replace TEV
	Valve body damaged during soldering or by improper installation	Replace TEV

18.0 WIRING DIAGRAM

FIGURE 8
SINGLE-PHASE WIRING DIAGRAM (-)PNL-***JEZ (208/230V SINGLE PHASE)

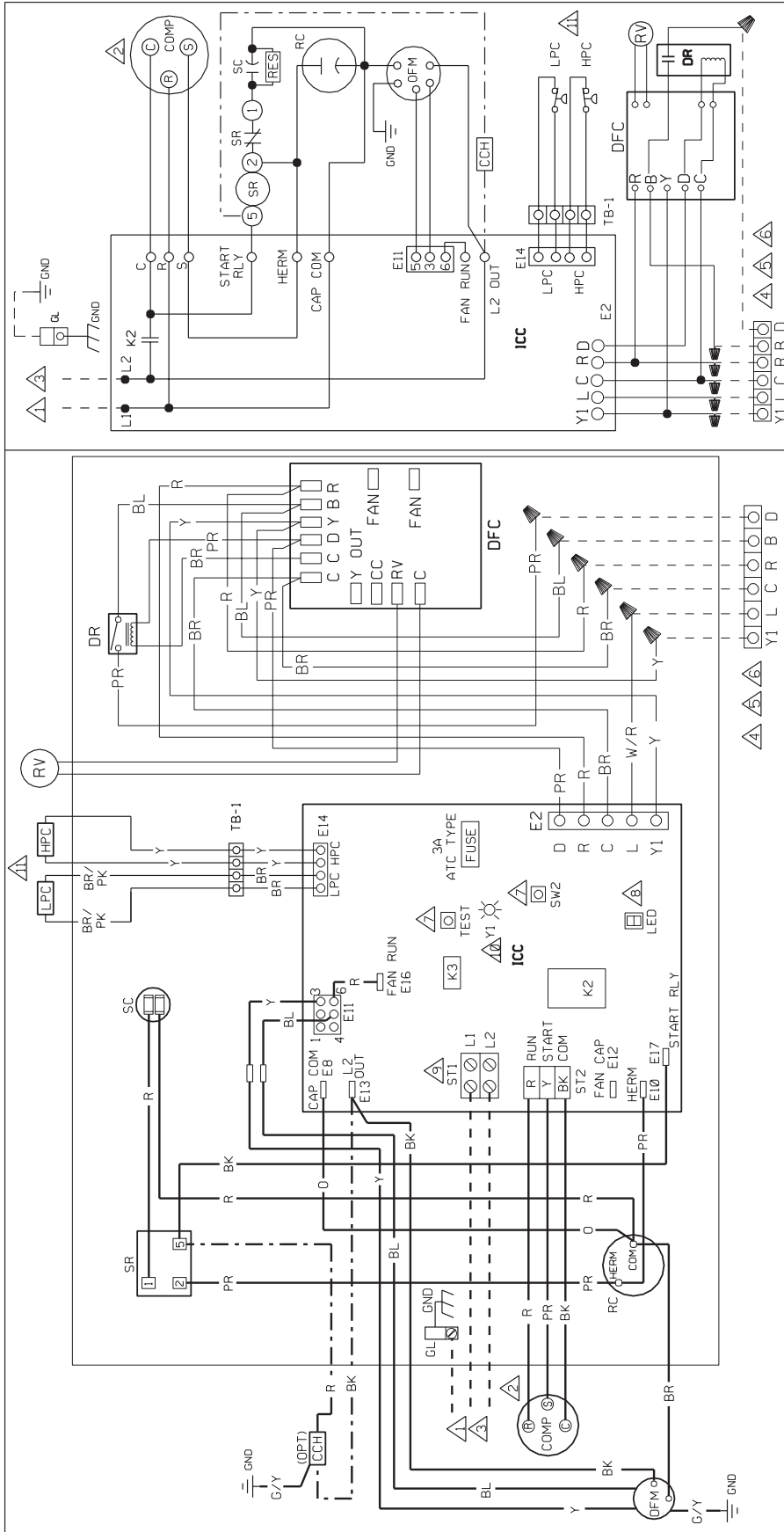

WIRE COLOR CODE	
BK	BLACK
BR	BROWN
BL	BLUE
G	GREEN
CY	GRAY
GR	ORANGE
O	WHITE
PK	PINK
R	RED
W	YELLOW
PR	PURPLE

ELECTRICAL WIRING DIAGRAM	
HEAT PUMP	
1 STAGE	
INTEGRATED COMPRESSOR CONTROL	
DR BY	APP. BY DATE
MGR	8-5-08
DWG. NO.	90-102074-02
REV	01

- NOTES:**
- CONNECTORS SUITABLE FOR USE WITH COPPER CONDUCTORS ONLY.
 - COMPRESSOR MOTOR THERMALLY PROTECTED.
 - CONNECT FIELD WIRING TO INCORPORATED MAINTENANCE CONDUIT TO FIELD AND PER NATIONAL AND LOCAL CODES.
 - LOW VOLTAGE CIRCUIT TO BE N.E.C. CLASS 2 WITH A CLASS 2 TRANSFORMER 24 VOLT, 500 OR 600 HERTZ, MIN 18 AWG.
 - TO THERMOSTAT REFER TO SYSTEM SCHEMATICS OR SCHEMATICS ON INDOOR SECTION FOR LOW VOLTAGE CONTROL WIRING.
 - L. OUTPUT USED ON CERTAIN MODEL THERMOSTATS WITH L TERMINAL.
 - TEST AND SERVICE PUSH BUTTONS USED FOR TEST AND SERVICE. DISCONNECT RELOC. SEE PUSH BUTTON LABEL FOR DETAILS.
 - 7-SEGMENT LED DISPLAY AS DIAGNOSTIC CODES.
 - SEE DIAGNOSTIC LABEL FOR DETAILS.
 - TORQUE REQUIREMENTS 20 IN-LB. CHECK ANNUALLY.
 - SOLID ON INDICATES Y1 CALL PRESENT AT ICC CONTROL.
 - LPC AND HPC ARE AUTOMATIC RESET SWITCHES.

COMPONENT CODE	
CCH	CRANK CASE HEATER
COMP	COMPRESSOR CONTROL
DFC	DEFROST CONTROL
DR	DEFROST RELAY
GL	GROUND LUG
GND	GROUND, CHASSIS
HPC	HIGH PRES.-CUT-OUT CONTROL
ICC	INTEGRATED COMPRESSOR CONTROL
LPC	LOW PRESSURE CONTROL
PC	COMPRESSOR MOTOR
RES	RESISTOR
RV	REVERSING VALVE
SC	START CAPACITOR
ST1	START RELAY BOARD POWER TERMINAL BLOCK
ST2	START RELAY BOARD COMPRESSOR WIRE TERMINAL BLOCK
TB	TERMINAL BLOCK

WIRING INFORMATION	
LINE VOLTAGE	STANDARD
-FACTORY OPTION	-FIELD INSTALLED
LOW VOLTAGE	STANDARD
-FACTORY OPTION	-FIELD INSTALLED
REPLACEMENT WIRE	MUST BE THE SAME SIZE AND TYPE OF INSULATION AS ORIGINAL (105 C° MIN.)
WARNING	-CABINET MUST BE PERMANENTLY GROUNDED AND CONFORM TO I.E.C., N.E.C., C.E.C. AND LOCAL CODES AS APPLICABLE.

DWG. NO.	
90-102074-02	
REV	01

