

HEAT PUMPS



RPNE- SERIES

Seven Models

13 SEER with efficiencies ranging up to 14 SEER in certain matched systems. Nominal Sizes 1 $\frac{1}{2}$ to 5 Tons [5.28 kW] to [17.58 kW]



The Rheem *Classic*® Series RPNE- Heat Pump Outdoor units can provide year-round heating and cooling comfort for residential, multi-family and light commercial applications. They are designed to operate with Rheem indoor units with cooling and heating capacities certified under the ARI Certification program.

The Rheem RHSA-, RHLA- & RHKA- Air Handlers are equipped with auxiliary heating elements for supplementary heat was designed especially for use with the RPNE- Heat Pump. Together they provide systems capable of delivering a maximum HSPF (Heating Seasonal Performance Factor) of 9.10 in the heating mode or a maximum standard S.E.E.R. (Seasonal Energy Efficiency Ratio) of 14.00 in the cooling mode.

The following additional features, plus its energy-saving characteristics, make the RPNE- Heat Pump outdoor unit an excellent choice for new construction or upgrading your present system.

- Attractive, louvered wrap around jacket protects coil from weather extremes and yard hazards. Top grille is steel reinforced for extra strength. Cabinet is powder painted for all weather protection.
- Four sided outdoor coil design allows compressor operation with access panel removed.
- Air is discharged upward away from bushes and shrubs. The discharge pattern of the top grille provides minimum air restriction, resulting in quiet fan operation.
- Combination Grille/Motor Mount secures the fan motor to the underside of the discharge grille.
- All controls are accessible by removing one service panel. Removable top grille provides access to the outdoor fan motor and outdoor coil.
- Compressor compartment offers additional protection from the elements and reduces operating noise.
- Single speed, 8-pole fan motor is designed for quieter, energy-saving operation.
- Non-cycling reversing valve and demand defrost.
- All models meet or exceed a 1000-hour salt spray test per ASTM B117 Standard Practice for Operating Salt Spray Testing Apparatus.

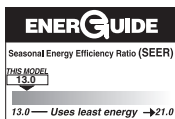



All controls and compressor are accessible for servicing by removal of the service panel.

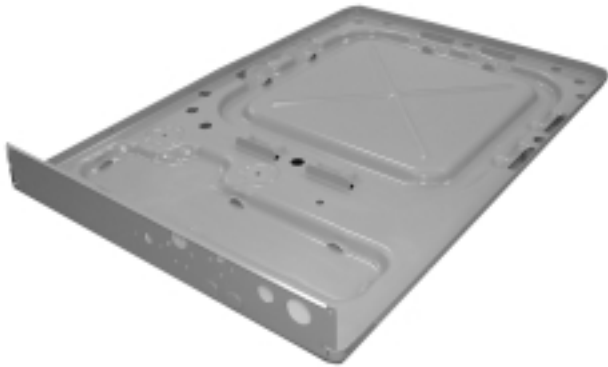

Drawn Painted Base Pan.

Engineering Features

RPNE- Series Heat Pump Outdoor Unit

1. **Scroll compressor** is hermetically sealed and incorporates internal high temperature motor overload protection, and durable insulation on the motor windings. It is externally mounted on rubber grommets to reduce vibration and noise.
2. **Copper Tube/Aluminum Fin Coils**—Both indoor and outdoor coils.
3. **Strong, Attractive Cabinet**—Constructed of powder painted steel. Louvered design protects the coil from damage.
4. **Internal Check Valve**—Provides for more quiet refrigerant metering.
5. **Enhanced Compressor Protection**—Features an **enhanced defrost control, auto-reset high pressure control, and auto-reset low pressure control** to provide compressor protection under abnormally high head pressure conditions (outdoor fan failure, restriction, dirty coil, etc.) or abnormally low suction pressure conditions (restrictions, TXV failure, loss of charge, indoor blower failure, etc.) while eliminating nuisance tripping sometimes experienced with conventional control systems.
6. **Drawn Painted Base Pan**—For extra corrosion resistance and sound reduction.
7. **Demand Defrost Control**—Provides complete defrost when defrost is required.
8. **Non-Cycling Reversing Valve**—Eliminates discharge noises on each heating cycle.
9. **Hot Gas Muffler**—Reduces noise in heating cycle.
10. **Bi-Directional Filter Drier**—Standard on all models.
11. **Service valves** are standard on all models.
12. **Refrigerant Metering**—TX valves accurately meter refrigerant into indoor and outdoor coils.
13. The **RPNE** has a 10 year limited compressor warranty.
14. All refrigerant connections are on the exterior of the unit, located close to the ground for neat appearing installations.
15. Coil design permits compressor operation with the access panel removed.
16. Control box is fully accessible in the upper part of the cabinet, just under the access panel.
17. Power and control wiring are kept separate.
18. Every unit is factory charged and tested.

Model Number Identification

<u>R</u>	<u>P</u>	<u>N</u>	<u>E</u>	<u>—</u>	<u>018</u>	<u>J</u>	<u>A</u>	<u>Z</u>
RHEEM	REMOTE HEAT PUMP	HIGH EFFICIENCY (STANDARD)	DESIGN SERIES		COOLING CAPACITY	ELECTRICAL DESIGNATION	VARIATIONS A-SERIES = FULL-FEATURED	COOLING CONNECTION FITTING Z = SWEAT W/SCROLL
					018 = 18,000 BTU/HR [5.28 kW] 024 = 24,000 BTU/HR [7.03 kW] 030 = 30,000 BTU/HR [8.79 kW] 036 = 36,000 BTU/HR [10.55 kW] 042 = 42,000 BTU/HR [12.31 kW] 048 = 48,000 BTU/HR [14.07 kW] 060 = 60,000 BTU/HR [17.58 kW]	J = 208/230V-1-60 C = 208/230V-3-60 D = 460V-3-60 Y = 575V-3-60 (4&5 TON ONLY)		

[] Designates Metric Conversions

Accessories

- **Low Ambient Control**—Allows low temperature operation in the cooling cycle down to 0°F [-17.8°C] outdoor temperature. It is recommended that this control be installed in units to be operated for cooling at outdoor ambient temperatures under 65°F [18°C]. (Model No. RXPZ-C01)
- **Outdoor Thermostats**—
 RXPT-A01—One outdoor thermostat in box.
 RXPT-A02—One outdoor thermostat for mounting in box for use with RXPT-A01 or A03.
 RXPT-A03—One outdoor thermostat with emergency Heat Relay wired and mounted in box.
 RXPT-A04—Two outdoor thermostats with emergency Heat Relay wired and mounted in box.
- **Compressor Crankcase Heater**—Available through PROSTOCK®.
- **Heat Pump Monitor**—Indicates inefficient operation or malfunction of heat pump. (Model No. RXPM-B01)
- **Thermostats**
 - **Compressor Time Delay Control**—Compressor will remain off for five minutes after power or thermostat interruption, allowing system pressures to equalize. Starting during high pressure conditions can result in shortened compressor life. (Model No. RXMD-B01)
 - **Blower Time Delay Control**—RXMD-C04—Time Delay Accessory is not required if the outdoor unit is matched with a Rheem furnace or air handler, or if the furnace or air handler used has a blower off time delay built in.
 - **Fossil Fuel Kits**—RXPF-01
 RXPF-02
 - **Enhanced Compressor Protection Kit (R-22)**—RXPG-A01. This kit includes an enhanced defrost control, auto-reset high pressure control (HPC), and auto-reset low pressure control (LPC). This kit provides compressor protection under abnormally high head pressure conditions (outdoor fan failure, restriction, dirty coil, etc.) or abnormally low suction pressure conditions (restriction, TEV failure, loss of charge, indoor blower failure, etc.) while eliminating nuisance tripping sometimes experienced with conventional control systems.
 - **Hard Start Components**—Offer additional starting torque to cover a wide range of voltage and pressure variations. Available through PROSTOCK®



300-Series *
Deluxe Programmable

200-Series *
Programmable

100-Series *
Non-Programmable

400-Series *
Special Applications/Programmable

[] Designates Metric Conversions

Brand	Unique Model Number Prefix	Descriptor (3 Characters)	Series (3 Characters)	System (2 Characters)	Type (2 Characters)
RHC	-	TST	101	GE	MS
RHC=Rheem		TST=Thermostat	100=Non-Programmable 200=Programmable 300=Deluxe Programmable 400=Special Applications/ Programmable	GE=Gas/Oil/Electric HP=Heat Pump MD=Modulating Furnace DF=Dual Fuel UN=Universal AC/HP/GE	SS=Single-Stage MS=Multi-Stage

* Photos are representative. Actual models may vary.

For detailed thermostat match-up information, see specification sheet form number T11-001.

Rheem Heat Pump System

For all season home comfort, performance and energy conservation, choose a Rheem RPNE- Series Heat Pump and a RHSA, RHLA, or RHKA Series Air Handler.

More than a reverse cycle air conditioner, it's a specially designed combination Winter/Summer comfort system using a single indoor coil for heating and cooling.

To choose an Air Handler designed for use with the RPNE- Heat Pump, refer to the Performance Data Tables and/or the air handler specification sheet.

SCROLL® COMPRESSOR

The scroll compressor is the key to efficiency for this Rheem model. It's the latest in high-efficiency compressor technology. The advanced scroll compressor offers low noise and vibration characteristics and features tolerance to liquid refrigerant and system contamination. The Scroll also has low start torque, eliminating start problems in the field. And its unique design enables the RPNE- heat pump to perform efficiently, quietly and reliably.



Performance Data ARI Standard Conditions—Single Phase (Scroll Compressor)

Note: Only these combinations of indoor/outdoor units are approved and any other combinations should not be used.

Model Numbers		ARI Cooling Performance							ARI Heating Performance (70°F [21°C] Indoor)				
		80°F [26.5°C] DB/67°F [19.5°C] WB Indoor Air 95°F [35°C] DB Outdoor Air							Outdoor Air 47°F [8.5°C] DB/ 43°F [6°C] WB DOE High Temp.		Outdoor Air 17°F [-8.5°C] DB/ 15°F [-9.5°C] WB DOE Low Temp.		DOE Region IV HSPF
Outdoor Unit RPNE-	Indoor Coil and/or Air Handler	Total Capacity BTU/H [kW]	Net Sens. BTU/H [kW]	Net Latent BTU/H [kW]	EER	SEER	Snd. Rate dB	Indoor CFM [L/s]	BTU/H [kW]	COP	BTU/H [kW]	COP	
Rev. 3/25/2008													
018JAZ	RHSA-HM1817 (RCSA-H*2417A*) ①	18,400 [5.4]	13,350 [3.9]	5,050 [1.5]	11.70	13.00	72	650 [307]	17,300 [5.1]	3.24	11,000 [3.2]	2.46	8.50
	RCFA-H*2414A*+RXMD-C04	18,500 [5.4]	13,450 [3.9]	5,050 [1.5]	11.15	13.00	72	650 [307]	17,400 [5.1]	3.34	11,100 [3.3]	2.42	8.35
	RCFA-H*2417A* (RGFD-06?MCK?)	18,700 [5.5]	13,550 [4.0]	5,150 [1.5]	12.30	14.00	72	600 [283]	16,900 [5.0]	3.60	10,600 [3.1]	2.60	8.90
	RCFA-H*2417A* (RGFD-07?MCK?)	18,700 [5.5]	13,550 [4.0]	5,150 [1.5]	12.35	14.00	72	600 [283]	16,900 [5.0]	3.60	10,600 [3.1]	2.60	9.00
	RCFA-H*2417A* (RGGD-06?MCK?)	18,700 [5.5]	13,600 [4.0]	5,100 [1.5]	12.50	14.00	72	600 [283]	16,900 [5.0]	3.64	10,600 [3.1]	2.62	9.00
	RCFA-H*2417A* (RGGD-07?MCK?)	19,000 [5.6]	13,750 [4.0]	5,250 [1.5]	12.60	14.00	72	625 [295]	16,900 [5.0]	3.62	10,600 [3.1]	2.62	9.00
	RCFA-H*2417A* (RGJD-06?MCK?)	18,700 [5.5]	13,600 [4.0]	5,100 [1.5]	12.50	14.00	72	600 [283]	16,900 [5.0]	3.62	10,600 [3.1]	2.62	9.00
	RCFA-H*2417A* (RGJD-07?MCK?)	19,000 [5.6]	13,750 [4.0]	5,250 [1.5]	12.60	14.00	72	625 [295]	16,900 [5.0]	3.62	10,600 [3.1]	2.62	9.00
	RCFA-H*2417A* (RGLR-07?AMK?)	18,800 [5.5]	13,600 [4.0]	5,200 [1.5]	12.50	14.00	72	600 [283]	16,900 [5.0]	3.64	10,600 [3.1]	2.62	9.00
	RCFA-H*2417A* (RGPR-05?BMK?)	18,700 [5.5]	13,550 [4.0]	5,150 [1.5]	12.25	14.00	72	600 [283]	17,000 [5.0]	3.58	10,600 [3.1]	2.58	8.90
	RCFA-H*2417A* (RGPR-07?AMK?)	18,700 [5.5]	13,600 [4.0]	5,100 [1.5]	12.45	14.00	72	600 [283]	16,900 [5.0]	3.62	10,600 [3.1]	2.62	9.00
	RCFA-H*2417A*+RXMD-C04	18,500 [5.4]	13,450 [3.9]	5,050 [1.5]	11.15	13.00	72	650 [307]	17,400 [5.1]	3.34	11,100 [3.3]	2.42	8.35
	RBHP-17 (RCHJ-24A1)	18,000 [5.3]	13,300 [3.9]	4,700 [1.4]	12.15	14.00	72	600 [283]	17,000 [5.0]	3.90	10,200 [3.0]	2.60	8.20
	RCHJ-24A1 (RGFD-06?MCK?)	18,000 [5.3]	13,350 [3.9]	4,650 [1.4]	12.20	13.00	72	600 [283]	17,000 [5.0]	3.92	10,200 [3.0]	2.58	8.20
	RCHJ-24A1 (RGFD-07?MCK?)	18,000 [5.3]	13,350 [3.9]	4,650 [1.4]	12.25	13.00	72	600 [283]	17,000 [5.0]	3.92	10,200 [3.0]	2.58	8.20
	RCHJ-24A1 (RGGD-06?MCK?)	18,100 [5.3]	13,350 [3.9]	4,750 [1.4]	12.40	13.00	72	600 [283]	17,000 [5.0]	3.92	10,200 [3.0]	2.58	8.20
	RCHJ-24A1 (RGGD-07?MCK?)	18,000 [5.3]	13,350 [3.9]	4,650 [1.4]	12.30	13.00	72	625 [295]	17,000 [5.0]	3.92	10,200 [3.0]	2.58	8.20
	RCHJ-24A1 (RGJD-06?MCK?)	18,100 [5.3]	13,350 [3.9]	4,750 [1.4]	12.40	13.00	72	600 [283]	17,000 [5.0]	3.92	10,200 [3.0]	2.58	8.20
	RCHJ-24A1 (RGJD-07?MCK?)	18,000 [5.3]	13,350 [3.9]	4,650 [1.4]	12.30	13.00	72	625 [295]	17,000 [5.0]	3.92	10,200 [3.0]	2.58	8.20
	RCHJ-24A1 (RGLR-07?AMK?)	18,100 [5.3]	13,400 [3.9]	4,700 [1.4]	12.40	13.00	72	600 [283]	17,000 [5.0]	3.92	10,200 [3.0]	2.58	8.20
	RCHJ-24A1 (RGPR-05?BMK?)	18,000 [5.3]	13,300 [3.9]	4,700 [1.4]	12.15	13.00	72	600 [283]	17,000 [5.0]	3.92	10,200 [3.0]	2.58	8.20
	RCHJ-24A1 (RGPR-07?AMK?)	18,100 [5.3]	13,350 [3.9]	4,750 [1.4]	12.35	13.00	72	600 [283]	17,000 [5.0]	3.92	10,200 [3.0]	2.58	8.20
	17AHLA24HM (RCSA-H*2417A*)	18,700 [5.5]	13,550 [4.0]	5,150 [1.5]	12.35	14.00	72	600 [283]	16,900 [5.0]	3.62	10,600 [3.1]	2.62	9.00
17AHS18HM (RCSA-H*2417A*)	18,400 [5.4]	13,350 [3.9]	5,050 [1.5]	11.70	13.00	72	650 [307]	17,300 [5.1]	3.24	11,000 [3.2]	2.46	8.50	
RHKA-HM2417 (RCSA-H*2417A*)	19,000 [5.6]	13,800 [4.0]	5,200 [1.5]	12.60	14.00	72	650 [307]	16,900 [5.0]	3.62	10,600 [3.1]	2.62	9.00	
RHLA-HM2417 (RCSA-H*2417A*)	18,700 [5.5]	13,550 [4.0]	5,150 [1.5]	12.35	14.00	72	600 [283]	16,900 [5.0]	3.62	10,600 [3.1]	2.62	9.00	
024JAZ	RHSA-HM2417 (RCSA-H*2417A*) ①	23,600 [6.9]	17,200 [5.0]	6,400 [1.9]	11.40	13.00	73	825 [389]	23,000 [6.7]	3.54	14,400 [4.2]	2.40	8.50
	RCFA-H*2414A*	23,400 [6.9]	16,850 [4.9]	6,550 [1.9]	11.35	13.00	73	700 [330]	22,600 [6.6]	3.36	14,400 [4.2]	2.30	8.30
	RCFA-H*2417A*	23,400 [6.9]	16,850 [4.9]	6,550 [1.9]	11.35	13.00	73	700 [330]	22,600 [6.6]	3.36	14,400 [4.2]	2.30	8.30

① Highest sales volume tested combination required by DOE test procedures.

[] Designates Metric Conversions

Performance Data ARI Standard Conditions—Single Phase (Scroll Compressor)

Note: Only these combinations of indoor/outdoor units are approved and any other combinations should not be used.

Model Numbers		ARI Cooling Performance							ARI Heating Performance (70°F [21°C] Indoor)				
		80°F [26.5°C] DB/67°F [19.5°C] WB Indoor Air 95°F [35°C] DB Outdoor Air							Outdoor Air 47°F [8.5°C] DB/ 43°F [6°C] WB DOE High Temp.		Outdoor Air 17°F [-8.5°C] DB/ 15°F [-9.5°C] WB DOE Low Temp.		DOE Region IV HSPF
Outdoor Unit RPNE-	Indoor Coil and/or Air Handler	Total Capacity BTU/H [kW]	Net Sens. BTU/H [kW]	Net Latent BTU/H [kW]	EER	SEER	Snd. Rate dB	Indoor CFM [L/s]	BTU/H [kW]	COP	BTU/H [kW]	COP	
Rev. 3/25/2008													
024JAZ	RCFA-H*2417A* (RGFD-06?MCK?)	23,800 [7.0]	17,300 [5.1]	6,500 [1.9]	11.80	13.50	73	800 [378]	22,800 [6.7]	3.64	14,200 [4.2]	2.48	8.60
	RCFA-H*2417A* (RGFD-07?MCK?)	23,800 [7.0]	17,350 [5.1]	6,450 [1.9]	11.90	13.50	73	800 [378]	22,800 [6.7]	3.64	14,100 [4.1]	2.50	8.65
	RCFA-H*2417A* (RGGD-06?MCK?)	23,800 [7.0]	17,400 [5.1]	6,400 [1.9]	12.10	14.00	73	800 [378]	22,600 [6.6]	3.68	14,100 [4.1]	2.52	8.75
	RCFA-H*2417A* (RGGD-07?MCK?)	23,800 [7.0]	17,350 [5.1]	6,450 [1.9]	12.00	13.50	73	800 [378]	22,600 [6.6]	3.66	14,100 [4.1]	2.50	8.70
	RCFA-H*2417A* (RGJD-06?MCK?)	23,800 [7.0]	17,400 [5.1]	6,400 [1.9]	12.10	14.00	73	800 [378]	22,600 [6.6]	3.68	14,100 [4.1]	2.52	8.75
	RCFA-H*2417A* (RGJD-07?MCK?)	23,800 [7.0]	17,350 [5.1]	6,450 [1.9]	12.00	13.50	73	800 [378]	22,600 [6.6]	3.66	14,100 [4.1]	2.50	8.70
	RCFA-H*2417A* (RGLR-07?AMK?)	24,000 [7.0]	17,450 [5.1]	6,550 [1.9]	12.25	14.00	73	800 [378]	22,600 [6.6]	3.70	14,000 [4.1]	2.54	8.75
	RCFA-H*2417A* (RGPR-05?BMK?)	23,600 [6.9]	17,150 [5.0]	6,450 [1.9]	11.80	13.50	73	775 [366]	22,800 [6.7]	3.64	14,100 [4.1]	2.50	8.65
	RCFA-H*2417A* (RGPR-07?AMK?)	24,000 [7.0]	17,450 [5.1]	6,550 [1.9]	12.15	14.00	73	800 [378]	22,600 [6.6]	3.70	14,000 [4.1]	2.52	8.75
	RBHP-17 (RCHJ-24A1)	23,600 [6.9]	17,300 [5.1]	6,300 [1.8]	11.60	13.00	73	800 [378]	23,000 [6.7]	3.54	15,000 [4.4]	2.58	8.20
	RCHJ-24A1 (RGFD-07?MCK?)	23,600 [6.9]	17,300 [5.1]	6,300 [1.8]	11.65	13.00	73	800 [378]	23,000 [6.7]	3.56	15,000 [4.4]	2.58	8.20
	RCHJ-24A1 (RGGD-06?MCK?)	23,600 [6.9]	17,350 [5.1]	6,250 [1.8]	11.80	13.00	73	800 [378]	23,000 [6.7]	3.56	15,000 [4.4]	2.58	8.20
	RCHJ-24A1 (RGGD-07?MCK?)	23,600 [6.9]	17,350 [5.1]	6,250 [1.8]	11.70	13.00	73	800 [378]	23,000 [6.7]	3.56	15,000 [4.4]	2.58	8.20
	RCHJ-24A1 (RGJD-06?MCK?)	23,600 [6.9]	17,350 [5.1]	6,250 [1.8]	11.80	13.00	73	800 [378]	23,000 [6.7]	3.56	15,000 [4.4]	2.58	8.20
	RCHJ-24A1 (RGJD-07?MCK?)	23,600 [6.9]	17,350 [5.1]	6,250 [1.8]	11.70	13.00	73	800 [378]	23,000 [6.7]	3.56	15,000 [4.4]	2.58	8.20
	RCHJ-24A1 (RGLR-07?AMK?)	23,600 [6.9]	17,400 [5.1]	6,200 [1.8]	11.95	13.00	73	800 [378]	23,000 [6.7]	3.56	15,000 [4.4]	2.58	8.20
	RCHJ-24A1 (RGPR-05?BMK?)	23,600 [6.9]	17,300 [5.1]	6,300 [1.8]	11.65	13.00	73	775 [366]	23,000 [6.7]	3.56	15,000 [4.4]	2.58	8.20
	RCHJ-24A1 (RGPR-07?AMK?)	23,600 [6.9]	17,400 [5.1]	6,200 [1.8]	11.85	13.00	73	800 [378]	23,000 [6.7]	3.56	15,000 [4.4]	2.58	8.20
	17AHLA24HM (RCSA-H*2417A*)	24,000 [7.0]	17,450 [5.1]	6,550 [1.9]	12.50	14.00	73	775 [366]	22,400 [6.6]	3.76	13,900 [4.1]	2.56	9.10
	17AHS24HM (RCSA-H*2417A*)	23,600 [6.9]	17,200 [5.0]	6,400 [1.9]	11.40	13.00	73	825 [389]	23,000 [6.7]	3.54	14,400 [4.2]	2.40	8.50
RHKA-HM2417 (RCSA-H*2417A*)	23,800 [7.0]	17,400 [5.1]	6,400 [1.9]	12.10	14.00	73	850 [401]	22,600 [6.6]	3.68	14,000 [4.1]	2.52	8.70	
RHLA-HM2417 (RCSA-H*2417A*)	24,000 [7.0]	17,450 [5.1]	6,550 [1.9]	12.50	14.00	73	775 [366]	22,400 [6.6]	3.76	13,900 [4.1]	2.56	9.10	
030JAZ	RHSA-HM3017 (RCSA-H*3617A*) ①	30,200 [8.8]	21,500 [6.3]	8,700 [2.5]	11.45	13.00	73	1,050 [495]	33,400 [9.8]	3.48	21,000 [6.2]	2.48	8.50
	RCFA-H*3617A*	30,000 [8.8]	21,300 [6.2]	8,700 [2.5]	11.10	13.00	73	1,050 [495]	33,600 [9.8]	3.42	21,200 [6.2]	2.42	8.35
	RCFA-H*3617A* (RGLR-07?AMK?)	30,400 [8.9]	21,650 [6.3]	8,750 [2.6]	11.95	13.50	73	1,025 [484]	33,000 [9.7]	3.56	20,600 [6.0]	2.52	8.75
	RCFA-H*3617A* (RGPR-07?AMK?)	30,200 [8.8]	21,450 [6.3]	8,750 [2.6]	11.80	13.50	73	1,000 [472]	33,200 [9.7]	3.56	20,800 [6.1]	2.52	8.75
	RCFA-H*3621A*	30,000 [8.8]	21,300 [6.2]	8,700 [2.5]	11.10	13.00	73	1,050 [495]	33,600 [9.8]	3.42	21,200 [6.2]	2.42	8.35
	RCFA-H*3621A* (RGLR-07?AMK?)	30,400 [8.9]	21,650 [6.3]	8,750 [2.6]	11.95	13.50	73	1,025 [484]	33,000 [9.7]	3.56	20,600 [6.0]	2.52	8.65
	RCFA-H*3621A* (RGLR-07?BRQ?)	30,200 [8.8]	21,250 [6.2]	8,950 [2.6]	12.10	13.50	73	1,000 [472]	33,000 [9.7]	3.60	20,600 [6.0]	2.54	8.75

① Highest sales volume tested combination required by DOE test procedures.

[] Designates Metric Conversions

Performance Data ARI Standard Conditions—Single Phase (Scroll Compressor)

Note: Only these combinations of indoor/outdoor units are approved and any other combinations should not be used.

Model Numbers		ARI Cooling Performance							ARI Heating Performance (70°F [21°C] Indoor)				
		80°F [26.5°C] DB/67°F [19.5°C] WB Indoor Air 95°F [35°C] DB Outdoor Air							Outdoor Air 47°F [8.5°C] DB/ 43°F [6°C] WB DOE High Temp.		Outdoor Air 17°F [-8.5°C] DB/ 15°F [-9.5°C] WB DOE Low Temp.		DOE Region IV HSPF
Outdoor Unit RPNE-	Indoor Coil and/or Air Handler	Total Capacity BTU/H [kW]	Net Sens. BTU/H [kW]	Net Latent BTU/H [kW]	EER	SEER	Snd. Rate dB	Indoor CFM [L/s]	BTU/H [kW]	COP	BTU/H [kW]	COP	
Rev. 3/25/2008													
030JAZ	RCFA-H*3621A* (RGPR-07?BRQ?)	30,400 [8.9]	21,600 [6.3]	8,800 [2.6]	12.20	14.00	73	1,000 [472]	33,000 [9.7]	3.62	20,600 [6.0]	2.56	8.75
	RBHP-21 (RCHJ-36A1)	29,800 [8.7]	20,750 [6.1]	9,050 [2.7]	12.00	14.00	73	1,000 [472]	32,200 [9.4]	3.80	20,000 [5.9]	2.64	8.20
	RCHJ-36A1 (RGFD-06?MCK?)	29,400 [8.6]	20,400 [6.0]	9,000 [2.6]	11.25	13.00	73	1,000 [472]	32,200 [9.4]	3.78	20,000 [5.9]	2.64	8.20
	RCHJ-36A1 (RGFD-07?MCK?)	29,400 [8.6]	20,500 [6.0]	8,900 [2.6]	11.45	13.00	73	1,000 [472]	32,200 [9.4]	3.78	20,000 [5.9]	2.64	8.20
	RCHJ-36A1 (RGGD-06?MCK?)	29,600 [8.7]	20,550 [6.0]	9,050 [2.7]	11.55	13.00	73	1,000 [472]	32,200 [9.4]	3.78	20,000 [5.9]	2.64	8.20
	RCHJ-36A1 (RGGD-07?MCK?)	29,600 [8.7]	20,650 [6.1]	8,950 [2.6]	11.55	13.00	73	1,025 [484]	33,000 [9.7]	3.54	20,800 [6.1]	2.48	8.20
	RCHJ-36A1 (RGJD-06?MCK?)	29,600 [8.7]	20,550 [6.0]	9,050 [2.7]	11.55	13.00	73	1,000 [472]	32,200 [9.4]	3.78	20,000 [5.9]	2.64	8.20
	RCHJ-36A1 (RGJD-07?MCK?)	29,600 [8.7]	20,650 [6.1]	8,950 [2.6]	11.55	13.00	73	1,025 [484]	33,000 [9.7]	3.54	20,800 [6.1]	2.48	8.20
	RCHJ-36A1 (RGLR-07?AMK?)	29,800 [8.7]	20,750 [6.1]	9,050 [2.7]	11.85	13.00	73	1,025 [484]	32,800 [9.6]	3.58	20,600 [6.0]	2.50	8.20
	RCHJ-36A1 (RGPR-05?BMK?)	29,400 [8.6]	20,500 [6.0]	8,900 [2.6]	11.45	13.00	73	1,000 [472]	32,200 [9.4]	3.78	20,000 [5.9]	2.64	8.20
	RCHJ-36A1 (RGPR-07?AMK?)	29,600 [8.7]	20,600 [6.0]	9,000 [2.6]	11.70	13.00	73	1,000 [472]	32,200 [9.4]	3.78	20,000 [5.9]	2.64	8.20
	RCHJ-36A1 (RGPR-07?BRQ?)	29,800 [8.7]	20,750 [6.1]	9,050 [2.7]	12.05	13.00	73	1,000 [472]	32,200 [9.4]	3.78	20,000 [5.9]	2.64	8.20
	17AHLA36HM (RCSA-H*3617A*)	30,400 [8.9]	21,600 [6.3]	8,800 [2.6]	12.20	14.00	73	1,000 [472]	33,000 [9.7]	3.62	20,600 [6.0]	2.56	8.70
	17AHS30HM (RCSA-H*3617A*)	30,200 [8.8]	21,500 [6.3]	8,700 [2.5]	11.45	13.00	73	1,050 [495]	33,400 [9.8]	3.48	21,000 [6.2]	2.48	8.50
	RHKA-HM3617 (RCSA-H*3617A*)	30,600 [9.0]	21,750 [6.4]	8,850 [2.6]	12.20	14.00	73	1,025 [484]	33,000 [9.7]	3.60	20,600 [6.0]	2.56	8.70
RHLA-HM3617 (RCSA-H*3617A*)	30,400 [8.9]	21,600 [6.3]	8,800 [2.6]	12.20	14.00	73	1,000 [472]	33,000 [9.7]	3.62	20,600 [6.0]	2.56	8.70	
036CAZ	RCFA-H*3617A*	35,200 [10.3]	24,750 [7.3]	10,450 [3.1]	11.10	13.00	74	1,175 [554]	37,600 [11.0]	3.50	24,000 [7.0]	2.46	8.40
	RCFA-H*3621A*	35,400 [10.4]	24,950 [7.3]	10,450 [3.1]	11.10	13.00	74	1,175 [554]	38,000 [11.1]	3.50	24,200 [7.1]	2.46	8.40
	RCFA-H*3621A* (RGFD-09?ZCM?)	35,800 [10.5]	25,250 [7.4]	10,550 [3.1]	11.70	13.50	74	1,150 [543]	37,400 [11.0]	3.62	23,800 [7.0]	2.54	8.80
	RCFA-H*3621A* (RGGD-09?ZCM?)	35,800 [10.5]	25,200 [7.4]	10,600 [3.1]	11.70	13.50	74	1,175 [554]	37,400 [11.0]	3.62	23,800 [7.0]	2.54	8.80
	RCFA-H*3621A* (RGGD-10?ZCM?)	35,800 [10.5]	25,250 [7.4]	10,550 [3.1]	11.75	13.50	74	1,175 [554]	37,400 [11.0]	3.62	23,800 [7.0]	2.54	8.80
	RCFA-H*3621A* (RGJD-09?ZCM?)	35,800 [10.5]	25,200 [7.4]	10,600 [3.1]	11.70	13.50	74	1,175 [554]	37,400 [11.0]	3.62	23,800 [7.0]	2.54	8.80
	RCFA-H*3621A* (RGJD-10?ZCM?)	35,800 [10.5]	25,250 [7.4]	10,550 [3.1]	11.75	13.50	74	1,175 [554]	37,400 [11.0]	3.62	23,800 [7.0]	2.54	8.80
	RCFA-H*3621A* (RGLR-07?BRQ?)	36,800 [10.8]	26,900 [7.9]	9,900 [2.9]	11.90	13.50	74	1,225 [578]	37,400 [11.0]	3.62	23,800 [7.0]	2.54	8.85
	RCFA-H*3621A* (RGLR-10?BRM?)	35,800 [10.5]	25,300 [7.4]	10,500 [3.1]	11.85	13.50	74	1,200 [566]	37,200 [10.9]	3.64	23,600 [6.9]	2.54	8.85
	RCFA-H*3621A* (RGPR-07?BRQ?)	36,000 [10.5]	25,300 [7.4]	10,700 [3.1]	11.85	13.50	74	1,200 [566]	37,200 [10.9]	3.64	23,600 [6.9]	2.56	8.85
	RCFA-H*3621A* (RGPR-10?BRM?)	36,000 [10.5]	25,400 [7.4]	10,600 [3.1]	11.70	13.50	74	1,225 [578]	37,400 [11.0]	3.60	23,800 [7.0]	2.52	8.75
	RBHP-21 (RCHJ-36A1)	34,600 [10.1]	24,050 [7.0]	10,550 [3.1]	11.80	13.50	74	1,225 [578]	37,200 [10.9]	3.68	23,600 [6.9]	2.60	8.20
	RCHJ-36A1 (RGFD-09?ZCM?)	34,400 [10.1]	23,850 [7.0]	10,550 [3.1]	11.60	13.00	74	1,150 [543]	37,200 [10.9]	3.66	23,800 [7.0]	2.60	8.20

① Highest sales volume tested combination required by DOE test procedures.

[] Designates Metric Conversions

Performance Data ARI Standard Conditions—Single Phase (Scroll Compressor)

Note: Only these combinations of indoor/outdoor units are approved and any other combinations should not be used.

Model Numbers		ARI Cooling Performance							ARI Heating Performance (70°F [21°C] Indoor)				
		80°F [26.5°C] DB/67°F [19.5°C] WB Indoor Air 95°F [35°C] DB Outdoor Air							Outdoor Air 47°F [8.5°C] DB/ 43°F [6°C] WB DOE High Temp.		Outdoor Air 17°F [-8.5°C] DB/ 15°F [-9.5°C] WB DOE Low Temp.		DOE Region IV HSPF
Outdoor Unit RPNE-	Indoor Coil and/or Air Handler	Total Capacity BTU/H [kW]	Net Sens. BTU/H [kW]	Net Latent BTU/H [kW]	EER	SEER	Snd. Rate dB	Indoor CFM [L/s]	BTU/H [kW]	COP	BTU/H [kW]	COP	
		Rev. 3/25/2008											
036CAZ	RCHJ-36A1 (RGFD-10?ZCM?)	34,400 [10.1]	24,000 [7.0]	10,400 [3.0]	11.50	13.00	74	1,175 [554]	37,200 [10.9]	3.66	23,800 [7.0]	2.60	8.20
	RCHJ-36A1 (RGFD-12?RCM?)	34,600 [10.1]	24,050 [7.0]	10,550 [3.1]	11.60	13.00	74	1,225 [578]	37,200 [10.9]	3.66	23,800 [7.0]	2.60	8.20
	RCHJ-36A1 (RGGD-09?ZCM?)	34,600 [10.1]	24,050 [7.0]	10,550 [3.1]	11.65	13.00	74	1,175 [554]	36,400 [10.7]	3.90	23,000 [6.7]	2.74	8.20
	RCHJ-36A1 (RGGD-10?ZCM?)	34,600 [10.1]	24,050 [7.0]	10,550 [3.1]	11.65	13.00	74	1,175 [554]	36,400 [10.7]	3.90	23,000 [6.7]	2.74	8.20
	RCHJ-36A1 (RGGD-12?RCM?)	34,600 [10.1]	24,100 [7.1]	10,500 [3.1]	11.75	13.00	74	1,225 [578]	36,400 [10.7]	3.90	23,000 [6.7]	2.74	8.20
	RCHJ-36A1 (RGJD-09?ZCM?)	34,600 [10.1]	24,050 [7.0]	10,550 [3.1]	11.65	13.00	74	1,175 [554]	36,400 [10.7]	3.88	23,000 [6.7]	2.74	8.20
	RCHJ-36A1 (RGJD-10?ZCM?)	34,600 [10.1]	24,050 [7.0]	10,550 [3.1]	11.65	13.00	74	1,175 [554]	36,400 [10.7]	3.88	23,000 [6.7]	2.74	8.20
	RCHJ-36A1 (RGJD-12?RCM?)	34,600 [10.1]	24,100 [7.1]	10,500 [3.1]	11.75	13.00	74	1,225 [578]	36,400 [10.7]	3.88	23,000 [6.7]	2.74	8.20
	RCHJ-36A1 (RGLR-07?AMK?)	34,400 [10.1]	23,900 [7.0]	10,500 [3.1]	11.35	13.00	74	1,200 [566]	36,400 [10.7]	3.88	23,000 [6.7]	2.74	8.20
	RCHJ-36A1 (RGLR-10?BRM?)	34,600 [10.1]	24,100 [7.1]	10,500 [3.1]	11.80	13.00	74	1,200 [566]	36,400 [10.7]	3.88	23,000 [6.7]	2.74	8.20
	RCHJ-36A1 (RGLR-12?ARM?)	34,800 [10.2]	24,150 [7.1]	10,650 [3.1]	11.85	13.00	74	1,225 [578]	36,400 [10.7]	3.88	23,000 [6.7]	2.74	8.20
	RCHJ-36A1 (RGPR-07?AMK?)	34,400 [10.1]	23,900 [7.0]	10,500 [3.1]	11.35	13.00	74	1,200 [566]	37,200 [10.9]	3.66	23,800 [7.0]	2.58	8.20
	RCHJ-36A1 (RGPR-07?BRQ?)	34,600 [10.1]	24,150 [7.1]	10,450 [3.1]	11.80	13.00	74	1,200 [566]	37,200 [10.9]	3.66	23,800 [7.0]	2.58	8.20
	RCHJ-36A1 (RGPR-10?BRM?)	34,600 [10.1]	24,050 [7.0]	10,550 [3.1]	11.65	13.00	74	1,225 [578]	37,200 [10.9]	3.66	23,800 [7.0]	2.58	8.20
	RCHJ-36A1 (RGPR-12?ARM?)	34,800 [10.2]	24,250 [7.1]	10,550 [3.1]	11.80	13.00	74	1,250 [590]	37,200 [10.9]	3.68	23,600 [6.9]	2.60	8.20
	17AHLA36HM (RCSA-H*3617A*)	36,000 [10.5]	25,350 [7.4]	10,650 [3.1]	11.95	13.50	74	1,200 [566]	37,200 [10.9]	3.64	23,600 [6.9]	2.56	8.85
	17AHS36HM (RCSA-H*3617A*)	35,400 [10.4]	24,950 [7.3]	10,450 [3.1]	11.25	13.00	74	1,175 [554]	37,800 [11.1]	3.50	24,200 [7.1]	2.46	8.50
	RHKA-HM3617 (RCSA-H*3617A*)	36,000 [10.5]	25,450 [7.5]	10,550 [3.1]	11.80	13.50	74	1,225 [578]	37,400 [11.0]	3.62	23,800 [7.0]	2.54	8.80
	RHLA-HM3617 (RCSA-H*3617A*)	36,000 [10.5]	25,350 [7.4]	10,650 [3.1]	11.95	13.50	74	1,200 [566]	37,200 [10.9]	3.64	23,600 [6.9]	2.56	8.85
	RHSA-HM3617 (RCSA-H*3617A*)	35,400 [10.4]	24,950 [7.3]	10,450 [3.1]	11.25	13.00	74	1,175 [554]	37,800 [11.1]	3.50	24,200 [7.1]	2.46	8.50
RHSA-HM3621 (RCSA-H*3621A*)	35,400 [10.4]	24,950 [7.3]	10,450 [3.1]	11.25	13.00	74	1,175 [554]	37,800 [11.1]	3.50	24,200 [7.1]	2.46	8.50	
036DAZ	RCFA-H*3617A*	35,200 [10.3]	24,750 [7.3]	10,450 [3.1]	11.10	13.00	74	1,175 [554]	37,600 [11.0]	3.50	24,000 [7.0]	2.46	8.40
	RCFA-H*3621A*	35,400 [10.4]	24,950 [7.3]	10,450 [3.1]	11.10	13.00	74	1,175 [554]	38,000 [11.1]	3.50	24,200 [7.1]	2.46	8.40
	RCFA-H*3621A* (RGFD-09?ZCM?)	35,800 [10.5]	25,250 [7.4]	10,550 [3.1]	11.70	13.50	74	1,150 [543]	37,400 [11.0]	3.62	23,800 [7.0]	2.54	8.80
	RCFA-H*3621A* (RGGD-09?ZCM?)	35,800 [10.5]	25,200 [7.4]	10,600 [3.1]	11.70	13.50	74	1,175 [554]	37,400 [11.0]	3.62	23,800 [7.0]	2.54	8.80
	RCFA-H*3621A* (RGGD-10?ZCM?)	35,800 [10.5]	25,250 [7.4]	10,550 [3.1]	11.75	13.50	74	1,175 [554]	37,400 [11.0]	3.62	23,800 [7.0]	2.54	8.80
	RCFA-H*3621A* (RGJD-09?ZCM?)	35,800 [10.5]	25,200 [7.4]	10,600 [3.1]	11.70	13.50	74	1,175 [554]	37,400 [11.0]	3.62	23,800 [7.0]	2.54	8.80
	RCFA-H*3621A* (RGJD-10?ZCM?)	35,800 [10.5]	25,250 [7.4]	10,550 [3.1]	11.75	13.50	74	1,175 [554]	37,400 [11.0]	3.62	23,800 [7.0]	2.54	8.80
	RCFA-H*3621A* (RGLR-07?BRQ?)	36,800 [10.8]	26,900 [7.9]	9,900 [2.9]	11.90	13.50	74	1,225 [578]	37,400 [11.0]	3.62	23,800 [7.0]	2.54	8.85

① Highest sales volume tested combination required by DOE test procedures.

[] Designates Metric Conversions

Performance Data ARI Standard Conditions—Single Phase (Scroll Compressor)

Note: Only these combinations of indoor/outdoor units are approved and any other combinations should not be used.

Model Numbers		ARI Cooling Performance							ARI Heating Performance (70°F [21°C] Indoor)				
		80°F [26.5°C] DB/67°F [19.5°C] WB Indoor Air 95°F [35°C] DB Outdoor Air							Outdoor Air 47°F [8.5°C] DB/ 43°F [6°C] WB DOE High Temp.		Outdoor Air 17°F [-8.5°C] DB/ 15°F [-9.5°C] WB DOE Low Temp.		DOE Region IV HSPF
Outdoor Unit RPNE-	Indoor Coil and/or Air Handler	Total Capacity BTU/H [kW]	Net Sens. BTU/H [kW]	Net Latent BTU/H [kW]	EER	SEER	Snd. Rate dB	Indoor CFM [L/s]	BTU/H [kW]	COP	BTU/H [kW]	COP	
Rev. 3/25/2008													
036DAZ	RCFA-H*3621A* (RGLR-10?BRM?)	35,800 [10.5]	25,300 [7.4]	10,500 [3.1]	11.85	13.50	74	1,200 [566]	37,200 [10.9]	3.64	23,600 [6.9]	2.54	8.85
	RCFA-H*3621A* (RGPR-07?BRQ?)	36,000 [10.5]	25,300 [7.4]	10,700 [3.1]	11.85	13.50	74	1,200 [566]	37,200 [10.9]	3.64	23,600 [6.9]	2.56	8.85
	RCFA-H*3621A* (RGPR-10?BRM?)	36,000 [10.5]	25,400 [7.4]	10,600 [3.1]	11.70	13.50	74	1,225 [578]	37,400 [11.0]	3.60	23,800 [7.0]	2.52	8.75
	RBHP-21 (RCHJ-36A1)	34,600 [10.1]	24,050 [7.0]	10,550 [3.1]	11.80	13.50	74	1,225 [578]	37,200 [10.9]	3.68	23,600 [6.9]	2.60	8.20
	RCHJ-36A1 (RGFD-09?ZCM?)	34,400 [10.1]	23,850 [7.0]	10,550 [3.1]	11.60	13.00	74	1,150 [543]	37,200 [10.9]	3.66	23,800 [7.0]	2.60	8.20
	RCHJ-36A1 (RGFD-10?ZCM?)	34,400 [10.1]	24,000 [7.0]	10,400 [3.0]	11.50	13.00	74	1,175 [554]	37,200 [10.9]	3.66	23,800 [7.0]	2.60	8.20
	RCHJ-36A1 (RGFD-12?RCM?)	34,600 [10.1]	24,050 [7.0]	10,550 [3.1]	11.60	13.00	74	1,225 [578]	37,200 [10.9]	3.66	23,800 [7.0]	2.60	8.20
	RCHJ-36A1 (RGGD-09?ZCM?)	34,600 [10.1]	24,050 [7.0]	10,550 [3.1]	11.65	13.00	74	1,175 [554]	36,400 [10.7]	3.90	23,000 [6.7]	2.74	8.20
	RCHJ-36A1 (RGGD-10?ZCM?)	34,600 [10.1]	24,050 [7.0]	10,550 [3.1]	11.65	13.00	74	1,175 [554]	36,400 [10.7]	3.90	23,000 [6.7]	2.74	8.20
	RCHJ-36A1 (RGGD-12?RCM?)	34,600 [10.1]	24,100 [7.1]	10,500 [3.1]	11.75	13.00	74	1,225 [578]	36,400 [10.7]	3.90	23,000 [6.7]	2.74	8.20
	RCHJ-36A1 (RGJD-09?ZCM?)	34,600 [10.1]	24,050 [7.0]	10,550 [3.1]	11.65	13.00	74	1,175 [554]	36,400 [10.7]	3.88	23,000 [6.7]	2.74	8.20
	RCHJ-36A1 (RGJD-10?ZCM?)	34,600 [10.1]	24,050 [7.0]	10,550 [3.1]	11.65	13.00	74	1,175 [554]	36,400 [10.7]	3.88	23,000 [6.7]	2.74	8.20
	RCHJ-36A1 (RGJD-12?RCM?)	34,600 [10.1]	24,100 [7.1]	10,500 [3.1]	11.75	13.00	74	1,225 [578]	36,400 [10.7]	3.88	23,000 [6.7]	2.74	8.20
	RCHJ-36A1 (RGLR-07?AMK?)	34,400 [10.1]	23,900 [7.0]	10,500 [3.1]	11.35	13.00	74	1,200 [566]	36,400 [10.7]	3.88	23,000 [6.7]	2.74	8.20
	RCHJ-36A1 (RGLR-10?BRM?)	34,600 [10.1]	24,100 [7.1]	10,500 [3.1]	11.80	13.00	74	1,200 [566]	36,400 [10.7]	3.88	23,000 [6.7]	2.74	8.20
	RCHJ-36A1 (RGLR-12?ARM?)	34,800 [10.2]	24,150 [7.1]	10,650 [3.1]	11.85	13.00	74	1,225 [578]	36,400 [10.7]	3.88	23,000 [6.7]	2.74	8.20
	RCHJ-36A1 (RGPR-07?AMK?)	34,400 [10.1]	23,900 [7.0]	10,500 [3.1]	11.35	13.00	74	1,200 [566]	37,200 [10.9]	3.66	23,800 [7.0]	2.58	8.20
	RCHJ-36A1 (RGPR-07?BRQ?)	34,600 [10.1]	24,150 [7.1]	10,450 [3.1]	11.80	13.00	74	1,200 [566]	37,200 [10.9]	3.66	23,800 [7.0]	2.58	8.20
	RCHJ-36A1 (RGPR-10?BRM?)	34,600 [10.1]	24,050 [7.0]	10,550 [3.1]	11.65	13.00	74	1,225 [578]	37,200 [10.9]	3.66	23,800 [7.0]	2.58	8.20
	RCHJ-36A1 (RGPR-12?ARM?)	34,800 [10.2]	24,250 [7.1]	10,550 [3.1]	11.80	13.00	74	1,250 [590]	37,200 [10.9]	3.68	23,600 [6.9]	2.60	8.20
	17AHLA36HM (RCSA-H*3617A*)	36,000 [10.5]	25,350 [7.4]	10,650 [3.1]	11.95	13.50	74	1,200 [566]	37,200 [10.9]	3.64	23,600 [6.9]	2.56	8.85
	17AHTSA36HM (RCSA-H*3617A*)	35,400 [10.4]	24,950 [7.3]	10,450 [3.1]	11.25	13.00	74	1,175 [554]	37,800 [11.1]	3.50	24,200 [7.1]	2.46	8.50
	RHKA-HM3617 (RCSA-H*3617A*)	36,000 [10.5]	25,450 [7.5]	10,550 [3.1]	11.80	13.50	74	1,225 [578]	37,400 [11.0]	3.62	23,800 [7.0]	2.54	8.80
	RHLA-HM3617 (RCSA-H*3617A*)	36,000 [10.5]	25,350 [7.4]	10,650 [3.1]	11.95	13.50	74	1,200 [566]	37,200 [10.9]	3.64	23,600 [6.9]	2.56	8.85
RHSA-HM3617 (RCSA-H*3617A*)	35,400 [10.4]	24,950 [7.3]	10,450 [3.1]	11.25	13.00	74	1,175 [554]	37,800 [11.1]	3.50	24,200 [7.1]	2.46	8.50	
RHSA-HM3621 (RCSA-H*3621A*)	35,400 [10.4]	24,950 [7.3]	10,450 [3.1]	11.25	13.00	74	1,175 [554]	37,800 [11.1]	3.50	24,200 [7.1]	2.46	8.50	
036JAZ	RHSA-HM3617 (RCSA-H*3617A*) ①	35,400 [10.4]	24,950 [7.3]	10,450 [3.1]	11.25	13.00	74	1,175 [554]	37,800 [11.1]	3.50	24,200 [7.1]	2.46	8.50
	RCFA-H*3617A*	35,200 [10.3]	24,750 [7.3]	10,450 [3.1]	11.10	13.00	74	1,175 [554]	37,600 [11.0]	3.50	24,000 [7.0]	2.46	8.40
	RCFA-H*3621A*	35,400 [10.4]	24,950 [7.3]	10,450 [3.1]	11.10	13.00	74	1,175 [554]	38,000 [11.1]	3.50	24,200 [7.1]	2.46	8.40

① Highest sales volume tested combination required by DOE test procedures.

[] Designates Metric Conversions

Performance Data ARI Standard Conditions—Single Phase (Scroll Compressor)

Note: Only these combinations of indoor/outdoor units are approved and any other combinations should not be used.

Model Numbers		ARI Cooling Performance							ARI Heating Performance (70°F [21°C] Indoor)				
		80°F [26.5°C] DB/67°F [19.5°C] WB Indoor Air 95°F [35°C] DB Outdoor Air							Outdoor Air 47°F [8.5°C] DB/ 43°F [6°C] WB DOE High Temp.		Outdoor Air 17°F [-8.5°C] DB/ 15°F [-9.5°C] WB DOE Low Temp.		DOE Region IV HSPF
Outdoor Unit RPNE-	Indoor Coil and/or Air Handler	Total Capacity BTU/H [kW]	Net Sens. BTU/H [kW]	Net Latent BTU/H [kW]	EER	SEER	Snd. Rate dB	Indoor CFM [L/s]	BTU/H [kW]	COP	BTU/H [kW]	COP	
Rev. 3/25/2008													
036JAZ	RCFA-H*3621A* (RGFD-09?ZCM?)	35,800 [10.5]	25,250 [7.4]	10,550 [3.1]	11.70	13.50	74	1,150 [543]	37,400 [11.0]	3.62	23,800 [7.0]	2.54	8.80
	RCFA-H*3621A* (RGGD-09?ZCM?)	35,800 [10.5]	25,200 [7.4]	10,600 [3.1]	11.70	13.50	74	1,175 [554]	37,400 [11.0]	3.62	23,800 [7.0]	2.54	8.80
	RCFA-H*3621A* (RGGD-10?ZCM?)	35,800 [10.5]	25,250 [7.4]	10,550 [3.1]	11.75	13.50	74	1,175 [554]	37,400 [11.0]	3.62	23,800 [7.0]	2.54	8.80
	RCFA-H*3621A* (RGJD-09?ZCM?)	35,800 [10.5]	25,200 [7.4]	10,600 [3.1]	11.70	13.50	74	1,175 [554]	37,400 [11.0]	3.62	23,800 [7.0]	2.54	8.80
	RCFA-H*3621A* (RGJD-10?ZCM?)	35,800 [10.5]	25,250 [7.4]	10,550 [3.1]	11.75	13.50	74	1,175 [554]	37,400 [11.0]	3.62	23,800 [7.0]	2.54	8.80
	RCFA-H*3621A* (RGLR-07?BRQ?)	36,800 [10.8]	26,900 [7.9]	9,900 [2.9]	11.90	13.50	74	1,225 [578]	37,400 [11.0]	3.62	23,800 [7.0]	2.54	8.85
	RCFA-H*3621A* (RGLR-10?BRM?)	35,800 [10.5]	25,300 [7.4]	10,500 [3.1]	11.85	13.50	74	1,200 [566]	37,200 [10.9]	3.64	23,600 [6.9]	2.54	8.85
	RCFA-H*3621A* (RGPR-07?BRQ?)	36,000 [10.5]	25,300 [7.4]	10,700 [3.1]	11.85	13.50	74	1,200 [566]	37,200 [10.9]	3.64	23,600 [6.9]	2.56	8.85
	RCFA-H*3621A* (RGPR-10?BRM?)	36,000 [10.5]	25,400 [7.4]	10,600 [3.1]	11.70	13.50	74	1,225 [578]	37,400 [11.0]	3.60	23,800 [7.0]	2.52	8.75
	RBHP-21 (RCHJ-36A1)	34,600 [10.1]	24,050 [7.0]	10,550 [3.1]	11.80	13.50	74	1,225 [578]	37,200 [10.9]	3.68	23,600 [6.9]	2.60	8.20
	RCHJ-36A1 (RGFD-09?ZCM?)	34,400 [10.1]	23,850 [7.0]	10,550 [3.1]	11.60	13.00	74	1,150 [543]	37,200 [10.9]	3.66	23,800 [7.0]	2.60	8.20
	RCHJ-36A1 (RGFD-10?ZCM?)	34,400 [10.1]	24,000 [7.0]	10,400 [3.0]	11.50	13.00	74	1,175 [554]	37,200 [10.9]	3.66	23,800 [7.0]	2.60	8.20
	RCHJ-36A1 (RGFD-12?RCM?)	34,600 [10.1]	24,050 [7.0]	10,550 [3.1]	11.60	13.00	74	1,225 [578]	37,200 [10.9]	3.66	23,800 [7.0]	2.60	8.20
	RCHJ-36A1 (RGGD-09?ZCM?)	34,600 [10.1]	24,050 [7.0]	10,550 [3.1]	11.65	13.00	74	1,175 [554]	36,400 [10.7]	3.90	23,000 [6.7]	2.74	8.20
	RCHJ-36A1 (RGGD-10?ZCM?)	34,600 [10.1]	24,050 [7.0]	10,550 [3.1]	11.65	13.00	74	1,175 [554]	36,400 [10.7]	3.90	23,000 [6.7]	2.74	8.20
	RCHJ-36A1 (RGGD-12?RCM?)	34,600 [10.1]	24,100 [7.1]	10,500 [3.1]	11.75	13.00	74	1,225 [578]	36,400 [10.7]	3.90	23,000 [6.7]	2.74	8.20
	RCHJ-36A1 (RGJD-09?ZCM?)	34,600 [10.1]	24,050 [7.0]	10,550 [3.1]	11.65	13.00	74	1,175 [554]	36,400 [10.7]	3.88	23,000 [6.7]	2.74	8.20
	RCHJ-36A1 (RGJD-10?ZCM?)	34,600 [10.1]	24,050 [7.0]	10,550 [3.1]	11.65	13.00	74	1,175 [554]	36,400 [10.7]	3.88	23,000 [6.7]	2.74	8.20
	RCHJ-36A1 (RGJD-12?RCM?)	34,600 [10.1]	24,100 [7.1]	10,500 [3.1]	11.75	13.00	74	1,225 [578]	36,400 [10.7]	3.88	23,000 [6.7]	2.74	8.20
	RCHJ-36A1 (RGLR-07?AMK?)	34,400 [10.1]	23,900 [7.0]	10,500 [3.1]	11.35	13.00	74	1,200 [566]	36,400 [10.7]	3.88	23,000 [6.7]	2.74	8.20
	RCHJ-36A1 (RGLR-10?BRM?)	34,600 [10.1]	24,100 [7.1]	10,500 [3.1]	11.80	13.00	74	1,200 [566]	36,400 [10.7]	3.88	23,000 [6.7]	2.74	8.20
	RCHJ-36A1 (RGLR-12?ARM?)	34,800 [10.2]	24,150 [7.1]	10,650 [3.1]	11.85	13.00	74	1,225 [578]	36,400 [10.7]	3.88	23,000 [6.7]	2.74	8.20
	RCHJ-36A1 (RGPR-07?AMK?)	34,400 [10.1]	23,900 [7.0]	10,500 [3.1]	11.35	13.00	74	1,200 [566]	37,200 [10.9]	3.66	23,800 [7.0]	2.58	8.20
	RCHJ-36A1 (RGPR-07?BRQ?)	34,600 [10.1]	24,150 [7.1]	10,450 [3.1]	11.80	13.00	74	1,200 [566]	37,200 [10.9]	3.66	23,800 [7.0]	2.58	8.20
	RCHJ-36A1 (RGPR-10?BRM?)	34,600 [10.1]	24,050 [7.0]	10,550 [3.1]	11.65	13.00	74	1,225 [578]	37,200 [10.9]	3.66	23,800 [7.0]	2.58	8.20
	RCHJ-36A1 (RGPR-12?ARM?)	34,800 [10.2]	24,250 [7.1]	10,550 [3.1]	11.80	13.00	74	1,250 [590]	37,200 [10.9]	3.68	23,600 [6.9]	2.60	8.20
	17AHLA36HM (RCSA-H*3617A*)	36,000 [10.5]	25,350 [7.4]	10,650 [3.1]	11.95	13.50	74	1,200 [566]	37,200 [10.9]	3.64	23,600 [6.9]	2.56	8.85
	17AHS36HM (RCSA-H*3617A*)	35,400 [10.4]	24,950 [7.3]	10,450 [3.1]	11.25	13.00	74	1,175 [554]	37,800 [11.1]	3.50	24,200 [7.1]	2.46	8.50
RHKA-HM3617 (RCSA-H*3617A*)	36,000 [10.5]	25,450 [7.5]	10,550 [3.1]	11.80	13.50	74	1,225 [578]	37,400 [11.0]	3.62	23,800 [7.0]	2.54	8.80	

① Highest sales volume tested combination required by DOE test procedures.

[] Designates Metric Conversions

Performance Data ARI Standard Conditions—Single Phase (Scroll Compressor)

Note: Only these combinations of indoor/outdoor units are approved and any other combinations should not be used.

Model Numbers		ARI Cooling Performance							ARI Heating Performance (70°F [21°C] Indoor)				
		80°F [26.5°C] DB/67°F [19.5°C] WB Indoor Air 95°F [35°C] DB Outdoor Air							Outdoor Air 47°F [8.5°C] DB/ 43°F [6°C] WB DOE High Temp.		Outdoor Air 17°F [-8.5°C] DB/ 15°F [-9.5°C] WB DOE Low Temp.		DOE Region IV HSPF
Outdoor Unit RPNE-	Indoor Coil and/or Air Handler	Total Capacity BTU/H [kW]	Net Sens. BTU/H [kW]	Net Latent BTU/H [kW]	EER	SEER	Snd. Rate dB	Indoor CFM [L/s]	BTU/H [kW]	COP	BTU/H [kW]	COP	
Rev. 3/25/2008													
036JAZ	RHLA-HM3617 (RCSA-H*3617A*)	36,000 [10.5]	25,350 [7.4]	10,650 [3.1]	11.95	13.50	74	1,200 [566]	37,200 [10.9]	3.64	23,600 [6.9]	2.56	8.85
	RHSA-HM3621 (RCSA-H*3621A*)	35,400 [10.4]	24,950 [7.3]	10,450 [3.1]	11.25	13.00	74	1,175 [554]	37,800 [11.1]	3.50	24,200 [7.1]	2.46	8.50
042CAZ	RCFA-H*4821A*	40,500 [11.9]	28,650 [8.4]	11,850 [3.5]	10.75	13.00	76	1,375 [649]	41,000 [12.0]	3.46	26,600 [7.8]	2.48	8.50
	RCFA-H*4821A* (RGLR-10?BRM?)	41,000 [12.0]	29,050 [8.5]	11,950 [3.5]	11.40	13.50	76	1,375 [649]	40,500 [11.9]	3.60	26,000 [7.6]	2.56	8.70
	RCFA-H*4824A*	40,500 [11.9]	28,650 [8.4]	11,850 [3.5]	10.75	13.00	76	1,375 [649]	41,000 [12.0]	3.46	26,600 [7.8]	2.48	8.50
	RCFA-H*4824A* (RGLR-10?BRM?)	41,000 [12.0]	29,050 [8.5]	11,950 [3.5]	11.40	13.50	76	1,375 [649]	40,500 [11.9]	3.60	26,000 [7.6]	2.56	8.80
	RCFA-H*4824A* (RGLR-12?ARM?)	41,500 [12.2]	29,200 [8.6]	12,300 [3.6]	11.40	13.50	76	1,425 [672]	40,500 [11.9]	3.60	26,000 [7.6]	2.56	8.80
	RCHJ-48A1 (RGLR-10?BRM?)	41,000 [12.0]	27,550 [8.1]	13,450 [3.9]	11.50	13.00	76	1,375 [649]	42,500 [12.5]	3.38	26,800 [7.9]	2.36	8.20
	RCHJ-48A1 (RGLR-12?ARM?)	41,000 [12.0]	27,700 [8.1]	13,300 [3.9]	11.55	13.00	76	1,425 [672]	42,500 [12.5]	3.42	26,600 [7.8]	2.38	8.20
	RCHJ-48A1 (RGPR-07?BRQ?)	41,000 [12.0]	27,500 [8.1]	13,500 [4.0]	11.40	13.00	76	1,400 [661]	42,500 [12.5]	3.36	27,000 [7.9]	2.34	8.20
	RCHJ-48A1 (RGPR-12?ARM?)	41,000 [12.0]	27,500 [8.1]	13,500 [4.0]	11.40	13.00	76	1,400 [661]	42,500 [12.5]	3.38	26,800 [7.9]	2.36	8.20
	21AHLA48HM (RCSA-H*4821A*)	41,000 [12.0]	29,150 [8.5]	11,850 [3.5]	11.60	13.50	76	1,400 [661]	40,500 [11.9]	3.64	25,800 [7.6]	2.58	8.75
	21AHS42HM (RCSA-H*4821A*)	40,500 [11.9]	28,650 [8.4]	11,850 [3.5]	10.95	13.00	76	1,375 [649]	41,000 [12.0]	3.50	26,400 [7.7]	2.48	8.50
	RHKA-HM4821 (RCSA-H*4821A*)	41,000 [12.0]	29,150 [8.5]	11,850 [3.5]	11.55	13.50	76	1,400 [661]	40,500 [11.9]	3.64	25,800 [7.6]	2.58	8.75
	RHLA-HM4821 (RCSA-H*4821A*)	41,000 [12.0]	29,150 [8.5]	11,850 [3.5]	11.60	13.50	76	1,400 [661]	40,500 [11.9]	3.64	25,800 [7.6]	2.58	8.75
	RHSA-HM4221 (RCSA-H*4821A*)	40,500 [11.9]	28,650 [8.4]	11,850 [3.5]	10.95	13.00	76	1,375 [649]	41,000 [12.0]	3.50	26,400 [7.7]	2.48	8.50
042DAZ	RCFA-H*4821A*	40,500 [11.9]	28,650 [8.4]	11,850 [3.5]	10.75	13.00	76	1,375 [649]	41,000 [12.0]	3.46	26,600 [7.8]	2.48	8.50
	RCFA-H*4821A* (RGLR-10?BRM?)	41,000 [12.0]	29,050 [8.5]	11,950 [3.5]	11.40	13.50	76	1,375 [649]	40,500 [11.9]	3.60	26,000 [7.6]	2.56	8.70
	RCFA-H*4824A*	40,500 [11.9]	28,650 [8.4]	11,850 [3.5]	10.75	13.00	76	1,375 [649]	41,000 [12.0]	3.46	26,600 [7.8]	2.48	8.50
	RCFA-H*4824A* (RGLR-10?BRM?)	41,000 [12.0]	29,050 [8.5]	11,950 [3.5]	11.40	13.50	76	1,375 [649]	40,500 [11.9]	3.60	26,000 [7.6]	2.56	8.80
	RCFA-H*4824A* (RGLR-12?ARM?)	41,500 [12.2]	29,200 [8.6]	12,300 [3.6]	11.40	13.50	76	1,425 [672]	40,500 [11.9]	3.60	26,000 [7.6]	2.56	8.80
	RCHJ-48A1 (RGLR-10?BRM?)	41,000 [12.0]	27,550 [8.1]	13,450 [3.9]	11.50	13.00	76	1,375 [649]	42,500 [12.5]	3.38	26,800 [7.9]	2.36	8.20
	RCHJ-48A1 (RGLR-12?ARM?)	41,000 [12.0]	27,700 [8.1]	13,300 [3.9]	11.55	13.00	76	1,425 [672]	42,500 [12.5]	3.42	26,600 [7.8]	2.38	8.20
	RCHJ-48A1 (RGPR-07?BRQ?)	41,000 [12.0]	27,500 [8.1]	13,500 [4.0]	11.40	13.00	76	1,400 [661]	42,500 [12.5]	3.36	27,000 [7.9]	2.34	8.20
	RCHJ-48A1 (RGPR-12?ARM?)	41,000 [12.0]	27,500 [8.1]	13,500 [4.0]	11.40	13.00	76	1,400 [661]	42,500 [12.5]	3.38	26,800 [7.9]	2.36	8.20
	21AHLA48HM (RCSA-H*4821A*)	41,000 [12.0]	29,150 [8.5]	11,850 [3.5]	11.60	13.50	76	1,400 [661]	40,500 [11.9]	3.64	25,800 [7.6]	2.58	8.75
	21AHS42HM (RCSA-H*4821A*)	40,500 [11.9]	28,650 [8.4]	11,850 [3.5]	10.95	13.00	76	1,375 [649]	41,000 [12.0]	3.50	26,400 [7.7]	2.48	8.50
	RHKA-HM4821 (RCSA-H*4821A*)	41,000 [12.0]	29,150 [8.5]	11,850 [3.5]	11.55	13.50	76	1,400 [661]	40,500 [11.9]	3.64	25,800 [7.6]	2.58	8.75
RHLA-HM4821 (RCSA-H*4821A*)	41,000 [12.0]	29,150 [8.5]	11,850 [3.5]	11.60	13.50	76	1,400 [661]	40,500 [11.9]	3.64	25,800 [7.6]	2.58	8.75	

① Highest sales volume tested combination required by DOE test procedures.

[] Designates Metric Conversions

Performance Data ARI Standard Conditions—Single Phase (Scroll Compressor)

Note: Only these combinations of indoor/outdoor units are approved and any other combinations should not be used.

Model Numbers		ARI Cooling Performance							ARI Heating Performance (70°F [21°C] Indoor)				
		80°F [26.5°C] DB/67°F [19.5°C] WB Indoor Air 95°F [35°C] DB Outdoor Air							Outdoor Air 47°F [8.5°C] DB/ 43°F [6°C] WB DOE High Temp.		Outdoor Air 17°F [-8.5°C] DB/ 15°F [-9.5°C] WB DOE Low Temp.		DOE Region IV HSPF
Outdoor Unit RPNE-	Indoor Coil and/or Air Handler	Total Capacity BTU/H [kW]	Net Sens. BTU/H [kW]	Net Latent BTU/H [kW]	EER	SEER	Snd. Rate dB	Indoor CFM [L/s]	BTU/H [kW]		COP		
									BTU/H [kW]	COP	BTU/H [kW]	COP	
Rev. 3/25/2008													
042DAZ	RHSA-HM4221 (RCSA-H*4821A*)	40,500 [11.9]	28,650 [8.4]	11,850 [3.5]	10.95	13.00	76	1,375 [649]	41,000 [12.0]	3.50	26,400 [7.7]	2.48	8.50
042JAZ	RHSA-HM4221 (RCSA-H*4821A*) ①	40,500 [11.9]	28,650 [8.4]	11,850 [3.5]	10.95	13.00	76	1,375 [649]	41,000 [12.0]	3.50	26,400 [7.7]	2.48	8.50
	RCFA-H*4821A*	40,500 [11.9]	28,650 [8.4]	11,850 [3.5]	10.75	13.00	76	1,375 [649]	41,000 [12.0]	3.46	26,600 [7.8]	2.48	8.50
	RCFA-H*4821A* (RGLR-10?BRM?)	41,000 [12.0]	29,050 [8.5]	11,950 [3.5]	11.40	13.50	76	1,375 [649]	40,500 [11.9]	3.60	26,000 [7.6]	2.56	8.70
	RCFA-H*4824A*	40,500 [11.9]	28,650 [8.4]	11,850 [3.5]	10.75	13.00	76	1,375 [649]	41,000 [12.0]	3.46	26,600 [7.8]	2.48	8.50
	RCFA-H*4824A* (RGLR-10?BRM?)	41,000 [12.0]	29,050 [8.5]	11,950 [3.5]	11.40	13.50	76	1,375 [649]	40,500 [11.9]	3.60	26,000 [7.6]	2.56	8.80
	RCFA-H*4824A* (RGLR-12?ARM?)	41,500 [12.2]	29,200 [8.6]	12,300 [3.6]	11.40	13.50	76	1,425 [672]	40,500 [11.9]	3.60	26,000 [7.6]	2.56	8.80
	RCHJ-48A1 (RGLR-10?BRM?)	41,000 [12.0]	27,550 [8.1]	13,450 [3.9]	11.50	13.00	76	1,375 [649]	42,500 [12.5]	3.38	26,800 [7.9]	2.36	8.20
	RCHJ-48A1 (RGLR-12?ARM?)	41,000 [12.0]	27,700 [8.1]	13,300 [3.9]	11.55	13.00	76	1,425 [672]	42,500 [12.5]	3.42	26,600 [7.8]	2.38	8.20
	RCHJ-48A1 (RGPR-07?BRQ?)	41,000 [12.0]	27,500 [8.1]	13,500 [4.0]	11.40	13.00	76	1,400 [661]	42,500 [12.5]	3.36	27,000 [7.9]	2.34	8.20
	RCHJ-48A1 (RGPR-12?ARM?)	41,000 [12.0]	27,500 [8.1]	13,500 [4.0]	11.40	13.00	76	1,400 [661]	42,500 [12.5]	3.38	26,800 [7.9]	2.36	8.20
	21AHLA48HM (RCSA-H*4821A*)	41,000 [12.0]	29,150 [8.5]	11,850 [3.5]	11.60	13.50	76	1,400 [661]	40,500 [11.9]	3.64	25,800 [7.6]	2.58	8.75
	21AHS42HM (RCSA-H*4821A*)	40,500 [11.9]	28,650 [8.4]	11,850 [3.5]	10.95	13.00	76	1,375 [649]	41,000 [12.0]	3.50	26,400 [7.7]	2.48	8.50
	RHKA-HM4821 (RCSA-H*4821A*)	41,000 [12.0]	29,150 [8.5]	11,850 [3.5]	11.55	13.50	76	1,400 [661]	40,500 [11.9]	3.64	25,800 [7.6]	2.58	8.75
	RHLA-HM4821 (RCSA-H*4821A*)	41,000 [12.0]	29,150 [8.5]	11,850 [3.5]	11.60	13.50	76	1,400 [661]	40,500 [11.9]	3.64	25,800 [7.6]	2.58	8.75
048CAZ	21AHLA48HM (RCSA-H*4821A*)	47,000 [13.8]	33,000 [9.7]	14,000 [4.1]	11.40	13.00	76	1,500 [708]	45,000 [13.2]	3.58	29,000 [8.5]	2.56	8.50
	RHKA-HM4821 (RCSA-H*4821A*)	46,500 [13.6]	32,700 [9.6]	13,800 [4.0]	11.35	13.00	76	1,400 [661]	45,000 [13.2]	3.60	28,800 [8.4]	2.60	8.50
	RHLA-HM4821 (RCSA-H*4821A*)	47,000 [13.8]	33,000 [9.7]	14,000 [4.1]	11.40	13.00	76	1,500 [708]	45,000 [13.2]	3.58	29,000 [8.5]	2.56	8.50
	24AHLA48HM (RCSA-H*4824A*)	48,000 [14.1]	33,600 [9.8]	14,400 [4.2]	11.60	13.00	76	1,625 [767]	45,000 [13.2]	3.58	29,000 [8.5]	2.58	8.50
	RHKA-HM4824 (RCSA-H*4824A*)	48,000 [14.1]	33,550 [9.8]	14,450 [4.2]	11.55	13.00	76	1,625 [767]	45,000 [13.2]	3.60	28,800 [8.4]	2.58	8.50
	RHLA-HM4824 (RCSA-H*4824A*)	48,000 [14.1]	33,600 [9.8]	14,400 [4.2]	11.60	13.00	76	1,625 [767]	45,000 [13.2]	3.58	29,000 [8.5]	2.58	8.50
048DAZ	21AHLA48HM (RCSA-H*4821A*)	47,000 [13.8]	33,000 [9.7]	14,000 [4.1]	11.40	13.00	76	1,500 [708]	45,000 [13.2]	3.58	29,000 [8.5]	2.56	8.50
	RHKA-HM4821 (RCSA-H*4821A*)	46,500 [13.6]	32,700 [9.6]	13,800 [4.0]	11.35	13.00	76	1,400 [661]	45,000 [13.2]	3.60	28,800 [8.4]	2.60	8.50
	RHLA-HM4821 (RCSA-H*4821A*)	47,000 [13.8]	33,000 [9.7]	14,000 [4.1]	11.40	13.00	76	1,500 [708]	45,000 [13.2]	3.58	29,000 [8.5]	2.56	8.50
	24AHLA48HM (RCSA-H*4824A*)	48,000 [14.1]	33,600 [9.8]	14,400 [4.2]	11.60	13.00	76	1,625 [767]	45,000 [13.2]	3.58	29,000 [8.5]	2.58	8.50
	RHKA-HM4824 (RCSA-H*4824A*)	48,000 [14.1]	33,550 [9.8]	14,450 [4.2]	11.55	13.00	76	1,625 [767]	45,000 [13.2]	3.60	28,800 [8.4]	2.58	8.50
	RHLA-HM4824 (RCSA-H*4824A*)	48,000 [14.1]	33,600 [9.8]	14,400 [4.2]	11.60	13.00	76	1,625 [767]	45,000 [13.2]	3.58	29,000 [8.5]	2.58	8.50
048JAZ	RHLA-HM4821 (RCSA-H*4821A*) ①	47,000 [13.8]	33,000 [9.7]	14,000 [4.1]	11.40	13.00	76	1,500 [708]	45,000 [13.2]	3.58	29,000 [8.5]	2.56	8.50
	21AHLA48HM (RCSA-H*4821A*)	47,000 [13.8]	33,000 [9.7]	14,000 [4.1]	11.40	13.00	76	1,500 [708]	45,000 [13.2]	3.58	29,000 [8.5]	2.56	8.50

① Highest sales volume tested combination required by DOE test procedures.

[] Designates Metric Conversions

Performance Data ARI Standard Conditions—Single Phase (Scroll Compressor)

Note: Only these combinations of indoor/outdoor units are approved and any other combinations should not be used.

Model Numbers		ARI Cooling Performance							ARI Heating Performance (70°F [21°C] Indoor)				
		80°F [26.5°C] DB/67°F [19.5°C] WB Indoor Air 95°F [35°C] DB Outdoor Air							Outdoor Air 47°F [8.5°C] DB/ 43°F [6°C] WB DOE High Temp.		Outdoor Air 17°F [-8.5°C] DB/ 15°F [-9.5°C] WB DOE Low Temp.		DOE Region IV HSPF
Outdoor Unit RPNE-	Indoor Coil and/or Air Handler	Total Capacity BTU/H [kW]	Net Sens. BTU/H [kW]	Net Latent BTU/H [kW]	EER	SEER	Snd. Rate dB	Indoor CFM [L/s]	BTU/H [kW]	COP	BTU/H [kW]	COP	
Rev. 3/25/2008													
048JAZ	RHKA-HM4821 (RCSA-H*4821A*)	46,500 [13.6]	32,700 [9.6]	13,800 [4.0]	11.35	13.00	76	1,400 [661]	45,000 [13.2]	3.60	28,800 [8.4]	2.60	8.50
	24AHLA48HM (RCSA-H*4824A*)	48,000 [14.1]	33,600 [9.8]	14,400 [4.2]	11.60	13.00	76	1,625 [767]	45,000 [13.2]	3.58	29,000 [8.5]	2.58	8.50
	RHKA-HM4824 (RCSA-H*4824A*)	48,000 [14.1]	33,550 [9.8]	14,450 [4.2]	11.55	13.00	76	1,625 [767]	45,000 [13.2]	3.60	28,800 [8.4]	2.58	8.50
	RHLA-HM4824 (RCSA-H*4824A*)	48,000 [14.1]	33,600 [9.8]	14,400 [4.2]	11.60	13.00	76	1,625 [767]	45,000 [13.2]	3.58	29,000 [8.5]	2.58	8.50
060CAZ	24AHLA60HM (RCSA-H*6024A*)	58,000 [17.0]	40,950 [12.0]	17,050 [5.0]	11.50	13.00	76	1,775 [838]	57,000 [16.7]	3.68	31,600 [9.3]	2.40	8.50
	RHKA-HM6024 (RCSA-H*6024A*)	58,000 [17.0]	41,050 [12.0]	16,950 [5.0]	11.40	13.00	76	1,800 [849]	57,000 [16.7]	3.68	31,600 [9.3]	2.40	8.50
	RHLA-HM6024 (RCSA-H*6024A*)	58,000 [17.0]	40,950 [12.0]	17,050 [5.0]	11.50	13.00	76	1,775 [838]	57,000 [16.7]	3.68	31,600 [9.3]	2.40	8.50
060DAZ	24AHLA60HM (RCSA-H*6024A*)	58,000 [17.0]	40,950 [12.0]	17,050 [5.0]	11.50	13.00	76	1,775 [838]	57,000 [16.7]	3.68	31,600 [9.3]	2.40	8.50
	RHKA-HM6024 (RCSA-H*6024A*)	58,000 [17.0]	41,050 [12.0]	16,950 [5.0]	11.40	13.00	76	1,800 [849]	57,000 [16.7]	3.68	31,600 [9.3]	2.40	8.50
	RHLA-HM6024 (RCSA-H*6024A*)	58,000 [17.0]	40,950 [12.0]	17,050 [5.0]	11.50	13.00	76	1,775 [838]	57,000 [16.7]	3.68	31,600 [9.3]	2.40	8.50
060JAZ	RHLA-HM6024 (RCSA-H*6024A*) #	58,000 [17.0]	40,950 [12.0]	17,050 [5.0]	11.50	13.00	76	1,775 [838]	57,000 [16.7]	3.68	31,600 [9.3]	2.40	8.50
	24AHLA60HM (RCSA-H*6024A*)	58,000 [17.0]	40,950 [12.0]	17,050 [5.0]	11.50	13.00	76	1,775 [838]	57,000 [16.7]	3.68	31,600 [9.3]	2.40	8.50
	RHKA-HM6024 (RCSA-H*6024A*)	58,000 [17.0]	41,050 [12.0]	16,950 [5.0]	11.40	13.00	76	1,800 [849]	57,000 [16.7]	3.68	31,600 [9.3]	2.40	8.50
060YAZ	RHLA-HM6024 (RCSA-H*6024A*) #	58,000 [17.0]	40,950 [12.0]	17,050 [5.0]	11.50	13.00	76	1,775 [838]	57,000 [16.7]	3.68	31,600 [9.3]	2.40	8.50
	RCFA-H*6024A*	57,500 [16.8]	40,450 [11.9]	17,050 [5.0]	10.80	12.00	76	1,775 [838]	58,000 [17.0]	3.54	32,400 [9.5]	2.32	8.25
	24AHLA60HM (RCSA-H*6024A*)	58,000 [17.0]	40,950 [12.0]	17,050 [5.0]	11.50	13.00	76	1,775 [838]	57,000 [16.7]	3.68	31,600 [9.3]	2.40	8.50
	RHKA-HM6024 (RCSA-H*6024A*)	58,000 [17.0]	41,050 [12.0]	16,950 [5.0]	11.40	13.00	76	1,800 [849]	57,000 [16.7]	3.68	31,600 [9.3]	2.40	8.50
	RHSA-HM6024 (RCSA-H*6024A*)	56,500 [16.6]	40,050 [11.7]	16,450 [4.8]	10.45	12.00	76	1,750 [826]	58,000 [17.0]	3.50	32,800 [9.6]	2.30	8.50

① Highest sales volume tested combination required by DOE test procedures.

[] Designates Metric Conversions

Electrical and Physical Data

Model Number RPNE-	ELECTRICAL								PHYSICAL					
	Phase Frequency (Hz) Voltage (Volts)	Compressor		Fan Motor Full Load Amperes (FLA)	Minimum Circuit Ampacity Amperes	Fuse or HACR Circuit Breaker		Outdoor Coil			Refrig. Per Circuit Oz. [g]	Weight		
		Rated Load Amperes (RLA)	Locked Rotor Amperes (LRA)			Minimum Amperes	Maximum Amperes	Face Area Sq. Ft. [m ²]	No. Rows	CFM [L/s]		Net Lbs. [kg]	Shipping Lbs. [kg]	
Rev. 3/25/2008														
018JAZ	1-60-208/230	9/9	41	0.6	12/12	15/15	20/20	11.00 [1.02]	1	1925 [908]	74 [2098]	160 [72.6]	170 [77.1]	
024JAZ	1-60-208/230	12.5/12.5	54	0.8	17/17	20/20	25/25	12.94 [1.20]	1	2475 [1168]	90 [2552]	159 [72.1]	169 [76.7]	
030JAZ	1-60-208/230	18.1/18.1	72.5	0.8	24/24	30/30	40/40	20.13 [1.87]	1	2650 [1251]	129 [3657]	207 [93.9]	217 [98.4]	
036CAZ	3-60-208/230	11.8/11.8	77	0.8	16/16	20/20	25/25	23.01 [2.14]	1	3000 [1416]	139 [3941]	230 [104.3]	240 [108.9]	
036DAZ	3-60-460	5.7	39	0.4	8	15	15	23.01 [2.14]	1	3000 [1416]	139 [3941]	230 [104.3]	240 [108.9]	
036JAZ	1-60-208/230	16.8/16.8	88	0.8	22/22	30/30	35/35	23.01 [2.14]	1	3000 [1416]	139 [3941]	230 [104.3]	240 [108.9]	
042CAZ	3-60-208/230	14.4/14.4	88	1.2	20/20	25/25	30/30	23.01 [2.14]	1	3575 [1687]	146 [4139]	239 [108.4]	249 [112.9]	
042DAZ	3-60-460	7.4	44	0.6	10	15	15	23.01 [2.14]	1	3575 [1687]	146 [4139]	239 [108.4]	249 [112.9]	
042JAZ	1-60-208/230	22.7/22.7	104	1.2	30/30	40/40	50/50	23.01 [2.14]	1	3575 [1687]	146 [4139]	239 [108.4]	249 [112.9]	
048CAZ	3-60-208/230	15.1/15.1	91	1.2	20/20	25/25	35/35	23.01 [2.14]	1	3575 [1687]	155 [4394]	240 [108.9]	250 [113.4]	
048DAZ	3-60-460	7.7	46	0.6	11	15	15	23.01 [2.14]	1	3575 [1687]	155 [4394]	240 [108.9]	250 [113.4]	
048JAZ	1-60-208/230	23.4/23.4	137	1.2	31/31	40/40	50/50	23.01 [2.14]	1	3575 [1687]	155 [4394]	243 [110.2]	253 [114.8]	
060CAZ	3-60-208/230	17.3/17.3	123	1.2	23/23	30/30	40/40	23.01 [2.14]	2	3350 [1581]	306 [8675]	280 [127]	290 [131.5]	
060DAZ	3-60-460	6.7	49.5	0.6	10	15	15	23.01 [2.14]	2	3350 [1581]	306 [8675]	308 [139.7]	318 [144.2]	
060JAZ	1-60-208/230	25/25	148	1.2	33/33	40/40	50/50	23.01 [2.14]	2	3350 [1581]	306 [8675]	308 [139.7]	318 [144.2]	
060YAZ	3-60-575	5.8	40	0.5	8	15	15	23.01 [2.14]	2	3350 [1581]	306 [8675]	308 [139.7]	318 [144.2]	

[] Designates Metric Conversions

Unit Dimensions

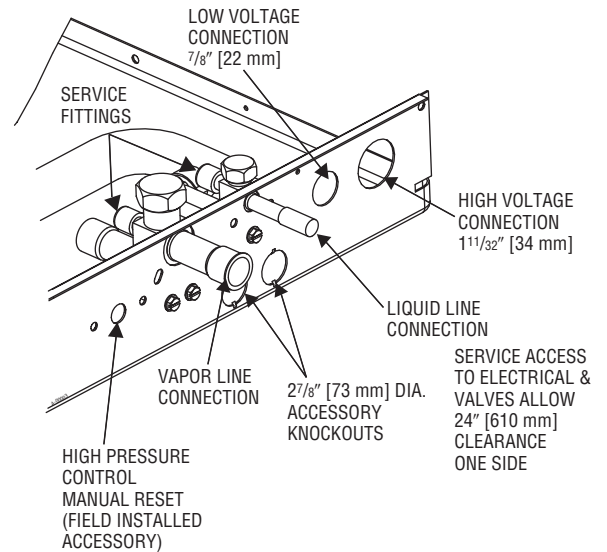
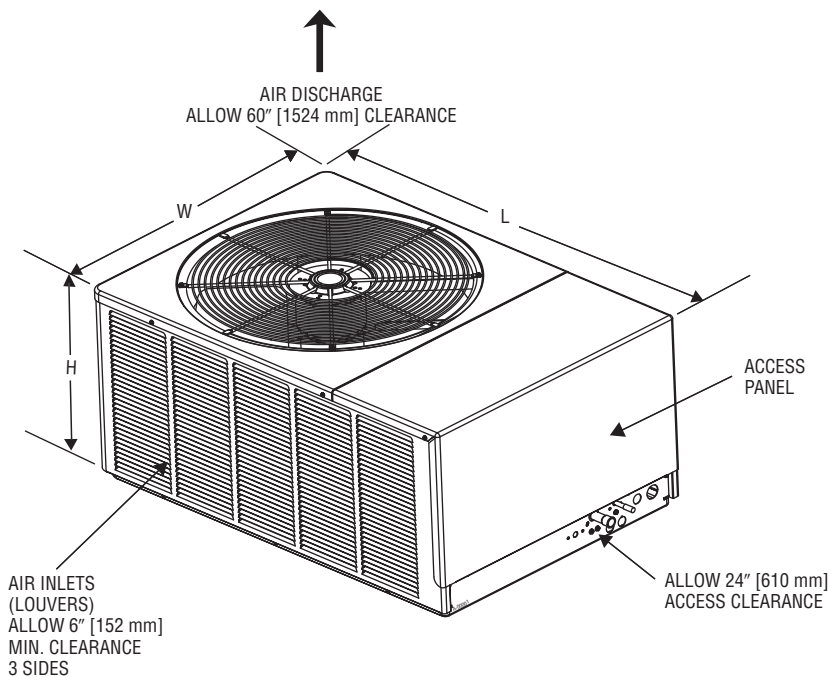

Model Number RPNE-	Height "H" (Inches) [mm]	Length "L" (Inches) [mm]	Width "W" (Inches) [mm]
018	19 [482]	40 1/2 [1028]	27 5/8 [701]
024	19 [482]	44 3/8 [1127]	31 1/2 [800]
030	29 [736]	44 3/8 [1127]	31 1/2 [800]
036/042/048/060	33 [838]	44 3/8 [1127]	31 1/2 [800]

Heat Pump Refrigerant Line Size Information

R-22 System Capacity Model	Liquid Line Connection Size (Inch I.D.)	Line Size (Inch O.D.) [mm]	Liquid Line Size Outdoor Unit Above or Below Indoor Coil (Heat Pumps Only)					
			Total Equivalent Length—Feet [m]					
			25 [7.62]	50 [15.24]	75 [22.86]	100 [30.48]	125 [38.10]	150 [45.72]
			Maximum Vertical Separation—Feet [m]					
1 1/2 Ton	3/8"	1/4 [6.35]	21 [6.40]	8 [2.44]	N/A	N/A	N/A	N/A
		5/16 [7.94]	25 [7.62]	27 [8.23]	24 [7.32]	21 [6.40]	17 [5.18]	14 [4.27]
		3/8* [9.53]	25 [7.62]	40 [12.19]	39 [11.89]	38 [11.58]	37 [11.28]	35 [10.67]
2 Ton	3/8"	1/4 [6.35]	16 [4.88]	N/A	N/A	N/A	N/A	N/A
		5/16 [7.94]	25 [7.62]	26 [7.92]	21 [6.40]	15 [4.57]	10 [3.05]	5 [1.52]
		3/8* [9.53]	25 [7.62]	38 [11.58]	36 [10.97]	35 [10.67]	33 [10.06]	31 [9.45]
2 1/2 Ton	3/8"	1/4 [6.35]	0	N/A	N/A	N/A	N/A	N/A
		5/16 [7.94]	25 [7.62]	17 [5.18]	8 [2.44]	0	N/A	N/A
		3/8* [9.53]	25 [7.62]	37 [11.28]	34 [10.36]	31 [9.45]	29 [8.84]	26 [7.92]
3 Ton	3/8"	5/16 [7.94]	25 [7.62]	15 [4.57]	4 [1.22]	N/A	N/A	N/A
		3/8* [9.53]	25 [7.62]	30 [9.14]	26 [7.92]	23 [7.01]	19 [5.79]	16 [4.88]
3 1/2 Ton	3/8"	5/16 [7.94]	25 [7.62]	17 [5.18]	2 [0.61]	N/A	N/A	N/A
		3/8* [9.53]	25 [7.62]	37 [11.28]	32 [9.75]	28 [8.53]	23 [7.01]	18 [5.49]
4 Ton	3/8"	3/8* [9.53]	25 [7.62]	33 [10.06]	27 [8.23]	21 [6.40]	15 [4.57]	9 [2.74]
		1/2 [12.7]	25 [7.62]	43 [13.11]	42 [12.80]	40 [12.19]	39 [11.89]	38 [11.58]
5 Ton	3/8"	3/8* [9.53]	25 [7.62]	25 [7.62]	17 [5.18]	8 [2.44]	0	N/A
		1/2 [12.7]	25 [7.62]	39 [11.89]	37 [11.28]	36 [10.97]	34 [10.36]	32 [9.75]

NOTES: *Standard line size
N/A - Application not recommended.

Suction Line Length/Size versus Capacity Multiplier (R-22)								
Unit Size	1 1/2 Ton	2 Ton	2 1/2 Ton	3 Ton	3 1/2 Ton	4 Ton	5 ton	
Unit Suction Line Connection Size	3/4" [19.05 mm] I.D. Sweat			7/8" [22.23 mm] I.D. Sweat		7/8" [22.23 mm] I.D. Sweat		
Suction Line Run—Feet [m]	5/8" [15.88 mm] O.D. Optional 3/4" [19.05 mm] O.D. Standard*	5/8" [15.88 mm] O.D. Optional 3/4" [19.05 mm] O.D. Standard* 7/8" [22.23 mm] O.D. Optional	3/4" [19.05 mm] O.D. Optional 7/8" [22.23 mm] O.D. Standard*	3/4" [19.05 mm] O.D. Optional 7/8" [22.23 mm] O.D. Standard*	3/4" [19.05 mm] O.D. Optional 7/8" [22.23 mm] O.D. Standard* 1 1/8" [28.58 mm] O.D. Optional	7/8" [22.23 mm] O.D. Optional 1 1/8" [28.58 mm] O.D. Standard*	—	
25' [7.62]	Optional Standard Optional	0.99 1.00 —	0.99 1.00 1.00	0.98 1.00 1.00	0.99 1.00 —	0.99 1.00 1.00	0.99 1.00 —	0.99 1.00 —
50' [15.24]	Optional Standard Optional	0.97 0.99 —	0.96 0.99 0.99	0.96 0.98 0.99	0.98 0.99 —	0.97 0.98 1.00	0.98 0.99 —	0.97 0.99 —
100' [30.48]	Optional Standard Optional	0.94 0.96 —	0.92 0.96 0.97	0.94 0.96 0.97	0.95 0.96 —	0.93 0.96 0.98	0.95 0.98 —	0.95 0.98 —
150' [45.72]	Optional Standard Optional	0.90 0.93 —	0.89 0.93 0.95	0.92 0.93 0.95	0.93 0.94 —	0.92 0.94 0.96	0.93 0.96 —	0.93 0.96 —

NOTES: *Standard line size
N/A - Line size not recommended due to inadequate oil return.

[] Designates Metric Conversions

BEFORE PURCHASING THIS APPLIANCE, READ IMPORTANT ENERGY COST AND EFFICIENCY INFORMATION AVAILABLE FROM YOUR RETAILER.

GENERAL TERMS OF LIMITED WARRANTY

Rheem will furnish a replacement for any part of this product which fails in normal use and service within the applicable period stated, in accordance with the terms of the limited warranty.

For Complete Details of the Limited Warranty, Including Applicable Terms and Conditions, See Your Local Installer or Contact the Manufacturer for a Copy.

Condenser Coil leaks caused by
factory defects.....Five (5) Years
Compressor.....Ten (10) Years
*Any Other PartFive (5) Years

*This five year limited warranty is applicable only to single-phase products installed in residential applications on or after January 1, 2001.

Before proceeding with installation, refer to installation instructions packaged with each model, as well as complying with all Federal, State, Provincial, and Local codes, regulations, and practices.

**Rheem Heating,
Cooling and
Water Heating**

P.O. Box 17010, Fort Smith, AR 72917



"In keeping with its policy of continuous progress and product improvement, Rheem reserves the right to make changes without notice."