

INSTALLATION INSTRUCTIONS

HEAT PUMP OUTDOOR UNITS:

(-)PNE 13 SEER MODEL SERIES

(-)PPC 14 SEER MODEL SERIES



RECOGNIZE THIS SYMBOL AS AN INDICATION OF IMPORTANT SAFETY INFORMATION!

WARNING

These instructions are intended as an aid to qualified, licensed service personnel for proper installation, adjustment and operation of this unit. Read these instructions thoroughly before attempting installation or operation. Failure to follow these instructions may result in improper installation, adjustment, service or maintenance possibly resulting in fire, electrical shock, property damage, personal injury or death.



(14 SEER MODELS)
(13 SEER IN CERTAIN
MATCHED SYSTEMS)



ISO 9001:2000

Certificate Number: 30164

DO NOT DESTROY THIS MANUAL

PLEASE READ CAREFULLY AND KEEP IN A SAFE PLACE FOR FUTURE REFERENCE BY A SERVICEMAN

TABLE OF CONTENTS

1.0 SAFETY INFORMATION	3
2.0 GENERAL INFORMATION	4
2.1 Checking Product Received	4
2.2 Application	4
2.3 Dimensions	5
2.4 Electrical and Physical Data	6
3.0 LOCATING UNIT	6
3.1 Corrosive Environment	6
3.2 Heat Pump Location	7
3.3 Operational Issues	7
3.4 For Units With Space Limitations	7
3.5 Customer Satisfaction Issues	8
3.6 Unit Mounting	8
3.7 Factory-Preferred Tie-Down Method	8
4.0 REFRIGERANT CONNECTIONS	9
5.0 REPLACEMENT UNITS	9
6.0 INDOOR COIL	10
6.1 Location	10
7.0 INTERCONNECTING TUBING	10
7.1 Vapor & Liquid Lines	10
7.2 Maximum Length of Lines	10
7.3 Outdoor Unit Installed Above Indoor Coil	10
7.4 Outdoor Unit Installed Below Indoor Coil	11
7.5 Tubing Installation	11
7.6 Tubing Connections	12
7.7 Leak Testing	12
8.0 DEMAND DEFROST CONTROL	14
8.1 Defrost Initiation	14
8.2 Defrost Termination	14
8.3 Temperature Sensors	14
8.4 Test Mode	14
8.5 Trouble Shooting Demand Defrost	14
8.6 High/Low Pressure Control Monitoring - Enhanced Defrost Control Only	15
8.7 Enhanced Feature Defrost Control Diagnostic Codes	15
9.0 EVACUATION PROCEDURE	15
10.0 START UP & PERFORMANCE	16
11.0 CHECKING AIRFLOW	16
12.0 CHECKING REFRIGERANT CHARGE	16
12.1 Charging By Liquid Pressure	16
12.2 Charging By Weight	17
12.3 Final Leak Testing	17
13.0 ELECTRICAL WIRING	17
13.1 Power Wiring	17
13.2 Grounding	18
13.3 Control Wiring	18
14.0 FIELD INSTALLED ACCESSORIES	18
14.1 Compressor Crankcase Heater	18
14.2 Hard Start Components	19
14.3 Time Delay Control (TDC)	19
14.4 Low Ambient Control (LAC)	19
14.5 High Pressure Controls (HPC)	19
14.6 Enhanced Compressor Protection Kit – RXPg-A01	19
15.0 TROUBLESHOOTING	20
15.1 Electrical Checks Flow Chart	20
15.2 Cooling Mechanical Checks Flow Chart	21
15.3 Heating Mechanical Checks Flow Chart	22
15.4 Defrost Mechanical Checks Flow Chart	23
15.5 Subcooling Calculation	24
15.6 General Troubleshooting Chart	25
15.7 Service Analyzer Chart	26
16.0 WIRING DIAGRAMS	31

1.0 SAFETY INFORMATION

WARNING

These instructions are intended as an aid to qualified, licensed service personnel for proper installation, adjustment and operation of this unit. Read these instructions thoroughly before attempting installation or operation. Failure to follow these instructions may result in improper installation, adjustment, service or maintenance possibly resulting in fire, electrical shock, property damage, personal injury or death.

WARNING

The manufacturer's warranty does not cover any damage or defect to the air conditioner caused by the attachment or use of any components. Accessories or devices (other than those authorized by the manufacturer) into, onto or in conjunction with the air conditioner. You should be aware that the use of unauthorized components, accessories or devices may adversely affect the operation of the air conditioner and may also endanger life and property. The manufacturer disclaims any responsibility for such loss or injury resulting from the use of such unauthorized components, accessories or devices.

WARNING

Disconnect all power to unit before starting maintenance. Failure to do so can cause electrical shock resulting in severe personal injury or death.

WARNING

Do not use oxygen to purge lines or pressurize system for leak test. Oxygen reacts violently with oil, which can cause an explosion resulting in severe personal injury or death.

WARNING

Turn off electric power at the fuse box or service panel before making any electrical connections.

Also, the ground connection must be completed before making line voltage connections. Failure to do so can result in electrical shock, severe personal injury or death.

WARNING

The unit must be permanently grounded. Failure to do so can cause electrical shock resulting in severe personal injury or death.

CAUTION

Secure elevated unit and elevating stand in order to prevent tipping. Failure to do this may result in minor or moderate injury.

CAUTION

When coil is installed over a finished ceiling and/or living area, it is recommended that a secondary sheet metal condensate pan be constructed and installed under entire unit. Failure to do so may result in property damage.

CAUTION

Single-pole contactors are used on all standard single-phase units up through 5 tons. Caution must be exercised when servicing as only one leg of the power supply is broken with the contactor. Two pole contactors are used on some three phase units.

2.0 GENERAL

WARNING

The manufacturer's warranty does not cover any damage or defect to the air conditioner caused by the attachment or use of any components. Accessories or devices (other than those authorized by the manufacturer) into, onto or in conjunction with the air conditioner. You should be aware that the use of unauthorized components, accessories or devices may adversely affect the operation of the air conditioner and may also endanger life and property. The manufacturer disclaims any responsibility for such loss or injury resulting from the use of such unauthorized components, accessories or devices.

The information contained in this manual has been prepared to assist in the proper installation, operation and maintenance of the heat pump equipment. Improper installation, or installation not made in accordance with these instructions, can result in unsatisfactory operation and/or dangerous conditions, and can cause the related warranty not to apply.

Read this manual and any instructions packaged with separate equipment required to make up the system prior to installation. Retain this manual for future reference.

To achieve optimum efficiency and capacity, the indoor cooling coils listed in the heat pump specification sheet should be used.

2.1 CHECKING PRODUCT RECEIVED

Upon receiving unit, inspect it for any shipping damage. Claims for damage, either apparent or concealed, should be filed immediately with the shipping company. Check heat pump model number, electrical characteristics and accessories to determine if they are correct. Check system components to make sure they are properly matched.

2.2 APPLICATION

Before installing any heat pump equipment, a duct analysis of the structure and a heat gain calculation must be made. A heat gain calculation begins by measuring all external surfaces and openings that gain heat from the surrounding air and quantifying that heat gain. A heat gain calculation also calculates the extra heat load caused by sunlight and by humidity removal.

There are several factors that installers must consider.

- Outdoor unit location
- Proper equipment evacuation
- Refrigerant charge
- Indoor unit air flow
- Indoor unit blower speed
- Supply and return air duct design and sizing
- System air balancing
- Diffuser and return air grille location and sizing

MATCH ALL COMPONENTS:

- OUTDOOR UNIT
- INDOOR COIL/METERING DEVICE
- INDOOR AIR HANDLER/FURNACE
- REFRIGERANT LINES

2.3 DIMENSIONS (SEE FIGURE 1)

FIGURE 1
DIMENSIONS AND INSTALLATION CLEARANCES

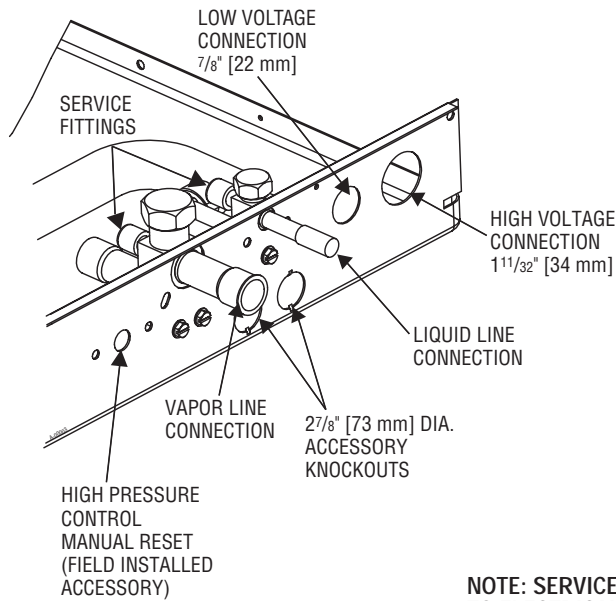
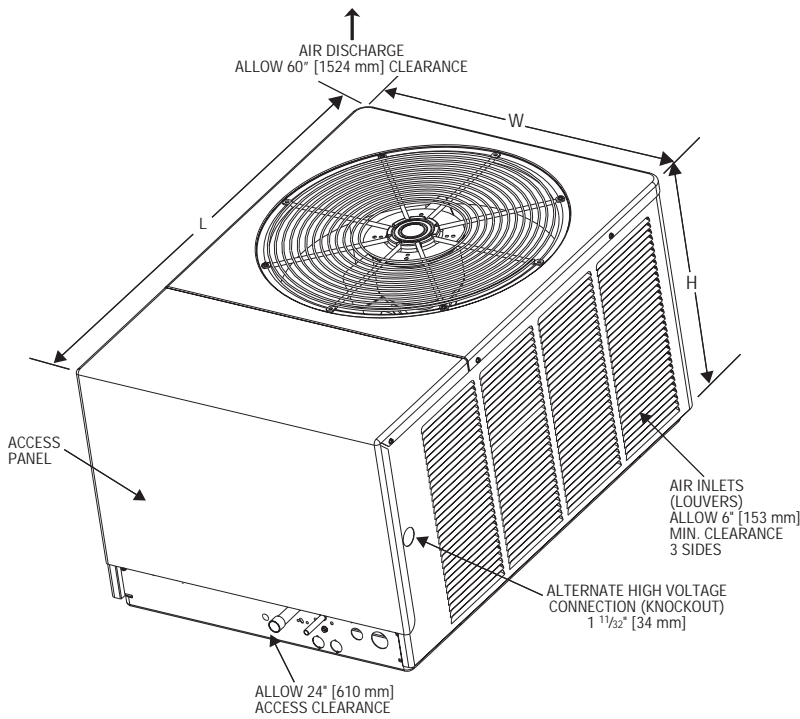

NOTE: SERVICE ACCESS TO ELECTRICAL & VALVES ALLOW 24" [610 mm] CLEARANCE ON SIDE

UNIT MODEL NUMBER EXPLANATION

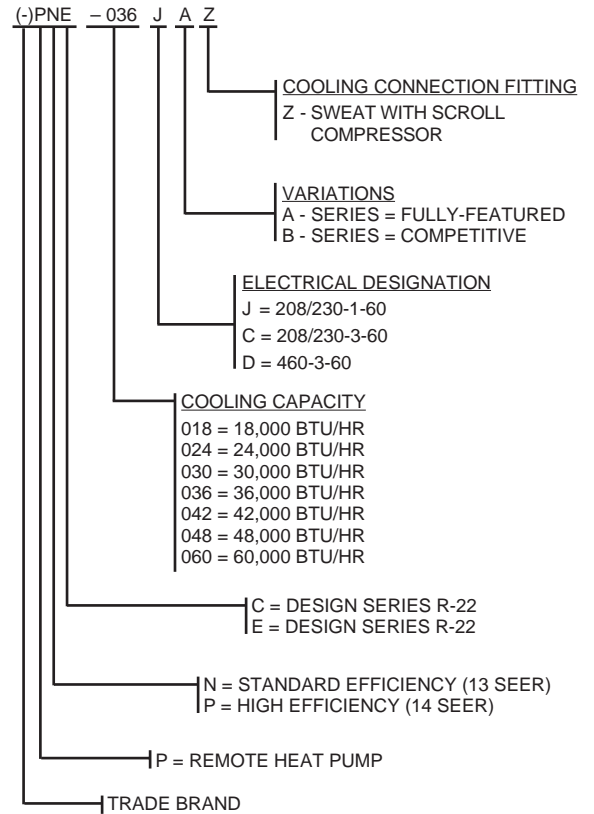

BASE PAN

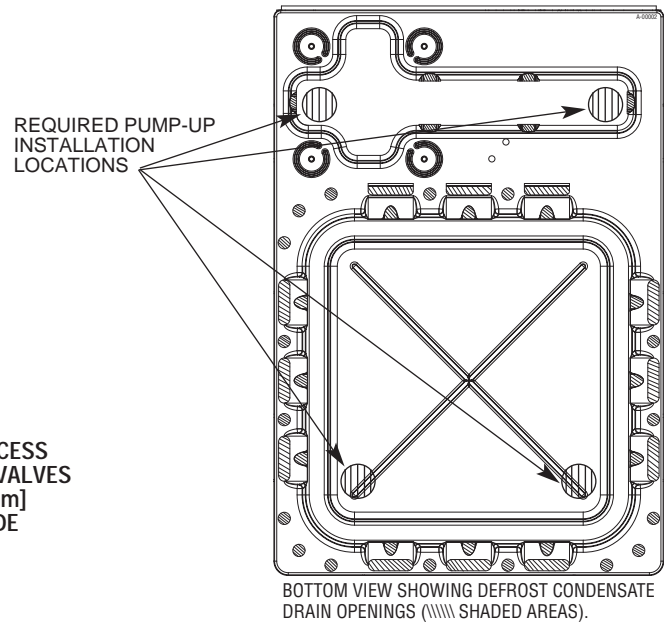

DIMENSIONAL DATA

HEAT PUMP MODEL	(-)PNE/ (-)PPC	018	024	030	036, 042, 048, 060
HEIGHT "H" (INCHES) [mm]		19" [482]	19" [482]	29" [736]	33" [838]
LENGTH "L" (INCHES) [mm]		40-1/2" [1028]	44-3/8" [1127]	44-3/8" [1127]	44-3/8" [1127]
WIDTH "W" (INCHES) [mm]		27-5/8" [701]	31-1/2" [800]	31-1/2" [800]	31-1/2" [800]

2.4 ELECTRICAL & PHYSICAL DATA (SEE TABLE 1 & 2)

Model Number (-)PNE-	ELECTRICAL							PHYSICAL					
	Phase Frequency (Hz) Voltage (Volts)	Compressor		Fan Motor Full Load Amperes (FLA)	Minimum Circuit Ampacity Amperes	Fuse or HACR Circuit Breaker		Outdoor Coil			R22 Oz. [g]	Weight	
		Rated Load Amperes (RLA)	Locked Rotor Amperes (LRA)			Minimum Amperes	Maximum Amperes	Face Area Sq. Ft. (m ²)	No. Rows	CFM [L/s]		Net Oz. [g]	Shipping Lbs. [kg]
018J*Z	1-60-208/230	9.0/9.0	41	0.6	12/12	15/15	20/20	11 [1.02]	1	1925 [908]	74 [2098]	130 [59]	140 [63]
024J*Z	1-60-208/230	12.5/12.5	54	0.8	17/17	20/20	25/25	12.94 [1.2]	1	2475 [1168]	90 [2552]	175 [79.4]	185 [83]
030J*Z	1-60-208/230	18.1/18.1	72.5	0.8	24/24	30/30	40/40	20.13 [1.87]	1	2650 [1251]	129 [3657]	200 [90.7]	210 [95]
036C*Z	3-60-208/230	42/42	77	0.8	16/16	25/25	20/20	23.01 [2.14]	1	3000 [1416]	139 [3941]	220 [99.8]	230 [104]
036D*Z	3-60-460	6.9	39	0.4	8	15	15	23.01 [2.14]	1	3000 [1416]	139 [3941]	220 [99.8]	230 [104]
036J*Z	1-60-208/230	20.5/20.5	88	0.8	22/22	30/30	35/35	23.01 [2.14]	1	3000 [1416]	139 [3941]	220 [99.8]	230 [104]
042C*Z	3-60-208/230	14.4/14.4	88	1.2	20/20	25/25	30/30	23.01 [2.14]	1	3575 [1687]	146 [4139]	230 [104.3]	240 [108]
042D*Z	3-60-460	7.4	44	0.6	10	15	15	23.01 [2.14]	1	3575 [1687]	146 [4139]	230 [104.3]	240 [108]
042J*Z	1-60-208/230	22.7/22.7	104	1.2	30/30	40/40	50/50	23.01 [2.14]	1	3575 [1687]	146 [4139]	230 [104.3]	240 [108]
048C*Z	3-60-208/230	15.1	91	1.2	20/20	25/25	35/35	23.01 [2.14]	1	3575 [1687]	155 [4394]	250 [113.4]	260 [117]
048D*Z	3-60-460	7.7	46	0.6	11	15	15	23.01 [2.14]	1	3575 [1687]	155 [4394]	250 [113.4]	260 [117]
048J*Z	1-60-208/230	23.4/23.4	137	1.2	31/31	40/40	50/50	23.01 [2.14]	1	3575 [1687]	155 [4394]	250 [113.4]	260 [117]
060C*Z	3-60-208/230	17.3/17.3	123	1.2	23/23	30/30	40/40	23.01 [2.14]	2	3350 [1581]	306 [8675]	280 [127]	290 [131]
060D*Z	3-60-460	6.7	49.5	0.6	10	15	15	23.01 [2.14]	2	3350 [1581]	306 [8675]	280 [127]	290 [131]
060J*Z	1-60-208/230	25.0/25.0	148	1.2	33/33	40/40	50/50	23.01 [2.14]	2	3350 [1581]	306 [8675]	280 [127]	290 [131]
060Y*Z	3-60-575	5.8	40	0.5	8	15	15	23.01 [2.14]	2	3350 [1581]	306 [8675]	280 [127]	290 [131]

Model Number (-)PPC-	ELECTRICAL							PHYSICAL					
	Phase Frequency (Hz) Voltage (Volts)	Compressor		Fan Motor Full Load Amperes (FLA)	Minimum Circuit Ampacity Amperes	Fuse or HACR Circuit Breaker		Outdoor Coil			Refrig. Per Circuit Oz. [g]	Weight	
		Rated Load Amperes (RLA)	Locked Rotor Amperes (LRA)			Minimum Amperes	Maximum Amperes	Face Area Sq. Ft. (m ²)	No. Rows	CFM [L/s]		Net Lbs. [kg]	Shipping Lbs. [kg]
018JAZ	1-60-208-230	9/9	41	0.6	12/12	15/15	20/20	11 [1.02]	1	1925 [908]	74 [2098]	130 [59]	140 [63.5]
024JAZ	1-60-208-230	12.5/12.5	54	0.8	17/17	20/20	25/25	12.94 [1.2]	1	2475 [1168]	90 [2552]	175 [79.4]	185 [83.9]
030JAZ	1-60-208-230	18.1/18.1	72.5	0.8	24/24	30/30	40/40	20.13 [1.87]	1	2650 [1251]	129 [3657]	200 [90.7]	210 [95.3]
036JAZ	1-60-208-230	20.5/20.5	88	0.8	27/27	35/35	45/45	23.01 [2.14]	1	3000 [1416]	139 [3941]	220 [99.8]	230 [104.3]
042JAZ	1-60-208-230	22.7/22.7	104	1.2	30/30	40/40	50/50	23.01 [2.14]	1	3575 [1687]	146 [4139]	230 [104.3]	240 [108.9]
048JAZ	1-60-208-230	19.1/19.1	109	1.2	26/26	30/30	40/40	23.01 [2.14]	2	3350 [1581]	255 [7371]	240 [115.7]	250 [120.2]
060JAZ	1-60-208-230	19.9/19.9	137	1.2	27/27	35/35	45/45	23.01 [2.14]	2	3350 [1581]	295 [8363]	255 [115.7]	265 [120.2]

3.0 LOCATING UNIT

3.1 CORROSIVE ENVIRONMENT

The metal parts of this unit may be subject to rust or deterioration if exposed to a corrosive environment. This oxidation could shorten the equipment's useful life. Corrosive elements include, but are not limited to, salt spray, fog or mist in seacoast areas, sulphur or chlorine from lawn watering systems, and various chemical contaminants from industries such as paper mills and petroleum refineries.

If the unit is to be installed in an area where contaminants are likely to be a problem, special attention should be given to the equipment location and exposure.

- Avoid having lawn sprinkler heads spray directly on the unit cabinet.
- In coastal areas, locate the unit on the side of the building away from the waterfront.
- Shielding provided by a fence or shrubs may give some protection, but cannot violate minimum airflow and service access clearances.
- Elevating the unit off its slab or base enough to allow air circulation will help avoid holding water against the basepan.

Regular maintenance will reduce the build-up of contaminants and help to protect the unit's finish.

WARNING

Disconnect all power to unit before starting maintenance. Failure to do so can cause electrical shock resulting in severe personal injury or death.

- Frequent washing of the cabinet, fan blade and coil with fresh water will remove most of the salt or other contaminants that build up on the unit.
- Regular cleaning and waxing of the cabinet with an automobile polish will provide some protection.
- A liquid cleaner may be used several times a year to remove matter that will not wash off with water.

Several different types of protective coil coatings are offered in some areas. These coatings may provide some benefit, but the effectiveness of such coating materials cannot be verified by the equipment manufacturer.

3.2 HEAT PUMP LOCATION

Consult local and national building codes and ordinances for special installation requirements. Following location information will provide longer life and simplified servicing of the outdoor heat pump.

NOTE: These units must be installed outdoors. No ductwork can be attached, or other modifications made, to the discharge grille. Modifications will affect performance or operation.

3.3 OPERATIONAL ISSUES

- **IMPORTANT:** Locate the unit in a manner that will not prevent, impair or compromise the performance of other equipment horizontally installed in proximity to the unit. Maintain all required minimum distances to gas and electric meters, dryer vents, exhaust and inlet openings. In the absence of National Codes, or manufacturers' recommendations, local code recommendations and requirements will take precedence.
- Refrigerant piping and wiring should be properly sized and kept as short as possible to avoid capacity losses and increased operating costs.
- Locate the unit where water run off will not create a problem with the equipment. Position the unit away from the drip edge of the roof whenever possible. Units are weatherized, but can be affected by the following:
 - o Water from the junction of rooflines, without protective guttering, entering the heat pump while in operation, can impact fan blade or motor life. Coil damage may occur to a heat pump if moisture cannot drain from the unit under freezing conditions.
 - o Freezing moisture, or sleeting conditions, can cause the cabinet to ice-over prematurely and prevent heat pump operation, requiring backup heat, which generally results in less economical operation.
- Closely follow clearance recommendations (see Figure 1).
 - o 24" to the service panel access
 - o 60" above heat pump fan discharge (unit top) to prevent recirculation
 - o 6" to heat pump coil grille air inlets (per heat pump).

3.4 FOR UNITS WITH SPACE LIMITATIONS

In the event that a space limitation exists, we will permit the following clearances:

Single Unit Applications: Heat pump grille side clearances below 6 inches will reduce unit capacity and efficiency. Do not reduce the 60-inch discharge, or the 24-inch service clearances.

Multiple Unit Applications: When multiple heat pump grille sides are aligned, a 6-inch per unit clearance is recommended, for a total of 12 inches between multiple units. Two combined clearances below 12 inches will reduce capacity and efficiency. Do not reduce the 60-inch discharge, or 24-inch service clearances.

- Do not obstruct the bottom drain opening in the heat pump base pan. It is essential to provide defrost condensate drainage to prevent possible refreezing of the condensation. Provide a base pad for mounting the unit, which is slightly pitched away from the structure. Route condensate off the base pad to an area which will not become slippery and result in personal injury.

- Where snowfall is anticipated, the heat pump must be elevated above the base pad to prevent ice buildup that may crush the tubing of the heat pump coil or cause fin damage. Heat pump units should be mounted above the average expected accumulated snowfall for the area.

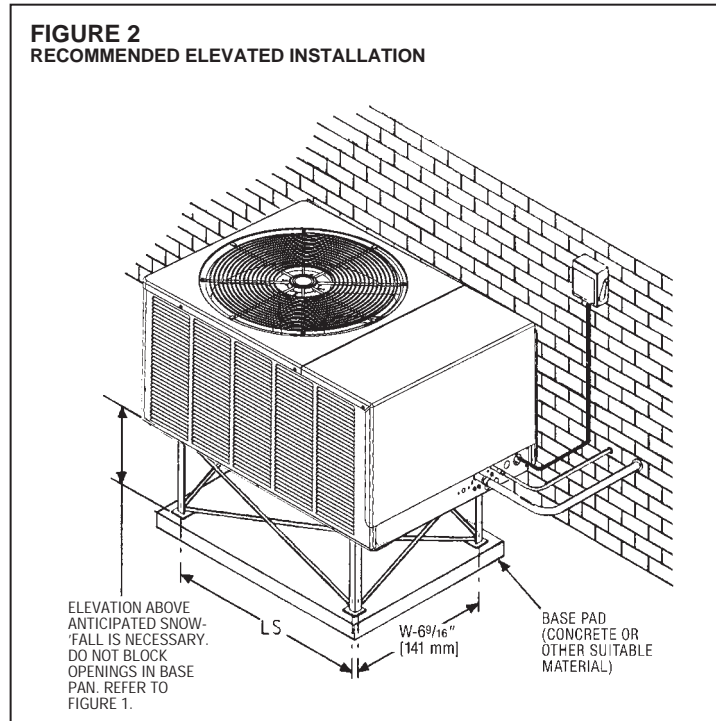

3.5 CUSTOMER SATISFACTION ISSUES

- The heat pump should be located away from the living, sleeping and recreational spaces of the owner and those spaces on adjoining property.
- To prevent noise transmission, the mounting pad for the outdoor unit should not be connected to the structure, and should be located sufficient distance above grade to prevent ground water from entering the unit.

3.6 UNIT MOUNTING

If elevating the heat pump, either on a flat roof or on a slab, observe the following guidelines. (See Figure 2.)

- The base pan provided elevates the heat pump 3/4" above the base pad.
- If elevating a unit on a flat roof, use 4" x 4" (or equivalent) stringers positioned to distribute unit weight evenly and prevent noise and vibration.

NOTE: Do not block drain openings shown in Figure 1.

- If unit must be elevated because of anticipated snow fall, secure unit and elevating stand such that unit and/or stand will not tip over or fall off.

⚠ CAUTION

Secure elevated unit and elevating stand in order to prevent tipping. Failure to do this may result in minor or moderate injury.

3.7 FACTORY-PREFERRED TIE-DOWN METHOD

INSTRUCTIONS

IMPORTANT: These instructions are intended as a guide to securing equipment for wind-load ratings of "120 MPH sustained wind load" and "3-second, 150 MPH gust." While this procedure is not mandatory, the Manufacturer does recommend that equipment be properly secured in areas where high wind damage may occur.

STEP 1: Before installing, clear pad of any dirt or debris.

IMPORTANT: The pad must be constructed of industry-approved materials, and must be thick enough to accommodate the concrete fastener.

STEP 2: Center base pan on pad, ensuring it is level.

STEP 3: Using basepad as a guide, mark spots on concrete where 4 holes will be drilled (see Figure 3).

STEP 4: Drill four pilot holes in pad, ensuring that the hole is at least 1/4" deeper than the concrete screw being used.

STEP 5: Center basepan over pre-drilled holes and insert concrete screws.

STEP 6: Tighten concrete screws.

NOTE: Do not over-tighten the concrete screws. Doing so can weaken the integrity of the concrete screw and cause it to break.

STEP 7: Finish unit assembly per unit's installation instructions.

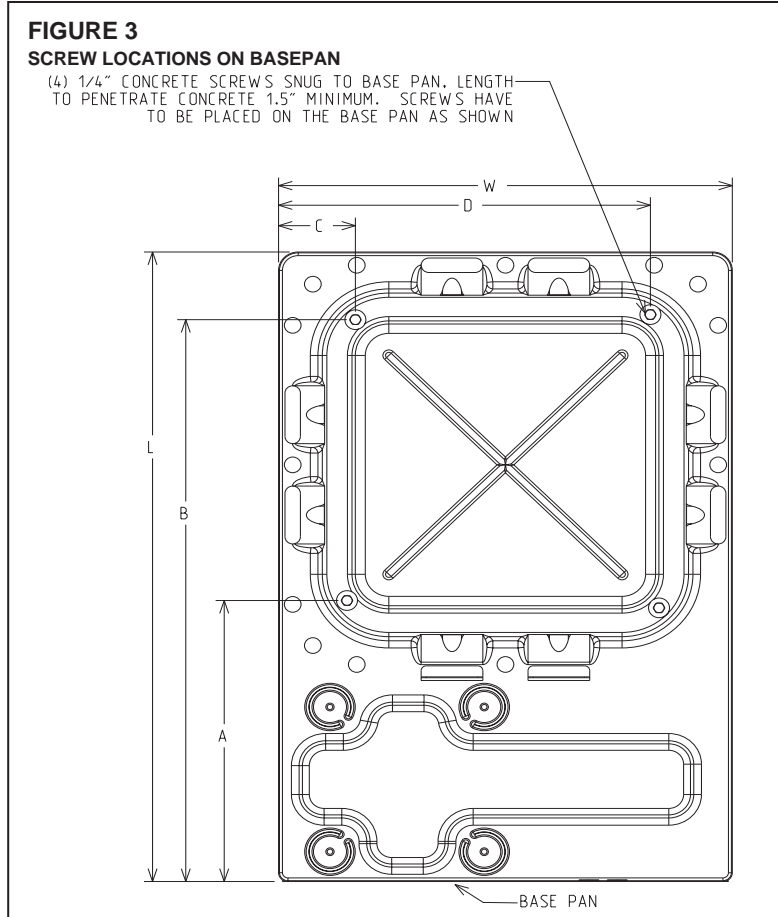

TABLE 3
BASEPAN DIMENSIONS

MODEL NUMBER	L	W	A	B	C	D
(-)PNE/(-)PPC-018	37.625"	25.938"	15"	34"	3.5"	22.5"
(-)PNE/(-)PPC-024/030/036/042/048/060	41.5"	29.813"	15"	38"	3.5"	26.5"

4.0 REFRIGERANT CONNECTIONS

All units are factory charged with Refrigerant 22. All models are supplied with service valves. Keep tube ends sealed until connection is to be made to prevent system contamination.

5.0 REPLACEMENT UNITS

To prevent failure of a new heat pump unit, the existing tubing system must be correctly sized and cleaned or replaced. Care must be exercised that the expansion device is not plugged. For new and replacement units, a liquid line filter drier should be installed and refrigerant tubing should be properly sized. Test the oil for acid. If positive, a liquid line filter drier is mandatory.

6.0 INDOOR COIL

REFER TO INDOOR COIL MANUFACTURER'S INSTALLATION INSTRUCTIONS.

IMPORTANT: The manufacturer is not responsible for the performance and operation of a mismatched system, or for a match listed with another manufacturer's coil.

6.1 LOCATION

Do not install the indoor coil in the return duct system of a gas or oil furnace. Provide a service inlet to the coil for inspection and cleaning. Keep the coil pitched

CAUTION

When coil is installed over a finished ceiling and/or living area, it is recommended that a secondary sheet metal condensate pan be constructed and installed under entire unit. Failure to do so may result in property damage.

toward the drain connection.

7.0 INTERCONNECTING TUBING

7.1 VAPOR AND LIQUID LINES

Keep all lines sealed until connection is made.

Make connections at the indoor coil first.

Refer to Line Size Information in Tables 4 and 5 for correct size and multipliers to be used to determine capacity for various vapor line diameters and lengths of run. The losses due to the lines being exposed to outdoor conditions are not included.

The factory refrigeration charge in the outdoor unit is sufficient for 15 feet of interconnecting lines. The factory refrigeration charge in the outdoor unit is sufficient for the unit and 15 feet of standard size interconnecting liquid and vapor lines. For different lengths, adjust the charge as indicated below.

1/4" ± .3 oz. per foot

5/16" ± .4 oz. per foot

3/8" ± .6 oz. per foot

1/2" ± 1.2 oz. per foot

7.2 MAXIMUM LENGTH OF LINES

The maximum length of interconnecting line is 150 feet. Always use the shortest length possible with a minimum number of bends. Additional compressor oil is not required for any length up to 150 feet.

NOTE: Excessively long refrigerant lines cause loss of equipment capacity.

7.3 OUTDOOR UNIT INSTALLED ABOVE INDOOR COIL

Keep the vertical separation between coils to a minimum. However, the vertical distance can be as great as 120 feet with the condensing unit ABOVE the indoor coil. Use the following guidelines when installing the unit:

1. DO NOT exceed 120 feet maximum vertical separation.
2. DO NOT change the flow check piston sizes if the vertical separation does not exceed the values in Table 5.
3. Flow Check Piston Coil:
 - a. The vertical separation can be greater than the value in Table 5, but no more than 120 feet.
 - b. If the separation height exceeds the Table value, reduce the indoor coil flow check piston by two sizes plus one size for additional 10 feet beyond the Table value.

4. Expansion Valve Coil:
 - a. The vertical separation can be greater than the Table value, but no more than 120 feet.
 - b. No changes are required for expansion valve coils.
5. Capillary Tube Coil:

DO NOT exceed the Table values for vertical separation for capillary tube coils.
6. Always use the smallest liquid line size permitted to minimize the system charge.
7. Table 5 may be used for sizing horizontal runs.

7.4 OUTDOOR UNIT BELOW INDOOR COIL

Keep the vertical separation to a minimum. Use the following guidelines when installing the unit:

1. DO NOT exceed the vertical separations as indicated on Table 5.
2. Always use the smallest liquid line size permitted to minimize system charge.
3. No changes are required for either flow check piston coils or expansions coils.
4. Table 5 may be used for sizing horizontal runs.

7.5 TUBING INSTALLATION

Observe the following when installing correctly sized type “L” refrigerant tubing between the condensing unit and evaporator coil:

- If a portion of the liquid line passes through a hot area where liquid refrigerant can be heated to form vapor, insulating the liquid line is required.
- Use clean, dehydrated, sealed refrigeration grade tubing.
- Always keep tubing sealed until tubing is in place and connections are to be made.
- Blow out the liquid and vapor lines with dry nitrogen before connecting to the outdoor unit and indoor coil. Any debris in the line set will end up plugging the expansion device.
- As an added precaution, a high quality, bi-directional filter drier is recommended to be installed in the liquid line, if not factory installed.
- Do not allow the vapor line and liquid line to be in contact with each other. This causes an undesirable heat transfer resulting in capacity loss and increased power consumption. The vapor line must be insulated.
- If tubing has been cut, make sure ends are deburred while holding in a position to prevent chips from falling into tubing. Burrs such as those caused by tubing cutters can affect performance dramatically, particularly on small liquid line sizes.
- For best operation, keep tubing run as short as possible with a minimum number of elbows or bends.
- Locations where the tubing will be exposed to mechanical damage should be avoided. If it is necessary to use such locations, the copper tubing should be housed to prevent damage.
- If tubing is to be run underground, it must be run in a sealed watertight chase.
- Use care in routing tubing and do not kink or twist. Use a good tubing bender on the vapor line to prevent kinking.
- Route the tubing using temporary hangers, then straighten the tubing and install permanent hangers. Line must be adequately supported.
- The vapor line must be insulated to prevent dripping (sweating) and prevent performance losses. Armaflex and Rubatex are satisfactory insulations for this purpose. Use 1/2” minimum insulation thickness, additional insulation may be required for long runs.
- Check Table 3 for the correct vapor line size. Check Tables 4 and 5 for the correct liquid line size.

TABLE 4
VAPOR LINE LENGTH SIZE AND CAPACITY MULTIPLIER

(-)PNE/(-)PPC		1 1/2 Ton	2 Ton	2 1/2 Ton	3 Ton	3 1/2 Ton	4 Ton	5 Ton
Suction Line Connection Size		3/4" I.D.	3/4" I.D.	3/4" I.D.	7/8" I.D.	7/8" I.D.	7/8" I.D.	7/8" I.D.
Suction Line Run - Feet		5/8 O.D. Optional 3/4 O.D. Standard* 7/8 O.D. Optional			3/4 O.D. Optional 7/8 O.D. Standard* 1-1/8 O.D. Optional		7/8 O.D. Optional 1-1/8 O.D. Standard* 1-3/8 O.D. Optional	
25	Opt.	.99	.99	.98	.99	.99	.99	.99
	Std.	1.00	1.00	1.00	1.00	1.00	1.00	1.00
	Opt.	N/A	1.00	1.00	N/A	1.00	N/A	N/A
50	Opt.	.97	.96	.96	.98	.97	.98	.97
	Std.	.99	.99	.98	.99	.98	.99	.99
	Opt.	N/A	.99	.99	N/A	1.00	N/A	N/A
100	Opt.	.94	.92	.94	.95	.93	.95	.95
	Std.	.96	.96	.96	.96	.96	.98	.98
	Opt.	N/A	.97	.97	N/A	.98	N/A	N/A
150	Opt.	.90	.89	.92	.93	.92	.93	.93
	Std.	.93	.93	.93	.94	.94	.96	.96
	Opt.	N/A	.95	.95	N/A	.96	N/A	N/A

NOTES:

*Standard Line Size

N/A = Problems with oil return to the compressor may result from using this line size.

7.6 TUBING CONNECTIONS

Indoor coils have only a holding charge of dry nitrogen. Keep all tube ends sealed until connections are to be made.

- Use type "L" copper refrigeration tubing. Braze the connections with accepted industry practices.
- Be certain both refrigerant shutoff valves at the outdoor unit are closed.
- Clean the inside of the fittings before brazing.
- Remove the cap and schrader core from service port to protect seals from heat damage.
- Use an appropriate heatsink material around the copper stub and the service valves before applying heat.
- **IMPORTANT:** Do not braze any fitting with the TEV sensing bulb attached.
- Braze the tubing between the outdoor unit and indoor coil. Flow dry nitrogen into a service port and through the tubing while brazing.
- The service valves are not backseating valves. To open the valves, remove the valve cap with an adjustable wrench. Insert a 3/16" or 5/16" hex wrench into the stem. Back out counterclockwise.
- Replace the valve cap finger tight then tighten an additional 1/2 hex flat for a metal-to-metal seal.

7.7 LEAK TESTING

- Pressurize line set and coil through service fittings with dry nitrogen to 150 PSIG maximum. Leak test all joints using liquid detergent. If a leak is found, relieve pressure and repair.

WARNING

Do not use oxygen to purge lines or pressurize system for leak test. Oxygen reacts violently with oil, which can cause an explosion resulting in severe personal injury or death.

TABLE 5
LIQUID LINE SIZE — OUTDOOR UNIT ABOVE OR BELOW INDOOR COIL

R-22 System Capacity Model	Liquid Line Connection Size (Inch I.D.)	Line Size (Inch O.D.) [mm]	Liquid Line Size Outdoor unit Above or Below indoor coil (Heat Pumps Only)					
			Total Equivalent Length - Feet [m]					
			25 [7.62]	50 [15.24]	75 [22.86]	100 [30.48]	125 [38.10]	150 [45.72]
			Maximum Vertical Separation - Feet [m]					
1/2 Ton	5/16"	1/4* [6.35]	21	8	N/A	N/A	N/A	N/A
		5/16 [7.94]	25	27	24	21	17	14
		3/8 [9.53]	25	40	39	38	37	35
2 Ton	5/16"	1/4* [6.35]	16	N/A	N/A	N/A	N/A	N/A
		5/16 [7.94]	25	26	21	15	10	5
		3/8 [9.53]	25	38	36	35	33	31
2 1/2 Ton	5/16"	1/4* [6.35]	0	N/A	N/A	N/A	N/A	N/A
		5/16 [7.94]	25	17	8	0	N/A	N/A
		3/8 [9.53]	25	37	34	31	29	26
3 Ton	5/16"	5/16* [7.94]	25	15	4	N/A	N/A	N/A
		3/8 [9.53]	25	30	26	23	19	16
3 1/2 Ton	5/16"	5/16* [7.94]	25	17	2	N/A	N/A	N/A
		3/8 [9.53]	25	37	32	28	23	18
4 Ton	3/8"	3/8* [9.53]	25	33	27	21	15	9
		1/2 [12.7]	25	43	42	40	39	38
5 Ton	3/8"	3/8* [9.53]	25	25	17	8	0	N/A
		1/2 [12.7]	25	39	37	36	34	32

NOTES:

* Standard line size.
 N/A = Application not recommended.

8.0 DEMAND DEFROST CONTROL

The demand defrost control is a printed circuit board assembly consisting of solid state control devices with electro-mechanical outputs. The demand defrost control monitors the outdoor ambient temperature, outdoor coil temperature, and the compressor run-time to determine when a defrost cycle is required.

Standard Defrost Control (part number 47-21517-16): Found in units with model numbers ending in "BZ".

Enhanced Feature Demand Defrost Control (part number 47-21517-22): Found in units with model numbers ending in "AZ" and units equipped with the field installed Enhanced Compressor Protection Kit (RXPG-A01). Has high and low pressure control inputs with unique pressure switch logic built into the microprocessor to provide compressor and system protection without nuisance lock-outs. Cycles the compressor off for 5 seconds and the beginning and end of the defrost cycle to eliminate the increased compressor noise caused by rapidly changing system pressures when the reversing valve switches. See section 8.7 for diagnostic flash codes for the two diagnostic LED's provided on the control.

8.1 DEFROST INITIATION

A defrost will be initiated when the three conditions below are satisfied:

- 1) The outdoor coil temperature is below 35°F.
- 2) The compressor has operated for at least 34 minutes with the outdoor coil temperature below 35°F.
- 3) The measured difference between the ambient temperature and the outdoor coil temperature is greater than the calculated delta T.

Additionally, a defrost will be initiated if six hours of accumulated compressor run-time has elapsed without a defrost with the outdoor coil temperature below 35°F.

8.2 DEFROST TERMINATION

Once a defrost is initiated, the defrost will continue until fourteen minutes has elapsed or the coil temperature has reached the terminate temperature. The terminate temperature is factory set at 70°F, although the temperature can be changed to 50°F, 60°F, 70°F or 80°F by relocating a jumper on the board.

8.3 TEMPERATURE SENSORS

The coil sensor is clipped to the top tube on the outdoor coil at the point feed by the distribution tubes from the expansion device (short 3/8" dia. tube). The air sensor is located on the defrost control board.

If the ambient sensor fails the defrost control will initiate a defrost every 34 minutes with the coil temperature below 35°F.

If the coil sensor fails the defrost control will not initiate a defrost.

8.4 TEST MODE

The test mode is initiated by shorting the TEST pins. In this mode of operation, the enable temperature is ignored and all timers are sped up by a factor of 240. To initiate a manual defrost, short the TEST pins. Remove the short when the system switches to defrost mode. The defrost will terminate on time (14 minutes) or when the termination temperature has been achieved. Short TEST pins again to terminate the defrost immediately.

8.5 TROUBLE SHOOTING DEMAND DEFROST

Set the indoor thermostat select switch to heat and thermostat lever to a call for heat.

Jumper the "test pins" to put the unit into defrost. If the unit goes into defrost and comes back out of defrost, the indication is that the control is working properly.

If the unit did not go into defrost using the test pins, check to ensure that 24V is being supplied to the control board. If 24V is present then replace the control.

8.6 HIGH/LOW PRESSURE CONTROL MONITORING - ENHANCED DEFROST CONTROL ONLY (Units with Model Numbers Ending with "AZ")

Status of high and low pressure controls is monitored by the enhanced feature demand defrost control and the following actions are taken.

High Pressure Control – Provides active protection in both cooling and heating modes at all outdoor ambient temperatures. The high pressure control is an automatic reset type and opens at approximately 440 psig and closes at approximately 270 psig. The compressor and fan motor will stop when the high pressure control opens and will start again if the high side pressure drops to approximately 270 psig when the automatic reset high pressure control resets. If the high pressure control opens 3 times within a particular call for heating or cooling operation, the defrost control will lock out compressor and outdoor fan operation.

Low Pressure Control – Provides active protection in both heating and cooling modes at all outdoor ambient temperatures. The low pressure control is an automatic reset type and opens at approximately 7 psig and closes at approximately 22 psig. Operation is slightly different between cooling and heating modes.

Cooling Mode: the compressor and fan motor will stop when the low pressure control opens and will start again when the low side pressure rises to approximately 22 psig and the low pressure control automatically resets. If the low pressure switch open 3 times within a particular call for cooling operation, the defrost control will lock out compressor and outdoor fan operation.

Heating Mode: The compressor and fan motor will stop when the low pressure control opens and will start again when the low side pressure rises to approximately 22 psig and the low pressure control automatically resets. If the low pressure switch trips 3 times within 120 minutes of operation during a particular call for heating operation, the defrost control will lock out compressor and outdoor fan operation. If the lock-out due to low pressure occurs at an outdoor ambient temperature below 5°F, the defrost control will automatically exit the lock-out mode when the outdoor ambient temperature rises to 5°F. This feature is necessary since the low pressure control could possibly have opened due to the outdoor ambient being very low rather than an actual system fault.

Exiting Lock-Out Mode: To exit the lock-out mode, remove 24 volts to the defrost control by removing power to the indoor air-handler/furnace or by shorting the two defrost control test pins together.

8.7 ENHANCED FEATURE DEFROST CONTROL DIAGNOSTIC CODES

LED 1	LED 2	Control Board Status
OFF	OFF	No Power
ON	ON	Coil Sensor Failure
OFF	ON	Ambient Sensor Failure
FLASH	FLASH	Normal
OFF	FLASH	Low Pressure Lockout (short test pins to reset)
FLASH	OFF	High Pressure Lockout (short test pins to reset)
ON	FLASH	Low Pressure Control Open
FLASH	ON	High Pressure Control Open
Alternate Flashing		5 Minute Time Delay

9.0 EVACUATION PROCEDURE

The life and efficiency of the equipment is dependent upon the thoroughness exercised by the technician when evacuating air and moisture from the system.

Air in the system causes high condensing temperatures and pressure, resulting in increased power input and non-verifiable performance.

Moisture chemically reacts with the refrigerant and oil to form corrosive hydrofluoric and hydrochloric acids. These attack motor windings and parts, causing breakdown.

After the system has been leak checked and proven sealed, connect the vacuum pump and evacuate system to 500 microns. The vacuum pump must be connected to both the high and low sides of the system through adequate connections. Use the largest size connections available since restrictive service connections may lead to false readings because of pressure drop through the fittings.

IMPORTANT: Compressors (especially scroll type) should never be used to evacuate the heat pump system because internal electrical arcing may result in a damaged or failed compressor.

10.0 START UP AND PERFORMANCE

Even though the unit is factory-charged with Refrigerant-22 (R-22), the charge must be checked to the charge table on the service panel and adjusted, if required. (See Table 1.) Allow the unit to run for a minimum of five minutes. Before analyzing charge, see the instructions on the unit service panel rating plate for marking the total charge.

11.0 CHECKING AIRFLOW

The air distribution system has the greatest effect on airflow. The duct system is totally controlled by the contractor. For this reason, the contractor should use only industry-recognized procedures.

Heat pump systems require a specified airflow. Each ton of cooling requires between 350 and 450 cubic feet of air per minute (CFM), or 400 CFM nominally.

Duct design and construction should be carefully done. System performance can be lowered dramatically through bad planning or workmanship.

Air supply diffusers must be selected and located carefully. They must be sized and positioned to deliver treated air along the perimeter of the space. If they are too small for their intended airflow, they become noisy. If they are not located properly, they cause drafts. Return air grilles must be properly sized to carry air back to the blower. If they are too small, they also cause noise.

The installers should balance the air distribution system to ensure proper quiet airflow to all rooms in the home. This ensures a comfortable living space.

An air velocity meter or airflow hood can give a reading of the system CFM's.

12.0 CHECKING REFRIGERANT CHARGE

Charge for all systems should be checked against the Charging Chart inside the access panel cover.

IMPORTANT: Do not operate the compressor without charge in system.

Addition of R-22 will raise pressures (vapor, liquid and discharge).

If adding R-22 raises both vapor pressure and temperature, the unit is overcharged.

IMPORTANT: Use industry-approved charging methods to ensure proper system charge.

12.1 CHARGING BY LIQUID PRESSURE

Liquid pressure method is used for charging systems in the cooling and heating mode. The service port on the liquid service valve (small valve) and suction (large valve) is used for this purpose.

Verify that the outdoor unit is running and the indoor air mover is delivering the maximum airflow for this system size. Read and record the outdoor ambient temperature. Read and record the liquid and suction pressures at the ports on the liquid and suction valves. If refrigerant lines are sized using the nameplate charge, the correct liquid pressure is found at the intersection of the suction pressure and the outdoor ambient.

1. Remove refrigerant charge if the liquid pressure is above the chart value.
2. Add refrigerant charge if the liquid pressure is below the chart value.

12.2 CHARGING BY WEIGHT

For a new installation, evacuation of interconnecting tubing and indoor coil is adequate; otherwise, evacuate the entire system. Use the factory charge shown in Tables 1 through 5 of these instructions or unit data plate. Note that charge value includes charge required for 15 ft. of standard size interconnecting liquid line. Calculate actual charge required with installed liquid line size and length using:

1/4" O.D. = .3 oz./ft.

5/16" O.D. = .4 oz./ft.

3/8" O.D. = .6 oz./ft.

1/2" O.D. = 1.2 oz./ft.

With an accurate scale (+/- 1 oz.) or volumetric charging device, adjust charge difference between that shown on the unit data plate and that calculated for the new system installation. If the entire system has been evacuated, add the total calculated charge.

12.3 FINAL LEAK TESTING

After the unit has been properly evacuated and charged, a halogen leak detector should be used to detect leaks in the system. All piping within the condensing unit, evaporator, and interconnecting tubing should be checked for leaks. If a leak is detected, the refrigerant should be recovered before repairing the leak. The Clean Air Act prohibits releasing refrigerant into the atmosphere.

13.0 ELECTRICAL WIRING

WARNING

Turn off electric power at the fuse box or service panel before making any electrical connections.

Also, the ground connection must be completed before making line voltage connections. Failure to do so can result in electrical shock, severe personal injury or death.

CAUTION

Single-pole contactors are used on all standard single-phase units up through 5 tons. Caution must be exercised when servicing as only one leg of the power supply is broken with the contactor. Two pole contactors are used on some three phase units.

Field wiring must comply with the National Electric Code (C.E.C. in Canada) and any applicable local code.

13.1 POWER WIRING

It is important that proper electrical power from a commercial utility is available at the condensing unit contactor. Voltage ranges for operation are shown in Table 6.

Install a branch circuit disconnect within sight of the unit and of adequate size to handle the starting current (see Table 1).

Power wiring must be run in a rain-tight conduit. Conduit must be run through the connector panel below the access cover (see Figure 1) and attached to the bottom of the control box.

Connect power wiring to contactor located in outdoor condensing unit electrical box. (See wiring diagram attached to unit access panel.)

Check all electrical connections, including factory wiring within the unit and make sure all connections are tight.

DO NOT connect aluminum field wire to the contactor terminals.

TABLE 6
VOLTAGE RANGES (60 HZ)

Nameplate Voltage	Operating Voltage Range at Copeland Maximum Load Design Conditions for Compressors
208/230 (1 Phase)	197 - 253
208/230 (3 Phase)	187 - 253
460	414 - 506
575	517 - 633

13.2 GROUNDING

A grounding lug is provided near the contactor for a ground wire.

⚠ WARNING

The unit must be permanently grounded. Failure to do so can cause electrical shock resulting in severe personal injury or death.

13.3 CONTROL WIRING

(See Figure 4)

If the low voltage control wiring is run in conduit with the power supply, Class I insulation is required. Class II insulation is required if run separate. Low voltage wiring may be run through the insulated bushing provided in the 7/8 hole in the base panel, up to and attached to the pigtails from the bottom of the control box. Conduit can be run to the base panel if desired by removing the insulated bushing.

A thermostat and a 24 volt, 40 VA minimum transformer are required for the control circuit of the condensing unit. The furnace or the air handler transformer may be used if sufficient. See the wiring diagram for reference. Use Table 6 to size the 24 volt control wiring.

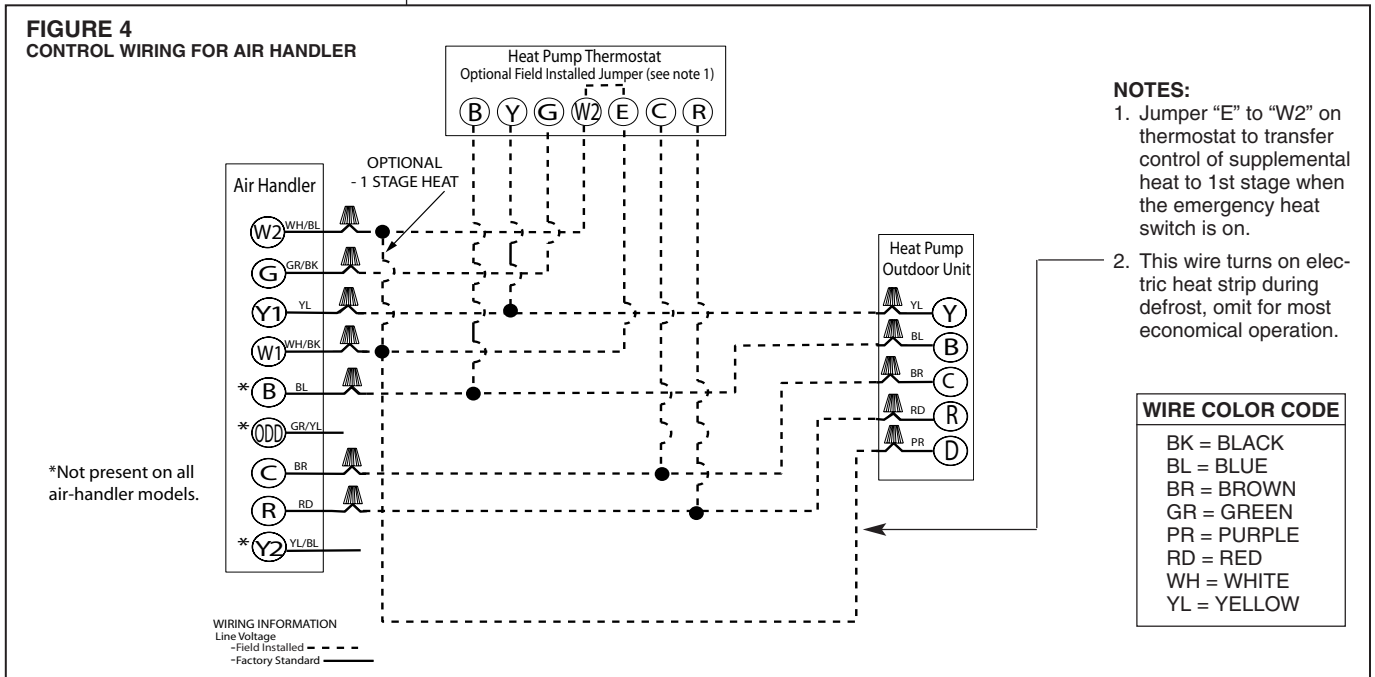

TABLE 7

FIELD WIRE SIZE FOR 24 VOLT THERMOSTAT CIRCUITS

Thermostat Load - Amps	SOLID COPPER WIRE - AWG.					
	50	100	150	200	250	300
3.0	16	14	12	10	10	10
2.5	16	14	12	12	10	10
2.0	18	16	14	12	12	10
	50	100	150	200	250	300

Length of Run - Feet (1)

(1) Wire length equals twice the run distance.

NOTE: Do not use control wiring smaller than No. 18 AWG between thermostat and outdoor unit.

14.0 FIELD INSTALLED ACCESSORIES

14.1 COMPRESSOR CRANKCASE HEATER (CCH)

While scroll compressors usually do not require crankcase heaters, there are instances when a heater should be added. Refrigerant migration during the off cycle can result in a noisy start up. Add a crankcase heater to minimize refrigeration migration, and to help eliminate any start up noise or bearing "wash out."

NOTE: The installation of a crankcase heater is recommended if the system charge exceeds the values in Table 8. All 3-phase models come standard with a crankcase heater factory installed.

TABLE 8
MAXIMUM SYSTEM CHARGE VALUES: (-)PNE SINGLE PHASE, (-)PPC

Model Size*	Compressor Model Number	Charge Limit Without Crankcase Heater*
-018	ZR16K4-PFV	7.2 lbs.
-024	ZR22K3-PFV	9.6 lbs.
-030	ZR28K3-PFV	9.6 lbs.
-036	ZR34K3-PFV	9.6 lbs.
-042	ZR40K3-PFV	9.6 lbs.
-048	ZR45K3-PFV	9.6 lbs.

*-060 comes with the crankcase heater factory-installed.

All heaters are located on the lower half of the compressor shell. Its purpose is to drive refrigerant from the compressor shell during long off cycles, thus preventing damage to the compressor during start-up.

At initial start-up or after extended shutdown periods, make sure the heater is energized for at least 12 hours before the compressor is started. (Disconnect switch on and wall thermostat off.)

14.2 HARD START COMPONENTS

Start components are not usually required with the scroll compressors used in (-)PNE heat pumps, but are available for special cases and where start components are desirable to reduce light dimming.

NOTE: Hard start components are standard on (-)PNE/(-)PPC****AZ models.

14.3 TIME DELAY CONTROL (TDC)

The time delay (TDC) is in the low voltage control circuit. When the compressor shuts off due to a power failure or thermostat operation, this control keeps it off at least 5 minutes which allows the system pressure to equalize, thus not damaging the compressor or blowing fuses on start-up.

14.4 LOW AMBIENT CONTROL (LAC)

This component senses compressor head pressure and shuts the heat pump fan off when the head pressure drops to approximately 150 PSIG. This allows the unit to build a sufficient head pressure at lower ambient in order to maintain system balance and obtain improved capacity. Low ambient control should be used on all equipment operated below 65°F ambient.

14.5 HIGH PRESSURE CONTROL (HPC)

These controls keep the compressor from operating in pressure ranges which can cause damage to the compressor. The HPC is in the low voltage control circuit.

High pressure control (HPC) is a manual reset which opens near 440 PSIG. Do not reset arbitrarily without first determining what caused it to trip.

NOTE: High pressure control is standard on (-)PNE/(-)PPC****AZ models.

14.6 ENHANCED COMPRESSOR PROTECTION KIT – RXPB-A01

This kit includes an enhanced defrost control, auto-reset high pressure control (HPC), and an auto-reset low pressure control (LPC) that will convert the control system of a (-)PNE-****BZ to the enhanced control system of a (-)PNE-****AZ. This kit provides compressor protection under abnormally high head pressure conditions (outdoor fan failure, restriction, dirty coil, etc.) or abnormally low suction pressure conditions (restriction, TEV failure, loss of charge, indoor blower failure, etc.) while eliminating nuisance tripping sometimes experienced with conventional control systems.

NOTE: This kit is not necessary on (-)PNE/(-)PPC****AZ models since they come standard from the factory with this control system.

15.0 TROUBLE SHOOTING

In diagnosing common faults in the heat pump system, develop a logical thought pattern as used by experienced technicians. The charts which follow are not intended to be an answer to all problems but only to guide the technician's thinking. Through a series of yes and no answers, follow the logical path to a likely conclusion.

A novice technician should use these charts like a road map. Remember that the chart should clarify a logical path to the problem's solution.

15.1 ELECTRICAL CHECKS FLOW CHART

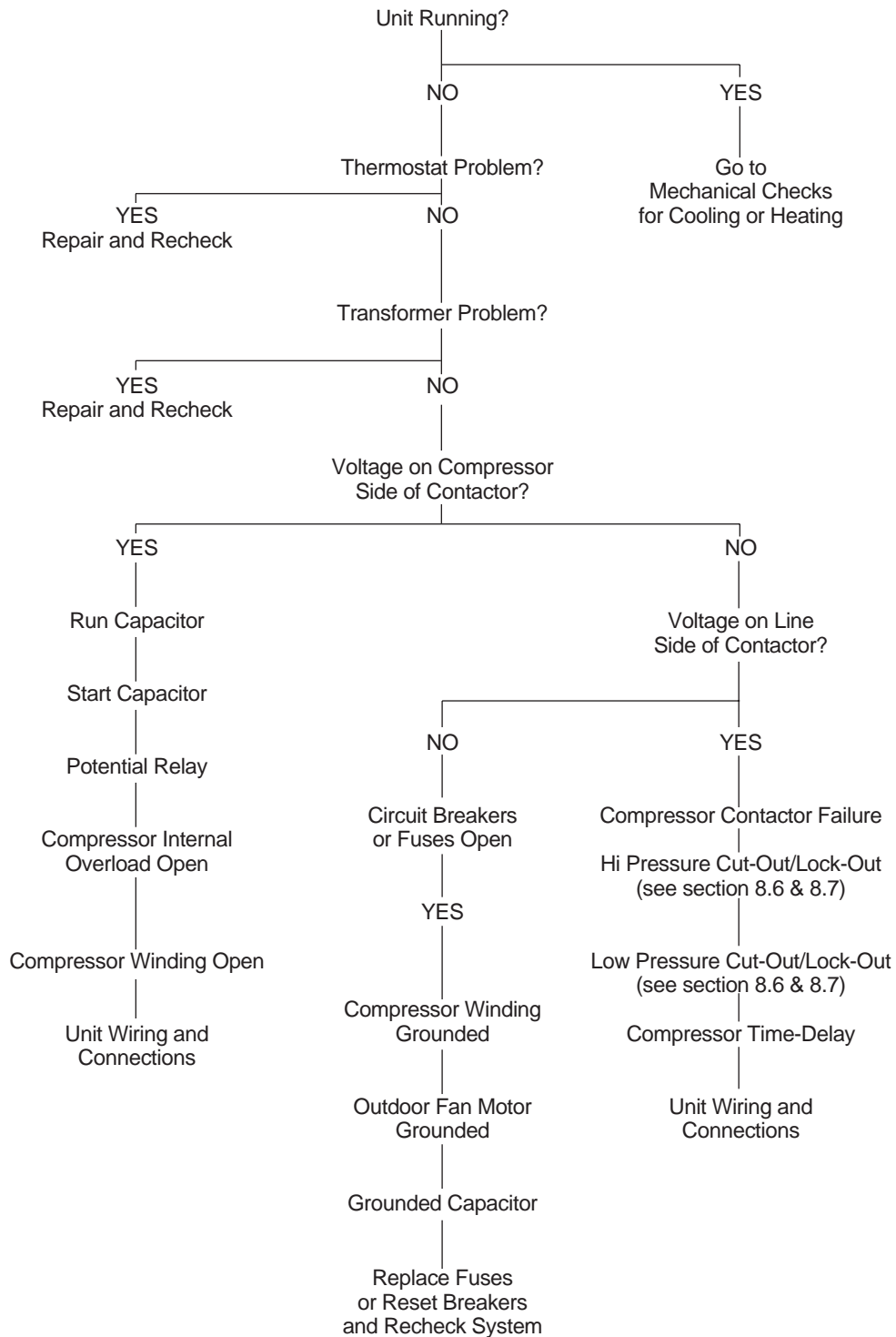

15.2 COOLING MECHANICAL CHECKS FLOW CHART

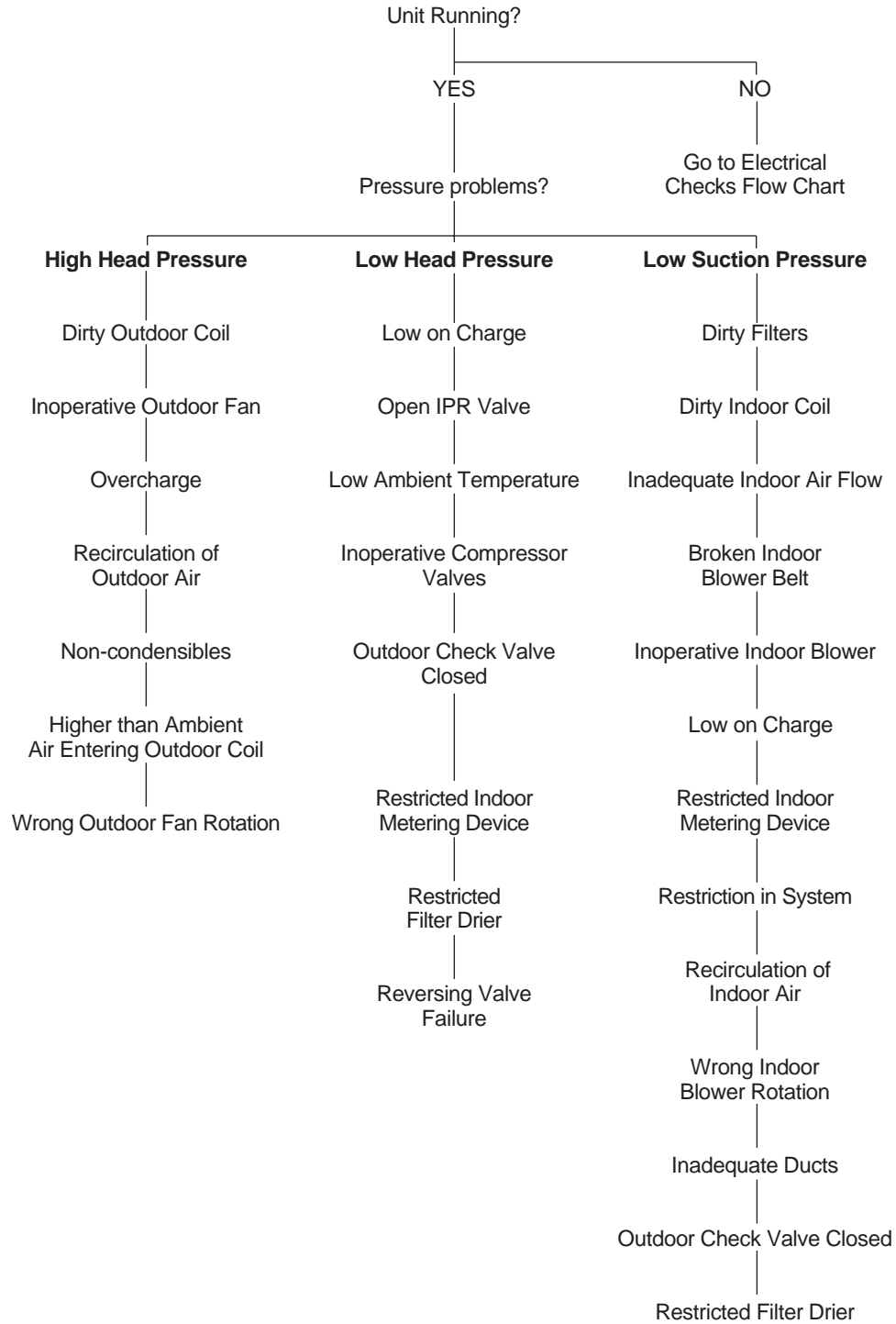

15.3 HEATING MECHANICAL CHECKS FLOW CHART

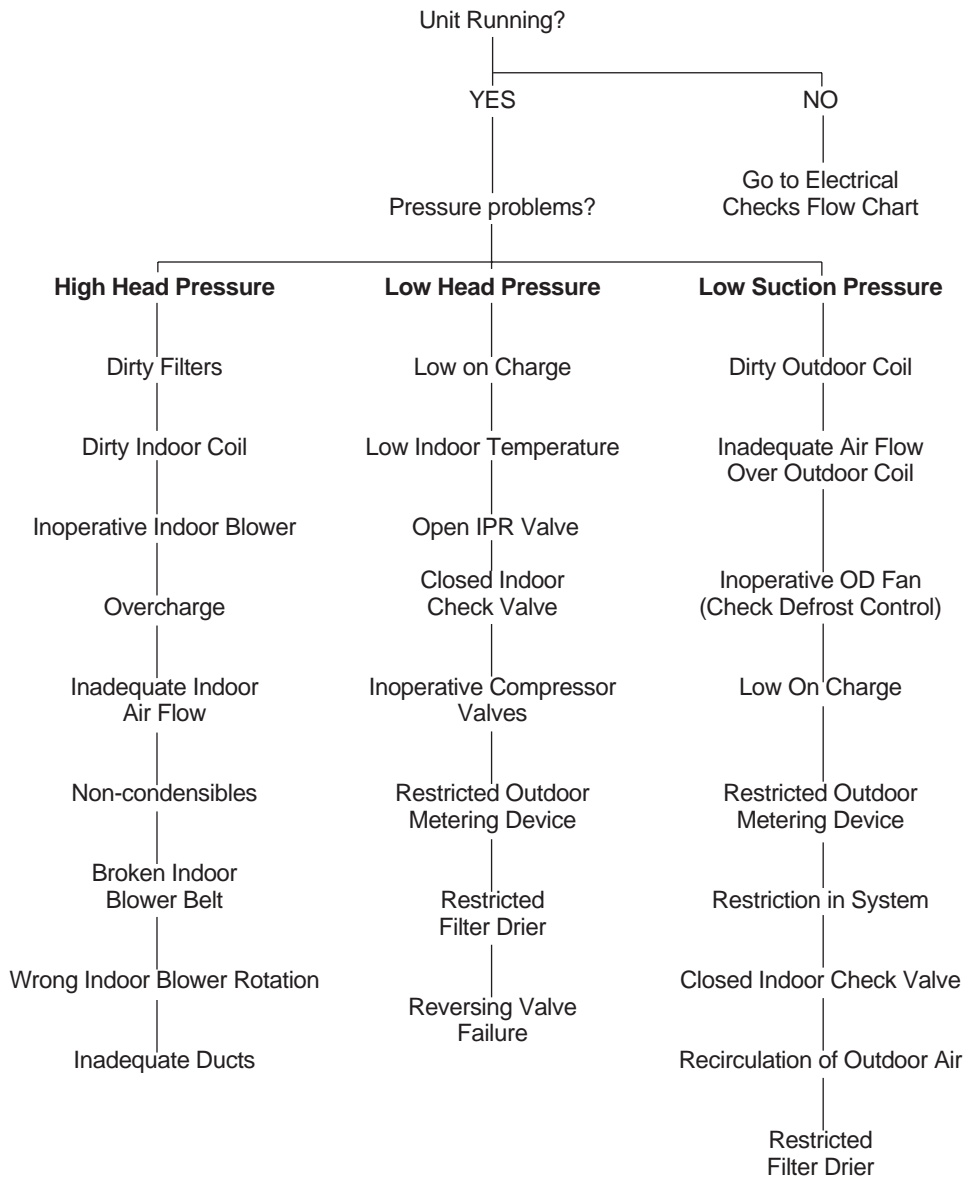

15.4 DEFROST MECHANICAL CHECKS FLOW CHART

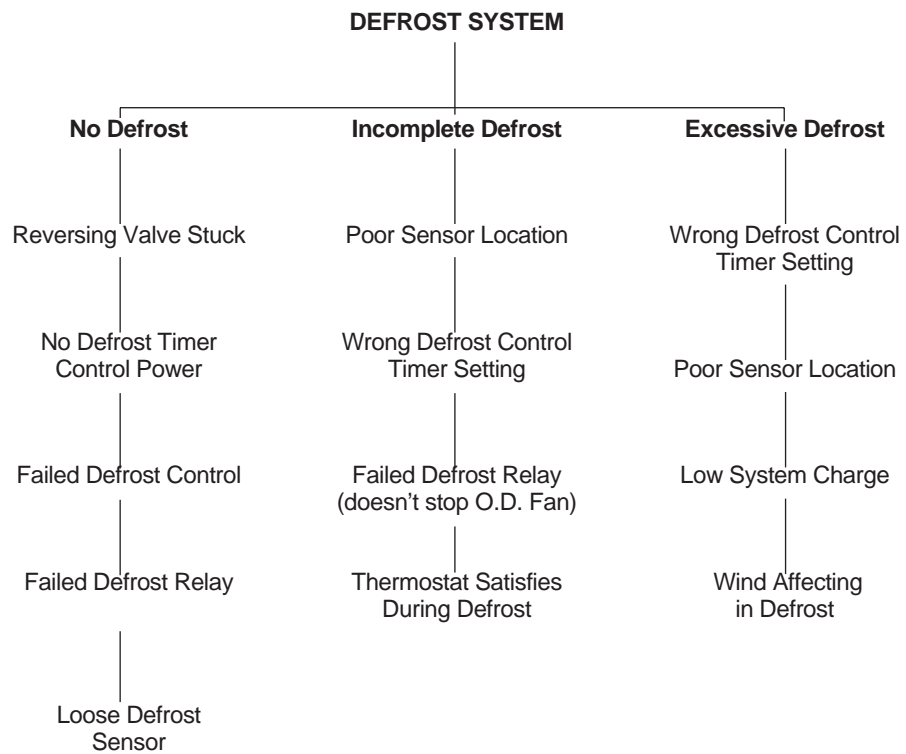

TABLE 9
TEMPERATURE PRESSURE CHART

TEMP (Deg. F)	R-22 PSIG
-150	*29.4
-140	*29.1
-130	*28.5
-120	*27.7
-110	*26.6
-100	*25.1
-90	*23.0
-80	*20.2
-70	16.6
-60	*11.9
-50	*6.1
-40	0.6
-35	2.6
-30	4.9
-25	7.5
-20	10.2
-15	13.2
-10	16.5
-5	20.1
0	24.0
5	28.3
10	32.8
15	37.8
20	43.1
25	48.8
30	54.9
35	61.5
40	68.5
45	76.1
50	84.1
55	92.6
60	101.6
65	111.3
70	121.4
75	132.2
80	143.7
85	155.7
90	168.4
95	181.8
100	196.0
105	210.8
110	226.4
115	242.8
120	260.0
125	278.1
130	297.0
135	316.7
140	337.4
145	359.1
150	381.7

15.5 SUBCOOLING CALCULATION

1. Measure the liquid pressure at the liquid line service valve.
2. Convert the liquid line pressure to saturated temperature. See Table 9.
3. Measure the liquid line temperature at the liquid line service valve.
4. Compare the liquid line temperature to the saturated temperature.
5. The difference between saturated temperature and liquid line temperature is the subcooling. Subcooling normal range 9° to 12°.

TABLE 10
HEAT PUMP SYSTEM TROUBLESHOOTING TIPS

HEAT PUMP SYSTEM TROUBLESHOOTING TIPS					
SYSTEM PROBLEM	INDICATORS				
	DISCHARGE PRESSURE	SUCTION PRESSURE	SUPERHEAT	SUBCOOLING	COMPRESSOR AMPS
Overcharge	High	High	Low	High	High
Undercharge	Low	Low	High	Low	Low
Liquid Restriction (Drier)	Low	Low	High	High	Low
Low Evaporator Airflow	Low	Low	Low	Low	Low
Dirty Heat Pump	High	High	Low	Low	High
Low Outside Ambient Temperature	Low	Low	High	High	Low
Inefficient Compressor	Low	High	High	High	Low
TEV Feeler Bulb Charge Lost	Low	Low	High	High	Low
Poorly Insulated Sensing Bulb	High	High	Low	Low	High

15.6 GENERAL TROUBLE SHOOTING CHART

▲ WARNING

Disconnect all power to unit before servicing. Contactor may break only one side. Failure to shut off power can cause electrical shock resulting in personal injury or death.

SYMPTOM	POSSIBLE CAUSE	REMEDY
Unit will not run	<ul style="list-style-type: none"> • Power off or loose electrical connection • Thermostat out of calibration-set too high • Defective contactor • Blown fuses / tripped breaker • Transformer defective • High pressure control open (if provided) or defrost control lockout due to 3 high pressure control trips. * Low pressure control open (if provided) or defrost control lockout due to 3 low pressure control trips. 	<ul style="list-style-type: none"> • Check for correct voltage at contactor in condensing unit • Reset • Check for 24 volts at contactor coil - replace if contacts are open • Replace fuses / reset breaker • Check wiring-replace transformer • The high pressure control opens at 440 PSIG. Check for blocked coils, failed fan or blower motor, wiring issues, or defective high pressure control. See section 8.6 to reset defrost control. • The low pressure control opens at 7 PSIG. Check for low charge, blocked coils, wiring issues, or defective low pressure control. See section 8.6 to reset defrost control.
Outdoor fan runs, compressor doesn't	<ul style="list-style-type: none"> • Run or start capacitor defective • Start relay defective • Loose connection • Compressor stuck, grounded or open motor winding, open internal overload. • Low voltage condition 	<ul style="list-style-type: none"> • Replace • Replace • Check for correct voltage at compressor - check & tighten all connections • Wait at least 2 hours for overload to reset. If still open, replace the compressor. • Add start kit components
Insufficient cooling	<ul style="list-style-type: none"> • Improperly sized unit • Improper indoor airflow • Incorrect refrigerant charge • Air, non-condensibles or moisture in system 	<ul style="list-style-type: none"> • Recalculate load • Check - should be approximately 400 CFM per ton. • Charge per procedure attached to unit service panel • Recover refrigerant, evacuate & recharge, add filter drier
Compressor short cycles	<ul style="list-style-type: none"> • Incorrect voltage • Defective overload protector • Refrigerant undercharge 	<ul style="list-style-type: none"> • At compressor terminals, voltage must be $\pm 10\%$ of nameplate marking when unit is operating. • Replace - check for correct voltage • Add refrigerant
Registers sweat	<ul style="list-style-type: none"> • Low indoor airflow 	<ul style="list-style-type: none"> • Increase speed of blower or reduce restriction - replace air filter
High head-low vapor pressures	<ul style="list-style-type: none"> • Restriction in liquid line, expansion device or filter drier • Flowcheck piston size too small • Incorrect capillary tubes 	<ul style="list-style-type: none"> • Remove or replace defective component • Change to correct size piston • Change coil assembly
High head-high or normal vapor pressure - Cooling mode	<ul style="list-style-type: none"> • Dirty outdoor coil • Refrigerant overcharge • Outdoor fan not running • Air or non-condensibles in system 	<ul style="list-style-type: none"> • Clean coil • Correct system charge • Repair or replace • Recover refrigerant, evacuate & recharge
Low head-high vapor pressures	<ul style="list-style-type: none"> • Flowcheck piston size too large • Defective Compressor valves • Incorrect capillary tubes 	<ul style="list-style-type: none"> • Change to correct size piston • Replace compressor • Replace coil assembly
Low vapor pressure - cool compressor -iced indoor coil	<ul style="list-style-type: none"> • Low indoor airflow • Operating below 65°F outdoors • Moisture in system • Low refrigerant charge 	<ul style="list-style-type: none"> • Increase speed of blower or reduce restriction - replace air filter • Add Low Ambient Kit • Recover refrigerant - evacuate & recharge - add filter drier • Repair leak, evacuate & recharge
High vapor pressure	<ul style="list-style-type: none"> • Excessive load • Defective compressor 	<ul style="list-style-type: none"> • Recheck load calculation • Replace
Fluctuating head & vapor pressures	<ul style="list-style-type: none"> • TEV hunting • Air or non-condensibles in system 	<ul style="list-style-type: none"> • Check TEV bulb clamp - check air distribution on coil - replace TEV • Recover refrigerant, evacuate & recharge
Gurgle or pulsing noise at expansion device or liquid line	<ul style="list-style-type: none"> • Air or non-condensibles in system 	<ul style="list-style-type: none"> • Recover refrigerant, evacuate & recharge

15.7 SERVICE ANALYZER CHARTS

COMPRESSOR OVERHEATING		
SYMPTOMS	POSSIBLE CAUSE	CHECK/REMEDIES
High superheat	Low charge	Check system charge
	Faulty metering device	Restricted cap tube, TEV (TXV)
		Power element superheat adjustment
		Foreign matter stopping flow
	High internal load	Hot air (attic) entering return
		Heat source on; mis-wired or faulty control
	Restriction in liquid line	Drier plugged
		Line kinked
	Low head pressure	Low charge
		Operating in low ambient temperatures
Suction or liquid line subjected to high heat source	Hot attic	
	Hot water line	
Low voltage	Loose wire connections	Check wiring
	Dirty or pitted compressor contactor contacts	Replace contactor
	Power company problem, transformer	Have problem corrected before diagnosis continues
	Undersized wire feeding unit	Correct and complete diagnosis
High voltage	Power company problem	Have problem corrected
High head pressure	Overcharge	Check system charge
	Dirty heat pump coil	Clean coil
	Faulty or wrong size heat pump fan motor	Replace fan motor
	Faulty fan blade or wrong rotation	Replace fan blade
		Replace with correct rotation motor
	Recirculation of air	Correct installation
	Additional Heat Source	Check for dryer vent near unit
		Check for recirculation from other equipment
	Non-condensibles	Recover refrigerant, Evacuate and recharge system
Equipment not matched	Correct mis-match	
Short cycling of compressor	Faulty pressure control	Replace pressure control
	Loose wiring	Check unit wiring
	Thermostat	Located in supply air stream
		Differential setting too close
		Customer misuse
	TEV	Internal foreign matter
		Power element failure
		Valve too small
		Distributor tube/tubes restricted
	Capillary tube	Restricted with foreign matter
Kinked		
I.D. reduced from previous compressor failure		

SYMPTOMS	POSSIBLE CAUSE	CHECK OR REMEDIES
Short cycling of compressor (cont.)	Low charge	Check system charge
	Low evaporator air flow	Dirty coil
		Dirty filter
		Duct too small or restricted
Faulty run capacitor	Faulty run capacitor	Replace
	Faulty internal overload	Replace compressor
Faulty Compressor Valves	Fast equalization/ Low pressure difference	Replace compressor and examine system to locate reason
<i>ELECTRICAL</i>		
SYMPTOMS	POSSIBLE CAUSE	CHECK OR REMEDIES
Voltage present on load side of compressor contactor and compressor won't run	Compressor start components	Check start capacitor
		Check potential relay
	Run capacitor	Check with ohmmeter
	Internal overload	Allow time to reset
Voltage present on line side of pressor contactor only	Thermostat	Check for control voltage to com- contactor coil
		Compressor control circuit
	Low pressure switch open	
	Ambient thermostat	
	Solid state protection control or internal thermal sensors	
	Compressor timed off/on control or interlock	
Defrost control locked out due to 3 high or low pressure control trips. See sections 8.6 & 8.7.		
No voltage on line side of compressor contactor	Blown fuses or tripped circuit breaker	Check for short in wiring or unit
	Improper wiring	Re-check wiring diagram
Improper voltage	High voltage	Wrong unit
		Power supply problem
	Low voltage	Wrong unit
		Power supply problem
		Wiring undersized
Loose connections		
Single Phasing (3 phase)	Check incoming power and fusing	
<i>CONTAMINATION</i>		
SYMPTOMS	POSSIBLE CAUSE	CHECK OR REMEDIES
Moisture	Poor evacuation on installation or during service	In each case, the cure is the same. Recover refrigerant. Add filter drier, evacuate and re-charge
High head pressure	Non-condensibles air	
Unusual head and suction readings	Wrong refrigerant	
Foreign Matter-copper filings	Copper tubing cuttings	
Copper oxide	Dirty copper piping	
Welding scale	Nitrogen not used	
Soldering flux	Adding flux before seating copper part way	
Excess soft solder	Wrong solder material	

LOSS OF LUBRICATION		
SYMPTOMS	POSSIBLE CAUSE	CHECK OR REMEDIES
Compressor failures	Line tubing too long	Add oil to the recommended level
	Line tubing too large	Reduce pipe size to improve oil return
Low suction pressure	Low charge	Check system charge
	Refrigerant leaks	Repair and recharge
Cold, Noisy compressor - Slugging	Dilution of Oil with Refrigerant	Observe piping guidelines
Noisy compressor	Migration	Check crankcase heater
Cold, sweating compressor	Flooding	Check system charge
Low Load	Reduced air flow	Dirty filter
		Dirty coil
		Wrong duct size
		Restricted duct
Short cycling of compressor	Thermostat setting	Advise customer
	Faulty pressure control	Replace control
	Loose wiring	Check all control wires
	Thermostat	In supply air stream, out of calibration, Customer misuse
FLOODED STARTS		
SYMPTOMS	POSSIBLE CAUSES	CHECK OR REMEDIES
Liquid in the compressor shell	Faulty or missing crankcase heater	Replace crankcase heater
Too much liquid in system	Incorrect piping	Check Piping guidelines
	Overcharge	Check and adjust charge
SLUGGING		
SYMPTOMS	POSSIBLE CAUSES	CHECK OR REMEDIES
On start up	Incorrect piping	Review pipe size guidelines
TEV hunting when running	Oversized TEV	Check TEV application
FLOODING		
SYMPTOMS	POSSIBLE CAUSES	CHECK OR REMEDIES
Poor system control using a TEV	Loose sensing bulb	Secure the bulb and insulate
	Bulb in wrong location	Relocate bulb
	Wrong size TEV	Use correct replacement
	Improper superheat setting	Adjust, if possible; Replace, if not
Poor system control using capillary tubes	Overcharge	Check system charge
	High head pressures	Dirty heat pump
		Restricted air flow
		Recirculation of air
	Evaporator air flow too low	Adjust air flow to 400 CFM/Ton

THERMOSTATIC EXPANSION VALVES

SYMPTOMS	POSSIBLE CAUSE	CHECK OR REMEDIES	
High Superheat, Low Suction Pressure	Moisture freezing and blocking valve	Recover charge, install filter-drier, evacuate system, recharge	
	Dirt or foreign material blocking valve	Recover charge, install filter-drier, evacuate system, recharge	
	Low refrigerant charge	Correct the charge	
	Vapor bubbles in liquid line	Remove restriction in liquid line Correct the refrigerant charge	
		Remove non-condensable gases	
		Size liquid line correctly	
	Misapplication of internally equalized valve	Use correct TEV	
	Plugged external equalizer line	Remove external equalizer line restriction	
	Undersized TEV	Replace with correct valve	
	Loss of charge from power head sensing bulb	Replace power head or complete TEV	
	Charge migration from sensing bulb to power head (Warm power head with warm, wet cloth. Does valve operate correctly now?)	Ensure TEV is warmer than sensing bulb	
Improper superheat adjustment (Only applicable to TEV with adjustable superheat settings)	Adjust superheat setting counter-clockwise		
Valve feeds too much refrigerant, with low superheat and higher than normal suction pressure	Moisture causing valve to stick open.	Recover refrigerant, replace filter-drier, evacuate system and then non-recharge	
	Dirt or foreign material causing valve to stick open	Recover refrigerant, replace filter-drier, evacuate system and recharge	
	TEV seat leak (A gurgling or hissing sound is heard AT THE TEV during the off cycle, if this is the cause.) NOT APPLICABLE TO BLEED PORT VALVES.	Replace the TEV	
	Oversized TEV	Install correct TEV	
	Incorrect sensing bulb location	Install bulb with two mounting straps, in 2:00 or 4:00 position on suction line, with insulation	
	Low superheat adjustment (only applicable to TEV with adjustable superheat setting)	Turn superheat adjustment clockwise	
	Incorrectly installed, or restricted external equalizer line	Remove restriction, or relocate external equalizer	
Compressor flood back upon start up	Refrigerant drainage from flooded evaporator	Install trap riser to the top of the evaporator coil	
	Compressor in cold location	Install crankcase heater on compressor	
	Any of the causes listed under Symptoms of Problem #2	Any of the solutions listed under Solutions of Problem #2	

THERMOSTATIC EXPANSION VALVES

SYMPTOMS	POSSIBLE CAUSE	CHECK OR REMEDIES
Superheat is low to normal with low suction pressure	Unequal evaporator circuit loading	Ensure air flow is equally distributed through evaporator
		Ensure proper piston is inserted into RCBA or RCHA evaporator coil distributor
		Check for blocked distributor tubes
	Low load or airflow entering evaporator coil	Ensure blower is moving proper air CFM
		Remove/Correct any air flow restriction
Superheat and suction pressure fluctuate (valve is hunting)	Expansion valve is oversized	Install correct TEV
	Sensing bulb is affected by liquid refrigerant or refrigerant oil flowing through suction line	Relocate sensing bulb in another position around the circumference of the suction line
	Unequal refrigerant flow through evaporator circuits	Ensure proper distributor piston is inserted in RCBA or RCHA coil
		Ensure sensing bulb is located properly
		Check for blocked distributor tubes
	Improper superheat adjustment (only possible with TEV having superheat adjustment)	Replace TEV or adjust superheat
Moisture freezing and partially blocking TEV	Recover refrigerant, change filter-drier, evacuate system and recharge	
Valve does not regulate at all	External equalizer line not connected or line plugged	Connect equalizer line in proper location, or remove any blockage
	Sensing bulb lost its operating charge	Replace TEV
	Valve body damaged during soldering or by improper installation	Replace TEV

16.0 WIRING DIAGRAMS

FIGURE 5
SINGLE-PHASE WIRING DIAGRAM (-)PNE/(-)PPC*JAZ (208/230V SINGLE PHASE)**

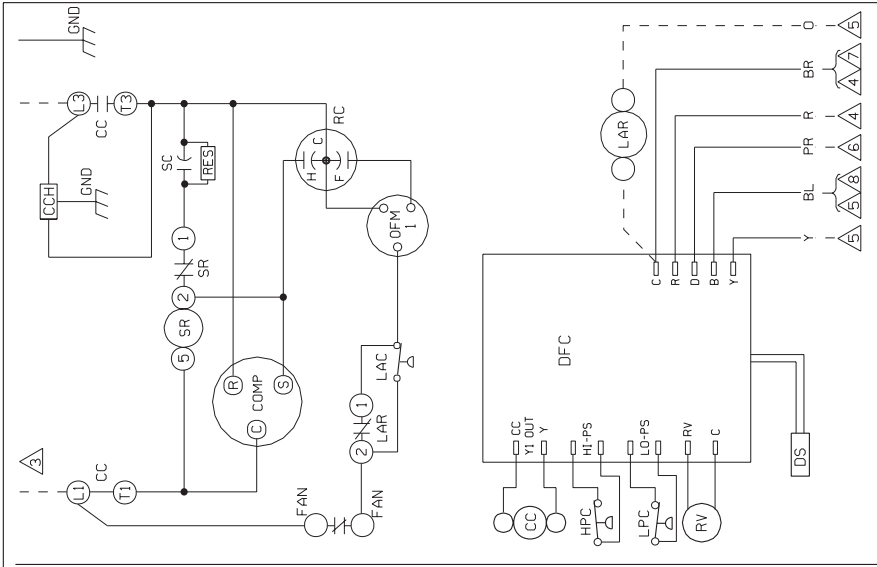

WIRING SCHEMATIC

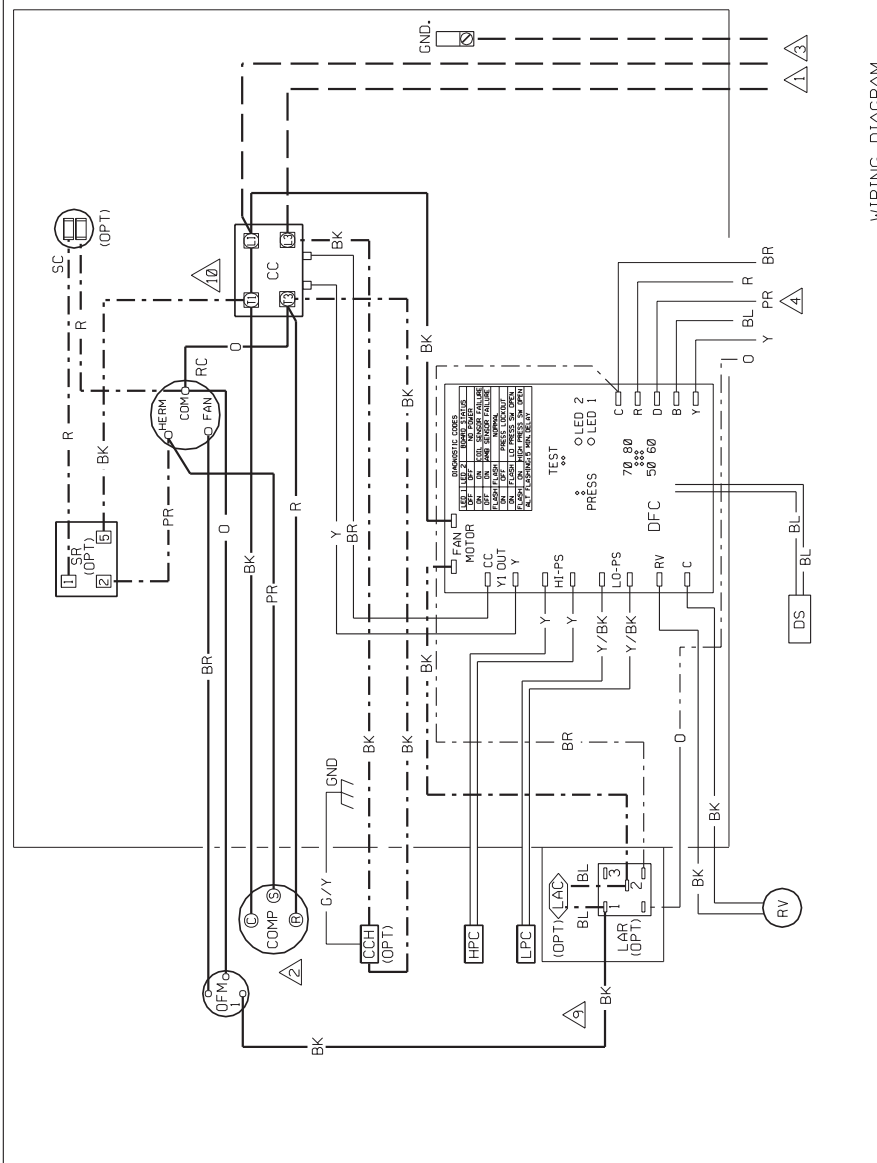

WIRING DIAGRAM

<p>WIRE COLOR CODE</p> <p>BK---BLACK BR---BROWN BL---BLUE G---GREEN GR---GRAY O---ORANGE PR---PURPLE R---RED W---WHITE Y---YELLOW</p> <p>ELECTRICAL WIRING DIAGRAM REMOTE HEAT PUMP SINGLE PHASE DEMAND DEFROST CONTROL (RANCO: DDL)</p> <p>DR:BY MCB APP:BY DATE DWG. NO. REV B-25-05 90-101229-03 02</p>	<p>WIRING INFORMATION</p> <p>LINE VOLTAGE -FACTORY STANDARD -FACTORY OPTION -FIELD INSTALLED LOW VOLTAGE -FACTORY STANDARD -FIELD INSTALLED</p> <p>REPLACEMENT WIRE -MUST BE THE SAME SIZE AND TYPE OF INSULATION AS ORIGINAL (105 C° MIN.) -CABINET MUST BE PERMANENTLY GROUNDED AND CONFORM TO I.E.C., N.E.C., C.E.C. AND LOCAL CODES AS APPLICABLE.</p>	<p>NOTES:</p> <ol style="list-style-type: none"> CONNECTORS SUITABLE FOR USE WITH COPPER CONDUCTORS ONLY. COMPRESSOR MOTOR THEMATICALLY PROTECTED AND ALL 3 PHASE ARE PROTECTED UNDER PRIMARY SINGLE PHASE CONDITIONS. CONNECT FIELD WIRING IN GROUND RAIN-TIGHT CONDUIT TO 60 HERTZ FUSE DISCONNECT, VOLTAGE AND PHASE PER RATING PLATE. LOW VOLTAGE CIRCUIT TO BE N.E.C. CLASS 2 WITH A CLASS 2 TRANSFORMER 24 VOLT, 60 HERTZ. TO THERMOSTAT SUB-BASE. REFER TO SYSTEM SCHEMATICS OR SCHEMATICS ON INDOOR SECTION FOR LOW VOLTAGE CONTROL WIRING. THIS WIRE IS USED TO TURN ON STRIP HEAT DURING DEFROST. OMIT CONNECTION FOR MOST ECONOMICAL OPERATION. TO HEAT PUMP MONITOR 2.5 VA MAX. WHEN USED. THIS COMPONENT IS ENERGIZED IN HEATING MODE. IF LAC/LAR IS NOT USED, CONNECT BLACK WIRE FROM OFPM TO DFC FAN MOTOR. BLACK WIRE FROM SR (5) TO CC (1) DELETED WHEN PTCR IS USED. 	<p>COMPONENT CODE</p> <p>CCH COMPRESSOR CRANKCASE HEATER COMP COMPRESSOR MOTOR GND GROUNDING CHOST HPC HIGH PRES. CUT-OUT CONTROL LAC LOW AMBIENT COOLING CONTROL LFC LOW PRESSURE CUT OUT CONTROL OFPM OUTDOOR FAN MOTOR RC RUN COMPACTOR RV REVERSING VALVE SR START RELAY DFC DEFROST CONTROL</p> <p>DWG. NO. REV 90-101229-03 02</p>
---	---	--	--

FIGURE 6
SINGLE-PHASE WIRING DIAGRAM (-)PNE-***JBZ (208/230V SINGLE PHASE)

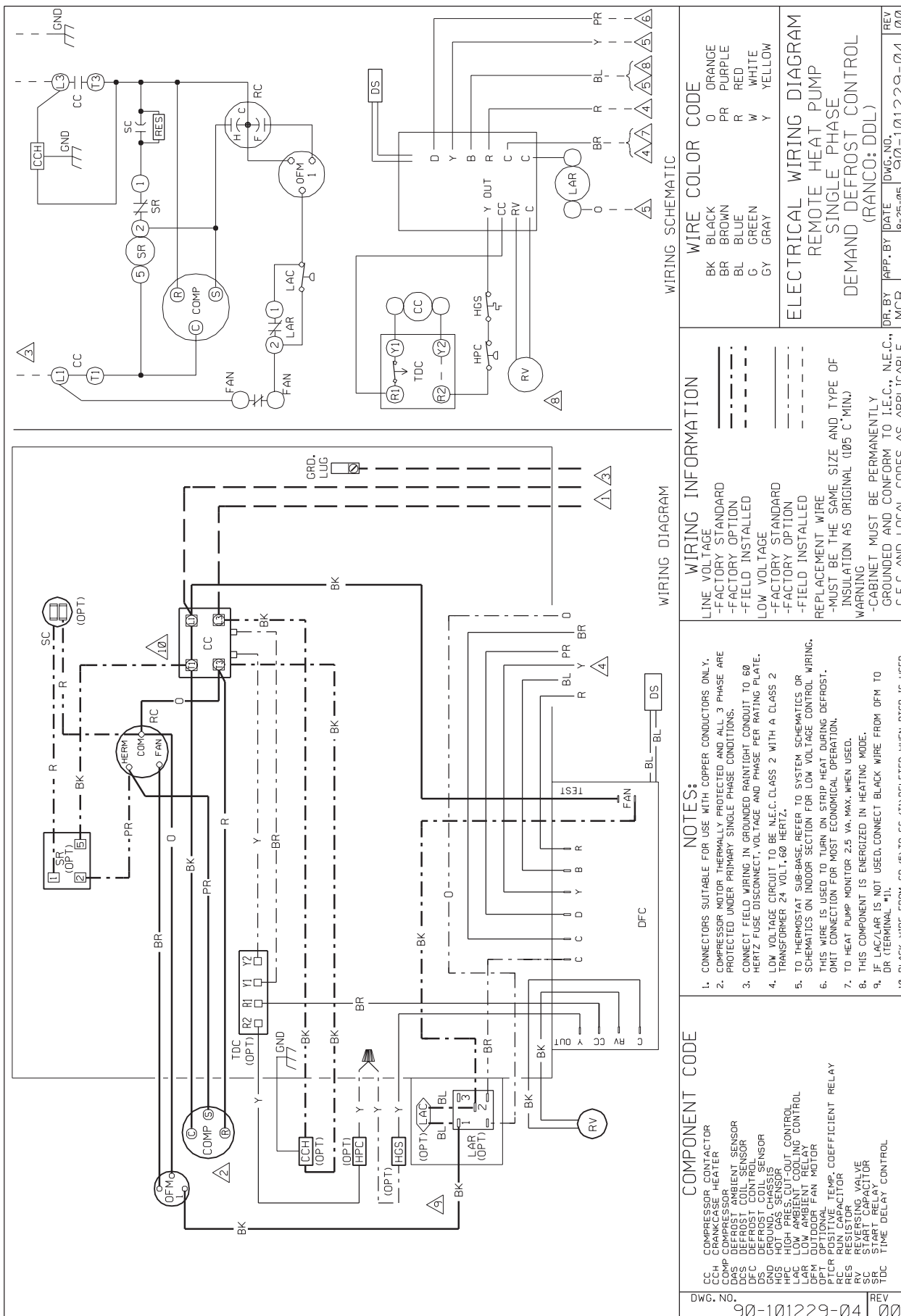

WIRING INFORMATION

- LINE VOLTAGE
- FACTORY STANDARD
- FACTORY OPTION
- FIELD INSTALLED
- LOW VOLTAGE
- FACTORY STANDARD
- FACTORY OPTION
- FIELD INSTALLED
- REPLACEMENT WIRE
- MUST BE THE SAME SIZE AND TYPE OF INSULATION AS ORIGINAL (105 C° MIN.)
- WARNING
- CABINET MUST BE PERMANENTLY GROUNDED AND CONFORM TO I.E.C., N.E.C., C.E.C. AND LOCAL CODES AS APPLICABLE.

NOTES:

1. CONNECTORS SUITABLE FOR USE WITH COPPER CONDUCTORS ONLY.
2. COMPRESSOR MOTOR THERMALLY PROTECTED AND ALL 3 PHASE ARE PROTECTED UNDER PRIMARY SINGLE PHASE CONDITIONS.
3. CONNECT FIELD WIRING IN GROUNDED RAIN-TIGHT CONDUIT TO 60 HERTZ FUSE DISCONNECT, VOLTAGE AND PHASE PER RATING PLATE.
4. LOW VOLTAGE CIRCUIT TO BE N.E.C. CLASS 2 WITH A CLASS 2 TRANSFORMER 24 VOLT, 60 HERTZ.
5. TO THERMOSTAT SUB-BASE REFER TO SYSTEM SCHEMATICS OR SCHEMATICS ON INDOOR SECTION FOR LOW VOLTAGE CONTROL WIRING.
6. THIS WIRE IS USED TO TURN ON STRIP HEAT DURING DEFROST. OMIT CONNECTION FOR MOST ECONOMICAL OPERATION.
7. TO HEAT PUMP MONITOR 2.5 VA. MAX. WHEN USED.
8. THIS COMPONENT IS ENERGIZED IN HEATING MODE.
9. IF LAC/LAR IS NOT USED, CONNECT BLACK WIRE FROM OFM TO DR (TERMINAL #1).
10. BLACK WIRE FROM SR (5) TO CC (11) DELETED WHEN PTCR IS USED.

WIRING SCHEMATIC

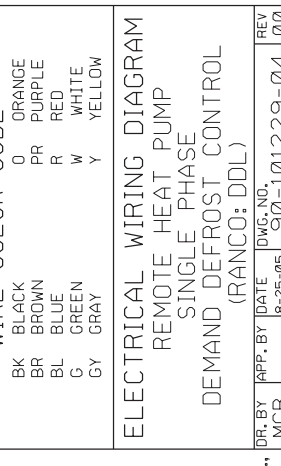

WIRING DIAGRAM

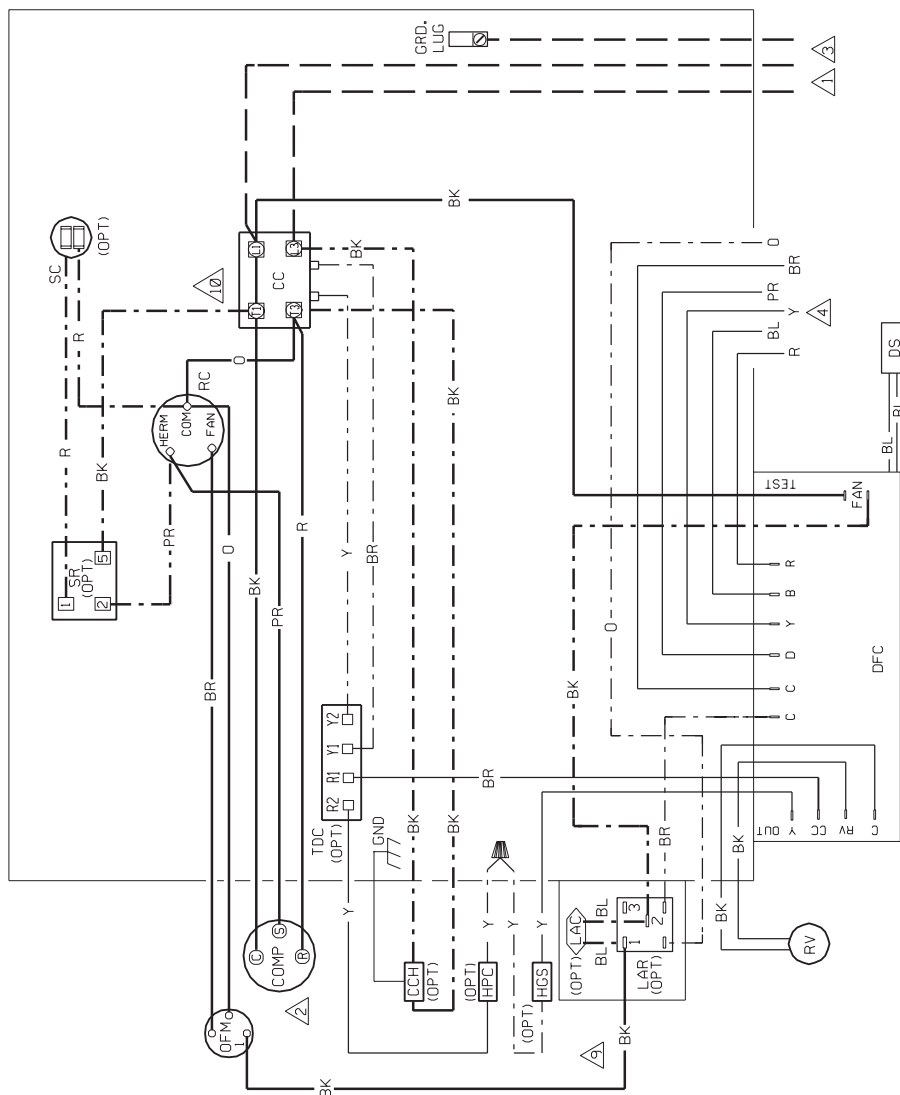
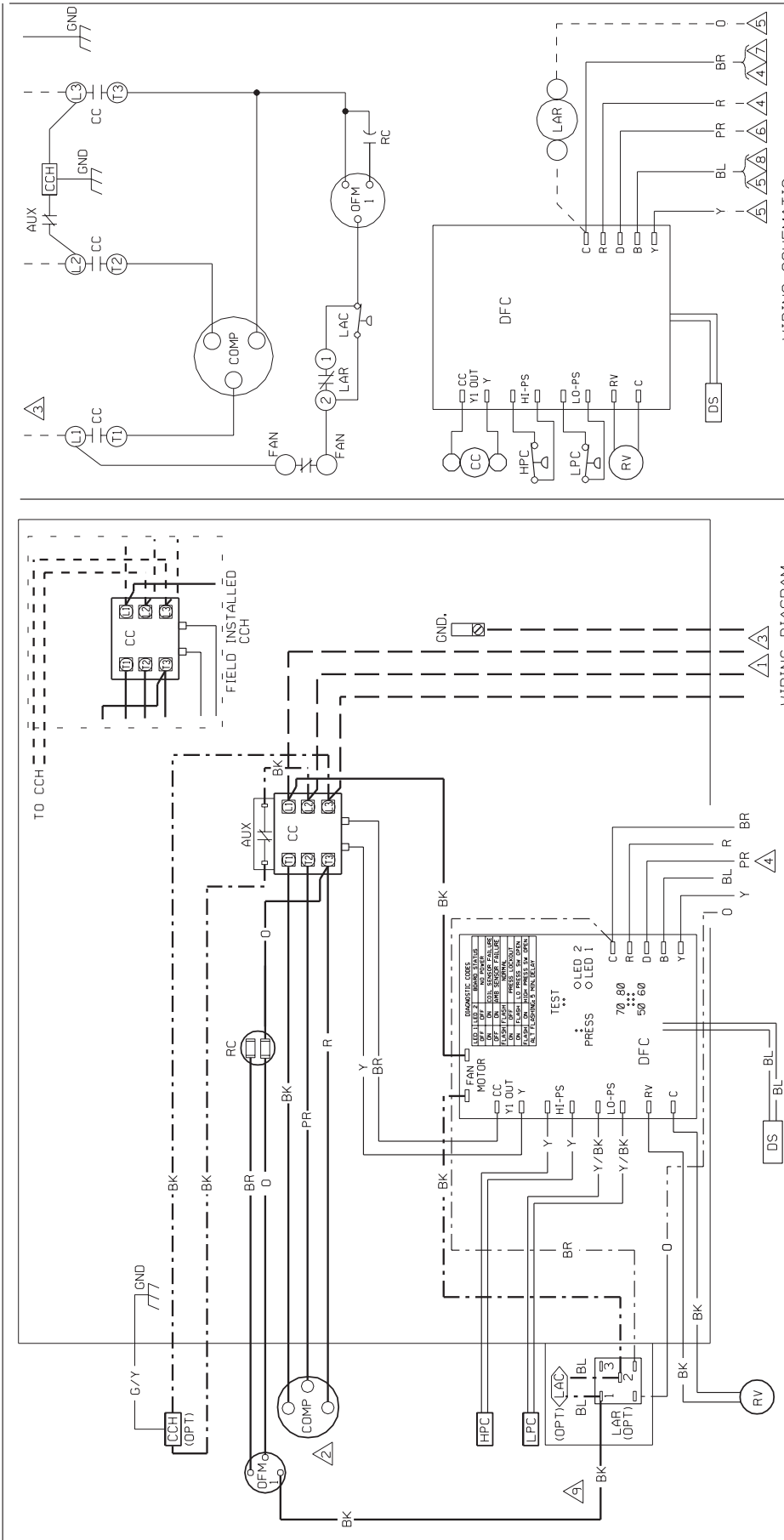

FIGURE 7
THREE-PHASE WIRING DIAGRAM (-)PNE-*CAZ (208/230V THREE-PHASE)**



WIRING SCHEMATIC

WIRE COLOR CODE	WIRE COLOR CODE		
BK	BLACK	O	ORANGE
BR	BROWN	PR	PURPLE
BL	BLUE	R	RED
G	GREEN	W	WHITE
GY	GRAY	Y	YELLOW

ELECTRICAL WIRING DIAGRAM
 REMOTE HEAT PUMP
 208/230V THREE PHASE
 DEMAND DEFROST CONTROL
 (RANCO:DDL)

WIRING INFORMATION

- LINE VOLTAGE
- FACTORY STANDARD
- FACTORY OPTION
- FIELD INSTALLED
- LOW VOLTAGE
- FACTORY STANDARD
- FACTORY OPTION
- FIELD INSTALLED
- REPLACEMENT WIRE
- MUST BE THE SAME SIZE AND TYPE OF INSULATION AS ORIGINAL (100% C MIN.)
- WARNING
- CABINET MUST BE PERMANENTLY GROUNDED AND CONFORM TO I.E.C., N.E.C., C.E.C. AND LOCAL CODES AS APPLICABLE.

- NOTES:**
- CONNECTORS SUITABLE FOR USE WITH COPPER CONDUCTORS ONLY.
 - COMPRESSOR MOTOR, THERMALLY PROTECTED AND ALL 3 PHASE ARE PROTECTED UNDER PRIMARY SINGLE PHASE CONDITIONS.
 - CONNECT FIELD WIRING IN GROUNDED RAINTIGHT CONDUIT TO 60 HERTZ FUSE DISCONNECT, VOLTAGE AND PHASE PER RATING PLATE.
 - LOW VOLTAGE CIRCUIT TO BE N.E.C. CLASS 2 WITH A CLASS 2 TRANSFORMER 24 VOLT, 60 HERTZ.
 - TO THERMOSTAT SUB-BASE, REFER TO SYSTEM SCHEMATICS OR SCHEMATICS ON INDOOR SECTION FOR LOW VOLTAGE CONTROL WIRING.
 - THIS WIRE IS USED TO TURN ON STRIP HEAT DURING DEFROST.
 - OMIT CONNECTION FOR MOST ECONOMICAL OPERATION.
 - TO HEAT PUMP MONITOR 2.5 VA. MAX. WHEN USED.
 - THIS COMPONENT IS ENERGIZED IN HEATING MODE.
 - IF LAC/LAR IS NOT USED, CONNECT BLACK WIRE FROM OFM TO DFC FAN MOTOR.

COMPONENT CODE

AUX	AUXILIARY SWITCH
CCH	CRANKCASE HEATER
COMP	COMPRESSOR
DFC	DEFROST CONTROL
GND	GROUND CHASSIS
HPC	HIGH PRESS. CUT-OUT CONTROL
LAC	LOW AMBIENT COOLING CONTROL
LPC	LOW PRESSURE CUT-OUT CONTROL
LO-PS	OUTDOOR FAN MOTOR
OPT	OPTIONAL
RV	REVERSING VALVE
SC	START CAPACITOR
SR	START RELAY

DWG. NO. 90-101229-05
 REV 03

FIGURE 8
THREE-PHASE — 480V/575V WIRING DIAGRAM (-)PNE-*DAZ (460V THREE-PHASE)**

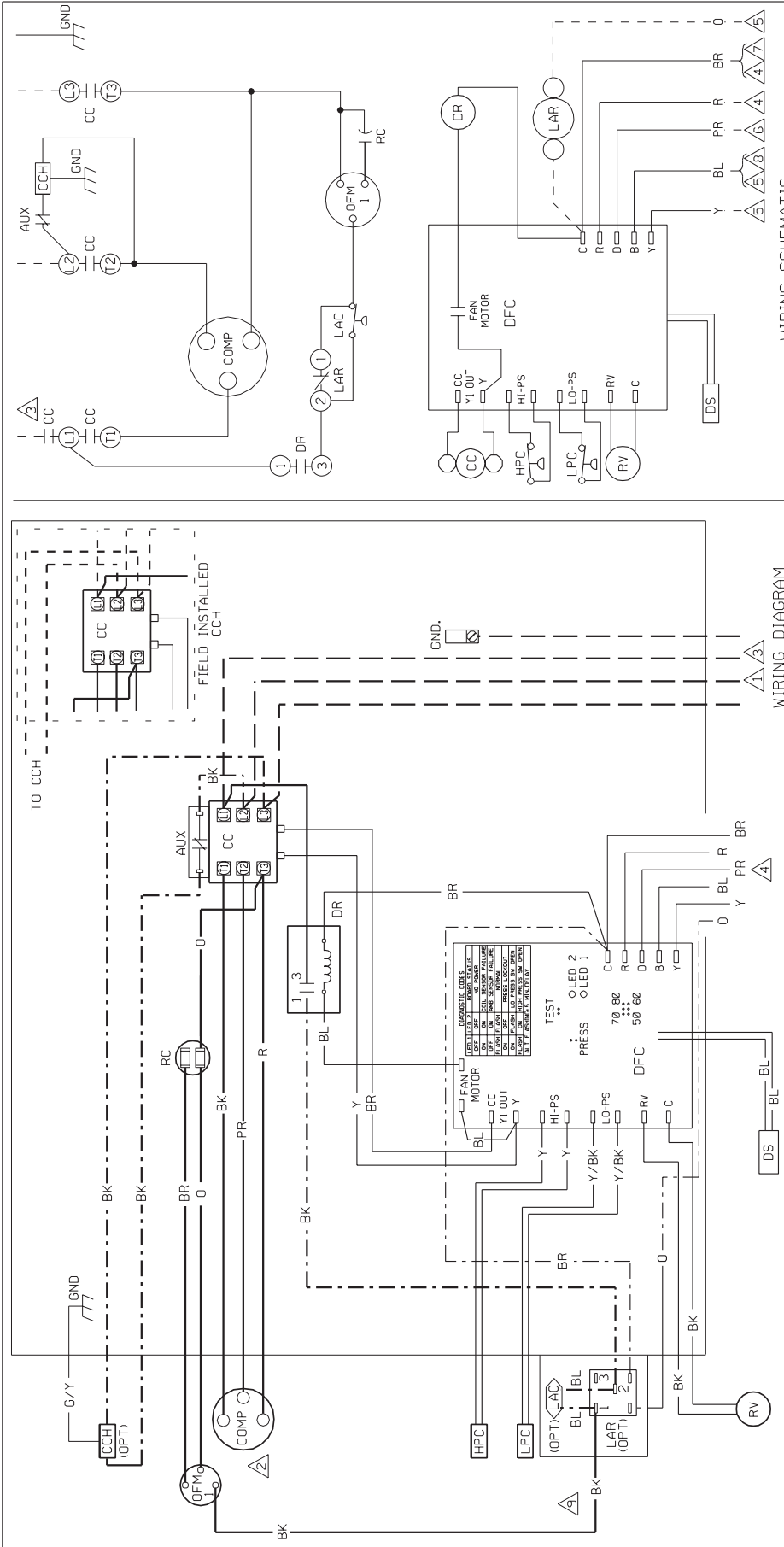

<p>COMPONENT CODE</p> <p>AUX: AUXILIARY SWITCH CCH: COMPRESSOR CONTACTOR CCH: CRANKCASE HEATER COMP: COMPRESSOR C: CAPACITOR DFC: DEFROST CONTROL DS: DEFROST SENSOR GND: GROUND, CHASSIS HPC: HIGH PRESS. CUT-OUT CONTROL LPC: LOW PRESS. CUT-OUT CONTROL LAR: LOW AMBIENT RELAY LAR: LOW PRESSURE CUT OUT CONTROL OFM: OUTDOOR FAN MOTOR RC: REVERSING VALVE RV: START RELAY SR: START RELAY</p>	<p>NOTES:</p> <ol style="list-style-type: none"> CONNECTORS SUITABLE FOR USE WITH COPPER CONDUCTORS ONLY. COMPRESSOR MOTOR THERMALLY PROTECTED AND ALL 3 PHASE ARE PROTECTED UNDER PRIMARY SINGLE PHASE CONDITIONS. CONNECT FIELD WIRING IN GROUNDED RAIN TIGHT CONDUIT TO 60 HERTZ FUSE DISCONNECT, VOLTAGE AND PHASE PER RATING PLATE. LOW VOLTAGE CIRCUIT TO BE N.E.C. CLASS 2 WITH A CLASS 2 TRANSFORMER 24 VOLT, 60 HERTZ. TO THERMOSTAT SUB-BASE REFER TO SYSTEM SCHEMATICS OR SCHEMATICS ON INDOOR SECTION FOR LOW VOLTAGE CONTROL WIRING. THIS WIRE IS USED TO TURN ON STRIP HEAT DURING DEFROST. OMIT CONNECTION FOR MOST ECONOMICAL OPERATION. TO HEAT PUMP MONITOR 2.5 VA. MAX. WHEN USED. THIS COMPONENT IS ENERGIZED IN HEATING MODE. IF LAC/LAR IS NOT USED, CONNECT BLACK WIRE FROM OFM TO DFC FAN MOTOR. 	<p>WIRING INFORMATION</p> <p>LINE VOLTAGE -FACTORY STANDARD -FACTORY OPTION -FIELD INSTALLED LOW VOLTAGE -FACTORY STANDARD -FIELD INSTALLED -FIELD INSTALLED REPLACEMENT WIRE -MUST BE THE SAME SIZE AND TYPE OF INSULATION AS ORIGINAL (105 C MIN.) WARNING -CABINET MUST BE PERMANENTLY GROUNDED AND CONFORM TO I.E.C., N.E.C., C.E.C. AND LOCAL CODES AS APPLICABLE.</p>	<p>WIRING SCHEMATIC</p> <p>WIRE COLOR CODE BK: BLACK BR: BROWN BL: BLUE G: GREEN GY: GRAY O: ORANGE PR: PURPLE R: RED W: WHITE Y: YELLOW</p>	<p>ELECTRICAL WIRING DIAGRAM REMOTE HEAT PUMP 460V/575V THREE PHASE DEMAND DEFROST CONTROL (RANCO: DDL)</p>
<p>DWG. NO. 90-101229-07</p>	<p>REV 03</p>	<p>DR. BY MCB</p>	<p>APP. BY DATE 9-19-95</p>	<p>DWG. NO. 90-101229-07</p>

