



The new degree of comfort.™

SUBMITTAL COVER SHEET

PROJECT NAME _____

LOCATION _____

ARCHITECT _____

ENGINEER _____

CONTRACTOR _____

SUBMITTED BY _____ DATE _____

UNIT SUMMARY

Quantity						
Unit Designation						
Model No.						
Total Cooling						
Sensible Cooling						
Air Ent. Evaporator						
Air Lvg. Evaporator						
Heating Input						
Heating Output						
CFM/ESP						
EER/SEER						
Electrical						
Minimum Ampacity						
Min.-Max. Breaker						
Net Unit Weight						
Accessory						
Catalog Form Number						

ACCESSORIES:

NOTES:



INTEGRATED HOME COMFORT

SUBMITTAL SHEET FOR RP14**F SERIES 1 1/2 TO 5 NOMINAL TON [5.28 TO 17.6 kW], 14 SEER HEAT PUMP UNITS

JOB NAME _____ LOCATION _____
 CONTRACTOR _____ ORDER NO. _____
 ENGINEER _____ UNIT MODEL NO. _____
 SUBMITTED FOR APPROVAL RECORD COIL MODEL NO. _____
 DATE _____ AIR HANDLER MODEL NO. _____

FEATURES FOR RP14**F SERIES HEAT PUMP UNITS

- The RP14**F series is designed to achieve 14 SEER with Coil only (for the dual fuel market) and PSC Air Handlers match ups.
- New composite base pan – dampens sound, captures louver panels, eliminates corrosion and reduces number of fasteners needed
- Improved tubing design – reduces vibration and stress, making unit quieter and reducing opportunity for leaks
- Optimized defrost characteristics – decrease defrosting and provide better home comfort
- Powder coat paint system – for a long lasting professional finish
- Optimized reversing valve sizing – improves shifting performance for quieter unit operation and increased life of the system
- Enhanced mufflers – help to dissipate vibration energy for quieter unit operation
- Scroll compressor – a sound abating feature added to the compressor significantly reduces noise when system transitions in and out of defrost mode
- Modern cabinet aesthetics – increased curb appeal with visually appealing design
- Curved louver panels – provide ultimate coil protection, enhance cabinet strength, and increased cabinet rigidity
- Optimized fan orifice – optimizes airflow and reduces unit sound
- Rust resistant screws – confirmed through 1500-hour salt spray testing
- PlusOne™ **Expanded Valve Space** – 3"-4"-5" service valve space – provides a minimum working area of 27-square inches for easier access
- Integrated heat pump lift receptacle – allows standard CPVC stands to be inserted into the base
- PlusOne™ **Triple Service Access** – 15" wide, industry leading corner service access – makes repairs easier and faster. The two fastener removable corner allows optimal access to internal unit components. Individual louver panels come out once fastener is removed, for faster coil cleaning and easier cabinet reassembly
- Diagnostic service window with two-fastener opening – provides access to the TXV valves and the heat pump reversing valve before opening the unit.
- External gauge port access – allows easy connection of "low-loss" gauge ports
- Single-row condenser coil – makes unit lighter and allows thorough coil cleaning to maintain "out of the box" performance
- 35% fewer cabinet fasteners and fastener-free base – allow for faster access to internal components and hassle-free panel removal
- Service trays – hold fasteners or caps during service calls
- QR code – provides technical information on demand for faster service calls
- Fan motor harness with extra-long wires – allows unit top to be removed without disconnecting fan wire

ACCESSORIES/OPTIONS

Compressor Crankcase Heater
 Low Ambient Control (Model No. RXAD-A08).....
 Compressor Sound Cover.....
 Compressor Hard Start Kit
 Classic Top Cap w/label (91-101123-21)

UNIT DATA

COOLING PERFORMANCE

EFFICIENCY SEER
 TOTAL CAPACITY* MBH [kW]
 SENSIBLE CAPACITY* MBH [kW]
 OUTDOOR DESIGN TEMP °F [°C] DB
 TEMP. OF AIR ENTERING
 EVAPORATOR COIL °F [°C] DB
 °F [°C] WB
 POWER INPUT REQUIREMENT kW
 (*uses blower motor heat)

HEATING PERFORMANCE

EFFICIENCY HSPF
 TOTAL CAPACITY* MBH [kW]
 OUTDOOR DESIGN TEMP °F [°C] DB
 TEMP. OF AIR ENTERING
 EVAPORATOR COIL °F [°C] DB

SUPPLY AIR BLOWER PERFORMANCE

TOTAL AIR SUPPLY CFM [L/s]
 TOTAL RESISTANCE EXTERNAL
 TO UNIT..... IWG
 BLOWER SPEED..... RPM
 POWER OUTPUT REQUIREMENT BHP
 MOTOR RATING HP [W]
 POWER INPUT REQUIREMENT kW

ELECTRICAL DATA

POWER SUPPLY Hz
 TOTAL UNIT AMPACITY..... AMPS
 MINIMUM WIRE SIZE AWG
 MAXIMUM OVERCURRENT DEVICE
 FUSES/HACR BREAKER AMPS

CLEARANCES

ACCESS SIDE 24" [609.6 mm]
 AIR INLETS 12" [304.8 mm]
 ABOVE UNIT 60" [1524 mm]

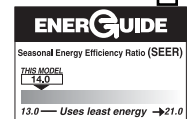

RP14F 18, 24, 30,
36, 42, 48, 60**

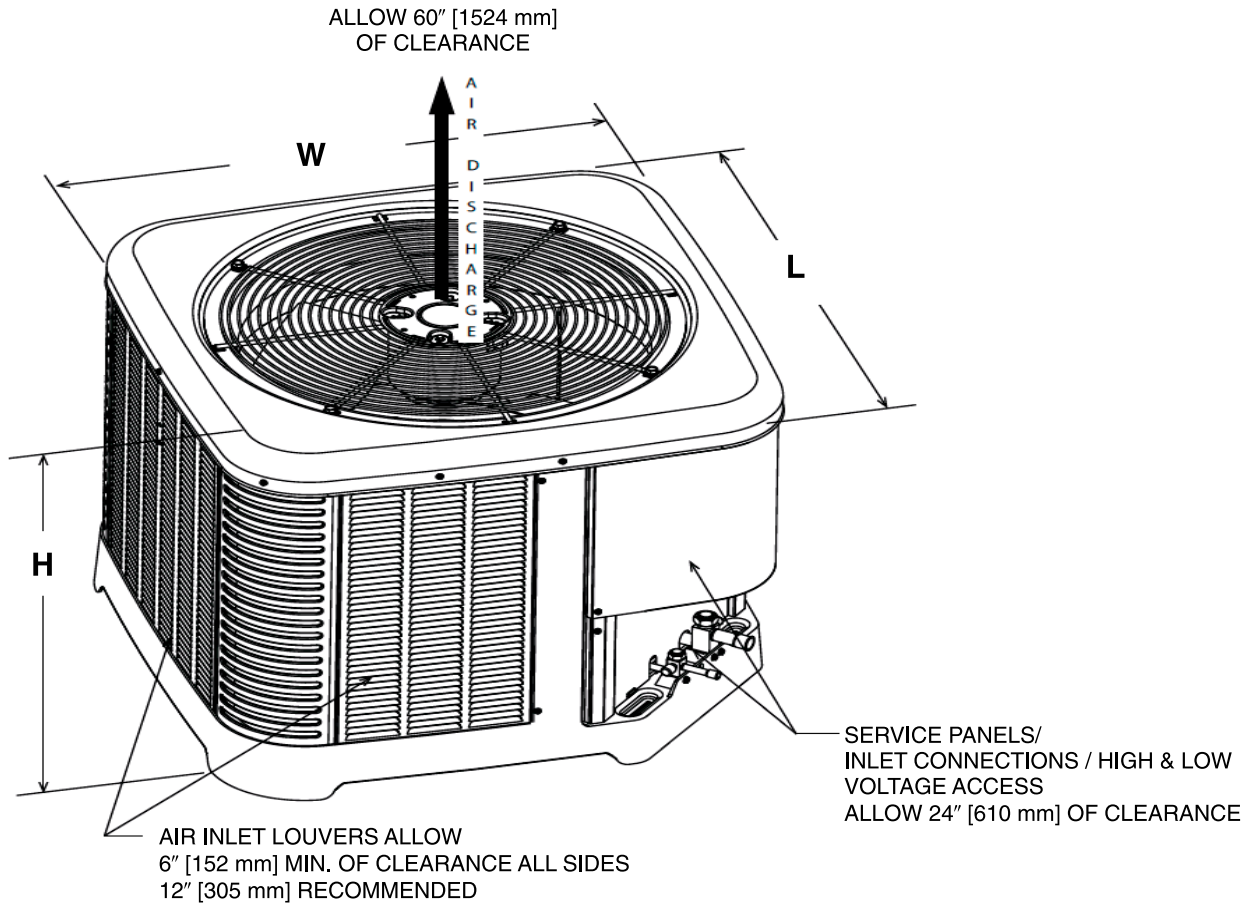

ST-A1226-02-00

Unit Dimensions

MODEL NUMBER	OPERATING						SHIPPING					
	H (Height)		L (Length)		W (Width)		H (Height)		L (Length)		W (Width)	
	INCHES	mm	INCHES	mm	INCHES	mm	INCHES	mm	INCHES	mm	INCHES	mm
RP1418F	25	635	29.75	755	29.75	755	26.75	679	32.38	822	32.38	822
RP1424F	25	635	29.75	755	29.75	755	26.75	679	32.38	822	32.38	822
RP1430F	31	787	33.75	857	33.75	857	32.75	831	32.38	822	32.38	822
RP1436F	35	889	33.75	857	33.75	857	36.75	933	36.38	924	36.38	924
RP1442F	35	889	33.75	857	33.75	857	36.75	933	36.38	924	36.38	924
RP1448F	39	990	35.75	908	35.75	908	40.75	1035	38.38	974	38.38	974
RP1460F	45	1143	35.75	908	35.75	908	46.75	1187	38.38	974	38.38	974

[] Designates Metric Conversions

Before proceeding with installation, refer to installation instructions packaged with each model, as well as complying with all Federal, State, Provincial, and Local codes, regulations, and practices.

Rheem Sales Company, Inc.
P.O. Box 17010, Fort Smith, AR 72917

"In keeping with its policy of continuous progress and product improvement, Rheem reserves the right to make changes without notice."