



Air

Package Air Conditioner
RLNL-C/H Series

The new degree of comfort.™

Rheem *Commercial Classic*® Series Package Air Conditioner



RLNL-C Series

With ClearControl™

Nominal Sizes 15-20 Tons [52.8-70.3 kW]

ASHRAE 90.1-2007 Compliant

RLNL-H Series

With ClearControl™

and VFD Technology

Nominal Sizes 15-25 Tons [52.8-87.9 kW]

ASHRAE 90.1-2010 Compliant



INTEGRATED AIR & WATER

FORM NO. S11-954 REV. 4

TABLE OF CONTENTS

Unit Features & Benefits	3-7
Model Number Identification	8
Options	9
Selection Procedure	10
General Data	
RLNL-C/H Series	11-18
Gross Systems Performance Data	
RLNL-C/H Series	19-22
Indoor Airflow Performance	
RLNL-C/H Series	23-28
Electrical Data	
RLNL-C/H Series	29-32
Electric Heater Kits	33-37
Dimensional Data	38-41
Accessories	42-56
Mechanical Specifications	57-62
Limited Warranty	63



RLNL-C/H STANDARD FEATURES INCLUDE:

- R-410A HFC refrigerant.
- Complete factory charged, wired and run tested.
- Scroll compressors with internal line break overload and high-pressure protection.
- Dual stage compressor on all models.
- Convertible airflow – vertical downflow or horizontal sideflow.
- TXV refrigerant metering system on each circuit.
- High Pressure and Low Pressure/Loss of charge protection standard on all models.
- Solid Core liquid line filter drier on each circuit.
- Single slab, single pass designed evaporator and condenser coils facilitate easy cleaning for maintaining high efficiencies.
- Cooling operation up to 125 degree F ambient.
- Foil faced insulation encapsulated throughout entire unit minimizes airborne fibers from the air stream.
- Hinged major access door with heavy-duty gasketing, 1/4 turn latches and door retainers.
- Slide Out Indoor fan assembly for added service convenience.
- Base pan with drawn supply and return opening for superior water management.
- Forkable base rails for easy handling and lifting.
- Single point electrical connections.
- Internally sloped slide out condensate pan conforms to ASHRAE 62 standards.
- High performance belt drive motor with variable pitch pulleys and quick adjust belt system.
- Permanently lubricated evaporator, condenser and gas heat inducer motors.
- Condenser motors are internally protected, totally enclosed with shaft down design.
- 2 inch filter standard with slide out design.
- 24 volt control system with resettable circuit breakers.
- Colored and labeled wiring.
- Copper tube/Aluminum Fin coils. (Exception: C241 has microchannel condenser coils)
- Supplemental electric heat provides 100% efficient heating.
- Factory Installed ClearControl™ (DDC) and sensors which can connect to LonWorks™ or BACnet® BAS systems for remote monitoring and control.
- -H models with Variable Frequency Drive (VFD) meet ASHRAE 90.1-2010 and California Title 24.

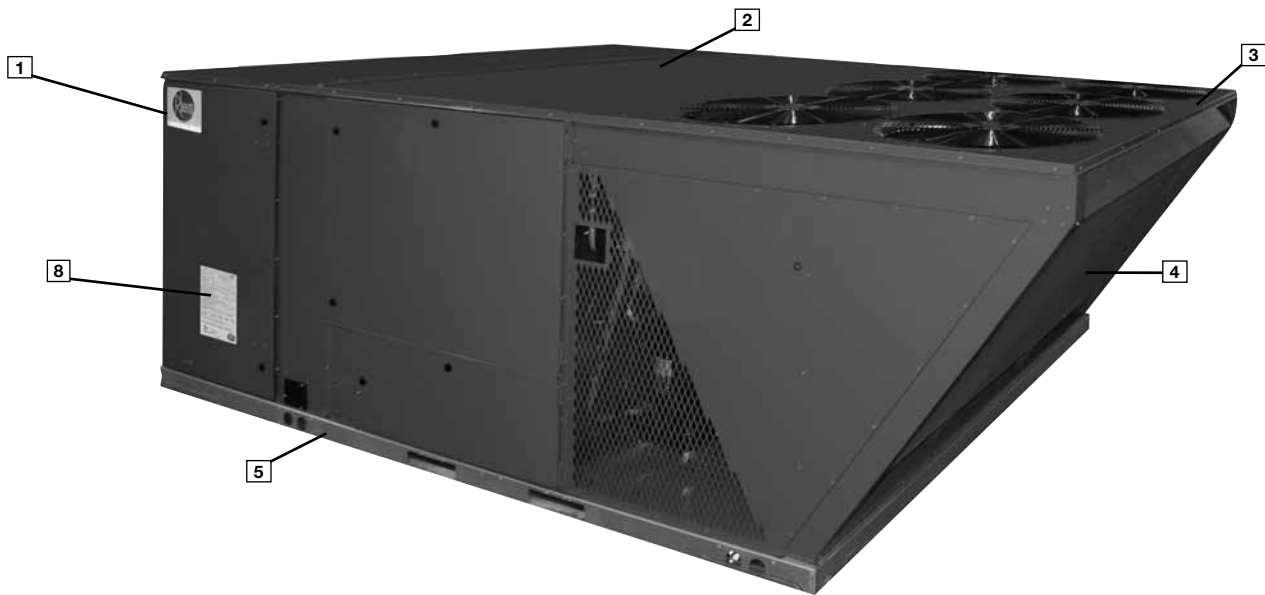

Rheem Package equipment is designed from the ground up with the latest features and benefits required to compete in today's market. The clean design stands alone in the industry and is a testament to the quality, reliability, ease of installation and serviceability that goes into each unit. Outwardly, the large Rheem *Commercial Series*™ label (1) identifies the brand to the customer. The sheet-metal cabinet (2) uses nothing less than 20-gauge material for structural components with an underlying coat of G90. To ensure the leak-proof integrity of these units, the design utilizes a top with a 1/8" drip lip (3), gasket-protected panels and screws. (4) The outdoor coil is slanted to protect from hail. Every Rheem package unit uses the toughest finish in the industry, using electro deposition baked-on enamel tested to withstand a rigorous 1000-hour salt spray test, per ASTM B117.

Anything built to last must start with the right foundation. In this case, the foundation is 14-gauge, commercial-grade, full-perimeter base rails (5), which integrate fork slots and rigging holes to save set-up time on the job site. The base pan is stamped, which forms a 1-1/8" flange around the supply and return cover and has eliminated the worry of water entering the conditioned space (6). The drainpan (7) is made of material that resists the growth of harmful bacteria and is sloped for the latest IAQ benefits. Furthermore, the drain pan slides out for easy cleaning. The insulation has been placed on the underside of the basepan, removing areas that would allow for potential moisture accumulation, which can facilitate growth of harmful bacteria. All insulation is secured with both adhesive and mechanical fasteners, and all edges are hidden.

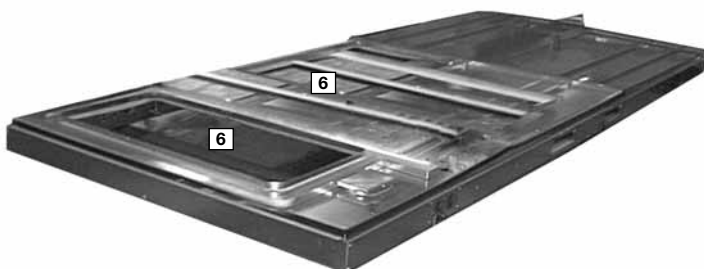

During development, each unit was tested to U.L. 1995, AHRI 340-360 and other Rheem-required reliability tests. Rheem adheres to stringent ISO 9002 quality procedures, and each unit bears the U.L. and AHRI certification labels located on the unit nameplate (8). Contractors can rest assured that when a Rheem package unit arrives at the job, it is ready to go with a factory charge and quality checks.

Access to all major compartments is from the front of the unit, including the filter and electrical compartment, blower compartment, heating section, and outdoor section. Each panel is permanently embossed with the compartment name (control/filter access, blower access and furnace access).

Electrical and filter compartment access is through a large, hinged-access panel with 1/4 turn latches. On the outside of the panel is the unit nameplate, which contains the model and serial number, electrical data and other important unit information.

The unit charging chart is located on the inside of the electrical and filter compartment door. Electrical wiring diagrams are found on the control box cover, which allows contractors to move them to more readable locations. To the right of the control box the model and serial number can be found. Having this information on the inside will assure model identification for the life of the product. The production line quality test assurance label is also placed in this location (9). The two-inch throwaway filters (10) are easily removed on a tracked system for easy replacement.

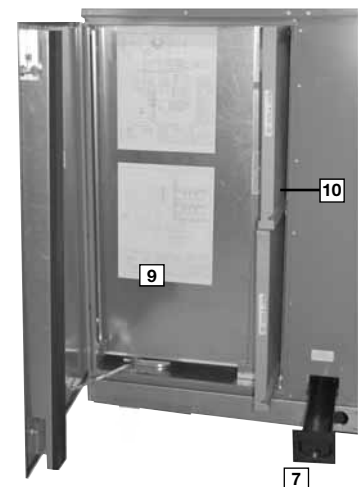



Inside the control box (11), each electrical component is clearly identified with a label that matches the component to the wire diagram for ease of trouble shooting. All wiring is numbered on each end of the termination and color-coded to match the wiring diagram. The control transformer has a low voltage circuit breaker that trips if a low voltage electrical short occurs. There is a blower contactor and contactor for each compressor.

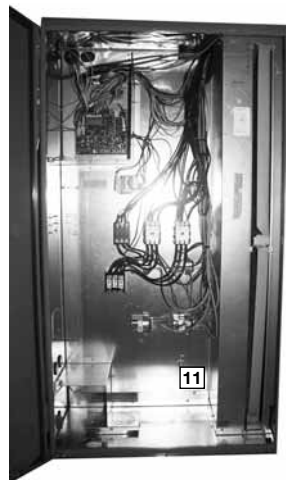

As part of the ClearControl™ system which allows real time monitoring and communication between rooftop units, the RLNL-C/H Package Air Conditioner has a Rooftop Unit Controller (RTU-C) factory mounted and wired in the control panel. The RTU-C is a solid-state microprocessor-based control board that provides flexible control and extensive diagnostics for all unit functions. The RTU-C through proportional/integral control algorithms perform specific unit functions that govern unit operation in response to: zone conditions, system temperatures, system pressures, ambient conditions and electrical inputs. The RTU-C features a 16 x 2 character LCD display and a five-button keypad for local configuration and direct diagnosis of the system (12). New features include a clogged filter switch (CFS), fan proving switch (FPS), return air temperature sensor (RAT), discharge air temperature sensor (DAT) and outdoor air temperature sensor (OAT). Freeze sensors (FS) are used in place of freezestats to allow measurement of refrigerant suction line temperatures. The RLNL-C/H Package Air Conditioner with the ClearControl™ is specifically designed to be applied in four distinct applications:

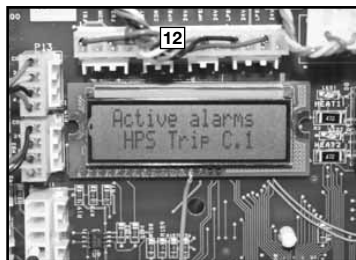

The RLNL-C/H is compatible with a third party building management system that supports the BACnet Application Specific Controller device profile, with the use of a field installed BACnet Communication Module. The BACnet Communication Module plugs onto the unit RTU-C controller and allows communication between ClearControl™ and the BACnet MSTP network. A zone sensor, a BACnet network zone sensor, a BACnet thermostat or DDC controller may be used to send the zone temperature or thermostat demands to the RTU-C. The BACnet Communication Module is compatible with MSTP EIA-485 daisy chain networks communicating at 38.4 bps. It is compatible with twisted pair, shielded cables.

The RLNL-C/H is compatible with a third party building management system that supports the LonMark Space Comfort Controller (SCC) functional profile or LonMark Discharge Air Controller (DAC) functional profile. This is accomplished with a field installed LonMark communication module. The LonMark Communication Module plugs onto the RTU-C controller and allows communication between ClearControl™ and a LonWorks Network. A zone sensor, a LonTalk network zone sensor, or a LonTalk thermostat or DDC controller may be used to send the zone temperature or thermostat demands to the RTU-C. The LonMark Communication Module utilizes an FTT-10A free topology transceiver communicating at 78.8 kbps. It is compatible with Echelon qualified twisted pair cable, Belden 8471 or NEMA Level 4 cables. The Module can communicate up to 1640 ft. with no repeater. The LonWorks limit of 64 nodes per segment applies to this device.

The RLNL-C/H is compatible with a programmable 24 volt thermostat. Connections are made via conventional thermostat screw terminals. Extensive unit status and diagnostics are displayed on the LCD screen of the RTU-C.

The RLNL-C/H is compatible with a zone sensor and mechanical or solid state time clock connected to the RTU-C. Extensive unit status and diagnostics are displayed on the LCD screen of the ClearControl™.

A factory or field installed Comfort Alert® module is available for power phase-monitoring protection and additional compressor diagnostics. The alarms can be displayed on the ClearControl™ display, through the (BAS) network, or connected to the "L-Terminal" of a thermostat for notification.



-H models with factory installed supply fan VFD (13) (variable frequency drive) optimizes energy usage year round by providing a lower speed for first stage cooling operation improving IEER's by up to 33% over the conventional constant fan system. Furthermore, operating in the constant fan mode at the reduced speed can use as little as 1/8th of the energy of a conventional constant fan system. Also, by operating at a lower speed on first stage cooling up to 126% more moisture is removed improving comfort during low load operation. The VFD equipped units meet California Title 24 and ASHRAE 90.1-2010 requirements for multi blower speed control. VFD also ramps up to the desired speed reducing stress on the supply fan components and reducing the noise from sudden inrush of air. Because the airflow is cut in half during first stage cooling and constant fan operation, noise is much less during these modes of operation.



For added convenience in the field, a factory-installed convenience outlet (14) is available. Low and High voltage can enter either from the side or through the base. Low-voltage connections are made through the low-voltage terminal strip. For ease of access, the U.L.-required low voltage barrier can be temporarily removed for low-voltage termination and then reinstalled. The high-voltage connection is terminated at the high voltage terminal block. The suggested mounting for the field-installed disconnect is on the exterior side of the electrical control box.



The blower compartment is to the right of the control box and can be accessed by 1/4 turn latches. To allow easy maintenance of the blower assembly, the entire assembly easily slides out by removing four #10 screws from

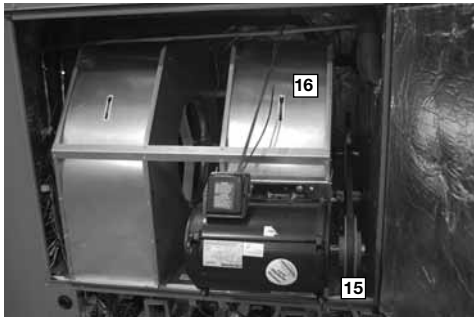

the blower assembly. The adjustable motor pulley (15) can easily be adjusted by loosening the bolts on either side of the motor mount. Removing the bolts allows for easy removal of the blower pulley by pushing the blower assembly up to loosen the belt. Once the pulley is removed, the motor sheave can be adjusted to the desired number of turns, ranging from 1 to 6 turns open. Where the demands for the job require high static, Rheem has high-static drives available that deliver nominal airflow up to 2" of static. By referring to the airflow performance tables listed in the installation instructions, proper static pressure and CFM requirements can be dialed in. The scroll housing (16) and blower scroll provide quiet and efficient airflow. The blower sheave is secured by an "H" bushing which firmly secures the pulley to the blower shaft for years of trouble-free operation. The "H" bushing allows for easy removal of the blower pulley from the shaft, as opposed to the use of a set screw, which can score the shaft, creating burrs that make blower-pulley removal difficult.

Also inside the blower compartment are the optional low-ambient controls (17). The optional low-ambient controls allow for operation of the compressors down to 0 degrees ambient temperature by cycling the outdoor fans on high pressure. The freeze sensor protects the compressor if the evaporator coil gets too cold (below freezing) due to low airflow, and allows monitoring of the suction line temperature on the controller display. The sensor clips on the suction line near the evaporator outlet.



Inside the blower compartment the interlaced evaporator can also be viewed. The evaporator uses enhanced fin technology for maximum heat transfer. The TXV metering device assures even distribution of refrigerant throughout the evaporator.

Wiring throughout the unit is neatly bundled and routed. Where wire harnesses go through the condenser bulkhead or blower deck, a molded wire harness assembly (18) provides an airtight and water-tight seal, and provides strain relief. Care is also taken to tuck raw edges of insulation behind sheet metal to improve indoor air quality.

The heating compartment contains the latest electric furnace technology on the market. The 100% efficient electric furnace can be factory-installed or easily field-installed. Built with ease-of-installation in mind, the electric furnace is completely wired up for slide-in, plug-and-play installation in the field. With choices of up to four kilowatt offerings, the contractor is assured to get the correct amount of heating output to meet the designed heating load.

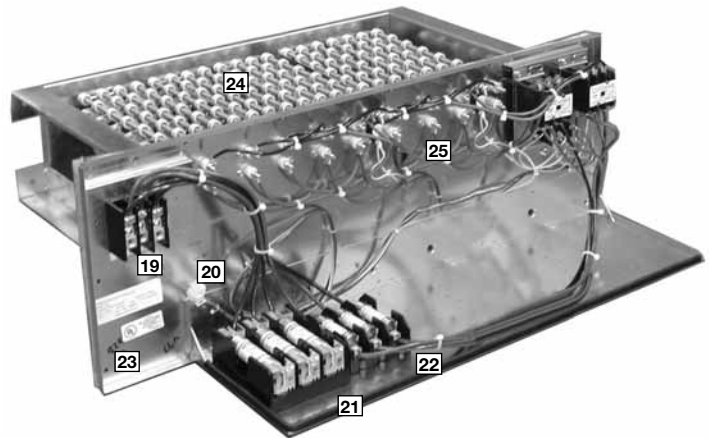

Power hook-up in the field is easy with single-point wiring to a terminal block (19) and a polarized plug for the low-voltage connection (20). The electric furnace comes with fuses for the unit (21) and for the electric furnace (22), and is UL certified (23). The electric heating elements are of a wound-wire construction (24) and isolated with ceramic bushings. The limit switch (25) protects the design from over-temperature conditions.



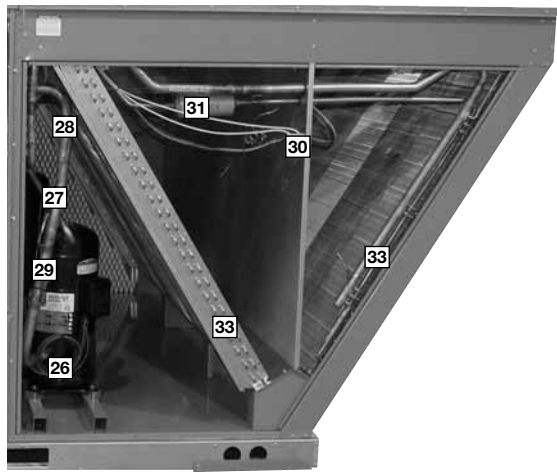

The compressor compartment houses the heartbeat of the unit. The scroll compressor (26) is known for its long life, and for reliable, quiet, and efficient operation. The suction and discharge lines are designed with shock loops (27) to absorb the strain and stress that the starting torque, steady state operation, and shut down cycle impose on the refrigerant tubing. Each compressor and circuit is independent for built-in redundancy, and each circuit is clearly marked throughout the system. Each unit has two stages of efficient cooling operation, first stage is approximately 50% of second stage.

In the outdoor section are the external gauge ports (28). With the gauge ports mounted externally, an accurate diagnosis of system operation can be performed quickly and easily. Also located in this area are the refrigerant safety devices: the low-pressure switches (29) and the high-pressure switches. (30) The high-pressure switches will shut off the compressors if pressures exceeding 610 psig are detected as may occur if the outdoor fan motor fails. The low pressure switches shut off the compressors if low pressure is detected due to loss of refrigerant charge. The factory-installed high and low pressure switches are brazed into the appropriate high or low side and wired appropriately.

Each unit comes standard with filter dryer (31). The condenser fan motor (32) can easily be accessed and maintained by removing the protective fan grille. The polarized plug connection allows the motor to be changed quickly and eliminates the need to snake wires through the unit.

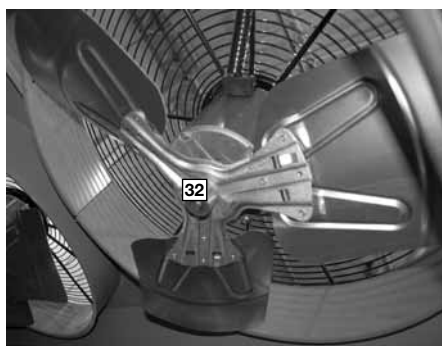

The outdoor coil uses the latest enhanced fin design (33) for the most effective method of heat transfer. The outdoor coil is slanted to protect the unit from Mother Nature.

Each unit is designed for both downflow or horizontal applications (34) for job configuration flexibility. The return air compartment can also contain an economizer (35). Three models exist; two for downflow applications, and one for horizontal applications. (A downflow economizer with factory installed smoke detector in the return section is available). Each unit is pre-wired for the economizer to allow quick plug-in installation. The downflow economizer is also available as a factory-installed option. The economizer, which provides free cooling when outdoor conditions are suitable and also provides fresh air to meet local requirements, comes standard with single enthalpy controls. The controls can be upgraded to dual enthalpy easily in the field. The direct drive actuator combined with gear drive dampers has eliminated the need for linkage adjustment in the field. The economizer control has a minimum position setpoint, an outdoor-air setpoint, a mix-air setpoint, and a CO₂ setpoint. Barometric relief is standard on all economizers. Power Exhaust is easily field-installed. The power exhaust is housed in the barometric relief opening and is easily slipped in with a plug-in assembly. The wire harness to the economizer also has accommodations for a smoke detector.

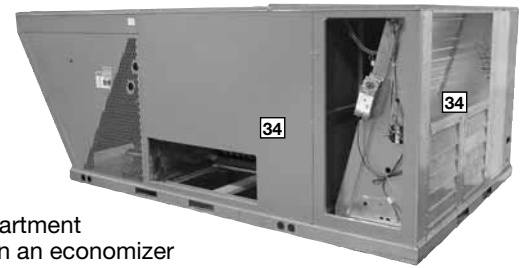

The damper minimum position, actual damper position, power exhaust on/off setpoint, mixed air temperature limit setpoint and Demand Controlled Ventilation (DCV) setpoint can be read and adjusted at the unit controller display or remotely through a network connection.

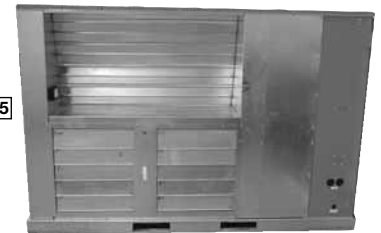

The Space CO₂ level, mixed air temperature, and Economizer Status (Free Cooling Available, Single or Dual Enthalpy) can be read at the unit controller display or remotely through a network connection. Economizer Faults will trigger a network Alarm and can be read at the unit controller display or remotely through a network connection.

The Rheem roofcurb (36) is made for toolless assembly at the jobsite by inserting a pin into the hinged corners (37), which makes the assembly process quick and easy.

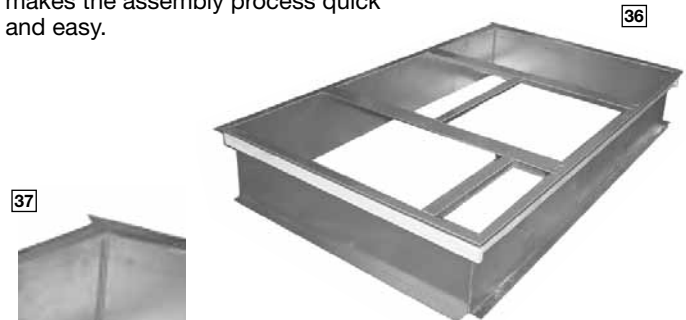

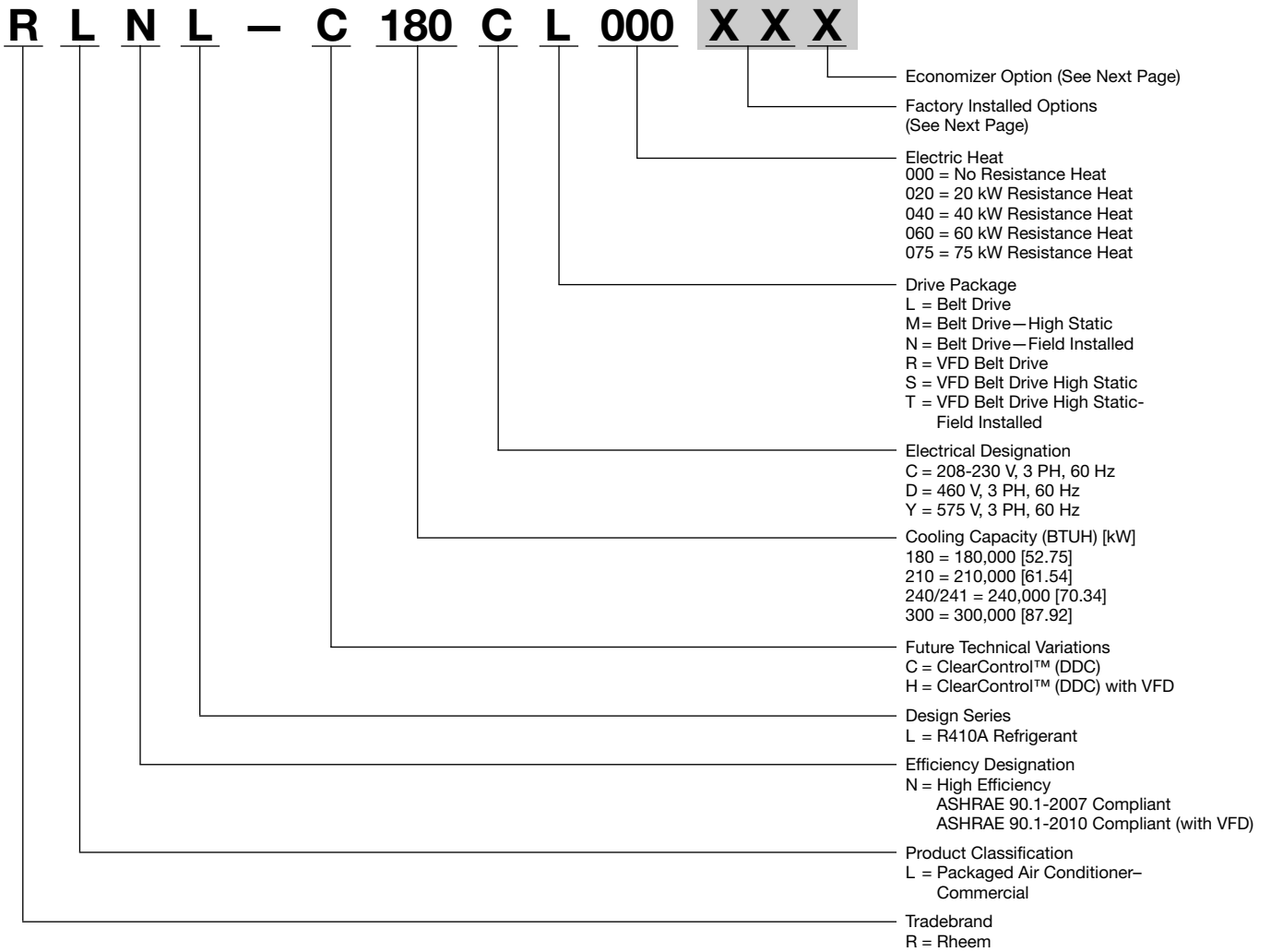

[] Designates Metric Conversions



FACTORY INSTALLED OPTION CODES FOR RLNL-C/H (15-25 TON) [52.8-87.9 kW]

Option Code	Hail Guard	Non-Powered Convenience Outlet	Low Ambient/ Comfort Alert
AD	X		
AG		X	
AR			X
JD	X		X
BJ	X	X	
JE		X	X
CZ	X	X	X

Example: RLNL-C/H180CL000XXX (where **XX** is factory installed option)

Example: No Options

RLNL-C/H180CL000

Example: No Options with factory installed economizer

RLNL-C/H180CL000AAH

Example: Options with low ambient/comfort alert and no factory installed economizer

RLNL-C/H180CL000ARA

Example: Options same as above with factory installed economizer

RLNL-C/H180CL000ARH

ECONOMIZER SELECTION FOR RLNL-C/H (15-25 TON) [52.8-87.9 kW]

Option Code	No Economizer	DDC Single Enthalpy Economizer* With Barometric Relief	DDC Single Enthalpy Economizer* With Barometric Relief and Smoke Detector
A	X		
H		X	
J			X

*"x" indicates factory installed option.

*Downflow economizer only.

Instructions for Factory Installed Option(s) Selection

Note: Three characters following the model number will be utilized to designate a factory-installed option or combination of options. If no factory option(s) is required, nothing follows the model number.

Step 1. After a basic rooftop model is selected, choose a *two-character* option code from the FACTORY INSTALLED OPTION SELECTION TABLE.

Proceed to Step 2.

Step 2. The last option code character is utilized for factory-installed economizers. Choose a character from the FACTORY INSTALLED ECONOMIZER SELECTION TABLE.

[] Designates Metric Conversions



To select an RLNL-C/H Cooling and Heating unit to meet a job requirement, follow this procedure, with example, using data supplied in this specification sheet.

1. DETERMINE COOLING AND HEATING REQUIREMENTS AND SPECIFIC OPERATING CONDITIONS FROM PLANS AND SPECS.

Example:

Voltage—	240 V – 3 Phase – 60 Hz
Total Cooling Capacity—	205,000 BTUH [60.0 kW]
Sensible Cooling Capacity—	155,000 BTUH [45.4 kW]
Heating Capacity—	235,000 BTUH [68.8 kW]
*Condenser Entering Air—	95°F [35°C] DB
*Evaporator Mixed Air Entering—	65°F [18.3] WB; 78°F [25.6] DB
*Indoor Air Flow (vertical)—	7200 CFM [3398 L/s]
*External Static Pressure—	0.70 in. WG [.17 kPa]

2. SELECT UNIT TO MEET COOLING REQUIREMENTS.

Since total cooling is within the range of a nominal 20 ton [70.3 kW] unit, enter cooling performance table at 95°F [35.0 °C] DB condenser inlet air. Interpolate between 63°F [17.2 °C] WB and 67°F [19.4 °C] WB to determine total and sensible capacity and power input for 65°F [18.3 °C] WB evaporator inlet air at 7725 CFM [3645 L/s] indoor air flow (table basis):

Total Cooling Capacity = 238,300 BTUH [69.76 kW]
Sensible Cooling Capacity = 192,500 BTUH [56.38 kW]
Power Input (Compressor and Cond. Fans) = 18,200 watts

Use formula in note ① to determine sensible capacity at 78°F [25.6] DB evaporator entering air:

$$192,550 + (1.10 \times 7,200 \times (1 - 0.11) \times (78 - 80))$$

Sensible Cooling Capacity = 178,452 BTUH [52.25 kW]

3. CORRECT CAPACITIES OF STEP 2 FOR ACTUAL AIR FLOW.

Select factors from airflow correction table at 7200 CFM [3398 L/s] and apply to data obtained in step 2 to obtain gross capacity:

Total Capacity = 238,300 x .99 = 235,868 BTUH [69.06 kW]
Sensible Capacity = 178,452 x 0.96 = 171,314 BTUH [50.16 kW]
Power Input = 18,200 x 0.99 = 18,018 Watts

These are Gross Capacities, not corrected for blower motor heat or power.

4. DETERMINE BLOWER SPEED AND WATTS TO MEET SYSTEM DESIGN.

Enter Indoor Blower performance table at 7200 CFM [3398 L/s]. Total ESP (external static pressure) per the spec of 0.70 in. WG [.17 kPa] includes the system duct and grilles. Add from the table 'Component Air Resistance', 0.01 in. WG [.00 kPa] for wet coil, 0.08 in. WG [.02 kPa] for downflow air flow, for a total selection static pressure of 0.79 (0.8) in. WG [.20 kPa], and determine:

RPM = 739
WATTS = 2,862
DRIVE = L (standard 5 H.P. motor)

5. CALCULATE INDOOR BLOWER BTUH HEAT EFFECT FROM MOTOR WATTS, STEP 4.

$$2,862 \times 3.412 = 9,765 \text{ BTUH [2.86 kW]}$$

6. CALCULATE NET COOLING CAPACITIES, EQUAL TO GROSS CAPACITY, STEP 3, MINUS INDOOR BLOWER MOTOR HEAT.

$$\text{Net Total Capacity} = 235,868 - 9,765 = 226,103 \text{ BTUH [66.21 kW]}$$

$$\text{Net Sensible Capacity} = 171,314 - 9,765 = 161,549 \text{ BTUH [47.30 kW]}$$

7. CALCULATE UNIT INPUT AND JOB EER.

$$\text{Total Power Input} = 18,018 \text{ (step 3)} + 2,862 \text{ (step 4)} = 20,880 \text{ Watts}$$

$$\text{EER} = \frac{\text{Net Total BTUH [kW] (step 6)}}{\text{Power Input, Watts (above)}} = \frac{226,103}{20,880} = 10.83$$

8. SELECT UNIT HEATING CAPACITY.

From Heater Kit Table select kW to meet heating capacity requirement; multiply kW x 3412 to convert to BTUH

Use 75 kW Heater Kit
Heater Kit Model: RXJJ-CE75C
Heater Kit Capacity: 245,323 BTUH [71.8 kW]

Add indoor blower heat effect (step 5) to Heater Kit Capacity to get total heating capacity:

$$245,323 + 9,765 = 255,088 \text{ BTUH [74.7 kW]}$$

9. CHOOSE MODEL RLNL-C/H240CL075

*NOTE: These operating conditions are typical of a commercial application in a 95°F/79°F [35°C/26°C] design area with indoor design of 76°F [24°C] DB and 50% RH and 10% ventilation air, with the unit roof mounted and centered on the zone it conditions by ducts.

[] Designates Metric Conversions



NOM. SIZES 15-25 TONS [52.8-87.9 kW] MODELS

Model RLNL- Series	C180CL	C180CM	C180DL	C180DM
Model RLNL- Series (with VFD)	H180CR	H180CS	H180DR	H180DS
Cooling Performance¹				CONTINUED →
Gross Cooling Capacity Btu [kW]	188,000 [53.47]	188,000 [53.47]	188,000 [53.47]	188,000 [53.47]
EER/SEER ²	11/NA	11/NA	11/NA	11/NA
Nominal CFM/AHRI Rated CFM [L/s]	6000/5900 [2831/2784]	6000/5900 [2831/2784]	6000/5900 [2831/2784]	6000/5900 [2831/2784]
AHRI Net Cooling Capacity Btu [kW]	172,000 [48.92]	172,000 [48.92]	172,000 [48.92]	172,000 [48.92]
Net Sensible Capacity Btu [kW]	125,700 [35.75]	125,700 [35.75]	125,700 [35.75]	125,700 [35.75]
Net Latent Capacity Btu [kW]	46,300 [13.17]	46,300 [13.17]	46,300 [13.17]	46,300 [13.17]
IEER ³	12.4/14.2	12.4/14.2	12.4/14.2	12.4/14.2
Net System Power [kW]	15.64	15.64	15.64	15.64
Compressor				
No./Type	2/Scroll	2/Scroll	2/Scroll	2/Scroll
Outdoor Sound Rating (dB)⁴	91	91	91	91
Outdoor Coil—Fin Type	Louvered	Louvered	Louvered	Louvered
Tube Type	Rifled	Rifled	Rifled	Rifled
Tube Size in. [mm] OD	0.375 [9.5]	0.375 [9.5]	0.375 [9.5]	0.375 [9.5]
Face Area sq. ft. [sq. m]	53.3 [4.95]	53.3 [4.95]	53.3 [4.95]	53.3 [4.95]
Rows / FPI [FPcm]	1 / 22 [9]	1 / 22 [9]	1 / 22 [9]	1 / 22 [9]
Indoor Coil—Fin Type	Louvered	Louvered	Louvered	Louvered
Tube Type	Rifled	Rifled	Rifled	Rifled
Tube Size in. [mm]	0.375 [9.5]	0.375 [9.5]	0.375 [9.5]	0.375 [9.5]
Face Area sq. ft. [sq. m]	26.67 [2.48]	26.67 [2.48]	26.67 [2.48]	26.67 [2.48]
Rows / FPI [FPcm]	2 / 18 [7]	2 / 18 [7]	2 / 18 [7]	2 / 18 [7]
Refrigerant Control	TX Valves	TX Valves	TX Valves	TX Valves
Drain Connection No./Size in. [mm]	1/1 [25.4]	1/1 [25.4]	1/1 [25.4]	1/1 [25.4]
Outdoor Fan—Type	Propeller	Propeller	Propeller	Propeller
No. Used/Diameter in. [mm]	4/24 [609.6]	4/24 [609.6]	4/24 [609.6]	4/24 [609.6]
Drive Type/No. Speeds	Direct/1	Direct/1	Direct/1	Direct/1
CFM [L/s]	16000 [7550]	16000 [7550]	16000 [7550]	16000 [7550]
No. Motors/HP	4 at 1/3 HP	4 at 1/3 HP	4 at 1/3 HP	4 at 1/3 HP
Motor RPM	1075	1075	1075	1075
Indoor Fan—Type	FC Centrifugal	FC Centrifugal	FC Centrifugal	FC Centrifugal
No. Used/Diameter in. [mm]	2/18x9 [457x229]	2/18x9 [457x229]	2/18x9 [457x229]	2/18x9 [457x229]
Drive Type	Belt (Adjustable)	Belt (Adjustable)	Belt (Adjustable)	Belt (Adjustable)
No. Speeds (Standard / VFD)	Single / Multiple	Single / Multiple	Single / Multiple	Single / Multiple
No. Motors	1	1	1	1
Motor HP	3	5	3	5
Motor RPM	1725	1725	1725	1725
Motor Frame Size	56	184	56	184
Filter—Type	Disposable	Disposable	Disposable	Disposable
Furnished	Yes	Yes	Yes	Yes
(NO.) Size Recommended in. [mm x mm x mm]	(8)2x25x20 [51x635x508]	(8)2x25x20 [51x635x508]	(8)2x25x20 [51x635x508]	(8)2x25x20 [51x635x508]
Refrigerant Charge Oz. [g] (Sys. 1/Sys. 2) [g]	205/211 [5812/5982]	205/211 [5812/5982]	205/211 [5812/5982]	205/211 [5812/5982]
Weights				
Net Weight lbs. [kg]	1826 [828]	1855 [841]	1826 [828]	1855 [841]
Ship Weight lbs. [kg]	1952 [885]	1981 [899]	1952 [885]	1981 [899]

NOTES:

- Cooling Performance is rated at 95° F ambient, 80° F entering dry bulb, 67° F entering wet bulb. Gross capacity does not include the effect of fan motor heat. AHRI capacity is net and includes the effect of fan motor heat. Units are suitable for operation to ±20% of nominal cfm. Units are certified in accordance with the Unitary Air Conditioner Equipment certification program, which is based on AHRI Standard 340/360.
- EER is rated at AHRI conditions and in accordance with DOE test procedures.
- Integrated Energy Efficiency Ratio (IEER) is rated in accordance with AHRI Standard 340/360.
- Outdoor Sound Rating shown is tested in accordance with AHRI Standard 270.
- 25 Ton Model is outside the scope of AHRI Standard 340/360.

[] Designates Metric Conversions



NOM. SIZES 15-25 TONS [52.8-87.9 kW] MODELS

Model RLNL- Series	C180YL	C180YM	C210CL H210CR	C210CM H210CS
Model RLNL- Series (with VFD)				CONTINUED →
Cooling Performance¹				
Gross Cooling Capacity Btu [kW]	188,000 [53.47]	188,000 [53.47]	212,000 [60.30]	212,000 [60.30]
EER/SEER ²	11/NA	11/NA	11/NA	11/NA
Nominal CFM/AHRI Rated CFM [L/s]	6000/5900 [2831/2784]	6000/5900 [2831/2784]	7000/7025 [3303/3315]	7000/7025 [3303/3315]
AHRI Net Cooling Capacity Btu [kW]	172,000 [48.92]	172,000 [48.92]	200,000 [56.88]	200,000 [56.88]
Net Sensible Capacity Btu [kW]	125,700 [35.75]	125,700 [35.75]	150,900 [42.91]	150,900 [42.91]
Net Latent Capacity Btu [kW]	46,300 [13.17]	46,300 [13.17]	49,100 [13.96]	49,100 [13.96]
IEER ³	12.4/14.2	12.4/14.2	12.4/14.2	12.4/14.2
Net System Power [kW]	15.64	15.64	18.18	18.18
Compressor				
No./Type	2/Scroll	2/Scroll	2/Scroll	2/Scroll
Outdoor Sound Rating (dB)⁴	91	91	91	91
Outdoor Coil—Fin Type	Louvered	Louvered	Louvered	Louvered
Tube Type	Rifled	Rifled	Rifled	Rifled
Tube Size in. [mm] OD	0.375 [9.5]	0.375 [9.5]	0.375 [9.5]	0.375 [9.5]
Face Area sq. ft. [sq. m]	53.3 [4.95]	53.3 [4.95]	53.3 [4.95]	53.3 [4.95]
Rows / FPI [FPcm]	1 / 22 [9]	1 / 22 [9]	2 / 18 [7]	2 / 18 [7]
Indoor Coil—Fin Type	Louvered	Louvered	Louvered	Louvered
Tube Type	Rifled	Rifled	Rifled	Rifled
Tube Size in. [mm]	0.375 [9.5]	0.375 [9.5]	0.375 [9.5]	0.375 [9.5]
Face Area sq. ft. [sq. m]	26.67 [2.48]	26.67 [2.48]	26.67 [2.48]	26.67 [2.48]
Rows / FPI [FPcm]	2 / 18 [7]	2 / 18 [7]	2 / 18 [7]	2 / 18 [7]
Refrigerant Control	TX Valves	TX Valves	TX Valves	TX Valves
Drain Connection No./Size in. [mm]	1/1 [25.4]	1/1 [25.4]	1/1 [25.4]	1/1 [25.4]
Outdoor Fan—Type	Propeller	Propeller	Propeller	Propeller
No. Used/Diameter in. [mm]	4/24 [609.6]	4/24 [609.6]	4/24 [609.6]	4/24 [609.6]
Drive Type/No. Speeds	Direct/1	Direct/1	Direct/1	Direct/1
CFM [L/s]	16000 [7550]	16000 [7550]	14800 [6984]	14800 [6984]
No. Motors/HP	4 at 1/3 HP	4 at 1/3 HP	4 at 1/3 HP	4 at 1/3 HP
Motor RPM	1075	1075	1075	1075
Indoor Fan—Type	FC Centrifugal	FC Centrifugal	FC Centrifugal	FC Centrifugal
No. Used/Diameter in. [mm]	2/18x9 [457x229]	2/18x9 [457x229]	2/18x9 [457x229]	2/18x9 [457x229]
Drive Type	Belt (Adjustable)	Belt (Adjustable)	Belt (Adjustable)	Belt (Adjustable)
No. Speeds (Standard / VFD)	Single	Single	Single / Multiple	Single / Multiple
No. Motors	1	1	1	1
Motor HP	3	5	3	5
Motor RPM	1725	1725	1725	1725
Motor Frame Size	56	184	56	184
Filter—Type	Disposable	Disposable	Disposable	Disposable
Furnished	Yes	Yes	Yes	Yes
(NO.) Size Recommended in. [mm x mm x mm]	(8)2x25x20 [51x635x508]	(8)2x25x20 [51x635x508]	(8)2x25x20 [51x635x508]	(8)2x25x20 [51x635x508]
Refrigerant Charge Oz. [g] (Sys. 1/Sys. 2) [g]	205/211 [5812/5982]	205/211 [5812/5982]	294/302 [8335/8562]	294/302 [8335/8562]
Weights				
Net Weight lbs. [kg]	1826 [828]	1855 [841]	2013 [913]	2042 [926]
Ship Weight lbs. [kg]	1952 [885]	1981 [899]	2140 [971]	2160 [980]

NOTES:

- Cooling Performance is rated at 95° F ambient, 80° F entering dry bulb, 67° F entering wet bulb. Gross capacity does not include the effect of fan motor heat. AHRI capacity is net and includes the effect of fan motor heat. Units are suitable for operation to ±20% of nominal cfm. Units are certified in accordance with the Unitary Air Conditioner Equipment certification program, which is based on AHRI Standard 340/360.
- EER is rated at AHRI conditions and in accordance with DOE test procedures.
- Integrated Energy Efficiency Ratio (IEER) is rated in accordance with AHRI Standard 340/360.
- Outdoor Sound Rating shown is tested in accordance with AHRI Standard 270.
- 25 Ton Model is outside the scope of AHRI Standard 340/360.

[] Designates Metric Conversions

NOM. SIZES 15-25 TONS [52.8-87.9 kW] MODELS

Model RLNL- Series	C210DL	C210DM	C210YL	C210YM
Model RLNL- Series (with VFD)	H210DR	H210DS		
Cooling Performance¹				
Gross Cooling Capacity Btu [kW]	212,000 [60.30]	212,000 [60.30]	212,000 [60.30]	212,000 [60.30]
EER/SEER ²	11/NA	11/NA	11/NA	11/NA
Nominal CFM/AHRI Rated CFM [L/s]	7000/7025 [3303/3315]	7000/7025 [3303/3315]	7000/7025 [3303/3315]	7000/7025 [3303/3315]
AHRI Net Cooling Capacity Btu [kW]	200,000 [56.88]	200,000 [56.88]	200,000 [56.88]	200,000 [56.88]
Net Sensible Capacity Btu [kW]	150,900 [42.91]	150,900 [42.91]	150,900 [42.91]	150,900 [42.91]
Net Latent Capacity Btu [kW]	49,100 [13.96]	49,100 [13.96]	49,100 [13.96]	49,100 [13.96]
IEER ³	12.4/14.2	12.4/14.2	12.4/14.2	12.4/14.2
Net System Power [kW]	18.18	18.18	18.18	18.18
Compressor				
No./Type	2/Scroll	2/Scroll	2/Scroll	2/Scroll
Outdoor Sound Rating (dB)⁴				
	91	91	91	91
Outdoor Coil—Fin Type				
Tube Type	Louvered	Louvered	Louvered	Louvered
Tube Size in. [mm] OD	Rifled	Rifled	Rifled	Rifled
Tube Size in. [mm] OD	0.375 [9.5]	0.375 [9.5]	0.375 [9.5]	0.375 [9.5]
Face Area sq. ft. [sq. m]	53.3 [4.95]	53.3 [4.95]	53.3 [4.95]	53.3 [4.95]
Rows / FPI [FPcm]	2 / 18 [7]	2 / 18 [7]	2 / 18 [7]	2 / 18 [7]
Indoor Coil—Fin Type				
Tube Type	Louvered	Louvered	Louvered	Louvered
Tube Type	Rifled	Rifled	Rifled	Rifled
Tube Size in. [mm]	0.375 [9.5]	0.375 [9.5]	0.375 [9.5]	0.375 [9.5]
Face Area sq. ft. [sq. m]	26.67 [2.48]	26.67 [2.48]	26.67 [2.48]	26.67 [2.48]
Rows / FPI [FPcm]	2 / 18 [7]	2 / 18 [7]	2 / 18 [7]	2 / 18 [7]
Refrigerant Control	TX Valves	TX Valves	TX Valves	TX Valves
Drain Connection No./Size in. [mm]	1/1 [25.4]	1/1 [25.4]	1/1 [25.4]	1/1 [25.4]
Outdoor Fan—Type				
No. Used/Diameter in. [mm]	Propeller	Propeller	Propeller	Propeller
No. Used/Diameter in. [mm]	4/24 [609.6]	4/24 [609.6]	4/24 [609.6]	4/24 [609.6]
Drive Type/No. Speeds	Direct/1	Direct/1	Direct/1	Direct/1
CFM [L/s]	14800 [6984]	14800 [6984]	14800 [6984]	14800 [6984]
No. Motors/HP	4 at 1/3 HP	4 at 1/3 HP	4 at 1/3 HP	4 at 1/3 HP
Motor RPM	1075	1075	1075	1075
Indoor Fan—Type				
No. Used/Diameter in. [mm]	FC Centrifugal	FC Centrifugal	FC Centrifugal	FC Centrifugal
No. Used/Diameter in. [mm]	2/18x9 [457x229]	2/18x9 [457x229]	2/18x9 [457x229]	2/18x9 [457x229]
Drive Type	Belt (Adjustable)	Belt (Adjustable)	Belt (Adjustable)	Belt (Adjustable)
No. Speeds (Standard / VFD)	Single / Multiple	Single / Multiple	Single	Single
No. Motors	1	1	1	1
Motor HP	3	5	3	5
Motor RPM	1725	1725	1725	1725
Motor Frame Size	56	184	56	184
Filter—Type				
Furnished	Disposable	Disposable	Disposable	Disposable
(NO.) Size Recommended in. [mm x mm x mm]	Yes	Yes	Yes	Yes
(NO.) Size Recommended in. [mm x mm x mm]	(8)2x25x20 [51x635x508]	(8)2x25x20 [51x635x508]	(8)2x25x20 [51x635x508]	(8)2x25x20 [51x635x508]
Refrigerant Charge Oz. [g] (Sys. 1/Sys. 2) [g]				
	294/302 [8335/8562]	294/302 [8335/8562]	294/302 [8335/8562]	294/302 [8335/8562]
Weights				
Net Weight lbs. [kg]	2013 [913]	2042 [926]	2013 [913]	2042 [926]
Ship Weight lbs. [kg]	2140 [971]	2160 [980]	2140 [971]	2160 [980]

CONTINUED →

NOTES:

- Cooling Performance is rated at 95° F ambient, 80° F entering dry bulb, 67° F entering wet bulb. Gross capacity does not include the effect of fan motor heat. AHRI capacity is net and includes the effect of fan motor heat. Units are suitable for operation to ±20% of nominal cfm. Units are certified in accordance with the Unitary Air Conditioner Equipment certification program, which is based on AHRI Standard 340/360.
- EER is rated at AHRI conditions and in accordance with DOE test procedures.
- Integrated Energy Efficiency Ratio (IEER) is rated in accordance with AHRI Standard 340/360.
- Outdoor Sound Rating shown is tested in accordance with AHRI Standard 270.
- 25 Ton Model is outside the scope of AHRI Standard 340/360.

[] Designates Metric Conversions



NOM. SIZES 15-25 TONS [52.8-87.9 kW] MODELS

Model RLNL- Series	C240CL	C240CM	C240CN	C240DL
Model RLNL- Series (with VFD)	H240CR	H240CS	H240CT	H240DR
Cooling Performance¹				CONTINUED →
Gross Cooling Capacity Btu [kW]	244,000 [69.40]	244,000 [69.40]	244,000 [69.40]	244,000 [69.40]
EER/SEER ²	11/NA	11/NA	11/NA	11/NA
Nominal CFM/AHRI Rated CFM [L/s]	8000/7725 [3775/3645]	8000/7725 [3775/3645]	8000/7725 [3775/3645]	8000/7725 [3775/3645]
AHRI Net Cooling Capacity Btu [kW]	228,000 [64.85]	228,000 [64.85]	228,000 [64.85]	228,000 [64.85]
Net Sensible Capacity Btu [kW]	165,600 [47.10]	165,600 [47.10]	165,600 [47.10]	165,600 [47.10]
Net Latent Capacity Btu [kW]	62,400 [17.75]	62,400 [17.75]	62,400 [17.75]	62,400 [17.75]
IEER ³	12.4/14.2	12.4/14.2	12.4/14.2	12.4/14.2
Net System Power [kW]	20.73	20.73	20.73	20.73
Compressor				
No./Type	2/Scroll	2/Scroll	2/Scroll	2/Scroll
Outdoor Sound Rating (dB)⁴				
	91	91	91	91
Outdoor Coil—Fin Type				
Tube Type	Louvered	Louvered	Louvered	Louvered
Tube Size in. [mm] OD	Rifled	Rifled	Rifled	Rifled
Tube Size in. [mm] OD	0.375 [9.5]	0.375 [9.5]	0.375 [9.5]	0.375 [9.5]
Face Area sq. ft. [sq. m]	53.3 [4.95]	53.3 [4.95]	53.3 [4.95]	53.3 [4.95]
Rows / FPI [FPcm]	2 / 22 [9]	2 / 22 [9]	2 / 22 [9]	2 / 22 [9]
Indoor Coil—Fin Type				
Tube Type	Louvered	Louvered	Louvered	Louvered
Tube Type	Rifled	Rifled	Rifled	Rifled
Tube Size in. [mm]	0.375 [9.5]	0.375 [9.5]	0.375 [9.5]	0.375 [9.5]
Face Area sq. ft. [sq. m]	26.67 [2.48]	26.67 [2.48]	26.67 [2.48]	26.67 [2.48]
Rows / FPI [FPcm]	3 / 13 [5]	3 / 13 [5]	3 / 13 [5]	3 / 13 [5]
Refrigerant Control	TX Valves	TX Valves	TX Valves	TX Valves
Drain Connection No./Size in. [mm]	1/1 [25.4]	1/1 [25.4]	1/1 [25.4]	1/1 [25.4]
Outdoor Fan—Type				
Propeller	Propeller	Propeller	Propeller	Propeller
No. Used/Diameter in. [mm]	6/24 [609.6]	6/24 [609.6]	6/24 [609.6]	6/24 [609.6]
Drive Type/No. Speeds	Direct/1	Direct/1	Direct/1	Direct/1
CFM [L/s]	19800 [9344]	19800 [9344]	19800 [9344]	19800 [9344]
No. Motors/HP	6 at 1/3 HP	6 at 1/3 HP	6 at 1/3 HP	6 at 1/3 HP
Motor RPM	1075	1075	1075	1075
Indoor Fan—Type				
FC Centrifugal	FC Centrifugal	FC Centrifugal	FC Centrifugal	FC Centrifugal
No. Used/Diameter in. [mm]	2/18x9 [457x229]	2/18x9 [457x229]	2/18x9 [457x229]	2/18x9 [457x229]
Drive Type	Belt (Adjustable)	Belt (Adjustable)	Belt (Adjustable)	Belt (Adjustable)
No. Speeds (Standard / VFD)	Single / Multiple	Single / Multiple	Single / Multiple	Single / Multiple
No. Motors	1	1	1	1
Motor HP	5	7 1/2	7 1/2	5
Motor RPM	1725	1725	1725	1725
Motor Frame Size	184	213	213	184
Filter—Type				
Disposable	Disposable	Disposable	Disposable	Disposable
Furnished	Yes	Yes	Yes	Yes
(NO.) Size Recommended in. [mm x mm x mm]	(8)2x25x20 [51x635x508]	(8)2x25x20 [51x635x508]	(8)2x25x20 [51x635x508]	(8)2x25x20 [51x635x508]
Refrigerant Charge Oz. [g] (Sys. 1/Sys. 2) [g]				
	402/331 [11397/9384]	402/331 [11397/9384]	402/331 [11397/9384]	402/331 [11397/9384]
Weights				
Net Weight lbs. [kg]	2151 [976]	2189 [993]	2187 [992]	2151 [976]
Ship Weight lbs. [kg]	2277 [1033]	2315 [1050]	2314 [1050]	2277 [1033]

NOTES:

- Cooling Performance is rated at 95° F ambient, 80° F entering dry bulb, 67° F entering wet bulb. Gross capacity does not include the effect of fan motor heat. AHRI capacity is net and includes the effect of fan motor heat. Units are suitable for operation to ±20% of nominal cfm. Units are certified in accordance with the Unitary Air Conditioner Equipment certification program, which is based on AHRI Standard 340/360.
- EER is rated at AHRI conditions and in accordance with DOE test procedures.
- Integrated Energy Efficiency Ratio (IEER) is rated in accordance with AHRI Standard 340/360.
- Outdoor Sound Rating shown is tested in accordance with AHRI Standard 270.
- 25 Ton Model is outside the scope of AHRI Standard 340/360.

[] Designates Metric Conversions

NOM. SIZES 15-25 TONS [52.8-87.9 kW] MODELS

Model RLNL- Series	C240DM	C240DN	C240YL	C240YM
Model RLNL- Series (with VFD)	H240DS	H240DT		
Cooling Performance¹				
Gross Cooling Capacity Btu [kW]	244,000 [69.40]	244,000 [69.40]	244,000 [69.40]	244,000 [69.40]
EER/SEER ²	11/NA	11/NA	11/NA	11/NA
Nominal CFM/AHRI Rated CFM [L/s]	8000/7725 [3775/3645]	8000/7725 [3775/3645]	8000/7725 [3775/3645]	8000/7725 [3775/3645]
AHRI Net Cooling Capacity Btu [kW]	228,000 [64.85]	228,000 [64.85]	228,000 [64.85]	228,000 [64.85]
Net Sensible Capacity Btu [kW]	165,600 [47.10]	165,600 [47.10]	165,600 [47.10]	165,600 [47.10]
Net Latent Capacity Btu [kW]	62,400 [17.75]	62,400 [17.75]	62,400 [17.75]	62,400 [17.75]
IEER ³	12.4/14.2	12.4/14.2	12.4	12.4
Net System Power [kW]	20.73	20.73	20.73	20.73
Compressor				
No./Type	2/Scroll	2/Scroll	2/Scroll	2/Scroll
Outdoor Sound Rating (dB)⁴				
	91	91	91	91
Outdoor Coil—Fin Type				
Tube Type	Louvered	Louvered	Louvered	Louvered
Tube Size in. [mm] OD	Rifled	Rifled	Rifled	Rifled
Tube Size in. [mm] OD	0.375 [9.5]	0.375 [9.5]	0.375 [9.5]	0.375 [9.5]
Face Area sq. ft. [sq. m]	53.3 [4.95]	53.3 [4.95]	53.3 [4.95]	53.3 [4.95]
Rows / FPI [FPcm]	2 / 22 [9]	2 / 22 [9]	2 / 22 [9]	2 / 22 [9]
Indoor Coil—Fin Type				
Tube Type	Louvered	Louvered	Louvered	Louvered
Tube Type	Rifled	Rifled	Rifled	Rifled
Tube Size in. [mm]	0.375 [9.5]	0.375 [9.5]	0.375 [9.5]	0.375 [9.5]
Face Area sq. ft. [sq. m]	26.67 [2.48]	26.67 [2.48]	26.67 [2.48]	26.67 [2.48]
Rows / FPI [FPcm]	3 / 13 [5]	3 / 13 [5]	3 / 13 [5]	3 / 13 [5]
Refrigerant Control	TX Valves	TX Valves	TX Valves	TX Valves
Drain Connection No./Size in. [mm]	1/1 [25.4]	1/1 [25.4]	1/1 [25.4]	1/1 [25.4]
Outdoor Fan—Type				
Propeller	Propeller	Propeller	Propeller	Propeller
No. Used/Diameter in. [mm]	6/24 [609.6]	6/24 [609.6]	6/24 [609.6]	6/24 [609.6]
Drive Type/No. Speeds	Direct/1	Direct/1	Direct/1	Direct/1
CFM [L/s]	19800 [9344]	19800 [9344]	19800 [9344]	19800 [9344]
No. Motors/HP	6 at 1/3 HP	6 at 1/3 HP	6 at 1/3 HP	6 at 1/3 HP
Motor RPM	1075	1075	1075	1075
Indoor Fan—Type				
FC Centrifugal	FC Centrifugal	FC Centrifugal	FC Centrifugal	FC Centrifugal
No. Used/Diameter in. [mm]	2/18x9 [457x229]	2/18x9 [457x229]	2/18x9 [457x229]	2/18x9 [457x229]
Drive Type	Belt (Adjustable)	Belt (Adjustable)	Belt (Adjustable)	Belt (Adjustable)
No. Speeds (Standard / VFD)	Single / Multiple	Single / Multiple	Single	Single
No. Motors	1	1	1	1
Motor HP	7 1/2	7 1/2	5	7 1/2
Motor RPM	1725	1725	1725	1725
Motor Frame Size	184	184	184	213
Filter—Type				
Disposable	Disposable	Disposable	Disposable	Disposable
Furnished	Yes	Yes	Yes	Yes
(NO.) Size Recommended in. [mm x mm x mm]	(8)2x25x20 [51x635x508]	(8)2x25x20 [51x635x508]	(8)2x25x20 [51x635x508]	(8)2x25x20 [51x635x508]
Refrigerant Charge Oz. [g] (Sys. 1/Sys. 2) [g]				
	402/331 [11397/9384]	402/331 [11397/9384]	402/331 [11397/9384]	402/331 [11397/9384]
Weights				
Net Weight lbs. [kg]	2189 [993]	2187 [992]	2151 [976]	2189 [993]
Ship Weight lbs. [kg]	2315 [1050]	2314 [1050]	2277 [1033]	2315 [1050]

CONTINUED →

NOTES:

- Cooling Performance is rated at 95° F ambient, 80° F entering dry bulb, 67° F entering wet bulb. Gross capacity does not include the effect of fan motor heat. AHRI capacity is net and includes the effect of fan motor heat. Units are suitable for operation to ±20% of nominal cfm. Units are certified in accordance with the Unitary Air Conditioner Equipment certification program, which is based on AHRI Standard 340/360.
- EER is rated at AHRI conditions and in accordance with DOE test procedures.
- Integrated Energy Efficiency Ratio (IEER) is rated in accordance with AHRI Standard 340/360.
- Outdoor Sound Rating shown is tested in accordance with AHRI Standard 270.
- 25 Ton Model is outside the scope of AHRI Standard 340/360.

[] Designates Metric Conversions



NOM. SIZES 15-25 TONS [52.8-87.9 kW] MODELS

Model RLNL- Series	C240YN	C241CL	C241CM	C241DL
Model RLNL- Series (with VFD)				
Cooling Performance¹				CONTINUED →
Gross Cooling Capacity Btu [kW]	244,000 [69.40]	240,000 [68.26]	240,000 [68.26]	240,000 [68.26]
EER/SEER ²	11/NA	11/NA	11/NA	11/NA
Nominal CFM/AHRI Rated CFM [L/s]	8000/7725 [3775/3645]	8000/7375 [3775/3480]	8000/7375 [3775/3480]	8000/7375 [3775/3480]
AHRI Net Cooling Capacity Btu [kW]	228,000 [64.85]	228,000 [64.85]	228,000 [64.85]	228,000 [64.85]
Net Sensible Capacity Btu [kW]	165,600 [47.10]	167,000 [47.50]	167,000 [47.50]	167,000 [47.50]
Net Latent Capacity Btu [kW]	62,400 [17.75]	63,000 [17.92]	63,000 [17.92]	63,000 [17.92]
IEER ³	12.4	12.4	12.4	12.4
Net System Power [kW]	20.73	20.73	20.73	20.73
Compressor				
No./Type	2/Scroll	2/Scroll	2/Scroll	2/Scroll
Outdoor Sound Rating (dB)⁴	91	91	91	91
Outdoor Coil—Fin Type	Louvered	Louvered	Louvered	Louvered
Tube Type	Rifled	MicroChannel	MicroChannel	MicroChannel
Tube Size in. [mm] OD	0.375 [9.5]	1 [25.4]	1 [25.4]	1 [25.4]
Face Area sq. ft. [sq. m]	53.3 [4.95]	50.8 [4.72]	50.8 [4.72]	50.8 [4.72]
Rows / FPI [FPcm]	2 / 22 [9]	1 / 23 [9]	1 / 23 [9]	1 / 23 [9]
Indoor Coil—Fin Type	Louvered	Louvered	Louvered	Louvered
Tube Type	Rifled	Rifled	Rifled	Rifled
Tube Size in. [mm]	0.375 [9.5]	0.375 [9.5]	0.375 [9.5]	0.375 [9.5]
Face Area sq. ft. [sq. m]	26.67 [2.48]	26.67 [2.48]	26.67 [2.48]	26.67 [2.48]
Rows / FPI [FPcm]	3 / 13 [5]	4 / 15 [6]	4 / 15 [6]	4 / 15 [6]
Refrigerant Control	TX Valves	TX Valves	TX Valves	TX Valves
Drain Connection No./Size in. [mm]	1/1 [25.4]	1/1 [25.4]	1/1 [25.4]	1/1 [25.4]
Outdoor Fan—Type	Propeller	Propeller	Propeller	Propeller
No. Used/Diameter in. [mm]	6/24 [609.6]	6/24 [609.6]	6/24 [609.6]	6/24 [609.6]
Drive Type/No. Speeds	Direct/1	Direct/1	Direct/1	Direct/1
CFM [L/s]	19800 [9344]	19800 [9344]	19800 [9344]	19800 [9344]
No. Motors/HP	6 at 1/3 HP	6 at 1/3 HP	6 at 1/3 HP	6 at 1/3 HP
Motor RPM	1075	1075	1075	1075
Indoor Fan—Type	FC Centrifugal	FC Centrifugal	FC Centrifugal	FC Centrifugal
No. Used/Diameter in. [mm]	2/18x9 [457x229]	2/18x9 [457x229]	2/18x9 [457x229]	2/18x9 [457x229]
Drive Type	Belt (Adjustable)	Belt (Adjustable)	Belt (Adjustable)	Belt (Adjustable)
No. Speeds (Standard / VFD)	Single	Single / Multiple	Single / Multiple	Single / Multiple
No. Motors	1	1	1	1
Motor HP	7 1/2	5	7 1/2	5
Motor RPM	1725	1725	1725	1725
Motor Frame Size	213	184	213	184
Filter—Type	Disposable	Disposable	Disposable	Disposable
Furnished	Yes	Yes	Yes	Yes
(NO.) Size Recommended in. [mm x mm x mm]	(8)2x25x20 [51x635x508]	(8)2x25x20 [51x635x508]	(8)2x25x20 [51x635x508]	(8)2x25x20 [51x635x508]
Refrigerant Charge Oz. [g] (Sys. 1/Sys. 2) [g]	402/331 [11397/9384]	271/227 [7683/6435]	271/227 [7683/6435]	271/227 [7683/6435]
Weights				
Net Weight lbs. [kg]	2187 [992]	2151 [976]	2189 [993]	2289 [1038]
Ship Weight lbs. [kg]	2314 [1050]	2251 [1021]	2289 [1038]	2389 [1084]

NOTES:

- Cooling Performance is rated at 95° F ambient, 80° F entering dry bulb, 67° F entering wet bulb. Gross capacity does not include the effect of fan motor heat. AHRI capacity is net and includes the effect of fan motor heat. Units are suitable for operation to ±20% of nominal cfm. Units are certified in accordance with the Unitary Air Conditioner Equipment certification program, which is based on AHRI Standard 340/360.
- EER is rated at AHRI conditions and in accordance with DOE test procedures.
- Integrated Energy Efficiency Ratio (IEER) is rated in accordance with AHRI Standard 340/360.
- Outdoor Sound Rating shown is tested in accordance with AHRI Standard 270.
- 25 Ton Model is outside the scope of AHRI Standard 340/360.

[] Designates Metric Conversions

NOM. SIZES 15-25 TONS [52.8-87.9 kW] MODELS

Model RLRL- Series	C241DM	C241YL	C241YM
Model RLRL- Series (with VFD)			
Cooling Performance¹			
Gross Cooling Capacity Btu [kW]	240,000 [68.26]	240,000 [68.26]	240,000 [68.26]
EER/SEER ²	11/NA	11/NA	11/NA
Nominal CFM/AHRI Rated CFM [L/s]	8000/7375 [3775/3480]	8000/7375 [3775/3480]	8000/7375 [3775/3480]
AHRI Net Cooling Capacity Btu [kW]	228,000 [64.85]	228,000 [64.85]	228,000 [64.85]
Net Sensible Capacity Btu [kW]	167,000 [47.50]	167,000 [47.50]	167,000 [47.50]
Net Latent Capacity Btu [kW]	63,000 [17.92]	63,000 [17.92]	63,000 [17.92]
IEER ³	12.4	12.4	12.4
Net System Power [kW]	20.73	20.73	20.73
Compressor	2/Scroll	2/Scroll	2/Scroll
No./Type	91	91	91
Outdoor Sound Rating (dB)⁴	Louvered	Louvered	Louvered
Outdoor Coil—Fin Type	MicroChannel	MicroChannel	MicroChannel
Tube Type	1 [25.4]	1 [25.4]	1 [25.4]
Tube Size in. [mm] OD	50.8 [4.72]	50.8 [4.72]	50.8 [4.72]
Face Area sq. ft. [sq. m]	1 / 23 [9]	1 / 23 [9]	1 / 23 [9]
Rows / FPI [FPcm]	Louvered	Louvered	Louvered
Indoor Coil—Fin Type	Rifled	Rifled	Rifled
Tube Type	0.375 [9.5]	0.375 [9.5]	0.375 [9.5]
Tube Size in. [mm]	26.67 [2.48]	26.67 [2.48]	26.67 [2.48]
Face Area sq. ft. [sq. m]	14 / 15 [6]	4 / 15 [6]	4 / 15 [6]
Rows / FPI [FPcm]	TX Valves	TX Valves	TX Valves
Refrigerant Control	1/1 [25.4]	1/1 [25.4]	1/1 [25.4]
Drain Connection No./Size in. [mm]	Propeller	Propeller	Propeller
Outdoor Fan—Type	6/24 [609.6]	6/24 [609.6]	6/24 [609.6]
No. Used/Diameter in. [mm]	Direct/1	Direct/1	Direct/1
Drive Type/No. Speeds	19800 [9344]	19800 [9344]	19800 [9344]
CFM [L/s]	6 at 1/3 HP	6 at 1/3 HP	6 at 1/3 HP
No. Motors/HP	1075	1075	1075
Motor RPM	FC Centrifugal	FC Centrifugal	FC Centrifugal
Indoor Fan—Type	2/18x9 [457x229]	2/18x9 [457x229]	2/18x9 [457x229]
No. Used/Diameter in. [mm]	Belt (Adjustable)	Belt (Adjustable)	Belt (Adjustable)
Drive Type	Single / Multiple	Single	Single
No. Speeds (Standard / VFD)	1	1	1
No. Motors	7 1/2	5	7 1/2
Motor HP	1725	1725	1725
Motor RPM	184	184	213
Motor Frame Size	Disposable	Disposable	Disposable
Filter—Type	Yes	Yes	Yes
Furnished	(8)2x25x20 [51x635x508]	(8)2x25x20 [51x635x508]	(8)2x25x20 [51x635x508]
(NO.) Size Recommended in. [mm x mm x mm]	271/227 [7683/6435]	271/227 [7683/6435]	271/227 [7683/6435]
Refrigerant Charge Oz. [g] (Sys. 1/Sys. 2) [g]			
Weights			
Net Weight lbs. [kg]	2327 [1056]	2151 [976]	2189 [993]
Ship Weight lbs. [kg]	2427 [1101]	2251 [1021]	2289 [1038]

NOTES:

- Cooling Performance is rated at 95° F ambient, 80° F entering dry bulb, 67° F entering wet bulb. Gross capacity does not include the effect of fan motor heat. AHRI capacity is net and includes the effect of fan motor heat. Units are suitable for operation to ±20% of nominal cfm. Units are certified in accordance with the Unitary Air Conditioner Equipment certification program, which is based on AHRI Standard 340/360.
- EER is rated at AHRI conditions and in accordance with DOE test procedures.
- Integrated Energy Efficiency Ratio (IEER) is rated in accordance with AHRI Standard 340/360.
- Outdoor Sound Rating shown is tested in accordance with AHRI Standard 270.
- 25 Ton Model is outside the scope of AHRI Standard 340/360.

[] Designates Metric Conversions



NOM. SIZES 15-25 TONS [52.8-87.9 kW] MODELS

Model RLNL- Series	H300CR	H300CS	H300DR	H300DS
Model RLNL- Series (with VFD)				
Cooling Performance¹				
Gross Cooling Capacity Btu [kW]	312000 [88.74]	312000 [88.74]	312000 [88.74]	312,000 [88.74]
EER/SEER ²	11/NA	11/NA	11/NA	11/NA
Nominal CFM/AHRI Rated CFM [L/s]	10000/9475 [4719/4471]	10000/9475 [4719/4471]	10000/9475 [4719/4471]	10000/9475 [4719/4471]
AHRI Net Cooling Capacity Btu [kW]	286,000 [81.34]	286,000 [81.34]	286,000 [81.34]	286,000 [81.34]
Net Sensible Capacity Btu [kW]	206,100 [58.62]	206,100 [58.62]	206,100 [58.62]	206,100 [58.62]
Net Latent Capacity Btu [kW]	79,900 [22.72]	79,900 [22.72]	79,900 [22.72]	79,900 [22.72]
IEER ³	13.2	13.2	13.2	13.2
Net System Power [kW]	26	26	26	26
Compressor				
No./Type	2/Scroll	2/Scroll	2/Scroll	2/Scroll
Outdoor Sound Rating (dB)⁴				
	92	92	92	92
Outdoor Coil—Fin Type				
Tube Type	Louvered	Louvered	Louvered	Louvered
Tube Size in. [mm] OD	Rifled	Rifled	Rifled	Rifled
Tube Size in. [mm] OD	0.375 [9.5]	0.375 [9.5]	0.375 [9.5]	0.375 [9.5]
Face Area sq. ft. [sq. m]	53.3 [4.95]	53.3 [4.95]	53.3 [4.95]	53.3 [4.95]
Rows / FPI [FPcm]	53.3 [4.95]	2 / 22 [9]	2 / 22 [9]	2 / 22 [9]
Indoor Coil—Fin Type				
Tube Type	Louvered	Louvered	Louvered	Louvered
Tube Type	Rifled	Rifled	Rifled	Rifled
Tube Size in. [mm]	0.375 [9.5]	0.375 [9.5]	0.375 [9.5]	0.375 [9.5]
Face Area sq. ft. [sq. m]	26.67 [2.48]	26.67 [2.48]	26.67 [2.48]	26.67 [2.48]
Rows / FPI [FPcm]	4 / 15 [6]	4 / 15 [6]	4 / 15 [6]	4 / 15 [6]
Refrigerant Control	TX Valves	TX Valves	TX Valves	TX Valves
Drain Connection No./Size in. [mm]	1/1 [25.4]	1/1 [25.4]	1/1 [25.4]	1/1 [25.4]
Outdoor Fan—Type				
Propeller	Propeller	Propeller	Propeller	Propeller
No. Used/Diameter in. [mm]	6/24 [609.6]	6/24 [609.6]	6/24 [609.6]	6/24 [609.6]
Drive Type/No. Speeds	Direct/1	Direct/1	Direct/1	Direct/1
CFM [L/s]	19800 [9344]	19800 [9344]	19800 [9344]	19800 [9344]
No. Motors/HP	6 at 1/3 HP	6 at 1/3 HP	6 at 1/3 HP	6 at 1/3 HP
Motor RPM	1075	1075	1075	1075
Indoor Fan—Type				
FC Centrifugal	FC Centrifugal	FC Centrifugal	FC Centrifugal	FC Centrifugal
No. Used/Diameter in. [mm]	2/18x9 [457x229]	2/18x9 [457x229]	2/18x9 [457x229]	2/18x9 [457x229]
Drive Type	Belt (Adjustable)	Belt (Adjustable)	Belt (Adjustable)	Belt (Adjustable)
No. Speeds (Standard / VFD)	Single / Multiple	Single / Multiple	Single / Multiple	Single / Multiple
No. Motors	1	1	1	1
Motor HP	7 1/2	10	7 1/2	10
Motor RPM	1725	1725	1725	1725
Motor Frame Size	213	215	213	215
Filter—Type				
Disposable	Disposable	Disposable	Disposable	Disposable
Furnished	Yes	Yes	Yes	Yes
(NO.) Size Recommended in. [mm x mm x mm]	(8)2x25x20 [51x635x508]	(8)2x25x20 [51x635x508]	(8)2x25x20 [51x635x508]	(8)2x25x20 [51x635x508]
Refrigerant Charge Oz. [g] (Sys. 1/Sys. 2) [g]				
	339/357 [9611/10121]	339/357 [9611/10121]	339/357 [9611/10121]	339/357 [9611/10121]
Weights				
Net Weight lbs. [kg]	2250 [1021]	2261 [1026]	2250 [1021]	2261 [1026]
Ship Weight lbs. [kg]	2376 [1078]	2387 [1083]	2376 [1078]	2387 [1083]

NOTES:

- Cooling Performance is rated at 95° F ambient, 80° F entering dry bulb, 67° F entering wet bulb. Gross capacity does not include the effect of fan motor heat. AHRI capacity is net and includes the effect of fan motor heat. Units are suitable for operation to $\pm 20\%$ of nominal cfm. Units are certified in accordance with the Unitary Air Conditioner Equipment certification program, which is based on AHRI Standard 340/360.
- EER is rated at AHRI conditions and in accordance with DOE test procedures.
- Integrated Energy Efficiency Ratio (IEER) is rated in accordance with AHRI Standard 340/360.
- Outdoor Sound Rating shown is tested in accordance with AHRI Standard 270.
- 25 Ton Model is outside the scope of AHRI Standard 340/360.

[] Designates Metric Conversions



GROSS SYSTEMS PERFORMANCE DATA—C/H180

		ENTERING INDOOR AIR @ 80°F [26.7°C] dbE ①									
wbE		71°F [21.7°C]			67°F [19.4°C]			63°F [17.2°C]			
CFM [L/s]		7200 [3398]	5900 [2784]	4800 [2265]	7200 [3398]	5900 [2784]	4800 [2265]	7200 [3398]	5900 [2784]	4800 [2265]	
DR ①		.04	.08	.13	.04	.08	.13	.04	.08	.13	
OUTDOOR DRY BULB TEMPERATURE °F [°C]	75 [23.9]	Total BTUH [kW] Sens BTUH [kW] Power	226.5 [66.4] 148.8 [43.6] 12.6	217.8 [63.8] 126.2 [37.0] 12.3	210.4 [61.7] 108.5 [31.8] 12.1	214.3 [62.8] 174.1 [51.0] 12.4	206.0 [60.4] 149.6 [43.9] 12.2	199.0 [58.3] 130.2 [38.2] 12.0	206.3 [60.5] 193.4 [56.7] 12.2	198.4 [58.1] 167.5 [49.1] 12.0	191.7 [56.2] 146.8 [43.0] 11.8
	80 [26.7]	Total BTUH [kW] Sens BTUH [kW] Power	222.2 [65.1] 146.6 [43.0] 13.1	213.6 [62.6] 124.3 [36.4] 12.9	206.4 [60.5] 106.9 [31.3] 12.7	209.9 [61.5] 171.9 [50.4] 13.0	201.8 [59.1] 147.8 [43.3] 12.7	195.0 [57.1] 128.7 [37.7] 12.5	202.0 [59.2] 191.3 [56.1] 12.8	194.2 [56.9] 165.7 [48.6] 12.6	187.6 [55.0] 145.3 [42.6] 12.4
	85 [29.4]	Total BTUH [kW] Sens BTUH [kW] Power	217.5 [63.7] 144.1 [42.2] 13.8	209.1 [61.3] 122.3 [35.9] 13.5	202.0 [59.2] 105.2 [30.8] 13.3	205.3 [60.2] 169.5 [49.7] 13.6	197.3 [57.8] 145.7 [42.7] 13.4	190.7 [55.9] 127.0 [37.2] 13.1	197.3 [57.8] 188.8 [55.3] 13.5	189.7 [55.6] 163.6 [48.0] 13.2	183.3 [53.7] 143.5 [42.1] 13.0
	90 [32.2]	Total BTUH [kW] Sens BTUH [kW] Power	212.5 [62.3] 141.4 [41.5] 14.5	204.3 [59.9] 120.0 [35.2] 14.2	197.4 [57.9] 103.3 [30.3] 14.0	200.2 [58.7] 166.7 [48.9] 14.3	192.5 [56.4] 143.5 [42.1] 14.0	186.0 [54.5] 125.1 [36.7] 13.8	192.3 [56.4] 186.2 [54.6] 14.2	184.9 [54.2] 161.4 [47.3] 13.9	178.6 [52.3] 141.6 [41.5] 13.7
	95 [35]	Total BTUH [kW] Sens BTUH [kW] Power	207.2 [60.7] 138.5 [40.6] 15.2	199.2 [58.4] 117.6 [34.5] 14.9	192.4 [56.4] 101.2 [29.7] 14.7	194.9 [57.1] 163.9 [48.0] 15.1	187.4 [54.9] 141.1 [41.4] 14.8	181.0 [53.0] 123.0 [36.1] 14.5	187.0 [54.8] 183.3 [53.7] 14.9	179.8 [52.7] 159.0 [46.6] 14.6	173.7 [50.9] 139.6 [40.9] 14.4
	100 [37.8]	Total BTUH [kW] Sens BTUH [kW] Power	201.5 [59.1] 135.4 [39.7] 16.0	193.7 [56.8] 115.0 [33.7] 15.7	187.2 [54.9] 99.1 [29.1] 15.4	189.2 [55.4] 160.7 [47.1] 15.9	181.9 [53.3] 138.4 [40.6] 15.6	175.8 [51.5] 120.8 [35.4] 15.3	181.3 [53.1] 180.1 [52.8] 15.7	174.3 [51.1] 156.3 [45.8] 15.4	168.4 [49.4] 137.3 [40.2] 15.1
	105 [40.6]	Total BTUH [kW] Sens BTUH [kW] Power	195.5 [57.3] 132.0 [38.7] 16.9	188.0 [55.1] 112.2 [32.9] 16.5	181.6 [53.2] 96.6 [28.3] 16.3	183.2 [53.7] 157.3 [46.1] 16.7	176.2 [51.6] 135.6 [39.8] 16.4	170.2 [49.9] 118.3 [34.7] 16.1	175.3 [51.4] 175.3 [51.4] 16.5	168.5 [49.4] 153.4 [45.0] 16.2	162.8 [47.7] 134.8 [39.5] 16.0
	110 [43.3]	Total BTUH [kW] Sens BTUH [kW] Power	189.2 [55.4] 128.4 [37.6] 17.8	181.9 [53.3] 109.1 [32.0] 17.4	175.7 [51.5] 93.9 [27.5] 17.1	176.9 [51.8] 153.7 [45.1] 17.6	170.1 [49.9] 132.6 [38.9] 17.3	164.3 [48.2] 115.8 [33.9] 17.0	169.0 [49.5] 169.0 [49.5] 17.5	162.5 [47.6] 150.5 [44.1] 17.1	156.9 [46.0] 132.3 [38.8] 16.8
	115 [46.1]	Total BTUH [kW] Sens BTUH [kW] Power	182.5 [53.5] 124.5 [36.5] 18.7	175.5 [51.4] 105.9 [31.0] 18.4	169.5 [49.7] 91.2 [26.7] 18.1	170.2 [49.9] 149.9 [43.9] 18.6	163.7 [48.0] 129.4 [37.9] 18.2	158.1 [46.3] 113.0 [33.1] 17.9	162.3 [47.6] 162.3 [47.6] 18.4	156.0 [45.7] 147.2 [43.2] 18.1	150.8 [44.2] 129.6 [38.0] 17.8

GROSS SYSTEMS PERFORMANCE DATA—C/H210

		ENTERING INDOOR AIR @ 80°F [26.7°C] dbE ①									
wbE		71°F [21.7°C]			67°F [19.4°C]			63°F [17.2°C]			
CFM [L/s]		8400 [3964]	7025 [3315]	5600 [2643]	8400 [3964]	7025 [3315]	5600 [2643]	8400 [3964]	7025 [3315]	5600 [2643]	
DR ①		.06	.09	.13	.06	.09	.13	.06	.09	.13	
OUTDOOR DRY BULB TEMPERATURE °F [°C]	75 [23.9]	Total BTUH [kW] Sens BTUH [kW] Power	258.4 [75.7] 193.9 [56.8] 13.0	249.5 [73.1] 168.8 [49.5] 12.8	240.3 [70.4] 144.5 [42.4] 12.5	244.1 [71.5] 224.6 [65.8] 12.8	235.7 [69.1] 197.4 [57.9] 12.6	227.0 [66.5] 170.8 [50.1] 12.4	231.9 [68.0] 231.9 [68.0] 12.7	223.9 [65.6] 217.1 [63.6] 12.4	215.7 [63.2] 189.1 [55.4] 12.2
	80 [26.7]	Total BTUH [kW] Sens BTUH [kW] Power	252.7 [74.1] 182.3 [53.4] 13.6	244.0 [71.5] 158.3 [46.4] 13.4	235.0 [68.9] 135.2 [39.6] 13.1	238.4 [69.9] 212.9 [62.4] 13.4	230.2 [67.5] 186.9 [54.8] 13.2	221.7 [65.0] 161.5 [47.3] 13.0	226.2 [66.3] 226.2 [66.3] 13.3	218.4 [64.0] 206.6 [60.6] 13.0	210.4 [61.7] 179.8 [52.7] 12.8
	85 [29.4]	Total BTUH [kW] Sens BTUH [kW] Power	246.7 [72.3] 171.9 [50.4] 14.2	238.2 [69.8] 149.0 [43.7] 14.0	229.4 [67.2] 126.9 [37.2] 13.7	232.4 [68.1] 202.7 [59.4] 14.1	224.4 [65.8] 177.7 [52.1] 13.8	216.1 [63.3] 153.4 [45.0] 13.6	220.2 [64.5] 220.2 [64.5] 13.9	212.6 [62.3] 197.4 [57.9] 13.7	204.8 [60.0] 171.7 [50.3] 13.4
	90 [32.2]	Total BTUH [kW] Sens BTUH [kW] Power	240.4 [70.5] 162.9 [47.8] 14.9	232.1 [68.0] 141.0 [41.3] 14.7	223.5 [65.5] 119.9 [35.1] 14.4	226.1 [66.3] 193.6 [56.7] 14.8	218.3 [64.0] 169.6 [49.7] 14.5	210.3 [61.6] 146.3 [42.9] 14.3	213.9 [62.7] 213.9 [62.7] 14.6	206.5 [60.5] 189.3 [55.5] 14.4	198.9 [58.3] 164.5 [48.2] 14.1
	95 [35]	Total BTUH [kW] Sens BTUH [kW] Power	233.8 [68.5] 155.3 [45.5] 15.7	225.7 [66.1] 134.2 [39.3] 15.4	217.4 [63.7] 114.0 [33.4] 15.1	219.5 [64.3] 186.0 [54.5] 15.5	212.0 [62.1] 162.9 [47.8] 15.2	204.1 [59.8] 140.3 [41.1] 15.0	207.3 [60.8] 207.0 [60.7] 15.3	200.2 [58.7] 182.6 [53.5] 15.1	192.8 [56.5] 158.6 [46.5] 14.8
	100 [37.8]	Total BTUH [kW] Sens BTUH [kW] Power	226.9 [66.5] 149.0 [43.7] 16.5	219.1 [64.2] 128.7 [37.7] 16.2	211.0 [61.8] 109.2 [32.0] 15.9	212.6 [62.3] 179.6 [52.6] 16.3	205.3 [60.2] 157.3 [46.1] 16.0	197.7 [57.9] 135.5 [39.7] 15.7	200.4 [58.7] 200.4 [58.7] 16.1	193.5 [56.7] 177.0 [51.9] 15.9	186.4 [54.6] 153.8 [45.1] 15.6
	105 [40.6]	Total BTUH [kW] Sens BTUH [kW] Power	219.7 [64.4] 143.9 [42.2] 17.3	212.1 [62.2] 124.3 [36.4] 17.0	204.3 [59.9] 105.5 [30.9] 16.7	205.4 [60.2] 174.6 [51.2] 17.1	198.3 [58.1] 152.9 [44.8] 16.8	191.0 [56.0] 131.8 [38.6] 16.5	193.2 [56.6] 193.2 [56.6] 17.0	186.5 [54.7] 172.7 [50.6] 16.7	179.7 [52.7] 150.2 [44.0] 16.4
	110 [43.3]	Total BTUH [kW] Sens BTUH [kW] Power	212.2 [62.2] 140.3 [41.1] 18.2	204.9 [60.1] 121.3 [35.6] 17.9	197.3 [57.8] 102.9 [30.2] 17.5	197.9 [58.0] 171.0 [50.1] 18.0	191.1 [56.0] 149.9 [43.9] 17.7	184.0 [53.9] 129.3 [37.9] 17.4	185.7 [54.4] 185.7 [54.4] 17.9	179.3 [52.5] 169.6 [49.7] 17.6	172.7 [50.6] 147.6 [43.3] 17.2
	115 [46.1]	Total BTUH [kW] Sens BTUH [kW] Power	204.4 [59.9] 138.1 [40.5] 9.1	197.3 [57.8] 119.4 [35.0] 18.8	190.1 [55.7] 101.6 [29.8] 18.5	190.1 [55.7] 168.7 [49.5] 19.0	183.5 [53.8] 148.0 [43.4] 18.6	176.8 [51.8] 127.9 [37.5] 18.3	177.9 [52.1] 177.9 [52.1] 18.8	171.8 [50.3] 167.8 [49.2] 18.5	165.4 [48.5] 146.1 [42.8] 18.1

DR —Depression ratio
dbE—Entering air dry bulb
wbE—Entering air wet bulb

Total —Total capacity x 1000 BTUH
Sens —Sensible capacity x 1000 BTUH
Power —KW input

NOTES: ① When the entering air dry bulb is other than 80°F [27°C], adjust the sensible capacity from the table by adding [1.10 x CFM x (1 - DR) x (dbE - 80)].

[] Designates Metric Conversions





GROSS SYSTEMS PERFORMANCE DATA—C/H240

wbE		ENTERING INDOOR AIR @ 80°F [26.7°C] dbE ①									
		71°F [21.7°C]			67°F [19.4°C]			63°F [17.2°C]			
CFM [L/s]		9600 [4530]	7725 [3646]	6400 [3020]	9600 [4530]	7725 [3646]	6400 [3020]	9600 [4530]	7725 [3646]	6400 [3020]	
DR ①		.06	.11	.15	.06	.11	.15	.06	.11	.15	
OUTDOOR DRY BULB TEMPERATURE °F [°C]	75 [23.9]	Total BTUH [kW] Sens BTUH [kW] Power	283.5 [83.1] 187.4 [54.9] 15.4	271.5 [79.6] 156.3 [45.8] 15.1	263.0 [77.1] 136.0 [39.9] 14.9	269.6 [79.0] 220.5 [64.6] 15.3	258.2 [75.7] 186.7 [54.7] 15.0	250.2 [73.3] 164.4 [48.2] 14.7	258.7 [75.8] 245.6 [72.0] 15.1	247.8 [72.6] 209.7 [61.5] 14.8	240.0 [70.3] 185.7 [54.4] 14.6
	80 [26.7]	Total BTUH [kW] Sens BTUH [kW] Power	280.8 [82.3] 186.4 [54.6] 16.2	269.0 [78.8] 155.6 [45.6] 15.9	260.6 [76.4] 135.4 [39.7] 15.6	267.0 [78.2] 219.6 [64.4] 16.0	255.7 [74.9] 186.0 [54.5] 15.7	247.7 [72.6] 163.8 [48.0] 15.5	256.1 [75.1] 244.7 [71.7] 15.9	245.3 [71.9] 209.0 [61.3] 15.5	237.6 [69.6] 185.2 [54.3] 15.3
	85 [29.4]	Total BTUH [kW] Sens BTUH [kW] Power	277.4 [81.3] 184.9 [54.2] 17.0	265.7 [77.9] 154.4 [45.3] 16.7	257.4 [75.4] 134.4 [39.4] 16.4	263.5 [77.2] 218.1 [63.9] 16.9	252.4 [74.0] 184.8 [54.2] 16.5	244.5 [71.7] 162.7 [47.7] 16.3	252.6 [74.0] 243.1 [71.3] 16.7	242.0 [70.9] 207.8 [60.9] 16.3	234.4 [68.7] 184.2 [54.0] 16.1
	90 [32.2]	Total BTUH [kW] Sens BTUH [kW] Power	273.1 [80.0] 182.8 [53.6] 17.9	261.6 [76.7] 152.7 [44.8] 17.5	253.4 [74.3] 132.9 [39.0] 17.3	259.3 [76.0] 216.2 [63.4] 17.7	248.3 [72.8] 183.2 [53.7] 17.4	240.6 [70.5] 161.5 [47.3] 17.1	248.4 [72.8] 241.1 [70.7] 17.6	237.9 [69.7] 206.1 [60.4] 17.2	230.5 [67.6] 182.8 [53.6] 16.9
	95 [35]	Total BTUH [kW] Sens BTUH [kW] Power	268.1 [78.6] 180.2 [52.8] 18.8	256.7 [75.2] 150.5 [44.1] 18.4	248.7 [72.9] 131.1 [38.4] 18.2	254.2 [74.5] 213.5 [62.6] 18.7	243.5 [71.4] 181.1 [53.1] 18.3	235.9 [69.1] 159.6 [46.8] 18.0	243.3 [71.3] 238.6 [69.9] 18.5	233.0 [68.3] 204.0 [59.8] 18.1	225.8 [66.2] 181.0 [53.1] 17.8
	100 [37.8]	Total BTUH [kW] Sens BTUH [kW] Power	262.2 [76.8] 177.1 [51.9] 19.8	251.1 [73.6] 148.0 [43.4] 19.4	243.3 [71.3] 129.0 [37.8] 19.1	248.3 [72.8] 210.4 [61.7] 19.6	237.8 [69.7] 178.5 [52.3] 19.2	230.4 [67.5] 157.4 [46.1] 18.9	237.4 [69.6] 235.3 [69.0] 19.5	227.4 [66.6] 201.4 [59.0] 19.1	220.3 [64.6] 178.7 [52.4] 18.8
	105 [40.6]	Total BTUH [kW] Sens BTUH [kW] Power	255.5 [74.9] 173.4 [50.8] 20.8	244.7 [71.7] 145.0 [42.5] 20.4	237.1 [69.5] 126.4 [37.1] 20.1	241.6 [70.8] 206.6 [60.6] 20.7	231.4 [67.8] 175.4 [51.4] 20.2	224.2 [65.7] 154.7 [45.3] 19.9	230.7 [67.6] 230.7 [67.6] 20.5	221.0 [64.8] 198.4 [58.2] 20.1	214.1 [62.7] 176.2 [51.6] 19.8
	110 [43.3]	Total BTUH [kW] Sens BTUH [kW] Power	248.0 [72.7] 169.2 [49.6] 21.9	237.5 [69.6] 141.5 [41.5] 21.5	230.1 [67.4] 123.4 [36.2] 21.1	234.1 [68.6] 202.4 [59.3] 21.7	224.2 [65.7] 171.9 [50.4] 21.3	217.2 [63.7] 151.7 [44.5] 21.0	223.2 [65.4] 223.2 [65.4] 21.6	213.8 [62.7] 194.9 [57.1] 21.1	207.1 [60.7] 173.1 [50.7] 20.8
	115 [46.1]	Total BTUH [kW] Sens BTUH [kW] Power	239.6 [70.2] 164.3 [48.2] 23.1	229.5 [67.3] 137.5 [40.3] 22.6	222.3 [65.1] 119.9 [35.1] 22.2	225.8 [66.2] 197.7 [58.0] 22.9	216.2 [63.4] 168.0 [49.2] 22.4	209.5 [61.4] 148.4 [43.5] 22.1	214.9 [63.0] 214.9 [63.0] 22.7	205.8 [60.3] 191.0 [56.0] 22.2	199.4 [58.4] 169.8 [49.8] 21.9

DR —Depression ratio
dbE —Entering air dry bulb
wbE—Entering air wet bulb

Total —Total capacity x 1000 BTUH
Sens —Sensible capacity x 1000 BTUH
Power —KW input

NOTES: ① When the entering air dry bulb is other than 80°F [27°C], adjust the sensible capacity from the table by adding [1.10 x CFM x (1 – DR) x (dbE – 80)].

[] Designates Metric Conversions





GROSS SYSTEMS PERFORMANCE DATA—RLNL-C241

		ENTERING INDOOR AIR @ 80°F [26.7°C] dbE ①									
wbE		71°F [21.7°C]			67°F [19.4°C]			63°F [17.2°C]			
CFM [L/s]		8113 [3829]	7375 [3481]	6269 [2959]	8113 [3829]	7375 [3481]	6269 [2959]	8113 [3829]	7375 [3481]	6269 [2959]	
DR ①		.11	.09	.06	.11	.09	.06	.11	.09	.06	
OUTDOOR DRY BULB TEMPERATURE [°C]	75 [23.9]	Total BTUH [kW]	245.4 [71.9]	241.0 [70.6]	234.4 [68.7]	245.4 [71.9]	241.0 [70.6]	234.4 [68.7]	245.4 [71.9]	241.0 [70.6]	234.4 [68.7]
		Sens BTUH [kW]	186.3 [54.6]	178.0 [52.2]	165.5 [48.5]	186.3 [54.6]	178.0 [52.2]	165.5 [48.5]	186.3 [54.6]	178.0 [52.2]	165.5 [48.5]
		Power	16.5	16.4	16.2	16.5	16.4	16.2	16.5	16.4	16.2
	80 [26.7]	Total BTUH [kW]	245.4 [71.9]	241.0 [70.6]	234.4 [68.7]	245.4 [71.9]	241.0 [70.6]	234.4 [68.7]	245.4 [71.9]	241.0 [70.6]	234.4 [68.7]
		Sens BTUH [kW]	186.3 [54.6]	178.0 [52.2]	165.5 [48.5]	186.3 [54.6]	178.0 [52.2]	165.5 [48.5]	186.3 [54.6]	178.0 [52.2]	165.5 [48.5]
		Power	16.5	16.4	16.2	16.5	16.4	16.2	16.5	16.4	16.2
	85 [29.4]	Total BTUH [kW]	245.4 [71.9]	241.0 [70.6]	234.4 [68.7]	245.4 [71.9]	241.0 [70.6]	234.4 [68.7]	245.4 [71.9]	241.0 [70.6]	234.4 [68.7]
		Sens BTUH [kW]	186.3 [54.6]	178.0 [52.2]	165.5 [48.5]	186.3 [54.6]	178.0 [52.2]	165.5 [48.5]	186.3 [54.6]	178.0 [52.2]	165.5 [48.5]
		Power	16.5	16.4	16.2	16.5	16.4	16.2	16.5	16.4	16.2
	90 [32.2]	Total BTUH [kW]	245.4 [71.9]	241.0 [70.6]	234.4 [68.7]	245.4 [71.9]	241.0 [70.6]	234.4 [68.7]	245.4 [71.9]	241.0 [70.6]	234.4 [68.7]
		Sens BTUH [kW]	186.3 [54.6]	178.0 [52.2]	165.5 [48.5]	186.3 [54.6]	178.0 [52.2]	165.5 [48.5]	186.3 [54.6]	178.0 [52.2]	165.5 [48.5]
		Power	16.5	16.4	16.2	16.5	16.4	16.2	16.5	16.4	16.2
95 [35]	Total BTUH [kW]	245.4 [71.9]	241.0 [70.6]	234.4 [68.7]	245.4 [71.9]	241.0 [70.6]	234.4 [68.7]	245.4 [71.9]	241.0 [70.6]	234.4 [68.7]	
	Sens BTUH [kW]	186.3 [54.6]	178.0 [52.2]	165.5 [48.5]	186.3 [54.6]	178.0 [52.2]	165.5 [48.5]	186.3 [54.6]	178.0 [52.2]	165.5 [48.5]	
	Power	16.5	16.4	16.2	16.5	16.4	16.2	16.5	16.4	16.2	
100 [37.8]	Total BTUH [kW]	245.4 [71.9]	241.0 [70.6]	234.4 [68.7]	245.4 [71.9]	241.0 [70.6]	234.4 [68.7]	245.4 [71.9]	241.0 [70.6]	234.4 [68.7]	
	Sens BTUH [kW]	186.3 [54.6]	178.0 [52.2]	165.5 [48.5]	186.3 [54.6]	178.0 [52.2]	165.5 [48.5]	186.3 [54.6]	178.0 [52.2]	165.5 [48.5]	
	Power	16.5	16.4	16.2	16.5	16.4	16.2	16.5	16.4	16.2	
105 [40.6]	Total BTUH [kW]	245.4 [71.9]	241.0 [70.6]	234.4 [68.7]	245.4 [71.9]	241.0 [70.6]	234.4 [68.7]	245.4 [71.9]	241.0 [70.6]	234.4 [68.7]	
	Sens BTUH [kW]	186.3 [54.6]	178.0 [52.2]	165.5 [48.5]	186.3 [54.6]	178.0 [52.2]	165.5 [48.5]	186.3 [54.6]	178.0 [52.2]	165.5 [48.5]	
	Power	16.5	16.4	16.2	16.5	16.4	16.2	16.5	16.4	16.2	
110 [43.3]	Total BTUH [kW]	245.4 [71.9]	241.0 [70.6]	234.4 [68.7]	245.4 [71.9]	241.0 [70.6]	234.4 [68.7]	245.4 [71.9]	241.0 [70.6]	234.4 [68.7]	
	Sens BTUH [kW]	186.3 [54.6]	178.0 [52.2]	165.5 [48.5]	186.3 [54.6]	178.0 [52.2]	165.5 [48.5]	186.3 [54.6]	178.0 [52.2]	165.5 [48.5]	
	Power	16.5	16.4	16.2	16.5	16.4	16.2	16.5	16.4	16.2	
115 [46.1]	Total BTUH [kW]	245.4 [71.9]	241.0 [70.6]	234.4 [68.7]	245.4 [71.9]	241.0 [70.6]	234.4 [68.7]	245.4 [71.9]	241.0 [70.6]	234.4 [68.7]	
	Sens BTUH [kW]	186.3 [54.6]	178.0 [52.2]	165.5 [48.5]	186.3 [54.6]	178.0 [52.2]	165.5 [48.5]	186.3 [54.6]	178.0 [52.2]	165.5 [48.5]	
	Power	16.5	16.4	16.2	16.5	16.4	16.2	16.5	16.4	16.2	
120 [48.9]	Total BTUH [kW]	245.4 [71.9]	241.0 [70.6]	234.4 [68.7]	245.4 [71.9]	241.0 [70.6]	234.4 [68.7]	245.4 [71.9]	241.0 [70.6]	234.4 [68.7]	
	Sens BTUH [kW]	186.3 [54.6]	178.0 [52.2]	165.5 [48.5]	186.3 [54.6]	178.0 [52.2]	165.5 [48.5]	186.3 [54.6]	178.0 [52.2]	165.5 [48.5]	
	Power	16.5	16.4	16.2	16.5	16.4	16.2	16.5	16.4	16.2	
125 [51.7]	Total BTUH [kW]	245.4 [71.9]	241.0 [70.6]	234.4 [68.7]	245.4 [71.9]	241.0 [70.6]	234.4 [68.7]	245.4 [71.9]	241.0 [70.6]	234.4 [68.7]	
	Sens BTUH [kW]	186.3 [54.6]	178.0 [52.2]	165.5 [48.5]	186.3 [54.6]	178.0 [52.2]	165.5 [48.5]	186.3 [54.6]	178.0 [52.2]	165.5 [48.5]	
	Power	16.5	16.4	16.2	16.5	16.4	16.2	16.5	16.4	16.2	

DR —Depression ratio
dbE —Entering air dry bulb
wbE —Entering air wet bulb

Total —Total capacity x 1000 BTUH
Sens —Sensible capacity x 1000 BTUH
Power —KW input

NOTES: ① When the entering air dry bulb is other than 80°F [27°C], adjust the sensible capacity from the table by adding [1.10 x CFM x (1 - DR) x (dbE - 80)].

[] Designates Metric Conversions





GROSS SYSTEMS PERFORMANCE DATA—H300

		ENTERING INDOOR AIR @ 80°F [26.7°C] dbE ①									
wbE		71°F [21.7°C]			67°F [19.4°C]			63°F [17.2°C]			
CFM [L/s]		12000 [5663]	9475 [4472]	8000 [3776]	12000 [5663]	9475 [4472]	8000 [3776]	12000 [5663]	9475 [4472]	8000 [3776]	
DR ①		.02	.08	.11	.02	.08	.11	.02	.08	.11	
OUTDOOR DRY BULB TEMPERATURE °F [°C]	75 [23.9]	Total BTUH [kW] Sens BTUH [kW] Power	376.4 [110.3] 251.6 [73.7] 20.8	359.0 [105.2] 206.4 [60.5] 20.3	348.9 [102.3] 182.0 [53.3] 20.0	358.0 [104.9] 294.2 [86.2] 20.5	341.5 [100.1] 245.2 [71.9] 20.0	331.8 [97.2] 218.4 [64.0] 19.7	347.0 [101.7] 326.2 [95.6] 20.2	330.9 [97.0] 274.0 [80.3] 19.7	321.6 [94.3] 245.5 [72.0] 19.5
	80 [26.7]	Total BTUH [kW] Sens BTUH [kW] Power	369.9 [108.4] 248.1 [72.7] 21.7	352.8 [103.4] 203.6 [59.7] 21.2	342.8 [100.5] 179.5 [52.6] 21.0	351.5 [103.0] 290.8 [85.2] 21.4	335.2 [98.2] 242.3 [71.0] 21.0	325.7 [95.5] 215.9 [63.3] 20.7	340.4 [99.8] 322.6 [94.6] 21.2	324.6 [95.1] 271.1 [79.5] 20.7	315.5 [92.5] 243.0 [71.2] 20.4
	85 [29.4]	Total BTUH [kW] Sens BTUH [kW] Power	362.5 [106.2] 244.2 [71.6] 22.8	345.7 [101.3] 200.4 [58.7] 22.2	335.9 [98.4] 176.8 [51.8] 21.9	344.1 [100.8] 286.8 [84.1] 22.5	328.2 [96.2] 239.2 [70.1] 22.0	318.9 [93.5] 213.2 [62.5] 21.7	333.0 [97.6] 318.6 [93.4] 22.2	317.6 [93.1] 268.0 [78.6] 21.7	308.6 [90.4] 240.2 [70.4] 21.4
	90 [32.2]	Total BTUH [kW] Sens BTUH [kW] Power	354.3 [103.8] 239.8 [70.3] 23.9	338.0 [99.1] 197.0 [57.7] 23.3	328.4 [96.2] 173.8 [50.9] 23.0	335.9 [98.4] 282.4 [82.8] 23.6	320.4 [93.9] 235.7 [69.1] 23.0	311.3 [91.2] 210.1 [61.6] 22.7	324.9 [95.2] 314.4 [92.2] 23.3	309.8 [90.8] 264.5 [77.5] 22.7	301.1 [88.2] 237.2 [69.5] 22.4
	95 [35]	Total BTUH [kW] Sens BTUH [kW] Power	345.4 [101.2] 235.2 [68.9] 25.0	329.4 [96.5] 193.2 [56.6] 24.4	320.1 [93.8] 170.5 [50.0] 24.1	327.0 [95.8] 277.8 [81.4] 24.7	311.9 [91.4] 232.0 [68.0] 24.1	303.1 [88.8] 207.0 [60.7] 23.8	315.9 [92.6] 309.7 [90.8] 24.4	301.3 [88.3] 260.8 [76.4] 23.9	292.8 [85.8] 234.0 [68.6] 23.5
	100 [37.8]	Total BTUH [kW] Sens BTUH [kW] Power	335.7 [98.4] 230.3 [67.5] 26.2	320.2 [93.8] 189.3 [55.5] 25.6	311.1 [91.2] 167.1 [49.0] 25.3	317.3 [93.0] 272.9 [80.0] 25.9	302.6 [88.7] 228.0 [66.8] 25.3	294.1 [86.2] 203.6 [59.7] 25.0	306.2 [89.7] 304.7 [89.3] 25.6	292.1 [85.6] 256.9 [75.3] 25.1	283.8 [83.2] 230.5 [67.6] 24.7
	105 [40.6]	Total BTUH [kW] Sens BTUH [kW] Power	325.2 [95.3] 224.9 [65.9] 27.5	310.2 [90.9] 185.0 [54.2] 26.9	301.4 [88.3] 163.4 [47.9] 26.5	306.8 [89.9] 267.5 [78.4] 27.2	292.6 [85.8] 223.7 [65.6] 26.6	284.3 [83.3] 199.8 [58.6] 26.2	295.7 [86.7] 295.7 [86.7] 26.9	282.0 [82.6] 252.5 [74.0] 26.3	274.1 [80.3] 226.8 [66.5] 25.9
	110 [43.3]	Total BTUH [kW] Sens BTUH [kW] Power	313.9 [92.0] 219.3 [64.3] 28.9	299.4 [87.7] 180.5 [52.9] 28.2	290.9 [85.3] 159.5 [46.8] 27.8	295.5 [86.6] 261.9 [76.8] 28.6	281.9 [82.6] 219.3 [64.3] 27.9	273.9 [80.3] 195.9 [57.4] 27.5	284.4 [83.3] 284.4 [83.4] 28.3	271.3 [79.5] 248.1 [72.7] 27.6	263.6 [77.3] 222.9 [65.3] 27.2
	115 [46.1]	Total BTUH [kW] Sens BTUH [kW] Power	301.8 [88.4] 213.2 [62.5] 30.3	287.9 [84.4] 175.7 [51.5] 29.6	279.7 [82.0] 155.3 [45.5] 29.2	283.4 [83.1] 255.8 [75.0] 30.0	270.4 [79.2] 214.5 [62.9] 29.3	262.7 [77.0] 191.8 [56.2] 28.9	272.4 [79.8] 272.4 [79.8] 29.7	259.8 [76.1] 243.3 [71.3] 29.0	252.4 [74.0] 218.8 [64.1] 28.6

DR —Depression ratio
dbE —Entering air dry bulb
wbE—Entering air wet bulb

Total —Total capacity x 1000 BTUH
Sens —Sensible capacity x 1000 BTUH
Power —KW input

NOTES: ① When the entering air dry bulb is other than 80°F [27°C], adjust the sensible capacity from the table by adding [1.10 x CFM x (1 – DR) x (dbE – 80)].

[] Designates Metric Conversions



AIRFLOW PERFORMANCE — 17.5 TON [61.5 kW]—SIDEFLOW

Air Flow CFM [L/s]	Capacity 17.5 Ton [61.5 kW] Voltage 208/230, 460, 575 — 3 Phase																			
	External Static Pressure—Inches of Water [kPa]																			
	0.1 [0.02]	0.2 [0.05]	0.3 [0.07]	0.4 [0.10]	0.5 [0.12]	0.6 [0.15]	0.7 [0.17]	0.8 [0.20]	0.9 [0.22]	1.0 [0.25]	1.1 [0.27]	1.2 [0.30]	1.3 [0.32]	1.4 [0.35]	1.5 [0.37]	1.6 [0.40]	1.7 [0.42]	1.8 [0.45]	1.9 [0.47]	2.0 [0.50]
5600 [2643]	—	—	—	—	—	—	—	—	—	—	—	—	—	—	—	—	—	—	—	—
5800 [2737]	—	—	—	—	—	—	—	—	—	—	—	—	—	—	—	—	—	—	—	—
6000 [2831]	—	—	—	—	—	—	—	—	—	—	—	—	—	—	—	—	—	—	—	—
6200 [2926]	—	—	—	—	—	—	—	—	—	—	—	—	—	—	—	—	—	—	—	—
6400 [3020]	—	—	—	—	—	—	—	—	—	—	—	—	—	—	—	—	—	—	—	—
6600 [3114]	—	—	—	—	—	—	—	—	—	—	—	—	—	—	—	—	—	—	—	—
6800 [3209]	—	—	—	—	—	—	—	—	—	—	—	—	—	—	—	—	—	—	—	—
7000 [3303]	610	2064	634	2203	657	2345	681	2491	703	2640	726	2791	748	2946	768	3104	791	3266	811	3430
7200 [3398]	624	2223	648	2364	671	2508	693	2656	716	2807	738	2960	759	3117	780	3277	801	3440	822	3607
7400 [3492]	639	2392	662	2536	684	2682	707	2831	728	2984	750	3139	771	3298	792	3460	811	3365	831	3565
7600 [3586]	653	2572	676	2717	698	2866	720	3017	742	3171	763	3329	783	3490	803	3654	823	3821	843	3991
7800 [3681]	669	2762	691	2910	713	3060	734	3213	755	3369	775	3529	796	3692	816	3919	837	4199	857	4522
8000 [3775]	684	2963	706	3112	727	3264	748	3419	769	3578	789	3739	808	3904	828	4072	847	4243	865	4417
8200 [3869]	700	3174	721	3325	742	3479	762	3636	783	3796	802	3960	821	4127	840	4296	859	4469	877	4645
8400 [3964]	716	3395	737	3548	757	3704	777	3863	797	4026	816	4191	835	4359	853	4531	871	4706	889	4884

NOTE: L—Drive left of bold line, M—Drive right of bold line.

Drive Package	L, R						M, S					
Motor H.P. [W]	3.0 [2237.1]						5.0 [3728.5]					
Blower Sheave	GK100H						CK105H					
Motor Sheave	1VP-44						1VP-56					
Turns Open	1	2	3	4	5	6	1	2	3	4	5	6
RPM	763	731	699	666	633	601	939	909	879	845	814	781

NOTES: 1. Factory sheave settings are shown in bold type.
2. Do not set motor sheave below minimum turns open shown.

3. Re-adjustment of sheave required to achieve rated airflow at AHR minimum External Static Pressure.
4. Drive data shown is for horizontal airflow with dry coil. Add component resistance (below) to duct resistance to determine total External Static Pressure.

COMPONENT AIR RESISTANCE — 17.5 TON [61.5 kW]

CFM [L/s]	Resistance — Inches of Water [kPa]																	
	5600 [2643]	5800 [2737]	6000 [2831]	6200 [2926]	6400 [3020]	6600 [3114]	6800 [3209]	7000 [3303]	7200 [3398]	7400 [3492]	7600 [3586]	7800 [3681]	8000 [3775]	8200 [3869]	8400 [3964]			
Wet Coil	0.06 [0.01]	0.07 [0.02]	0.08 [0.02]	0.09 [0.02]	0.10 [0.02]	0.11 [0.03]	0.12 [0.03]	0.13 [0.03]	0.14 [0.03]	0.15 [0.04]	0.16 [0.04]	0.17 [0.04]	0.18 [0.04]	0.19 [0.04]	0.20 [0.05]			
Downflow	0.05 [0.01]	0.05 [0.01]	0.05 [0.01]	0.05 [0.01]	0.05 [0.01]	0.06 [0.01]	0.06 [0.01]	0.06 [0.01]	0.06 [0.01]	0.07 [0.01]	0.07 [0.01]	0.07 [0.01]	0.07 [0.01]	0.08 [0.01]	0.08 [0.01]			
Downflow Economizer R.A. Damper Open	0.12 [0.03]	0.13 [0.03]	0.13 [0.03]	0.14 [0.03]	0.14 [0.04]	0.15 [0.04]	0.16 [0.04]	0.17 [0.04]	0.18 [0.05]	0.19 [0.05]	0.20 [0.05]	0.21 [0.06]	0.22 [0.06]	0.23 [0.06]	0.24 [0.06]			
Horizontal Economizer R.A. Damper Open	0.02 [0.00]	0.03 [0.01]	0.03 [0.01]	0.04 [0.01]	0.04 [0.01]	0.05 [0.01]	0.05 [0.01]	0.06 [0.01]	0.06 [0.01]	0.07 [0.02]	0.07 [0.02]	0.08 [0.02]	0.08 [0.02]	0.09 [0.02]	0.10 [0.02]			
Concentric Grill RXRN-AD80 or RXRN-AD81 & Transition RXMC-CJ07	0.35 [0.09]	0.39 [0.10]	0.43 [0.11]	0.46 [0.11]	0.50 [0.11]	0.54 [0.13]	0.57 [0.14]	0.61 [0.15]	0.64 [0.16]	0.68 [0.17]	0.72 [0.18]	0.75 [0.19]	0.79 [0.20]	0.83 [0.21]	0.86 [0.21]			
Concentric Grill RXRN-AD86 & Transition RXMC-CK08	0.14 [0.03]	0.17 [0.04]	0.20 [0.05]	0.23 [0.06]	0.26 [0.06]	0.29 [0.07]	0.32 [0.08]	0.35 [0.09]	0.38 [0.09]	0.41 [0.10]	0.44 [0.11]	0.47 [0.12]	0.50 [0.12]	0.53 [0.13]	0.56 [0.14]			

AIRFLOW CORRECTION FACTORS — 17.5 TON [61.5 kW]

ACTUAL—CFM [L/s]	5600 [2643]	5800 [2737]	6000 [2831]	6200 [2926]	6400 [3020]	6600 [3114]	6800 [3209]	7000 [3303]	7200 [3398]	7400 [3492]	7600 [3586]	7800 [3681]	8000 [3775]	8200 [3869]	8400 [3964]
TOTAL MBUH	0.96	0.97	0.97	0.98	0.98	0.99	0.99	1.00	1.00	1.01	1.01	1.02	1.03	1.03	1.04
SENSIBLE MBUH	0.86	0.88	0.90	0.92	0.94	0.96	0.98	1.00	1.02	1.04	1.06	1.08	1.10	1.12	1.14
POWER kW	0.99	0.99	0.99	0.99	1.00	1.00	1.00	1.01	1.01	1.01	1.01	1.01	1.02	1.02	1.02

NOTES: Multiply correction factor times gross performance data—resulting sensible capacity cannot exceed total capacity.

[] Designates Metric Conversions



Air

Indoor Airflow Performance
RLNL-C/H Series

AIRFLOW PERFORMANCE — 20 TON [70.3 kW]—SIDEFLOW (C/H 240)

Capacity		Voltage 208/230, 460, 575 — 3 Phase																			
Air Flow CFM [L/s]		External Static Pressure—Inches of Water [kPa]																			
		0.1 [0.02]	0.2 [0.05]	0.3 [0.07]	0.4 [0.10]	0.5 [0.12]	0.6 [0.15]	0.7 [0.17]	0.8 [0.20]	0.9 [0.22]	1.0 [0.25]	1.1 [0.27]	1.2 [0.30]	1.3 [0.32]	1.4 [0.35]	1.5 [0.37]	1.6 [0.40]	1.7 [0.42]	1.8 [0.45]	1.9 [0.47]	2.0 [0.50]
		RPM	W	RPM	W	RPM	W	RPM	W	RPM	W	RPM	W	RPM	W	RPM	W	RPM	W	RPM	W
6400 [3020]	—	—	—	—	—	—	—	—	—	—	—	—	—	—	—	—	—	—	—	—	—
6600 [3115]	—	—	—	—	—	—	—	—	—	—	—	—	—	—	—	—	—	—	—	—	—
6800 [3209]	—	—	—	—	—	—	—	—	—	—	—	—	—	—	—	—	—	—	—	—	—
7000 [3304]	—	—	—	—	—	—	—	—	—	—	—	—	—	—	—	—	—	—	—	—	—
7200 [3398]	—	—	—	—	—	—	—	—	—	—	—	—	—	—	—	—	—	—	—	—	—
7400 [3492]	—	—	—	—	—	—	—	—	—	—	—	—	—	—	—	—	—	—	—	—	—
7600 [3587]	—	—	—	—	—	—	—	—	—	—	—	—	—	—	—	—	—	—	—	—	—
7800 [3681]	—	—	—	—	—	—	—	—	—	—	—	—	—	—	—	—	—	—	—	—	—
8000 [3776]	632	2485	654	2631	676	2780	698	2931	719	3085	741	3241	763	3399	785	3559	807	3719	829	3880	911
8200 [3870]	644	2640	666	2793	688	2948	710	3105	732	3265	754	3427	776	3582	797	3740	819	3900	841	4060	923
8400 [3964]	657	2805	679	2964	701	3126	723	3290	745	3456	767	3625	789	3796	808	3978	827	4141	849	4300	935
8600 [4059]	670	2980	692	3146	714	3314	736	3484	758	3657	780	3832	800	4017	819	4184	838	4352	856	4521	947
8800 [4153]	683	3166	705	3338	727	3512	749	3689	771	3868	793	4059	812	4229	831	4399	849	4570	867	4742	959
9000 [4248]	697	3361	719	3540	741	3731	763	3904	785	4089	805	4276	824	4449	842	4622	860	4796	877	4971	971
9200 [4342]	711	3567	733	3752	755	3939	777	4129	798	4327	817	4502	835	4678	853	4854	871	5031	888	5209	983
9400 [4436]	725	3783	747	3975	769	4168	792	4381	811	4558	829	4736	847	4915	865	5094	882	5274	899	5455	995
9600 [4531]	739	4010	762	4207	784	4407	805	4617	823	4798	842	4979	859	5161	877	5343	894	5526	910	5709	1007

NOTE: L—Drive left of bold line, M—Drive right of bold line.

Drive Package	L, R	M, S	N (field installed only), T													
Motor H.P. [W]	5.0 [3728.5]	7.5 [5592.7]	7.5 [5592.7]													
Blower Sheave	CK130H	CK130H	CK120H													
Motor Sheave	1VP-56	1VP-71	1VP-71													
Turns Open	1	2	3	4	5	6	1	2	3	4	5	6				
RPM	756	734	709	683	658	631	928	902	874	847	820	793	955	928	899	870

NOTES: 1. Factory sheave settings are shown in bold type.

2. Do not set motor sheave below minimum turns open shown.

3. Re-adjustment of sheave required to achieve rated airflow at AHR1 minimum External Static Pressure.

4. Drive data shown is for horizontal airflow with dry coil. Add component resistance (below) to duct resistance to determine total External Static Pressure.

COMPONENT AIRFLOW RESISTANCE — 20 TON [70.3 kW] (C/H 240)

CFM [L/s]	Resistance — Inches of Water [kPa]																	
	6400 [3020]	6600 [3114]	6800 [3209]	7000 [3303]	7200 [3398]	7400 [3492]	7600 [3586]	7800 [3681]	8000 [3775]	8200 [3869]	8400 [3964]	8600 [4058]	8800 [4153]	9000 [4247]	9200 [4341]	9400 [4436]	9600 [4530]	
Wet Coil	0.00 [0.00]	0.00 [0.00]	0.01 [0.01]	0.01 [0.01]	0.01 [0.01]	0.02 [0.02]	0.02 [0.02]	0.03 [0.03]	0.03 [0.03]	0.04 [0.04]	0.04 [0.04]	0.05 [0.05]	0.05 [0.05]	0.06 [0.06]	0.06 [0.06]	0.07 [0.07]	0.07 [0.07]	
Downflow	0.06 [0.01]	0.06 [0.01]	0.07 [0.02]	0.08 [0.02]	0.08 [0.02]	0.09 [0.02]	0.10 [0.03]	0.11 [0.03]	0.12 [0.03]	0.13 [0.03]	0.14 [0.04]	0.15 [0.04]	0.16 [0.04]	0.17 [0.04]	0.18 [0.05]	0.19 [0.05]	0.20 [0.05]	
Downflow Economizer	0.15 [0.04]	0.16 [0.04]	0.17 [0.04]	0.18 [0.04]	0.19 [0.05]	0.20 [0.05]	0.21 [0.05]	0.22 [0.05]	0.23 [0.06]	0.24 [0.06]	0.25 [0.06]	0.26 [0.06]	0.27 [0.06]	0.28 [0.07]	0.29 [0.07]	0.30 [0.07]	0.30 [0.07]	
Horizontal Economizer	0.04 [0.01]	0.05 [0.01]	0.05 [0.01]	0.06 [0.01]	0.06 [0.01]	0.07 [0.02]	0.07 [0.02]	0.08 [0.02]	0.08 [0.02]	0.09 [0.02]	0.09 [0.02]	0.10 [0.02]	0.10 [0.02]	0.11 [0.03]	0.11 [0.03]	0.12 [0.03]	0.13 [0.03]	
Concentric Grill RXRN-AD86 & Transition RXMC-CX08	0.26 [0.06]	0.29 [0.07]	0.32 [0.08]	0.35 [0.09]	0.38 [0.09]	0.41 [0.10]	0.44 [0.11]	0.47 [0.12]	0.50 [0.12]	0.53 [0.13]	0.56 [0.14]	0.59 [0.15]	0.62 [0.15]	0.65 [0.16]	0.69 [0.17]	0.72 [0.18]	0.75 [0.19]	

AIRFLOW CORRECTION FACTORS — 20 TON [70.3 kW] (C/H 240)

ACTUAL—CFM [L/s]	6400 [3020]	6600 [3114]	6800 [3209]	7000 [3303]	7200 [3398]	7400 [3492]	7600 [3586]	7800 [3681]	8000 [3775]	8200 [3869]	8400 [3964]	8600 [4058]	8800 [4153]	9000 [4247]	9200 [4341]	9400 [4436]	9600 [4530]
TOTAL MBH	0.97	0.97	0.98	0.98	0.99	0.99	1.00	1.00	1.01	1.01	1.01	1.02	1.02	1.03	1.03	1.04	1.04
SENSIBLE MBH	0.88	0.90	0.92	0.94	0.96	0.97	0.99	1.01	1.03	1.05	1.07	1.09	1.10	1.12	1.14	1.16	1.18
POWER kW	0.98	0.99	0.99	0.99	1.00	1.00	1.00	1.00	1.01	1.01	1.01	1.01	1.01	1.02	1.02	1.02	1.02

NOTES: Multiply correction factor times gross performance data—resulting sensible capacity cannot exceed total capacity.

[] Designates Metric Conversions



INTEGRATED AIR & WATER

AIRFLOW PERFORMANCE — 20 TON [70.3 kW] — 60 Hz — SIDEFLOW (C241)

Air Flow CFM [L/s]	Model RLNL-C240 Voltage 208/230, 460, 575 — 3 Phase 60 Hz																																															
	External Static Pressure—Inches of Water [kPa]																																															
	0.1 [0.02]	0.2 [0.05]	0.3 [0.07]	0.4 [0.10]	0.5 [0.12]	0.6 [0.15]	0.7 [0.17]	0.8 [0.20]	0.9 [0.22]	1.0 [0.25]	1.1 [0.27]	1.2 [0.30]	1.3 [0.32]	1.4 [0.35]	1.5 [0.37]	1.6 [0.40]	1.7 [0.42]	1.8 [0.45]	1.9 [0.47]	2.0 [0.50]																												
	RPM	W	RPM	W	RPM	W	RPM	W	RPM	W	RPM	W	RPM	W	RPM	W	RPM	W	RPM	W	RPM	W	RPM	W																								
6400 [3020]	—	—	—	—	685	2151	707	2306	729	2461	750	2617	771	2774	792	2932	813	3090	833	3250	853	3409	872	3570	892	3731	911	3894	929	4056	948	4220	966	4384	984	4549												
6600 [3114]	—	—	—	—	698	2306	720	2462	741	2619	762	2777	783	2936	804	3095	824	3255	844	3415	863	3571	882	3739	901	3902	920	4065	938	4230	956	4396	974	4561	992	4727												
6800 [3209]	—	—	—	—	690	2313	712	2470	733	2628	754	2786	775	2946	795	3106	815	3266	835	3428	854	3590	874	3753	892	3917	911	4081	929	4246	947	4412	965	4579	983	4746	1000	4914										
7000 [3303]	—	—	—	—	682	2327	704	2484	725	2643	746	2802	766	2962	787	3123	807	3285	827	3447	846	3610	865	3774	884	3938	903	4103	921	4269	939	4436	957	4603	974	4771	991	4940	1008	5110								
7200 [3398]	—	—	—	—	696	2505	717	2665	738	2825	759	2985	779	3147	799	3309	819	3472	838	3636	857	3801	876	3966	895	4132	913	4299	931	4466	949	4634	966	4803	983	4973	1000	5143	—	—								
7400 [3492]	—	—	—	—	689	2533	710	2693	731	2854	752	3015	772	3177	792	3341	812	3504	831	3669	850	3834	869	4000	887	4167	906	4334	924	4503	941	4672	959	4841	976	5012	992	5183	1009	5355	—	—						
7600 [3586]	682	2566	704	2727	724	2889	745	3051	765	3214	785	3378	805	3543	824	3708	843	3874	862	4041	880	4209	899	4377	917	4546	934	4716	951	4886	968	5057	985	5229	1002	5402	—	—	—	—	—							
7800 [3681]	697	2768	718	2931	739	3094	759	3258	779	3423	798	3588	818	3754	837	3921	856	4089	874	4257	892	4426	910	4596	928	4766	945	4937	962	5109	979	5282	995	5456	—	—	—	—	—	—	—							
8000 [3775]	712	2979	733	3143	753	3308	773	3473	793	3640	812	3806	831	3974	850	4142	868	4312	886	4481	904	4652	921	4823	939	4995	956	5168	972	5342	989	5516	1009	5691	—	—	—	—	—	—	—							
8200 [3869]	728	3199	748	3365	768	3531	787	3698	806	3865	825	4034	844	4203	862	4373	881	4543	898	4715	916	4887	933	5060	950	5233	967	5407	983	5583	999	5758	—	—	—	—	—	—	—	—	—							
8400 [3964]	743	3428	763	3595	782	3762	802	3931	820	4100	839	4270	857	4441	875	4612	893	4784	911	4957	928	5131	945	5305	961	5480	978	5656	994	5832	1009	6010	—	—	—	—	—	—	—	—	—							
8600 [4058]	758	3665	778	3834	797	4003	816	4173	835	4343	853	4515	871	4687	889	4860	906	5034	923	5208	940	5383	956	5559	973	5735	989	5913	1004	6091	—	—	—	—	—	—	—	—	—	—	—							
9000 [4247]	790	4166	808	4338	827	4510	845	4683	863	4857	881	5031	898	5206	915	5382	932	5559	948	5736	964	5915	980	6093	996	6273	—	—	—	—	—	—	—	—	—	—	—	—	—	—	—	—	—	—				
9200 [4341]	805	4430	824	4603	842	4771	860	4951	877	5127	895	5303	912	5479	929	5657	945	5835	961	6014	977	6194	992	6374	1008	6555	—	—	—	—	—	—	—	—	—	—	—	—	—	—	—	—	—	—				
9400 [4436]	821	4703	839	4877	857	5052	875	5229	892	5405	909	5583	926	5767	942	5940	958	6120	974	6300	989	6481	1005	6663	—	—	—	—	—	—	—	—	—	—	—	—	—	—	—	—	—	—	—	—	—			
9600 [4530]	837	4984	855	5160	872	5337	890	5514	907	5693	923	5872	940	6052	956	6232	971	6413	987	6595	1002	6778	—	—	—	—	—	—	—	—	—	—	—	—	—	—	—	—	—	—	—	—	—	—	—	—	—	—

NOTE: L-Drive left of bold line, M-Drive right of bold line, N-Drive right of double line.

Drive Package	L	M	N (field installed only)
Motor H.P. [W]	5.0 [3728.5]	7.5 [5592.7]	7.5 [5592.7]
Blower Sheave	BK120H	BK130H	BK120H
Motor Sheave	1VP-56	1VP-71	1VP-71
Turns Open	1 2 3 4 5 6	1 2 3 4 5 6	1 2 3 4 5 6
RPM	822 798 771 742 712 684	932 905 878 851 824 797	1007 978 949 921 892 863

NOTES: 1. Factory sheave settings are shown in bold type.

2. Do not set motor sheave below minimum turns open shown.

3. Re-adjustment of sheave required to achieve rated airflow at AHRI minimum External Static Pressure.

4. Drive data shown is for horizontal airflow with dry coil. Add component resistance (below) to duct resistance to determine total External Static Pressure.

[] Designates Metric Conversions

COMPONENT AIRFLOW RESISTANCE—20 TON [70.3 kW] (C241)

Airflow CFM [L/s]	Airflow Correction Factors*				Component Airflow Resistance						
	Sensible MBH		Power kW		Wet Coil	Downflow	Downflow Economizer RA Damper Open	Horizontal Economizer RA Damper Open	Concentric Grill RXRN-AD80 or RXRN-AD81 & Transition RXMC-CJ07	Concentric Grill RXRN-AD86 & Transition RXMC-CK08	Concentric Grill RXRN-AD88 & Transition RXMC-CL09
	Total MBH										
6400 [3020]	0.97	0.88	0.98	0.01 [.00]	0.06 [.01]	0.15 [.04]	0.04 [.01]	0.50 [.12]	—	—	—
6600 [3114]	0.97	0.90	0.99	0.02 [.00]	0.06 [.01]	0.16 [.04]	0.05 [.01]	0.54 [.13]	—	—	—
6800 [3209]	0.98	0.92	0.99	0.03 [.01]	0.07 [.02]	0.16 [.04]	0.05 [.01]	—	—	—	—
7000 [3303]	0.98	0.94	0.99	0.03 [.01]	0.08 [.02]	0.17 [.04]	0.06 [.01]	—	—	—	—
7200 [3398]	0.99	0.96	0.99	0.04 [.01]	0.08 [.02]	0.18 [.04]	0.06 [.01]	—	0.38 [.09]	—	—
7400 [3492]	0.99	0.97	1.00	0.05 [.01]	0.09 [.02]	0.19 [.05]	0.07 [.02]	—	0.41 [.10]	—	—
7600 [3586]	1.00	0.99	1.00	0.06 [.01]	0.10 [.02]	0.20 [.05]	0.07 [.02]	—	0.44 [.11]	—	—
7800 [3681]	1.00	1.01	1.00	0.06 [.01]	0.11 [.03]	0.21 [.05]	0.08 [.02]	—	0.47 [.12]	—	—
8000 [3775]	1.01	1.03	1.00	0.07 [.02]	0.12 [.03]	0.22 [.05]	0.09 [.02]	—	0.50 [.12]	—	—
8200 [3869]	1.01	1.05	1.01	0.08 [.02]	0.13 [.03]	0.23 [.06]	0.09 [.02]	—	0.53 [.13]	—	—
8400 [3964]	1.02	1.07	1.01	0.09 [.02]	0.14 [.03]	0.24 [.06]	0.10 [.02]	—	0.56 [.14]	—	—
8600 [4058]	1.02	1.09	1.01	0.09 [.02]	0.15 [.04]	0.25 [.06]	0.10 [.02]	—	0.59 [.15]	—	—
8800 [4153]	1.03	1.10	1.01	0.10 [.02]	0.16 [.04]	0.26 [.06]	0.11 [.03]	—	0.62 [.15]	—	—
9000 [4247]	1.03	1.12	1.01	0.11 [.03]	0.18 [.04]	0.27 [.07]	0.11 [.03]	—	—	—	—
9200 [4341]	1.03	1.14	1.02	0.12 [.03]	0.19 [.05]	0.28 [.07]	0.12 [.03]	—	—	—	—
9400 [4436]	1.04	1.16	1.02	0.12 [.03]	0.20 [.05]	0.29 [.07]	0.12 [.03]	—	—	—	—
9600 [4530]	1.04	1.18	1.02	0.13 [.03]	0.22 [.05]	0.30 [.07]	0.13 [.03]	—	—	—	—

* Multiply correction factor times gross performance data—resulting sensible capacity cannot exceed total capacity.

[] Designates Metric Conversions

AIRFLOW PERFORMANCE — 25 TON [87.9 kW]—SIDEFLOW

Air Flow CFM [L/s]	Capacity 25 Ton [87.9 kW] Voltage 208/230, 460, 575 — 3 Phase																			
	External Static Pressure—Inches of Water [kPa]																			
	0.1 [0.2]	0.2 [1.05]	0.3 [0.7]	0.4 [1.10]	0.5 [1.12]	0.6 [1.15]	0.7 [1.17]	0.8 [1.20]	0.9 [1.22]	1.0 [1.25]	1.1 [1.27]	1.2 [1.30]	1.3 [1.32]	1.4 [1.35]	1.5 [1.37]	1.6 [1.40]	1.7 [1.42]	1.8 [1.45]	1.9 [1.47]	2.0 [1.50]
8000 [3775]	—	—	—	—	—	—	794 [3720]	814 [3870]	833 [4024]	851 [4182]	869 [4344]	886 [4510]	903 [4680]	920 [4854]	948 [5256]	963 [5410]	979 [5566]	994 [5720]	1009 [5877]	—
8200 [3869]	—	—	—	—	—	—	807 [3908]	826 [4065]	845 [4226]	863 [4392]	880 [4561]	897 [4735]	914 [4912]	943 [5296]	958 [5465]	973 [5614]	988 [5774]	1003 [5935]	1018 [6097]	—
8400 [3964]	—	—	—	—	—	—	801 [3947]	820 [4108]	838 [4273]	856 [4442]	874 [4614]	891 [4791]	908 [4972]	924 [5157]	952 [5503]	967 [5667]	982 [5832]	997 [5997]	1012 [6164]	1028 [6331]
8600 [4058]	—	—	—	—	—	—	794 [3989]	813 [4153]	832 [4321]	850 [4493]	868 [4670]	886 [4850]	902 [5034]	919 [5223]	947 [5557]	962 [5725]	977 [5894]	1007 [6235]	1022 [6407]	1037 [6579]
8800 [4153]	—	—	—	—	—	—	807 [4026]	826 [4191]	845 [4367]	862 [4547]	879 [4731]	897 [4919]	913 [5112]	929 [5310]	957 [5787]	972 [5960]	987 [6134]	1002 [6310]	1017 [6486]	1032 [6663]
9000 [4247]	—	—	—	—	—	—	801 [4249]	820 [4424]	839 [4603]	857 [4786]	874 [4973]	892 [5164]	908 [5359]	924 [5558]	952 [5853]	967 [6031]	982 [6209]	997 [6389]	1012 [6570]	1027 [6752]
9200 [4341]	—	—	—	—	—	—	815 [4478]	833 [4660]	851 [4847]	869 [5037]	886 [5232]	903 [5430]	919 [5633]	947 [5923]	962 [6105]	977 [6289]	992 [6473]	1007 [6658]	1022 [6844]	1037 [7031]
9400 [4436]	—	—	—	—	—	—	790 [4352]	809 [4534]	828 [4720]	846 [4910]	864 [5104]	881 [5302]	898 [5504]	915 [5710]	943 [5997]	958 [6184]	972 [6372]	987 [6561]	1002 [6750]	1017 [6941]
9600 [4530]	—	—	—	—	—	—	804 [4592]	823 [4781]	841 [4975]	859 [5172]	876 [5373]	893 [5579]	910 [5788]	926 [6002]	953 [6267]	968 [6460]	983 [6653]	998 [6847]	1013 [7042]	1028 [7238]
9800 [4624]	—	—	—	—	—	—	798 [4652]	817 [4845]	836 [5042]	854 [5242]	872 [5447]	889 [5656]	905 [5869]	922 [6085]	949 [6355]	964 [6551]	979 [6749]	1009 [7147]	1024 [7347]	1039 [7548]
10000 [4719]	793 [4714]	813 [4910]	831 [5110]	849 [5315]	867 [5523]	884 [5735]	901 [5951]	917 [6171]	945 [6446]	960 [6647]	975 [6849]	990 [7052]	1005 [7256]	1019 [7461]	1034 [7667]	1050 [7873]	1065 [8081]	—	—	—
10200 [4813]	808 [4978]	827 [5181]	845 [5389]	863 [5600]	880 [5816]	897 [6035]	913 [6259]	941 [6542]	956 [6748]	971 [6954]	986 [7162]	1001 [7370]	1016 [7579]	1031 [7789]	1046 [8000]	1061 [8212]	—	—	—	—
10400 [4908]	822 [5254]	840 [5465]	858 [5680]	876 [5899]	893 [6122]	909 [6349]	926 [6580]	953 [6852]	967 [7063]	982 [7275]	997 [7488]	1012 [7701]	1027 [7916]	1042 [8131]	1057 [8348]	1072 [8565]	—	—	—	—
10600 [5002]	836 [5543]	854 [5761]	872 [5984]	889 [6210]	906 [6441]	922 [6675]	949 [6961]	964 [7176]	979 [7393]	993 [7610]	1008 [7828]	1023 [8047]	1038 [8267]	1053 [8488]	1068 [8710]	—	—	—	—	—
10800 [5096]	850 [5845]	868 [6071]	885 [6301]	902 [6534]	918 [6772]	946 [7074]	961 [7294]	975 [7514]	990 [7736]	1005 [7959]	1020 [8182]	1035 [8407]	1050 [8632]	1065 [8858]	—	—	—	—	—	—
11000 [5191]	864 [6160]	882 [6393]	899 [6630]	915 [6871]	943 [7191]	958 [7415]	972 [7640]	987 [7867]	1002 [8094]	1017 [8321]	1032 [8550]	1046 [8780]	1061 [9011]	—	—	—	—	—	—	—
11200 [5285]	878 [6487]	895 [6728]	912 [6972]	940 [7313]	955 [7541]	969 [7771]	984 [8001]	999 [8233]	1014 [8465]	1029 [8698]	1043 [8933]	1058 [9168]	—	—	—	—	—	—	—	—
11400 [5379]	892 [6827]	909 [7075]	925 [7328]	952 [7671]	967 [7905]	981 [8140]	996 [8376]	1011 [8613]	1026 [8851]	1041 [9089]	1055 [9329]	1070 [9570]	—	—	—	—	—	—	—	—
11600 [5474]	906 [7180]	922 [7436]	950 [7806]	964 [8044]	979 [8283]	994 [8524]	1008 [8765]	1023 [9007]	1038 [9250]	1053 [9494]	1068 [9739]	—	—	—	—	—	—	—	—	—
11800 [5568]	920 [7546]	948 [7944]	962 [8187]	977 [8431]	991 [8676]	1006 [8921]	1021 [9168]	1035 [9416]	1050 [9664]	1065 [9913]	—	—	—	—	—	—	—	—	—	—
12000 [5663]	946 [8087]	960 [8334]	975 [8583]	989 [8832]	1004 [9082]	1019 [9333]	1033 [9585]	1048 [9838]	1063 [10092]	—	—	—	—	—	—	—	—	—	—	—

NOTE: L-Drive left of bold line, M-Drive right of bold line.

Drive Package	L, R	M, S
Motor H.P. [W]	7.5 [5592.7]	10 [7457.0]
Blower Sheave	CK130H	CK120H
Motor Sheave	1VP-71	1VP-75
Turns Open	1 2 3 4 5 6	1 2 3 4 5 6
RPM	919 894 869 844 817 790 1067 1039 1012 982 953 925	

- NOTES: 1. Factory sheave settings are shown in bold type.
 2. Do not set motor sheave below minimum turns open shown.
 3. Re-adjustment of sheave required to achieve rated airflow at AHRI minimum External Static Pressure.
 4. Drive data shown is for horizontal airflow with dry coil. Add component resistance (below) to duct resistance to determine total External Static Pressure.

COMPONENT AIR RESISTANCE — 25 TON [87.9 kW]

CFM [L/s]	Resistance — Inches of Water [kPa]										
	8000 [3775]	8400 [3964]	8800 [4153]	9200 [4341]	9600 [4530]	10000 [4719]	10400 [4908]	10800 [5096]	11200 [5285]	11600 [5474]	12000 [5663]
Wet Coil	0.07 [0.2]	0.09 [0.2]	0.10 [0.2]	0.12 [0.3]	0.13 [0.3]	0.15 [0.4]	0.16 [0.4]	0.18 [0.4]	0.19 [0.5]	0.21 [0.5]	0.22 [0.6]
Downflow	0.12 [0.3]	0.14 [0.3]	0.16 [0.4]	0.19 [0.4]	0.22 [0.5]	0.25 [0.6]	0.29 [0.7]	0.33 [0.8]	0.37 [0.9]	0.42 [1.0]	0.46 [1.1]
Downflow Economizer R.A. Damper Open	0.22 [0.5]	0.24 [0.6]	0.26 [0.6]	0.28 [0.7]	0.30 [0.7]	0.32 [0.8]	0.34 [0.8]	0.37 [0.9]	0.39 [1.0]	0.41 [1.1]	0.44 [1.2]
Horizontal Economizer R.A. Damper Open	0.09 [0.2]	0.10 [0.2]	0.11 [0.3]	0.12 [0.3]	0.13 [0.3]	0.14 [0.4]	0.15 [0.4]	0.16 [0.4]	0.17 [0.4]	0.18 [0.5]	0.19 [0.5]
Concentric Grill RXRN-AD88 & Transition RXMC-CL09	0.17 [0.4]	0.23 [0.6]	0.30 [0.7]	0.36 [0.8]	0.43 [0.9]	0.50 [0.6]	0.56 [0.6]	0.63 [0.6]	0.69 [0.7]	0.76 [0.8]	0.82 [1.0]

AIRFLOW CORRECTION FACTORS — 25 TON [87.9 kW]

ACTUAL—CFM [L/s]	8000 [3775]	8400 [3964]	8800 [4153]	9200 [4341]	9600 [4530]	10000 [4719]	10400 [4908]	10800 [5096]	11200 [5285]	11600 [5474]	12000 [5663]
TOTAL MBTUH	0.97	0.98	0.99	0.99	1.00	1.01	1.02	1.03	1.03	1.04	1.05
SENSIBLE MBTUH	0.89	0.92	0.95	0.98	1.01	1.04	1.08	1.11	1.14	1.17	1.20
POWER kW	0.99	0.99	1.00	1.00	1.00	1.01	1.01	1.01	1.02	1.02	1.02

NOTES: Multiply correction factor times gross performance data—resulting sensible capacity cannot exceed total capacity.

[] Designates Metric Conversions

ELECTRICAL DATA – RLNL- SERIES										
		C180CL H180CR	C180CM H180CS	C180DL H180DR	C180DM H180DS	C180YL	C180YM	C210CL H210CR	C210CM H210CS	C210DL H210DR
Unit Information	Unit Operating Voltage Range	187-253	187-253	414-506	414-506	518-632	518-632	187-253	187-253	414-506
	Volts	208/230	208/230	460	460	575	575	208/230	208/230	460
	Minimum Circuit Ampacity	78/78	81/81	38	40	28	30	88/88	91/91	44
	Minimum Overcurrent Protection Device Size	90/90	90/90	45	45	30	35	100/100	100/100	50
	Maximum Overcurrent Protection Device Size	100/100	100/100	45	50	35	35	110/110	110/110	50
Compressor Motor	No.	2	2	2	2	2	2	2	2	2
	Volts	200/230	200/230	460	460	575	575	200/230	200/230	460
	Phase	3	3	3	3	3	3	3	3	3
	RPM	3450	3450	3450	3450	3450	3450	3450	3450	3450
	HP, Compressor 1	7	7	7	7	7	7	7 1/2	7 1/2	7 1/2
	Amps (RLA), Comp. 1	25/25	25/25	12.2	12.2	9	9	29.5/29.5	29.5/29.5	14.7
	Amps (LRA), Comp. 1	164/164	164/164	100	100	78	78	195/195	195/195	95
	HP, Compressor 2	7	7	7	7	7	7	7 1/2	7 1/2	7 1/2
	Amps (RLA), Comp. 2	25/25	25/25	12.2	12.2	9	9	29.5/29.5	29.5/29.5	14.7
Amps (LRA), Comp. 2	164/164	164/164	100	100	78	78	195/195	195/195	95	
Condenser Motor	No.	4	4	4	4	4	4	4	4	4
	Volts	208/230	208/230	460	460	575	575	208/230	208/230	460
	Phase	1	1	1	1	1	1	1	1	1
	HP	1/3	1/3	1/3	1/3	1/3	1/3	1/3	1/3	1/3
	Amps (FLA, each)	2.4/2.4	2.4/2.4	1.4	1.4	1	1	2.4/2.4	2.4/2.4	1.4
	Amps (LRA, each)	4.7/4.7	4.7/4.7	2.4	2.4	1.8	1.8	4.7/4.7	4.7/4.7	2.4
Evaporator Fan	No.	1	1	1	1	1	1	1	1	1
	Volts	208/230	208/230	460	460	575	575	208/230	208/230	460
	Phase	3	3	3	3	3	3	3	3	3
	HP	3	5	3	5	3	5	3	5	3
	Amps (FLA, each)	11.5/11.5	14.9/14.9	4.6	6.6	3.5	5.3	11.5/11.5	14.9/14.9	4.6
	Amps (LRA, each)	74.5/74.5	82.6/82.6	38.1	46.3	20	39.4	74.5/74.5	82.6/82.6	38.1



Air

Electrical Data
RLNL-C/H Series**ELECTRICAL DATA – RLNL- SERIES**

		C210DM H210DS	C210YL	C210YM	C240CL H240CR	C240CM H240CS	C240CN H240CT	C240DL H240DR	C240DM H240DS	C240DN H240DT
Unit Information	Unit Operating Voltage Range	414-506	518-632	518-632	187-253	187-253	187-253	414-506	414-506	414-506
	Volts	460	575	575	208/230	208/230	208/230	460	460	460
	Minimum Circuit Ampacity	46	35	37	101/101	109/109	109/109	52	56	56
	Minimum Overcurrent Protection Device Size	50	40	40	110/110	125/125	125/125	60	60	60
	Maximum Overcurrent Protection Device Size	50	45	45	125/125	125/125	125/125	60	70	70
Compressor Motor	No.	2	2	2	2	2	2	2	2	2
	Volts	460	575	575	200/230	200/230	200/230	460	460	460
	Phase	3	3	3	3	3	3	3	3	3
	RPM	3450	3450	3450	3450	3450	3450	3450	3450	3450
	HP, Compressor 1	7 1/2	7 1/2	7 1/2	10	10	10	10	10	10
	Amps (RLA), Comp. 1	14.7	12.2	12.2	33.3/33.3	33.3/33.3	33.3/33.3	17.9	17.9	17.9
	Amps (LRA), Comp. 1	95	80	80	239/239	239/239	239/239	125	125	125
	HP, Compressor 2	7 1/2	7 1/2	7 1/2	7 1/2	7 1/2	7 1/2	7 1/2	7 1/2	7 1/2
	Amps (RLA), Comp. 2	14.7	12.2	12.2	29.5/29.5	29.5/29.5	29.5/29.5	14.7	14.7	14.7
Amps (LRA), Comp. 2	95	80	80	195/195	195/195	195/195	95	95	95	
Condenser Motor	No.	4	4	4	6	6	6	6	6	6
	Volts	460	575	575	208/230	208/230	208/230	460	460	460
	Phase	1	1	1	1	1	1	1	1	1
	HP	1/3	1/3	1/3	1/3	1/3	1/3	1/3	1/3	1/3
	Amps (FLA, each)	1.4	1	1	2.4/2.4	2.4/2.4	2.4/2.4	1.4	1.4	1.4
	Amps (LRA, each)	2.4	1.8	1.8	4.7/4.7	4.7/4.7	4.7/4.7	2.4	2.4	2.4
Evaporator Fan	No.	1	1	1	1	1	1	1	1	1
	Volts	460	575	575	208/230	208/230	208/230	460	460	460
	Phase	3	3	3	3	3	3	3	3	3
	HP	5	3	5	5	7 1/2	7 1/2	5	7 1/2	7 1/2
	Amps (FLA, each)	6.6	3.5	5.3	14.7/14.7	23.1/23.1	23.1/23.1	6.6	9.6	9.6
	Amps (LRA, each)	46.3	20	39.4	82.6/82.6	136/136	136/136	46.3	67	67



ELECTRICAL DATA – RLNL- SERIES										
		C240YL	C240YM	C240YN	C241CL	C241CM	C241DL	C241DM	C241YL	C241YM
Unit Information	Unit Operating Voltage Range	518-632	518-632	518-632	187-253	187-253	414-506	414-506	518-632	518-632
	Volts	575	575	575	208/230	208/230	460	460	575	575
	Minimum Circuit Ampacity	40	42	42	95/95	103/103	49	52	37	39
	Minimum Overcurrent Protection Device Size	45	50	50	110/110	125/125	60	60	40	45
	Maximum Overcurrent Protection Device Size	50	50	50	110/110	125/125	60	60	45	50
Compressor Motor	No.	2	2	2	2	2	2	2	2	2
	Volts	575	575	575	200/230	200/230	460	460	575	575
	Phase	3	3	3	3	3	3	3	3	3
	RPM	3450	3450	3450	3450	3450	3450	3450	3450	3450
	HP, Compressor 1	10	10	10	10	10	10	10	10	10
	Amps (RLA), Comp. 1	12.8	12.8	12.8	30.1/30.1	30.1/30.1	16.7	16.7	12.2	12.2
	Amps (LRA), Comp. 1	80	80	80	225/225	225/225	114	114	80	80
	HP, Compressor 2	7 1/2	7 1/2	7 1/2	7 1/2	7 1/2	7 1/2	7 1/2	7 1/2	7 1/2
	Amps (RLA), Comp. 2	12.2	12.2	12.2	27.6/27.6	27.6/27.6	12.8	12.8	9.6	9.6
Amps (LRA), Comp. 2	80	80	80	191/191	191/191	100	100	78	78	
Condenser Motor	No.	6	6	6	6	6	6	6	6	6
	Volts	575	575	575	208/230	208/230	460	460	575	575
	Phase	1	1	1	1	1	1	1	1	1
	HP	1/3	1/3	1/3	1/3	1/3	1/3	1/3	1/3	1/3
	Amps (FLA, each)	1	1	1	2.4/2.4	2.4/2.4	1.4	1.4	1	1
	Amps (LRA, each)	1.8	1.8	1.8	4.7/4.7	4.7/4.7	2.4	2.4	1.8	1.8
Evaporator Fan	No.	1	1	1	1	1	1	1	1	1
	Volts	575	575	575	208/230	208/230	460	460	575	575
	Phase	3	3	3	3	3	3	3	3	3
	HP	5	7 1/2	7 1/2	5	7 1/2	5	7 1/2	5	7 1/2
	Amps (FLA, each)	5.3	7.8	7.8	14.7/14.7	23.1/23.1	6.6	9.6	5.3	7.8
	Amps (LRA, each)	39.4	53.8	53.8	82.6/82.6	136/136	46.3	67	39.4	53.8



ELECTRICAL DATA – RLNL- SERIES

		H300CR	H300CS	H300DR	H300DS
Unit Information	Unit Operating Voltage Range	187-253	187-253	414-506	414-506
	Volts	208/230	208/230	460	460
	Minimum Circuit Ampacity	147/147	149/149	60	63
	Minimum Overcurrent Protection Device Size	175/175	175/175	70	70
	Maximum Overcurrent Protection Device Size	175/175	175/175	70	80
Compressor Motor	No.	2	2	2	2
	Volts	200/240	200/240	460	460
	Phase	3	3	3	3
	RPM	3450	3450	3450	3450
	HP, Compressor 1	11 1/2	11 1/2	11 1/2	11 1/2
	Amps (RLA), Comp. 1	48.1/48.1	48.1/48.1	18.6	18.6
	Amps (LRA), Comp. 1	245/245	245/245	125	125
	HP, Compressor 2	11 1/2	11 1/2	11 1/2	11 1/2
	Amps (RLA), Comp. 2	48.1/48.1	48.1/48.1	18.6	18.6
Amps (LRA), Comp. 2	245/245	245/245	125	125	
Condenser Motor	No.	6	6	6	6
	Volts	208/230	208/230	460	460
	Phase	1	1	1	1
	HP	1/3	1/3	1/3	1/3
	Amps (FLA, each)	2.4/2.4	2/2	1.4	1.4
	Amps (LRA, each)	4.7/4.7	3.9/3.9	2.4	2.4
Evaporator Fan	No.	1	1	1	1
	Volts	208/230	208/230	460	460
	Phase	3	3	3	3
	HP	7 1/2	10	7 1/2	10
	Amps (FLA, each)	24.2/24.2	28.5/28.5	9.6	12.5
	Amps (LRA, each)	136/136	178/178	67	74.6



208/240 VOLT, THREE PHASE, 60 HZ, AUXILIARY ELECTRIC HEATER KITS CHARACTERISTICS AND APPLICATION													
Separate Power Supply for Both Unit and Heater Kit													
Model No. RLNL-	Single Power Supply for Both Unit and Heater Kit					Heater Kit				Air Conditioner			
	RXJJ-Heater Kit Nominal KW	No. of Sequence Steps	Rated Heater kW @ 208/240V	Heater kBTU/Hr @ 208/240V	Heater Amps @ 208/240V	Unit Min. Ckt. Ampacity @ 208/240V	Over Current Protective Device Size		Min. Circuit Ampacity 208/240V	Max. Fuse Size 208/240V	Air Conditioner		
							Min./Max. 208V	Min./Max. 240V			Min./Max. 208V	Min./Max. 240V	
C180CL H180CR	No Heat	—	—	—	—	78/78	90/100	90/100	—	—	78/78	90/100	90/100
	CE20C	1	14.4/19.2	49.13/65.5	40/46.2	78/78	90/100	90/100	50/58	50/60	—	—	—
	CE40C	2	28.8/38.3	98.25/130.66	79.9/92.2	115/130	125/125	150/150	100/116	100/125	—	—	—
C210CL H210CR	No Heat	—	—	—	—	165/188	200/200	200/200	—	—	—	—	—
	CE20C	1	14.4/19.2	49.13/65.5	40/46.2	88/88	100/110	100/110	50/58	50/60	—	—	—
	CE40C	2	28.8/38.3	98.25/130.66	79.9/92.2	115/130	125/125	150/150	100/116	100/125	—	—	—
C240CL H240CR	No Heat	—	—	—	—	188/217	250/250	250/250	—	—	—	—	—
	CE20C	1	14.4/19.2	49.13/65.5	40/46.2	101/101	110/125	110/125	50/58	50/60	—	—	—
	CE40C	2	28.8/38.3	98.25/130.66	79.9/92.2	119/134	125/125	150/150	100/116	100/125	—	—	—
H300CR	No Heat	—	—	—	—	147/147	175/175	175/175	—	—	—	—	—
	CE20C	1	14.4/19.2	49.13/65.5	40/46.2	147/147	175/175	175/175	50/58	50/60	—	—	—
	CE40C	2	28.8/38.3	98.25/130.66	79.9/92.2	147/147	175/175	175/175	100/116	100/125	—	—	—
C180CM H180CS	No Heat	—	—	—	—	206/235	250/250	250/250	—	—	—	—	—
	CE20C	1	14.4/19.2	49.13/65.5	40/46.2	81/81	90/100	90/100	50/58	50/60	—	—	—
	CE40C	2	28.8/38.3	98.25/130.66	79.9/92.2	119/134	125/125	150/150	100/116	100/125	—	—	—
C210CM H210CS	No Heat	—	—	—	—	188/217	250/250	250/250	—	—	—	—	—
	CE20C	1	14.4/19.2	49.13/65.5	40/46.2	91/91	100/110	100/110	50/58	50/60	—	—	—
	CE40C	2	28.8/38.3	98.25/130.66	79.9/92.2	119/134	125/125	150/150	100/116	100/125	—	—	—
C240CM H240CS	No Heat	—	—	—	—	109/109	125/125	125/125	—	—	—	—	—
	CE20C	1	14.4/19.2	49.13/65.5	40/46.2	109/109	125/125	125/125	50/58	50/60	—	—	—
	CE40C	2	28.8/38.3	98.25/130.66	79.9/92.2	129/145	150/150	150/150	100/116	100/125	—	—	—
H300CS	No Heat	—	—	—	—	149/149	175/175	175/175	—	—	—	—	—
	CE20C	1	14.4/19.2	49.13/65.5	40/46.2	149/149	175/175	175/175	50/58	50/60	—	—	—
	CE40C	2	28.8/38.3	98.25/130.66	79.9/92.2	149/151	175/175	175/175	100/116	100/125	—	—	—
C240CN H240CT	No Heat	—	—	—	—	109/109	125/125	125/125	—	—	—	—	—
	CE20C	1	14.4/19.2	49.13/65.5	40/46.2	109/109	125/125	125/125	50/58	50/60	—	—	—
	CE40C	2	28.8/38.3	98.25/130.66	79.9/92.2	129/145	150/150	150/150	100/116	100/125	—	—	—

 * = For Canadian use only. Uses "P" fuses for inductive circuit.
 + = Field installed only.

480 VOLT, THREE PHASE, 60 HZ, AUXILIARY ELECTRIC HEATER KITS CHARACTERISTICS AND APPLICATION													
Single Power Supply for Both Unit and Heater Kit										Separate Power Supply for Both Unit and Heater Kit			
Model No. RLNL-	RXJJ-Heater Kit Nominal kW	No. of Sequence Steps	Rated Heater kW @ 480V	Heater kBTU/HR @ 480V	Heater Amps @ 480V	Unit Min. Ckt. Ampacity @ 480V	Air Conditioner		Heater Kit		Air Conditioner		
							Protective Device Size Min./Max. 480V	Over Current Protective Device Size Min./Max. 480V	Min. Ckt. Ampacity 480V	Max. Fuse Size 480V	Min. Ckt. Ampacity 480V	Over Current Protective Device Size Min./Max. 480V	
C180DL H180DR	No Heat	—	—	—	—	38	45/45	—	—	38	—	45/45	
	CE20D	1	19.2	65.5	23.1	38	45/45	—	—	29	30	—	
	CE40D	2	38.4	131	46.2	64	70/70	—	—	58	60	—	
	CE60D	2	57.6	196.5	69.3	93	100/100	—	—	87	90	—	
C210DL H210DR	CE75D	2	72	245.63	86.6	114	125/125	—	—	109	110	—	
	No Heat	—	—	—	—	44	50/50	—	—	44	—	50/50	
	CE20D	1	19.2	65.5	23.1	44	50/50	—	—	29	30	—	
	CE40D	2	38.4	131	46.2	64	70/70	—	—	58	60	—	
C240DL H240DR	CE60D	2	57.6	196.5	69.3	93	100/100	—	—	87	90	—	
	CE75D	2	72	245.63	86.6	114	125/125	—	—	109	110	—	
	No Heat	—	—	—	—	52	60/60	—	—	52	—	60/60	
	CE20D	1	19.2	65.5	23.1	52	60/60	—	—	29	30	—	
H300DR	CE40D	2	38.4	131	46.2	67	70/70	—	—	58	60	—	
	CE60D	2	57.6	196.5	69.3	95	100/100	—	—	87	90	—	
	CE75D	2	72	245.63	86.6	117	125/125	—	—	109	110	—	
	No Heat	—	—	—	—	60	70/70	—	—	60	—	70/70	
C180DM H180DS	CE20D	1	19.2	65.5	23.1	40	45/50	—	—	29	30	—	
	CE40D	2	38.4	131	46.2	67	70/70	—	—	58	60	—	
	CE60D	2	57.6	196.5	69.3	95	100/100	—	—	87	90	—	
	CE75D	2	72	245.63	86.6	117	125/125	—	—	109	110	—	
C210DM H210DS	No Heat	—	—	—	—	46	50/50	—	—	46	—	50/50	
	CE20D	1	19.2	65.5	23.1	46	50/50	—	—	29	30	—	
	CE40D	2	38.4	131	46.2	67	70/70	—	—	58	60	—	
	CE60D	2	57.6	196.5	69.3	95	100/100	—	—	87	90	—	
C240DM H240DS	CE75D	2	72	245.63	86.6	117	125/125	—	—	109	110	—	
	No Heat	—	—	—	—	56	60/70	—	—	56	—	60/70	
	CE20D	1	19.2	65.5	23.1	56	60/70	—	—	29	30	—	
	CE40D	2	38.4	131	46.2	70	70/70	—	—	58	60	—	
H300DS	CE60D	2	57.6	196.5	69.3	99	100/100	—	—	87	90	—	
	CE75D	2	72	245.63	86.6	121	125/125	—	—	109	110	—	
	No Heat	—	—	—	—	63	70/80	—	—	63	—	70/80	
	CE20D	1	19.2	65.5	23.1	63	70/80	—	—	29	30	—	
C240DN H240DT	CE40D	2	38.4	131	46.2	74	80/80	—	—	58	60	—	
	CE60D	2	57.6	196.5	69.3	103	110/110	—	—	87	90	—	
	CE75D	2	72	245.63	86.6	124	125/125	—	—	109	110	—	
	No Heat	—	—	—	—	56	60/70	—	—	56	—	60/70	
C240DN H240DT	CE20D	1	19.2	65.5	23.1	56	60/70	—	—	29	30	—	
	CE40D	2	38.4	131	46.2	70	70/70	—	—	58	60	—	
	CE60D	2	57.6	196.5	69.3	99	100/100	—	—	87	90	—	
	CE75D	2	72	245.63	86.6	121	125/125	—	—	109	110	—	

* = For Canadian use only. Uses "P" fuses for inductive circuit.

+ = Field installed only.

600 VOLT, THREE PHASE, 60 HZ., AUXILIARY ELECTRIC HEATER KITS CHARACTERISTICS AND APPLICATION												
Single Power Supply for Both Unit and Heater Kit				Heater Kit				Air Conditioner				Separate Power Supply for Both Unit and Heater Kit
Model No. RLNL-	RXJJ-Heater Kit Nominal kW	No. of Sequence Steps	Rated Heater kW @ 600V	Heater kBTU/Hr @ 600V	Heater Amps @ 600V	Unit Min. Ckt. Ampacity @ 600V	Over Current Protective Device Size		Min. Ckt. Ampacity 600V	Max. Fuse Size 600V	Min. Circuit Ampacity 600V	Over Current Protective Device Size Min./Max. 600V
							Min./Max. 600V	Min./Max. 600V				
C180YL	No Heat	—	—	—	—	28	30/35	—	—	28	—	30/35
	CE20Y	1	19.2	65.5	18.5	28	30/35	—	24	25	—	—
	CE40Y	2	38.4	131	37	51	60/60	—	47	50	—	—
	CE60Y	2	57.6	196.5	55.4	74	80/80	—	70	70	—	—
C210YL	CE75Y	2	72	245.63	69.3	92	100/100	—	87	90	—	—
	No Heat	—	—	—	—	35	40/45	—	—	—	—	40/45
	CE20Y	1	19.2	65.5	18.5	35	40/45	—	24	25	—	—
	CE40Y	2	38.4	131	37	51	60/60	—	47	50	—	—
C240YL	CE60Y	2	57.6	196.5	55.4	74	80/80	—	70	70	—	—
	CE75Y	2	72	245.63	69.3	92	100/100	—	87	90	—	—
	No Heat	—	—	—	—	40	45/50	—	—	—	—	45/50
	CE20Y	1	19.2	65.5	18.5	40	45/50	—	24	25	—	—
C180YM	CE40Y	2	38.4	131	37	53	60/60	—	47	50	—	—
	CE60Y	2	57.6	196.5	55.4	76	80/80	—	70	70	—	—
	CE75Y	2	72	245.63	69.3	94	100/100	—	87	90	—	—
	No Heat	—	—	—	—	30	35/35	—	—	—	—	35/35
C210YM	CE20Y	1	19.2	65.5	18.5	30	35/35	—	24	25	—	—
	CE40Y	2	38.4	131	37	53	60/60	—	47	50	—	—
	CE60Y	2	57.6	196.5	55.4	76	80/80	—	70	70	—	—
	CE75Y	2	72	245.63	69.3	94	100/100	—	87	90	—	—
C240YM	No Heat	—	—	—	—	37	40/45	—	—	—	—	40/45
	CE20Y	1	19.2	65.5	18.5	37	40/45	—	24	25	—	—
	CE40Y	2	38.4	131	37	53	60/60	—	47	50	—	—
	CE60Y	2	57.6	196.5	55.4	76	80/80	—	70	70	—	—
C240YN	CE75Y	2	72	245.63	69.3	94	100/100	—	87	90	—	—
	No Heat	—	—	—	—	42	50/50	—	—	—	—	50/50
	CE20Y	1	19.2	65.5	18.5	42	50/50	—	24	25	—	—
	CE40Y	2	38.4	131	37	56	60/60	—	47	50	—	—
C240Y	CE60Y	2	57.6	196.5	55.4	80	80/80	—	70	70	—	—
	CE75Y	2	72	245.63	69.3	97	100/100	—	87	90	—	—
	No Heat	—	—	—	—	42	50/50	—	—	—	—	50/50
	CE20Y	1	19.2	65.5	18.5	42	50/50	—	24	25	—	—
C240Y	CE40Y	2	38.4	131	37	56	60/60	—	47	50	—	—
	CE60Y	2	57.6	196.5	55.4	80	80/80	—	70	70	—	—
	CE75Y	2	72	245.63	69.3	97	100/100	—	87	90	—	—
	No Heat	—	—	—	—	42	50/50	—	—	—	—	50/50

* = For Canadian use only. Uses "rp" fuses for inductive circuit.
 + = Field installed only.

208/240 VOLT, THREE PHASE, 60 HZ, AUXILIARY ELECTRIC HEATER KITS CHARACTERISTICS AND APPLICATION														
Single Power Supply for Both Unit and Heater Kit						Separate Power Supply for Both Unit and Heater Kit								
Model No. RLNL-	RXJJ-Heater Kit Nominal kW	No. of Sequence Steps	Heater Kit			Air Conditioner			Heater Kit			Air Conditioner		
			Rated Heater kW @ 208/240V	Heater kBTU/Hr @ 208/240V	Heater Amps @ 208/240V	Unit Min. Ckt. Ampacity @ 208/240V	Over Current Protective Device Size		Min. Ckt. Ampacity 208/240V	Max. Fuse Size 208/240V	Min. Circuit Ampacity 208/240V	Over Current Protective Device Size		
							Min./Max. 208V	Min./Max. 240V				Min./Max. 208V	Min./Max. 240V	
C241CL	No Heat	—	—	—	—	95/95	110/110	110/110	—	—	95/95	110/110	110/110	
	CE20C	14.4/19.2	49.13/65.5	40/46.2	95/95	110/110	110/110	50/58	50/60	103/103	110/110	110/110		
	CE40C	28.8/38.3	98.25/130.66	79.9/92.2	119/134	125/125	150/150	100/116	100/125	103/103	110/110	110/110		
	CE60C	43.2/57.5	147.38/196.16	119.9/138.3	169/192	175/175	200/200	150/173	150/175	103/103	110/110	110/110		
	CE75C	54/71.9	184.22/245.29	149.8/172.8	206/235	225/225	250/250	188/217	200/225	103/103	110/110	110/110		
C241CM	No Heat	—	—	—	103/103	125/125	125/125	—	—	103/103	125/125	125/125		
	CE20C	14.4/19.2	49.13/65.5	40/46.2	103/103	125/125	125/125	50/58	50/60	103/103	125/125	125/125		
	CE40C	28.8/38.3	98.25/130.66	79.9/92.2	129/145	150/150	150/150	100/116	100/125	103/103	125/125	125/125		
	CE60C	43.2/57.5	147.38/196.16	119.9/138.3	179/202	200/200	225/225	150/173	150/175	103/103	125/125	125/125		
	CE75C	54/71.9	184.22/245.29	149.8/172.8	217/245	225/225	250/250	188/217	200/225	103/103	125/125	125/125		

480 VOLT, THREE PHASE, 60 HZ, AUXILIARY ELECTRIC HEATER KITS CHARACTERISTICS AND APPLICATION														
Single Power Supply for Both Unit and Heater Kit						Separate Power Supply for Both Unit and Heater Kit								
Model No. RLRL-	RXJJ-Heater Kit Nominal kW	No. of Sequence Steps	Heater Kit			Air Conditioner			Heater Kit			Air Conditioner		
			Rated Heater kW @ 480V	Heater kBTU/Hr @ 480V	Heater Amps @ 480V	Unit Min. Ckt. Ampacity @ 480V	Over Current Protective Device Size		Min. Circuit Ampacity 480V	Max. Fuse Size 480V	Min. Circuit Ampacity 480V	Over Current Protective Device Size		
							Min./Max. 480V	Min./Max. 480V				Min./Max. 480V	Min./Max. 480V	
C241DL	No Heat	—	—	—	—	49	60/60	—	—	—	—	60/60		
	CE20D	19.2	65.5	23.1	49	60/60	60/60	29	30	—	—	—		
	CE40D	38.4	131	46.2	67	70/70	70/70	58	60	—	—	—		
	CE60D	57.6	196.5	69.3	95	100/100	100/100	87	90	—	—	—		
	CE75D	72	245.63	86.6	117	125/125	125/125	109	110	—	—	—		
C241DM	No Heat	—	—	—	52	60/60	—	—	—	52	—	60/60		
	CE20D	19.2	65.5	23.1	52	60/60	60/60	29	30	—	—	—		
	CE40D	38.4	131	46.2	70	70/70	70/70	58	60	—	—	—		
	CE60D	57.6	196.5	69.3	99	100/100	100/100	87	90	—	—	—		
	CE75D	72	245.63	86.6	121	125/125	125/125	109	110	—	—	—		

600 VOLT, THREE PHASE, 60 HZ, AUXILIARY ELECTRIC HEATER KITS CHARACTERISTICS AND APPLICATION																		
Separate Power Supply for Both Unit and Heater Kit																		
Single Power Supply for Both Unit and Heater Kit																		
Model No. RLRL-	RXJJ-Heater Kit Nominal kW	No. of Sequence Steps	Heater Kit				Air Conditioner				Heater Kit		Air Conditioner					
			Rated Heater kW @ 600V	Heater kBTU/Hr @ 600V	Heater Amps @ 600V	Unit Min. Ckt. Ampacity @ 600V	Over Current Protective Device Size Min./Max. 600V	Min. Ckt. Ampacity 600V	Max. Fuse Size 600V	Min. Circuit Ampacity 600V	Over Current Protective Device Size Min./Max. 600V							
C241YL	No Heat	—	—	—	—	37	40/45	—	—	—	—	—	—	—	—	—	—	—
	CE20Y	1	19.2	65.5	18.5	37	40/45	—	—	—	24	25	—	—	—	—	—	—
	CE40Y	2	38.4	131	37	53	60/60	—	—	—	47	50	—	—	—	—	—	—
	CE60Y	2	57.6	196.5	55.4	76	80/80	—	—	—	70	70	—	—	—	—	—	—
	CE75Y	2	72	245.63	69.3	94	100/100	—	—	—	87	90	—	—	—	—	—	—
C241YM	No Heat	—	—	—	—	39	45/50	—	—	—	—	—	—	—	—	—	—	—
	CE20Y	1	19.2	65.5	18.5	39	45/50	—	—	—	24	25	—	—	—	—	—	—
	CE40Y	2	38.4	131	37	57	60/60	—	—	—	47	50	—	—	—	—	—	—
	CE60Y	2	57.6	196.5	55.4	80	80/80	—	—	—	70	70	—	—	—	—	—	—
	CE75Y	2	72	245.63	69.3	97	100/100	—	—	—	87	90	—	—	—	—	—	—

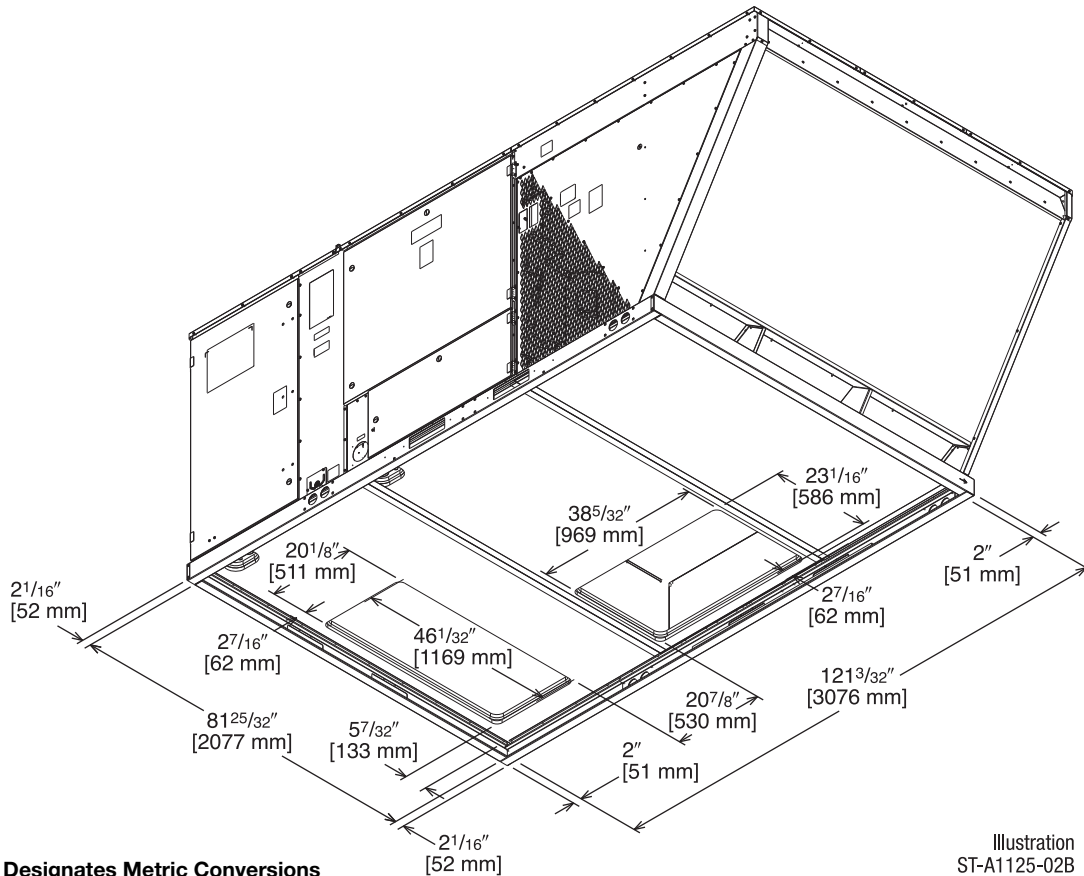
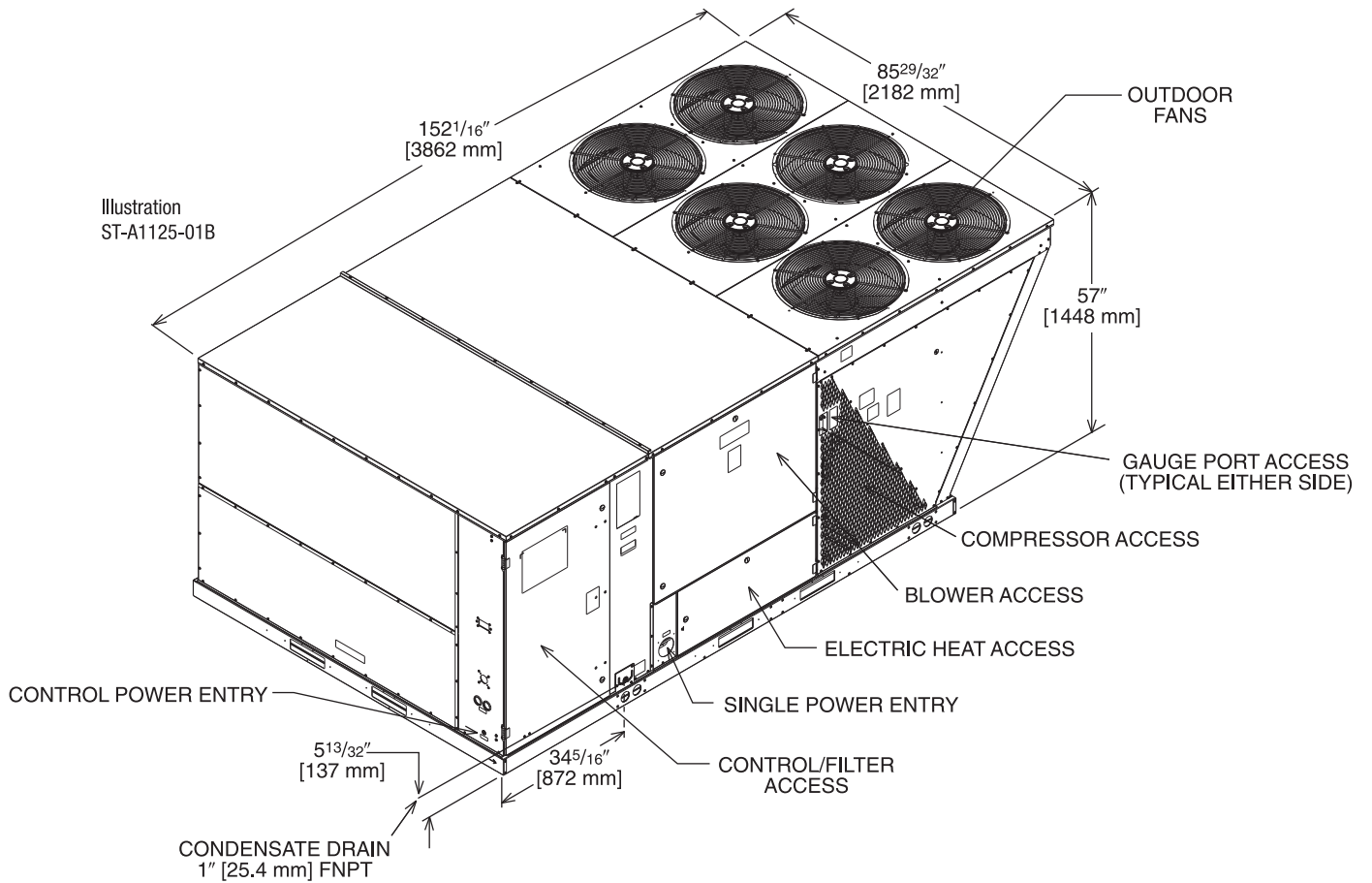

[] Designates Metric Conversions

Illustration
ST-A1125-02B

SUPPLY AND RETURN DIMENSIONS FOR HORIZONTAL APPLICATIONS

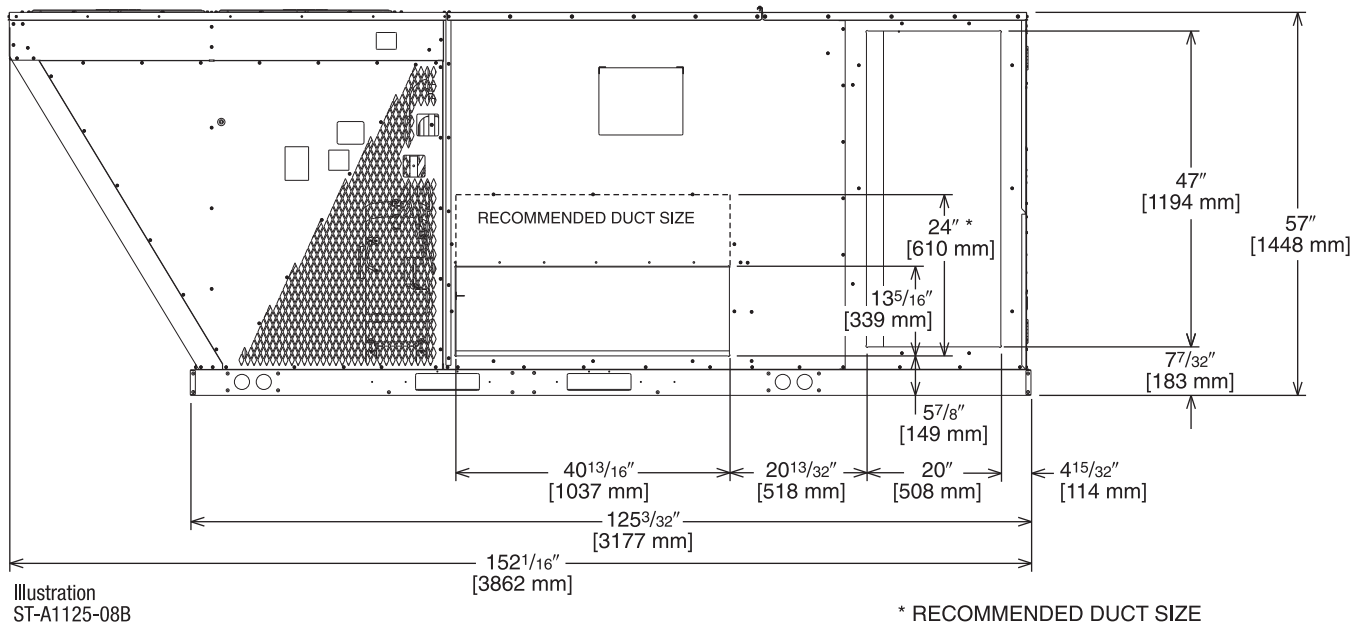

DUCT SIDE VIEW (REAR)

SUPPLY AND RETURN DIMENSIONS FOR DOWNFLOW APPLICATIONS

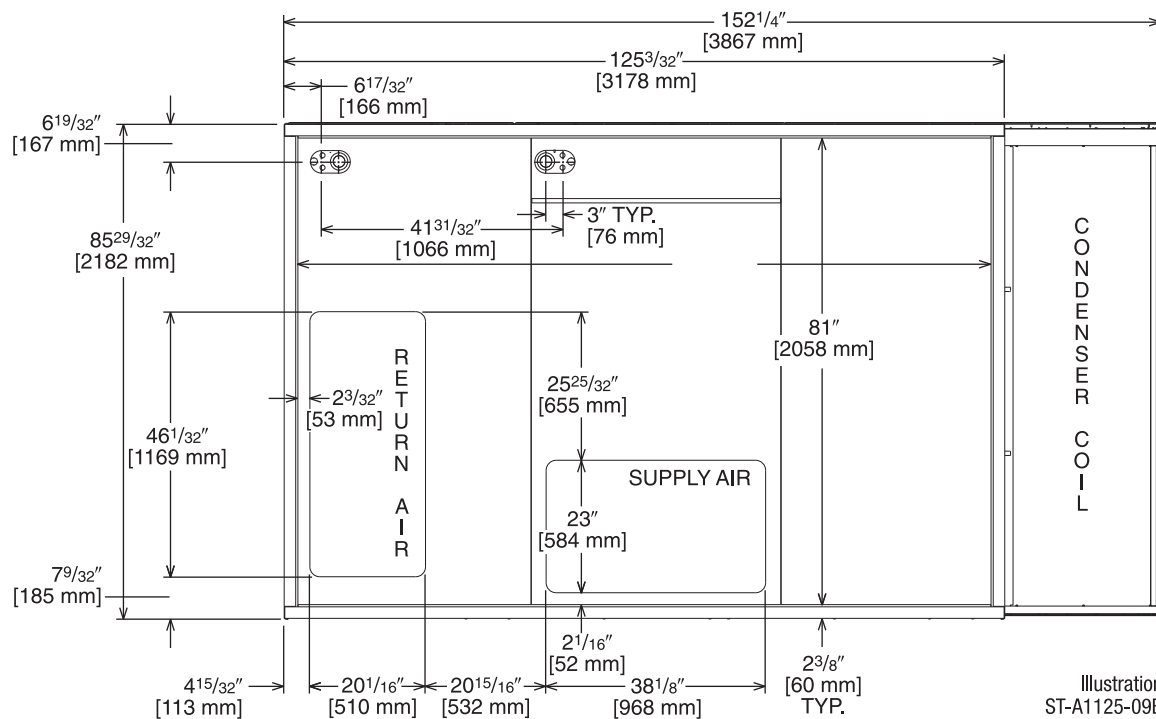

BOTTOM VIEW

[] Designates Metric Conversions

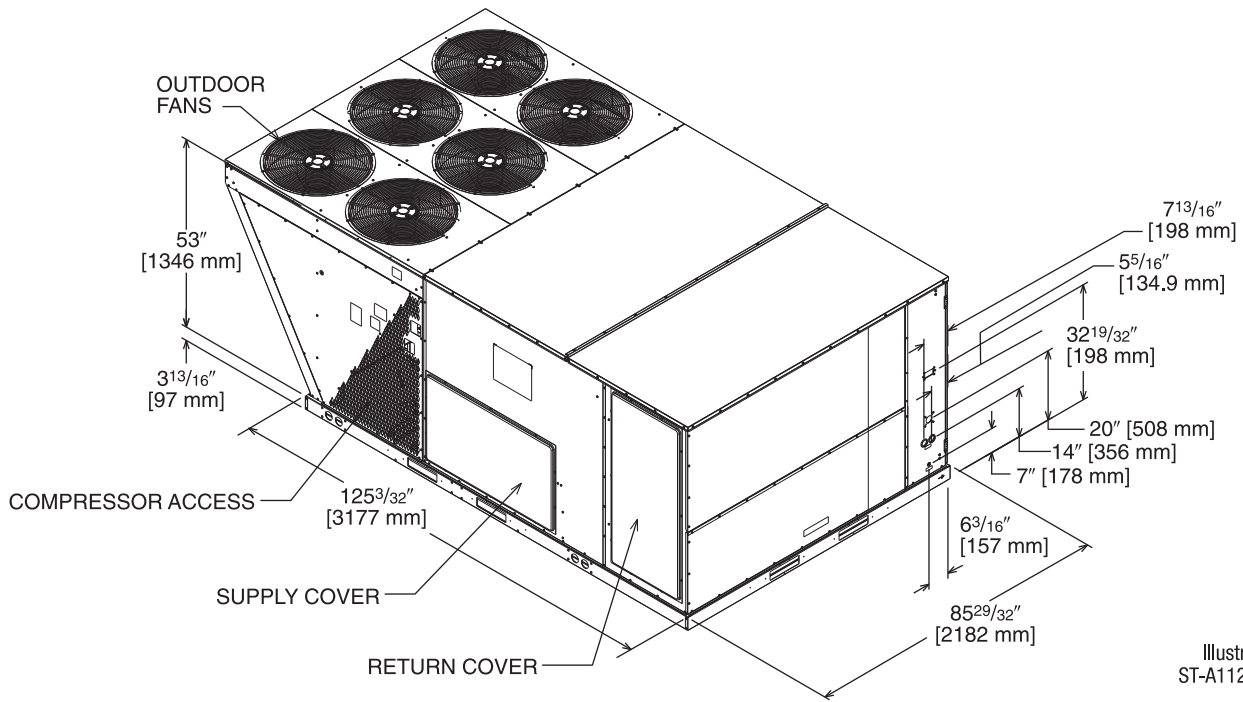
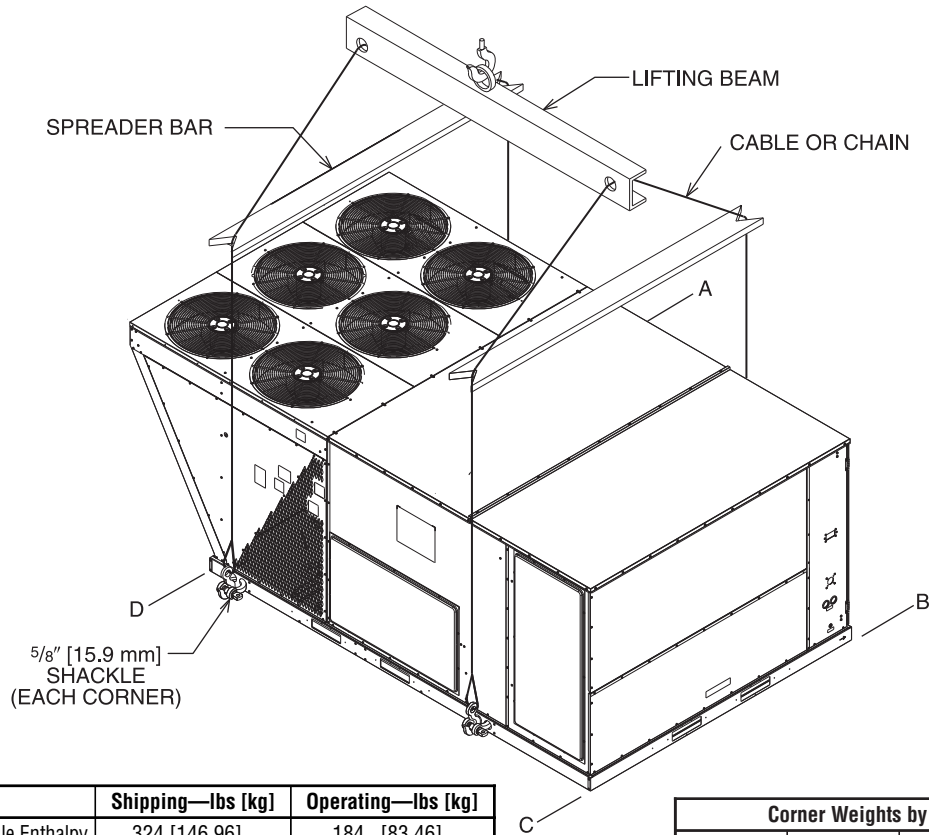

Illustration
ST-A1125-03



WEIGHTS*

Accessory	Shipping—lbs [kg]	Operating—lbs [kg]
Downflow Economizer w/DDC Single Enthalpy	324 [146.96]	184 [83.46]
Downflow Economizer w/DDC Smoke Detector	328 [148.77]	188 [85.27]
Horizontal Economizer w/DDC Single Enthalpy	367 [166.46]	258 [117.02]
Power Exhaust	44 [19.96]	42 [19.05]
Fresh Air Damper (Manual)	51 [23.13]	40 [18.14]
Fresh Air Damper (Motorized)	46 [20.87]	35 [15.88]
Roof Curb 14"	170 [77.11]	164 [74.39]

Corner Weights by Percentage			
A	B	C	D
32%	27%	16%	24%

*Note: Corner weights measured at base of unit.

[] Designates Metric Conversions

*Include options from accessory table page to obtain total unit weight.

SLAB INSTALLATION

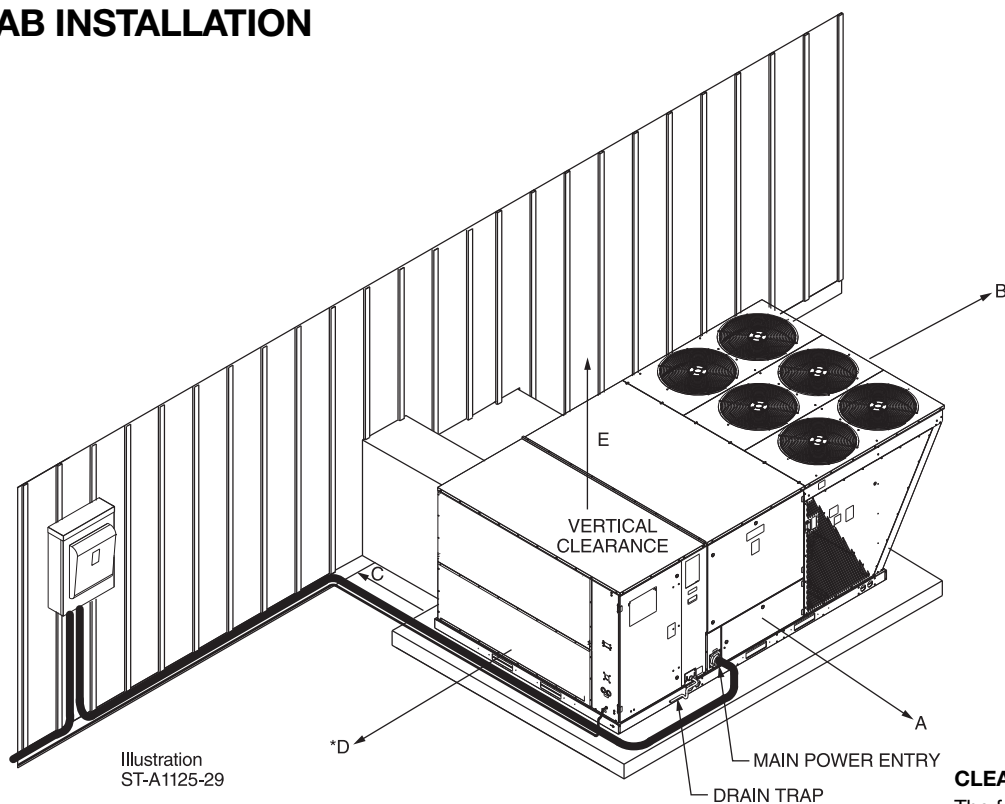

Illustration
ST-A1125-29

CLEARANCES

The following minimum clearances are recommended for proper unit performance and serviceability.

Recommended Clearance In. [mm]	Location
80 [2032]	A - Front
18 [457]	B - Condenser Coil
18 [457]	*C - Duct Side
18 [457]	*D - Evaporator End
60 [1524]	E - Above
*Without Economizer 18" [457 mm]. With Economizer 48" [1219 mm]. +Without Horizontal Economizer 18" [457 mm]. With Horizontal Economizer 42" [1067 mm].	

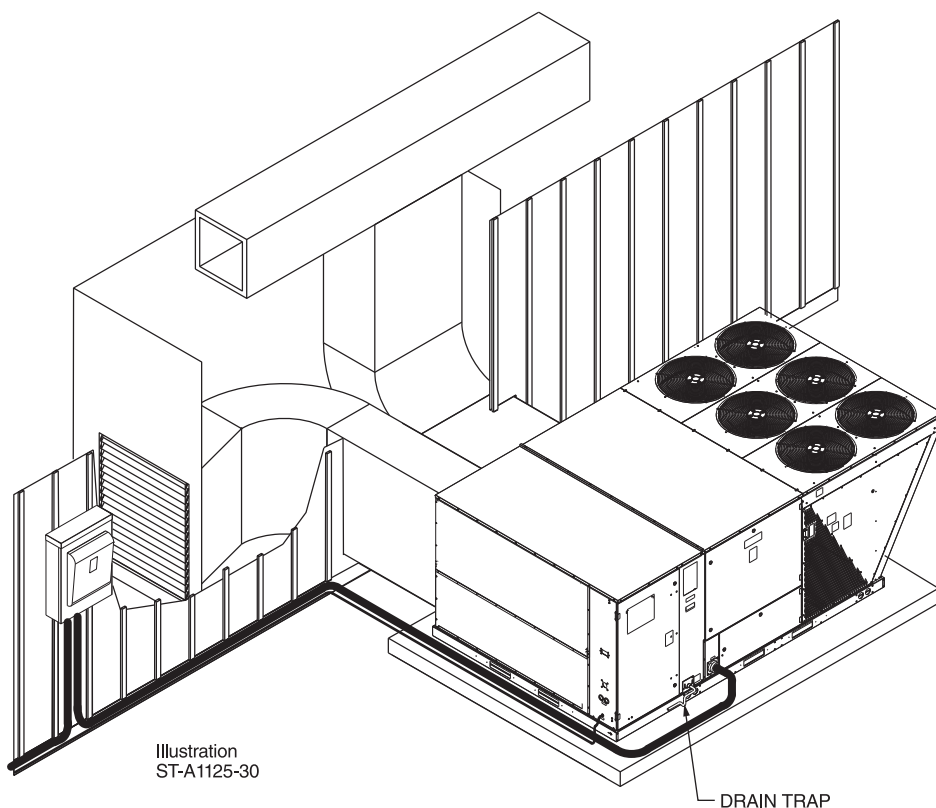

Illustration
ST-A1125-30

[] Designates Metric Conversions

FIELD INSTALLED ACCESSORY EQUIPMENT–SELF CONTAINED AIR CONDITIONER

New Descriptions	Model Number	Shipping Weight Lbs. [kg]	Installed Weight Lbs. [kg]	Factory Installation Available?
	RLNL-C180 thru C300			
Electric Heaters	RXJJ-CE20 (C,D,Y)	41 [18.6]	31 [14.1]	Yes
	RXJJ-CE40 (C,D,Y)	44 [20.0]	34 [15.4]	Yes
	RXJJ-CE60 (C,D,Y)	45 [20.4]	35 [15.9]	Yes
	RXJJ-CE75 (C,D,Y)	46 [20.8]	36 [16.3]	Yes
Downflow Economizer w/Single Enthalpy	AXRD-01RMDCM3	324 [149.6]	184 [83.4]	Yes
Downflow Economizer w/Smoke Detector	AXRD-01RMDDM3	328 [148.7]	188 [85.2]	Yes
Dual Enthalpy Kit	RXR-AR03	1 [.5]	.5 [.2]	No
Horizontal Economizer w/Single Enthalpy	AXRD-01RMHCM3	367 [166.4]	258 [117.0]	No
Carbon Dioxide Sensor (Wall Mount)	RXR-AR02	3 [1.4]	2 [1.0]	No
Power Exhaust (208/230V)	RXR-BGF05C	119 [53.9]	59 [26.7]	No
Power Exhaust (460V)	RXR-BGF05D	119 [53.9]	59 [26.7]	No
Power Exhaust (575V)	RXR-BGF05Y	119 [53.9]	59 [26.7]	No
Manual Fresh Air Damper*	AXRF-KFA1	61 [27.7]	52 [23.6]	No
Motorized Kit for Manual Fresh Air Damper*	RXR-AW03	42 [19.1]	35 [15.9]	No
Modulating Motor Kit w/position feedback for RXRF-KFA1*	RXR-AW05	45 [20.4]	38 [17.2]	No
Roofcurb, 14"	RXKG-CBH14	184 [83.5]	176 [79.8]	No
Roofcurb Adapter to RXRK-E56	RXR-CJCE56	465 [210.9]	415 [88.2]	No
Roofcurb Adapter to RXKG-CAF14	RXR-CJCF14	555 [251.7]	505 [229.1]	No
Concentric Diffuser (Step-Down, 18" x 36")	RXRN-AD81	310 [140.6]	157 [71.2]	No
Concentric Diffuser (Step-Down, 24" x 48")	RXRN-AD86	367 [166.4]	212 [96.1]	No
Concentric Diffuser (Step-Down, 28" x 60")	RXRN-AD88	410 [186.0]	370 [67.8]	No
Concentric Diffuser (Flush, 18" x 36")	RXRN-AD80	213 [96.6]	115 [52.2]	No
Downflow Transition (Rect. to Rect., 18" x 36")	RXMC-CJ07	81 [36.7]	74 [33.6]	No
Downflow Transition (Rect. to Rect., 24" x 48")	RXMC-CK08	81 [36.7]	74 [33.6]	No
Downflow Transition (Rect. to Rect., 28" x 60")	RXMC-CL09	81 [36.7]	74 [33.6]	No
Low-Ambient Control Kit (1 Per Compressor)	RXRZ-C02	3 [1.4]	2 [1.0]	Yes
Unwired Convenience Outlet	RXR-AN01	2 [1.0]	1.5 [.7]	Yes
Comfort Alert (1 Per Compressor)	RXR-AZ01	3 [1.4]	2 [1.0]	Yes
BACnet Communication Card	RXR-AY01	1 [0.5]	1 [0.5]	No
LonWorks Communication Card	RXR-AY02	1 [0.5]	1 [0.5]	No
Hail Guard Louvers	AXRX-AAD01L	55 [24.8]	45 [20.3]	Yes

*Motorized Kit and Manual Fresh Air Damper must be combined for a complete Motorized Outside Air Damper Selection.

[] Designates Metric Conversions

FLUSH MOUNT ROOM TEMPERATURE SENSORS FOR NETWORKED DDC APPLICATIONS



ROOM TEMPERATURE SENSOR RHC-ZNS1
with TIMED OVERRIDE BUTTON

10k Ω room temperature sensor transmits room temperature to DDC system. Timed override button allows tenant to change from unoccupied temperature setpoint to occupied temperature setpoint for a preset time.



ROOM TEMPERATURE SENSOR RHC-ZNS2
with TIMED OVERRIDE BUTTON and STATUS INDICATOR

10k Ω room temperature sensor transmits room temperature to DDC system. Timed override button allows tenant to change from unoccupied temperature setpoint to occupied temperature setpoint for a preset time. Status Indicator Light transmits ALARM flash code to occupied space.



ROOM TEMPERATURE SENSOR RHC-ZNS3
with SETPOINT ADJUSTMENT and TIMED OVERRIDE BUTTON

10k Ω room temperature sensor with setpoint adjustment transmits room temperature to DDC system along with desired occupied room temperature setpoint. Timed override button allows tenant to change from unoccupied temperature setpoint to occupied temperature setpoint for a preset time.

COMMUNICATION CARDS

Field Installed



BACnet® COMMUNICATION CARD RXXR-AY01

The field installed BACnet® Communication Card allows the RTU-C unit controller to communicate with a third party building management system that supports the BACnet Application Specific Controller device profile. The BACnet® Communication Module plugs onto the unit RTU-C controller and allows communication between the RTU-C and the BACnet MSTP network.



LonWorks® COMMUNICATION CARD RXXR-AY02

The field installed LonWorks® Communication Card allows the RTU-C unit controller to communicate with a third party building management system that supports the LonMark Space Comfort Controller (SCC) functional profile or LonMark Discharge Air Controller (DAC) functional profile. The LonMark Communication Module plugs onto the RTU-C controller and allows communication between the RTU-C and a LonWorks Network.

ECONOMIZERS—DOWNFLOW ONLY

Use to Select Field Installed Options Only

AXRD-01RMDCM3—Single Enthalpy (Outdoor) with DDC

AXRD-01RMDDM3—Single Enthalpy (Outdoor) w/Smoke Detector and DDC

RXXR-AR03—Optional Wall-Mounted CO₂ Sensor

RXXR-AV02—Dual Enthalpy Upgrade Kit

- Features **Honeywell** Controls
- Available Factory Installed or Field Accessory
- Gear Driven Direct Drive Actuator
- Fully Modulating (0-100%)
- Ultra Low Leak Dampers meet California Title 24 requirements
- Slip-In Design for Easy Installation
- Plug-In Polarized 12-pin & 4-pin Electrical Connections
- Pre-Configured—No Field Adjustments Necessary
- Standard Barometric Relief Damper
- Single Enthalpy with Dual Enthalpy Upgrade Kit Available
- CO₂ Input Sensor Available
- Field Assembled Hood Ships with Economizer
- Economizer Ships Complete for Downflow Duct Application.
- Optional Remote Minimum Position Potentiometer (270 ohm) (Honeywell #S963B1136) is Available from Prostock.
- Field Installed Power Exhaust Available
- If connected to a Building Automation System (BAS), all economizer functions can be viewed on the (BAS).

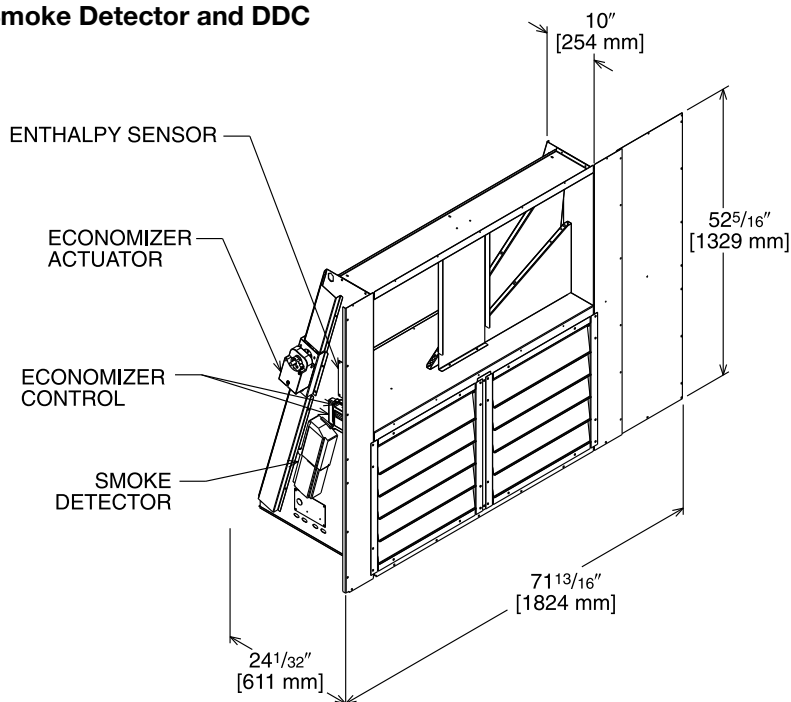

Illustration
ST-A00566-58

TOLERANCE ±.125

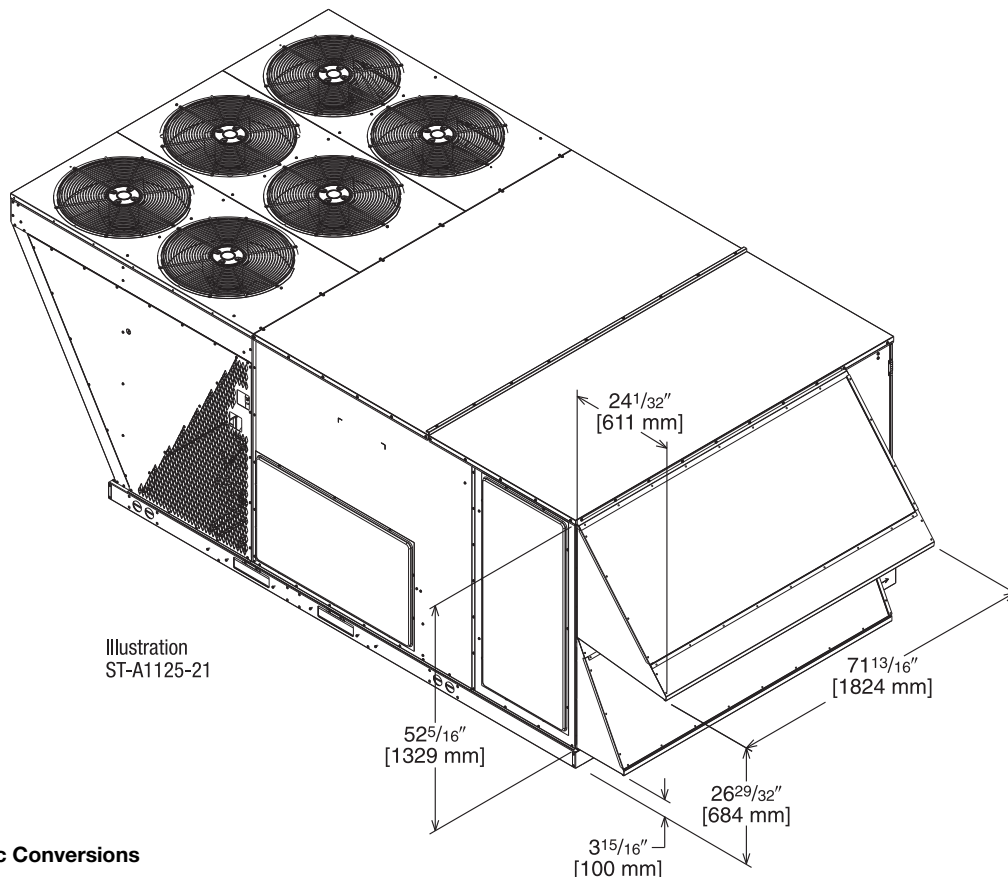

Illustration
ST-A1125-21

[] Designates Metric Conversions

ECONOMIZER FOR HORIZONTAL DUCT INSTALLATION

Field Installed Only

AXRD-01RMHCM3—Single Enthalpy (Outdoor) with DDC

RXXR-AV03—Dual Enthalpy Upgrade Kit

RXXR-AR02—Optional Wall-Mounted CO₂ Sensor

- Features **Honeywell** Controls
- Available as a Field Installed Accessory Only
- Gear Driven Direct Drive Actuator
- Fully Modulating (0-100%)
- Ultra Low Leak Dampers meet California Title 24 requirements
- Slip-In Design for Easy Installation
- Plug-In Polarized 12-pin and 4-pin Electrical Connections
- Pre-Configured—No Field Adjustments Necessary
- Standard Barometric Relief Damper
- Single Enthalpy with Dual Enthalpy Upgrade Kit Available
- CO₂ Input Sensor Available
- Field Assembled Hood Ships with Economizer
- Economizer Ships Complete for Horizontal Duct Application
- Optional Remote Minimum Position Potentiometer (270 ohm) (Honeywell #S963B1136) is available from Prostock
- Field Installed Power Exhaust Available
- If connected to a Building Automation System (BAS), all economizer functions can be viewed on the (BAS) or 16 x 2 LCD screen
- If connected to thermostat, all economizer functions can be viewed on 16 x 2 character LCD screen

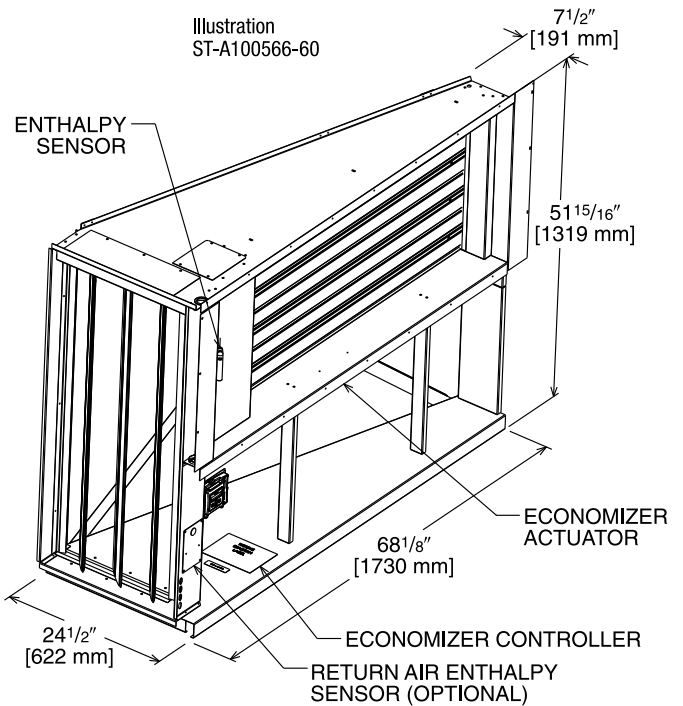

TOLERANCE ± .125

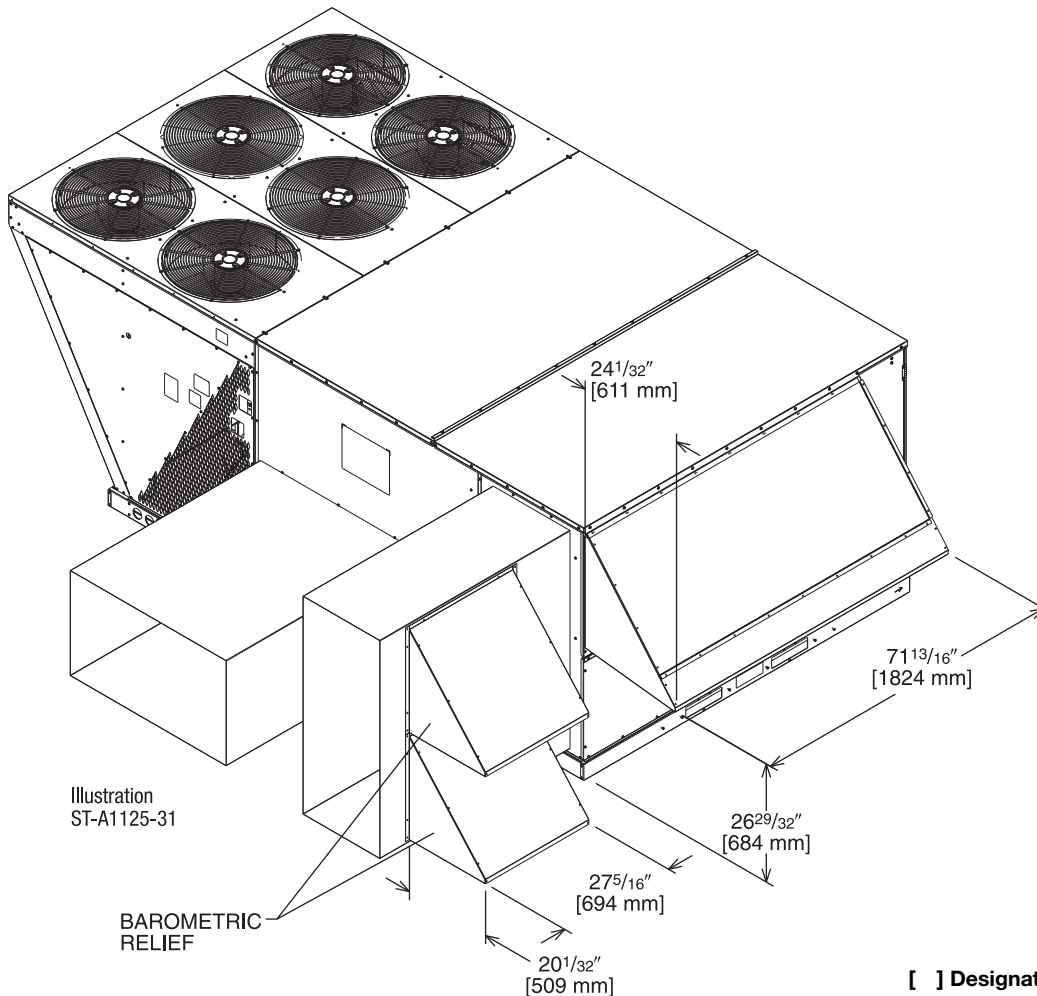

[] Designates Metric Conversions

INTEGRAL POWER EXHAUST KIT FOR AXRD-PMCM3 OR SMCM3 ECONOMIZERS

RXRX-BGF05 (C, D, or Y*)

*Voltage Code

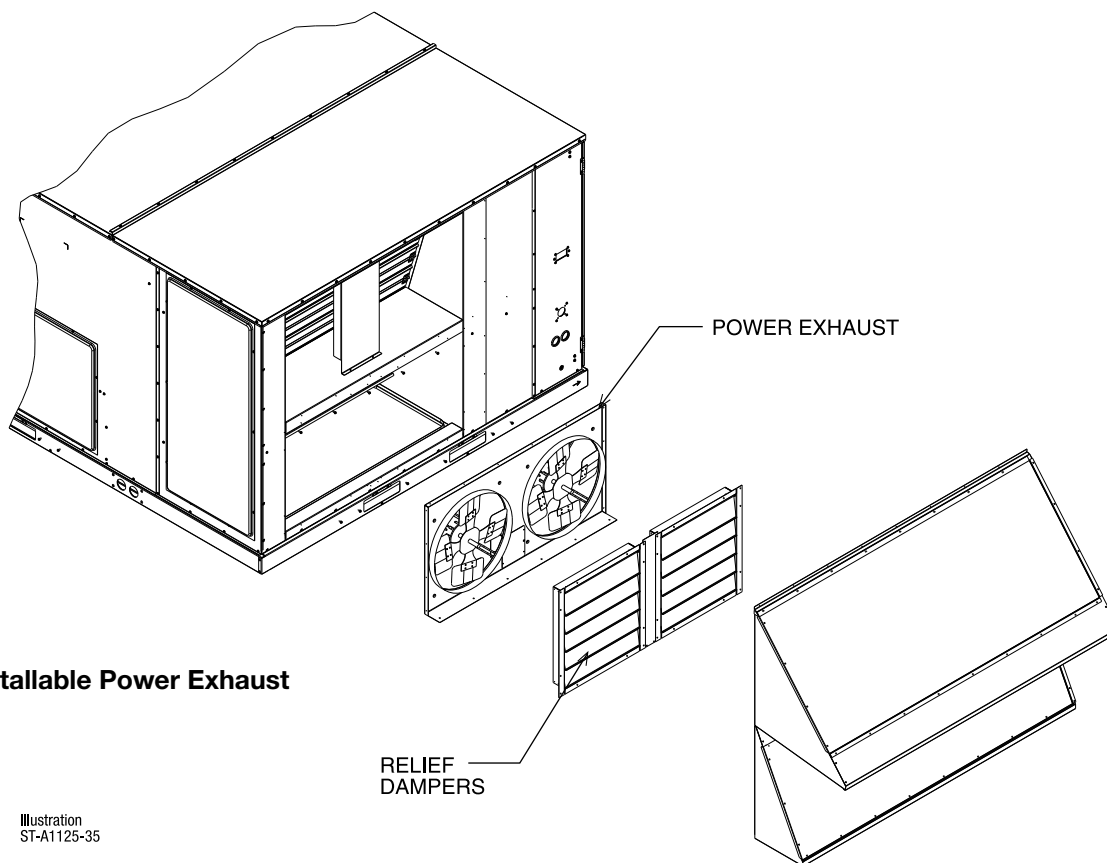

Field Installable Power Exhaust

Illustration
ST-A1125-35

Model No.	No. of Fans	Volts	Phase	HP (ea.)	Low Speed		High Speed ①		FLA (ea.)	LRA (ea.)
					CFM [L/s] ②	RPM	CFM [L/s] ②	RPM		
RXRX-BGF05C	2	208-230	1	0.75	4100 [1935]	850	5200 [2454]	1050	5	4.97
RXRX-BGF05D	2	460	1	0.75	4100 [1935]	850	5200 [2454]	1050	2.2	3.4
RXRX-BGF05Y	2	575	1	0.75	4100 [1935]	850	5200 [2454]	1050	1.5	2.84

NOTES: ① Power exhaust is factory set on high speed motor tap.

② CFM is per fan at 0" w.c. external static pressure.

[] Designates Metric Conversions

FRESH AIR DAMPER

MOTORIZED DAMPER KIT RXRX-AW03 (Motor Kit for AXRF-KFA1)

RXRX-AW05 (Modulating Motor Kit with position feedback for AXRF-KFA1)

- Features **Honeywell** Controls
- Gear Driven Direct Drive Actuator
- Fully Modulating (0-100%)
- Low Leakage Dampers
- Slip-In Design for Easy Installation
- Plug-In Polarized 12-pin and 4-pin Electrical Connections
- Pre-Configured — No Field Adjustments Necessary
- Addition of Dual Enthalpy Upgrade Kit allows limited economizer function
- CO₂ Sensor Input Available for Demand Control Ventilation (DCV)
- Optional Remote Minimum Position Potentiometer (270 ohm) (Honeywell #S963B1136) is available from Prostock
- All fresh air damper functions can be viewed at the RTU-C unit controller display
- If connected to a Building Automation System (BAS), all fresh air damper functions can be viewed on the (BAS), on 16 x 2 LCD screen
- If connected to thermostat, all fresh air damper functions can be viewed on 16 x 2 LCD screen

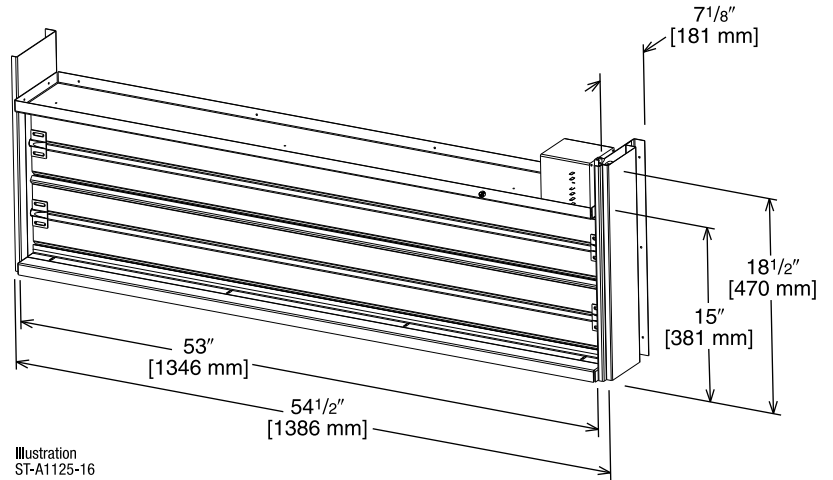

Illustration
ST-A1125-16

AXRF-KFA1 (Manual) RXRX-AW03 (Motorized damper kit for manual fresh air damper)

RXRX-AW05 (Modulating Motor Kit with position feedback for AXRF-KFA1)

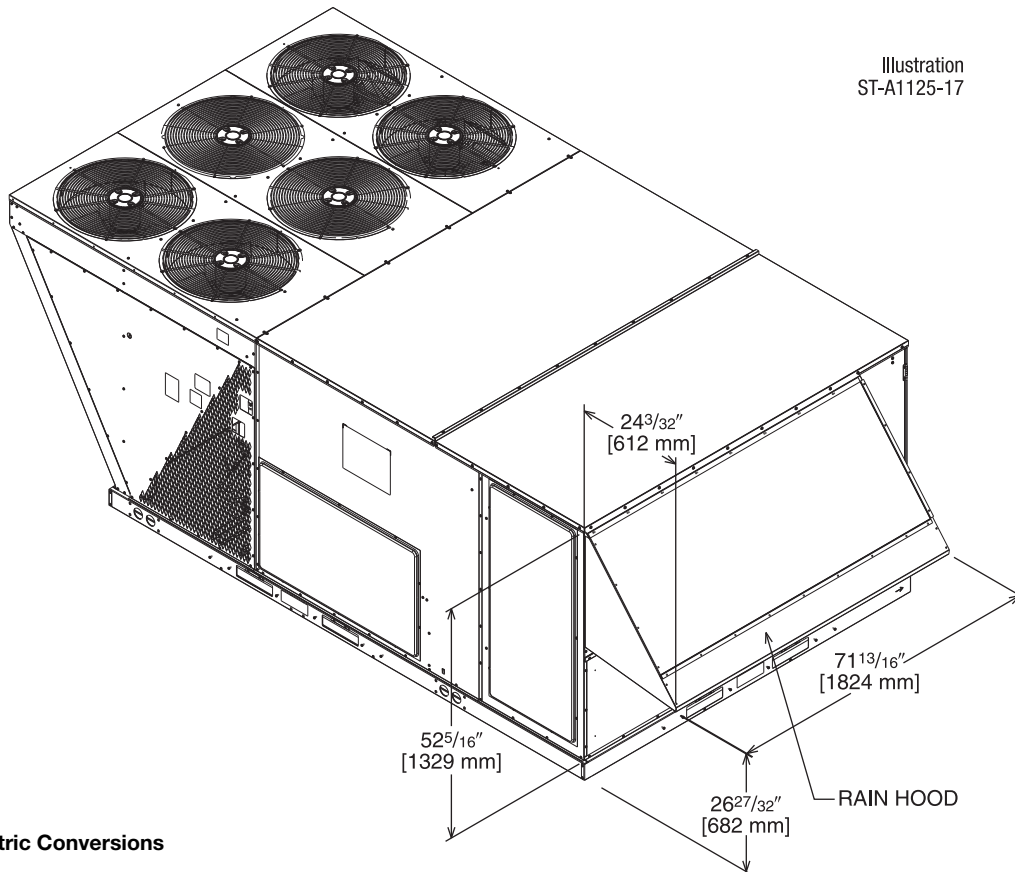

Illustration
ST-A1125-17

[] Designates Metric Conversions

ROOFCURBS (Full Perimeter)

- Rheem's roofcurb design can be utilized on 15, 17.5, 20 and 25 ton [52.8, 61.5, 70.3 and 87.9 kW] models.
- One available height (14" [356 mm]).
- Quick assembly corners for simple and fast assembly.
- 1" [25.4 mm] x 4" [102 mm] Nailers provided.
- Insulating panels not required because of insulated outdoor base pan.
- Sealing gasket (28" [711 mm]) provided with Roofcurb.
- Packaged for easy field assembly.

TYPICAL INSTALLATION

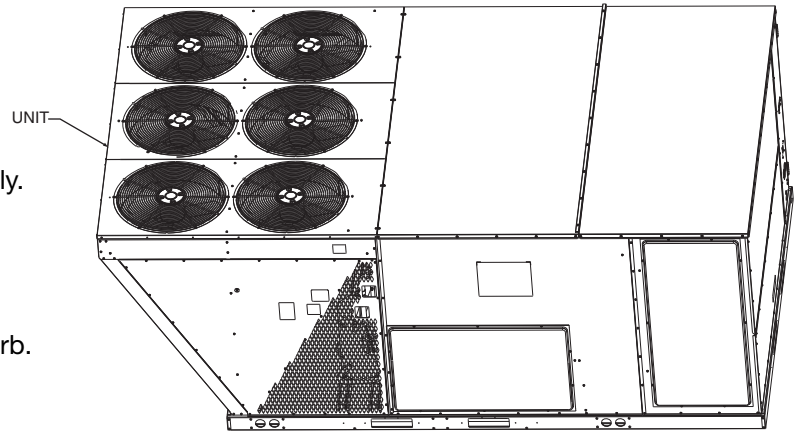

ROOFCURB ASSEMBLY

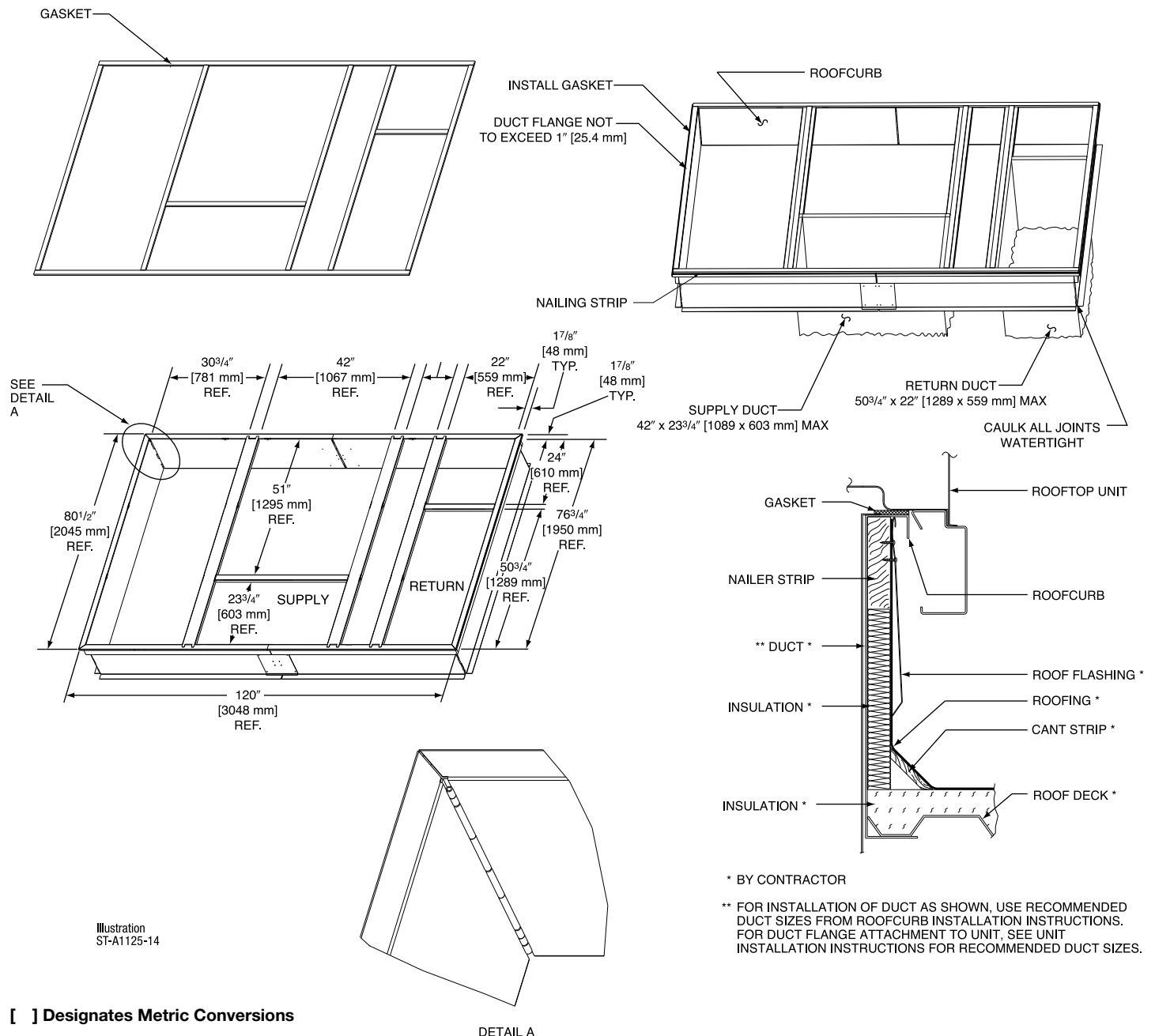

[] Designates Metric Conversions

ROOFCURB ADAPTERS

OLD MODELS

OLD CURB MODEL

ROOFCURB ADAPTER

NEW MODEL

COMMERCIAL CABINET
(12.5, 15 & 20 TON)
([44, 52.8 & 70.3 kW])
(-)RCF, (-)RGF, (-)REF

RXRK-E56

RXRK-CJCE56

RLNL-C/H
(15, 17.5, 20 & 25 TON)
([52.8, 61.5, 70.3 & 87.9 kW])

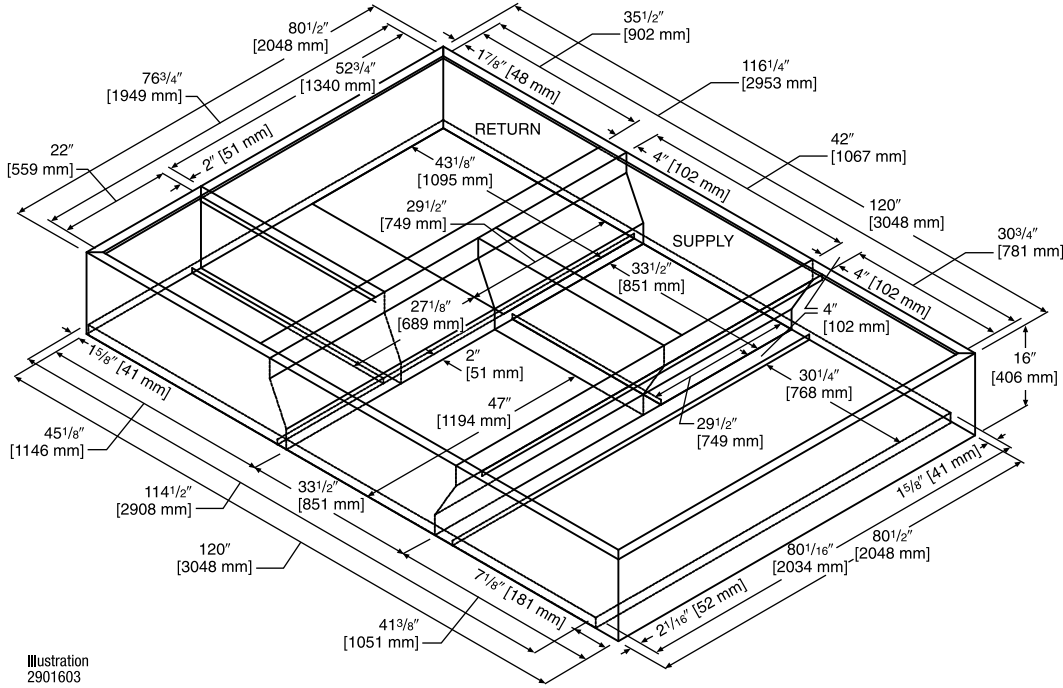

COMMERCIAL CABINET
(15, 20 & 25 TON)
([52.8, 70.3 & 87.9 kW])
(-)LKB, LMB, LNB

RXKG-CAF14

RXRK-CJCF14

RLNL-C/H
(15, 17.5, 20 & 25 TON)
([52.8, 61.5, 70.3 & 87.9 kW])

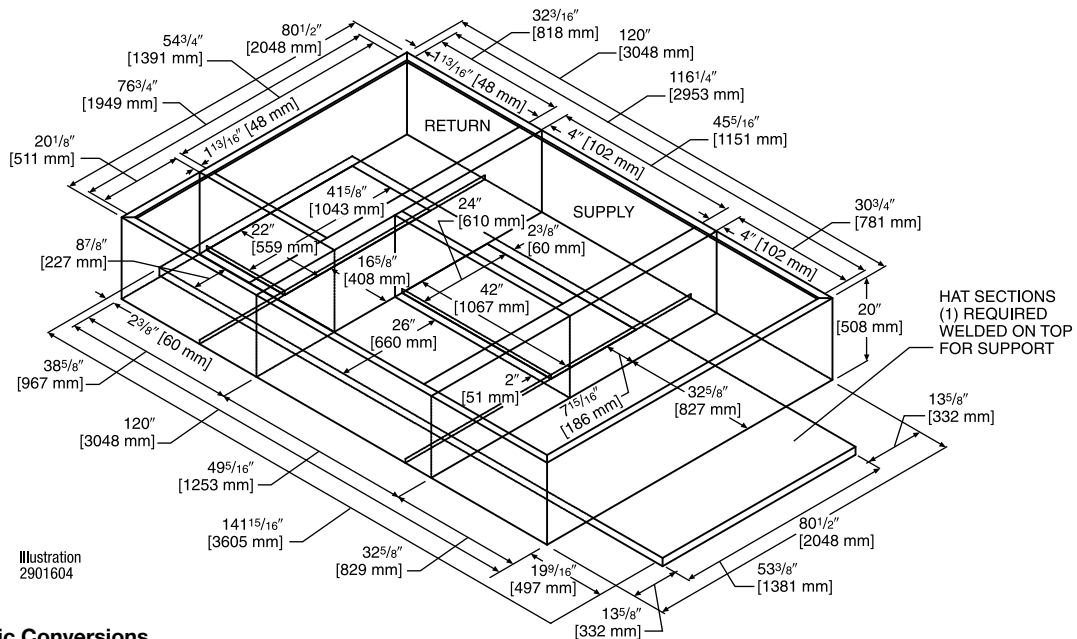

[] Designates Metric Conversions

CONCENTRIC DIFFUSER APPLICATION

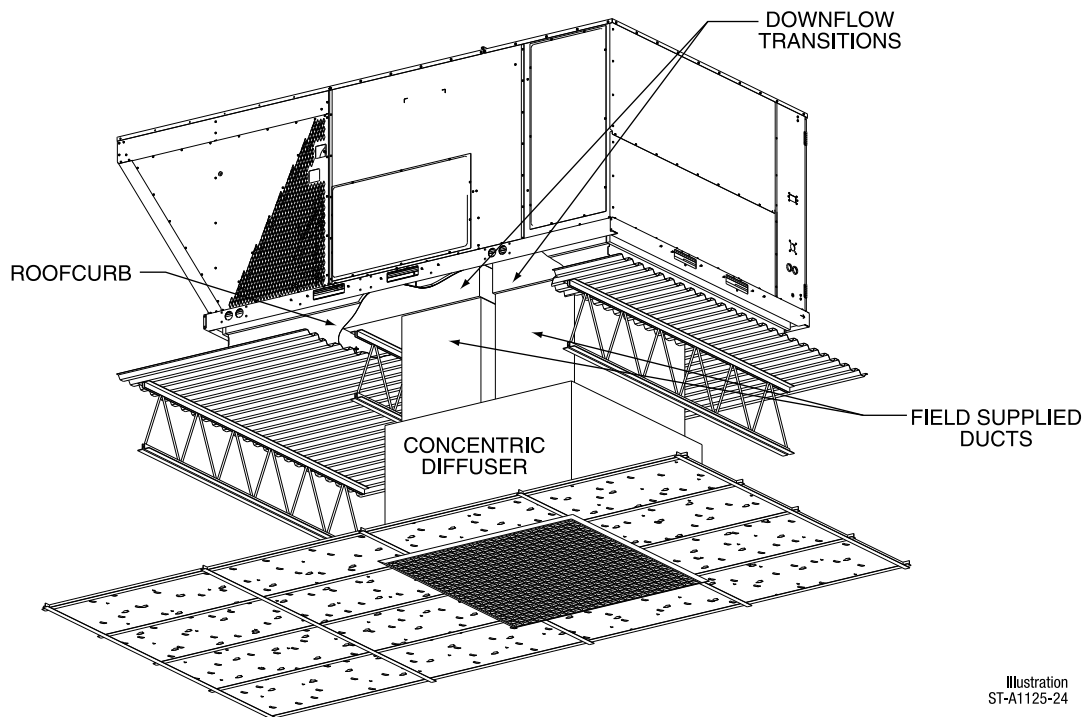

Illustration
ST-A1125-24

DOWNFLOW TRANSITION DRAWINGS

RXMC-CJ07 (15 Ton) [52.8 kW]

- Used with RXRN-AD80 and RXRN-AD81 Concentric Diffusers.

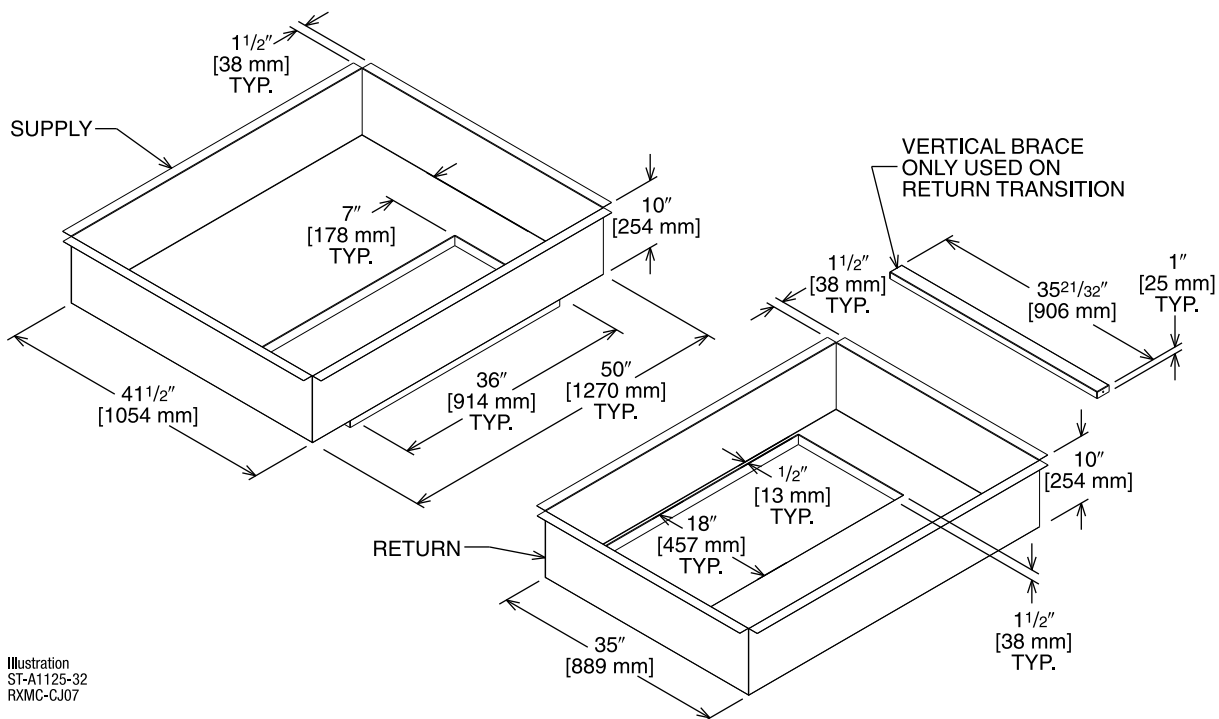

Illustration
ST-A1125-32
RXMC-CJ07

[] Designates Metric Conversions

DOWNFLOW TRANSITION DRAWINGS (Cont.)

RXMC-CK08 (20 Ton) [70.3 kW]

- Used with RXRN-AD86 Concentric Diffusers.

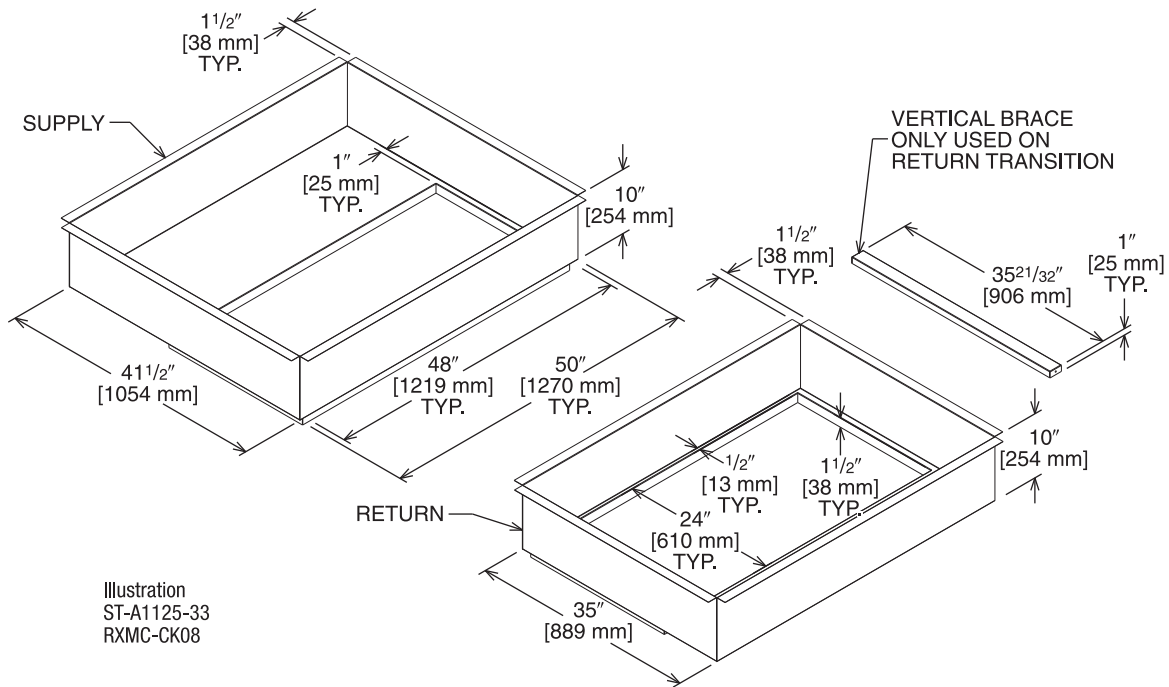

RXMC-CL09 (25 Ton) [87.9 kW]

- Used with RXRN-AD88 Concentric Diffusers.

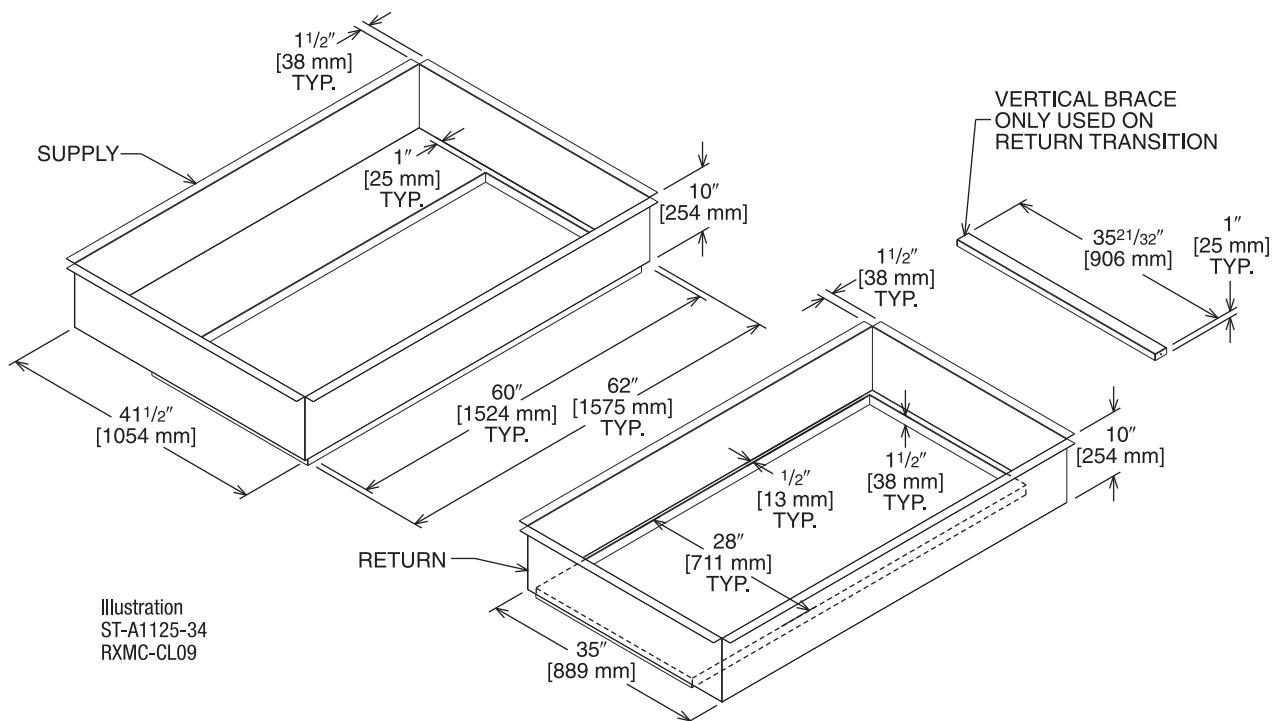

[] Designates Metric Conversions

CONCENTRIC DIFFUSER 15 TON [52.8 kW] FLUSH

- All aluminum diffuser with aluminum return air eggcrate.
- Built-in anti-sweat gasket.
- Molded fiberglass supports.
- Built-in hanging supports.
- Diffuser box constructed of sheetmetal insulated with 1" [25.4 mm] 1.5 lbs. [.7 kg] duct liner.

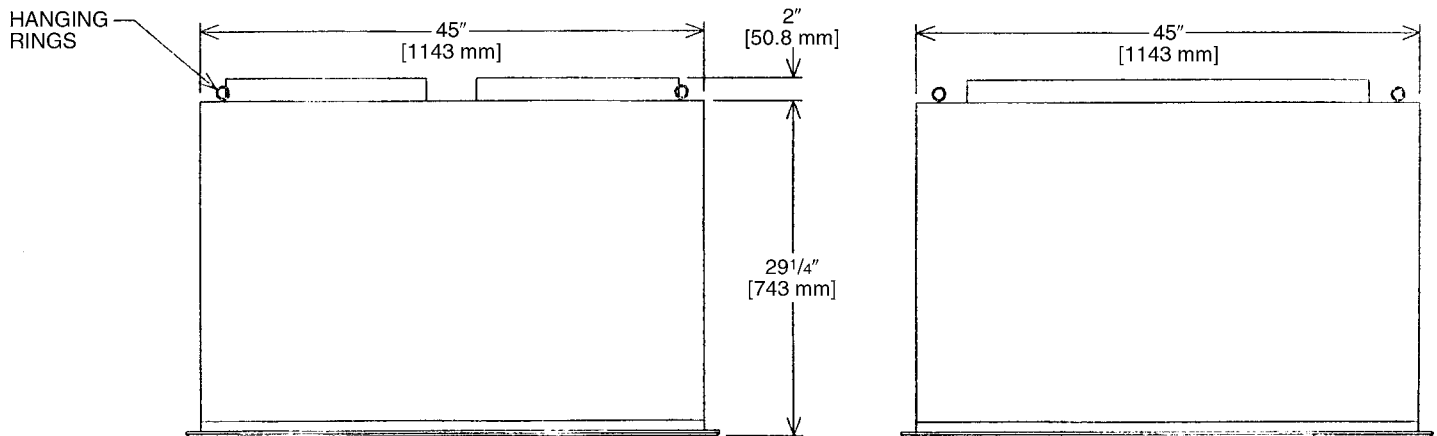
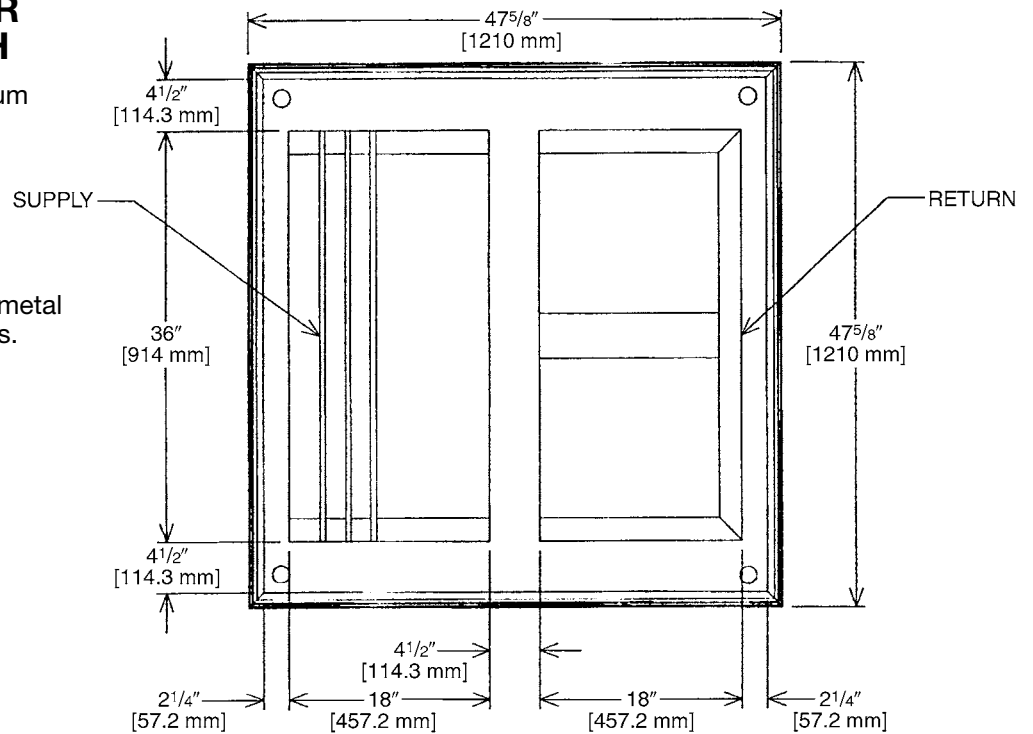

CONCENTRIC DIFFUSER SPECIFICATIONS

PART NUMBER	CFM [L/s]	STATIC PRESSURE	THROW FEET	NECK VELOCITY	JET VELOCITY
RXRN-AD80	5600 [2643]	0.36	28-37	1000	2082
	5800 [2737]	0.39	29-38	1036	2156
	6000 [2832]	0.42	40-50	1071	2230
	6200 [2926]	0.46	42-51	1107	2308
	6400 [3020]	0.50	43-52	1143	2379
	6600 [3115]	0.54	45-56	1179	2454

[] Designates Metric Conversions

CONCENTRIC DIFFUSER 15 TON [52.8 kW] STEP DOWN

- All aluminum diffuser with aluminum return air eggcrate.
- Built-in anti-sweat gasket.
- Molded fiberglass supports.
- Built-in hanging supports.
- Diffuser box constructed of sheetmetal insulated with 1" [25.4 mm] 1.5 lbs. [.7 kg] duct liner.
- Double deflection diffuser with the blades secured by spring steel.

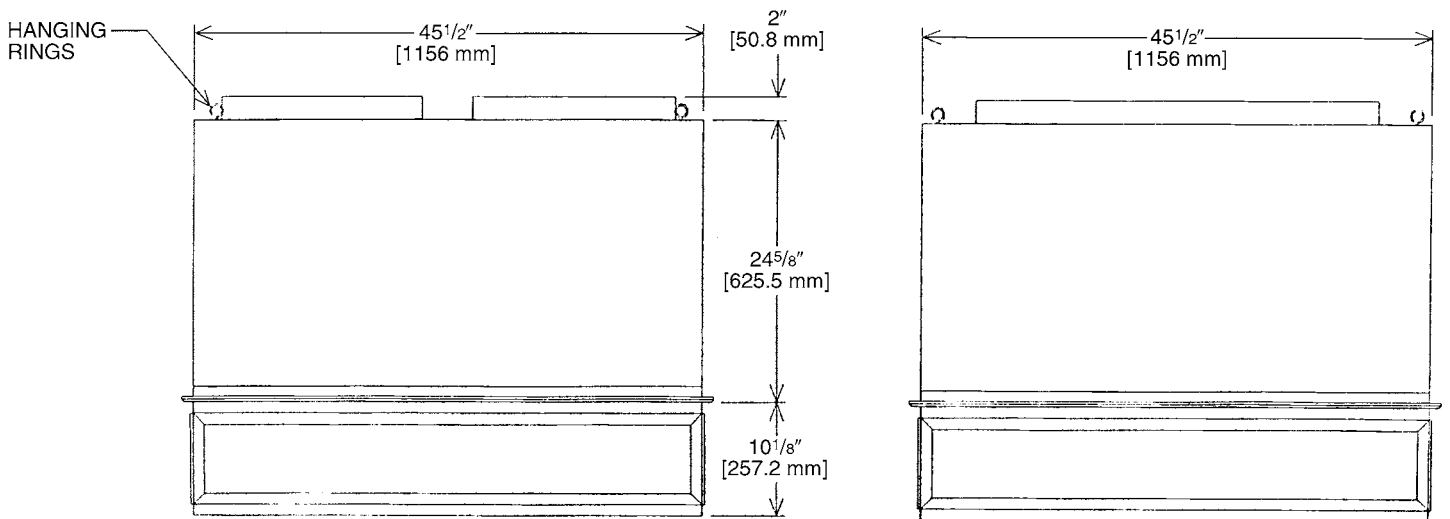
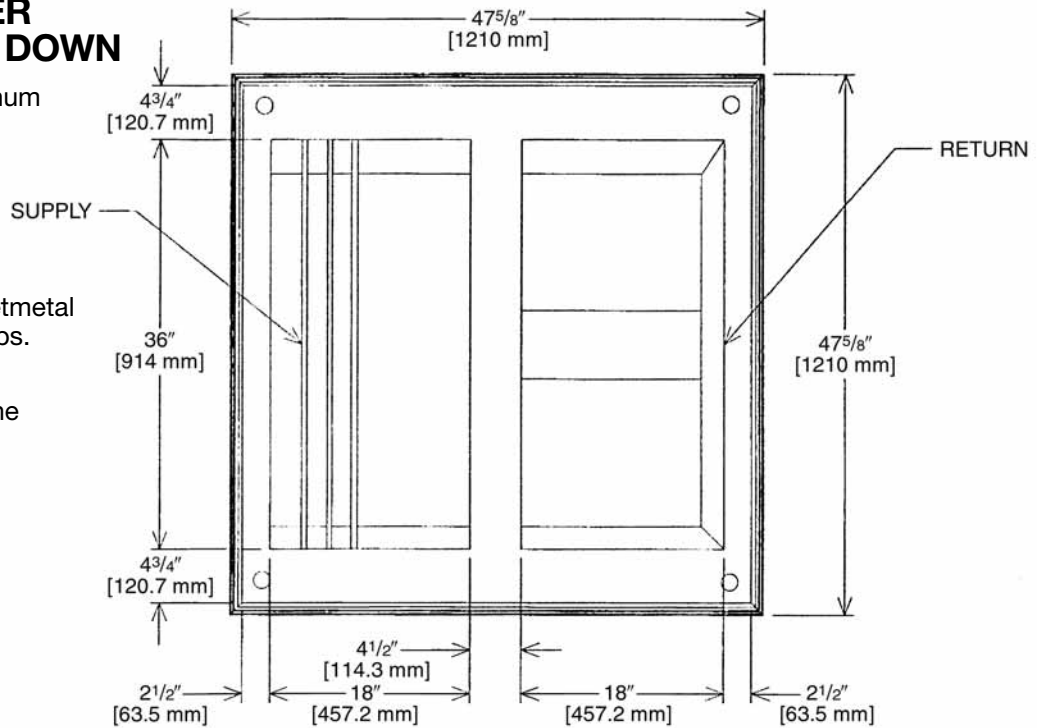

CONCENTRIC DIFFUSER SPECIFICATIONS

PART NUMBER	CFM [L/s]	STATIC PRESSURE	THROW FEET	NECK VELOCITY	JET VELOCITY
RXRN-AD81	5600 [2643]	0.36	39-49	920	920
	5800 [2737]	0.39	42-51	954	954
	6000 [2832]	0.42	44-54	1022	1022
	6200 [2926]	0.46	45-55	1056	1056
	6400 [3020]	0.50	46-55	1090	1090
	6600 [3115]	0.54	47-56	1124	1124

[] Designates Metric Conversions

CONCENTRIC DIFFUSER RXRN-AD86 SERIES 20 TON [70.3 kW] STEP DOWN

- All aluminum diffuser with aluminum return air eggcrate.
- Built-in anti-sweat gasket.
- Molded fiberglass supports.
- Built-in hanging supports.
- Diffuser box constructed of sheetmetal insulated with 1" [25.4 mm] 1.5 lbs. [.7 kg] duct liner.
- Double deflection diffuser with the blades secured by spring steel.

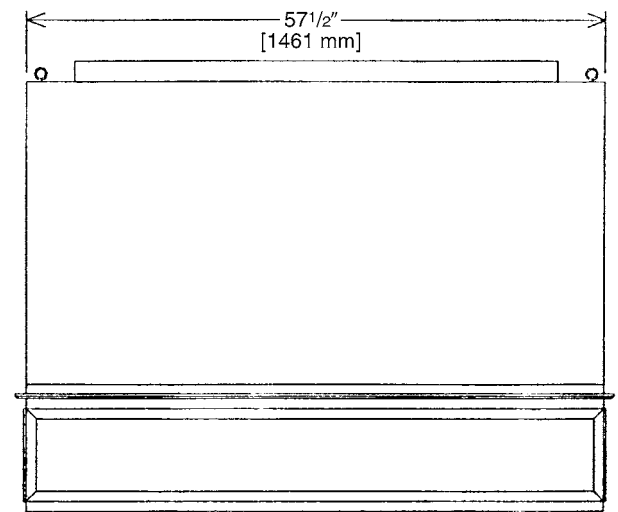
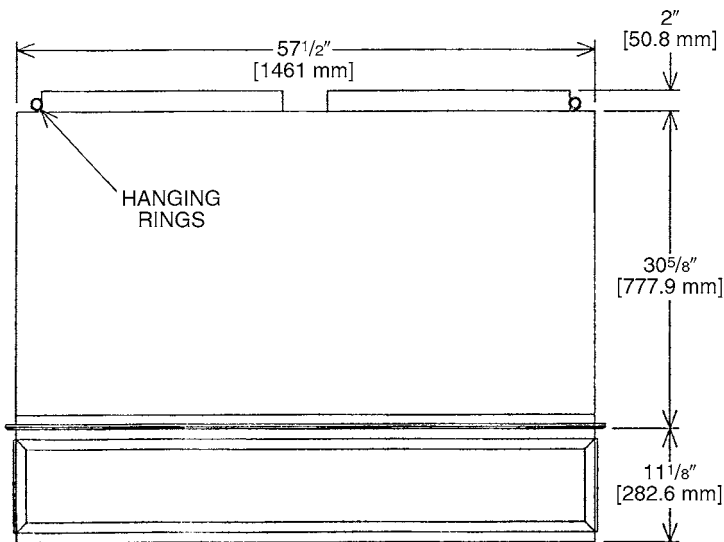
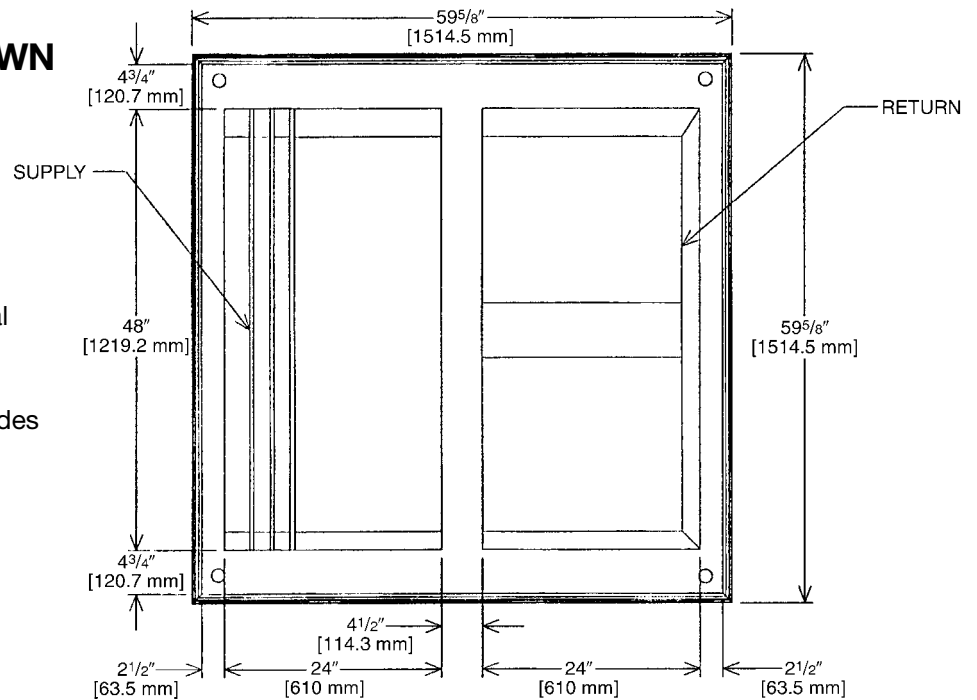

CONCENTRIC DIFFUSER SPECIFICATIONS

PART NUMBER	CFM [L/s]	STATIC PRESSURE	THROW FEET	NECK VELOCITY	JET VELOCITY
RXRN-AD86	7200 [3398]	0.39	33-38	827	827
	7400 [3492]	0.41	35-40	850	850
	7600 [3587]	0.43	36-41	873	873
	7800 [3681]	0.47	38-43	896	896
	8000 [3776]	0.50	39-44	918	918
	8200 [3870]	0.53	41-46	941	941
	8400 [3964]	0.56	43-49	964	964
	8600 [4059]	0.59	44-50	987	987
8800 [4153]	0.63	47-55	1010	1010	

[] Designates Metric Conversions

CONCENTRIC DIFFUSER RXRN-AD88 SERIES 25 TON [87.9 kW] STEP DOWN

- All aluminum diffuser with aluminum return air eggcrate.
- Built-in anti-sweat gasket.
- Molded fiberglass supports.
- Built-in hanging supports.
- Diffuser box constructed of sheetmetal insulated with 1" [25.4 mm] 1.5 lbs. [.7 kg] duct liner.
- Double deflection diffuser with the blades secured by spring steel.

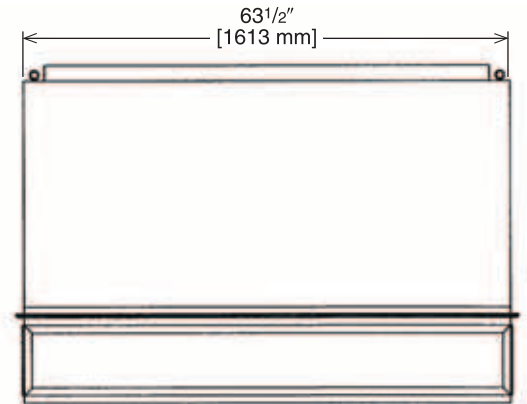
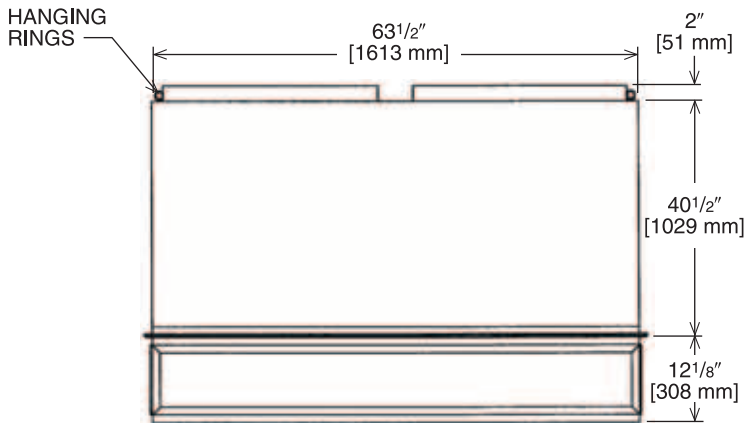
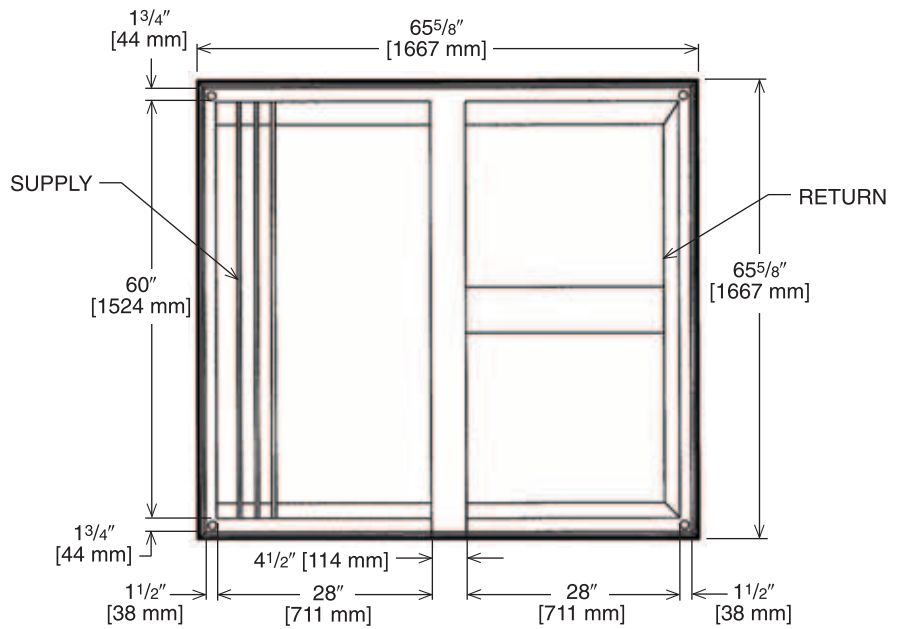

CONCENTRIC DIFFUSER SPECIFICATIONS

PART NUMBER	CFM [L/s]	STATIC PRESSURE	THROW FEET	NECK VELOCITY	JET VELOCITY
RXRN-AD88	10000 [4719]	0.51	46-54	907	907
	10500 [4955]	0.58	50-58	953	953
	11000 [5191]	0.65	53-61	998	998
	11500 [5427]	0.73	55-64	1043	1043
	12000 [5663]	0.82	58-67	1089	1089
	12500 [5898]	0.91	61-71	1134	1134
	13000 [6134]	1.00	64-74	1179	1179

[] Designates Metric Conversions

Guide Specifications – RLNL-C/H180 thru C/H300

You may copy this document directly into your building specification. This specification is written to comply with the 2004 version of the “master format” as published by the Construction Specification Institute. www.csinet.org.

ELECTRIC HEAT PACKAGED ROOFTOP

HVAC Guide Specifications

Size Range: 15 to 25 Nominal Tons

Section	Description
---------	-------------

23 06 80	Schedules for Decentralized HVAC Equipment
-----------------	---

23 06 80.13	Decentralized Unitary HVAC Equipment Schedule
-------------	---

23 06 80.13.A.	Rooftop unit schedule
----------------	-----------------------

1. Schedule is per the project specification requirements.

23 07 16	HVAC Equipment Insulation
-----------------	----------------------------------

23 07 16.13	Decentralized, Rooftop Units:
-------------	-------------------------------

1. Interior cabinet surfaces shall be insulated with a minimum 3/4-in. thick, minimum 1-1/2 lb density, flexible fiberglass insulation bonded with a phenolic binder, with aluminum foil facing on the air side.

2. Insulation and adhesive shall meet NFPA 90A requirements for flame spread and smoke generation.

23 09 13	Instrumentation and Control Devices for HVAC
-----------------	---

23 09 13.23	Sensors and Transmitters
-------------	--------------------------

23 09 13.23.A.	Thermostats
----------------	-------------

1. Thermostat must

- a. have capability to energize 2 different stages of cooling, and 2 different stages of heating.

- b. must include capability for occupancy scheduling.

23 09 23	Direct-digital Control system for HVAC
-----------------	---

23 09 23.13	Decentralized, Rooftop Units:
-------------	-------------------------------

23 09 23.13.A.	RTU-C controller
----------------	------------------

1. Shall be ASHRAE 62-2001 compliant.

2. Shall accept 18-32VAC input power.

3. Shall have an operating temperature range from -40°F (-40°C) to 158°F (70°C), 10% - 95% RH (non-condensing).

4. Controller shall accept the following inputs: space temperature, setpoint adjustment, outdoor air temperature, indoor air quality, outdoor air enthalpy, fire shutdown, return air enthalpy, fan status, remote time clock/door switch.

5. Shall accept a CO₂ sensor in the conditioned space, and be Demand Control Ventilation (DCV) ready.

6. Shall provide the following outputs: Economizer, fan, cooling stage 1, cooling stage 2, heat stage 1, heat stage 2, exhaust, occupied.

7. Unit shall provide surge protection for the controller through a circuit breaker.

8. Shall have a field installed communication card allowing the unit to be Internet capable, and communicate at a Baud rate of 19.2K or faster

9. Shall have an LED display independently showing the status of activity on the communication bus, and processor operation.

10. Shall have either a field installed BACnet® plug-in communication card which includes an EIA-485 protocol communication port, or a field installed LonWorks™ plug-in communications card.

11. Software upgrades will be accomplished by local download. Software upgrades through chip replacements are not allowed.

12. Shall be shock resistant in all planes to 5G peak, 11ms during operation, and 100G peak, 11ms during storage.

13. Shall be vibration resistant in all planes to 1.5G @ 20-300 Hz.

14. Shall support a bus length of 4000 ft max, 60 devices per 1000 ft section, and 1 RS-485 repeater per 1000 ft sections.

23 09 23.13.B.	Open protocol, direct digital controller:
----------------	---

1. Shall be ASHRAE 62-2001 compliant.

2. Shall accept 18-30VAC, 50-60Hz, and consumer 15VA or less power.

3. Shall have an operating temperature range from -40°F (-40°C) to 130°F (54°C), 10% - 90% RH (non-condensing).

4. Shall have either a field installed BACnet® plug-in communication card which includes an EIA-485 protocol communication port, or a field installed LonWorks™ plug-in communications card.

5. The BACnet® plug in communication card shall include built-in protocol for BACNET (MS/TP and PTP modes)

6. The LonWorks™ plug in communication card shall include the Echelon processor required for all Lon applications.

7. Shall allow access of up to 62 network variables (SNVT). Shall be compatible with all open controllers

8. Baud rate Controller shall be selectable through the EIA-485 protocol communication port.

9. Shall have an LED display independently showing the status of serial communication, running, errors, power, all digital outputs, and all analog inputs.

10. Shall accept the following inputs: space temperature, setpoint adjustment, outdoor air temperature, indoor air quality, outdoor air enthalpy, compressor lock-out, fire shutdown, enthalpy switch, and fan status/filter status/ humidity/ remote occupancy.

11. Shall provide the following outputs: economizer, fan, cooling stage 1, cooling stage 2, heat stage 1, heat stage 2, exhaust.

12. Software upgrades will be accomplished by either local or remote download. No software upgrades through chip replacements are allowed.

23 09 33 Electric and Electronic Control System for HVAC

23 09 33.13 Decentralized, Rooftop Units:

23 09 33.13.A. General:

1. Shall be complete with self-contained low-voltage control circuit protected by a resettable circuit breaker on the 24-v transformer side. Transformer shall have 100VA capabilities.
2. Shall utilize color-coded wiring.
3. Shall include a central control terminal board to conveniently and safely provide connection points for vital control functions such as: smoke detectors, phase monitor, economizer, thermostat, DDC control options, loss of charge, freeze sensor, high pressure switches.
4. Unit shall include a minimum of one 10-pin screw terminal connection board for connection of control wiring.

23 09 33.23.B. Safeties:

1. Compressor over-temperature, over current.
2. Loss of charge switch.
 - a. Units with 2 compressors shall have different colored wires for the circuit 1 and circuit 2 low and high pressure switches.
 - b. Loss of charge switch shall use different color wire than the high pressure switch. The purpose is to assist the installer and service technician to correctly wire and or troubleshoot the rooftop unit.
 - c. Loss of charge switch shall have a different sized connector than the high pressure switch. They shall physically prevent the cross-wiring of the safety switches between the high and low pressure side of the system.
3. High-pressure switch.
 - a. Units with 2 compressors shall have different colored wires for the circuit 1 and circuit 2 low and high pressure switches.
 - b. High pressure switch shall use different color wire than the low pressure switch. The purpose is to assist the installer and service person to correctly wire and or troubleshoot the rooftop unit.
 - c. High pressure switch shall have a different sized connector than the loss of charge switch. They shall physically prevent the cross-wiring of the safety switches between the high and low pressure side of the system.
4. Freeze protection sensor, evaporator coil.
5. Automatic reset, motor thermal overload protector.

23 09 93 Sequence of Operations for HVAC Controls

23 09 93.13 Decentralized, Rooftop Units:

23 09 93.13 INSERT SEQUENCE OF OPERATION

23 40 13 Panel Air Filters

23 40 13.13 Decentralized, Rooftop Units:

23 40 13.13.A. Standard filter section shall

1. Shall consist of factory-installed, low velocity, throwaway 2-in. thick fiberglass filters of commercially available sizes.
2. Filters shall be accessible through an access panel as described in the unit cabinet section of this specification (23 81 19.13.H).

23 81 19 Self-Contained Air Conditioners

23 81 19.13 Small-Capacity Self-Contained Air Conditioners

23 81 19.13.A. General

1. Outdoor, rooftop mounted, electrically controlled, heating and cooling unit utilizing a(n) hermetic scroll compressor(s) for cooling duty and heat pump for heating duty.
2. Factory assembled, single-piece heating and cooling rooftop unit. Contained within the unit enclosure shall be all factory wiring, piping, controls, and special features required prior to field start-up.
3. Unit shall use environmentally sound R-410a refrigerant.
4. Unit shall be installed in accordance with the manufacturer's instructions.
5. Unit must be selected and installed in compliance with local, state, and federal codes.

23 81 19.13.B. Quality Assurance

1. Unit meets ASHRAE 90.1-2004 minimum efficiency requirements.
2. 3 phase units are Energy Star qualified.
3. Unit shall be rated in accordance with AHRI Standards 210/240 and 340/360.
4. Unit shall be designed to conform to ASHRAE 15, 2001.
5. Unit shall be UL-tested and certified in accordance with ANSI Z21.47 Standards and UL-listed and certified under Canadian standards as a total package for safety requirements.
6. Insulation and adhesive shall meet NFPA 90A requirements for flame spread and smoke generation.
7. Unit casing shall be capable of withstanding 500-hour salt spray exposure per ASTM B117 (scribed specimen).
8. Unit casing shall be capable of withstanding Federal Test Method Standard No. 141 (Method 6061) 5000-hour salt spray.
9. Unit shall be designed in accordance with ISO 9001:2000, and shall be manufactured in a facility registered by ISO 9001:2000.
10. Roof curb shall be designed to conform to NRCA Standards.
11. Unit shall be subjected to a completely automated run test on the assembly line. The data for each unit will be stored at the factory, and must be available upon request.
12. Unit shall be designed in accordance with UL Standard 1995, including tested to withstand rain.
13. Unit shall be constructed to prevent intrusion of snow and tested to prevent snow intrusion into the control box up to 40 mph.

23 81 19.13.C. Delivery, Storage, and Handling

1. Unit shall be stored and handled per manufacturer's recommendations.
2. Lifted by crane requires either shipping top panel or spreader bars.
3. Unit shall only be stored or positioned in the upright position.

23 81 19.13.E. Project Conditions

1. As specified in the contract.

23 81 19.13.F. Operating Characteristics

1. Unit shall be capable of starting and running at 115°F (46°C) ambient outdoor temperature, meeting maximum load criteria of AHRI Standard 210/240 or 340/360 at $\pm 10\%$ voltage.
2. Compressor with standard controls shall be capable of operation from 40°F (4°C), ambient outdoor temperatures. Accessory low ambient kit is necessary if mechanically cooling at ambient temperatures below 40°F (4°C).
3. Unit shall discharge supply air vertically or horizontally as shown on contract drawings.
4. Unit shall be factory configured for vertical supply & return configurations.
5. Unit shall be field convertible from vertical to horizontal configuration.

23 81 19.13.G. Electrical Requirements

1. Main power supply voltage, phase, and frequency must match those required by the manufacturer.

23 81 19.13.H. Unit Cabinet

1. Unit cabinet shall be constructed of galvanized steel, and shall be bonderized and coated with a baked enamel finish on all externally exposed surfaces.
2. Unit cabinet exterior paint shall be: film thickness, (dry) 0.003 inches minimum, gloss (per ASTM D523, 60°F): 60, Hardness: H-2H Pencil hardness.
3. Evaporator fan compartment interior cabinet insulation shall conform to AHRI Standards 210/240 or 340/360 minimum exterior sweat criteria. Interior surfaces shall be insulated with a minimum 3/4-in. thick, 1 lb density, flexible fiberglass insulation, aluminum foil-faced on the air side.
4. Base of unit shall have locations for thru-the-base electrical connections (factory installed or field installed), standard.
5. Base Rail
 - a. Unit shall have base rails on all sides.
 - b. Holes shall be provided in the base rails for rigging shackles to facilitate maneuvering and overhead rigging.
 - c. Holes shall be provided in the base rail for moving the rooftop by fork truck.
 - d. Base rail shall be a minimum of 14 gauge thickness.
6. Condensate pan and connections:
 - a. Shall be a sloped condensate drain pan made of a non-corrosive material.
 - b. Shall comply with ASHRAE Standard 62.
 - c. Shall use a 1" -11 1/2 NPT drain connection, through the side of the drain pan. Connection shall be made per manufacturer's recommendations.
7. Electrical Connections
 - a. All unit power wiring shall enter unit cabinet at a single, factory-prepared, knockout location.
 - b. Thru-the-base capability
 - (1.) Standard unit shall have a thru-the-base electrical location(s) using a raised, embossed portion of the unit basepan.
 - (2.) No basepan penetration, other than those authorized by the manufacturer, is permitted.
8. Component access panels (standard)
 - a. Cabinet panels shall be easily removable for servicing.
 - b. Stainless steel metal hinges are standard on all doors.
 - c. Panels covering control box, indoor fan, indoor fan motor, and electric or gas heater components (where applicable), shall have 1/4 turn latches.

23 81 19.13.J. Coils

1. Standard Aluminum/Copper Coils: on all models.
 - a. Standard evaporator and condenser coils shall have aluminum lanced plate fins mechanically bonded to seamless internally grooved copper tubes with all joints brazed.
 - b. Evaporator and Condenser coils shall be leak tested to 150 psig, pressure tested to 550 psig, and qualified to UL 1995 burst test at 2,200 psig.

23 81 19.13.K. Refrigerant Components

1. Refrigerant circuit shall include the following control, safety, and maintenance features:
 - a. Thermal Expansion Valve (TXV) with orifice type distributor
 - b. Refrigerant filter drier.
 - c. External service gauge connections to unit suction and discharge lines.
 - d. Pressure gauge access through an access port in the front and rear panel of the unit.
2. Compressors
 - a. Unit shall use one fully hermetic, scroll compressor for each independent refrigeration circuit.
 - b. Compressor motors shall be cooled by refrigerant gas passing through motor windings.
 - d. Compressors shall be internally protected from high discharge temperature conditions. Advanced Scroll Temperature Protection on 240-300 sizes.

- e. Compressors shall be protected from an over-temperature and over-ampereage conditions by an internal, motor overload device.
- f. Compressor shall be factory mounted on rubber grommets.
- g. Compressor motors shall have internal line break thermal, current overload and high pressure differential protection.
- h. Crankcase heaters shall not be required for normal operating range.

23 81 19.13.L. Filter Section

- 1. Filters access is specified in the unit cabinet section of this specification.
- 2. Filters shall be held in place by a sliding filter tray, facilitating easy removal and installation.
- 3. Shall consist of factory-installed, low velocity, throw-away 2-in. thick fiberglass filters.
- 4. Filters shall be standard, commercially available sizes.
- 5. Filter face velocity shall not exceed 365 fpm at nominal airflows.

23 81 19.13.M. Evaporator Fan and Motor

- 1. Evaporator fan motor:
 - a. Shall have permanently lubricated bearings.
 - b. Shall have inherent automatic-reset thermal overload protection or circuit breaker.
 - c. Shall have a maximum continuous bhp rating for continuous duty operation; no safety factors above that rating shall be required.
- 2. Belt-driven Evaporator Fan:
 - a. Belt drive shall include an adjustable-pitch motor pulley.
 - b. Shall use sealed, permanently lubricated ball-bearing type.
 - c. Blower fan shall be double-inlet type with forward-curved blades.
 - d. Shall be constructed from steel with a corrosion resistant finish and dynamically balanced.

23 81 19.13.N. Condenser Fans and Motors

- 1. Condenser fan motors:
 - a. Shall be a totally enclosed motor.
 - b. Shall use permanently lubricated bearings.
 - c. Shall have inherent thermal overload protection with an automatic reset feature.
 - d. Shall use a shaft-down design. Shaft-up designs including those with "rain-slinger devices" shall not be allowed.
- 2. Condenser Fans:
 - a. Shall be a direct-driven propeller type fan.
 - b. Shall have aluminum blades riveted to corrosion-resistant steel spiders and shall be dynamically balanced.

23 81 19.13.O. Special Features, Options and Accessories

- 1. Integrated Economizers:
 - a. Integrated, gear-driven parallel modulating blade design type capable of simultaneous economizer and compressor operation.
 - b. Independent modules for vertical or horizontal return configurations shall be available. Vertical return modules shall be available as a factory installed option.
 - c. Damper blades shall be galvanized steel with metal gears. Plastic or composite blades on intake or return shall not be acceptable.
 - d. Shall include all hardware and controls to provide free cooling with outdoor air when temperature and/or humidity are below setpoints.
 - e. Shall be equipped with gear driven dampers for both the outdoor ventilation air and the return air for positive air stream control.
 - f. Shall be capable of introducing up to 100% outdoor air.
 - g. Shall be equipped with a barometric relief damper capable of relieving up to 100% return air.
 - h. Shall be designed to close damper(s) during loss-of-power situations with spring return built into motor.
 - i. An outdoor single enthalpy sensor shall be provided as standard. Outdoor air sensor setpoint shall be adjustable and shall range from the enthalpy equivalent of 63°F @ 50% rh to 73°F @ 50% rh. Additional sensor options shall be available as accessories.
 - j. The economizer controller shall also provide control of an accessory power exhaust unit function. Factory set at 70%, with a range of 0% to 100%.
 - k. The economizer shall maintain minimum airflow into the building during occupied period and provide design ventilation rate for full occupancy. A remote potentiometer may be used to override the damper setpoint.
 - l. Dampers shall be completely closed when the unit is in the unoccupied mode.
 - m. Economizer controller shall accept a 2-10Vdc CO₂ sensor input for IAQ/DCV control. In this mode, dampers shall modulate the outdoor-air damper to provide ventilation based on the sensor input.
 - n. Compressor lockout sensor on the unit controller is factory set at 35°F and is adjustable from 30°F (-1°C) to 50°F (10°C) and resets the cooling lockout at 5°F (+2.7°C) above the set point.
 - o. Actuator shall be direct coupled to economizer gear. No linkage arms or control rods shall be acceptable.
 - p. Economizer controller shall provide indications when in free cooling mode, in the DCV mode, or the exhaust fan contact is closed.
 - q. Economizer wire harness will have provision for smoke detector.

2. Two-Position Motorized Damper
 - a. Damper shall be a Two-Position Motorized Damper. Damper travel shall be from the full closed position to the field adjustable %-open setpoint.
 - b. Damper shall include adjustable damper travel from 25% to 100% (full open).
 - c. Damper shall include single or dual blade, gear driven dampers and actuator motor.
 - d. Actuator shall be direct coupled to damper gear. No linkage arms or control rods shall be acceptable.
 - e. Damper will admit up to 100% outdoor air for applicable rooftop units.
 - f. Damper shall close upon indoor (evaporator) fan shutoff and/or loss of power.
 - g. The damper actuator shall plug into the rooftop unit's wiring harness plug. No hard wiring shall be required.
 - h. Outside air hood shall include aluminum water entrainment filter
3. Manual damper
 - a. Manual damper package shall consist of damper, air inlet screen, and rain hood which can be preset to admit up to 50% outdoor air for year round ventilation.
4. Head Pressure Control Package
 - a. Controller shall control coil head pressure by condenser-fan cycling.
5. Condenser Coil Hail Guard Assembly
 - a. Shall protect against damage from hail.
 - b. Shall be louvered design.
6. Convenience Outlet:
 - a. Non-Powered convenience outlet.
 - (1.) Outlet shall be powered from a separate 115-120v power source.
 - (2.) A transformer shall not be included.
 - (3.) Outlet shall be factory-installed and internally mounted with easily accessible 115-v female receptacle.
 - (4.) Outlet shall include 15 amp GFI receptacles.
 - (5.) Outlet shall be accessible from outside the unit.
7. Fan/Filter Status Switch:
 - a. Switch shall provide status of indoor evaporator fan (ON/OFF) or filter (CLEAN/DIRTY).
 - b. Status shall be displayed either over communication bus (when used with direct digital controls) or through the controller LCD display inside the unit control box.
8. Propeller Power Exhaust:
 - a. Power exhaust shall be used in conjunction with an integrated economizer.
 - b. Independent modules for vertical or horizontal return configurations shall be available.
 - c. Horizontal power exhaust is shall be mounted in return ductwork.
 - d. Power exhaust shall be controlled by economizer controller operation. Exhaust fans shall be energized when dampers open past the 0-100% adjustable setpoint on the economizer control.
9. Roof Curbs (Vertical):
 - a. Full perimeter roof curb with exhaust capability providing separate air streams for energy recovery from the exhaust air without supply air contamination.
 - b. Formed galvanized steel with wood nailer strip and shall be capable of supporting entire unit weight.
 - c. Permits installation and securing of ductwork to curb prior to mounting unit on the curb.
10. High-Static Indoor Fan Motor(s) and Drive(s):
 - a. High-static motor(s) and drive(s) shall be factory-installed to provide additional performance range.
11. Outdoor Air Enthalpy Sensor:
 - a. The outdoor air enthalpy sensor shall be used to provide single enthalpy control. When used in conjunction with a return air enthalpy sensor, the unit will provide differential enthalpy control. The sensor allows the unit to determine if outside air is suitable for free cooling.
13. Return Air Enthalpy Sensor:
 - a. The return air enthalpy sensor shall be used in conjunction with an outdoor air enthalpy sensor to provide differential enthalpy control.
14. Indoor Air Quality (CO₂) Sensor:
 - a. Shall be able to provide demand ventilation indoor air quality (IAQ) control.
 - b. The IAQ sensor shall be available in wall mount with LED display. The setpoint shall have adjustment capability.
15. Smoke detectors:
 - a. Shall be a Four-Wire Controller and Detector.
 - b. Shall be environmental compensated with differential sensing for reliable, stable, and drift-free sensitivity.
 - c. Shall use magnet-activated test/reset sensor switches.
 - d. Shall have a recessed momentary switch for testing and resetting the detector.
 - e. Controller shall include:

- (1.) One set of normally open alarm initiation contacts for connection to an initiating device circuit on a fire alarm control panel.
 - (2.) Two Form-C auxiliary alarm relays for interface with rooftop unit or other equipment.
 - (3.) One Form-C supervision (trouble) relay to control the operation of the Trouble LED on a remote test/reset station.
 - (4.) Capable of direct connection to two individual detector modules.
 - (5.) Can be wired to up to 14 other duct smoke detectors for multiple fan shutdown applications.
16. Electric Heat:
- a. Heating Section
 - (1.) Heater element open coil resistance wire, nickel-chrome alloy, strung through ceramic insulators mounted on metal frame. Coil ends are staked and welded to terminal screw slots.
 - (2.) Heater assemblies are provided with integral fusing for protection of internal heater circuits not exceeding 48 amps each. Auto reset thermo limit controls, magnetic heater contactors (24 v coil) and terminal block all mounted in electric heater control box (minimum 18 ga galvanized steel) attached to end of heater assembly.

26 29 23.12 Adjustable Frequency Drive

1. Unit shall be supplied with an electronic variable frequency drive for the supply air fan.
2. Drive shall be factory installed in an enclosed cabinet.
3. Drive shall meet UL Standard 95-5V.
4. The completed unit assembly shall be UL listed.
5. Drives are to be accessible through a tooled access hinged door assembly.
6. The unit manufacturer shall install all power and control wiring.
7. The supply air fan drive output shall be controlled by the factory installed main unit control system and drive status and operating speed shall be monitored and displayed at the main unit control panel.
8. Drive shall be programmed and factory run tested in the unit.

BEFORE PURCHASING THIS APPLIANCE, READ IMPORTANT ENERGY COST AND EFFICIENCY INFORMATION AVAILABLE FROM YOUR RETAILER.

GENERAL TERMS OF LIMITED WARRANTY*

Rheem will furnish a replacement for any part of this product which fails in normal use and service within the applicable periods stated, in accordance with the terms of the limited warranty.

***For complete details of the Limited and Conditional Warranties, including applicable terms and conditions, contact your local contractor or the Manufacturer for a copy of the product warranty certificate.**

Compressor	
3 Phase, Commercial Applications	Five (5) Years
Parts	
3 Phase, Commercial Applications.....	One (1) Year



The new degree of comfort.™

In keeping with its policy of continuous progress and product improvement, Rheem reserves the right to make changes without notice.

Rheem Heating, Cooling & Water Heating • P.O. Box 17010
Fort Smith, Arkansas 72917 • www.rheem.com

Rheem Canada Ltd./Ltée • 125 Edgeware Road, Unit 1
Brampton, Ontario • L6Y 0P5



INTEGRATED AIR & WATER