

INSTALLATION INSTRUCTIONS

FOR PACKAGE AIR CONDITIONERS

RLNL-B/RLNL-C/RLNL-H SERIES 15, 17.5, 20 & 25 TON
[52.8, 61.5, 70.3, 87.9 kW]

RLNL-B: ASHRAE 90.1 2007 COMPLIANT

RLNL-C: ASHRAE 90.1 2007 COMPLIANT, WITH CLEAR CONTROL

RLNL-H: ASHRAE 90.1 2010 COMPLIANT, WITH CLEAR CONTROL AND VFD



RECOGNIZE THIS SYMBOL AS AN INDICATION OF IMPORTANT SAFETY INFORMATION!

WARNING

THESE INSTRUCTIONS ARE INTENDED AS AN AID TO QUALIFIED, LICENSED SERVICE PERSONNEL FOR PROPER INSTALLATION, ADJUSTMENT AND OPERATION OF THIS UNIT. READ THESE INSTRUCTIONS THOROUGHLY BEFORE ATTEMPTING INSTALLATION OR OPERATION. FAILURE TO FOLLOW THESE INSTRUCTIONS MAY RESULT IN IMPROPER INSTALLATION, ADJUSTMENT, SERVICE OR MAINTENANCE POSSIBLY RESULTING IN FIRE, ELECTRICAL SHOCK, PROPERTY DAMAGE, PERSONAL INJURY OR DEATH.



25 TON IS OUTSIDE THE SCOPE OF ARI STANDARD 340/360



Accredited by the RVA



ISO 9001:2008

Certificate Number: 30164

DO NOT DESTROY THIS MANUAL

PLEASE READ CAREFULLY AND KEEP IN A SAFE PLACE FOR FUTURE REFERENCE BY A SERVICEMAN



[] INDICATES METRIC CONVERSIONS

92-23577-86-04
SUPERSEDES 92-23577-86-03

I. TABLE OF CONTENTS

Table of Contents	2
Introduction	3
Checking Product Received.	3
Equipment Protection.	3
Specifications.	3
General	3
Major Components.	4
R-410A Refrigerant	4
Unit Dimensions	5-7
General Data	8-14
Electrical Data.	15-17
Installation	18
General	18
Pre-Installation Check Points.	18
Location	18
Outside Slab Installation	18
Clearances.	18
Rooftop Installation	19
Ductwork	20
Filters	20
Cover Panel Installation/Conversion Procedure	21
Condensate Drain	21
Electrical Wiring	21
Power Wiring	22
Control Wiring	22
Internal Wiring	22
Thermostat.	22
Indoor Air Flow Data	23
Crankcase Heat	23
Airflow Performance Tables	24-27
Pre-Start Check	28
Startup	28
Operation	28
Cooling Mode.	28
Heating Mode.	28
Units With A Blower VFD	29
Auxiliary Heat.	29
Heater Kit Characteristics.	30-35
Troubleshooting Chart	36
Wiring Diagrams	37-42
Charge Charts	43-46

▲ WARNING

PROPOSITION 65: THIS APPLIANCE CONTAINS FIBERGLASS INSULATION. RESPIRABLE PARTICLES OF FIBERGLASS ARE KNOWN TO THE STATE OF CALIFORNIA TO CAUSE CANCER.

▲ WARNING

THE MANUFACTURER'S WARRANTY DOES NOT COVER ANY DAMAGE OR DEFECT TO THE AIR CONDITIONER CAUSED BY THE ATTACHMENT OR USE OF ANY COMPONENTS, ACCESSORIES OR DEVICES (OTHER THAN THOSE AUTHORIZED BY THE MANUFACTURER) INTO, ONTO OR IN CONJUNCTION WITH THE AIR CONDITIONER. YOU SHOULD BE AWARE THAT THE USE OF UNAUTHORIZED COMPONENTS, ACCESSORIES OR DEVICES MAY ADVERSELY AFFECT THE OPERATION OF THE AIR CONDITIONER AND MAY ALSO ENDANGER LIFE AND PROPERTY. THE MANUFACTURER DISCLAIMS ANY RESPONSIBILITY FOR SUCH LOSS OR INJURY RESULTING FROM THE USE OF SUCH UNAUTHORIZED COMPONENTS, ACCESSORIES OR DEVICES.

▲ WARNING

DISCONNECT ALL POWER TO THE UNIT BEFORE STARTING MAINTENANCE. FAILURE TO DO SO CAN RESULT IN SEVERE ELECTRICAL SHOCK OR DEATH.

II. INTRODUCTION

This booklet contains the installation and operating instructions for your air conditioner. There are a few precautions that should be taken to derive maximum satisfaction from it. Improper installation can result in unsatisfactory operation or dangerous conditions.

Read this booklet and any instructions packaged with separate equipment required to make up the system prior to installation. Give this booklet to the owner and explain its provisions. The owner should retain this booklet for future reference.

III. CHECKING PRODUCT RECEIVED

Upon receiving the unit, inspect it for any damage from shipment. Claims for damage, either shipping or concealed, should be filed immediately with the shipping company. Check the unit model number, heating size, electrical characteristics, and accessories to determine if they are correct.

IV. EQUIPMENT PROTECTION FROM THE ENVIRONMENT

The metal parts of this unit may be subject to rust or deterioration in adverse environmental conditions. This oxidation could shorten the equipment's useful life. Salt spray, fog or mist in seacoast areas, sulphur or chlorine from lawn watering systems, and various chemical contaminants from industries such as paper mills and petroleum refineries are especially corrosive.

If the unit is to be installed in an area where contaminants are likely to be a problem, special attention should be given to the equipment location and exposure.

1. Avoid having lawn sprinkler heads spray direction on the unit cabinet.
2. In coastal areas, locate the unit on the side of the building away from the waterfront.
3. Shielding provided by a fence or shrubs may give some protection.

Regular maintenance will reduce the buildup of contaminants and help to protect the unit's finish.

1. Frequent washing of the cabinet, fan blade and coil with fresh water will remove most of the salt or other contaminants that build up on the unit.
2. Regular cleaning and waxing of the cabinet with a good automobile polish will provide some protection.
3. A good liquid cleaner may be used several times a year to remove matter that will not wash off with water.

Several different types of protective coatings are offered in some areas. These coatings may provide some benefit, but the effectiveness of such coating materials cannot be verified by the equipment manufacturer.

The best protection is frequent cleaning, maintenance and minimal exposure to contaminants.

V. SPECIFICATIONS

A. GENERAL

The Packaged Air Conditioner is available without heat or with 20, 40, 60 or 75 kW electric heat. Cooling capacities of 15, 17.5, 20, and 25 nominal tons of cooling are available. Units are convertible from bottom supply and return to horizontal supply and return by relocation of supply and return air access panels. See cover installation detail.

The units are weatherized for mounting outside of the building.

The information on the rating plate is in compliance with the FTC and DOE rating for single phase units. The following information is for three phase units which **are not** covered under the DOE certification program.

1. The efficiency rating of this unit is a product thermal efficiency rating determined under continuous operating conditions independent of any installed system.

B. MAJOR COMPONENTS

The unit includes a hermetically-sealed refrigerating system (consisting of compressors, condenser coil, evaporator coil with thermal expansion valves), a circulation air blower, condenser fans, and all necessary internal electrical wiring. The cooling system of these units is factory-evacuated, charged and performance tested. Refrigerant amount and type are indicated on rating plate.

C. R-410A REFRIGERANT

All units are factory charged with R-410A refrigerant.

1. Specification of R-410A:

Application: **R-410A is not a drop-in replacement for R-22;** equipment designs must accommodate its higher pressures. It cannot be retrofitted into R-22 units.

Pressure: **The pressure of R-410A is approximately 60% (1.6 times) greater than R-22.** Recovery and recycle equipment, pumps, hoses and the like need to have design pressure ratings appropriate for R-410A. *Manifold sets need to range up to 800 psig high-side and 250 psig low-side with a 550 psig low-side retard. Hoses need to have a service pressure rating of 800 psig. Recovery cylinders need to have a 400 psig service pressure rating. DOT 4BA400 or DOT BW400.*

Combustibility: At pressures above 1 atmosphere, mixture of R-410A and air can become combustible. **R-410A and air should never be mixed in tanks or supply lines, or be allowed to accumulate in storage tanks. Leak checking should never be done with a mixture of R-410A and air.** Leak checking can be performed safely with nitrogen or a mixture of R-410A and nitrogen.

2. Quick Reference Guide For R-410A

- R-410A refrigerant operates at approximately 60% higher pressure (1.6 times) than R-22. Ensure that servicing equipment is designed to operate with R-410A.
- R-410A refrigerant cylinders are pink.
- R-410A, as with other HFC's is only compatible with POE oils.
- Vacuum pumps will not remove moisture from POE oil.
- R-410A systems are to be charged with liquid refrigerants. Prior to March 1999, R-410A refrigerant cylinders had a dip tube. These cylinders should be kept upright for equipment charging. Post March 1999 cylinders do not have a dip tube and should be inverted to ensure liquid charging of the equipment.
- Do not install a suction line filter drier in the liquid line.
- A liquid line filter drier is standard on every unit.
- Desiccant (drying agent) must be compatible for POE oils and R-410A.

3. Evaporator Coil / TXV

The thermostatic expansion valve is specifically designed to operate with R-410A. **DO NOT use an R-22 TXV. The existing evaporator must be replaced with the factory specified TXV evaporator specifically designed for R-410A.**

4. Tools Required For Installing & Servicing R-410A Models

Manifold Sets:

- Up to 800 PSIG High side
- Up to 250 PSIG Low Side
- 550 PSIG Low Side Retard

Manifold Hoses:

- Service Pressure Rating of 800 PSIG

Recovery Cylinders:

- 400 PSIG Pressure Rating
- Dept. of Transportation 4BA400 or BW400

CAUTION

R-410A systems operate at higher pressures than R-22 systems. Do not use R-22 service equipment or components on R-410A equipment.

FIGURE 1
UNIT DIMENSIONS (BOTTOM VIEW)

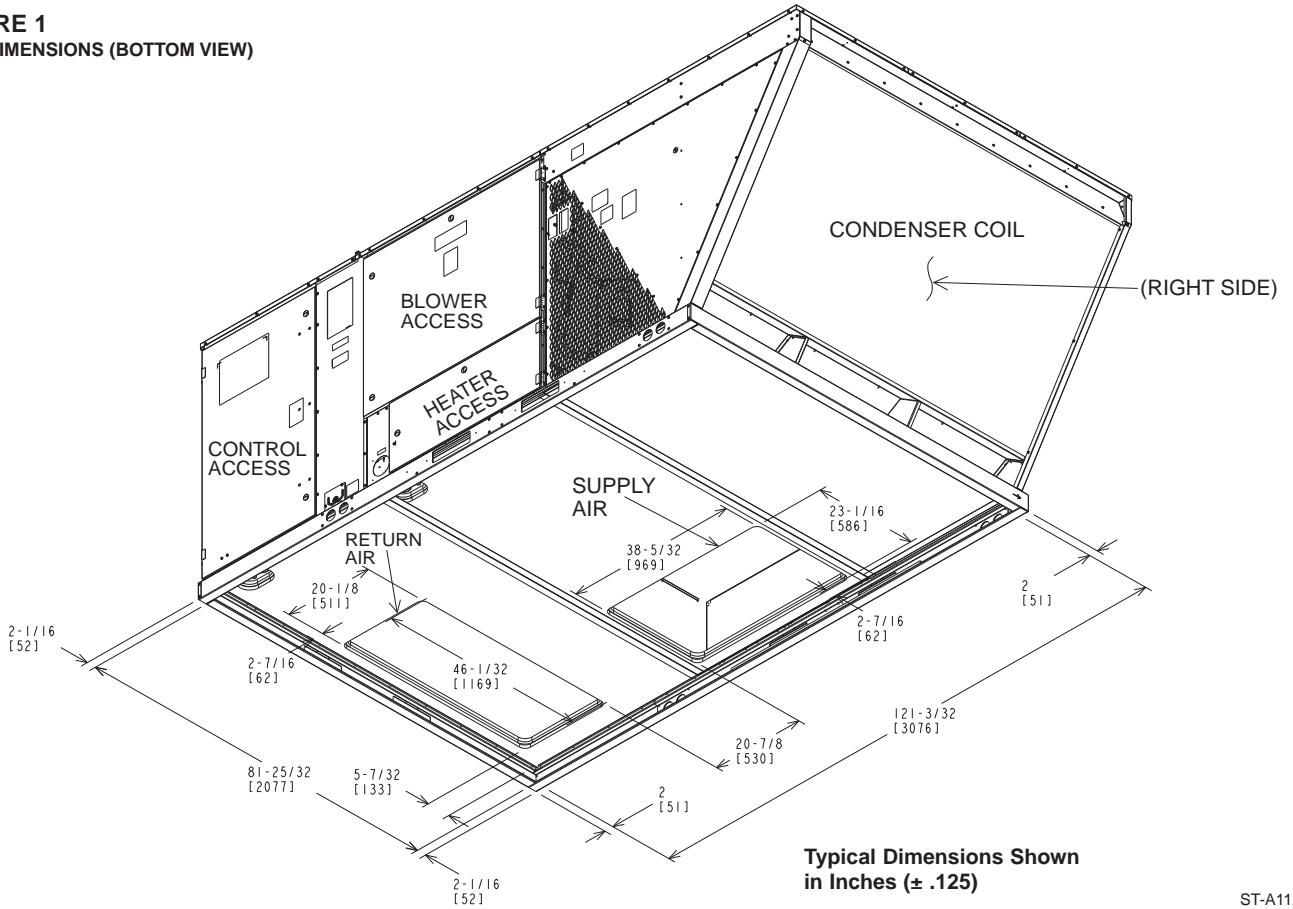

ST-A1125-02B

FIGURE 2
UNIT DIMENSIONS (BOTTOM VIEW)

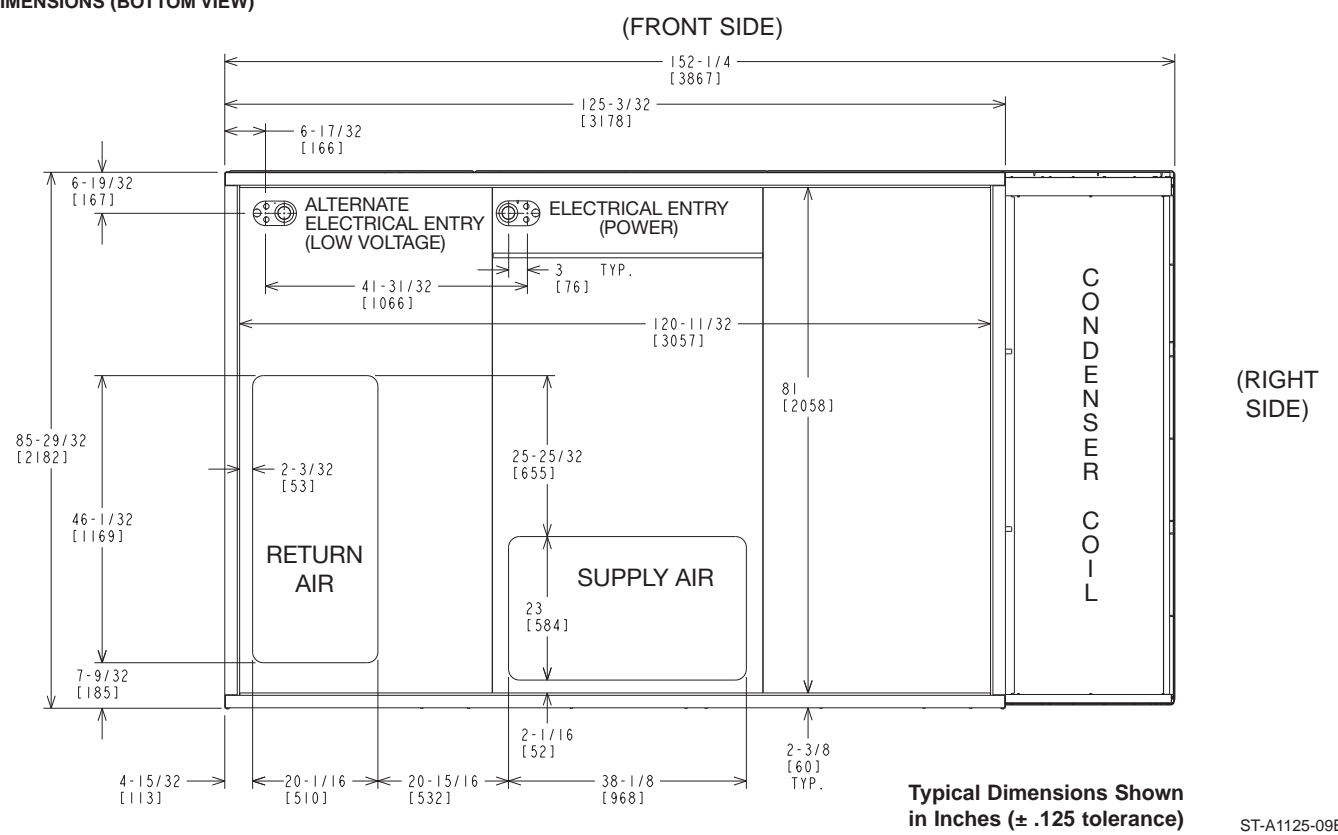

ST-A1125-09B

**FIGURE 3
UNIT DIMENSIONS**

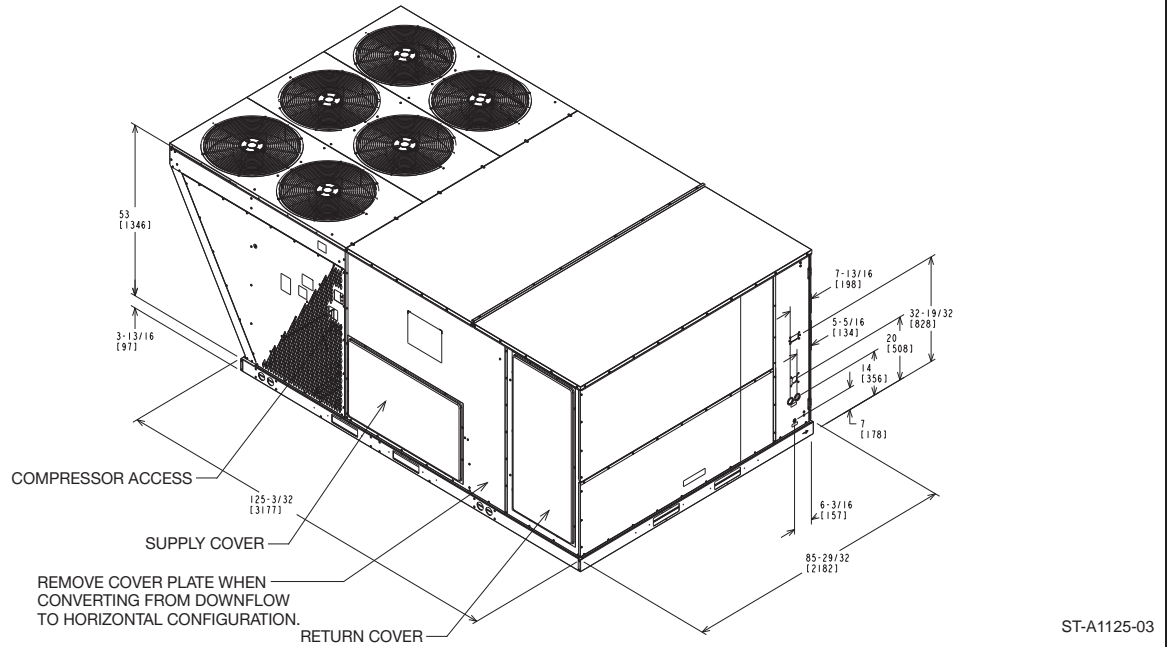

**FIGURE 4
UNIT DIMENSIONS**

REAR VIEW

CONDENSER COIL (RIGHT SIDE)

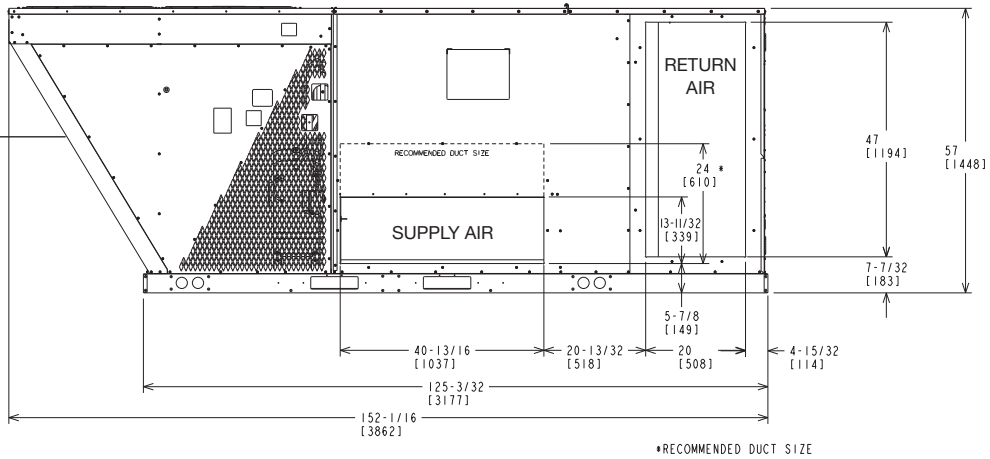

**FIGURE 5
COMPONENT LOCATION**

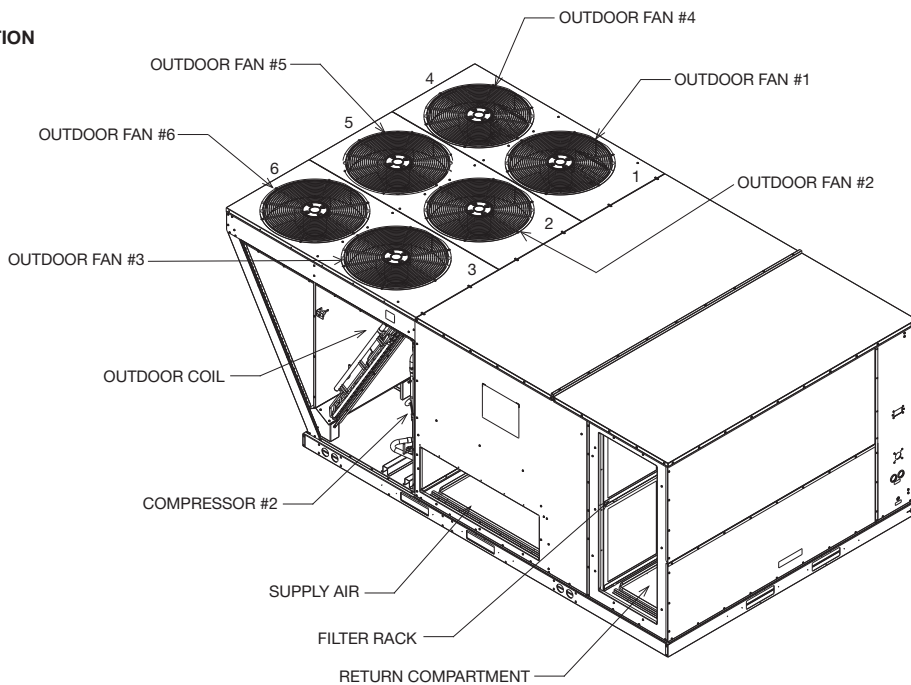

FIGURE 6
UNIT DIMENSIONS & COMPONENT ACCESS

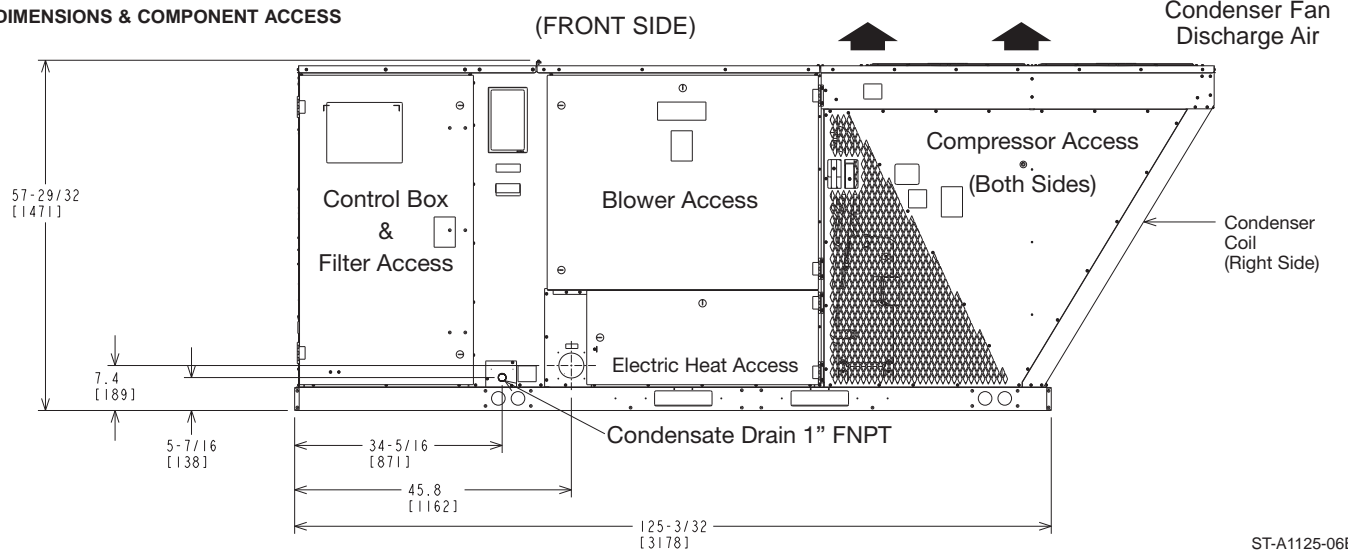

FIGURE 7
UNIT DIMENSIONS & COMPONENT ACCESS

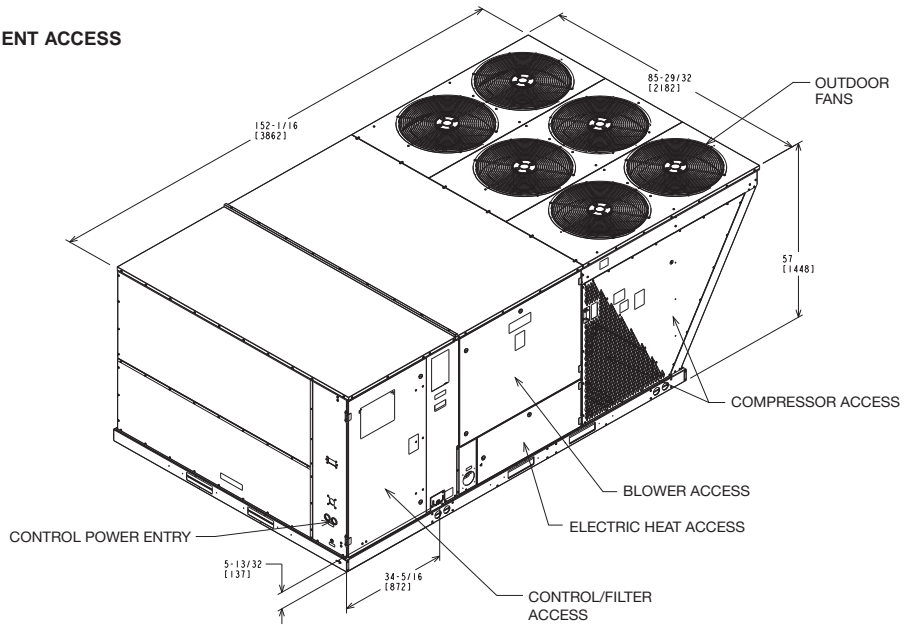
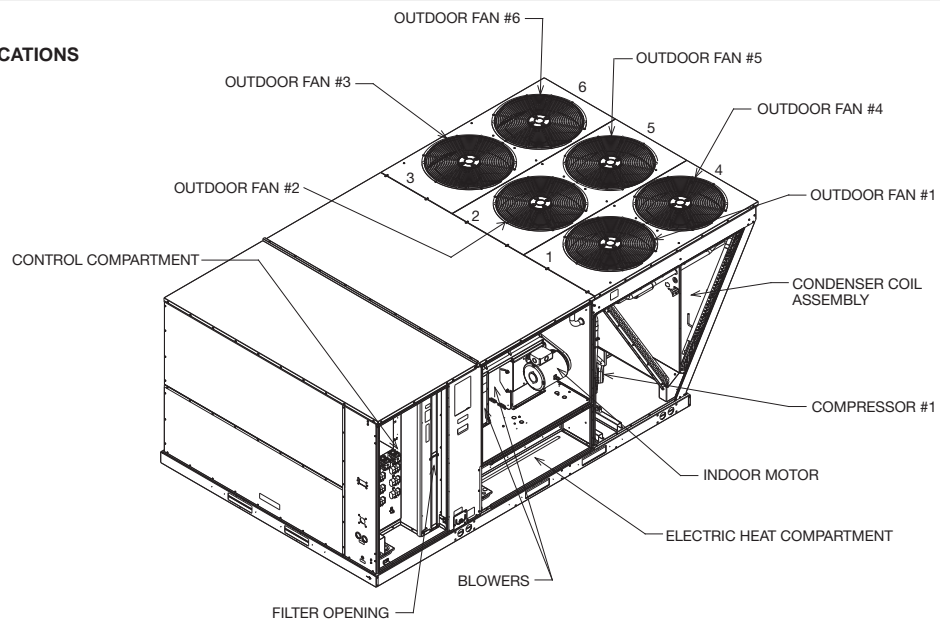

FIGURE 8
INTERNAL COMPONENT LOCATIONS



GENERAL DATA - RLNL

Model RLNL- Series Model RKNL- Series (with VFD)	(B,C)180CL H180CR	(B,C)180CM H180CS	(B,C)180DL H180DR	(B,C)180DM H180DS
Cooling Performance¹				Continued ->
Gross Cooling Capacity Btu [kW]	188,000 [55.08]	188,000 [55.08]	188,000 [55.08]	188,000 [55.08]
EER, SEER ²	11.1/NA	11.1/NA	11.1/NA	11.1/NA
Nominal CFM/AHRI Rated CFM [L/s]	6000/5900 [2831/2784]	6000/5900 [2831/2784]	6000/5900 [2831/2784]	6000/5900 [2831/2784]
AHRI Net Cooling Capacity Btu [kW]	182,000 [53.33]	182,000 [53.33]	182,000 [53.33]	182,000 [53.33]
Net Sensible Capacity Btu [kW]	135,700 [39.76]	135,700 [39.76]	135,700 [39.76]	135,700 [39.76]
Net Latent Capacity Btu [kW]	46,300 [13.57]	46,300 [13.57]	46,300 [13.57]	46,300 [13.57]
IEER ³ (Standard / VFD)	12.4/14.6	12.4/14.6	12.4/14.6	12.4/14.6
Net System Power kW	16.35	16.35	16.35	16.35
Compressor				
No./Type	2/Scroll	2/Scroll	2/Scroll	2/Scroll
Outdoor Sound Rating (dB)⁵	91	91	91	91
Outdoor Coil - Fin Type	Louvered	Louvered	Louvered	Louvered
Tube Type	Rifled	Rifled	Rifled	Rifled
Tube Size in. [mm] OD	0.375 [9.5]	0.375 [9.5]	0.375 [9.5]	0.375 [9.5]
Face Area sq. ft. [sq. m]	53.3 [4.95]	53.3 [4.95]	53.3 [4.95]	53.3 [4.95]
Rows / FPI [FPcm]	1 / 22 [9]	1 / 22 [9]	1 / 22 [9]	1 / 22 [9]
Indoor Coil - Fin Type	Louvered	Louvered	Louvered	Louvered
Tube Type	Rifled	Rifled	Rifled	Rifled
Tube Size in. [mm]	0.375 [9.5]	0.375 [9.5]	0.375 [9.5]	0.375 [9.5]
Face Area sq. ft. [sq. m]	26.67 [2.48]	26.67 [2.48]	26.67 [2.48]	26.67 [2.48]
Rows / FPI [FPcm]	2 / 18 [7]	2 / 18 [7]	2 / 18 [7]	2 / 18 [7]
Refrigerant Control	TX Valves	TX Valves	TX Valves	TX Valves
Drain Connection No./Size in. [mm]	1/1 [25.4]	1/1 [25.4]	1/1 [25.4]	1/1 [25.4]
Outdoor Fan - Type	Propeller	Propeller	Propeller	Propeller
No. Used/Diameter in. [mm]	4/24 [609.6]	4/24 [609.6]	4/24 [609.6]	4/24 [609.6]
Drive Type/No. Speeds	Direct/1	Direct/1	Direct/1	Direct/1
CFM [L/s]	16000 [7550]	16000 [7550]	16000 [7550]	16000 [7550]
No. Motors/HP	4 at 1/3 HP	4 at 1/3 HP	4 at 1/3 HP	4 at 1/3 HP
Motor RPM	1075	1075	1075	1075
Indoor Fan - Type	FC Centrifugal	FC Centrifugal	FC Centrifugal	FC Centrifugal
No. Used/Diameter in. [mm]	2/18x9 [457x229]	2/18x9 [457x229]	2/18x9 [457x229]	2/18x9 [457x229]
Drive Type	Belt (Adjustable)	Belt (Adjustable)	Belt (Adjustable)	Belt (Adjustable)
No. Speeds (Standard / VFD)	Single / Multiple	Single / Multiple	Single / Multiple	Single / Multiple
No. Motors	1	1	1	1
Motor HP	3	5	3	5
Motor RPM	1725	1725	1725	1725
Motor Frame Size	56	184	56	184
Filter - Type	Disposable	Disposable	Disposable	Disposable
Furnished	Yes	Yes	Yes	Yes
(NO.) Size Recommended in. [mm x mm x mm]	(8)2x25x20 [51x635x508]	(8)2x25x20 [51x635x508]	(8)2x25x20 [51x635x508]	(8)2x25x20 [51x635x508]
Refrigerant Charge Oz. (Sys. 1/Sys. 2) [g]	205/211 [5812/5982]	205/211 [5812/5982]	205/211 [5812/5982]	205/211 [5812/5982]
Weights				
Net Weight lbs. [kg]	1826 [828]	1855 [841]	1826 [828]	1855 [841]
Ship Weight lbs. [kg]	1952 [885]	1981 [899]	1952 [885]	1981 [899]

NOTES:

- Cooling Performance is rated at 95° F ambient, 80° F entering dry bulb, 67° F entering wet bulb. Gross capacity does not include the effect of fan motor heat. AHRI capacity is net and includes the effect of fan motor heat. Units are suitable for operation to ±20% of nominal cfm. Units are certified in accordance with the Unitary Air Conditioner Equipment certification program, which is based on AHRI Standard 210/240 or 360.
- EER and/or SEER are rated at AHRI conditions and in accordance with DOE test procedures.
- Integrated Energy Efficiency Ratio (IEER) is rated in accordance with AHRI Standard 210/240 or 340/360.
- Not applicable to these units.
- Outdoor Sound Rating shown is tested in accordance with ARI Standard 270. 25 Ton Model is outside the scope of AHRI Standard 340/360.

GENERAL DATA - RLNL

Model RLNL- Series Model RKNL- Series (with VFD)	(B,C)180YL	(B,C)180YM	(B,C)210CL H210CR	(B,C)210CM H210CS
Cooling Performance¹				Continued ->
Gross Cooling Capacity Btu [kW]	188,000 [55.08]	188,000 [55.08]	212,000 [62.12]	212,000 [62.12]
EER, SEER ²	11.1/NA	11.1/NA	11.6/NA	11.6/NA
Nominal CFM/ARI Rated CFM [L/s]	6000/5900 [2831/2784]	6000/5900 [2831/2784]	7000/7025 [3303/3315]	7000/7025 [3303/3315]
ARI Net Cooling Capacity Btu [kW]	182,000 [53.33]	182,000 [53.33]	204,000 [59.77]	204,000 [59.77]
Net Sensible Capacity Btu [kW]	135,700 [39.76]	135,700 [39.76]	154,900 [45.39]	154,900 [45.39]
Net Latent Capacity Btu [kW]	46,300 [13.57]	46,300 [13.57]	49,100 [14.39]	49,100 [14.39]
IEER ³ (Standard / VFD)	12.4	12.4	12.6/14.5	12.6/14.5
Net System Power kW	16.35	16.35	17.57	17.57
Compressor				
No./Type	2/Scroll	2/Scroll	2/Scroll	2/Scroll
Outdoor Sound Rating (dB)⁵	91	91	91	91
Outdoor Coil - Fin Type	Louvered	Louvered	Louvered	Louvered
Tube Type	Rifled	Rifled	Rifled	Rifled
Tube Size in. [mm] OD	0.375 [9.5]	0.375 [9.5]	0.375 [9.5]	0.375 [9.5]
Face Area sq. ft. [sq. m]	53.3 [4.95]	53.3 [4.95]	53.3 [4.95]	53.3 [4.95]
Rows / FPI [FPcm]	1 / 22 [9]	1 / 22 [9]	2 / 18 [7]	2 / 18 [7]
Indoor Coil - Fin Type	Louvered	Louvered	Louvered	Louvered
Tube Type	Rifled	Rifled	Rifled	Rifled
Tube Size in. [mm]	0.375 [9.5]	0.375 [9.5]	0.375 [9.5]	0.375 [9.5]
Face Area sq. ft. [sq. m]	26.67 [2.48]	26.67 [2.48]	26.67 [2.48]	26.67 [2.48]
Rows / FPI [FPcm]	2 / 18 [7]	2 / 18 [7]	2 / 18 [7]	2 / 18 [7]
Refrigerant Control	TX Valves	TX Valves	TX Valves	TX Valves
Drain Connection No./Size in. [mm]	1/1 [25.4]	1/1 [25.4]	1/1 [25.4]	1/1 [25.4]
Outdoor Fan - Type	Propeller	Propeller	Propeller	Propeller
No. Used/Diameter in. [mm]	4/24 [609.6]	4/24 [609.6]	4/24 [609.6]	4/24 [609.6]
Drive Type/No. Speeds	Direct/1	Direct/1	Direct/1	Direct/1
CFM [L/s]	16000 [7550]	16000 [7550]	14800 [6984]	14800 [6984]
No. Motors/HP	4 at 1/3 HP	4 at 1/3 HP	4 at 1/3 HP	4 at 1/3 HP
Motor RPM	1075	1075	1075	1075
Indoor Fan - Type	FC Centrifugal	FC Centrifugal	FC Centrifugal	FC Centrifugal
No. Used/Diameter in. [mm]	2/18x9 [457x229]	2/18x9 [457x229]	2/18x9 [457x229]	2/18x9 [457x229]
Drive Type	Belt (Adjustable)	Belt (Adjustable)	Belt (Adjustable)	Belt (Adjustable)
No. Speeds (Standard / VFD)	Single	Single	Single / Multiple	Single / Multiple
No. Motors	1	1	1	1
Motor HP	3	5	3	5
Motor RPM	1725	1725	1725	1725
Motor Frame Size	56	184	56	184
Filter - Type	Disposable	Disposable	Disposable	Disposable
Furnished	Yes	Yes	Yes	Yes
(NO.) Size Recommended in. [mm x mm x mm]	(8)2x25x20 [51x635x508]	(8)2x25x20 [51x635x508]	(8)2x25x20 [51x635x508]	(8)2x25x20 [51x635x508]
Refrigerant Charge Oz. [g]	205/211 [5812/5982]	205/211 [5812/5982]	294/302 [8335/8562]	294/302 [8335/8562]
Weights				
Net Weight lbs. [kg]	1826 [828]	1855 [841]	2013 [913]	2042 [926]
Ship Weight lbs. [kg]	1952 [885]	1981 [899]	2140 [971]	2160 [980]

NOTES:

- Cooling Performance is rated at 95° F ambient, 80° F entering dry bulb, 67° F entering wet bulb. Gross capacity does not include the effect of fan motor heat. AHRI capacity is net and includes the effect of fan motor heat. Units are suitable for operation to ±20% of nominal cfm. Units are certified in accordance with the Unitary Air Conditioner Equipment certification program, which is based on AHRI Standard 210/240 or 360.
- EER and/or SEER are rated at AHRI conditions and in accordance with DOE test procedures.
- Integrated Energy Efficiency Ratio (IEER) is rated in accordance with AHRI Standard 210/240 or 340/360.
- Not applicable to these units.
- Outdoor Sound Rating shown is tested in accordance with ARI Standard 270. 25 Ton Model is outside the scope of AHRI Standard 340/360.

GENERAL DATA - RLNL

Model RLNL- Series Model RKNL- Series (with VFD)	(B,C)210DL H210DR	(B,C)210DM H210DS	(B,C)210YL	(B,C)210YM
Cooling Performance¹				Continued ->
Gross Cooling Capacity Btu [kW]	212,000 [62.12]	212,000 [62.12]	212,000 [62.12]	212,000 [62.12]
EER, SEER ²	11.6/NA	11.6/NA	11.6/NA	11.6/NA
Nominal CFM/ARI Rated CFM [L/s]	7000/7025 [3303/3315]	7000/7025 [3303/3315]	7000/7025 [3303/3315]	7000/7025 [3303/3315]
ARI Net Cooling Capacity Btu [kW]	204,000 [59.77]	204,000 [59.77]	204,000 [59.77]	204,000 [59.77]
Net Sensible Capacity Btu [kW]	154,900 [45.39]	154,900 [45.39]	154,900 [45.39]	154,900 [45.39]
Net Latent Capacity Btu [kW]	49,100 [14.39]	49,100 [14.39]	49,100 [14.39]	49,100 [14.39]
IEER ³ (Standard / VFD)	12.6/14.5	12.6/14.5	12.6	12.6
Net System Power kW	17.57	17.57	17.57	17.57
Compressor				
No./Type	2/Scroll	2/Scroll	2/Scroll	2/Scroll
Outdoor Sound Rating (dB)⁵	91	91	91	91
Outdoor Coil - Fin Type	Louvered	Louvered	Louvered	Louvered
Tube Type	Rifled	Rifled	Rifled	Rifled
Tube Size in. [mm] OD	0.375 [9.5]	0.375 [9.5]	0.375 [9.5]	0.375 [9.5]
Face Area sq. ft. [sq. m]	53.3 [4.95]	53.3 [4.95]	53.3 [4.95]	53.3 [4.95]
Rows / FPI [FPcm]	2 / 18 [7]	2 / 18 [7]	2 / 18 [7]	2 / 18 [7]
Indoor Coil - Fin Type	Louvered	Louvered	Louvered	Louvered
Tube Type	Rifled	Rifled	Rifled	Rifled
Tube Size in. [mm]	0.375 [9.5]	0.375 [9.5]	0.375 [9.5]	0.375 [9.5]
Face Area sq. ft. [sq. m]	26.67 [2.48]	26.67 [2.48]	26.67 [2.48]	26.67 [2.48]
Rows / FPI [FPcm]	2 / 18 [7]	2 / 18 [7]	2 / 18 [7]	2 / 18 [7]
Refrigerant Control	TX Valves	TX Valves	TX Valves	TX Valves
Drain Connection No./Size in. [mm]	1/1 [25.4]	1/1 [25.4]	1/1 [25.4]	1/1 [25.4]
Outdoor Fan - Type	Propeller	Propeller	Propeller	Propeller
No. Used/Diameter in. [mm]	4/24 [609.6]	4/24 [609.6]	4/24 [609.6]	4/24 [609.6]
Drive Type/No. Speeds	Direct/1	Direct/1	Direct/1	Direct/1
CFM [L/s]	14800 [6984]	14800 [6984]	14800 [6984]	14800 [6984]
No. Motors/HP	4 at 1/3 HP	4 at 1/3 HP	4 at 1/3 HP	4 at 1/3 HP
Motor RPM	1075	1075	1075	1075
Indoor Fan - Type	FC Centrifugal	FC Centrifugal	FC Centrifugal	FC Centrifugal
No. Used/Diameter in. [mm]	2/18x9 [457x229]	2/18x9 [457x229]	2/18x9 [457x229]	2/18x9 [457x229]
Drive Type	Belt (Adjustable)	Belt (Adjustable)	Belt (Adjustable)	Belt (Adjustable)
No. Speeds (Standard / VFD)	Single / Multiple	Single / Multiple	Single	Single
No. Motors	1	1	1	1
Motor HP	3	5	3	5
Motor RPM	1725	1725	1725	1725
Motor Frame Size	56	184	56	184
Filter - Type	Disposable	Disposable	Disposable	Disposable
Furnished	Yes	Yes	Yes	Yes
(NO.) Size Recommended in. [mm x mm x mm]	(8)2x25x20 [51x635x508]	(8)2x25x20 [51x635x508]	(8)2x25x20 [51x635x508]	(8)2x25x20 [51x635x508]
Refrigerant Charge Oz. [g]	296/302 [8392/8562]	294/302 [8335/8562]	294/302 [8335/8562]	294/302 [8335/8562]
Weights				
Net Weight lbs. [kg]	2013 [913]	2042 [926]	2013 [913]	2042 [926]
Ship Weight lbs. [kg]	2140 [971]	2160 [980]	2140 [971]	2160 [980]

NOTES:

- Cooling Performance is rated at 95° F ambient, 80° F entering dry bulb, 67° F entering wet bulb. Gross capacity does not include the effect of fan motor heat. AHRI capacity is net and includes the effect of fan motor heat. Units are suitable for operation to ±20% of nominal cfm. Units are certified in accordance with the Unitary Air Conditioner Equipment certification program, which is based on AHRI Standard 210/240 or 360.
- EER and/or SEER are rated at AHRI conditions and in accordance with DOE test procedures.
- Integrated Energy Efficiency Ratio (IEER) is rated in accordance with AHRI Standard 210/240 or 340/360.
- Not applicable to these units.
- Outdoor Sound Rating shown is tested in accordance with ARI Standard 270. 25 Ton Model is outside the scope of AHRI Standard 340/360.

GENERAL DATA - RLNL

Model RLNL- Series Model RKNL- Series (with VFD)	(B,C)240CL H240CR	(B,C)240CM H240CS	(B,C)240CN H240CT	(B,C)240DL H240DR
Cooling Performance¹				Continued ->
Gross Cooling Capacity Btu [kW]	244,000 [71.49]	244,000 [71.49]	244,000 [71.49]	244,000 [71.49]
EER, SEER ²	11.1/NA	11.1/NA	11.1/NA	11.1/NA
Nominal CFM/ARI Rated CFM [L/s]	8000/7725 [3775/3645]	8000/7725 [3775/3645]	8000/7725 [3775/3645]	8000/7725 [3775/3645]
ARI Net Cooling Capacity Btu [kW]	234,000 [68.56]	234,000 [68.56]	234,000 [68.56]	234,000 [68.56]
Net Sensible Capacity Btu [kW]	171,600 [50.28]	171,600 [50.28]	171,600 [50.28]	171,600 [50.28]
Net Latent Capacity Btu [kW]	62,400 [18.28]	62,400 [18.28]	62,400 [18.28]	62,400 [18.28]
IEER ³ (Standard / VFD)	11.4/14.8	11.4/14.8	11.4/14.8	11.4/14.8
Net System Power kW	21.04	21.04	21.04	21.04
Compressor				
No./Type	2/Scroll	2/Scroll	2/Scroll	2/Scroll
Outdoor Sound Rating (dB)⁵	91	91	91	91
Outdoor Coil - Fin Type	Louvered	Louvered	Louvered	Louvered
Tube Type	Rifled	Rifled	Rifled	Rifled
Tube Size in. [mm] OD	0.375 [9.5]	0.375 [9.5]	0.375 [9.5]	0.375 [9.5]
Face Area sq. ft. [sq. m]	53.3 [4.95]	53.3 [4.95]	53.3 [4.95]	53.3 [4.95]
Rows / FPI [FPcm]	2 / 22 [9]	2 / 22 [9]	2 / 22 [9]	2 / 22 [9]
Indoor Coil - Fin Type	Louvered	Louvered	Louvered	Louvered
Tube Type	Rifled	Rifled	Rifled	Rifled
Tube Size in. [mm]	0.375 [9.5]	0.375 [9.5]	0.375 [9.5]	0.375 [9.5]
Face Area sq. ft. [sq. m]	26.67 [2.48]	26.67 [2.48]	26.67 [2.48]	26.67 [2.48]
Rows / FPI [FPcm]	3 / 13 [5]	3 / 13 [5]	3 / 13 [5]	3 / 13 [5]
Refrigerant Control	TX Valves	TX Valves	TX Valves	TX Valves
Drain Connection No./Size in. [mm]	1/1 [25.4]	1/1 [25.4]	1/1 [25.4]	1/1 [25.4]
Outdoor Fan - Type	Propeller	Propeller	Propeller	Propeller
No. Used/Diameter in. [mm]	6/24 [609.6]	6/24 [609.6]	6/24 [609.6]	6/24 [609.6]
Drive Type/No. Speeds	Direct/1	Direct/1	Direct/1	Direct/1
CFM [L/s]	19800 [9344]	19800 [9344]	19800 [9344]	19800 [9344]
No. Motors/HP	6 at 1/3 HP	6 at 1/3 HP	6 at 1/3 HP	6 at 1/3 HP
Motor RPM	1075	1075	1075	1075
Indoor Fan - Type	FC Centrifugal	FC Centrifugal	FC Centrifugal	FC Centrifugal
No. Used/Diameter in. [mm]	2/18x9 [457x229]	2/18x9 [457x229]	2/18x9 [457x229]	2/18x9 [457x229]
Drive Type	Belt (Adjustable)	Belt (Adjustable)	Belt (Adjustable)	Belt (Adjustable)
No. Speeds (Standard / VFD)	Single / Multiple	Single / Multiple	Single / Multiple	Single / Multiple
No. Motors	1	1	1	1
Motor HP	5	7 1/2	7 1/2	5
Motor RPM	1725	1725	1725	1725
Motor Frame Size	184	213	213	184
Filter - Type	Disposable	Disposable	Disposable	Disposable
Furnished	Yes	Yes	Yes	Yes
(NO.) Size Recommended in. [mm x mm x mm]	(8)2x25x20 [51x635x508]	(8)2x25x20 [51x635x508]	(8)2x25x20 [51x635x508]	(8)2x25x20 [51x635x508]
Refrigerant Charge Oz. [g]	402/331 [11397/9384]	402/331 [11397/9384]	402/331 [11397/9384]	402/331 [11397/9384]
Weights				
Net Weight lbs. [kg]	2151 [976]	2189 [993]	2187 [992]	2151 [976]
Ship Weight lbs. [kg]	2277 [1033]	2315 [1050]	2314 [1050]	2277 [1033]

NOTES:

- Cooling Performance is rated at 95° F ambient, 80° F entering dry bulb, 67° F entering wet bulb. Gross capacity does not include the effect of fan motor heat. AHRI capacity is net and includes the effect of fan motor heat. Units are suitable for operation to ±20% of nominal cfm. Units are certified in accordance with the Unitary Air Conditioner Equipment certification program, which is based on AHRI Standard 210/240 or 360.
- EER and/or SEER are rated at AHRI conditions and in accordance with DOE test procedures.
- Integrated Energy Efficiency Ratio (IEER) is rated in accordance with AHRI Standard 210/240 or 340/360.
- Not applicable to these units.
- Outdoor Sound Rating shown is tested in accordance with ARI Standard 270. 25 Ton Model is outside the scope of AHRI Standard 340/360.

GENERAL DATA - RLNL

Model RLNL- Series Model RKNL- Series (with VFD)	(B,C)240DM H240DS	(B,C)240DN H240DT	(B,C)240YL	(B,C)240YM
Cooling Performance¹				Continued ->
Gross Cooling Capacity Btu [kW]	244,000 [71.49]	244,000 [71.49]	244,000 [71.49]	244,000 [71.49]
EER, SEER ²	11.1/NA	11.1/NA	11.1/NA	11.1/NA
Nominal CFM/ARI Rated CFM [L/s]	8000/7725 [3775/3645]	8000/7725 [3775/3645]	8000/7725 [3775/3645]	8000/7725 [3775/3645]
ARI Net Cooling Capacity Btu [kW]	234,000 [68.56]	234,000 [68.56]	234,000 [68.56]	234,000 [68.56]
Net Sensible Capacity Btu [kW]	171,600 [50.28]	171,600 [50.28]	171,600 [50.28]	171,600 [50.28]
Net Latent Capacity Btu [kW]	62,400 [18.28]	62,400 [18.28]	62,400 [18.28]	62,400 [18.28]
IEER ³ (Standard / VFD)	11.4/14.8	11.4/14.8	11.4	11.4
Net System Power kW	21.04	21.04	21.04	21.04
Compressor				
No./Type	2/Scroll	2/Scroll	2/Scroll	2/Scroll
Outdoor Sound Rating (dB)⁵	91	91	91	91
Outdoor Coil - Fin Type	Louvered	Louvered	Louvered	Louvered
Tube Type	Rifled	Rifled	Rifled	Rifled
Tube Size in. [mm] OD	0.375 [9.5]	0.375 [9.5]	0.375 [9.5]	0.375 [9.5]
Face Area sq. ft. [sq. m]	53.3 [4.95]	53.3 [4.95]	53.3 [4.95]	53.3 [4.95]
Rows / FPI [FPcm]	2 / 22 [9]	2 / 22 [9]	2 / 22 [9]	2 / 22 [9]
Indoor Coil - Fin Type	Louvered	Louvered	Louvered	Louvered
Tube Type	Rifled	Rifled	Rifled	Rifled
Tube Size in. [mm]	0.375 [9.5]	0.375 [9.5]	0.375 [9.5]	0.375 [9.5]
Face Area sq. ft. [sq. m]	26.67 [2.48]	26.67 [2.48]	26.67 [2.48]	26.67 [2.48]
Rows / FPI [FPcm]	3 / 13 [5]	3 / 13 [5]	3 / 13 [5]	3 / 13 [5]
Refrigerant Control	TX Valves	TX Valves	TX Valves	TX Valves
Drain Connection No./Size in. [mm]	1/1 [25.4]	1/1 [25.4]	1/1 [25.4]	1/1 [25.4]
Outdoor Fan - Type	Propeller	Propeller	Propeller	Propeller
No. Used/Diameter in. [mm]	6/24 [609.6]	6/24 [609.6]	6/24 [609.6]	6/24 [609.6]
Drive Type/No. Speeds	Direct/1	Direct/1	Direct/1	Direct/1
CFM [L/s]	19800 [9344]	19800 [9344]	19800 [9344]	19800 [9344]
No. Motors/HP	6 at 1/3 HP	6 at 1/3 HP	6 at 1/3 HP	6 at 1/3 HP
Motor RPM	1075	1075	1075	1075
Indoor Fan - Type	FC Centrifugal	FC Centrifugal	FC Centrifugal	FC Centrifugal
No. Used/Diameter in. [mm]	2/18x9 [457x229]	2/18x9 [457x229]	2/18x9 [457x229]	2/18x9 [457x229]
Drive Type	Belt (Adjustable)	Belt (Adjustable)	Belt (Adjustable)	Belt (Adjustable)
No. Speeds (Standard / VFD)	Single / Multiple	Single / Multiple	Single	Single
No. Motors	1	1	1	1
Motor HP	7 1/2	7 1/2	5	7 1/2
Motor RPM	1725	1725	1725	1725
Motor Frame Size	184	184	184	213
Filter - Type	Disposable	Disposable	Disposable	Disposable
Furnished	Yes	Yes	Yes	Yes
(NO.) Size Recommended in. [mm x mm x mm]	(8)2x25x20 [51x635x508]	(8)2x25x20 [51x635x508]	(8)2x25x20 [51x635x508]	(8)2x25x20 [51x635x508]
Refrigerant Charge Oz. [g]	402/331 [11397/9384]	402/331 [11397/9384]	402/331 [11397/9384]	402/331 [11397/9384]
Weights				
Net Weight lbs. [kg]	2189 [993]	2187 [992]	2151 [976]	2189 [993]
Ship Weight lbs. [kg]	2315 [1050]	2314 [1050]	2277 [1033]	2315 [1050]

NOTES:

- Cooling Performance is rated at 95° F ambient, 80° F entering dry bulb, 67° F entering wet bulb. Gross capacity does not include the effect of fan motor heat. AHRI capacity is net and includes the effect of fan motor heat. Units are suitable for operation to ±20% of nominal cfm. Units are certified in accordance with the Unitary Air Conditioner Equipment certification program, which is based on AHRI Standard 210/240 or 360.
- EER and/or SEER are rated at AHRI conditions and in accordance with DOE test procedures.
- Integrated Energy Efficiency Ratio (IEER) is rated in accordance with AHRI Standard 210/240 or 340/360.
- Not applicable to these units.
- Outdoor Sound Rating shown is tested in accordance with ARI Standard 270. 25 Ton Model is outside the scope of AHRI Standard 340/360.

GENERAL DATA - RLNL

Model RLNL- Series Model RKNL- Series (with VFD)	(B,C)240YN	(B,C)300CL H300CR	(B,C)300CM H300CS	(B,C)300DL H300DR
Cooling Performance¹				Continued ->
Gross Cooling Capacity Btu [kW]	244,000 [71.49]	312,000 [91.42]	312,000 [91.42]	312,000 [91.42]
EER, SEER ²	11.1/NA	10/NA	10/NA	10/NA
Nominal CFM/ARI Rated CFM [L/s]	8000/7725 [3775/3645]	10000/9475 [4719/4471]	10000/9475 [4719/4471]	10000/9475 [4719/4471]
ARI Net Cooling Capacity Btu [kW]	234,000 [68.56]	294,000 [86.14]	294,000 [86.14]	294,000 [86.14]
Net Sensible Capacity Btu [kW]	171,600 [50.28]	214,100 [62.73]	214,100 [62.73]	214,100 [62.73]
Net Latent Capacity Btu [kW]	62,400 [18.28]	79,900 [23.41]	79,900 [23.41]	79,900 [23.41]
IEER ³ (Standard / VFD)	11.4	10.1/14.1	10.1/14.1	10.1/14.1
Net System Power kW	21.04	29.39	29.39	29.39
Compressor				
No./Type	2/Scroll	2/Scroll	2/Scroll	2/Scroll
Outdoor Sound Rating (dB)⁵	91	92	92	92
Outdoor Coil - Fin Type	Louvered	Louvered	Louvered	Louvered
Tube Type	Rifled	Rifled	Rifled	Rifled
Tube Size in. [mm] OD	0.375 [9.5]	0.375 [9.5]	0.375 [9.5]	0.375 [9.5]
Face Area sq. ft. [sq. m]	53.3 [4.95]	53.3 [4.95]	53.3 [4.95]	53.3 [4.95]
Rows / FPI [FPcm]	2 / 22 [9]	2 / 22 [9]	2 / 22 [9]	2 / 22 [9]
Indoor Coil - Fin Type	Louvered	Louvered	Louvered	Louvered
Tube Type	Rifled	Rifled	Rifled	Rifled
Tube Size in. [mm]	0.375 [9.5]	0.375 [9.5]	0.375 [9.5]	0.375 [9.5]
Face Area sq. ft. [sq. m]	26.67 [2.48]	26.67 [2.48]	26.67 [2.48]	26.67 [2.48]
Rows / FPI [FPcm]	3 / 13 [5]	4 / 15 [6]	4 / 15 [6]	4 / 15 [6]
Refrigerant Control	TX Valves	TX Valves	TX Valves	TX Valves
Drain Connection No./Size in. [mm]	1/1 [25.4]	1/1 [25.4]	1/1 [25.4]	1/1 [25.4]
Outdoor Fan - Type	Propeller	Propeller	Propeller	Propeller
No. Used/Diameter in. [mm]	6/24 [609.6]	6/24 [609.6]	6/24 [609.6]	6/24 [609.6]
Drive Type/No. Speeds	Direct/1	Direct/1	Direct/1	Direct/1
CFM [L/s]	19800 [9344]	19800 [9344]	19800 [9344]	19800 [9344]
No. Motors/HP	6 at 1/3 HP	6 at 1/3 HP	6 at 1/3 HP	6 at 1/3 HP
Motor RPM	1075	1075	1075	1075
Indoor Fan - Type	FC Centrifugal	FC Centrifugal	FC Centrifugal	FC Centrifugal
No. Used/Diameter in. [mm]	2/18x9 [457x229]	2/18x9 [457x229]	2/18x9 [457x229]	2/18x9 [457x229]
Drive Type	Belt (Adjustable)	Belt (Adjustable)	Belt (Adjustable)	Belt (Adjustable)
No. Speeds (Standard / VFD)	Single	Single / Multiple	Single / Multiple	Single / Multiple
No. Motors	1	1	1	1
Motor HP	7 1/2	7 1/2	10	7 1/2
Motor RPM	1725	1725	1725	1725
Motor Frame Size	213	213	215	213
Filter - Type	Disposable	Disposable	Disposable	Disposable
Furnished	Yes	Yes	Yes	Yes
(NO.) Size Recommended in. [mm x mm x mm]	(8)2x25x20 [51x635x508]	(8)2x25x20 [51x635x508]	(8)2x25x20 [51x635x508]	(8)2x25x20 [51x635x508]
Refrigerant Charge Oz. [g]	402/331 [11397/9384]	339/357 [9611/10121]	339/357 [9611/10121]	339/357 [9611/10121]
Weights				
Net Weight lbs. [kg]	2187 [992]	2250 [1021]	2261 [1026]	2250 [1021]
Ship Weight lbs. [kg]	2314 [1050]	2376 [1078]	2387 [1083]	2376 [1078]

NOTES:

- Cooling Performance is rated at 95° F ambient, 80° F entering dry bulb, 67° F entering wet bulb. Gross capacity does not include the effect of fan motor heat. AHRI capacity is net and includes the effect of fan motor heat. Units are suitable for operation to ±20% of nominal cfm. Units are certified in accordance with the Unitary Air Conditioner Equipment certification program, which is based on AHRI Standard 210/240 or 360.
- EER and/or SEER are rated at AHRI conditions and in accordance with DOE test procedures.
- Integrated Energy Efficiency Ratio (IEER) is rated in accordance with AHRI Standard 210/240 or 340/360.
- Not applicable to these units.
- Outdoor Sound Rating shown is tested in accordance with ARI Standard 270. 25 Ton Model is outside the scope of AHRI Standard 340/360.

GENERAL DATA - RLNL

Model RLNL- Series Model RKNL- Series (with VFD)	(B,C)300DM H300DS	(B,C)300YL	(B,C)300YM
Cooling Performance¹			
Gross Cooling Capacity Btu [kW]	312,000 [91.42]	312,000 [91.42]	312,000 [91.42]
EER, SEER ²	10/NA	10/NA	10/NA
Nominal CFM/ARI Rated CFM [L/s]	10000/9475 [4719/4471]	10000/9475 [4719/4471]	10000/9475 [4719/4471]
ARI Net Cooling Capacity Btu [kW]	294,000 [86.14]	294,000 [86.14]	294,000 [86.14]
Net Sensible Capacity Btu [kW]	214,100 [62.73]	214,100 [62.73]	214,100 [62.73]
Net Latent Capacity Btu [kW]	79,900 [23.41]	79,900 [23.41]	79,900 [23.41]
IEER ³ (Standard / VFD)	10.1/14.1	10.1	10.1
Net System Power kW	29.39	29.39	29.39
Compressor			
No./Type	2/Scroll	2/Scroll	2/Scroll
Outdoor Sound Rating (dB)⁵			
	92	92	92
Outdoor Coil - Fin Type			
Tube Type	Louvered	Louvered	Louvered
Tube Size in. [mm] OD	Rifled	Rifled	Rifled
Face Area sq. ft. [sq. m]	0.375 [9.5]	0.375 [9.5]	0.375 [9.5]
Rows / FPI [FPcm]	53.3 [4.95]	53.3 [4.95]	53.3 [4.95]
	2 / 22 [9]	2 / 22 [9]	2 / 22 [9]
Indoor Coil - Fin Type			
Tube Type	Louvered	Louvered	Louvered
Tube Size in. [mm]	Rifled	Rifled	Rifled
Face Area sq. ft. [sq. m]	0.375 [9.5]	0.375 [9.5]	0.375 [9.5]
Rows / FPI [FPcm]	26.67 [2.48]	26.67 [2.48]	26.67 [2.48]
Refrigerant Control	4 / 15 [6]	4 / 15 [6]	4 / 15 [6]
Drain Connection No./Size in. [mm]	TX Valves	TX Valves	TX Valves
	1/1 [25.4]	1/1 [25.4]	1/1 [25.4]
Outdoor Fan - Type			
No. Used/Diameter in. [mm]	Propeller	Propeller	Propeller
Drive Type/No. Speeds	6/24 [609.6]	6/24 [609.6]	6/24 [609.6]
CFM [L/s]	Direct/1	Direct/1	Direct/1
No. Motors/HP	19800 [9344]	19800 [9344]	19800 [9344]
Motor RPM	6 at 1/3 HP	6 at 1/3 HP	6 at 1/3 HP
	1075	1075	1075
Indoor Fan - Type			
No. Used/Diameter in. [mm]	FC Centrifugal	FC Centrifugal	FC Centrifugal
Drive Type	2/18x9 [457x229]	2/18x9 [457x229]	2/18x9 [457x229]
No. Speeds (Standard / VFD)	Belt (Adjustable)	Belt (Adjustable)	Belt (Adjustable)
No. Motors	Single / Multiple	Single	Single
Motor HP	1	1	1
Motor RPM	10	7 1/2	10
Motor Frame Size	1725	1725	1725
	215	213	215
Filter - Type			
Furnished	Disposable	Disposable	Disposable
(NO.) Size Recommended in. [mm x mm x mm]	Yes	Yes	Yes
	(8)2x25x20 [51x635x508]	(8)2x25x20 [51x635x508]	(8)2x25x20 [51x635x508]
Refrigerant Charge Oz. [g]			
	339/357 [9611/10121]	339/357 [9611/10121]	339/357 [9611/10121]
Weights			
Net Weight lbs. [kg]	2261 [1026]	2250 [1021]	2261 [1026]
Ship Weight lbs. [kg]	2387 [1083]	2376 [1078]	2387 [1083]

NOTES:

- Cooling Performance is rated at 95° F ambient, 80° F entering dry bulb, 67° F entering wet bulb. Gross capacity does not include the effect of fan motor heat. AHRI capacity is net and includes the effect of fan motor heat. Units are suitable for operation to ±20% of nominal cfm. Units are certified in accordance with the Unitary Air Conditioner Equipment certification program, which is based on AHRI Standard 210/240 or 360.
- EER and/or SEER are rated at AHRI conditions and in accordance with DOE test procedures.
- Integrated Energy Efficiency Ratio (IEER) is rated in accordance with AHRI Standard 210/240 or 340/360.
- Not applicable to these units.
- Outdoor Sound Rating shown is tested in accordance with ARI Standard 270. 25 Ton Model is outside the scope of AHRI Standard 340/360.

ELECTRICAL DATA - RLNL

ELECTRICAL DATA - RLNL SERIES										
		B180CL/ C180CL/ H180CR	B180CM/ C180CM/ H180CS	B180DL/ C180DL/ H180DR	B180DM/ C180DM/ H180DS	B180YL/ C180YL/ —	B180YM/ C180YM/ —	B210CL/ C210CL/ H210CR	B210CM/ C210CM/ H210CS	B210DL/ C210DL/ H210DR
Unit Information	Unit Operating Voltage Range	187-253	187-253	414-506	414-506	518-632	518-632	187-253	187-253	414-506
	Volts	208/230	208/230	460	460	575	575	208/230	208/230	460
	Minimum Circuit Ampacity	78/78	81/81	38	40	28	30	88/88	91/91	44
	Minimum Overcurrent Protection Device Size	90/90	90/90	45	45	30	35	100/100	100/100	50
	Maximum Overcurrent Protection Device Size	100/100	100/100	45	50	35	35	110/110	110/110	50
Compressor Motor	No.	2	2	2	2	2	2	2	2	2
	Volts	200/230	200/230	460	460	575	575	200/230	200/230	460
	Phase	3	3	3	3	3	3	3	3	3
	RPM	3450	3450	3450	3450	3450	3450	3450	3450	3450
	HP, Compressor 1	7	7	7	7	7	7	7 1/2	7 1/2	7 1/2
	Amps (RLA), Comp. 1	25/25	25/25	12.2	12.2	9	9	29.5/29.5	29.5/29.5	14.7
	Amps (LRA), Comp. 1	164/164	164/164	100	100	78	78	195/195	195/195	95
	HP, Compressor 2	7	7	7	7	7	7	7 1/2	7 1/2	7 1/2
	Amps (RLA), Comp. 2	25/25	25/25	12.2	12.2	9	9	29.5/29.5	29.5/29.5	14.7
	Amps (LRA), Comp. 2	164/164	164/164	100	100	78	78	195/195	195/195	95
Condenser Motor	No.	4	4	4	4	4	4	4	4	4
	Volts	208/230	208/230	460	460	575	575	208/230	208/230	460
	Phase	1	1	1	1	1	1	1	1	1
	HP	1/3	1/3	1/3	1/3	1/3	1/3	1/3	1/3	1/3
	Amps (FLA, each)	2.4/2.4	2.4/2.4	1.4	1.4	1	1	2.4/2.4	2.4/2.4	1.4
	Amps (LRA, each)	4.7/4.7	4.7/4.7	2.4	2.4	1.8	1.8	4.7/4.7	4.7/4.7	2.4
Evaporator Fan	No.	1	1	1	1	1	1	1	1	1
	Volts	208/230	208/230	460	460	575	575	208/230	208/230	460
	Phase	3	3	3	3	3	3	3	3	3
	HP	3	5	3	5	3	5	3	5	3
	Amps (FLA, each)	11.5/11.5	14.9/14.9	4.6	6.6	3.5	5.3	11.5/11.5	14.9/14.9	4.6
	Amps (LRA, each)	74.5/74.5	82.6/82.6	38.1	46.3	20	39.4	74.5/74.5	82.6/82.6	38.1

ELECTRICAL DATA - RLNL (continued)

ELECTRICAL DATA - RLNL SERIES											
		B210DM/ C210DM/ H210DS	B210YL/ C210YL/ —	B210YM/ C210YM/ —	B240CL/ C240CL/ H240CR	B240CM/ C240CM/ H240CS	B240CN/ C240CN/ H240CT	B240DL/ C240DL/ H240DR	B240DM/ C240DM/ H240DS	B240DN/ C240DN/ H240DT	B240YL/ C240YL/ —
Unit Information	Unit Operating Voltage Range	414-506	518-632	518-632	187-253	187-253	187-253	414-506	414-506	414-506	518-632
	Volts	460	575	575	208/230	208/230	208/230	460	460	460	575
	Minimum Circuit Ampacity	46	35	37	101/101	109/109	109/109	52	56	56	40
	Minimum Overcurrent Protection Device Size	50	40	40	110/110	125/125	125/125	60	60	60	45
	Maximum Overcurrent Protection Device Size	50	45	45	125/125	125/125	125/125	60	70	70	50
Compressor Motor	No.	2	2	2	2	2	2	2	2	2	2
	Volts	460	575	575	200/230	200/230	200/230	460	460	460	575
	Phase	3	3	3	3	3	3	3	3	3	3
	RPM	3450	3450	3450	3450	3450	3450	3450	3450	3450	3450
	HP, Compressor 1	7 1/2	7 1/2	7 1/2	10	10	10	10	10	10	10
	Amps (RLA), Comp. 1	14.7	12.2	12.2	33.3/33.3	33.3/33.3	33.3/33.3	17.9	17.9	17.9	12.8
	Amps (LRA), Comp. 1	95	80	80	239/239	239/239	239/239	125	125	125	80
	HP, Compressor 2	7 1/2	7 1/2	7 1/2	7 1/2	7 1/2	7 1/2	7 1/2	7 1/2	7 1/2	7 1/2
	Amps (RLA), Comp. 2	14.7	12.2	12.2	29.5/29.5	29.5/29.5	29.5/29.5	14.7	14.7	14.7	12.2
	Amps (LRA), Comp. 2	95	80	80	195/195	195/195	195/195	95	95	95	80
Condenser Motor	No.	4	4	4	6	6	6	6	6	6	6
	Volts	460	575	575	208/230	208/230	208/230	460	460	460	575
	Phase	1	1	1	1	1	1	1	1	1	1
	HP	1/3	1/3	1/3	1/3	1/3	1/3	1/3	1/3	1/3	1/3
	Amps (FLA, each)	1.4	1	1	2.4/2.4	2.4/2.4	2.4/2.4	1.4	1.4	1.4	1
	Amps (LRA, each)	2.4	1.8	1.8	4.7/4.7	4.7/4.7	4.7/4.7	2.4	2.4	2.4	1.8
Evaporator Fan	No.	1	1	1	1	1	1	1	1	1	1
	Volts	460	575	575	208/230	208/230	208/230	460	460	460	575
	Phase	3	3	3	3	3	3	3	3	3	3
	HP	5	3	5	5	7 1/2	7 1/2	5	7 1/2	7 1/2	5
	Amps (FLA, each)	6.6	3.5	5.3	14.7/14.7	23.1/23.1	23.1/23.1	6.6	9.6	9.6	5.3
	Amps (LRA, each)	46.3	20	39.4	82.6/82.6	136/136	136/136	46.3	67	67	39.4

ELECTRICAL DATA - RLNL (continued)

ELECTRICAL DATA - RLNL SERIES									
		B240YM/ C240YM/ —	B240YN/ C240YN/ —	B300CL/ C300CL/ H300CR	B300CM/ C300CM/ H300CS	B300DL/ C300DL/ H300DR	B300DM/ C300DM/ H300DS	B300YL/ C300YL/ —	B300YM/ C300YM/ —
Unit Information	Unit Operating Voltage Range	518-632	518-632	187-253	187-253	414-506	414-506	518-632	518-632
	Volts	575	575	208/230	208/230	460	460	575	575
	Minimum Circuit Ampacity	42	42	147/147	149/149	60	63	47	50
	Minimum Overcurrent Protection Device Size	50	50	175/175	175/175	70	70	60	60
	Maximum Overcurrent Protection Device Size	50	50	175/175	175/175	70	80	60	60
Compressor Motor	No.	2	2	2	2	2	2	2	2
	Volts	575	575	200/240	200/240	460	460	575	575
	Phase	3	3	3	3	3	3	3	3
	RPM	3450	3450	3450	3450	3450	3450	3450	3450
	HP, Compressor 1	10	10	11 1/2	11 1/2	11 1/2	11 1/2	11 1/2	11 1/2
	Amps (RLA), Comp. 1	12.8	12.8	48.1/48.1	48.1/48.1	18.6	18.6	14.7	14.7
	Amps (LRA), Comp. 1	80	80	245/245	245/245	125	125	100	100
	HP, Compressor 2	7 1/2	7 1/2	11 1/2	11 1/2	11 1/2	11 1/2	11 1/2	11 1/2
	Amps (RLA), Comp. 2	12.2	12.2	48.1/48.1	48.1/48.1	18.6	18.6	14.7	14.7
	Amps (LRA), Comp. 2	80	80	245/245	245/245	125	125	100	100
Condenser Motor	No.	6	6	6	6	6	6	6	6
	Volts	575	575	208/230	208/230	460	460	575	575
	Phase	1	1	1	1	1	1	1	1
	HP	1/3	1/3	1/3	1/3	1/3	1/3	1/3	1/3
	Amps (FLA, each)	1	1	2.4/2.4	2/2	1.4	1.4	1	1
	Amps (LRA, each)	1.8	1.8	4.7/4.7	3.9/3.9	2.4	2.4	1.8	1.8
Evaporator Fan	No.	1	1	1	1	1	1	1	1
	Volts	575	575	208/230	208/230	460	460	575	575
	Phase	3	3	3	3	3	3	3	3
	HP	7 1/2	7 1/2	7 1/2	10	7 1/2	10	7 1/2	10
	Amps (FLA, each)	7.8	7.8	24.2/24.2	28.5/28.5	9.6	12.5	7.8	10
	Amps (LRA, each)	53.8	53.8	136/136	178/178	67	74.6	53.8	59.2

V. INSTALLATION

A. GENERAL

1. PRE-INSTALLATION CHECK-POINTS

Before attempting any installation, the following points should be carefully considered:

- a. Structural strength of supporting members. (rooftop installation)
- b. Clearances and provision for servicing.
- c. Power supply and wiring.
- d. Air duct connections.
- e. Drain facilities and connections.
- f. Location for minimum noise.

2. LOCATION

These units are designed for outdoor installations. They can be mounted on a slab or rooftop. They are not to be installed within any part of a structure such as an attic, crawl space, closet, or any other place where condenser air flow is restricted or other than outdoor ambient conditions prevail. Since the application of the units is of the outdoor type, it is important to consult your local code authorities at the time the first installation is made.

B. OUTSIDE SLAB INSTALLATION (Typical outdoor slab installations are shown in Figures 9 and 10.)

1. Select a location where external water drainage cannot collect around the unit.
2. Provide a level concrete slab extending 3" beyond all four sides of the unit. The slab should be sufficient above grade to prevent ground water from entering the unit. **IMPORTANT: To prevent transmission of noise or vibration, slab should not be connected to building structure.**
3. The location of the unit should be such as to provide proper access for inspection and servicing.
4. Locate unit where operating sounds will not disturb owner or neighbors.
5. Locate unit so roof runoff water does not pour directly on the unit. Provide gutter or other shielding at roof level. Do not locate unit in an area where excessive snow drifting may occur or accumulate.

C. CLEARANCES

The following minimum clearances must be observed for proper unit performance and serviceability.

FIGURE 9
PACKAGED AIR CONDITIONER
OUTSIDE SLAB INSTALLATION, BASEMENT OR CRAWL SPACE
DISTRIBUTION SYSTEM

RECOMMENDED CLEARANCE	LOCATION
80"	A - FRONT
18"	B - CONDENSER COIL
18/42"	+C - DUCT SIDE
18/48"	*D - EVAPORATOR END
60"	E - ABOVE
* WITHOUT ECONOMIZER/48" WITH ECONOMIZER	

+ WITHOUT HORIZONTAL ECONOMIZER/ 42" WITH HORIZONTAL ECONOMIZER

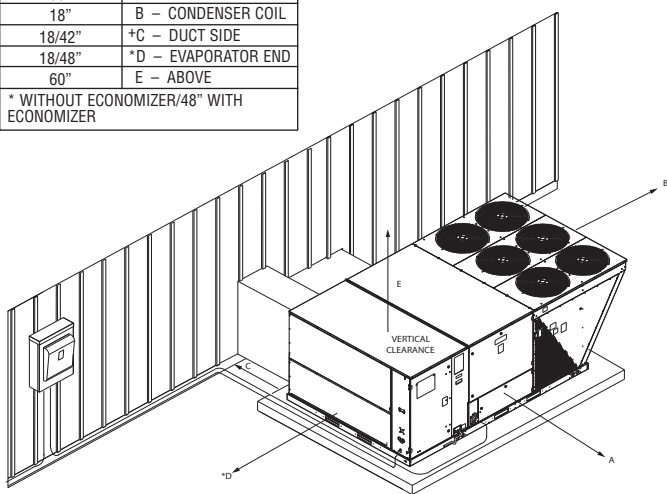

ST-A1125-29

FIGURE 10
PACKAGED AIR CONDITIONER
OUTSIDE SLAB INSTALLATION, CLOSET DISTRIBUTION SYSTEM. SLAB
FLOOR CONSTRUCTION

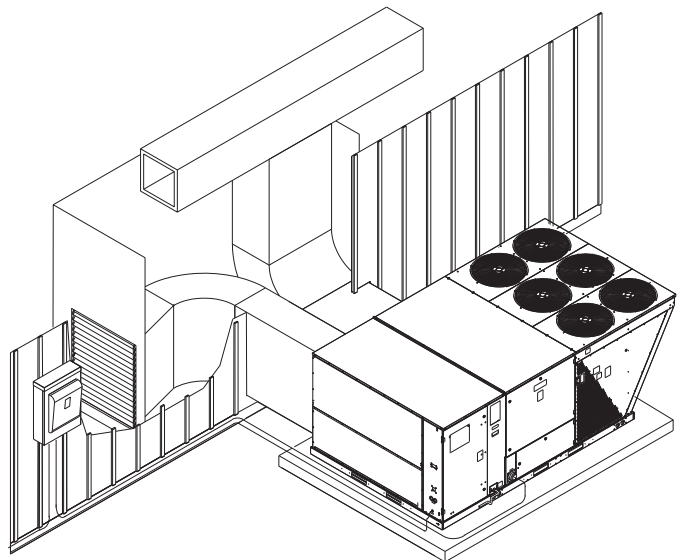

ST-A1125-30

FIGURE 11

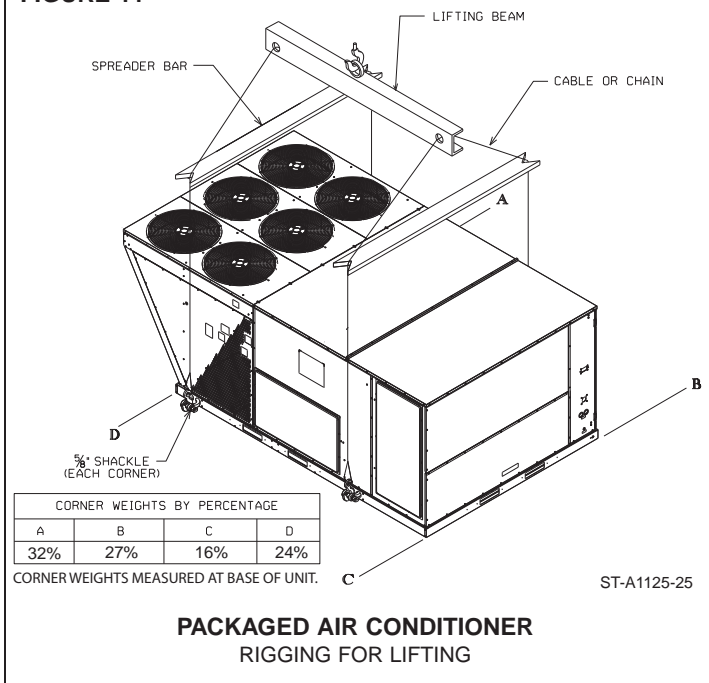

1. Provide 80" minimum clearance at the front of the unit to facilitate removal of the drain pan and return air filters. Provide 18" minimum clearance at all other sides of the unit.
2. Provide 60" minimum clearance between top of unit and maximum 3 foot overhang.
3. Unit is design certified for application on combustible flooring with 0" minimum clearance.
4. See Figure 9 for illustration of minimum installation-service clearances.

D. ROOFTOP INSTALLATION

1. Before locating the unit on the roof, make sure that the strength of the roof and beams is adequate at that point to support the weight involved. This is very important and user's responsibility.
2. For rigging and roofcurb details, see Figures 11 and 12. Use field-furnished spreaders.
3. For roofcurb assembly, see Roofcurb Installation Instructions.
4. If the roofcurb is not used, provisions for disposing of condensate water runoff must be provided.
5. The unit should be placed on a solid and level roofcurb or platform of adequate strength. See Figure 13.
6. The location of the unit on the roof should be such as to provide proper access for inspection and servicing.

IMPORTANT: If unit will not be put into service immediately, cover supply and return openings to prevent excessive condensation.

FIGURE 12

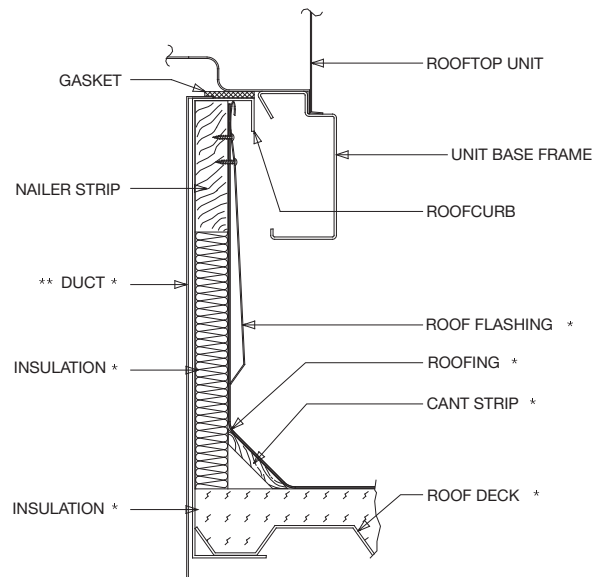
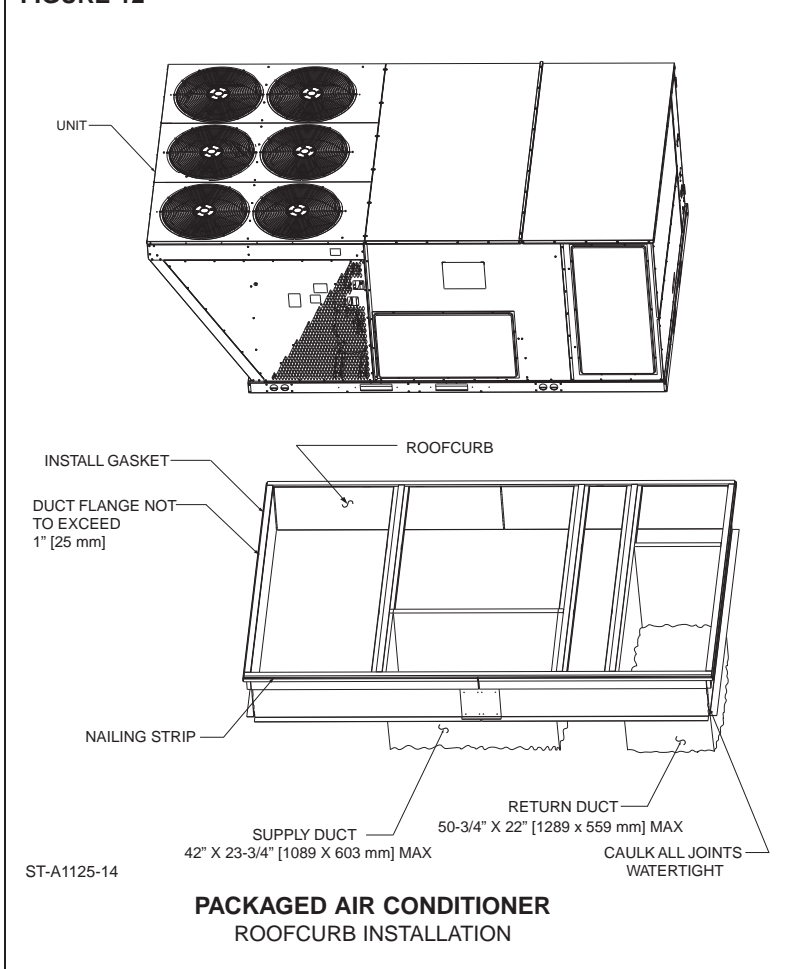

ST-A0888-02

* BY CONTRACTOR
** FOR INSTALLATION OF DUCT AS SHOWN, USE RECOMMENDED DUCT SIZES FROM ROOFCURB INSTALLATION INSTRUCTIONS. FOR DUCT FLANGE ATTACHMENT TO UNIT, SEE UNIT INSTALLATION INSTRUCTIONS FOR RECOMMENDED DUCT SIZES.

VI. DUCTWORK

Ductwork should be fabricated by the installing contractor in accordance with local codes and NFPA90A. Industry manuals may be used as a guide when sizing and designing the duct system - contact Air Conditioning Contractors of America, 2800 Shirlington Road, Suite 300, Arlington, VA 22206, <http://www.acca.org>.

The unit should be placed as close to the space to be air conditioned as possible allowing clearance dimensions as indicated. Ducts should be run as directly as possible to supply and return outlets. Use of non-flammable waterproof flexible connectors on both supply and return connections at the unit to reduce noise transmission is recommended.

It is preferable to install the unit on the roof of the structure if the registers or diffusers are located on the wall or in the ceiling. A slab installation could be considered when the registers are low on a wall or in the floor.

On ductwork exposed to outside air conditions of temperature and humidity, use a minimum of 2" of insulation and a vapor barrier. Distribution system in attic, furred space or crawl space should be insulated with at least 2" of insulation with vapor barrier. One-half to 1" thickness of insulation is usually sufficient for ductwork inside the air conditioned space.

Balancing dampers should be provided for each branch duct in the supply system. Ductwork should be properly supported from the structure.

When installing ductwork, consider the following items:

1. Noncombustible flexible connectors should be used between ductwork and unit to reduce noise and vibration transmission into the ductwork.
2. When auxiliary heaters are installed, use noncombustible flexible connectors and clearance to combustible material of 0" for the first 3 feet of discharge duct. Clearance to unit top and side is 0".

VII. FILTERS

This unit is provided with 8 - 20" x 25" x 2" disposable filters. When replacing filters, ensure they are inserted fully to the back to prevent bypass. See Figure 8.

Recommended supplier of this filter is Glassfloss Industries, Inc. or

AAF International
 215 Central Avenue
 P.O. Box 35690
 Louisville, KY 40232
 Phone: 1-800-501-3146
 Part #: 54-42541-04 (20" x 25" x 2")

FIGURE 13

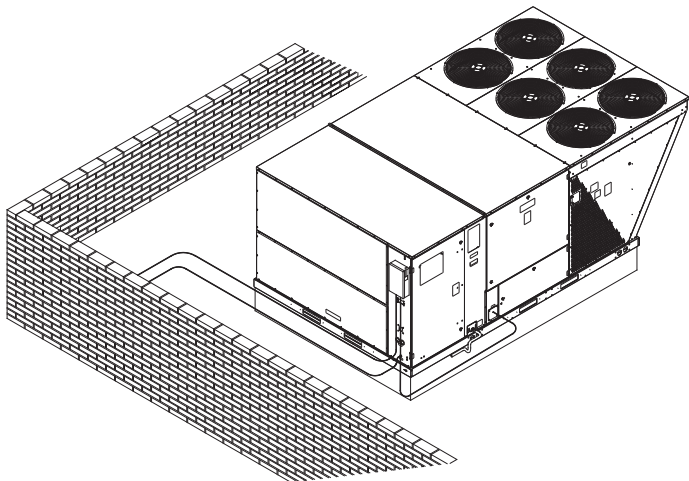

ST-A1125-01B

PACKAGED AIR CONDITIONER
 FLAT ROOFTOP INSTALLATION, ATTIC OR DROP CEILING
 DISTRIBUTION SYSTEM. MOUNTED ON
 ROOFCURB. CURB MUST BE LEVEL

FIGURE 14
 COVER GASKET DETAIL

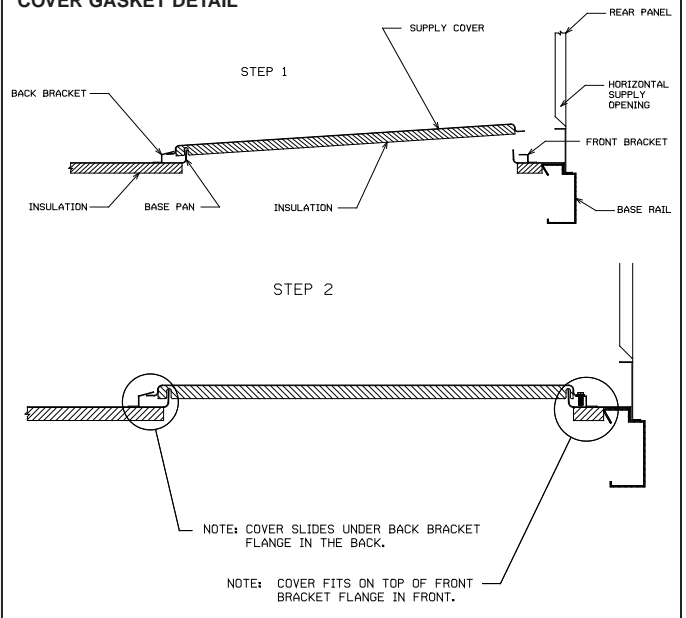

VIII. COVER PANEL INSTALLATION/ CONVERSION PROCEDURE

DOWNFLOW TO HORIZONTAL

1. Remove the screws and covers from the outside of the supply and return sections. Also remove and discard cover plate. See Figure 3.
2. Install the covers over the bottom supply and return openings, painted side up, inserting the **leading flange under the bracket provided**. Place the **back flange to top of the front bracket provided**. See Figure 14.
3. Secure the return and supply cover to front bracket with two (2) screws.

IX. CONDENSATE DRAIN

IMPORTANT: Install a condensate trap to ensure proper condensate drainage. See Figure 15.

The condensate drain pan has a threaded female 1 inch NPT (11.5 TPI) connection. Consult local codes or ordinances for specific requirements of condensate drain piping and disposal.

- To use the removable drain pan feature of this unit, some of the condensate line joints should be assembled for easy removal and cleaning.
- Use a thin layer of Teflon tape or paste on drain pan connections and install only hand tight.
- Do not over tighten drain pan connections as damage to the drain pan may occur.
- Drain line MUST NOT block service access panels.
- Drain line must be no smaller than drain pan outlet and adequately sized to accommodate the condensate discharge from the unit.
- Drain line should slope away from unit a minimum of 1/8" per foot to ensure proper drainage.
- Drain line must be routed to an acceptable drain or outdoors in accordance with local codes.
- Do not connect condensate drain line to a closed sewer pipe.
- Drain line may need insulation or freeze protection in certain applications.

X. ELECTRICAL WIRING

Field wiring must comply with the National Electrical Code* and local ordinances that may apply.

*C.E.C. in Canada

FIGURE 15
CONDENSATE DRAIN

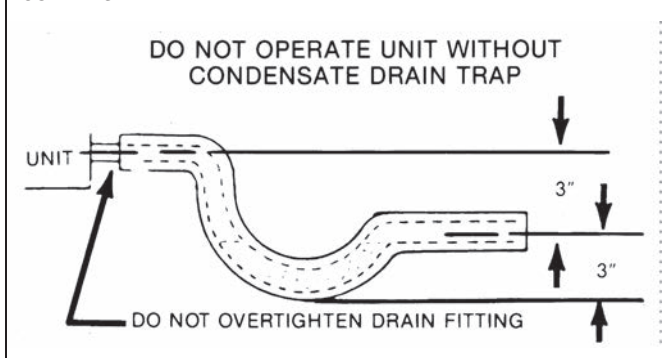
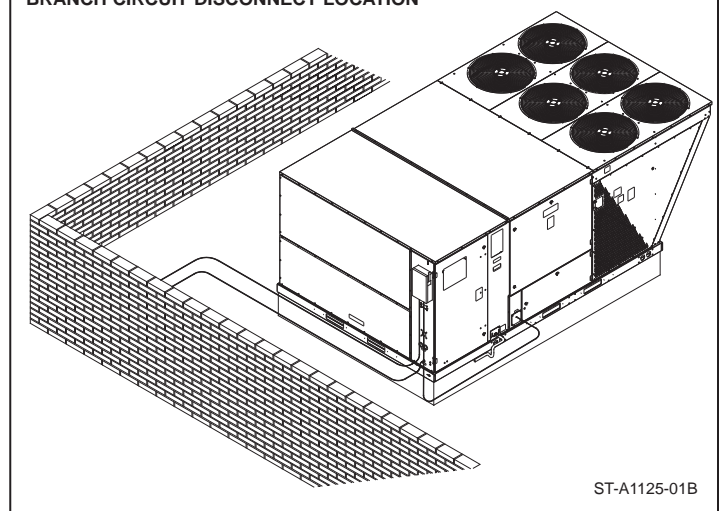

FIGURE 16
BRANCH CIRCUIT DISCONNECT LOCATION



WARNING

THE UNIT MUST BE PERMANENTLY GROUNDED. A GROUNDING LUG IS PROVIDED IN THE ELECTRIC HEAT ACCESS AREA FOR A GROUND WIRE. FAILURE TO GROUND THIS UNIT CAN RESULT IN FIRE OR ELECTRICAL SHOCK CAUSING PROPERTY DAMAGE, SEVERE PERSONAL INJURY OR DEATH.

A. POWER WIRING

1. This unit incorporates single-point electrical connections for the unit and electric heat accessory.
2. It is important that proper electrical power is available to the unit. Voltage should not vary more than 10% from the values marked on the unit rating plate. Phase voltages must be balanced within 3%.
3. Install a branch circuit disconnect within sight of the unit. See Figure 16. Use the unit rating plate or Tables A, B, C, and D to determine the required size.
4. The branch circuit wire must be sized in accordance with the National Electrical Code (C.E.C. in Canada) and local ordinances that may apply using the minimum circuit ampacity found on the unit rating plate.
5. Field-installed power wiring must be run through grounded rain-tight conduit attached to the unit power entry panel and connected as follows:

UNITS WITHOUT ELECTRIC HEAT - Connect power wiring to the power terminal block located on the left side of the electric heat compartment. Connect the ground wire to the adjacent ground lug.

UNITS WITH FACTORY INSTALLED ELECTRIC HEAT - Connect power wiring to the power terminal block located on the electric heater kit. Connect the ground wire to the adjacent ground lug. DO NOT connect aluminum wiring directly to the electric heater terminal block. Wiring to the unit contactors is factory-connected.

6. For field installation of an electric heater kit, follow the instructions below. Refer to the information supplied with the kit.
 - a. Removing screws as required, open heater access door and detach adjacent power entry panel.
 - b. Remove unit contactor wires (1L1, 1L2, 1L3) from unit terminal block on the left side of the electric heat compartment. Remove and discard the terminal block and the adjacent ground lug.
 - c. Remove the heater kit block-off panel and install the heater kit in its place using the screws previously removed.
 - d. Connect the unit contactor wires (1L1, 1L2, 1L3) to the compressor fuse block on the heater kit.
 - e. Re-install the power entry panel & run conduit and the proper size field wiring through the opening in the panel.
 - f. Connect field wiring to the power terminal block located on the electric heater kit. Connect ground wire to the adjacent ground lug.
 - g. Connect heater kit control plug to the receptacle on the control wiring harness.
 - h. Close heater access door and secure with screws previously removed.

B. CONTROL WIRING (Class II)

1. Low voltage wiring should not be run in conduit with power wiring.
2. Control wiring is routed through the 7/8" hole in the unit side panel. See Figure 7. Use a minimum #18 AWG thermostat wire. For wire lengths exceeding 50', use #16 AWG thermostat wire. Connect the control wiring to the low voltage terminal block located below the unit control box.
3. Recommended thermostats can be found in the thermostat specifications catalog T11-001.
4. Figure 18 shows representative low voltage connection diagrams. Read your thermostat installation instructions for any special requirements for your specific thermostat.

NOTE — Units installed in Canada require that an outdoor thermostat (30,000 min. cycles of endurance) be installed and be wired with C.E.C. Class I wiring.

D. INTERNAL WIRING

1. A diagram of the internal wiring of this unit is located on the inside of the electrical access panel. If any of the original wire, as supplied with the appliance must be replaced, the wire gauge and insulation must be the same as original wiring.

E. THERMOSTAT

The thermostat should be mounted on an inside wall about five feet above the floor in a location where it will not be affected by unconditioned air, sun, or drafts from open doors or other sources. READ installation instructions in heat pump thermostat package CAREFULLY because each has some different wiring requirements.

FIGURE 17

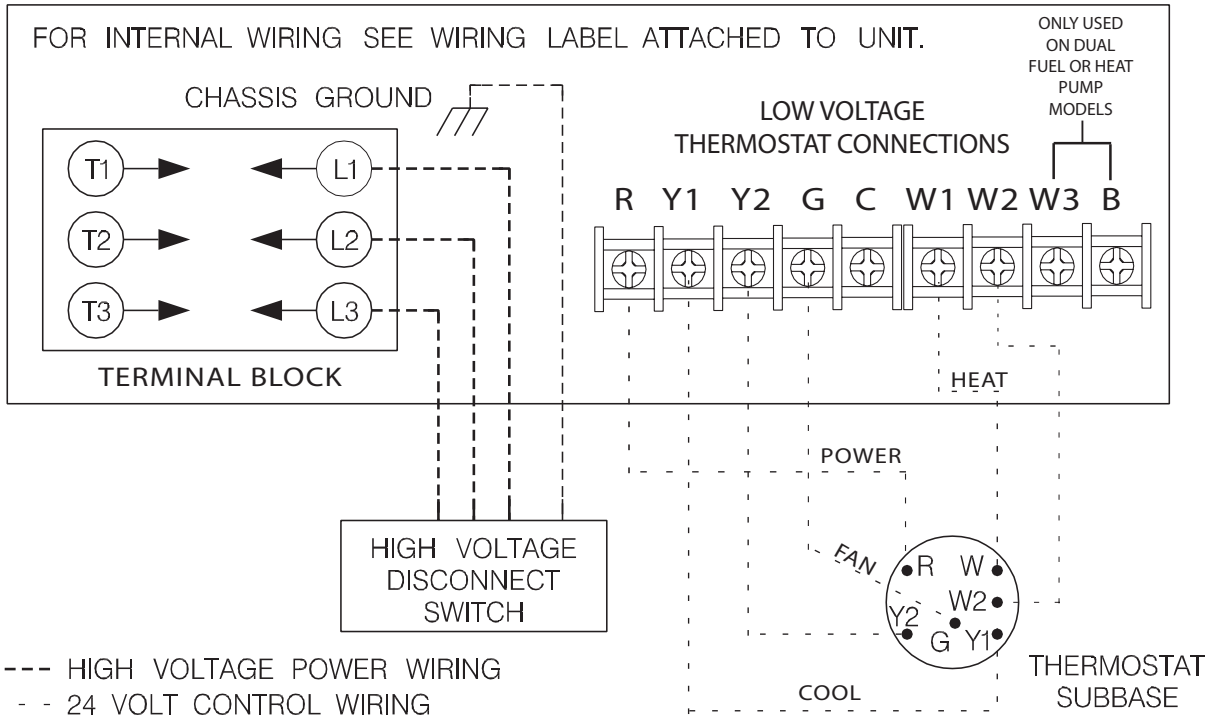

ST-A1125-12-00

XI. INDOOR AIR FLOW DATA

Belt-drive blower models have motor sheaves set for proper CFM at a typical external static. See airflow tables for blower performance.

XII. CRANKCASE HEAT (OPTIONAL)

Crankcase heat is not required on scroll type compressors, but may be desirable under certain conditions. Wires have been provided for the addition of crankcase heaters (see wiring diagrams).

FIGURE 18

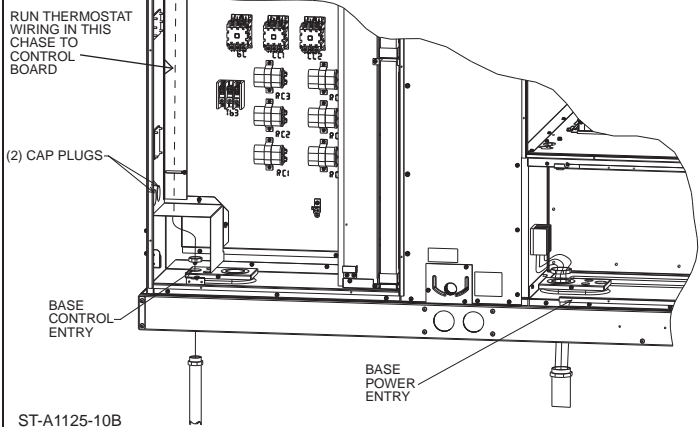

ST-A1125-10B

FIGURE 19

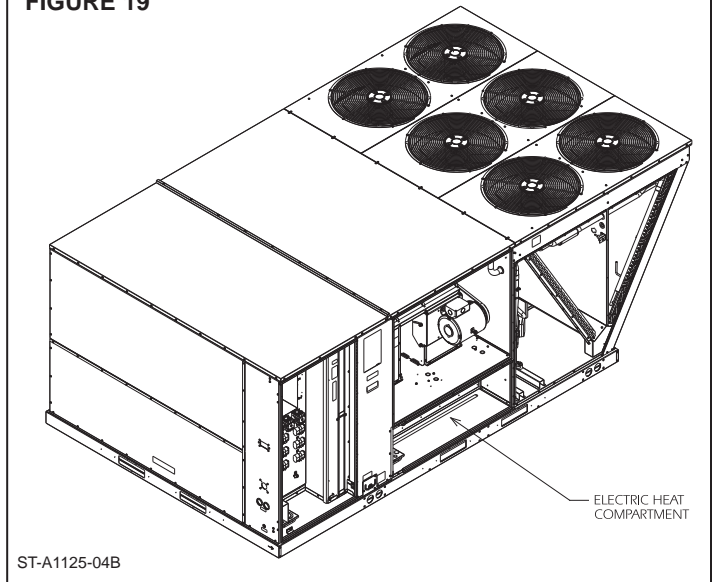

ST-A1125-04B

AIRFLOW PERFORMANCE — 15 TON [52.7kW] — SIDEFLOW

15 Ton
Voltage 208/230, 460, 575 — 3 phase

External Static Pressure — Inches of Water [kPa]

Air Flow CFM [L/s]	0.1 [0.2]		0.2 [0.5]		0.3 [0.7]		0.4 [1.0]		0.5 [1.2]		0.6 [1.5]		0.7 [1.7]		0.8 [2.0]		0.9 [2.2]		1.0 [2.5]		1.1 [2.7]		1.2 [3.0]		1.3 [3.2]		1.4 [3.5]		1.5 [3.7]		1.6 [4.0]		1.7 [4.2]		1.8 [4.5]		1.9 [4.7]		2.0 [5.0]					
	RPM	W	RPM	W	RPM	W	RPM	W	RPM	W	RPM	W	RPM	W	RPM	W	RPM	W	RPM	W	RPM	W	RPM	W	RPM	W	RPM	W	RPM	W	RPM	W	RPM	W	RPM	W	RPM	W	RPM	W	RPM	W	RPM	W
4800 [2265]	—	—	—	—	—	—	—	—	583	1393	608	1508	632	1621	656	1732	679	1841	701	1947	723	2052	744	2154	764	2254	785	2326	805	2430	825	2537	844	2647	863	2761	881	2878	899	2995				
5000 [2359]	—	—	—	—	—	—	—	—	591	1476	616	1593	640	1707	663	1820	686	1930	708	2038	729	2145	750	2248	771	2350	791	2420	811	2528	830	2640	850	2755	868	2873	887	2995	905	3118	924	3244	942	3384
5200 [2454]	—	—	—	—	—	—	—	—	575	1442	600	1562	624	1681	648	1797	671	1911	693	2023	715	2133	736	2241	757	2346	777	2410	797	2520	817	2633	836	2749	855	2869	874	2992	892	3118	910	3248	928	3384
5400 [2548]	—	—	—	—	—	—	—	—	583	1530	608	1652	632	1772	655	1890	678	2005	701	2119	722	2231	743	2340	764	2447	784	2512	804	2626	823	2744	842	2865	861	2989	879	3117	897	3248	914	3384		
5600 [2643]	—	—	—	—	—	—	—	—	592	1621	616	1745	640	1866	663	1986	686	2103	708	2218	729	2331	750	2442	770	2551	791	2620	810	2739	830	2861	849	2987	867	3116	885	3248	903	3384				
5800 [2737]	—	—	—	—	—	—	—	—	576	1588	601	1715	625	1840	649	1964	672	2085	694	2204	716	2321	737	2436	757	2548	778	2614	798	2735	817	2858	836	2985	855	3116	873	3249	891	3386	909	3527		
6000 [2831]	—	—	—	—	—	—	—	—	585	1683	610	1813	634	1940	657	2065	680	2187	702	2308	724	2426	744	2543	765	2657	785	2731	805	2856	824	2984	843	3116	861	3251	879	3389	897	3531	914	3676		
6200 [2926]	—	—	—	—	—	—	—	—	570	1650	595	1783	619	1913	643	2042	666	2169	688	2293	710	2415	731	2535	752	2653	773	2728	792	2854	811	2984	831	3116	850	3253	868	3392	886	3535	903	3682	920	3832
6400 [3020]	—	—	—	—	—	—	—	—	579	1750	604	1885	628	2017	652	2148	674	2276	697	2402	718	2526	739	2648	760	2767	780	2852	800	2983	819	3118	838	3255	856	3396	875	3541	892	3688	909	3839	926	3994
6600 [3114]	—	—	—	—	—	—	—	—	589	1854	614	1991	637	2125	661	2257	683	2386	705	2514	727	2640	748	2763	768	2884	788	2984	808	3119	827	3258	845	3400	863	3546	881	3695	899	3847	916	4003		
6800 [3209]	—	—	—	—	—	—	—	—	574	1822	599	1961	623	2099	647	2235	670	2369	692	2500	714	2629	735	2756	756	2882	776	2984	796	3121	815	3262	834	3405	853	3552	871	3702	888	3856	905	4013	922	4173
7000 [3303]	—	—	—	—	—	—	—	—	584	1930	609	2072	633	2211	656	2349	679	2484	701	2617	723	2748	744	2877	764	3003	785	3124	804	3265	823	3410	842	3559	860	3710	878	3865	895	4024	912	4185	929	4350
7200 [3398]	570	1887	595	2042	619	2185	643	2327	666	2466	689	2602	711	2737	732	2870	753	3000	773	3127	793	3270	812	3416	831	3566	849	3719	868	3875	885	4035	902	4198	919	4364	—	—	—	—	—	—		

NOTE: L-Drive left of bold line, M-Drive right of bold line.

Drive Package	L/R				M/S							
Motor H.P. [W]	3 [2237.1]				5 [3728.5]							
Blower Sheave	BK105H				BK105H							
Motor Sheave	1VL-44				1VP-56							
Turns Open	1	2	3	4	5	6	1	2	3	4	5	6
RPM	733	701	669	640	605	572	927	903	873	840	808	775

- NOTES: 1. Factory sheave settings are shown in bold type.
 2. Do not set motor sheave below minimum turns open shown.
 3. Re-adjustment of sheave required to achieve rated airflow at ARI minimum External Static Pressure
 4. Drive data shown is for horizontal airflow with dry coil. Add component resistance (below) to duct resistance to determine total External Static Pressure.

COMPONENT AIRFLOW RESISTANCE — 15 TON [52.7kW]

CFM [L/s]	Resistance — Inches of Water [kPa]										
	4800 [2265]	5000 [2359]	5200 [2454]	5400 [2548]	5600 [2643]	5800 [2737]	6000 [2831]	6200 [2926]	6400 [3020]	6600 [3114]	7200 [3398]
Wet Coil	0.03 [0.01]	0.04 [0.01]	0.05 [0.01]	0.06 [0.01]	0.06 [0.01]	0.07 [0.02]	0.08 [0.02]	0.09 [0.02]	0.10 [0.02]	0.10 [0.02]	0.13 [0.03]
Downflow	0.05 [0.01]	0.05 [0.01]	0.05 [0.01]	0.05 [0.01]	0.05 [0.01]	0.05 [0.01]	0.05 [0.01]	0.06 [0.01]	0.06 [0.01]	0.06 [0.01]	0.08 [0.02]
Downflow Economizer RA Damper Open	0.09 [0.02]	0.10 [0.02]	0.10 [0.02]	0.11 [0.03]	0.12 [0.03]	0.13 [0.03]	0.14 [0.03]	0.14 [0.04]	0.15 [0.04]	0.16 [0.04]	0.18 [0.04]
Horizontal Economizer RA Damper Open	0.00 [0.00]	0.01 [0.00]	0.01 [0.00]	0.02 [0.00]	0.02 [0.00]	0.03 [0.00]	0.04 [0.01]	0.04 [0.01]	0.05 [0.01]	0.05 [0.01]	0.06 [0.01]
Concentric Grill RXRN-AD80 or RXRN-AD81 & Transition RXMC-CJ07	0.21 [0.05]	0.25 [0.06]	0.28 [0.07]	0.32 [0.08]	0.35 [0.09]	0.43 [0.10]	0.46 [0.11]	0.46 [0.11]	0.50 [0.12]	0.54 [0.13]	0.64 [0.15]

AIRFLOW CORRECTION FACTORS — 15 TON [52.7kW]

CFM	4800	5000	5200	5400	5600	5800	6000	6200	6400	6600	6800	7000	7200
[L/s]	[2265]	[2359]	[2454]	[2548]	[2643]	[2737]	[2831]	[2926]	[3020]	[3114]	[3209]	[3303]	[3398]
Total MBH	0.97	0.97	0.98	0.98	0.99	1.00	1.00	1.01	1.02	1.02	1.03	1.03	1.04
Sensible MBH	0.87	0.90	0.92	0.94	0.97	0.99	1.02	1.04	1.06	1.09	1.11	1.14	1.16
Power kW	0.98	0.98	0.99	0.99	1.00	1.00	1.00	1.00	1.01	1.01	1.01	1.02	1.02

NOTE: Multiply correction factor times gross performance data — resulting sensible capacity cannot exceed total capacity.

[] Designates Metric Conversions

XIII. PRE-START CHECK

1. Is unit properly located and slightly slanted toward indoor condensate drain?
2. Is ductwork insulated, weatherproofed, with proper spacing to combustible materials?
3. Is air free to travel to and from outdoor coil? (See Figure 5.)
4. Is the wiring correct, tight, and according to unit wiring diagram?
5. Is unit grounded?
6. Are field supplied air filters in place and clean?
7. Do the outdoor fan and indoor blower turn freely without rubbing, and are they tight on the motor shafts?

XIV. STARTUP

1. Turn thermostat to "OFF," turn "on" power supply at disconnect switch.
2. Turn temperature setting as high as it will go.
3. Turn fan switch to "ON."
4. Indoor blower should run. Be sure it is running in the right direction.
5. Turn fan switch to "AUTO." Turn system switch to "COOL" and turn temperature setting below room temperature. Unit should run in cooling mode.
6. Is outdoor fan operating correctly in the right direction?
7. Is compressor running correctly.

Record the following after the unit has run some time.

- A. Operating Mode _____
- B. Discharge Pressures (High) _____ PSIG
- C. Vapor Pressure at Compressors (Low) _____ PSIG
- D. Vapor Line Temperature at Compressors °F.
- E. Indoor Dry Bulb _____ °F.
- F. Indoor Wet Bulb _____ °F.
- G. Outdoor Dry Bulb _____ °F.
- H. Outdoor Wet Bulb _____ °F.
- I. Voltage at Contactor _____ Volts
- J. Current at Contactors _____ Amps
- K. Model Number _____
- L. Serial Number _____
- M. Location _____
- N. Owner _____
- O. Date _____

8. Turn thermostat system switch to "HEAT." Unit compressors should stop. Raise temperature setting to above room temperature. Unit should run in heating mode and auxiliary heaters, if installed, should come on.
9. Check the refrigerant charge using the instructions located on unit charging chart. Replace service port caps. Service port cores are for system access only and will leak if not tightly capped.
10. Adjust discharge air grilles and balance system.
11. Check ducts for condensation and air leaks.
12. Check unit for tubing and sheet metal rattles.
13. Instruct the owner on operation and maintenance.
14. Leave "INSTALLATION" and "USE AND CARE" instructions with owner.

XV. OPERATION

COOLING MODE

With thermostat in the cool mode, fan auto and the room temperature higher than the thermostat setting:

- A. Indoor blower contactor is energized through thermostat contact (G).
- B. Compressor contactors are energized through thermostat contacts (Y1) & (Y2) and pressure controls.
- C. Economizer enthalpy control (if installed) controls operation of first-stage cooling and positions fresh air damper to maintain mixed air temperature. Second-stage cooling operates normally as required by second stage of thermostats.
- D. The system will continue in cooling operation as long as all safety controls are closed, until the thermostat is satisfied.

HEATING MODE

With thermostat in the heat mode, fan auto and the room temperature lower than the thermostat setting the indoor blower contactor is energized through thermostat contact (G).

▲ WARNING

ONLY ELECTRIC HEATER KITS SUPPLIED BY THIS MANUFACTURER AS DESCRIBED IN THIS PUBLICATION HAVE BEEN DESIGNED, TESTED, AND EVALUATED BY A NATIONALLY RECOGNIZED SAFETY TESTING AGENCY FOR USE WITH THIS UNIT. USE OF ANY OTHER MANUFACTURED ELECTRIC HEATERS INSTALLED WITHIN THIS UNIT MAY CAUSE HAZARDOUS CONDITIONS RESULTING IN PROPERTY DAMAGE, FIRE, BODILY INJURY OR DEATH.

XVI. UNITS WITH A BLOWER VFD

No adjustments of the VFD are required for installation or operation of this unit.

VFD MODEL

Schneider Altivar 212 (factory programmed).

REPLACEMENT

The VFD is horsepower and voltage specific therefore; replacement must be the same model as the existing. A preprogrammed VFD is recommended and available from ProStock. A non-programmed Schneider Altivar 212 may be used but must be programmed exactly per the included VFD I & O Manual (92-104334-01) programming guide for safe and proper function.

OPERATION

The purpose of the VFD is to allow low airflow in Fan Only (G) and First Stage Cooling (Y1) operation of a two stage unit. Unit air balancing should be performed at 100% airflow (60Hz at VFD) during a W1, W2 or Y2 call by adjusting the blower motor sheave. To meet ASHRAE 90.1-2010 and for best performance, First Stage Cool and Fan Only speeds are factory set at 50% airflow (30 Hz at VFD). Both of these speeds are independently adjustable at the RTU-C. The VFD display will indicate an equivalent value in Hz (ie. Low Cool adjusted to 60% at RTU-C will display as 36Hz at the VFD). A 20 second (adjustable at the VFD) ramp-up or ramp-down is used whenever the blower speed is increased or decreased. Low speed blower operation first ramps to 75%, to close fan proving switch, before ramping to the desired speed. Since the VFD operates on 24VDC control voltage, a blower relay (with 24VAC across the coil) is used to turn the VFD on. Blower speeds are changed via Modbus communication from the RTU-C. For more information see VFD I & O Manual (92-104334-01).

XVII. AUXILIARY HEAT

In the heating mode, the thermostat will energize one or more supplementary resistance heaters.

REPLACEMENT PARTS

Contact your local distributor for a complete parts list.

CHARGE INFORMATION

Refer to the appropriate charge chart on the unit, or in this booklet.

TROUBLESHOOTING

Refer to the troubleshooting chart included in this manual.

WIRING DIAGRAMS

Refer to the appropriate wiring diagram included in this manual.

XVIII. HEATER KIT CHARACTERISTICS
TABLE G. AUXILIARY HEATER KITS CHARACTERISTICS AND APPLICATION
(15, 17.5, 20 & 25 TON MODELS)

208/240 VOLT, THREE PHASE, 60 HZ, AUXILIARY ELECTRIC HEATER KITS CHARACTERISTICS AND APPLICATION												
Single Power Supply For Both Unit And Heater Kit												
Unit Model Number RLNL-	Heater Kit					Air Conditioner			Separate Power Supply For Both Unit And Heater Kit			
	RXJJ- Heater Kit Nominal kW	No. of Sequence Steps	Rated Heater kW @ 208/240 V	Heater KBTU/Hr @ 208/240 V	Heater Amp. @ 208/240 V	Unit Min. Ckt Ampacity @ 208/240 V	Over Current Protective Device Size Min./Max. @ 208 V	Min. Ckt Ampacity 208/240V	Max. Fuse Size 208/240V	Min. Ckt Ampacity 208/240V	Over Current Protective Device Size Min./Max. @ 208 V	Min./Max. @ 240 V
No Heat	—	—	—	—	—	78/78	90/100	78/78	—	78/78	90/100	90/100
B180CL/ C180CL/ H180CR	CE20C CE40C CE60C CE75C	1 2 2 2	14.4/19.2 28.8/38.3 43.2/57.5 54/71.9	49.13/65.5 98.25/130.66 147.38/196.1 184.22/245.2	40/46.2 79.9/92.2 119.9/138.3 149.8/172.8	78/78 115/130 165/188 202/231	90/100 125/125 175/175 225/225	78/78 100/116 150/173 188/217	50/58 100/116 150/173 200/225	78/78	90/100	90/100
No Heat	—	—	—	—	—	88/88	110/110	88/88	—	88/88	110/110	110/110
B210CL/ C210CL/ H210CR	CE20C CE40C CE60C CE75C	1 2 2 2	14.4/19.2 28.8/38.3 43.2/57.5 54/71.9	49.13/65.5 98.25/130.66 147.38/196.1 184.22/245.2	40/46.2 79.9/92.2 119.9/138.3 149.8/172.8	88/88 115/130 165/188 202/231	110/110 125/125 175/175 225/225	88/88 100/116 150/173 188/217	50/58 100/116 150/173 200/225	88/88	110/110	110/110
No Heat	—	—	—	—	—	101/101	110/125	101/101	—	101/101	110/125	110/125
B240CL/ C240CL/ H240CR	CE20C CE40C CE60C CE75C	1 2 2 2	14.4/19.2 28.8/38.3 43.2/57.5 54/71.9	49.13/65.5 98.25/130.66 147.38/196.1 184.22/245.2	40/46.2 79.9/92.2 119.9/138.3 149.8/172.8	101/101 119/134 169/192 206/235	110/125 125/125 175/175 225/225	101/101 100/116 150/173 188/217	50/58 100/116 150/173 200/225	101/101	110/125	110/125
No Heat	—	—	—	—	—	147/147	175/175	147/147	—	147/147	175/175	175/175
B300CL/ C300CL/ H300CR	CE20C CE40C CE60C CE75C	1 2 2 2	14.4/19.2 28.8/38.3 43.2/57.5 54/71.9	49.13/65.5 98.25/130.66 147.38/196.1 184.22/245.2	40/46.2 79.9/92.2 119.9/138.3 149.8/172.8	147/147 181/204 218/247	175/175 200/200 225/225	147/147 150/173 188/217	50/58 100/116 150/173 200/225	147/147	175/175	175/175

XVIII. HEATER KIT CHARACTERISTICS
TABLE G. AUXILIARY HEATER KITS CHARACTERISTICS AND APPLICATION
(15, 17.5, 20 & 25 TON MODELS)

208/240 VOLT, THREE PHASE, 60 HZ, AUXILIARY ELECTRIC HEATER KITS CHARACTERISTICS AND APPLICATION													
Separate Power Supply For Both Unit And Heater Kit													
Unit Model Number RLNL-	Single Power Supply For Both Unit And Heater Kit						Heater Kit						
	RXJJ-Heater Kit Nominal kW	No. of Sequence Steps	Rated Heater kW @ 208/240 V	Heater KBTU/Hr @ 208/240 V	Heater Amp. @ 208/240 V	Unit Min. Ckt Ampacity @ 208/240 V	Over Current Protective Device Size Min./Max. @ 208 V	Over Current Protective Device Size Min./Max. @ 240 V	Min. Ckt Ampacity 208/240V	Max. Fuse Size 208/240V	Min. Ckt. Ampacity 208/240V	Over Current Protective Device Size Min./Max. @ 208 V	Over Current Protective Device Size Min./Max. @ 240 V
B180CM/	No Heat	—	—	—	—	81/81	90/100	90/100	81/81	—	—	90/100	90/100
C180CM/	CE20C	1	14.4/19.2	49.13/65.5	40/46.2	81/81	90/100	90/100	50/58	50/60	—	—	—
H180CS	CE40C	2	28.8/38.3	98.25/130.66	79.9/92.2	119/134	125/125	150/150	100/116	100/125	—	—	—
	CE60C	2	43.2/57.5	147.38/196.1	119.9/138.3	169/192	175/175	200/200	150/173	150/175	—	—	—
	CE75C	2	54/71.9	184.22/245.2	149.8/172.8	206/235	225/225	250/250	188/217	200/225	—	—	—
B210CM/	NONE	—	—	—	—	91/91	100/110	100/110	—	—	110/110	—	—
C210CM/	CE20C	1	14.4/19.2	49.13/65.5	40/46.2	91/91	100/110	100/110	50/58	50/60	—	—	—
H210CS	CE40C	2	28.8/38.3	98.25/130.66	79.9/92.2	119/134	125/125	150/150	100/116	100/125	—	—	—
	CE60C	2	43.2/57.5	147.38/196.1	119.9/138.3	169/192	175/175	200/200	150/173	150/175	—	—	—
	CE75C	2	54/71.9	184.22/245.2	149.8/172.8	206/235	225/225	250/250	188/217	200/225	—	—	—
B240CM/	No Heat	—	—	—	—	109/109	125/125	125/125	—	—	109/109	125/125	125/125
C240CM/	CE20C	1	14.4/19.2	49.13/65.5	40/46.2	109/109	125/125	125/125	50/58	50/60	—	—	—
H240CS	CE40C	2	28.8/38.3	98.25/130.66	79.9/92.2	129/145	150/150	150/150	100/116	100/125	—	—	—
	CE60C	2	43.2/57.5	147.38/196.1	119.9/138.3	179/202	200/200	225/225	150/173	150/175	—	—	—
	CE75C	2	54/71.9	184.22/245.2	149.8/172.8	217/245	225/225	250/250	188/217	200/225	—	—	—
B300CM/	No Heat	—	—	—	—	149/149	175/175	175/175	—	—	149/149	175/175	175/175
C300CM/	CE20C	1	14.4/19.2	49.13/65.5	40/46.2	149/149	175/175	175/175	50/58	50/60	—	—	—
H300CS	CE40C	2	28.8/38.3	98.25/130.66	79.9/92.2	149/151	175/175	175/175	100/116	100/125	—	—	—
	CE60C	2	43.2/57.5	147.38/196.1	119.9/138.3	186/209	200/200	225/225	150/173	150/175	—	—	—
	CE75C	2	54/71.9	184.22/245.2	149.8/172.8	223/252	225/225	300/300	188/217	200/225	—	—	—

XVIII. HEATER KIT CHARACTERISTICS

TABLE G (CONTINUED). AUXILIARY HEATER KITS CHARACTERISTICS AND APPLICATION (15, 20 & 25 TON MODELS)

208/240 VOLT, THREE PHASE, 60 HZ, AUXILIARY ELECTRIC HEATER KITS CHARACTERISTICS AND APPLICATION												
Single Power Supply For Both Unit And Heater Kit						Separate Power Supply For Both Unit And Heater Kit						
Unit Model Number RLNL-	Heater Kit			Air Conditioner			Heater Kit			Air Conditioner		
	RXJJ-Heater Kit Nominal kW	No. of Sequence Steps	Rated Heater kW @ 208/240 V	Heater KBTU/Hr @ 208/240 V	Heater Amp. @ 208/240 V	Unit Min. Ckt Ampacity @ 208/240 V	Over Current Protective Device Size		Min. Ckt Ampacity 208/240V	Max. Fuse Size 208/240V	Over Current Protective Device Size	
							Min./Max. @ 208 V	Min./Max. @ 240 V			Min./Max. @ 208 V	Min./Max. @ 240 V
No Heat	—	—	—	—	—	109/109	125/125	125/125	—	—	109/109	125/125
B240CN/	CE20C	1	14.4/19.2	49.13/65.5	40/46.2	109/109	125/125	125/125	50/58	50/60	—	—
C240CN/	CE40C	2	28.8/38.3	98.25/130.66	79.9/92.2	129/145	150/150	150/150	100/116	100/125	—	—
H240CT	CE60C	2	43.2/57.5	147.38/196.1	119.9/138.3	179/202	200/200	225/225	150/173	150/175	—	—
	CE75C	2	54/71.9	184.22/245.2	149.8/172.8	217/245	225/225	250/250	188/217	200/225	—	—

480 VOLT, THREE PHASE, 60 HZ, AUXILIARY ELECTRIC HEATER KITS CHARACTERISTICS AND APPLICATION												
Single Power Supply For Both Unit And Heater Kit						Separate Power Supply For Both Unit And Heater Kit						
Unit Model Number RLNL-	Heater Kit			Air Conditioner			Heater Kit			Air Conditioner		
	RXJJ-Heater Kit Nominal kW	No. of Sequence Steps	Rated Heater kW @ 480 V	Heater KBTU/Hr @ 480 V	Heater Amp. @ 480 V	Unit Min. Ckt Ampacity @ 480 V	Over Current Protective Device Size		Min. Ckt Ampacity 480V	Max. Fuse Size 480V	Over Current Protective Device Size	
							Min./Max. @ 480 V	Min./Max. @ 480 V			Min./Max. @ 480 V	Min./Max. @ 480 V
No Heat	—	—	—	—	—	38	45/45	—	—	—	38	45/45
B180DL/	CE20D	1	19.2	65.5	23.1	38	45/45	—	29	30	—	—
C180DL/	CE40D	2	38.4	131	46.2	64	70/70	—	58	60	—	—
H180DR	CE60D	2	57.6	196.5	69.3	93	100/100	—	87	90	—	—
	CE75D	2	72	245.63	86.6	114	125/125	—	109	110	—	—
NONE	—	—	—	—	—	44	50/50	—	—	—	44	50
B210DL/	CE20D	1	19.2	65.5	23.1	44	50/50	—	29	30	—	—
C210DL/	CE40D	2	38.4	131	46.2	64	70/70	—	58	60	—	—
H210DR	CE60D	2	57.6	196.5	69.3	93	100/100	—	87	90	—	—
	CE75D	2	72	245.63	86.6	114	125/125	—	109	110	—	—
No Heat	—	—	—	—	—	52	60/60	—	—	—	52	60/60
B240DL/	CE20D	1	19.2	65.5	23.1	52	60/60	—	29	30	—	—
C240DL/	CE40D	2	38.4	131	46.2	67	70/70	—	58	60	—	—
H240DR	CE60D	2	57.6	196.5	69.3	95	100/100	—	87	90	—	—
	CE75D	2	72	245.63	86.6	117	125/125	—	109	110	—	—
No Heat	—	—	—	—	—	60	70/70	—	—	—	60	70/70
B300DL/	CE20D	1	19.2	65.5	23.1	60	70/70	—	29	30	—	—
C300DL/	CE40D	2	38.4	131	46.2	70	70/70	—	58	60	—	—
H300DR	CE60D	2	57.6	196.5	69.3	99	100/100	—	87	90	—	—
	CE75D	2	72	245.63	86.6	121	125/125	—	109	110	—	—

XVIII. HEATER KIT CHARACTERISTICS

TABLE G (CONTINUED). AUXILIARY HEATER KITS CHARACTERISTICS AND APPLICATION (15, 20 & 25 TON MODELS)

480 VOLT, THREE PHASE, 60 HZ, AUXILIARY ELECTRIC HEATER KITS CHARACTERISTICS AND APPLICATION													
Single Power Supply For Both Unit And Heater Kit													
Unit Model Number RLNL-	Heater Kit				Air Conditioner				Heater Kit				Air Conditioner
	RXJJ-Heater Kit Nominal kW	No. of Sequence Steps	Rated Heater kW @ 480 V	Heater KBTU/Hr @ 480 V	Heater Amp. @ 480 V	Unit Min. Ckt Ampacity @ 480 V	Over Current Protective Device Size Min./Max. @ 480 V	Min. Ckt. Ampacity 480V	Max. Fuse Size 480V	Min. Circuit Ampacity 480V	Over Current Protective Device Size Min./Max. @ 480 V		
B180DM/	No Heat	—	—	—	—	40	45/50	—	—	40	45/50	—	
C180DM/	CE20D	1	19.2	65.5	23.1	40	45/50	—	30	—	—	—	
H180DS	CE40D	2	38.4	131	46.2	67	70/70	—	60	—	—	—	
	CE60D	2	57.6	196.5	69.3	95	100/100	—	90	—	—	—	
	CE75D	2	72	245.63	86.6	117	125/125	—	110	—	—	—	
B210DM/	No Heat	—	—	—	—	46	50/50	—	—	46	50	—	
C210DM/	CE20D	—	19.2	65.5	23.1	44	50/50	—	30	—	—	—	
H210DS	CE40D	—	38.4	131	46.2	67	70/70	—	60	—	—	—	
	CE60D	—	57.6	196.5	69.3	95	100/100	—	90	—	—	—	
	CE75D	—	72	245.63	86.6	117	125/125	—	110	—	—	—	
B240DM/	No Heat	—	—	—	—	56	60/70	—	—	56	60/70	—	
C240DM/	CE20D	1	19.2	65.5	23.1	56	60/70	—	30	—	—	—	
H240DS	CE40D	2	38.4	131	46.2	70	70/70	—	60	—	—	—	
	CE60D	2	57.6	196.5	69.3	99	100/100	—	90	—	—	—	
	CE75D	2	72	245.63	86.6	121	125/125	—	110	—	—	—	
B300DM/	No Heat	—	—	—	—	63	70/80	—	—	63	70/80	—	
C300DM/	CE20D	1	19.2	65.5	23.1	63	70/80	—	30	—	—	—	
H300DS	CE40D	2	38.4	131	46.2	74	80/80	—	60	—	—	—	
	CE60D	2	57.6	196.5	69.3	103	110/110	—	90	—	—	—	
	CE75D	2	72	245.63	86.6	124	125/125	—	110	—	—	—	

480 VOLT, THREE PHASE, 60 HZ, AUXILIARY ELECTRIC HEATER KITS CHARACTERISTICS AND APPLICATION													
Single Power Supply For Both Unit And Heater Kit													
Unit Model Number RLNL-	Heater Kit				Air Conditioner				Heater Kit				Air Conditioner
	RXJJ-Heater Kit Nominal kW	No. of Sequence Steps	Rated Heater kW @ 480 V	Heater KBTU/Hr @ 480 V	Heater Amp. @ 480 V	Unit Min. Ckt Ampacity @ 480 V	Over Current Protective Device Size Min./Max. @ 480 V	Min. Ckt. Ampacity 480V	Max. Fuse Size 480V	Min. Circuit Ampacity 480V	Over Current Protective Device Size Min./Max. @ 480 V		
B240DN/	No Heat	—	—	—	—	56	60/70	—	—	56	60/70	—	
C240DN/	CE20D	1	19.2	65.5	23.1	56	60/70	—	30	—	—	—	
H240DT	CE40D	2	38.4	131	46.2	70	70/70	—	60	—	—	—	
	CE60D	2	57.6	196.5	69.3	99	100/100	—	90	—	—	—	
	CE75D	2	72	245.63	86.6	121	125/125	—	110	—	—	—	

XVIII. HEATER KIT CHARACTERISTICS

TABLE G (CONTINUED). AUXILIARY HEATER KITS CHARACTERISTICS AND APPLICATION (15, 20 & 25 TON MODELS)

600 VOLT, THREE PHASE, 60 HZ, AUXILIARY ELECTRIC HEATER KITS CHARACTERISTICS AND APPLICATION													
Separate Power Supply For Both Unit And Heater Kit													
Unit Model Number RLNL-	Single Power Supply For Both Unit And Heater Kit					Air Conditioner				Heater Kit			
	RXJJ- Heater Kit Nominal kW	No. of Sequence Steps	Rated Heater kW @ 600 V	Heater KBTU/Hr @ 600 V	Heater Amp. @ 600 V	Unit Min. Ckt Ampacity @ 600 V	Over Current Protective Device Size Min./Max. @ 600 V	Over Current Protective Device Size Min./Max. @ 600 V	Min. Ckt Ampacity 600V	Max. Fuse Size 600V	Min. Ckt Ampacity 600V	Over Current Protective Device Size Min./Max. @ 600 V	Over Current Protective Device Size Min./Max. @ 600 V
B180YL/ C180YL	No Heat	—	—	—	—	28	30/35	30/35	28	—	28	30/35	—
	CE20Y	1	19.2	65.5	18.5	28	30/35	30/35	—	25	—	—	—
	CE40Y	2	38.4	131	37	51	60/60	60/60	47	50	—	—	—
	CE60Y	2	57.6	196.5	55.4	74	80/80	80/80	70	70	—	—	—
	CE75Y	2	72	245.63	69.3	92	100/100	100/100	87	90	—	—	—
B210YL/ C210YL	No Heat	—	—	—	—	35	45/45	45/45	35	—	35	45	—
	CE20Y	—	19.2	65.5	18.5	35	45/45	45/45	—	25	—	—	—
	CE40Y	—	38.4	131	37	51	60/60	60/60	47	50	—	—	—
	CE60Y	—	57.6	196.5	55.4	74	80/80	80/80	70	70	—	—	—
	CE75Y	—	72	245.63	69.3	92	100/100	100/100	87	90	—	—	—
B240YL/ C240YL	No Heat	—	—	—	—	40	45/50	45/50	40	—	40	45/50	—
	CE20Y	1	19.2	65.5	18.5	40	45/50	45/50	—	25	—	—	—
	CE40Y	2	38.4	131	37	53	60/60	60/60	47	50	—	—	—
	CE60Y	2	57.6	196.5	55.4	76	80/80	80/80	70	70	—	—	—
	CE75Y	2	72	245.63	69.3	94	100/100	100/100	87	90	—	—	—
B300YL/ C300YL	No Heat	—	—	—	—	47	60/60	60/60	47	—	47	60/60	—
	CE20Y	1	19.2	65.5	18.5	47	60/60	60/60	—	25	—	—	—
	CE40Y	2	38.4	131	37	56	60/60	60/60	47	50	—	—	—
	CE60Y	2	57.6	196.5	55.4	80	80/80	80/80	70	70	—	—	—
	CE75Y	2	72	245.63	69.3	97	100/100	100/100	87	90	—	—	—

XVIII. HEATER KIT CHARACTERISTICS

TABLE G (CONTINUED). AUXILIARY HEATER KITS CHARACTERISTICS AND APPLICATION (15, 20 & 25 TON MODELS)

600 VOLT, THREE PHASE, 60 HZ, AUXILIARY ELECTRIC HEATER KITS CHARACTERISTICS AND APPLICATION													
Single Power Supply For Both Unit And Heater Kit						Separate Power Supply For Both Unit And Heater Kit							
Unit Model Number RLNL-	Heater Kit					Air Conditioner			Heater Kit			Air Conditioner	
	RXJJ-Heater Kit Nominal kW	No. of Sequence Steps	Rated Heater kW @ 600 V	Heater KBTU/Hr @ 600 V	Heater Amp. @ 600 V	Unit Min. Ckt Ampacity @ 600 V	Over Current Protective Device Size		Min. Ckt. Ampacity 600V	Max. Fuse Size 600V	Min. Circuit Ampacity 600V	Over Current Protective Device Size	
							Min./Max. @ 600 V	Min./Max. @ 600 V				Min./Max. @ 600 V	Min./Max. @ 600 V
B180YM/ C180YM	No Heat	—	—	—	—	30	35/35	35/35	—	—	30	35/35	—
	CE20Y	1	19.2	65.5	18.5	30	35/35	—	24	25	—	—	—
	CE40Y	2	38.4	131	37	53	60/60	—	47	50	—	—	—
	CE60Y	2	57.6	196.5	55.4	76	80/80	—	70	70	—	—	—
	CE75Y	2	72	245.63	69.3	94	100/100	—	87	90	—	—	—
B210YM/ C210YM	No Heat	—	—	—	—	37	40/45	40/45	—	—	37	45	—
	CE20Y	—	19.2	65.5	18.5	37	40/45	—	24	25	—	—	—
	CE40Y	—	38.4	131	37	53	60/60	—	47	50	—	—	—
	CE60Y	—	57.6	196.5	55.4	76	80/80	—	70	70	—	—	—
	CE75Y	—	72	245.63	69.3	94	100/100	—	87	90	—	—	—
B240YM/ C240YM	No Heat	—	—	—	—	42	50/50	50/50	—	—	42	50/50	—
	CE20Y	1	19.2	65.5	18.5	42	50/50	—	24	25	—	—	—
	CE40Y	2	38.4	131	37	56	60/60	—	47	50	—	—	—
	CE60Y	2	57.6	196.5	55.4	80	80/80	—	70	70	—	—	—
	CE75Y	2	72	245.63	69.3	97	100/100	—	87	90	—	—	—
B300YM/ C300YM	No Heat	—	—	—	—	50	60/60	60/60	—	—	50	60/60	—
	CE20Y	1	19.2	65.5	18.5	50	60/60	—	24	25	—	—	—
	CE40Y	2	38.4	131	37	59	60/60	—	47	50	—	—	—
	CE60Y	2	57.6	196.5	55.4	82	90/90	—	70	70	—	—	—
	CE75Y	2	72	245.63	69.3	100	100/100	—	87	90	—	—	—

600 VOLT, THREE PHASE, 60 HZ, AUXILIARY ELECTRIC HEATER KITS CHARACTERISTICS AND APPLICATION													
Single Power Supply For Both Unit And Heater Kit						Separate Power Supply For Both Unit And Heater Kit							
Unit Model Number RLNL-	Heater Kit					Air Conditioner			Heater Kit			Air Conditioner	
	RXJJ-Heater Kit Nominal kW	No. of Sequence Steps	Rated Heater kW @ 600 V	Heater KBTU/Hr @ 600 V	Heater Amp. @ 600 V	Unit Min. Ckt Ampacity @ 600 V	Over Current Protective Device Size		Min. Ckt. Ampacity 600V	Max. Fuse Size 600V	Min. Circuit Ampacity 600V	Over Current Protective Device Size	
							Min./Max. @ 600 V	Min./Max. @ 600 V				Min./Max. @ 600 V	Min./Max. @ 600 V
B240YN/ C240YN	No Heat	—	—	—	—	42	50/50	50/50	—	—	42	50/50	—
	CE20Y	1	19.2	65.5	18.5	42	50/50	—	24	25	—	—	—
	CE40Y	2	38.4	131	37	56	60/60	—	47	50	—	—	—
	CE60Y	2	57.6	196.5	55.4	80	80/80	—	70	70	—	—	—
	CE75Y	2	72	245.63	69.3	97	100/100	—	87	90	—	—	—

TROUBLE SHOOTING CHART

▲ WARNING

DISCONNECT ALL POWER TO UNIT BEFORE SERVICING. CONTACTOR MAY BREAK ONLY ONE SIDE. FAILURE TO SHUT OFF POWER CAN CAUSE ELECTRICAL SHOCK RESULTING IN PERSONAL INJURY OR DEATH.

SYMPTOM	POSSIBLE CAUSE	REMEDY
Unit will not run	<ul style="list-style-type: none"> • Power off or loose electrical connection • Thermostat out of calibration-set too high • Defective contactor • Blown fuses • Transformer defective • High pressure control open (if provided) • Interconnecting low voltage wiring damaged 	<ul style="list-style-type: none"> • Check for correct voltage at compressor contactor in control box • Reset • Check for 24 volts at contactor coil - replace if contacts are open • Replace fuses • Check wiring-replace transformer • Reset-also see high head pressure remedy- • Replace thermostat wiring
Condenser fan runs, compressor doesn't	<ul style="list-style-type: none"> • Run capacitor defective (single phase only) • Loose connection • Compressor stuck, grounded or open motor winding open internal overload. • Low voltage condition 	<ul style="list-style-type: none"> • Replace • Check for correct voltage at compressor - check & tighten all connections • Wait at least 2 hours for overload to reset. If still open, replace the compressor. At compressor terminals, voltage must be within 10% of rating plate volts when unit is operating.
Insufficient cooling	<ul style="list-style-type: none"> • Improperly sized unit • Improper airflow • Incorrect refrigerant charge • Air, non-condensibles or moisture in system • Incorrect voltage 	<ul style="list-style-type: none"> • Recalculate load • Check - should be approximately 400 CFM per ton. • Charge per procedure attached to unit service panel. • Recover refrigerant, evacuate & recharge, add filter drier • At compressor terminals, voltage must be within 10% of rating plate volts when unit is operating.
Compressor short cycles	<ul style="list-style-type: none"> • Incorrect voltage • Defective overload protector • Refrigerant undercharge 	<ul style="list-style-type: none"> • At compressor terminals, voltage must be \pm 10% of nameplate marking when unit is operating. • Replace - check for correct voltage • Add refrigerant
Registers sweat	<ul style="list-style-type: none"> • Low evaporator airflow 	<ul style="list-style-type: none"> • Increase speed of blower or reduce restriction - replace air filter
High head-low vapor pressures	<ul style="list-style-type: none"> • Restriction in liquid line, expansion device or filter drier • TXV does not open 	<ul style="list-style-type: none"> • Remove or replace defective component • Replace TXV
High head-high or normal vapor pressure - Cooling mode	<ul style="list-style-type: none"> • Dirty condenser coil • Refrigerant overcharge • Condenser fan not running • Air or non-condensibles in system 	<ul style="list-style-type: none"> • Clean coil • Correct system charge • Repair or replace • Recover refrigerant, evacuate & recharge
Low head-high vapor pressures	<ul style="list-style-type: none"> • Defective Compressor valves 	<ul style="list-style-type: none"> • Replace compressor
Low vapor - cool compressor - iced evaporator coil	<ul style="list-style-type: none"> • Low evaporator airflow • Operating below 65°F outdoors • Moisture in system • Dirty evaporator coil, bent fins 	<ul style="list-style-type: none"> • Increase speed of blower or reduce restriction - replace air filter • Add Low Ambient Kit • Recover refrigerant - evacuate & recharge - add filter drier • Clean evaporator coil, straighten fins
High vapor pressure	<ul style="list-style-type: none"> • Excessive load • Defective compressor 	<ul style="list-style-type: none"> • Recheck load calculation • Replace
Fluctuating head & vapor pressures	<ul style="list-style-type: none"> • TXV hunting • Air or non-condensibles in system 	<ul style="list-style-type: none"> • Check TXV bulb clamp - check air distribution on coil - replace TXV • Recover refrigerant, evacuate & recharge
Gurgle or pulsing noise at expansion device or liquid line	<ul style="list-style-type: none"> • Air or non-condensibles in system 	<ul style="list-style-type: none"> • Recover refrigerant, evacuate & recharge

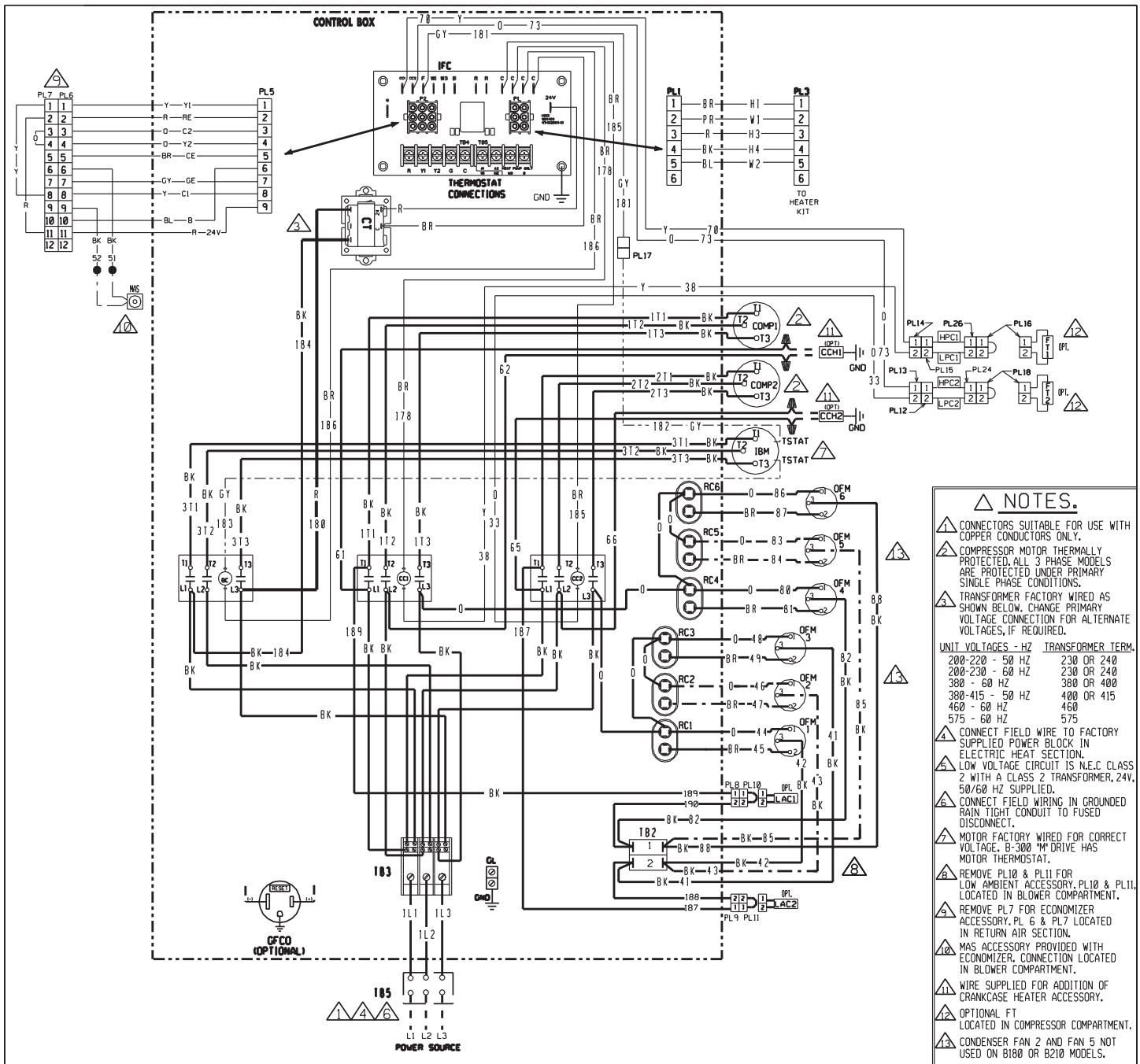

- NOTES.**
- ⚠ CONNECTORS SUITABLE FOR USE WITH COPPER CONDUCTORS ONLY.
 - ⚠ COMPRESSOR MOTOR THERMALLY PROTECTED, ALL 3 PHASE MODELS ARE PROTECTED UNDER PRIMARY SINGLE PHASE CONDITIONS.
 - ⚠ TRANSFORMER FACTORY WIRED AS SHOWN BELOW. CHANGE PRIMARY VOLTAGE CONNECTION FOR ALTERNATE VOLTAGES, IF REQUIRED.
- | UNIT VOLTAGES - HZ | TRANSFORMER TERM. |
|--------------------|-------------------|
| 200-220 - 50 HZ | 230 OR 240 |
| 200-230 - 60 HZ | 230 OR 240 |
| 300 - 60 HZ | 300 OR 400 |
| 300-415 - 50 HZ | 400 OR 415 |
| 460 - 60 HZ | 460 |
| 575 - 60 HZ | 575 |
- ⚠ CONNECT FIELD WIRE TO FACTORY SUPPLIED POWER BLOCK IN ELECTRIC HEAT SECTION.
 - ⚠ LOW VOLTAGE CIRCUIT IS N.E.C CLASS 2 WITH A CLASS 2 TRANSFORMER, 24V, 50/60 HZ SUPPLIED.
 - ⚠ CONNECT FIELD WIRING IN GROUNDED RAIN TIGHT CONDUIT TO FUSED DISCONNECT.
 - ⚠ MOTOR FACTORY WIRED FOR CORRECT VOLTAGE. B-300 "M" DRIVE HAS MOTOR THERMOSTAT.
 - ⚠ REMOVE PL10 & PL11 FOR LOW AMBIENT ACCESSORY. PL10 & PL11 LOCATED IN BLOWER COMPARTMENT.
 - ⚠ REMOVE PL7 FOR ECONOMIZER ACCESSORY. PL6 & PL7 LOCATED IN RETURN AIR SECTION.
 - ⚠ MAS ACCESSORY PROVIDED WITH ECONOMIZER. CONNECTION LOCATED IN BLOWER COMPARTMENT.
 - ⚠ WIRE SUPPLIED FOR ADDITION OF CRANKCASE HEATER ACCESSORY.
 - ⚠ OPTIONAL FT LOCATED IN COMPRESSOR COMPARTMENT.
 - ⚠ CONDENSER FAN 2 AND FAN 5 NOT USED ON B180 OR B210 MODELS.

COMPONENT CODE	
BC	BLOWER CONTACTOR
CC	COMPRESSOR CONTACTOR
CC	CRANKCASE HEATER
COMP	COMPRESSOR
CT	CONTROL TRANSFORMER
FT	FREEZE STAT
GFCO	GROUND FAULT CONVENIENCE OUTLET
GL	GROUND LUG
GND	GROUND
HPC	HIGH PRESSURE CONTROL
IBM	INDOOR BLOWER MOTOR BELT DRIVE
IFC	INTEGRATED FURNACE CONTROL
LAC	LOW AMBIENT COOLING CONTROL
LPC	LOW PRESSURE CONTROL
MAS	MIX AIR SENSOR
OFM	OUTDOOR FAN MOTOR
RC	RUN CAPACITOR
TDC	TIME DELAY CONTROL
TSTAT	MOTOR THERMOSTAT
PL	PLUG
PT	POWER TRANSFORMER
⚠	WIRE NUT

WIRING INFORMATION	
LINE VOLTAGE	
-FACTORY STANDARD	—————
-FACTORY OPTION	—————
-FIELD INSTALLED	-----
LOW VOLTAGE	
-FACTORY STANDARD	—————
-FACTORY OPTION	—————
-FIELD INSTALLED	-----
REPLACEMENT WIRE	
-MUST BE THE SAME SIZE AND TYPE OF INSULATION AS ORIGINAL (105° C MIN.)	
WARNING	
-CABINET MUST BE PERMANENTLY GROUNDED AND CONFORM TO I.E.C., N.E.C., C.E.C., AND LOCAL CODES AS APPLICABLE.	

WIRE COLOR CODE			
BK	BLACK	O	ORANGE
BR	BROWN	PR	PURPLE
BL	BLUE	R	RED
G	GREEN	W	WHITE
GY	GRAY	Y	YELLOW

WIRING DIAGRAM			
RLNL-B180/210/240/300			
208-230/460/575V 3 PH, 60 HZ.			
200-220/380-415 3PH, 50 HZ.			
PACKAGED A/C			
DR. BY	APP. BY	DATE	DWG. NO.
MGR		4-7-08	90-42517-30
			REV 05

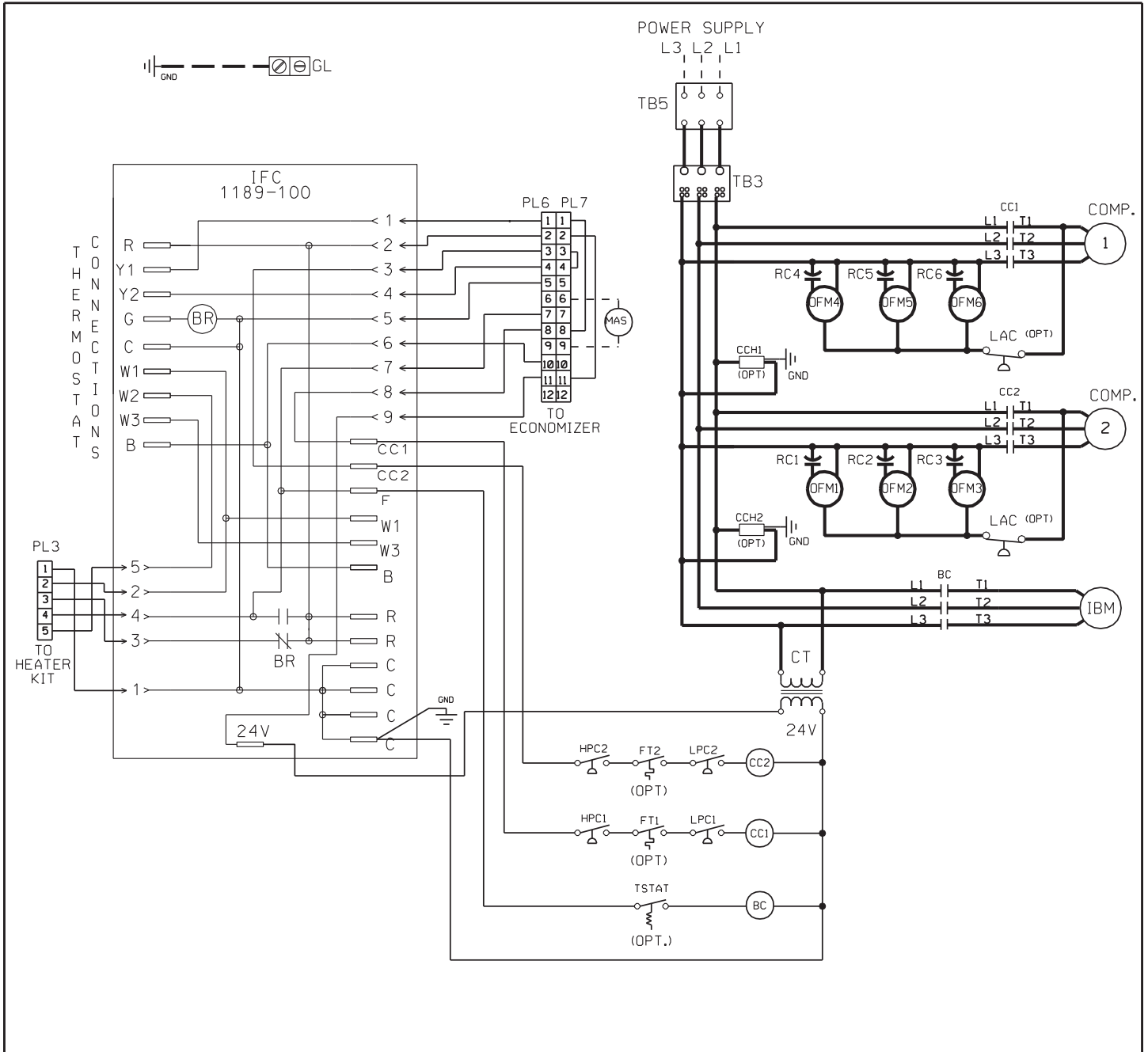

COMPONENT CODE	
BC	BLOWER MOTOR CONTACTOR
BR	BLOWER RELAY
CC	COMPRESSOR CONTACTOR
CCH	CRANKCASE HEATER
COMP	COMPRESSOR
CT	CONTROL TRANSFORMER
FT	FREEZE STAT
GL	GROUND LUG
GND	GROUND
HPC	HIGH PRESSURE CONTROL
IBM	INDOOR BLOWER MOTOR
IFC	INTEGRATED FURNACE CONTROL
LAC	LOW AMBIENT CONTROL
LPC	LOW PRESSURE CONTROL
MAS	MIXED AIR SENSOR
OFM	OUTDOOR FAN MOTOR
OPT	OPTIONAL
PL	PLUG
RC	RUN CAPACITOR
TB	TERMINAL BLOCK
TSTAT	MOTOR THERMOSTAT

WIRING INFORMATION	
LINE VOLTAGE	
-FACTORY STANDARD	—————
-FACTORY OPTION	-----
-FIELD INSTALLED	-----
LOW VOLTAGE	
-FACTORY STANDARD	—————
-FACTORY OPTION	-----
-FIELD INSTALLED	-----
REPLACEMENT WIRE	
-MUST BE THE SAME SIZE AND TYPE OF INSULATION AS ORIGINAL (105° C MIN.)	
WARNING	
-CABINET MUST BE PERMANENTLY GROUNDED AND CONFORM TO I.E.C., N.E.C., C.E.C., AND LOCAL CODES AS APPLICABLE.	

WIRE COLOR CODE			
BK	BLACK	O	ORANGE
BR	BROWN	PR	PURPLE
BL	BLUE	R	RED
G	GREEN	W	WHITE
GY	GRAY	Y	YELLOW

WIRING SCHEMATIC	
RLNL-B180/210/240/300	
208-230V, 3PH, 60HZ. / 460V, 3PH, 60HZ.	
575V, 3PH, 60 HZ.	
200-220/380-415V 3 PH, 50 HZ.	
PACKAGED A/C	

DR. BY	APP. BY	DATE	DWG. NO.	REV.
MGR		4-21-08	90-42517-33	03

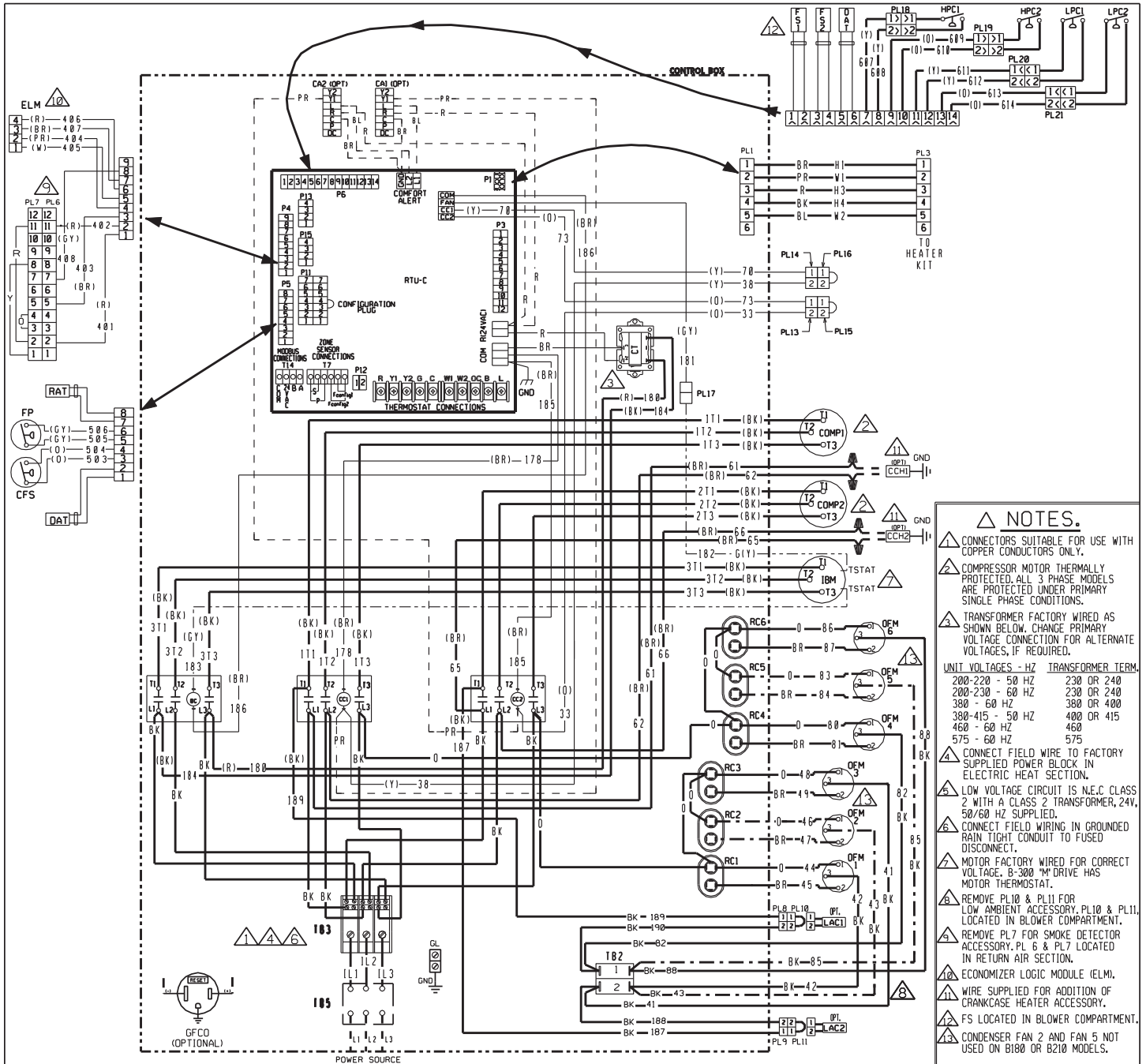

- ### NOTES.
- ⚠ CONNECTORS SUITABLE FOR USE WITH COPPER CONDUCTORS ONLY.
 - ⚠ COMPRESSOR MOTOR THERMALLY PROTECTED, ALL 3 PHASE MODELS ARE PROTECTED UNDER PRIMARY SINGLE PHASE CONDITIONS.
 - ⚠ TRANSFORMER FACTORY WIRE AS SHOWN BELOW. CHANGE PRIMARY VOLTAGE CONNECTION FOR ALTERNATE VOLTAGES, IF REQUIRED.
- | UNIT VOLTAGES - HZ | TRANSFORMER TERM. |
|--------------------|-------------------|
| 200-220 - 50 HZ | 230 OR 240 |
| 200-230 - 60 HZ | 230 OR 240 |
| 380 - 60 HZ | 380 OR 400 |
| 380-415 - 50 HZ | 400 OR 415 |
| 460 - 60 HZ | 460 |
| 575 - 60 HZ | 575 |
- ⚠ CONNECT FIELD WIRE TO FACTORY SUPPLIED POWER BLOCK IN ELECTRIC HEAT SECTION.
 - ⚠ LOW VOLTAGE CIRCUIT IS N.E.C. CLASS 2 WITH A CLASS 2 TRANSFORMER, 24V, 50/60 HZ SUPPLIED.
 - ⚠ CONNECT FIELD WIRING IN GROUNDED RAIN TIGHT CONDUIT TO FUSED DISCONNECT.
 - ⚠ MOTOR FACTORY WIRE FOR CORRECT VOLTAGE. B-300 "M" DRIVE HAS MOTOR THERMOSTAT.
 - ⚠ REMOVE PL10 & PL11 FOR LOW AMBIENT ACCESSORY. PL10 & PL11 LOCATED IN BLOWER COMPARTMENT.
 - ⚠ REMOVE PL7 FOR SMOKE DETECTOR ACCESSORY. PL 6 & PL7 LOCATED IN RETURN AIR SECTION.
 - ⚠ ECONOMIZER LOGIC MODULE (ELM).
 - ⚠ WIRE SUPPLIED FOR ADDITION OF CRANKCASE HEATER ACCESSORY.
 - ⚠ FS LOCATED IN BLOWER COMPARTMENT.
 - ⚠ CONDENSER FAN 2 AND FAN 5 NOT USED ON 8180 OR 8210 MODELS.

90-103079-03 REV. 01	COMPONENT CODE	WIRING INFORMATION	WIRE COLOR CODE			
	<table style="width: 100%; border: none;"> <tr> <td style="width: 50%; border: none;"> BC BLOWER CONTACTOR CA COMFORT ALERT MODULE CC COMPRESSOR CONTACTOR CCH CRANKCASE HEATER CFS CLOGGED FILTER SWITCH COMP COMPRESSOR CT CONTROL TRANSFORMER DAT DISCHARGE AIR SENSOR DISC DISCONNECT SWITCH FP FAN PROVING FS FREEZE SENSOR GFCO GROUND FAULT CONVENIENCE OUTLET GL GROUND LUG GND GROUND HPC HIGH PRESSURE CONTROL IBM INDOOR BLOWER MOTOR BELT DRIVE </td> <td style="width: 50%; border: none;"> LAC LOW AMBIENT COOLING CONTROL LC LIMIT CONTROL LPC LOW PRESSURE CONTROL DAT OUTSIDE AIR SENSOR OFM OUTDOOR FAN MOTOR PL PLUG RAT RETURN AIR SENSOR RC RUN CAPACITOR RTU-C ROOFTOP UNIT CONTROL TB TERMINAL BLOCK WIRE NUT </td> </tr> </table>	BC BLOWER CONTACTOR CA COMFORT ALERT MODULE CC COMPRESSOR CONTACTOR CCH CRANKCASE HEATER CFS CLOGGED FILTER SWITCH COMP COMPRESSOR CT CONTROL TRANSFORMER DAT DISCHARGE AIR SENSOR DISC DISCONNECT SWITCH FP FAN PROVING FS FREEZE SENSOR GFCO GROUND FAULT CONVENIENCE OUTLET GL GROUND LUG GND GROUND HPC HIGH PRESSURE CONTROL IBM INDOOR BLOWER MOTOR BELT DRIVE	LAC LOW AMBIENT COOLING CONTROL LC LIMIT CONTROL LPC LOW PRESSURE CONTROL DAT OUTSIDE AIR SENSOR OFM OUTDOOR FAN MOTOR PL PLUG RAT RETURN AIR SENSOR RC RUN CAPACITOR RTU-C ROOFTOP UNIT CONTROL TB TERMINAL BLOCK WIRE NUT	LINE VOLTAGE -FACTORY STANDARD ————— -FACTORY OPTION - - - - - -FIELD INSTALLED ———— LOW VOLTAGE -FACTORY STANDARD ————— -FACTORY OPTION - - - - - -FIELD INSTALLED ———— REPLACEMENT WIRE -MUST BE THE SAME SIZE AND TYPE OF INSULATION AS ORIGINAL (105° C MIN.) WARNING -CABINET MUST BE PERMANENTLY GROUNDED AND CONFORM TO I.E.C., N.E.C., C.E.C., AND LOCAL CODES AS APPLICABLE.	<table style="width: 100%; border: none;"> <tr> <td style="width: 50%; border: none;"> BK BLACK BR BROWN BL BLUE G GREEN GY GRAY </td> <td style="width: 50%; border: none;"> O ORANGE PR PURPLE R RED W WHITE Y YELLOW </td> </tr> </table>	BK BLACK BR BROWN BL BLUE G GREEN GY GRAY
BC BLOWER CONTACTOR CA COMFORT ALERT MODULE CC COMPRESSOR CONTACTOR CCH CRANKCASE HEATER CFS CLOGGED FILTER SWITCH COMP COMPRESSOR CT CONTROL TRANSFORMER DAT DISCHARGE AIR SENSOR DISC DISCONNECT SWITCH FP FAN PROVING FS FREEZE SENSOR GFCO GROUND FAULT CONVENIENCE OUTLET GL GROUND LUG GND GROUND HPC HIGH PRESSURE CONTROL IBM INDOOR BLOWER MOTOR BELT DRIVE	LAC LOW AMBIENT COOLING CONTROL LC LIMIT CONTROL LPC LOW PRESSURE CONTROL DAT OUTSIDE AIR SENSOR OFM OUTDOOR FAN MOTOR PL PLUG RAT RETURN AIR SENSOR RC RUN CAPACITOR RTU-C ROOFTOP UNIT CONTROL TB TERMINAL BLOCK WIRE NUT					
BK BLACK BR BROWN BL BLUE G GREEN GY GRAY	O ORANGE PR PURPLE R RED W WHITE Y YELLOW					
WIRING DIAGRAM						
RLNL-C180/210/240/300						
208-230/460/575V 3 PH, 60 HZ.						
PACKAGED A/C W/RTU-C						
DR. BY MGR	APP. BY DATE 4-13-09	DWG. NO. 90-103079-03	REV 01			

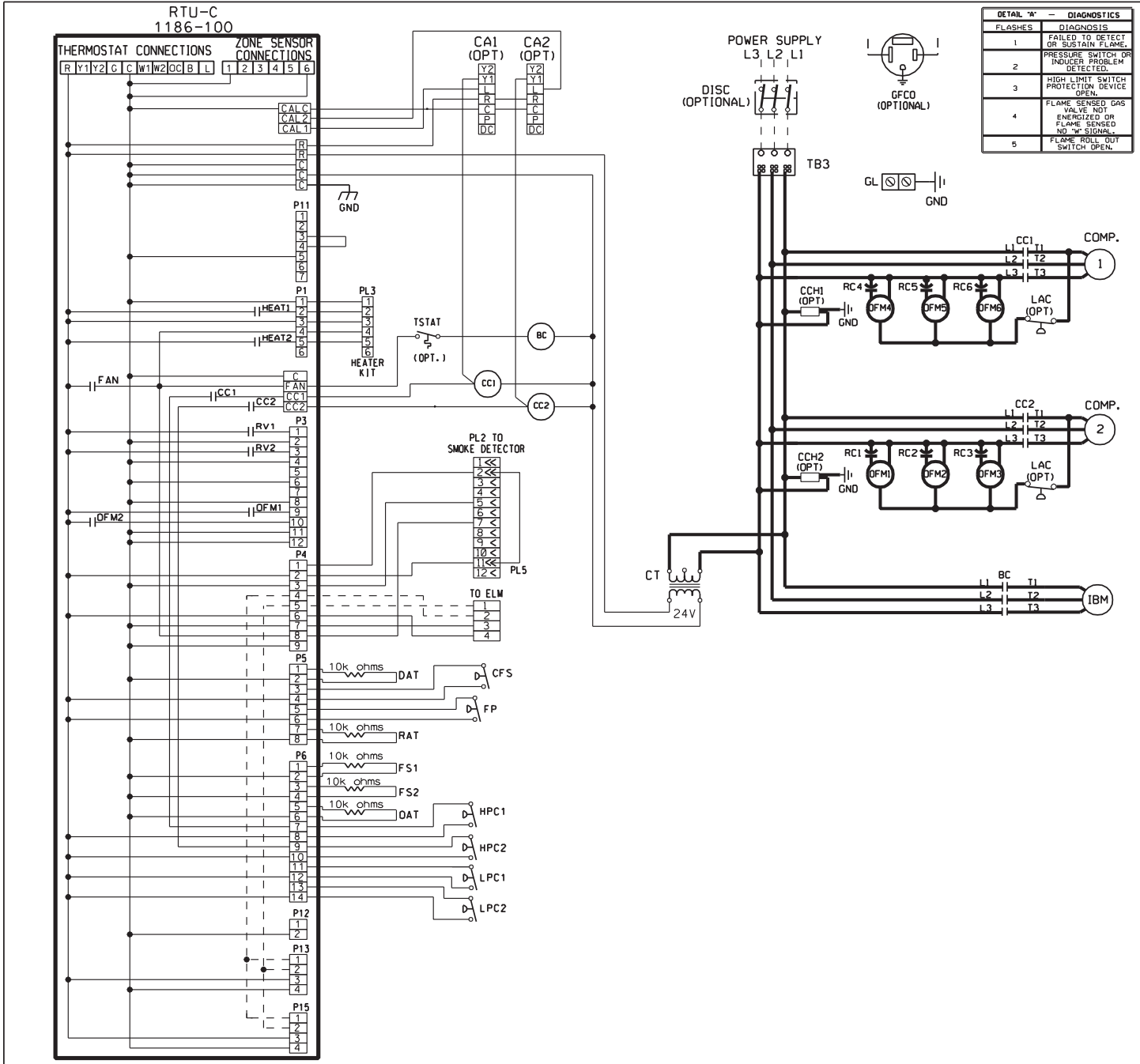

<p>90-103263-03</p> <p>REV 00</p>	COMPONENT CODE	WIRING INFORMATION	WIRE COLOR CODE
	WIRING SCHEMATIC	<p>RLNL-C180/210/240/300</p> <p>208-230/460/575V 3 PH, 60 HZ.</p> <p>PACKAGED A/C</p>	
	DR. BY	APP. BY	DATE
	MGR		7-16-09
	DWG. NO.	REV	
	90-103263-03	00	

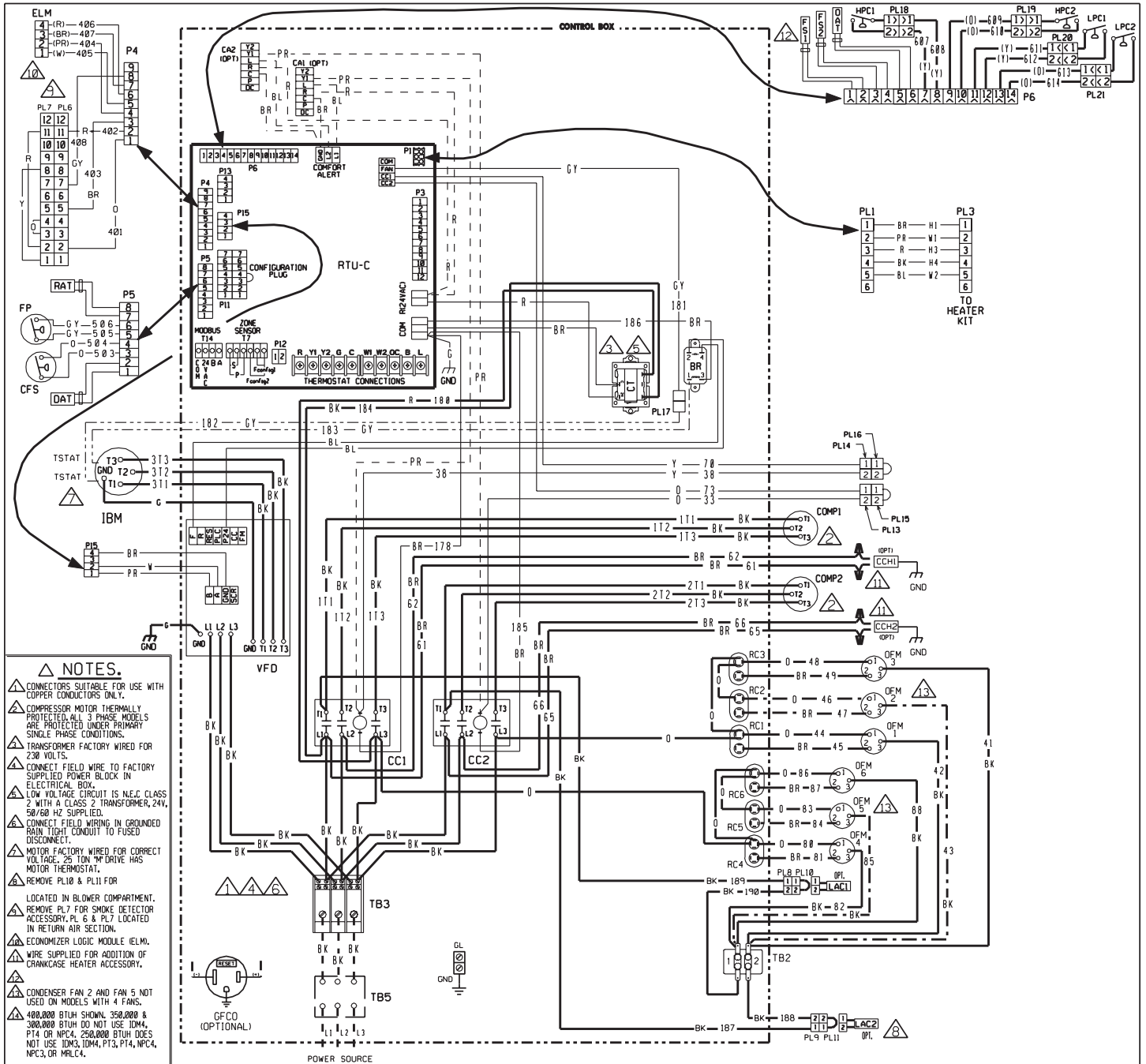

- NOTES.**
- ▲ CONNECTORS SUITABLE FOR USE WITH COPPER CONDUCTORS ONLY.
 - ▲ COMPRESSOR MOTOR THERMALLY PROTECTED. ALL 3 PHASE MODELS ARE PROTECTED UNDER PRIMARY SINGLE PHASE CONDITIONS.
 - ▲ TRANSFORMER FACTORY WIRE FOR 230 VOLTS.
 - ▲ CONNECT FIELD WIRE TO FACTORY SUPPLIED POWER BLOCK IN ELECTRICAL BOX.
 - ▲ LOW VOLTAGE CIRCUIT IS N.E.C. CLASS 2 WITH A CLASS 2 TRANSFORMER, 24V, 50/60 HZ SUPPLIED.
 - ▲ CONNECT FIELD WIRING IN GROUND RAIN TIGHT CONDUIT TO FUSED DISCONNECT.
 - ▲ MOTOR FACTORY WIRE FOR CORRECT VOLTAGE. 25 TON VFD DRIVE HAS MOTOR THERMOSTAT.
 - ▲ REMOVE PL10 & PL11 FOR LOCATED IN BLOWER COMPARTMENT.
 - ▲ REMOVE PL7 FOR SMOKE DETECTOR ACCESSORY. PL 6 & PL7 LOCATED IN RETURN AIR SECTION.
 - ▲ ECONOMIZER LOGIC MODULE (ELM). WIRE SUPPLIED FOR ADDITION OF CRANKCASE HEATER ACCESSORY.
 - ▲ CONDENSER FAN 2 AND FAN 5 NOT USED ON MODELS WITH 4 FANS.
 - ▲ 400,000 BTUH SHOWAL, 350,000 & 300,000 BTUH DO NOT USE 10M4, P14 OR NPC4. 250,000 BTUH DOES NOT USE 10M3, 10M4, P13, P14, NPC4, NPC3, OR HMLC4.

COMPONENT CODE	
BR	BLOWER RELAY
CA	COMFORT ALERT MODULE
CC	COMPRESSOR CONTACTOR
CCH	CRANKCASE HEATER
CFS	CLOGGED FILTER SWITCH
COMP	COMPRESSOR
CT	CONTROL TRANSFORMER
DAT	DISCHARGE AIR SENSOR
DISC	DISCONNECT SWITCH
FP	FAN PROVING
FS	FREEZE SENSOR
GFCD	GROUND FAULT CONVENIENCE OUTLET
GL	GROUND LUG
GND	GROUND
HPC	HIGH PRESSURE CONTROL
IBM	INDOOR BLOWER MOTOR BELT DRIVE
LAC	LOW AMBIENT COOLING CONTROL
LC	LIMIT CONTROL
LPC	LOW PRESSURE CONTROL
OAT	OUTSIDE AIR SENSOR
OFM	OUTDOOR FAN MOTOR
PL	PLUS
PL	RETURN AIR SENSOR
RAT	RUN CAPACITOR
RTU-C	ROOFTOP UNIT CONTROL
TB	TERMINAL BLOCK
VFD	VARIABLE FREQUENCY DRIVE
▲	WIRE NUT

WIRING INFORMATION	
LINE VOLTAGE	— (Solid line)
-FACTORY STANDARD	— (Dashed line)
-FACTORY OPTION	— (Dash-dot line)
-FIELD INSTALLED	— (Dotted line)
LOW VOLTAGE	— (Thin solid line)
-FACTORY STANDARD	— (Thin dashed line)
-FACTORY OPTION	— (Thin dash-dot line)
-FIELD INSTALLED	— (Thin dotted line)
REPLACEMENT WIRE	— (Double line)
-MUST BE THE SAME SIZE AND TYPE OF INSULATION AS ORIGINAL (105° C MIN.)	
WARNING	
-CABINET MUST BE PERMANENTLY GROUNDED AND CONFORM TO I.E.C., N.E.C., C.E.C., AND LOCAL CODES AS APPLICABLE.	

WIRE COLOR CODE	
BK	BLACK
BR	BROWN
BL	BLUE
G	GREEN
GY	GRAY
O	ORANGE
PR	PURPLE
R	RED
W	WHITE
Y	YELLOW

WIRING DIAGRAM
VFD MODELS
208-230/460V 3 PH, 60 HZ.
SELF-CONTAINED/PACKAGE A/C W/RTU-C

DR. BY	APP. BY	DATE	DWG. NO.	REV
MCB		01-04-12	90-103079-09	02

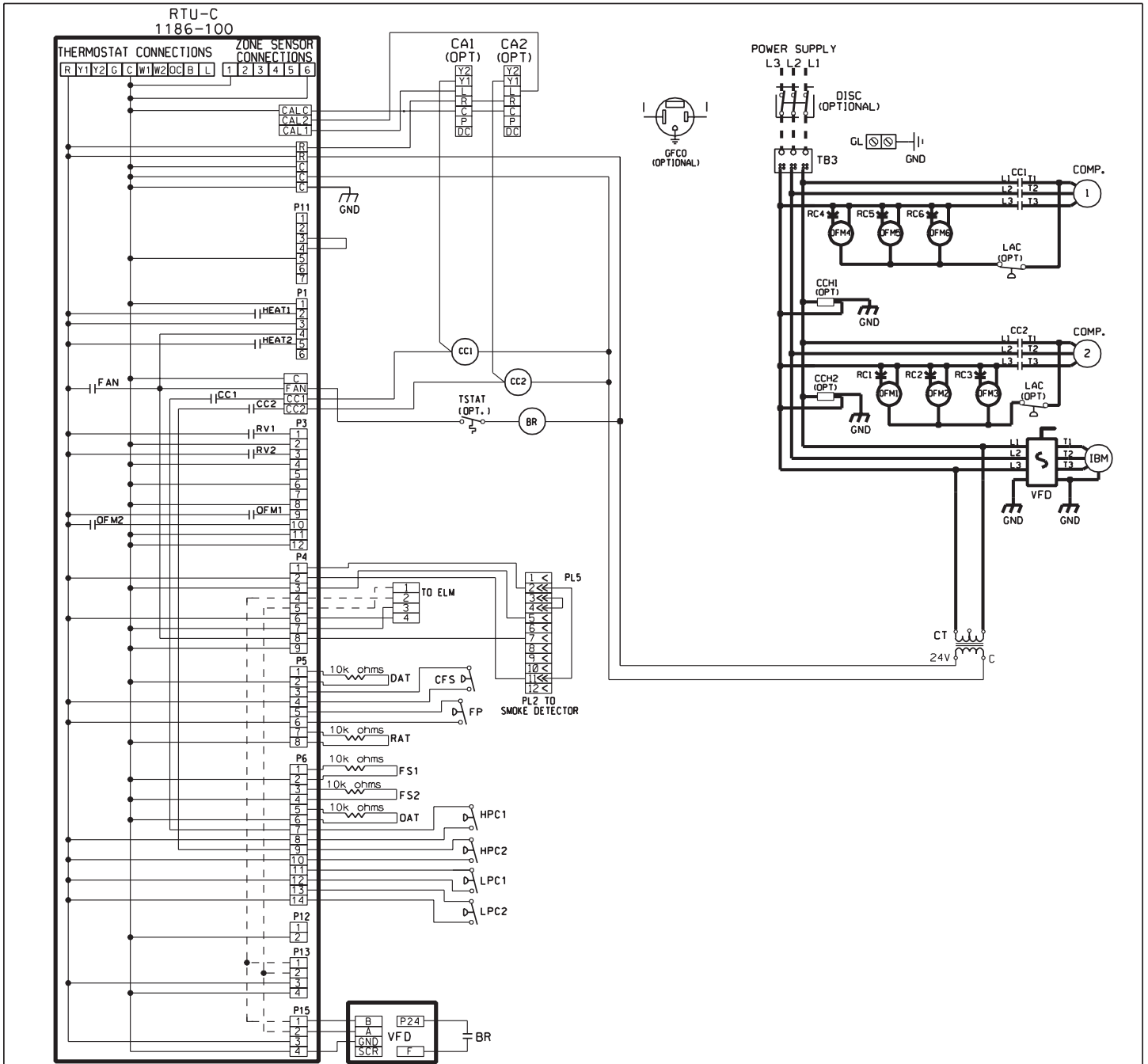

COMPONENT CODE	
BR	BLOWER RELAY
CA	COMFORT ALERT MODULE
CC	COMPRESSOR CONTACTOR
CCH	CRANKCASE HEATER
CFS	CLOGGED FILTER SWITCH
COMP	COMPRESSOR
CT	CONTROL TRANSFORMER
DAT	DISCHARGE AIR SENSOR
DISC	DISCONNECT SWITCH
FP	FAN PROVING
FS	FREEZE SENSOR
GFCO	GROUND FAULT CONVENIENCE OUTLET
GL	GROUND LUG
GND	GROUND
HPC	HIGH PRESSURE CONTROL
IBM	INDOOR BLOWER MOTOR BELT DRIVE
IFC	INTEGRATED FURNACE CONTROL
LAC	LOW AMBIENT COOLING CONTROL
LC	LIMIT CONTROL
LPC	LOW PRESSURE CONTROL
OAT	OUTSIDE AIR SENSOR
OFM	OUTDOOR FAN MOTOR
PL	PLUG
RAT	RETURN AIR SENSOR
RC	RUN CAPACITOR
RTU-C	ROOFTOP UNIT CONTROL
TB	TERMINAL BLOCK
VFD	VARIABLE FREQUENCY DRIVE
WIRE NUT	WIRE NUT

WIRING INFORMATION	
LINE VOLTAGE	—————
-FACTORY STANDARD	—————
-FACTORY OPTION	-----
-FIELD INSTALLED	-----
LOW VOLTAGE	—————
-FACTORY STANDARD	—————
-FACTORY OPTION	-----
-FIELD INSTALLED	-----
REPLACEMENT WIRE	—————
-MUST BE THE SAME SIZE AND TYPE OF INSULATION AS ORIGINAL (105° C MIN.)	
WARNING	
-CABINET MUST BE PERMANENTLY GROUNDED AND CONFORM TO I.E.C., N.E.C., C.E.C., AND LOCAL CODES AS APPLICABLE.	

WIRE COLOR CODE			
BK_	BLACK	O_	ORANGE
BR_	BROWN	PR_	PURPLE
BL_	BLUE	R_	RED
G_	GREEN	W_	WHITE
GY_	GRAY	Y_	YELLOW

WIRING SCHEMATIC	
VFD MODELS	
208-230/460V 3 PH, 60 HZ.	
SELF-CONTAINED/PACKAGE A/C W/RTU-C	
DR. BY	APP. BY
DATE	DWG. NO.
REV	

RLNL SERIES – 15 TON

SYSTEM CHARGE CHART - REFRIGERANT 410A 15 TON, CIRCUITS 1 & 2

- CAUTION: 1. BOTH COMPRESSORS MUST BE OPERATING BEFORE CHECKING REFRIGERANT CHARGE.
2. RETURN AIR TEMPERATURE MUST BE WITHIN COMFORT CONDITIONS BEFORE FINAL REFRIGERANT CHECK!

- INSTRUCTIONS: 1. MEASURE PRESSURE AT COMPRESSOR SUCTION AND DISCHARGE.
2. MEASURE OUTDOOR AMBIENT TO UNIT.
3. PLACE (X) ON CHART WHERE SUCTION AND DISCHARGE INTERSECT.
4. IF (X) IS BELOW OUTDOOR AMBIENT LINE, ADD CHARGE AND REPEAT STEPS 1-3.
5. IF (X) IS ABOVE OUTDOOR AMBIENT LINE, RECOVER EXCESS CHARGE AND REPEAT STEPS 1-3.

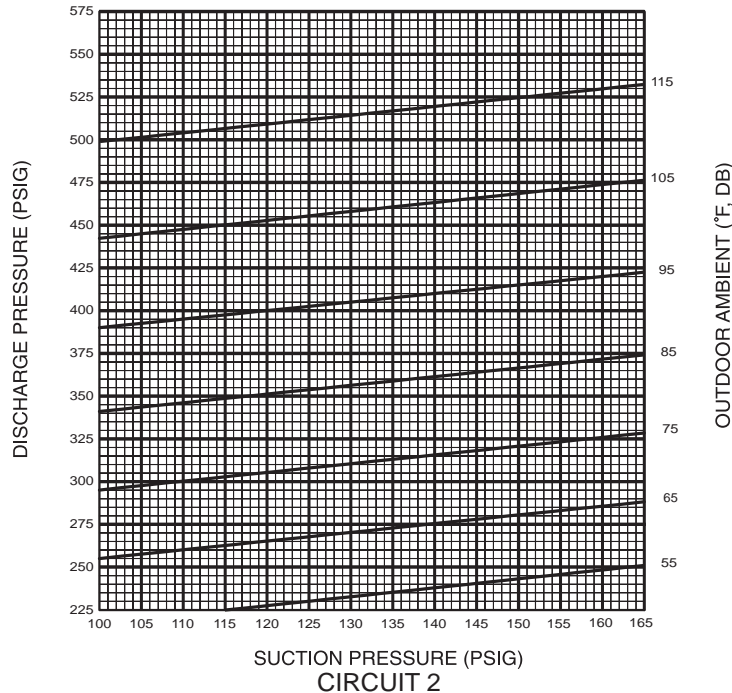
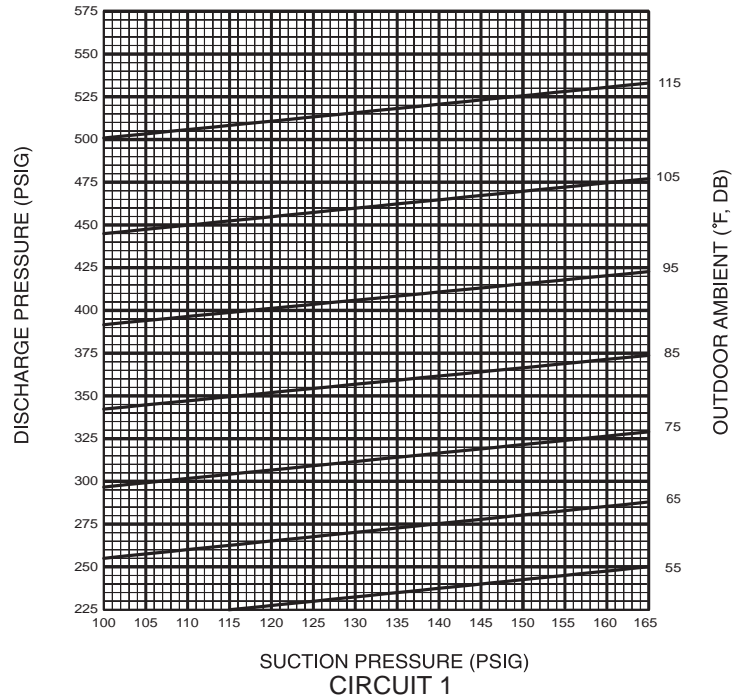

92-102778-01-01

RLNL SERIES – 17-1/2 TON

SYSTEM CHARGE CHART - REFRIGERANT 410A 17-1/2 ton, CIRCUITS 1 & 2

- CAUTION:**
- BOTH COMPRESSORS MUST BE OPERATING BEFORE CHECKING REFRIGERANT CHARGE.
 - RETURN AIR TEMPERATURE MUST BE WITHIN COMFORT CONDITIONS BEFORE FINAL REFRIGERANT CHECK!

- INSTRUCTIONS:**
- MEASURE PRESSURE AT COMPRESSOR SUCTION AND DISCHARGE.
 - MEASURE OUTDOOR AMBIENT TO UNIT.
 - PLACE (X) ON CHART WHERE SUCTION AND DISCHARGE INTERSECT.
 - IF (X) IS BELOW OUTDOOR AMBIENT LINE, ADD CHARGE AND REPEAT STEPS 1-3.
 - IF (X) IS ABOVE OUTDOOR AMBIENT LINE, RECOVER EXCESS CHARGE AND REPEAT STEPS 1-3.

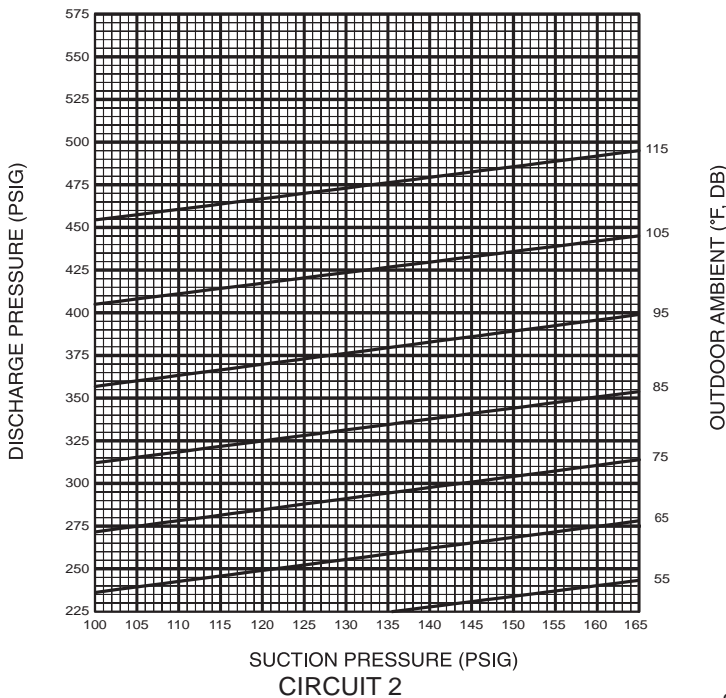
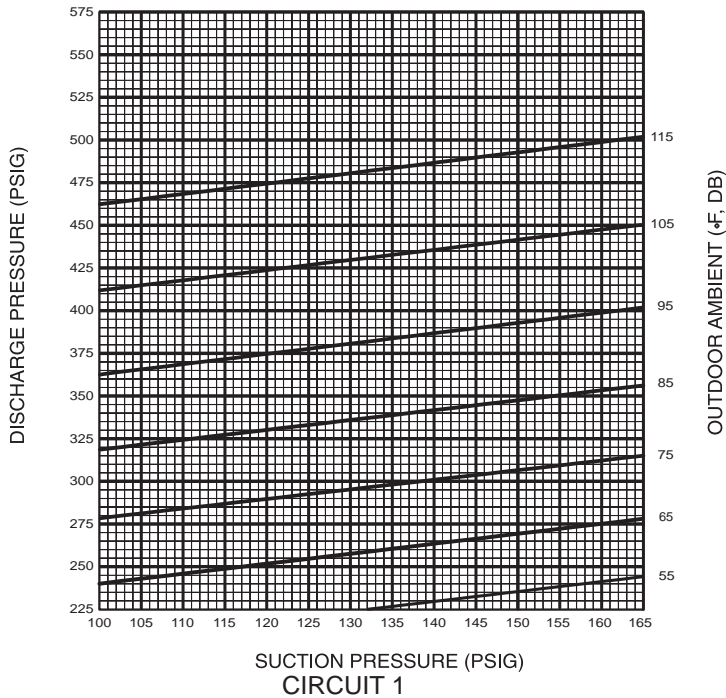

92-102778-02-01

RLNL SERIES – 20 TON

SYSTEM CHARGE CHART - REFRIGERANT 410A 20 TON, CIRCUITS 1 & 2

- CAUTION:**
- BOTH COMPRESSORS MUST BE OPERATING BEFORE CHECKING REFRIGERANT CHARGE.
 - RETURN AIR TEMPERATURE MUST BE WITHIN COMFORT CONDITIONS BEFORE FINAL REFRIGERANT CHECK!

- INSTRUCTIONS:**
- MEASURE PRESSURE AT COMPRESSOR SUCTION AND DISCHARGE.
 - MEASURE OUTDOOR AMBIENT TO UNIT.
 - PLACE (X) ON CHART WHERE SUCTION AND DISCHARGE INTERSECT.
 - IF (X) IS BELOW OUTDOOR AMBIENT LINE, ADD CHARGE AND REPEAT STEPS 1-3.
 - IF (X) IS ABOVE OUTDOOR AMBIENT LINE, RECOVER EXCESS CHARGE AND REPEAT STEPS 1-3.

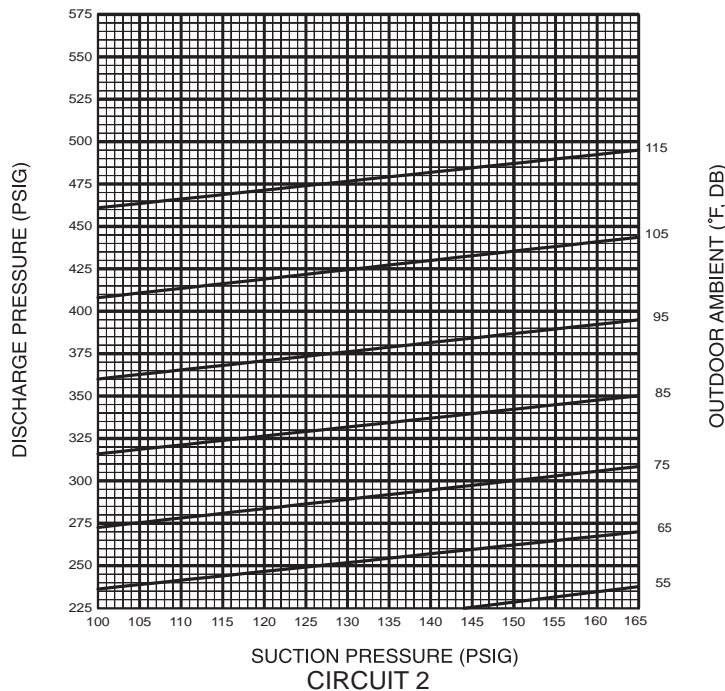
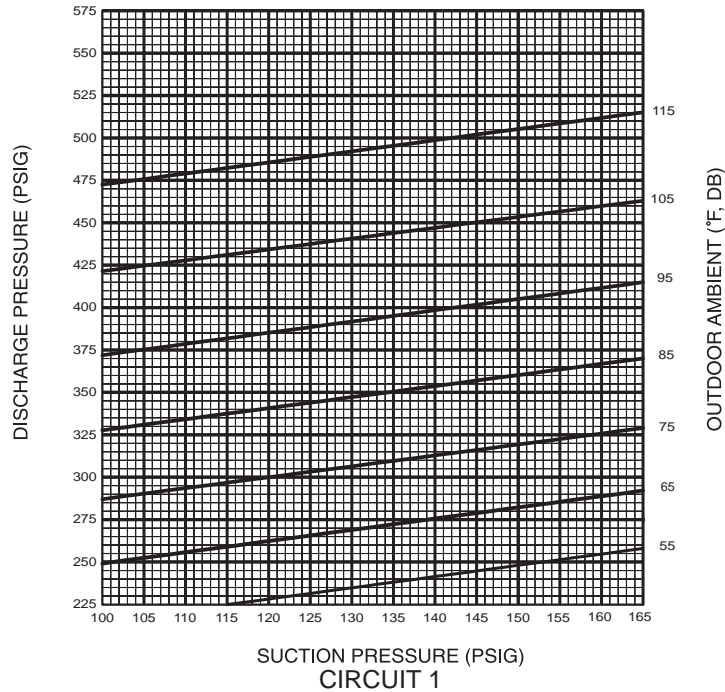

92-102778-03-01

RLNL SERIES – 25 TON

SYSTEM CHARGE CHART - REFRIGERANT 410A 25 TON, CIRCUITS 1 & 2

- CAUTION:**
- BOTH COMPRESSORS MUST BE OPERATING BEFORE CHECKING REFRIGERANT CHARGE.
 - RETURN AIR TEMPERATURE MUST BE WITHIN COMFORT CONDITIONS BEFORE FINAL REFRIGERANT CHECK!

- INSTRUCTIONS:**
- MEASURE PRESSURE AT COMPRESSOR SUCTION AND DISCHARGE.
 - MEASURE OUTDOOR AMBIENT TO UNIT.
 - PLACE (X) ON CHART WHERE SUCTION AND DISCHARGE INTERSECT.
 - IF (X) IS BELOW OUTDOOR AMBIENT LINE, ADD CHARGE AND REPEAT STEPS 1-3.
 - IF (X) IS ABOVE OUTDOOR AMBIENT LINE, RECOVER EXCESS CHARGE AND REPEAT STEPS 1-3.

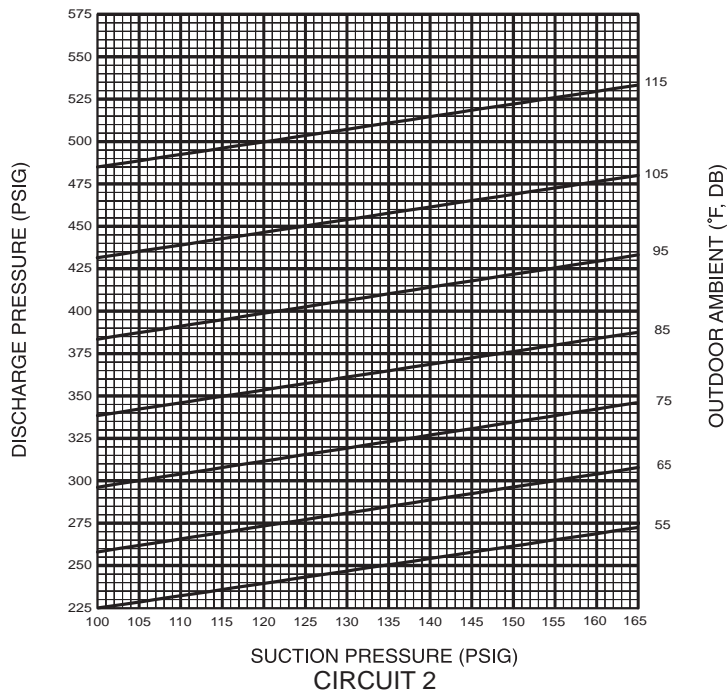
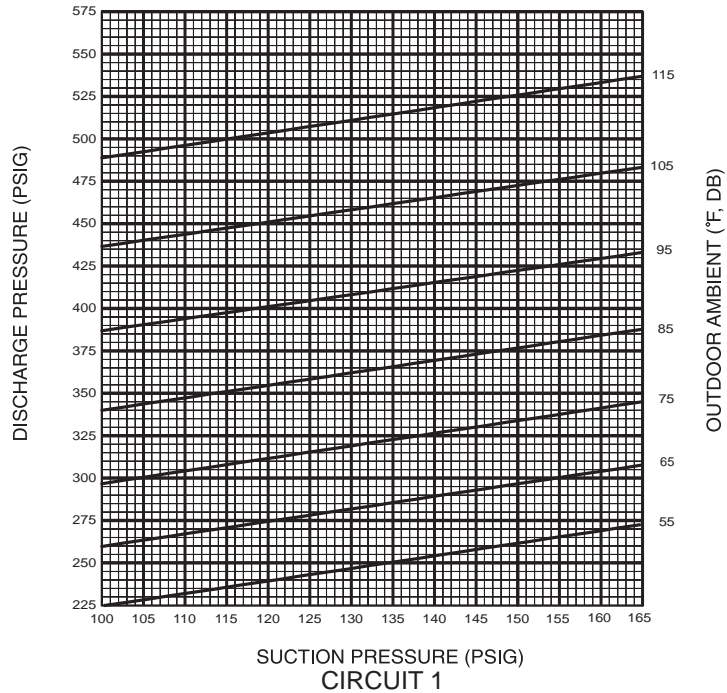

92-102778-04-01

