



Air

Package Air Conditioner
RLKN-B Series

The new degree of comfort.™

Rheem *Commercial Classic*® Series Package Air Conditioner



RLKN-B Standard Efficiency Series

Nominal Sizes 6 Tons [21.1 kW]
(3 Phase Models Only)



INTEGRATED AIR & WATER

FORM NO. S11-973

TABLE OF CONTENTS

Unit Features & Benefits	3-4
Selection Procedure	5
Model Number Identification	6
Options	7
General Data	
RLKN-B Series	8-9
Gross Systems Performance Data	
RLKN-B Series	10
Airflow Performance	
RLKN-B Series	11
Electrical Data	
RLKN-B Series	12
Electric Heater Kits	
RLKN-B Series	13-14
Dimensional Data	15-17
Accessories	18-25
Mechanical Specifications	26
Wiring Diagrams.....	27
Limited Warranty	28

Compressor Access



Evaporator Coil/Filter Access

- Return air filters, normally provided, are removed in this photo.

- Non-corrosive plastic condensate pan



Optional Electric Heater Kit



Blower Access

[] Designates Metric Conversions



STANDARD FEATURES INCLUDE:

- R-410A HFC refrigerant.
- Complete factory charged, wired and run tested.
- Scroll compressors with internal line break overload and high-pressure protection.
- Single stage compressor on all models.
- Convertible airflow.
- TXV refrigerant metering system.
- High Pressure and Low Pressure/Loss of charge protection standard on all models.
- Solid Core liquid line filter drier on each circuit.
- Single slab, single pass designed evaporator coil facilitates easy cleaning for maintained high efficiencies.
- Cooling operation up to 125 degree F ambient.
- Easily removable filter, blower, electric heat, and control access panels permits prompt service.
- Powder Paint Finish meets ASTM B117 steel coated on each side for maximum protection. G90 galvanized.
- One piece top cover and one piece base pan with drawn supply and return opening for superior water management.
- Externally mounted refrigerant gauge ports for easy service diagnostics.
- Factory or field-installed electric heat kits available up to 24 kW.
- Easy to install plug-in; slip in, 100% fully modulating economizer.
- Forkable base rails for easy handling and lifting.
- Single point electrical and gas connections.
- High performance belt drive motor with variable pitch pulleys and quick adjust belt system.
- Permanently lubricated evaporator, condenser and gas heat inducer motors.
- Condenser motors are internally protected, totally enclosed with shaft down design.
- 2 inch filter standard with slide out design.
- Colored and labeled wiring.
- Molded compressor plug.
- Micro Channel evaporators and condenser delivers superior performance with less refrigerant charge and less weight than conventional copper tube/aluminum fin coils. In addition the aluminum design has superior formicary corrosion protection and less potential for leaks due to elimination of tube rubbing potential. Its easier to clean and has a more robust surface.

RLKN-B SELECTION PROCEDURES

1. Determine cooling and heating requirements at design conditions.

Example:

Total cooling capacity	62,000 BTUH [18.17 kW]
Sensible cooling capacity	45,000 BTUH [13.18 kW]
Condenser entering air	95°F [35°C]
Evaporator entering air	63°F [17°C] wb/76°F [24°C] db
Indoor air flow	2050 CFM [967 L/s]
External static pressure	2.0 in wg

2. Select unit to meet cooling requirements.

Since total cooling is within the range of 6 ton [21.1 kW] unit enter cooling performance from the RLKN-B072 table, at 95°F [35°C] outdoor temperature, 63°F [17°C] wb entering indoor air, and 2050 CFM [967 L/s]:

Total capacity	66,100 BTUH [19.37 kW]
Power input	5.4 kW

And also, at 76°F [24°C] db indoor entering air, and using the formula at the bottom of the page:

Sensible capacity.....47,680 BTUH [13.97 kW]

3. Determine blower speed and power to meet the system requirements.

At the given external static pressure of 2.0 in wg, the belt model must be selected. Enter the belt drive blower performance table at 2050 CFM [967 L/s] and 2.0 in wg ESP:

RPM.....	793
Watts	690
Drive	L

4. Calculate indoor blower BTUH heat effect.

BTUH = Watts x 3.413 = 2355

5. Calculate net cooling capacities.

Net total cooling = 64,187 – 2355 = 61,832 BTUH [18.12 kW]

Net sensible cooling = 47,680 – 2355 = 45,325 BTUH [13.28 kW]

[] Designates Metric Conversions

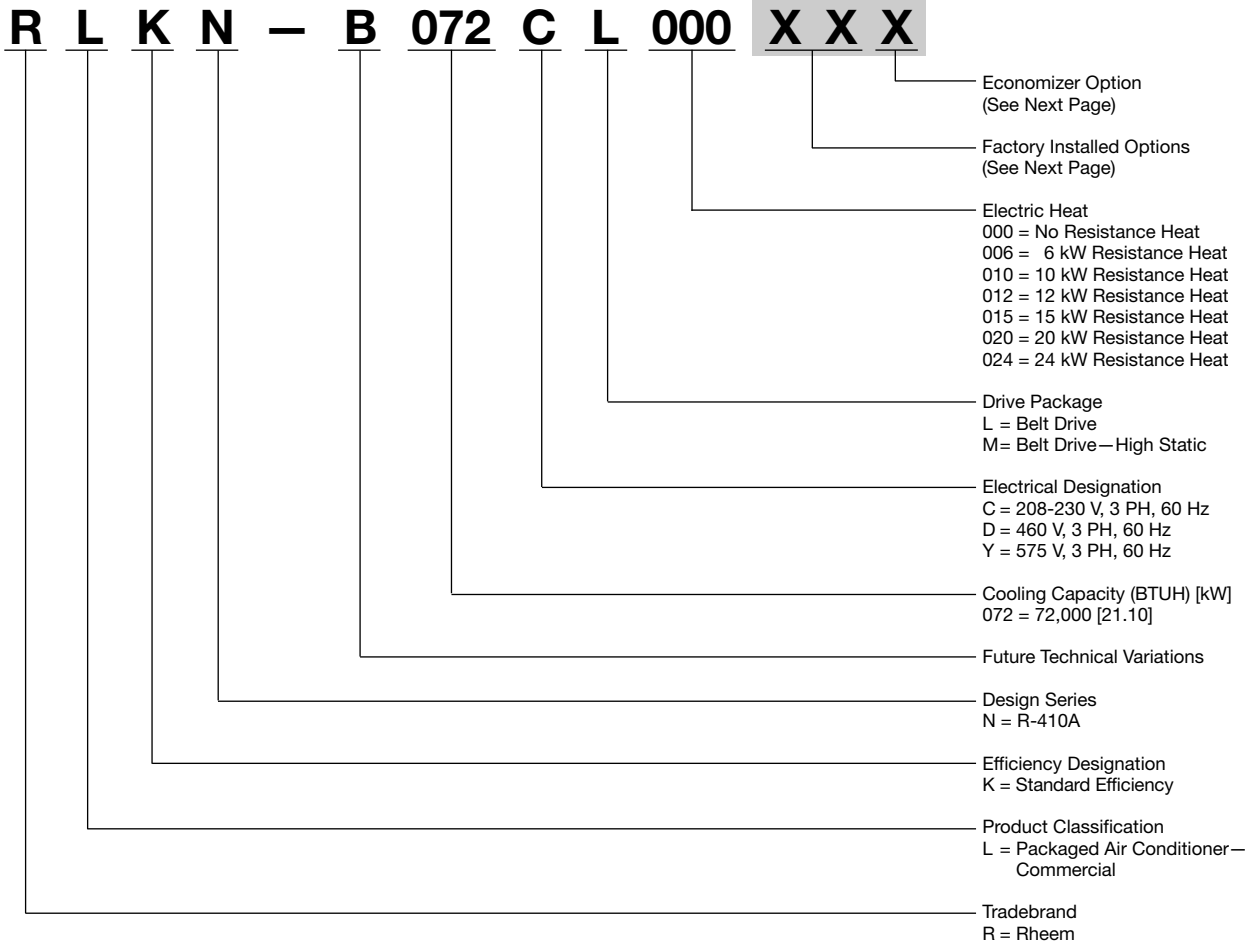

[] Designates Metric Conversions



FACTORY INSTALLED OPTION CODES FOR RLKN-B (6 Ton) [21.1 kW] (B072)

Option Code	Hail Guard	Non-Powered Convenience Outlet	Low Ambient/ Freeze Stat
AD	X		
AG		X	
AP			X
BY	X		X
BJ	X	X	
CX	X	X	X
JC		X	X

Example: RLKN-B072CL000XXX (where XX is factory installed option)

Example: No Options

RLKN-B072CL000

Example: No Options with Factory Installed Economizer

RLKN-B072CL000AAF

Example: Options with Hailguard with no Factory Installed Economizer

RLKN-B072CL000ADA

Example: Options same as above with Factory Installed Economizer

RLKN-B072CL000ADF

ECONOMIZER SELECTION FOR RLKN-B

	No Economizer	Single Enthalpy Economizer with Barometric Relief	Single Enthalpy Economizer with Smoke Detector
A	X		
F		X	
G			X

"x" indicates factory installed option.

[] Designates Metric Conversions

NOMINAL SIZES 6 TONS [21.1 kW] ASHRAE 90.1-1989 COMPLIANT MODELS

Model RLKN- Series	B072CL	B072CM	B072DL	B072DM
Cooling Performance¹				CONTINUED 
Gross Cooling Capacity Btu [kW]	71,000 [20.8]	71,000 [20.8]	71,000 [20.8]	71,000 [20.8]
EER/SEER ²	11.2/NA	11.2/NA	11.2/NA	11.2/NA
Nominal CFM/AHRI Rated CFM [L/s]	2400/2050 [1133/967]	2400/2050 [1133/967]	2400/2050 [1133/967]	2400/2050 [1133/967]
AHRI Net Cooling Capacity Btu [kW]	69,000 [20.22]	69,000 [20.22]	69,000 [20.22]	69,000 [20.22]
Net Sensible Capacity Btu [kW]	47,300 [13.86]	47,300 [13.86]	47,300 [13.86]	47,300 [13.86]
Net Latent Capacity Btu [kW]	21,700 [6.36]	21,700 [6.36]	21,700 [6.36]	21,700 [6.36]
IEER ³	12.5	12.5	12.5	12.5
Net System Power [kW]	6.19	6.19	6.19	6.19
Compressor				
No./Type	1/Scroll	1/Scroll	1/Scroll	1/Scroll
Outdoor Sound Rating (dB)⁴	83	83	83	83
Outdoor Coil—Fin Type	Louvered	Louvered	Louvered	Louvered
Tube Type	MicroChannel	MicroChannel	MicroChannel	MicroChannel
MicroChannel Depth [in] [mm]	0.7 [17.8]	0.7 [17.8]	0.7 [17.8]	0.7 [17.8]
Face Area sq. ft. [sq. m]	16.4 [1.52]	16.4 [1.52]	16.4 [1.52]	16.4 [1.52]
Rows / FPI [FPcm]	1 / 23 [9]	1 / 23 [9]	1 / 23 [9]	1 / 23 [9]
Indoor Coil—Fin Type	Louvered	Louvered	Louvered	Louvered
Tube Type	MicroChannel	MicroChannel	MicroChannel	MicroChannel
MicroChannel Depth [in] [mm]	1.3 [33]	1.3 [33]	1.3 [33]	1.3 [33]
Face Area sq. ft. [sq. m]	6 [0.56]	6 [0.56]	6 [0.56]	6 [0.56]
Rows / FPI [FPcm]	1 / 22 [9]	1 / 22 [9]	1 / 22 [9]	1 / 22 [9]
Refrigerant Control	TX Valves	TX Valves	TX Valves	TX Valves
Drain Connection No./Size in. [mm]	1/1 [25.4]	1/1 [25.4]	1/1 [25.4]	1/1 [25.4]
Outdoor Fan—Type	Propeller	Propeller	Propeller	Propeller
No. Used/Diameter in. [mm]	1/24 [609.6]	1/24 [609.6]	1/24 [609.6]	1/24 [609.6]
Drive Type/No. Speeds	Direct/1	Direct/1	Direct/1	Direct/1
CFM [L/s]	4000 [1888]	4000 [1888]	4000 [1888]	4000 [1888]
No. Motors/HP	1 at 1/3 HP	1 at 1/3 HP	1 at 1/3 HP	1 at 1/3 HP
Motor RPM	1075	1075	1075	1075
Indoor Fan—Type	FC Centrifugal	FC Centrifugal	FC Centrifugal	FC Centrifugal
No. Used/Diameter in. [mm]	1/11x10 [279x254]	1/11x10 [279x254]	1/11x10 [279x254]	1/11x10 [279x254]
Drive Type	Belt (Adjustable)	Belt (Adjustable)	Belt (Adjustable)	Belt (Adjustable)
No. Speeds	Single	Single	Single	Single
No. Motors	1	1	1	1
Motor HP	1 1/2	1 1/2	1 1/2	1 1/2
Motor RPM	1725	1725	1725	1725
Motor Frame Size	56	56	56	56
Filter—Type	Disposable	Disposable	Disposable	Disposable
Furnished	Yes	Yes	Yes	Yes
(NO.) Size Recommended in. [mm x mm x mm]	(4)2x16x16 [51x406x406]	(4)2x16x16 [51x406x406]	(4)2x16x16 [51x406x406]	(4)2x16x16 [51x406x406]
Refrigerant Charge Oz. [g]	70 [1984]	70 [1984]	70 [1984]	70 [1984]
Weights				
Net Weight lbs. [kg]	569 [258]	574 [260]	569 [258]	574 [260]
Ship Weight lbs. [kg]	576 [261]	579 [263]	576 [261]	579 [263]

[] Designates Metric Conversions

NOTES:

- Cooling Performance is rated at 95° F ambient, 80° F entering dry bulb, 67° F entering wet bulb. Gross capacity does not include the effect of fan motor heat. AHRI capacity is net and includes the effect of fan motor heat. Units are suitable for operation to ±20% of nominal cfm. Units are certified in accordance with the Unitary Air Conditioner Equipment certification program, which is based on AHRI Standard 210/240 or 360.
- EER and/or SEER are rated at AHRI conditions and in accordance with DOE test procedures.
- IEER is rated in accordance with AHRI Standard 210/240 or 360.
- Outdoor Sound Rating shown is tested in accordance with AHRI Standard 270.

NOMINAL SIZES 6 TONS [21.1 kW] ASHRAE 90.1-1999 COMPLIANT MODELS

Model RLKN- Series	B072YL	B072YM
Cooling Performance¹		
Gross Cooling Capacity Btu [kW]	71,000 [20.8]	71,000 [20.8]
EER/SEER ²	11.2/NA	11.2/NA
Nominal CFM/AHRI Rated CFM [L/s]	2400/2050 [1133/967]	2400/2050 [1133/967]
AHRI Net Cooling Capacity Btu [kW]	69,000 [20.22]	69,000 [20.22]
Net Sensible Capacity Btu [kW]	47,300 [13.86]	47,300 [13.86]
Net Latent Capacity Btu [kW]	21,700 [6.36]	21,700 [6.36]
IEER ³	12.5	12.5
Net System Power [kW]	6.19	6.19
Compressor		
No./Type	1/Scroll	1/Scroll
Outdoor Sound Rating (dB)⁴		
	83	83
Outdoor Coil—Fin Type		
Tube Type	Louvered	Louvered
MicroChannel Depth [in] [mm]	MicroChannel	MicroChannel
Face Area sq. ft. [sq. m]	0.7 [17.8]	0.7 [17.8]
Rows / FPI [FPcm]	16.4 [1.52]	16.4 [1.52]
	1 / 23 [9]	1 / 23 [9]
Indoor Coil—Fin Type		
Tube Type	Louvered	Louvered
MicroChannel Depth [in] [mm]	MicroChannel	MicroChannel
Face Area sq. ft. [sq. m]	1.3 [33]	1.3 [33]
Rows / FPI [FPcm]	6 [0.56]	6 [0.56]
Refrigerant Control	1 / 22 [9]	1 / 22 [9]
Drain Connection No./Size in. [mm]	TX Valves	TX Valves
	1/1 [25.4]	1/1 [25.4]
Outdoor Fan—Type		
No. Used/Diameter in. [mm]	Propeller	Propeller
Drive Type/No. Speeds	1/24 [609.6]	1/24 [609.6]
CFM [L/s]	Direct/1	Direct/1
No. Motors/HP	4000 [1888]	4000 [1888]
Motor RPM	1 at 1/3 HP	1 at 1/3 HP
	1075	1075
Indoor Fan—Type		
No. Used/Diameter in. [mm]	FC Centrifugal	FC Centrifugal
Drive Type	1/11x10 [279x254]	1/11x10 [279x254]
No. Speeds	Belt (Adjustable)	Belt (Adjustable)
No. Motors	Single	Single
Motor HP	1	1
Motor RPM	1 1/2	1 1/2
Motor Frame Size	1725	1725
	56	56
Filter—Type		
Furnished	Disposable	Disposable
(NO.) Size Recommended in. [mm x mm x mm]	Yes	Yes
	(4)2x16x16 [51x406x406]	(4)2x16x16 [51x406x406]
Refrigerant Charge Oz. [g]		
	70 [1984]	70 [1984]
Weights		
Net Weight lbs. [kg]	569 [258]	574 [260]
Ship Weight lbs. [kg]	576 [261]	579 [263]

[] Designates Metric Conversions

NOTES:

- Cooling Performance is rated at 95° F ambient, 80° F entering dry bulb, 67° F entering wet bulb. Gross capacity does not include the effect of fan motor heat. AHRI capacity is net and includes the effect of fan motor heat. Units are suitable for operation to $\pm 20\%$ of nominal cfm. Units are certified in accordance with the Unitary Air Conditioner Equipment certification program, which is based on AHRI Standard 210/240 or 360.
- EER and/or SEER are rated at AHRI conditions and in accordance with DOE test procedures.
- IEER is rated in accordance with AHRI Standard 210/240 or 360.
- Outdoor Sound Rating shown is tested in accordance with AHRI Standard 270.



GROSS SYSTEMS PERFORMANCE DATA—RLKN-B072

ENTERING INDOOR AIR @ 80°F [26.7°C] dbE ①											
wbE		71°F [21.7°C]			67°F [19.4°C]			63°F [17.2°C]			
CFM [L/s]		2255 [1064]	2050 [967]	1742 [822]	2255 [1064]	2050 [967]	1742 [822]	2255 [1064]	2050 [967]	1742 [822]	
DR ①		0.16	0.15	0.13	0.16	0.15	0.13	0.16	0.15	0.13	
OUTDOOR DRY BULB TEMPERATURE °F [°C]	75 [23.9]	Total BTUH [kW] Sens BTUH [kW] Power	85.0 [24.9] 46.2 [13.5] 4.5	83.5 [24.5] 44.1 [12.9] 4.5	81.2 [23.8] 41.0 [12.0] 4.4	80.1 [23.5] 54.7 [16.0] 4.4	78.7 [23.1] 52.3 [15.3] 4.4	76.5 [22.4] 48.6 [14.2] 4.3	74.8 [21.9] 62.2 [18.2] 4.4	73.5 [21.5] 59.4 [17.4] 4.3	71.4 [20.9] 55.2 [16.2] 4.3
	80 [26.7]	Total BTUH [kW] Sens BTUH [kW] Power	83.4 [24.4] 45.8 [13.4] 4.8	81.9 [24.0] 43.7 [12.8] 4.7	79.7 [23.3] 40.7 [11.9] 4.7	78.5 [23.0] 54.3 [15.9] 4.7	77.1 [22.6] 51.9 [15.2] 4.6	75.0 [22.0] 48.3 [14.1] 4.6	73.2 [21.5] 61.8 [18.1] 4.6	71.9 [21.1] 59.0 [17.3] 4.6	69.9 [20.5] 54.9 [16.1] 4.5
	85 [29.4]	Total BTUH [kW] Sens BTUH [kW] Power	81.6 [23.9] 45.2 [13.2] 5.0	80.2 [23.5] 43.2 [12.6] 5.0	78.0 [22.8] 40.1 [11.8] 4.9	76.8 [22.5] 53.7 [15.7] 5.0	75.4 [22.1] 51.3 [15.0] 4.9	73.3 [21.5] 47.7 [14.0] 4.8	71.4 [20.9] 61.2 [17.9] 4.9	70.1 [20.6] 58.5 [17.1] 4.8	68.2 [20.0] 54.4 [15.9] 4.8
	90 [32.2]	Total BTUH [kW] Sens BTUH [kW] Power	79.6 [23.3] 44.4 [13.0] 5.3	78.2 [22.9] 42.4 [12.4] 5.3	76.1 [22.3] 39.4 [11.6] 5.2	74.8 [21.9] 52.9 [15.5] 5.2	73.4 [21.5] 50.6 [14.8] 5.2	71.4 [20.9] 47.0 [13.8] 5.1	69.4 [20.3] 60.4 [17.7] 5.2	68.2 [20.0] 57.7 [16.9] 5.1	66.3 [19.4] 53.7 [15.7] 5.1
	95 [35]	Total BTUH [kW] Sens BTUH [kW] Power	77.4 [22.7] 43.4 [12.7] 5.7	76.1 [22.3] 41.4 [12.1] 5.6	74.0 [21.7] 38.5 [11.3] 5.5	72.6 [21.3] 51.9 [15.2] 5.6	71.3 [20.9] 49.6 [14.5] 5.5	69.3 [20.3] 46.1 [13.5] 5.4	67.3 [19.7] 59.4 [17.4] 5.5	66.1 [19.4] 56.7 [16.6] 5.4	64.2 [18.8] 52.8 [15.5] 5.4
	100 [37.8]	Total BTUH [kW] Sens BTUH [kW] Power	75.1 [22.0] 42.1 [12.3] 6.0	73.7 [21.6] 40.3 [11.8] 5.9	71.7 [21.0] 37.4 [11.0] 5.9	70.2 [20.6] 50.7 [14.9] 5.9	68.9 [20.2] 48.4 [14.2] 5.9	67.1 [19.7] 45.0 [13.2] 5.8	64.9 [19.0] 58.2 [17.0] 5.8	63.7 [18.7] 55.6 [16.3] 5.8	62.0 [18.2] 51.7 [15.1] 5.7
	105 [40.6]	Total BTUH [kW] Sens BTUH [kW] Power	72.5 [21.2] 40.7 [11.9] 6.4	71.2 [20.9] 38.9 [11.4] 6.3	69.2 [20.3] 36.2 [10.6] 6.2	67.6 [19.8] 49.3 [14.4] 6.3	66.4 [19.5] 47.1 [13.8] 6.2	64.6 [18.9] 43.8 [12.8] 6.1	62.3 [18.3] 56.7 [16.6] 6.2	61.2 [17.9] 54.2 [15.9] 6.1	59.5 [17.4] 50.4 [14.8] 6.1
	110 [43.3]	Total BTUH [kW] Sens BTUH [kW] Power	69.7 [20.4] 39.1 [11.5] 6.8	68.4 [20.1] 37.3 [10.9] 6.7	66.6 [19.5] 34.7 [10.2] 6.6	64.8 [19.0] 47.6 [14.0] 6.7	63.7 [18.7] 45.5 [13.3] 6.6	61.9 [18.1] 42.3 [12.4] 6.5	59.5 [17.4] 55.1 [16.1] 6.6	58.4 [17.1] 52.6 [15.4] 6.5	56.8 [16.7] 49.0 [14.3] 6.4
	115 [46.1]	Total BTUH [kW] Sens BTUH [kW] Power	66.7 [19.5] 37.2 [10.9] 7.2	65.5 [19.2] 35.6 [10.4] 7.1	63.7 [18.7] 33.1 [9.7] 7.0	61.8 [18.1] 45.8 [13.4] 7.1	60.7 [17.8] 43.7 [12.8] 7.0	59.1 [17.3] 40.7 [11.9] 6.9	56.5 [16.6] 53.3 [15.6] 7.0	55.5 [16.3] 50.9 [14.9] 6.9	54.0 [15.8] 47.3 [13.9] 6.9
	120 [48.9]	Total BTUH [kW] Sens BTUH [kW] Power	63.5 [18.6] 35.2 [10.3] 7.6	62.4 [18.3] 33.6 [9.9] 7.6	60.7 [17.8] 31.3 [9.2] 7.5	58.7 [17.2] 43.7 [12.8] 7.5	57.6 [16.9] 41.8 [12.2] 7.5	56.0 [16.4] 38.9 [11.4] 7.4	53.3 [15.6] 51.2 [15.0] 7.5	52.4 [15.3] 48.9 [14.3] 7.4	50.9 [14.9] 45.5 [13.3] 7.3
125 [51.7]	Total BTUH [kW] Sens BTUH [kW] Power	60.1 [17.6] 32.9 [9.7] 8.1	59.1 [17.3] 31.5 [9.2] 8.0	57.4 [16.8] 29.3 [8.6] 7.9	55.3 [16.2] 41.5 [12.2] 8.0	54.3 [15.9] 39.6 [11.6] 7.9	52.8 [15.5] 36.9 [10.8] 7.8	49.9 [14.6] 49.0 [14.3] 7.9	49.0 [14.4] 46.8 [13.7] 7.9	47.7 [14.0] 43.5 [12.7] 7.7	

DR —Depression ratio
dbE —Entering air dry bulb
wbE —Entering air wet bulb

Total —Total capacity x 1000 BTUH
Sens —Sensible capacity x 1000 BTUH
Power —KW input

NOTES: ① When the entering air dry bulb is other than 80°F [27°C], adjust the sensible capacity from the table by adding $[1.10 \times \text{CFM} \times (1 - \text{DR}) \times (\text{dbE} - 80)]$.

[] Designates Metric Conversions



BELT-DRIVE AIRFLOW PERFORMANCE – 6 TON [21.10 kW] MODEL

Air Flow CFM [L/s]		Capacity 6 Ton [21.10 kW] Voltage 208/230-460 & 575–3 Phase										External Static Pressure—Inches of Water [kPa]																			
		0.1 [.02]		0.2 [.05]		0.3 [.07]		0.4 [.10]		0.5 [.12]		0.6 [.15]		0.7 [.17]		0.8 [.20]		0.9 [.22]		1.0 [.25]		1.1 [.27]		1.2 [.30]		1.3 [.32]		1.4 [.35]		1.5 [.37]	
		RPM	W	RPM	W	RPM	W	RPM	W	RPM	W	RPM	W	RPM	W	RPM	W	RPM	W	RPM	W	RPM	W	RPM	W	RPM	W	RPM	W	RPM	W
1800 [850]	—	—	—	—	—	—	—	785	560	850	605	895	650	930	670	975	720	1010	760	1050	800	1090	850	1120	880	1150	940	1180	980	1210	1015
1900 [897]	—	—	—	—	785	580	830	615	875	660	915	700	955	740	990	770	1020	815	1070	855	1105	925	1135	960	1165	1015	1195	1075	1220	1115	
2000 [944]	—	—	775	600	815	625	860	675	895	720	930	750	975	800	1015	840	1050	900	1085	940	1120	1000	1145	1035	1175	1090	1205	1150	1230	1205	
2100 [991]	—	—	810	650	840	680	880	740	920	780	955	820	995	880	1030	920	1065	960	1100	1025	1130	1060	1160	1130	1190	1180	1220	1250	1240	1295	
2200 [1038]	780	660	825	700	865	750	910	810	945	850	980	880	1015	930	1050	1000	1080	1045	1120	1100	1145	1160	1180	1220	1205	1260	1230	1330	1255	1380	
2300 [1085]	815	720	855	760	890	830	930	870	960	910	1000	960	1035	1005	1065	1060	1100	1130	1135	1180	1160	1250	1200	1325	1220	1370	1240	1425	—	—	
2400 [1133]	845	780	880	835	920	900	950	945	990	990	1025	1050	1055	1110	1085	1155	1120	1215	1150	1335	1185	1355	1220	1430	1235	1470	1255	1525	—	—	
2500 [1180]	870	855	910	915	945	975	980	1020	1020	1085	1045	1140	1080	1200	1110	1260	1135	1300	1175	1390	1205	1450	1230	1530	1250	1580	1295	1630	—	—	
2600 [1227]	900	945	940	1005	975	1060	1005	1105	1040	1175	1065	1225	1100	1295	1135	1350	1165	1425	1200	1505	1225	1580	1240	1635	1270	1665	—	—	—	—	
2700 [1274]	930	1075	970	1100	1000	1145	1030	1200	1060	1260	1090	1335	1125	1395	1155	1470	1185	1540	1220	1615	1235	1675	1255	1730	—	—	—	—	—	—	
2800 [1321]	960	1150	1000	1195	1025	1240	1055	1305	1085	1350	1115	1440	1145	1510	1180	1560	1210	1620	1235	1740	1250	1775	1295	—	—	—	—	—	—	—	
2900 [1369]	1000	1245	1025	1290	1055	1350	1080	1400	1120	1480	1145	1550	1180	1640	1210	1720	1225	1700	1250	1850	1290	1895	—	—	—	—	—	—	—	—	
3000 [1416]	1025	1325	1050	1395	1080	1455	1115	1540	1145	1620	1175	1655	1210	1755	1225	1840	1245	1910	1295	1970	—	—	—	—	—	—	—	—	—	—	

NOTE: L-Drive left of bold line, M-Drive right of bold line.

Drive Package	L						M							
	Motor H.P. [w]	1-1/2 [1118.5]						1-1/2 [1118.5]						
Blower Sheave	6.4 Pitch Diameter						6.4 Pitch Diameter							
Motor Sheave	Adjustable 2.8-3.8 Pitch Diameter						Adjustable 3.4-4.4 Pitch Diameter							
Turns Open	0	1	2	3	4	5	6	0	1	2	3	4	5	6
RPM	1100	1050	1000	945	895	845	780	1295	1230	1195	1145	1100	1050	1000

Factory sheave settings are shown in bold print.

COMPONENT AIR RESISTANCE

Component	Standard Indoor Airflow—CFM [L/s]				Resistance—Inches Water [kPa]			
	2200 [944]	2400 [1133]	2600 [1227]	2800 [1321]	3200 [1510]	3400 [1605]		
Wet Coil	.079	.090	.102	.118	.128	.135		
Downflow	.061	.079	.089	.100	.108	.112		
R.S.I. Economizer	.09	.10	.11	.12	.13	.15		
R.A. Damper								

NOTES:

- Performance shown with dry coil & standard 2" [50.8 mm] filters.
- Standard CFM @ .075 lbs./cu. ft.
- Motor efficiency = 80%
- BHP = $\frac{\text{Watts} \times \text{Motor Eff.}}{746}$
- Add component resistance to duct static to determine E.S.P. as shown on charts.

[] Designates Metric Conversions



ELECTRICAL DATA – RLKN SERIES

		B072CL	B072CM	B072DL	B072DM	B072YL	B072YM
Unit Information	Unit Operating Voltage Range	187-253	187-253	414-506	414-506	518-632	518-632
	Volts	208/230	208/230	460	460	575	575
	Phase	3	3	3	3	3	3
	Hz	60	60	60	60	60	60
	Minimum Circuit Ampacity	33	33	15	15	12	12
	Minimum Overcurrent Protection Device Size	40	40	20	20	15	15
	Maximum Overcurrent Protection Device Size	50	50	20	20	15	15
Compressor Motor	No.	1	1	1	1	1	1
	Volts	208/230	208/230	460	460	575	575
	Phase	3	3	3	3	3	3
	RPM	3450	3450	3450	3450	3450	3450
	HP, Compressor 1	5	5	5	5	5	5
	Amps (RLA), Comp. 1	19.6	19.6	8.2	8.2	6.6	6.6
	Amps (LRA), Comp. 1	136	136	66.1	66.1	55.3	55.3
Condenser Motor	No.	1	1	1	1	1	1
	Volts	208/230	208/230	460	460	575	575
	Phase	1	1	1	1	1	1
	HP	1/3	1/3	1/3	1/3	1/3	1/3
	Amps (FLA, each)	2.2	2.2	1.5	1.5	1	1
	Amps (LRA, each)	4.7	4.7	2.4	2.4	1.5	1.5
Evaporator Fan	No.	1	1	1	1	1	1
	Volts	208/230	208/230	460	460	575	575
	Phase	3	3	3	3	3	3
	HP	1 1/2	1 1/2	1 1/2	1 1/2	1 1/2	1 1/2
	Amps (FLA, each)	5.8	5.8	2.8	2.8	2.1	2.1
	Amps (LRA, each)	34	34	17	17	13.1	13.1

208/240 VOLT, THREE PHASE, 60 HZ. AUXILIARY ELECTRIC HEATER KITS CHARACTERISTICS AND APPLICATION													
Single Power Supply for Both Unit and Heater Kit				Heater Kit				Air Conditioner				Separate Power Supply for Both Unit and Heater Kit	
Model No. RLKN-	RXJJ-Heater Kit Nominal kW	No. of Sequence Steps	Rated Heater kW @ 208/240V	Heater kBTU/Hr @ 208/240V	Heater Amp @ 208/240V	Unit Min. Ckt. Ampacity @ 240V	Over Current Protective Device Size		Min. Ckt. Ampacity 208/240V	Max. Fuse Size 208/240V	Min. Circuit Ampacity 208/240V	Over Current Protective Device Size	
							Min./Max. 208	Min./Max. 240				Min./Max. 208	Min./Max. 240V
B072CL	No Heat	—	—	—	—	33/33	40/50	40/50	—	—	33/33	40/50	40/50
	A06C	1	4.2/5.6	14.33/19.1	11.7/13.5	33/33	40/50	40/50	15/17	15/20	33/33	40/50	40/50
	A10C	1	7.2/9.6	24.56/32.75	20/23.1	33/37	40/50	40/50	25/29	25/30	33/33	40/50	40/50
	A15C	1	10.8/14.4	36.84/49.13	30.1/34.7	45/51	45/50	60/60	38/44	40/45	33/33	40/50	40/50
	A20C	1	14.4/19.2	49.13/65.5	40/46.3	58/66	60/60	70/70	50/58	50/60	33/33	40/50	40/50
B072CM	A24C	1	18/24	61.41/81.88	50/57.7	70/80	70/70	80/80	63/73	70/80	33/33	40/50	40/50
	No Heat	—	—	—	—	33/33	40/50	40/50	—	—	33/33	40/50	40/50
	A06C	1	4.2/5.6	14.33/19.1	11.7/13.5	33/33	40/50	40/50	15/17	15/20	33/33	40/50	40/50
	A10C	1	7.2/9.6	24.56/32.75	20/23.1	33/37	40/50	40/50	25/29	25/30	33/33	40/50	40/50
	A15C	1	10.8/14.4	36.84/49.13	30.1/34.7	45/51	45/50	60/60	38/44	40/45	33/33	40/50	40/50
B072DL	A20C	1	14.4/19.2	49.13/65.5	40/46.3	58/66	60/60	70/70	50/58	50/60	33/33	40/50	40/50
	A24C	1	18/24	61.41/81.88	50/57.7	70/80	70/70	80/80	63/73	70/80	33/33	40/50	40/50

480 VOLT, THREE PHASE, 60 HZ. AUXILIARY ELECTRIC HEATER KITS CHARACTERISTICS AND APPLICATION													
Single Power Supply for Both Unit and Heater Kit				Heater Kit				Air Conditioner				Separate Power Supply for Both Unit and Heater Kit	
Model No. RLKN-	RXJJ-Heater Kit Nominal kW	No. of Sequence Steps	Rated Heater kW @ 480V	Heater kBTU/Hr @ 480V	Heater Amp @ 480V	Unit Min. Ckt. Ampacity @ 480V	Over Current Protective Device Size		Min. Ckt. Ampacity 480V	Max. Fuse Size 480V	Min. Circuit Ampacity 480V	Over Current Protective Device Size	
							Min./Max. 480V	Min./Max. 480V				Min./Max. 480V	Min./Max. 480V
B072DL	No Heat	—	—	—	—	15	20/20	20/20	—	—	15	20/20	20/20
	A06D	1	5.6	19.1	6.7	15	20/20	20/20	9	15	15/0	20/20	0/0
	A10D	1	9.6	32.75	11.6	19	20/20	20/20	15	15	15/0	20/20	0/0
	A15D	1	14.4	49.13	17.4	26	30/30	30/30	22	25	15/0	20/20	0/0
	A20D	1	19.2	65.5	23.3	33	35/35	35/35	30	30	15/0	20/20	0/0
B072DM	A24D	1	24	81.88	28.9	40	40/40	40/40	37	40	15/0	20/20	0/0
	No Heat	—	—	—	—	15	20/20	20/20	—	—	15	20/20	—
	A06D	1	5.6	19.1	6.7	15	20/20	20/20	9	15	15/0	20/20	0/0
	A10D	1	9.6	32.75	11.6	19	20/20	20/20	15	15	15/0	20/20	0/0
	A15D	1	14.4	49.13	17.4	26	30/30	30/30	22	25	15/0	20/20	0/0
B072DM	A20D	1	19.2	65.5	23.3	33	35/35	35/35	30	30	15/0	20/20	0/0
	A24D	1	24	81.88	28.9	40	40/40	40/40	37	40	15/0	20/20	0/0

* = For Canadian use only. Uses "pr" fuses for inductive circuit.
 + = Field installed only.

600 VOLT, THREE PHASE, 60 HZ, AUXILIARY ELECTRIC HEATER KITS CHARACTERISTICS AND APPLICATION														
Separate Power Supply for Both Unit and Heater Kit														
Model No. RLKN-	Single Power Supply for Both Unit and Heater Kit							Air Conditioner						
	Heater Kit				Air Conditioner			Heater Kit			Air Conditioner			
	RXJJ-Heater Kit Nominal kW	No. of Sequence Steps	Rated Heater kW @ 600V	Heater kBTU/Hr @ 600V	Heater Amp @ 600V	Unit Min. Ckt. Ampacity @ 600V	Over Current Protective Device Size Min./Max 600V	Min. Ckt. Ampacity 600V	Max. Fuse Size 600V	Min. Circuit Ampacity 600V	Over Current Protective Device Size Min./Max. 600V	Min./Max. 600V	Min./Max. 600V	Min./Max. 600V
B072YL	No Heat	—	—	—	—	12	15/15	—	—	12	15/15	—	—	
	A15Y	1	14.4	49.13	13.9	20	20/20	18	20	12/0	15/15	0/0	0/0	
	A20Y	1	19.2	65.5	18.8	27	30/30	24	25	12/0	15/15	0/0	0/0	
B072YM	A24Y	1	24	81.88	23.1	32	35/35	29	30	12/0	15/15	0/0	0/0	
	No Heat	—	—	—	—	12	15/15	—	—	12	15/15	—	—	
	A15Y	1	14.4	49.13	13.9	20	20/20	18	20	12/0	15/15	0/0	0/0	
B072YM	A20Y	1	19.2	65.5	18.8	27	30/30	24	25	12/0	15/15	0/0	0/0	
	A24Y	1	24	81.88	23.1	32	35/35	29	30	12/0	15/15	0/0	0/0	

* = For Canadian use only. Uses "ip" fuses for inductive circuit.

+ = Field installed only.

RLKN-B 6 TON [21.1 kW] MODEL

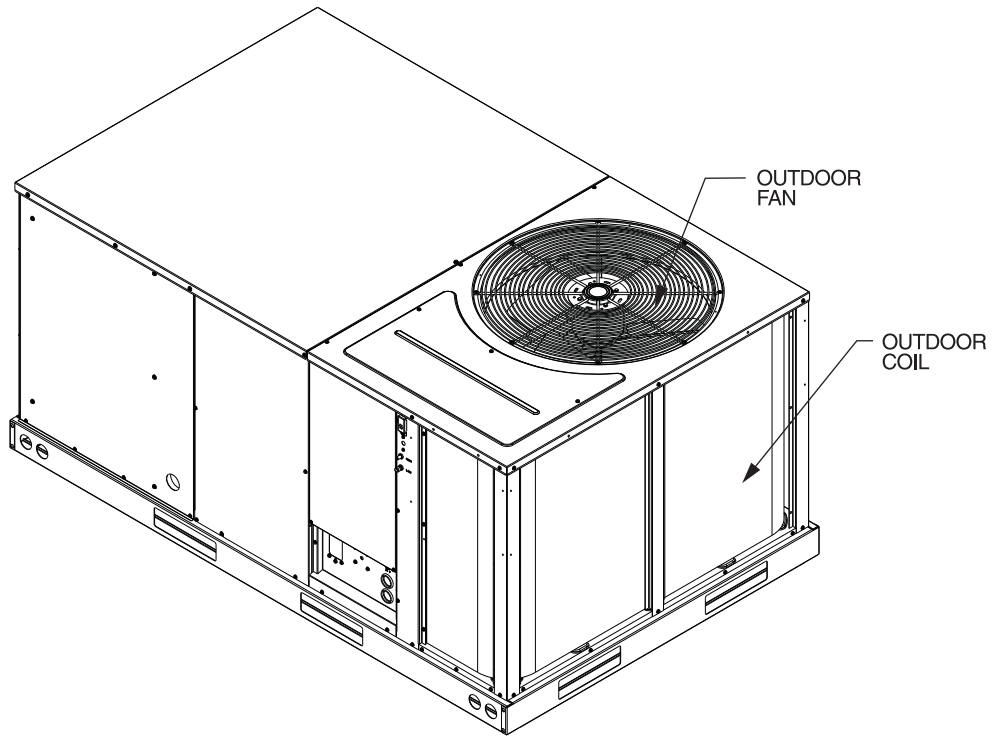

BACK VIEW

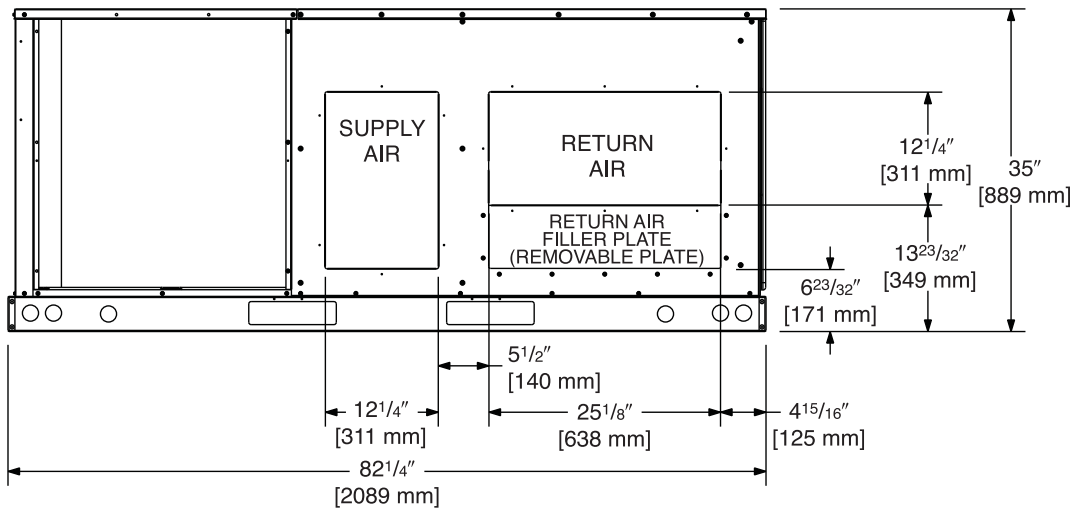

[] Designates Metric Conversions

RLKN-B 6 TON [21.1 kW] MODEL

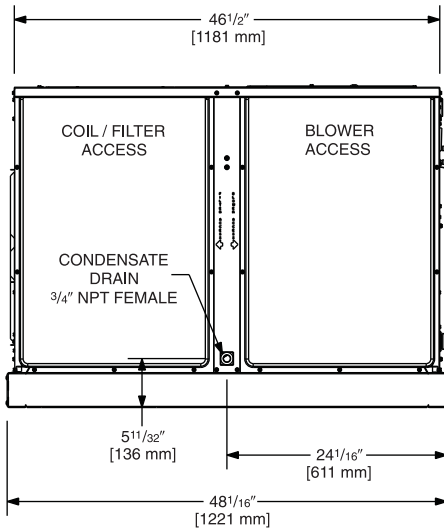

Illustration ST-A1142

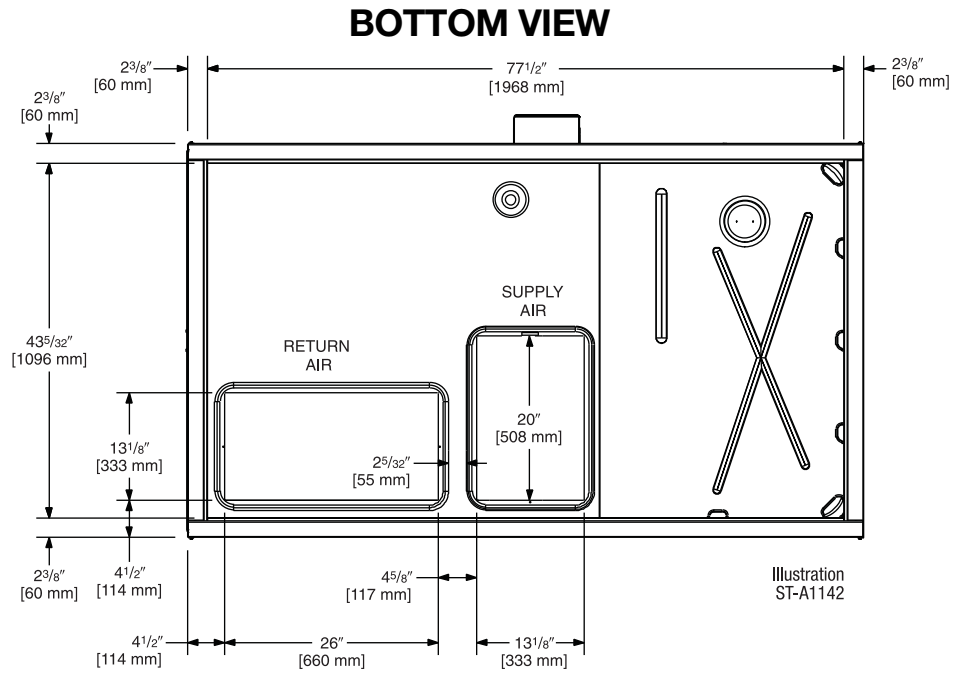

Illustration ST-A1142

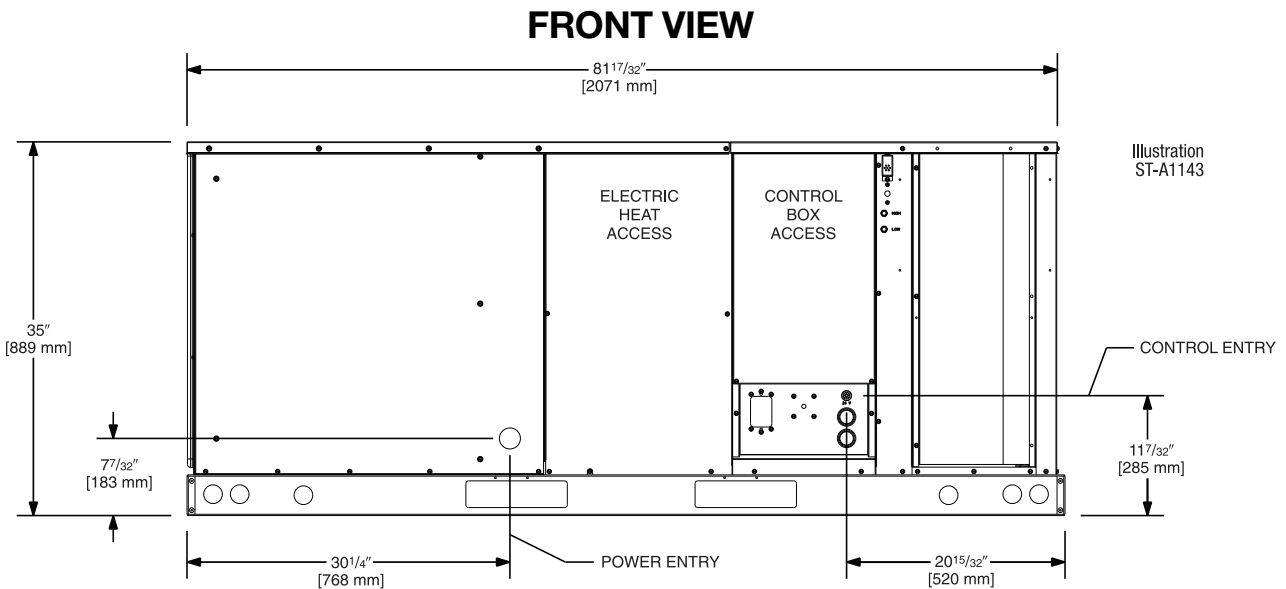

Illustration ST-A1143

[] Designates Metric Conversions

WEIGHTS

Accessory	6 Ton [21.1 kW]	
	Operating lbs [kg]	Operating lbs [kg]
Economizer with Single Enthalpy, Downflow/Sideflow	80 [36]	70 [32]
Power Exhaust	21 [10]	17 [8]
Fresh Air Damper (Manual)	14 [6]	12 [5]
Fresh Air Damper (Motorized)	16 [7]	14 [6]
Roof Curb 14"	92 [42]	88 [40]
Roof Curb 24"	108 [49]	104 [47]
Concentric Diffuser 18" Flush	37 [17]	26 [12]
Concentric Diffuser 20" Flush	54 [24]	42 [19]
Side Discharge Concentric Diffuser RXRN-FA60	—	—
Side Discharge Concentric Diffuser RXRN-FA65	55 [25]	40 [18]

CLEARANCES

The following minimum clearances are recommended for proper unit performance and serviceability.

Recommended Clearance in. [mm]	Location
48 [1219]	A - Front
18 [457]	B - Condenser Coil
*12 [305]	C - Duct Side
36 [914]	D - Evaporator End
60 [1524]	E - Above
*57" [1448 mm] With Economizer	

NOTE: Supply duct may be installed with "0" inch clearance to combustible materials, provided 1" [25.4 mm] minimum. Fiberglass insulation is applied either inside or on the outside of the duct.

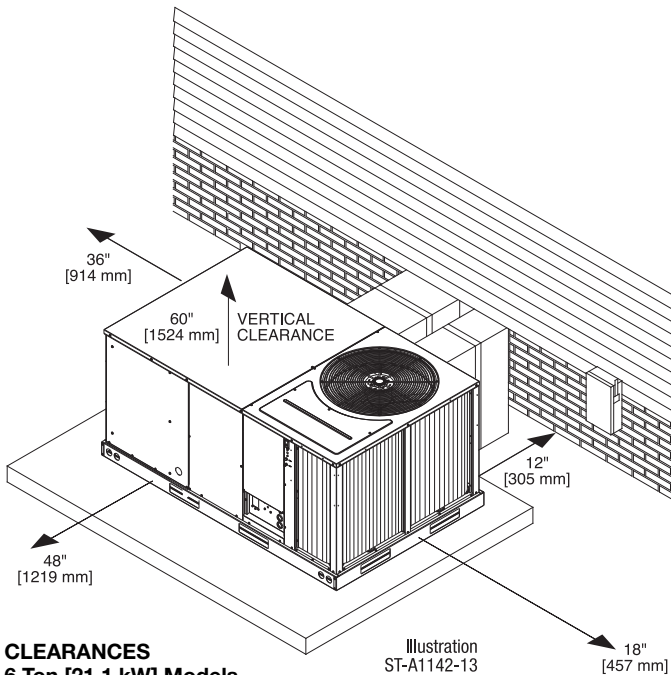

CLEARANCES
6 Ton [21.1 kW] Models

CENTER OF GRAVITY (C.G.)

Capacity Tons [kW]	A in. [mm]	B in. [mm]
6 [21.1]	39 [991]	26 ¹ / ₈ [664]

Capacity Tons [kW]	Corner Weights by Percentage			
	A	B	C	D
6 [21.1]	23%	29%	21%	27%

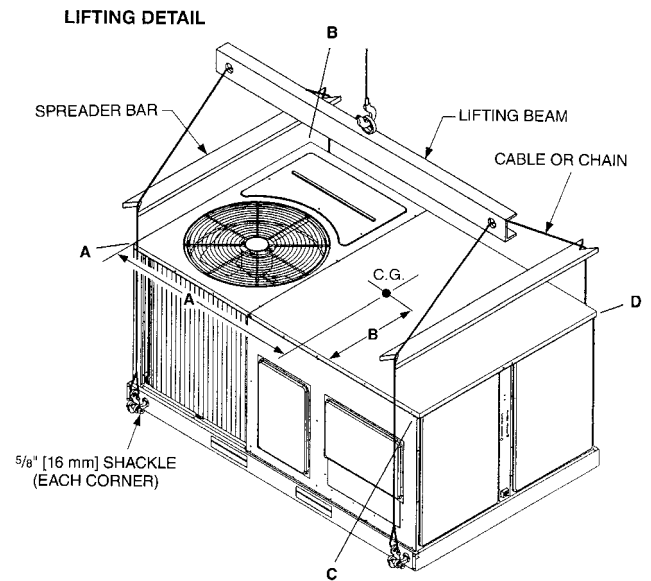

[] Designates Metric Conversions

ACCESSORY EQUIPMENT

Accessory Description	Model Application	Accessory Model No.	Factory Installed
Thermostats	RLKN-B072	See Thermostat Specification Sheet (T11-001)	No
Roofcurb, 14"	RLKN-B072	RXKG-CAD14	No
Roofcurb, 24"	RLKN-B072	RXKG-CAD24	No
Roofcurb adapters	RLKN-B072	RXR-CCCE50	No
Economizer, with single enthalpy	RLKN-B072	AXRD-01CCAM3	Yes
Economizer, with smoke detector	RLKN-B072	AXRD-01CCBM3	Yes
Dual enthalpy kit for economizer	RLKN-B072	RXR-AV02	No
CO ₂ sensor	RLKN-B072	RXR-AR02	No
Power exhaust (C, D, Y voltages)	RLKN-B072	AXR-BGF03 (C,D,Y)	No
Fresh air damper, manual	RLKN-B072	AXR-FCA1	No
Fresh air damper, motorized	RLKN-B072	AXR-JHB1	No
Rectangular-to-round 20" duct adapters for concentric diffuser	RLKN-B072	RXMC-CC04	No
Concentric diffuser 20", step type	RLKN-B072	RXRN-FA65	No
Concentric diffuser 20", flush type	RLKN-B072	RXRN-FA75	No
Louver kit, 3-sided	RLKN-B072	AXR-AAD01B	Yes
Compressor time delay	RLKN-B072	RXMD-B04	No
Low ambient control	RLKN-B072	RXRZ-A04	Yes
Convenience outlet (requires separate power supply)	RLKN-B072	RXR-AN02	Yes
Freeze stat control	RLKN-B072	RXR-AM01	Yes

*Voltage
 C = 208-230 VAC-3PH-60HZ
 D = 460 VAC-3PH-60HZ
 Y = 575 VAC-3PH-60HZ

ROOFCURB ADAPTER

Old Models

**COMMERCIAL PACKAGE UNIT
(6 TON [21.1 kW])**
(-)RCF, (-)REF, (-)RGF131 & 201, RGF150

OLD CURB MODEL

ROOFCURB ADAPTER

NEW MODEL



[] Designates Metric Conversions

(1) SLOPE TYPE (2) FULL PERIMETER TYPE

THERMOSTATS



200-Series *
Programmable



300-Series *
Deluxe
Programmable

400-Series *
Special Applications/
Programmable

Brand	Descriptor (3 Characters)	Series (3 Characters)	System (2 Characters)	Type (2 Characters)
RHC	- TST	213	UN	MS
RHC=Rheem	TST=Thermostat	200=Programmable 300=Deluxe Programmable 400=Special Applications/ Programmable	GE=Gas/Electric UN=Universal (AC/HP/GE) MD=Modulating Furnace DF=Dual Fuel	SS=Single-Stage MS=Multi-Stage

* Photos are representative. Actual models may vary.

For detailed thermostat match-up information,
see specification sheet form number T11-001.

ROOFCURBS (Full Perimeter)

- Rheem's new roofcurb design can be utilized on 3 through 7.5 ton [21.1 kW] models.
- Two available heights (14" [356 mm] and 24" [610 mm]) for ALL models.
- Quick assembly corners for simple and fast assembly
- Opening provided in bottom pan to match the "Thru the Curb" electrical connection opening provided on the unit base pan.
- 2" [51 mm] x 4" [102 mm] Nailers provided.
- Insulating panels provided.
- Sealing gasket (28" [711 mm]) provided with Roofcurb.
- Packaged for easy field assembly.

Roofcurb Model	Height of Curb
RXKG-CAD14	14" [356 mm]
RXKG-CAD24	24" [610 mm]

[] Designates Metric Conversions

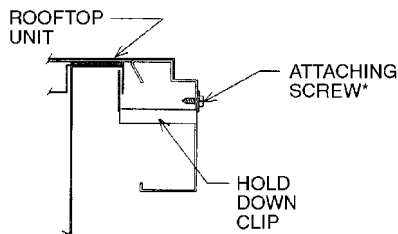
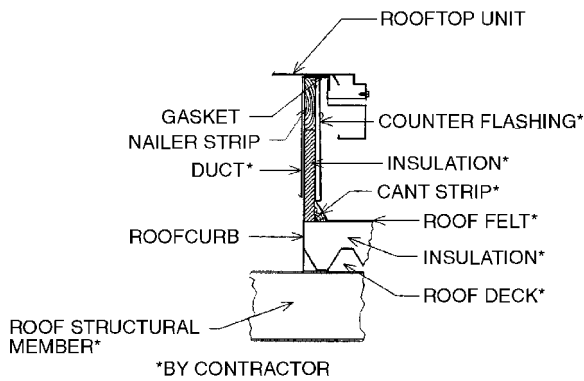

TYPICAL INSTALLATION

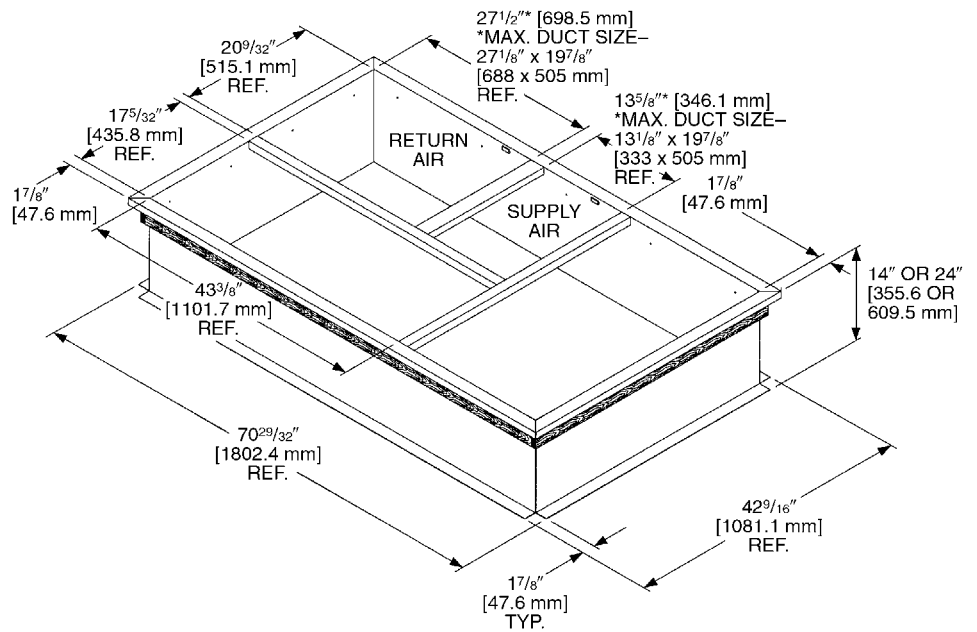
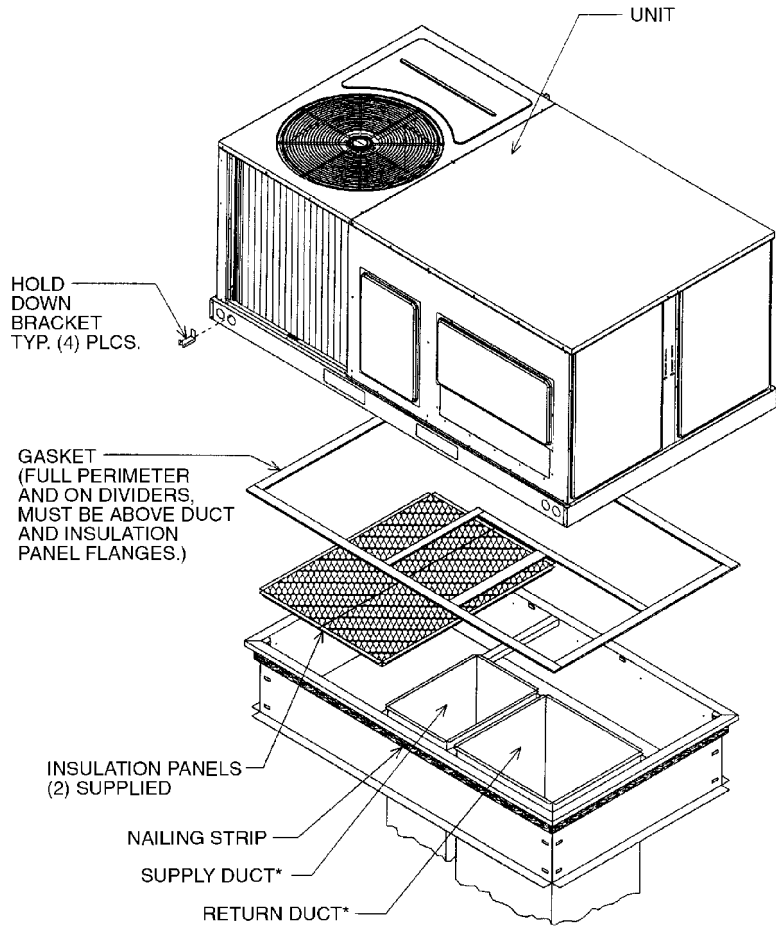

ECONOMIZERS

AXRD-01RCCAM3—3-6 Ton [10.6-21.1 kW] Models
AXRD-01RCCBM3—3-6 Ton [10.6-21.1 kW] Models

RXXR-AV02—3-6 Ton [10.6-21.1 kW] Models

RXXR-AR02—3-6 Ton [10.6-21.1 kW] Models

- Features **Honeywell JADE™** Digital Controls
- Available factory installed or field accessory
- Gear Driven Direct Drive Actuator
- Fully Modulating (0-100%)
- Low Leakage Dampers
- Horizontal or Downflow Applications
- Slip-In Design for Easy Installations
- Plug-In Polarized 12-pin Electrical Connections
- Pre-configuring—No Field Adjustments Necessary
- Standard Barometric Relief Damper Provided
- Single Enthalpy with Dual Enthalpy upgrade kit
- CO₂ Input Sensor Available (field installed)
- Economizer slips in complete for downflow or horizontal duct applications
- Field assembled hood ships with Economizer
- Field installed power exhaust available.

[] Designates Metric Conversions

Single Enthalpy (with Barometric Relief)
Single Enthalpy and Smoke Detector

Dual Enthalpy Kit

Optional CO₂ Sensor

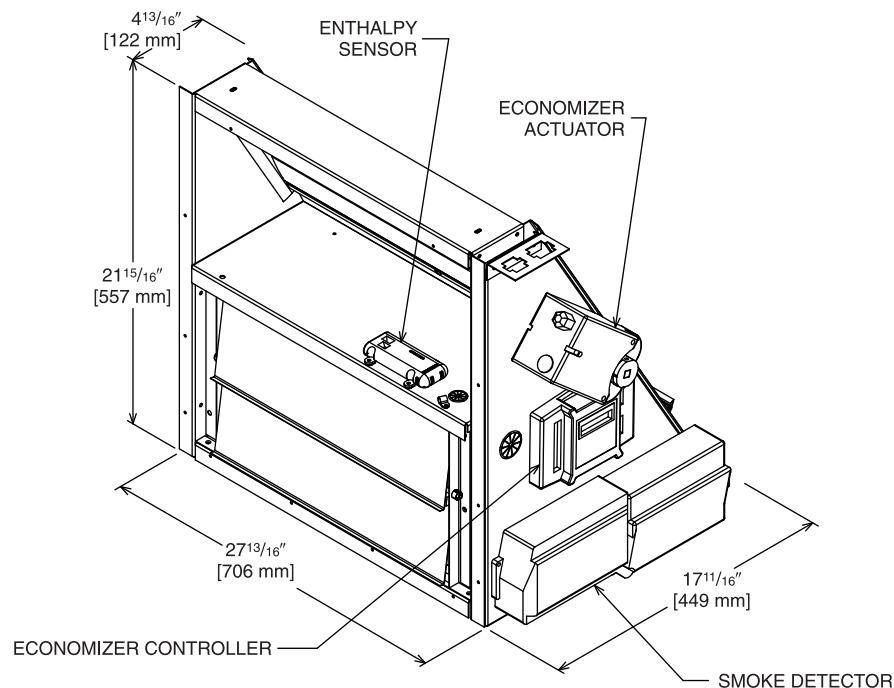
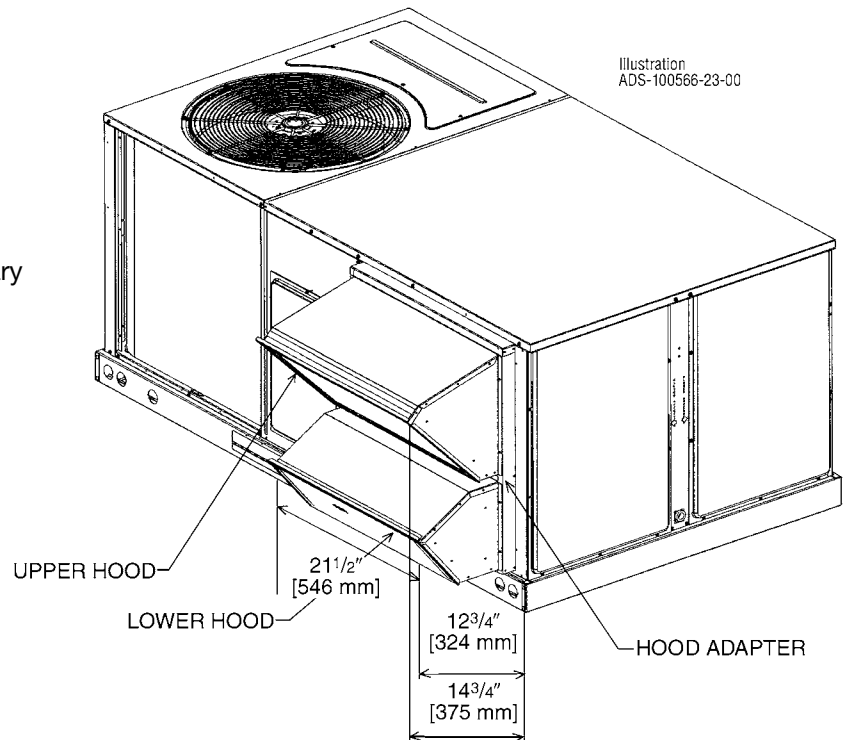

INTEGRAL POWER EXHAUST FOR ECONOMIZER (FIELD INSTALLED ONLY)

AXRX-BGF03—RLKN-B 6 Ton [21.1 kW] Model

- For **Honeywell** Economizer
- Downflow or horizontal applications
- Requires separate 208-230 volt – 1 PH power supply with disconnect or requires separate 460V - 1 PH power supply with disconnect.
- Adjustable switch on economizer, factory preset to energize power exhaust at 95% outside air position
- Polarized plug connects power exhaust relay to economizer

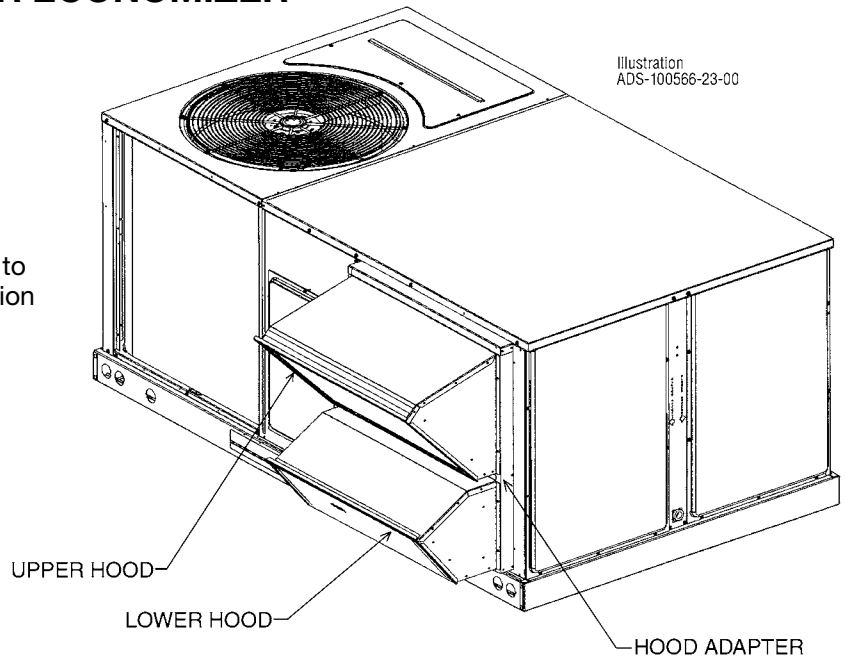

POWER EXHAUST KIT FOR AXRD-01CCAM3 & AXRD-01CCBM3 ECONOMIZERS

Model No.	No. of Fans	Volts	Phase	Watts (ea.)	High Speed		FLA (ea.)	LRA (ea.)
					CFM ①	RPM		
AXRX-BGF03C	1	208/230	1	1000	2500	1725	4.4	23.7
AXRX-BGF03D	1	460	1	800	2370	1620	1.8	4.1
AXRX-BGF03Y ②	1	575	1	800	2370	1620	1.5	3.3
AXRX-BGF04C	1	208/230	1	1000	2500	1725	4.4	23.7
AXRX-BGF04D	1	460	1	800	2370	1620	1.8	4.1
AXRX-BGF04Y ②	1	575	1	800	2370	1620	1.5	3.3

① CFM is at 0" w.c. external static pressure

② Unit includes 575 to 460 Volt step-down transformer

Shipping lbs [kg]	Operating lbs [kg]
70 [32]	67 [30]

RLKN-B 6 Ton [21.1 kW] Models

AXRF-FCA1 (Manual)

AXRF-JHB1 (Motorized)

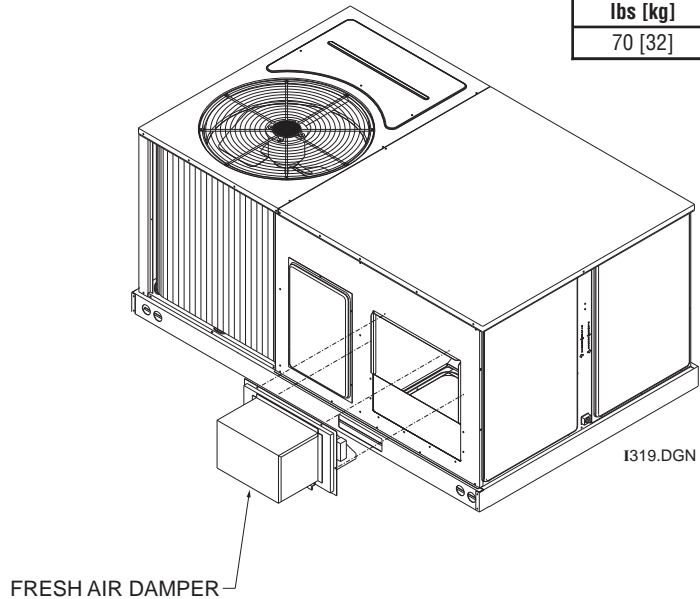

[] Designates Metric Conversions

DUCT ADAPTERS (RLKN-B 6 TON [21.1 kW] MODELS) Rectangular to Round Transitions (Downflow)

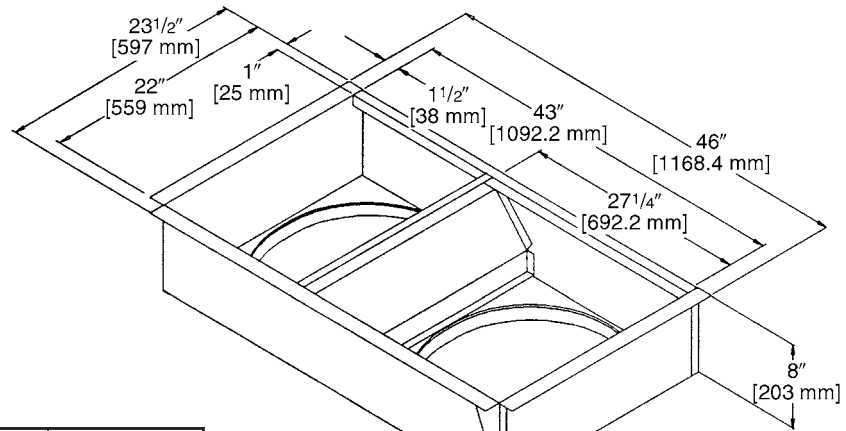

Accessory Model No.	Model Application Tons [kW]	Size in. [mm]
RXMC-CC04	6 [21.1]	20 [508] Round

[] Designates Metric Conversions

PLACE 1/8" [3.18 mm] X 1/2" [12.7 mm] GASKET
 ON UNDERSIDE OF 1 1/2" [38.1 mm] FLANGE

SIDE DISCHARGE CONCENTRIC DIFFUSER

RXRN-FA65 (6 Ton [21.1 kW] Models)

For Use With Duct Adapter (RXMC)

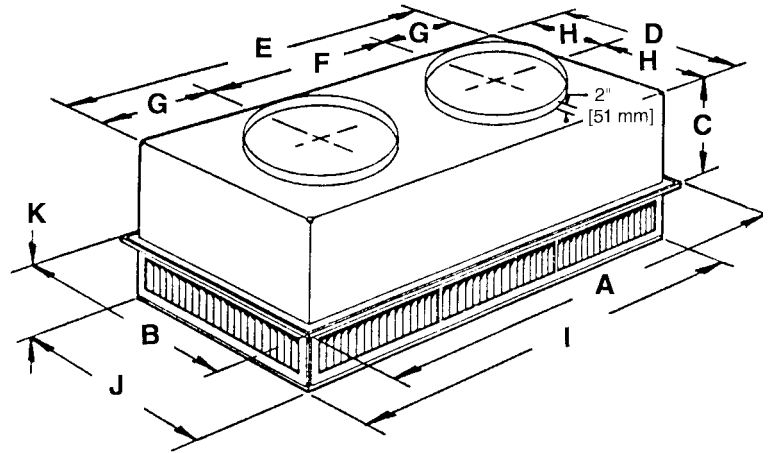

DIMENSIONAL DATA

Model No.	A	B	C	D	E	F	G	H	I	J	K	Duct Size
RXRN-FA65	47 ⁵ / ₈ " [1210 mm]	29 ⁵ / ₈ " [752 mm]	14 ³ / ₈ " [365 mm]	27 ¹ / ₂ " [699 mm]	45 ¹ / ₂ " [1156 mm]	22 ¹ / ₂ " [572 mm]	11 ¹ / ₂ " [292 mm]	13 ³ / ₄ " [349 mm]	45 ¹ / ₂ " [1156 mm]	27 ¹ / ₂ " [699 mm]	8 ¹ / ₈ " [206 mm]	20RD

ENGINEERING DATA

Model No.	CFM [L/s]	Static Pressure	Throw Feet	Neck Vel.	Jet Vel.	Noise Level
RXRN-FA65	2600 [1227]	.17	24-29	669	669	20
	2800 [1321]	.20	25-30	720	720	25
	3000 [1416]	.25	27-33	772	772	25
	3200 [1510]	.31	28-35	823	823	25
	3400 [1605]	.37	30-37	874	874	30

[] Designates Metric Conversions

FLUSH MOUNT CONCENTRIC DIFFUSER

RXRN-FA75 (6 Ton [21.1 kW] Models)

For Use With Duct Adapter (RXMC)

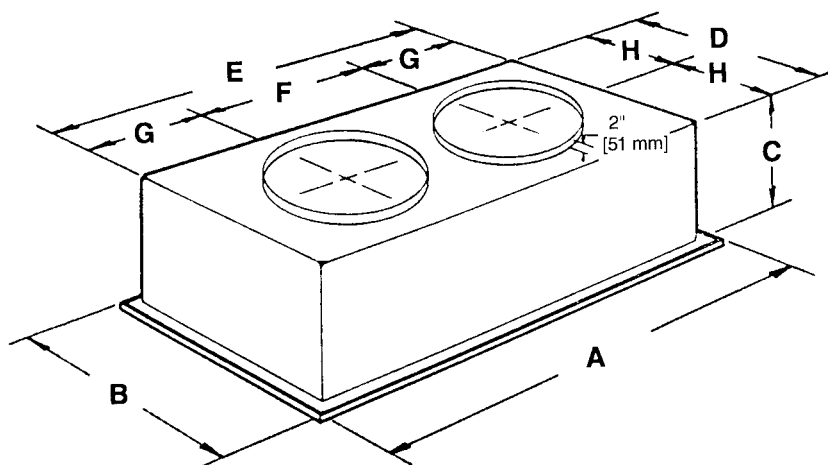

DIMENSIONAL DATA

Model No.	A	B	C	D	E	F	G	H	Duct Size
RXRN-FA75	47 ⁵ / ₈ " [1210 mm]	29 ⁵ / ₈ " [752 mm]	16 ⁵ / ₈ " [422 mm]	27" [686 mm]	45 ¹ / ₂ " [1156 mm]	22 ¹ / ₂ " [572 mm]	11 ¹ / ₄ " [286 mm]	13 ¹ / ₂ " [343 mm]	20RD

ENGINEERING DATA

Model No.	CFM [L/s]	Static Pressure	Throw Feet	Neck Vel.	Jet Vel.	Noise Level
RXRN-FA75	2600 [1227]	.17	19-24	663	1294	30
	2800 [1321]	.20	20-28	714	1393	35
	3000 [1416]	.25	21-29	765	1492	35
	3200 [1510]	.31	22-29	816	1592	40
	3400 [1605]	.37	22-30	867	1692	40

[] Designates Metric Conversions

SAMPLE SPECIFICATIONS

Unit shall be completely factory assembled and performance tested to provide the required cooling and heating functions suitable for outdoor installations. Unit shall be UL/cUL listed and rated in accordance to AHRI Standard 210.

Cabinet

Unit casing, base pan and framework shall be manufactured of galvanized sheet metal primed and finished with powder paint capable of withstanding a 1000-hour salt spray test per ASTM B 117. Unit interior cabinet surfaces shall be insulated with a minimum 1/2-inch thick foil faced insulation. Access panels shall be easily removable providing access to the blower, filter, heating compartment, and compressor/control box. Unit base rails shall be provided with fork insertion slots and rigging holes. Condensate drain pan shall be of sloped design to conform to ASHRAE 62. Unit shall be supplied ready for vertical airflow and be easily convertible to horizontal airflow at or before installation.

Compressor(s)

Unit shall be provided with fully hermetic scroll compressor(s) with internally protected safety controls.

Coils

Aluminum Microchannel evaporator and condenser coils. Aluminum lanced fins thermally bonded to aluminum multi-port flat tube design. Leak tested using helium mass spectrometry.

Condenser Fan

A single direct drive propeller fan shall discharge air vertically upward. The fan motor shall be permanently lubricated and have built-in overload protection.

Evaporator Blower

A single, double inlet, centrifugal wheel shall rotate in permanently lubricated ball bearings. The wheel shall be made from steel with corrosion resistant finish and shall be statically and dynamically balanced.

ACCESSORIES

ROOF CURB

Curb shall be full perimeter type, complying with the standards of the National Roofing Contractors Association. Design shall provide for drop-in of supply and return ducts prior to setting unit, and include an insulating panel for the rest of the curb area.

Economizer

Economizer shall be completely assembled for field installation. Unit shall include all controls and dampers including the barometric relief damper.

Manual Fresh Air Damper

Damper shall consist of damper and rainhood which is manually preset to admit up to 35% of outside air for field installation.

Motorized Fresh Air Damper

Damper shall consist of motor, damper, and rainhood which can admit up to 35% of outside air for field installation.

Electric Heat Kits

Electric heat kits shall be available in a wide range of capacity with branch circuit fusing allowing single point wiring. Kits shall be UL/cUL approved. Each kit shall be offered as a field or factory installed option.

Pressure Controls

High and low pressure controls shall be included for field or factory installation.

Low Ambient Control

Low ambient control shall be provided to cycle the condenser fan in response to condensing pressure and allow operation to 0 degrees F. The option shall be field or factory installed.

Louver Panel Kits

Field or factory installed louver kits shall be provided for condenser coil protection against hail or flying debris.

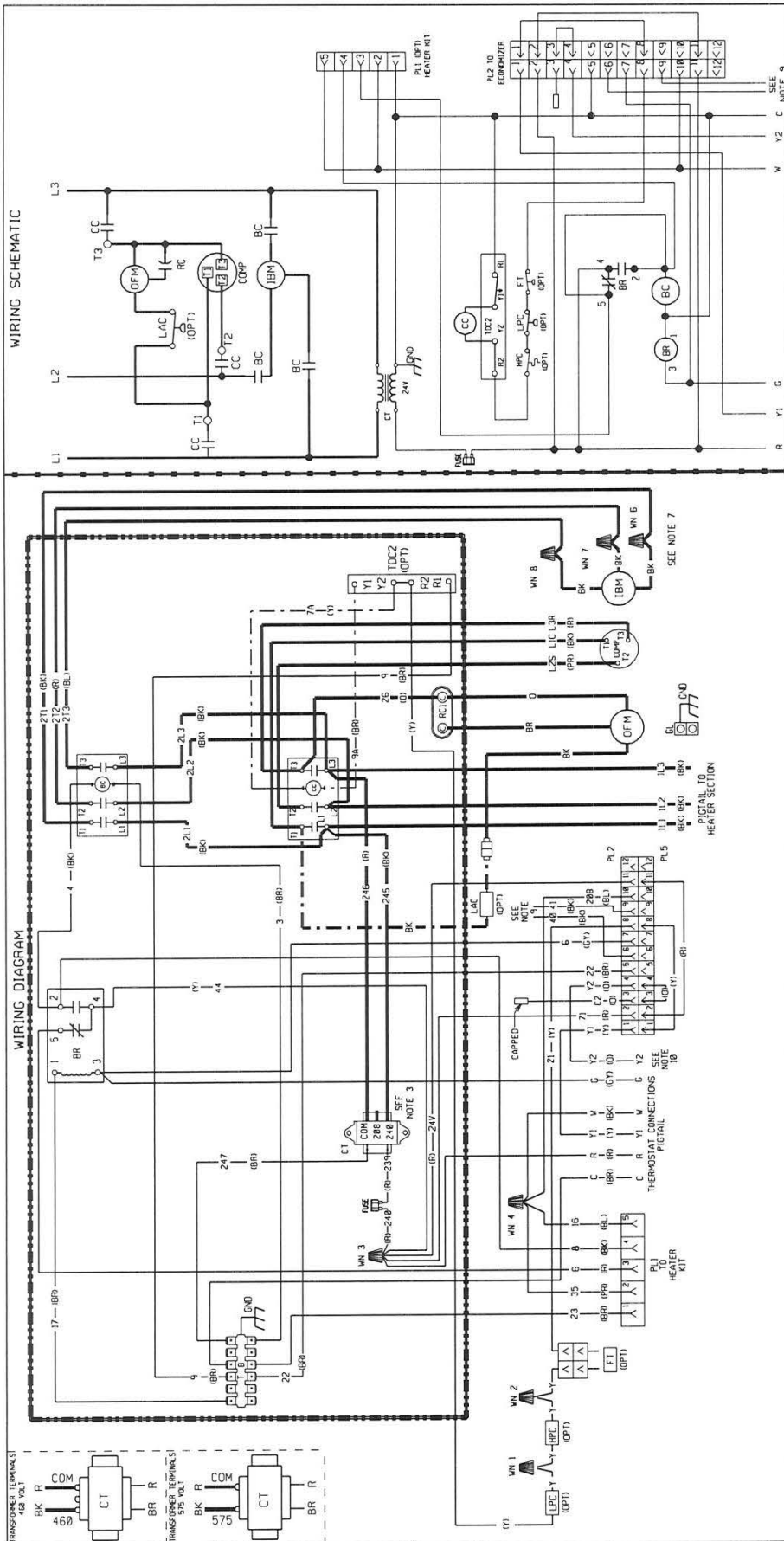

WIRING SCHEMATIC

WIRING DIAGRAM

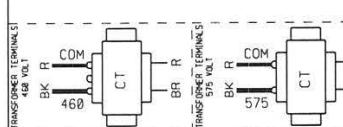

COMPONENT CODE	WIRE COLOR CODE
BC	BK
BR	BR
CC	BL
CCMP	G
CT	GY
FT	ORANGE
GL	BROWN
GND	BL
HPCS	GREEN
IBM	R
LAC	W
LPC	R
LPC	W
OPM	Y
OUTDOOR FAN MOTOR	
RL	
RUM CAPACITOR	
TERMINAL BLOCK (LOW VOLTAGE)	
TDC	
WN	

WIRING INFORMATION
LINE VOLTAGE
-FACTORY STANDARD
-FACTORY OPTION
-FIELD INSTALLED
LOW VOLTAGE
-FACTORY STANDARD
-FIELD INSTALLED
REPLACEMENT WIRE
-MUST BE THE SAME SIZE AND TYPE OF INSULATION AS ORIGINAL (105 C. MIN.)
WARNING
-CABINET MUST BE PERMANENTLY GROUNDED AND CONFORM TO I.E.C., N.E.C., C.E.C. NATIONAL WIRING REGULATIONS, AND LOCAL CODES AS APPLICABLE.

NOTES:

- CONNECTORS SUITABLE FOR USE WITH COPPER CONDUCTORS ONLY. COMPRESSOR MOTOR THERMALLY PROTECTED, ALL 3 PHASE MODELS ARE PROTECTED UNDER PRIMARY SINGLE PHASE CONNECTIONS.
- MOVE BLACK WIRE TO 288 VOLT TAP FOR 288 VOLT APPLICATION. SEE INSET FOR OTHER VOLTAGES.
- SUPPLY TO PICTURE WIRE. CONNECT FIELD WIRE TO FACTORY LOW VOLTAGE CIRCUIT IS N.E.C. CLASS 2 WITH A CLASS 2 TRANSFORMER, 24V/50/60 HZ SUPPLIED.
- FUSING IN GROUNDED RAIN TIGHT CONDUIT TO 60 HZ FUSED DISCONNECT.
- MOTOR FACTORY WIRE FOR CORRECT SPEED.
- CLASSIFICATION LABEL ON UNIT FUSE BOX FOR FUSE SIZING AND WIRES FROM PL2 16 & 9; GO TO THE MIXED AIR SENSOR ON THE OPTIONAL ECONOMIZER.
- 12 IS USED ONLY FOR THE OPTIONAL ECONOMIZER.

ELECTRICAL WIRING DIAGRAM
208/230/460/575V, 3 PHASE 60 HZ.
200/220/380/415V, 3 PHASE, 50 HZ
BELT DRIVE

PACKAGE AIR CONDITIONER

DR. BY: KDF
APP. BY: MEF
DATE: 04-02-14
DWG. NO.: 90-23597-34
REV: 00

BEFORE PURCHASING THIS APPLIANCE, READ IMPORTANT ENERGY COST AND EFFICIENCY INFORMATION AVAILABLE FROM YOUR RETAILER.

GENERAL TERMS OF LIMITED WARRANTY*

Rheem will furnish a replacement for any part of this product which fails in normal use and service within the applicable periods stated, in accordance with the terms of the limited warranty.

***For complete details of the Limited and Conditional Warranties, including applicable terms and conditions, contact your local contractor or the Manufacturer for a copy of the product warranty certificate.**

Compressor	
3 Phase, Commercial Applications.....	Five (5) Years
Parts	
3 Phase, Commercial Applications.....	One (1) Year



The new degree of comfort.™

In keeping with its policy of continuous progress and product improvement, Rheem reserves the right to make changes without notice.

Rheem Heating, Cooling & Water Heating • P.O. Box 17010
Fort Smith, Arkansas 72917 • www.rheem.com

Rheem Canada Ltd./Ltée • 125 Edgeware Road, Unit 1
Brampton, Ontario • L6Y 0P5



INTEGRATED AIR & WATER

PRINTED IN U.S.A. 1/15 QG FORM NO. S11-973