

# INSTALLATION INSTRUCTIONS

## FOR PACKAGE AIR CONDITIONERS FEATURING INDUSTRY STANDARD R410A REFRIGERANT ~~R-410A~~ RLKL 6 TON

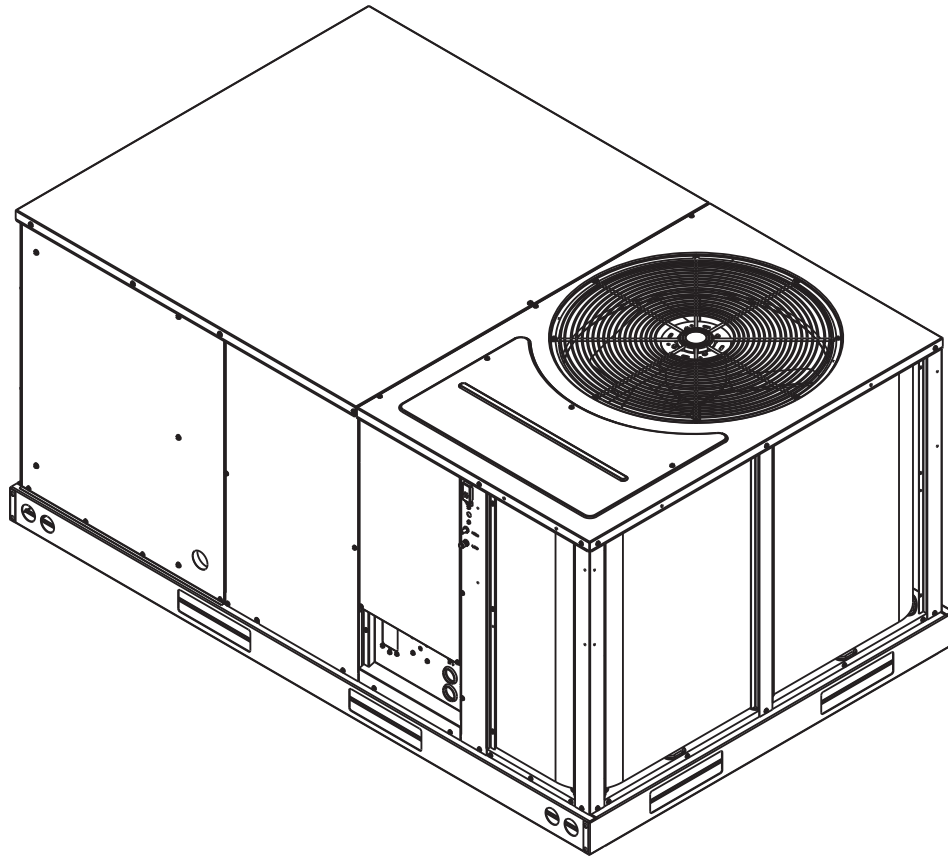

**RECOGNIZE THIS SYMBOL AS AN INDICATION OF IMPORTANT SAFETY INFORMATION!**

### **▲ WARNING**

THESE INSTRUCTIONS ARE INTENDED AS AN AID TO QUALIFIED, LICENSED SERVICE PERSONNEL FOR PROPER INSTALLATION, ADJUSTMENT AND OPERATION OF THIS UNIT. READ THESE INSTRUCTIONS THOROUGHLY BEFORE ATTEMPTING INSTALLATION OR OPERATION. FAILURE TO FOLLOW THESE INSTRUCTIONS MAY RESULT IN IMPROPER INSTALLATION, ADJUSTMENT, SERVICE OR MAINTENANCE POSSIBLY RESULTING IN FIRE, ELECTRICAL SHOCK, PROPERTY DAMAGE, PERSONAL INJURY OR DEATH.



Accredited by the RVA



**ISO 9001:2008**

Certificate Number: 30164

**DO NOT DESTROY THIS MANUAL**

**PLEASE READ CAREFULLY AND KEEP IN A SAFE PLACE FOR FUTURE REFERENCE BY A SERVICEMAN**



[ ] INDICATES METRIC CONVERSIONS

92-23577-100-02  
SUPERSEDES 92-23577-100-01

# I. TABLE OF CONTENTS

|  |     |
|--|-----|
| I. Table of Contents .....   | 2   |
| II. Introduction .....   | 3   |
| III. Checking Product Received .....                                       | 3   |
| IV. Equipment Protection .....   | 3   |
| V. Specifications .....  | 3   |
| A. General .....   | 3   |
| B. Major Components .....  | 4   |
| C. R410A Refrigerant .....   | 4   |
| 1. Specification of R-410A .....   | 4   |
| 2. Quick Reference Guide for R-410A .....                                  | 4   |
| 3. Evaporator Coil / TXV .....   | 4   |
| 4. Tools Required For Installing & Servicing<br>R-410A Models .....        | 4   |
| Unit Dimensions .....  | 5   |
| VI. General Data .....   | 8-9 |
| VIII. Installation .....   | 10  |
| A. General .....   | 10  |
| 1. Pre-Installation Check Points .....                                     | 10  |
| 2. Location .....  | 10  |
| B. Outside Slab Installation .....   | 10  |
| C. Clearances .....  | 12  |
| D. Rooftop Installation .....  | 12  |
| IX. Ductwork .....   | 12  |
| X. Filters .....   | 13  |
| XI. Conversion Procedure .....   | 13  |
| XII. Condensate Drain .....  | 13  |
| XIII. Electrical Wiring .....  | 14  |
| A. Power Wiring .....  | 14  |
| B. Special Instructions for Power<br>Wiring with Aluminum Conductors ..... | 14  |
| C. Control Wiring .....  | 15  |
| D. Internal Wiring .....   | 15  |
| E. Grounding .....   | 15  |
| F. Thermostat .....  | 16  |
| XIV. Electrical Data .....   | 16  |
| XV. Electric Heater Kits .....   | 17  |
| XVI. Airflow Performance .....   | 18  |
| XVII. Indoor Air Flow Data .....   | 19  |
| XVIII. Crankcase Heat .....  | 19  |
| XIX. Pre-Start Check .....   | 19  |
| XX. Startup .....  | 19  |
| XXI. Operation .....   | 20  |
| XXII. Auxiliary Heat .....   | 20  |
| XXIII. Replacement Parts .....   | 20  |
| XXIV. Charge Information .....   | 20  |
| XXV. Troubleshooting .....   | 20  |
| XXVI. Wiring Diagrams .....  | 20  |

## **▲ WARNING**

**PROPOSITION 65: THIS APPLIANCE CONTAINS FIBERGLASS INSULATION. RESPIRABLE PARTICLES OF FIBERGLASS ARE KNOWN TO THE STATE OF CALIFORNIA TO CAUSE CANCER.**

## **▲ WARNING**

**THE MANUFACTURER'S WARRANTY DOES NOT COVER ANY DAMAGE OR DEFECT TO THE AIR CONDITIONER CAUSED BY THE ATTACHMENT OR USE OF ANY COMPONENTS, ACCESSORIES OR DEVICES (OTHER THAN THOSE AUTHORIZED BY THE MANUFACTURER) INTO, ONTO OR IN CONJUNCTION WITH THE AIR CONDITIONER. YOU SHOULD BE AWARE THAT THE USE OF UNAUTHORIZED COMPONENTS, ACCESSORIES OR DEVICES MAY ADVERSELY AFFECT THE OPERATION OF THE AIR CONDITIONER AND MAY ALSO ENDANGER LIFE AND PROPERTY. THE MANUFACTURER DISCLAIMS ANY RESPONSIBILITY FOR SUCH LOSS OR INJURY RESULTING FROM THE USE OF SUCH UNAUTHORIZED COMPONENTS, ACCESSORIES OR DEVICES.**

## **▲ WARNING**

**DISCONNECT ALL POWER TO THE UNIT BEFORE STARTING MAINTENANCE. FAILURE TO DO SO CAN RESULT IN SEVERE ELECTRICAL SHOCK OR DEATH.**

## **II. INTRODUCTION**

This booklet contains the installation and operating instructions for your self-contained air conditioner. There are a few precautions that should be taken to derive maximum satisfaction from it. Improper installation can result in unsatisfactory operation or dangerous conditions.

Read this booklet and any instructions packaged with separate equipment required to make up the system prior to installation. Give this booklet to the owner and explain its provisions. The owner should retain this booklet for future reference.

## **III. CHECKING PRODUCT RECEIVED**

Upon receiving the unit, inspect it for any damage from shipment. Claims for damage, either shipping or concealed, should be filed immediately with the shipping company. Check the unit model number, electrical characteristics, and accessories to determine if they are correct.

## **IV. EQUIPMENT PROTECTION FROM THE ENVIRONMENT**

The metal parts of this unit may be subject to rust or deterioration in adverse environmental conditions. This oxidation could shorten the equipment's useful life. Salt spray, fog or mist in seacoast areas, sulphur or chlorine from lawn watering systems, and various chemical contaminants from industries such as paper mills and petroleum refineries are especially corrosive.

**If the unit is to be installed in an area where contaminants are likely to be a problem, special attention should be given to the equipment location and exposure.**

1. Avoid having lawn sprinkler heads spray direction on the unit cabinet.
2. In coastal areas, locate the unit on the side of the building away from the waterfront.
3. Shielding provided by a fence or shrubs may give some protection.

**Regular maintenance will reduce the buildup of contaminants and help to protect the unit's finish.**

1. Frequent washing of the cabinet, fan blade and coil with fresh water will remove most of the salt or other contaminants that build up on the unit.
2. Regular cleaning and waxing of the cabinet with a good automobile polish will provide some protection.
3. A good liquid cleaner may be used several times a year to remove matter that will not wash off with water.

Several different types of protective coatings are offered in some areas. These coatings may provide some benefit, but the effectiveness of such coating materials cannot be verified by the equipment manufacturer.

**The best protection is frequent cleaning, maintenance and minimal exposure to contaminants.**

## **V. SPECIFICATIONS**

### **A. GENERAL**

The Combination Electric Cooling Rooftop with optional electric heat is available in cooling capacity of 6 nominal tons. Units are convertible from bottom supply and return to side supply and return by relocation of supply and return air access panels. See cover installation detail.

The units are weatherized for mounting outside of the building.

## B. MAJOR COMPONENTS

The unit includes a hermetically-sealed refrigerating system (consisting of a scroll compressor, condenser coil, evaporator coil with thermostatic expansion valve), a circulation air blower, a condenser fan, and all necessary internal electrical wiring. The cooling system of these units is factory-evacuated, charged with R-410A refrigerant and performance tested. Refrigerant amount and type are indicated on rating plate.

## C. R-410A REFRIGERANT

All units are factory charged with R-410A refrigerant.

1. Specification of R-410A:

**Application:** R-410A is not a drop-in replacement for R-22; equipment designs must accommodate its higher pressures. It cannot be retrofitted into R-22 units.

**Pressure:** The pressure of R-410A is approximately 60% (1.6 times) greater than R-22. Recovery and recycle equipment, pumps, hoses and the like need to have design pressure ratings appropriate for R-410A. *Manifold sets need to range up to 800 psig high-side and 250 psig low-side with a 550 psig low-side retard. Hoses need to have a service pressure rating of 800 psig. Recovery cylinders need to have a 400 psig service pressure rating. DOT 4BA400 or DOT BW400.*

**Combustibility:** At pressures above 1 atmosphere, mixture of R-410A and air can become combustible. R-410A and air should never be mixed in tanks or supply lines, or be allowed to accumulate in storage tanks. Leak checking should never be done with a mixture of R-410A and air. Leak checking can be performed safely with nitrogen or a mixture of R-410A and nitrogen.

2. Quick Reference Guide For R-410A

- R-410A refrigerant operates at approximately 60% higher pressure (1.6 times) than R-22. Ensure that servicing equipment is designed to operate with R-410A.
- R-410A refrigerant cylinders are pink.
- R-410A, as with other HFC's is only compatible with POE oils.
- Vacuum pumps will not remove moisture from POE oil.
- R-410A systems are to be charged with liquid refrigerants. Prior to March 1999, R-410A refrigerant cylinders had a dip tube. These cylinders should be kept upright for equipment charging. Post March 1999 cylinders do not have a dip tube and should be inverted to ensure liquid charging of the equipment.
- Do not install a suction line filter drier in the liquid line.
- A liquid line filter drier is standard on every unit.
- Desiccant (drying agent) must be compatible for POE oils and R-410A

3. Evaporator Coil / TXV

The thermostatic expansion valve is specifically designed to operate with R-410A.

4. Tools Required For Installing & Servicing R-410A Models

Manifold Sets:

- Up to 800 PSIG High side
- Up to 250 PSIG Low Side
- 550 PSIG Low Side Retard

Manifold Hoses:

- Service Pressure Rating of 800 PSIG

Recovery Cylinders:

- 400 PSIG Pressure Rating
- Dept. of Transportation 4BA400 or BW400

### CAUTION

R-410A systems operate at higher pressures than R-22 systems. Do not use R-22 service equipment or components on R-410A equipment.

**FIGURE 1**  
6 TON MODEL

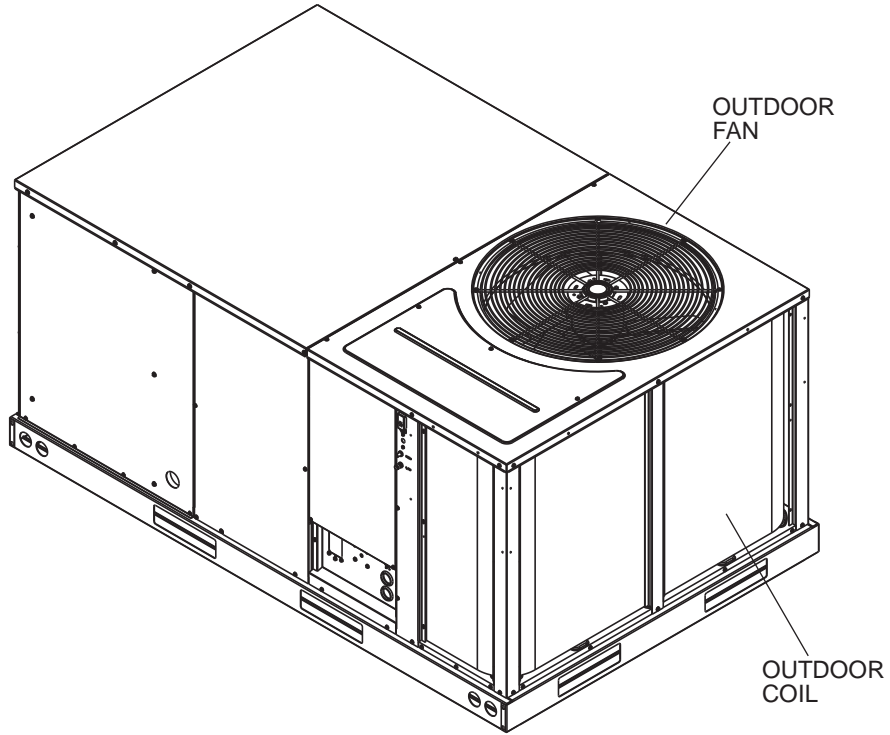

**FIGURE 2**  
BACK VIEW

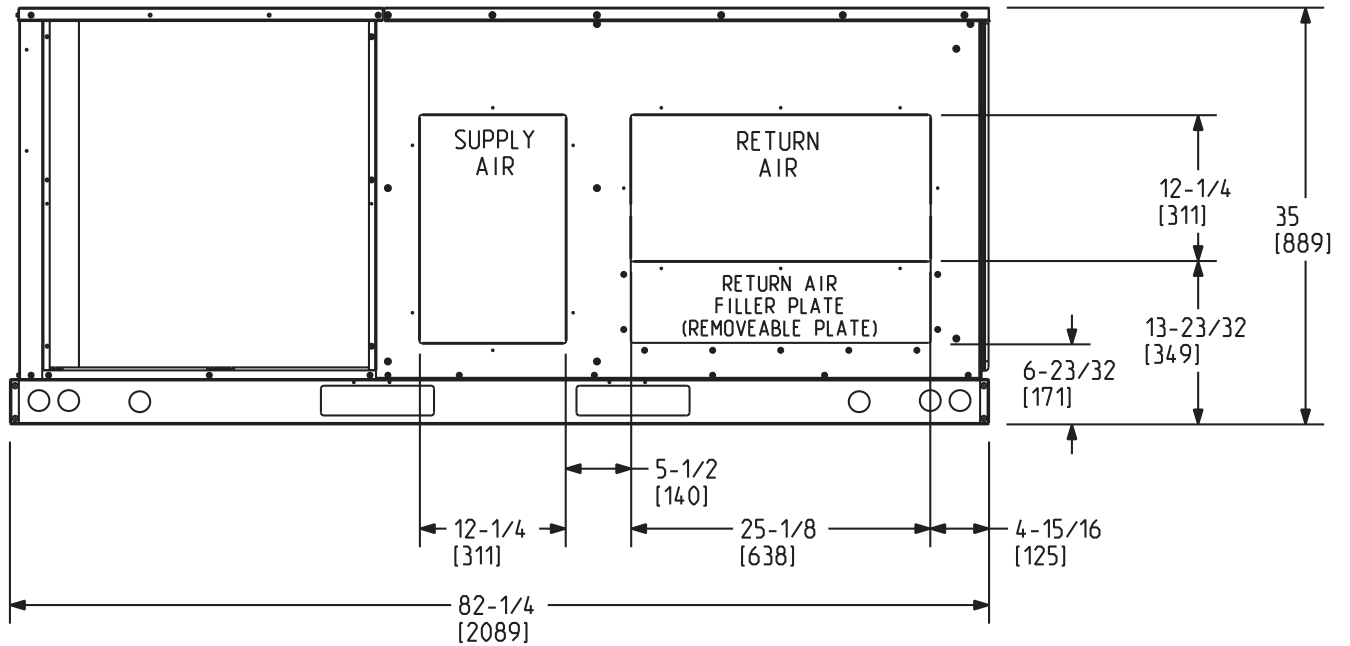

[ ] Designates Metric Conversion

ST-A1143

**FIGURE 3**  
SIDE VIEW

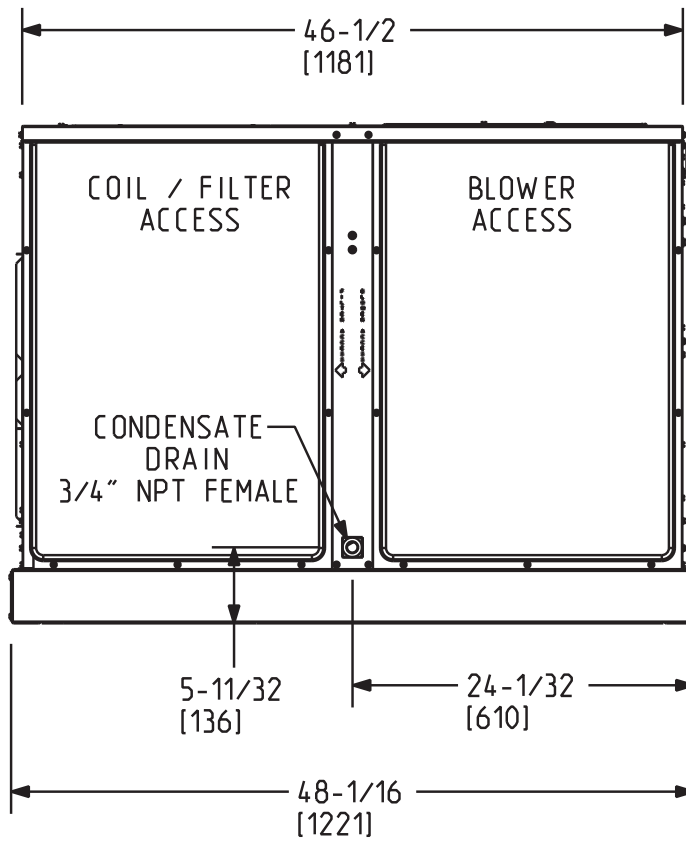

[ ] Designates Metric Conversion

ST-A1143

**FIGURE 4**  
FRONT VIEW

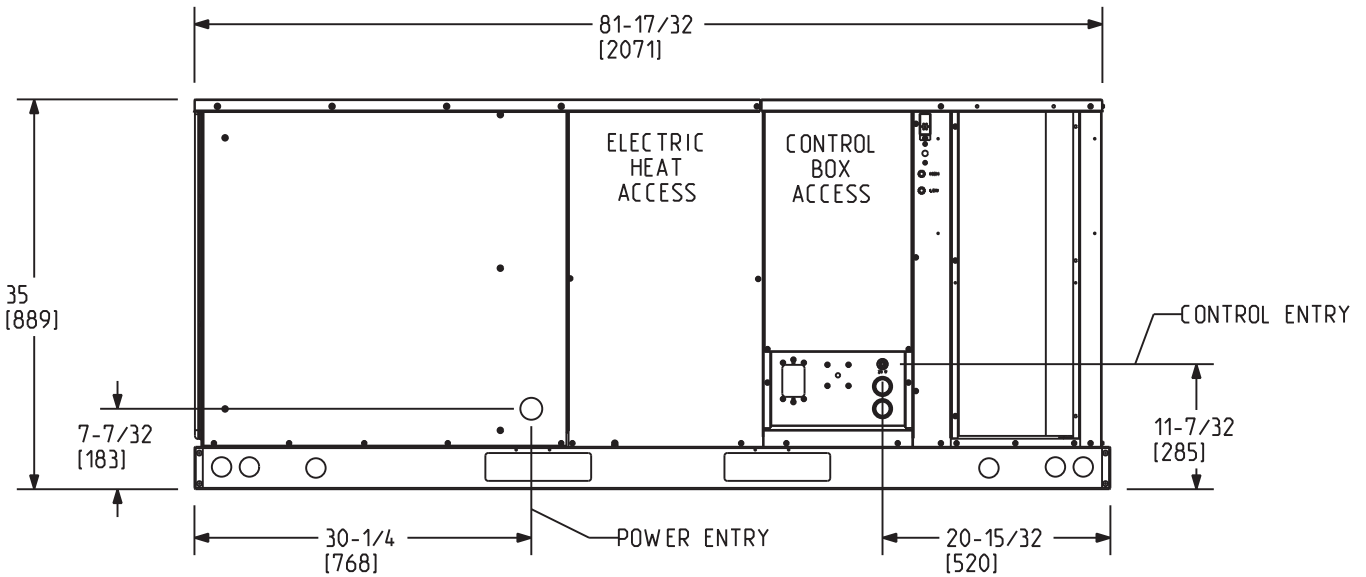

[ ] Designates Metric Conversion

ST-A1143

**FIGURE 5**  
**BOTTOM VIEW**

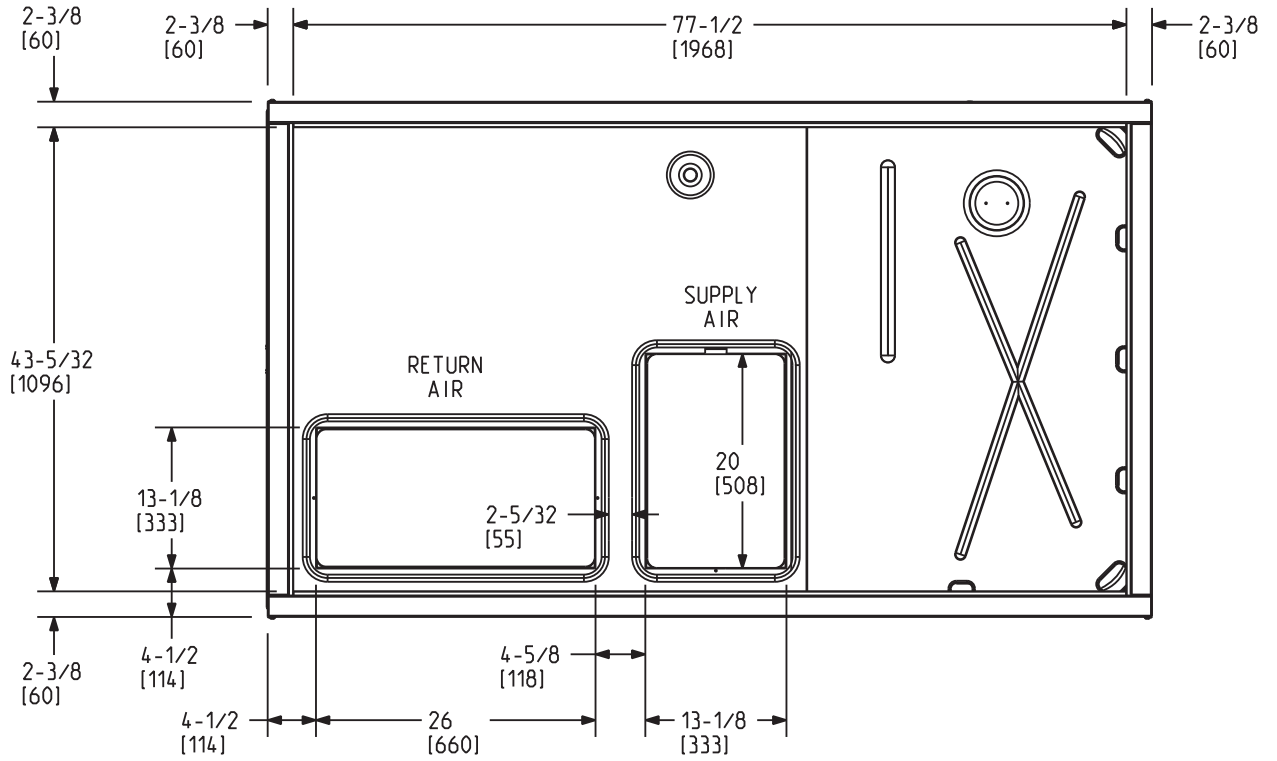

[ ] Designates Metric Conversion

ST-A1143

# VI. GENERAL DATA - RLKL MODELS

## NOMINAL SIZES 6 TON [21.1 kW]

| Model RLKL- Series                           | B072CL                  | B072CM                  | B072DL                  | B072DM                  |
|--|-------------------------|-------------------------|-------------------------|-------------------------|
| <b>Cooling Performance<sup>1</sup></b>       |                         |                         |                         | <b>Continued -&gt;</b>  |
| Gross Cooling Capacity Btu [kW]              | 73,000 [21.39]          | 73,000 [21.39]          | 73,000 [21.39]          | 73,000 [21.39]          |
| EER/SEER <sup>2</sup>                        | 11.2/NA                 | 11.2/NA                 | 11.2/NA                 | 11.2/NA                 |
| Nominal CFM/AHRI Rated CFM [L/s]             | 2400/2050 [1133/967]    | 2400/2050 [1133/967]    | 2400/2050 [1133/967]    | 2400/2050 [1133/967]    |
| AHRI Net Cooling Capacity Btu [kW]           | 70,000 [2051]           | 70,000 [2051]           | 70,000 [2051]           | 70,000 [2051]           |
| Net Sensible Capacity Btu [kW]               | 49,700 [14.56]          | 49,700 [14.56]          | 49,700 [14.56]          | 49,700 [14.56]          |
| Net Latent Capacity Btu [kW]                 | 20,300 [5.95]           | 20,300 [5.95]           | 20,300 [5.95]           | 20,300 [5.95]           |
| IEER <sup>3</sup>                            | 11.7                    | 11.7                    | 11.7                    | 11.7                    |
| Net System Power kW                          | 6.21                    | 6.21                    | 6.21                    | 6.21                    |
| <b>Compressor</b>                            |                         |                         |                         |                         |
| No./Type                                     | 1/Scroll                | 1/Scroll                | 1/Scroll                | 1/Scroll                |
| <b>Outdoor Sound Rating (dB)<sup>5</sup></b> | 83                      | 83                      | 83                      | 83                      |
| <b>Outdoor Coil - Fin Type</b>               | Louvered                | Louvered                | Louvered                | Louvered                |
| Tube Type                                    | Rifled                  | Rifled                  | Rifled                  | Rifled                  |
| Tube Size in. [mm] OD                        | 0.375 [9.5]             | 0.375 [9.5]             | 0.375 [9.5]             | 0.375 [9.5]             |
| Face Area sq. ft. [sq. m]                    | 16.56 [1.54]            | 16.56 [1.54]            | 16.56 [1.54]            | 16.56 [1.54]            |
| Rows / FPI [FPcm]                            | 2 / 22 [9]              | 2 / 22 [9]              | 2 / 22 [9]              | 2 / 22 [9]              |
| <b>Indoor Coil - Fin Type</b>                | Corrugated              | Corrugated              | Corrugated              | Corrugated              |
| Tube Type                                    | Rifled                  | Rifled                  | Rifled                  | Rifled                  |
| Tube Size in. [mm]                           | 0.375 [9.5]             | 0.375 [9.5]             | 0.375 [9.5]             | 0.375 [9.5]             |
| Face Area sq. ft. [sq. m]                    | 6.5 [0.6]               | 6.5 [0.6]               | 6.5 [0.6]               | 6.5 [0.6]               |
| Rows / FPI [FPcm]                            | 4 / 12 [5]              | 4 / 12 [5]              | 4 / 12 [5]              | 4 / 12 [5]              |
| Refrigerant Control                          | TX Valves               | TX Valves               | TX Valves               | TX Valves               |
| Drain Connection No./Size in. [mm]           | 1/1 [25.4]              | 1/1 [25.4]              | 1/1 [25.4]              | 1/1 [25.4]              |
| <b>Outdoor Fan - Type</b>                    | Propeller               | Propeller               | Propeller               | Propeller               |
| No. Used/Diameter in. [mm]                   | 1/24 [609.6]            | 1/24 [609.6]            | 1/24 [609.6]            | 1/24 [609.6]            |
| Drive Type/No. Speeds                        | Direct/1                | Direct/1                | Direct/1                | Direct/1                |
| CFM [L/s]                                    | 4000 [1888]             | 4000 [1888]             | 4000 [1888]             | 4000 [1888]             |
| No. Motors/HP                                | 1 at 1/3 HP             | 1 at 1/3 HP             | 1 at 1/3 HP             | 1 at 1/3 HP             |
| Motor RPM                                    | 1075                    | 1075                    | 1075                    | 1075                    |
| <b>Indoor Fan - Type</b>                     | FC Centrifugal          | FC Centrifugal          | FC Centrifugal          | FC Centrifugal          |
| No. Used/Diameter in. [mm]                   | 1/11x10 [279x254]       | 1/11x10 [279x254]       | 1/11x10 [279x254]       | 1/11x10 [279x254]       |
| Drive Type/No. Speeds                        | Belt/Variable           | Belt/Variable           | Belt/Variable           | Belt/Variable           |
| No. Motors                                   | 1                       | 1                       | 1                       | 1                       |
| Motor HP                                     | 1 1/2                   | 1 1/2                   | 1 1/2                   | 1 1/2                   |
| Motor RPM                                    | 1725                    | 1725                    | 1725                    | 1725                    |
| Motor Frame Size                             | 0                       | 0                       | 0                       | 0                       |
| <b>Filter - Type</b>                         | Disposable              | Disposable              | Disposable              | Disposable              |
| Furnished                                    | Yes                     | Yes                     | Yes                     | Yes                     |
| (NO.) Size Recommended in. [mm x mm x mm]    | (4)2x16x16 [51x406x406] | (4)2x16x16 [51x406x406] | (4)2x16x16 [51x406x406] | (4)2x16x16 [51x406x406] |
| <b>Refrigerant Charge Oz. [g]</b>            | 191 [5415]              | 191 [5415]              | 191 [5415]              | 191 [5415]              |
| <b>Weights</b>                               |                         |                         |                         |                         |
| Net Weight lbs. [kg]                         | 569 [258]               | 569 [258]               | 569 [258]               | 569 [258]               |
| Ship Weight lbs. [kg]                        | 576 [261]               | 576 [261]               | 576 [261]               | 576 [261]               |

[ ] Designates Metric Conversions

### NOTES:

- Cooling Performance is rated at 95° F ambient, 80° F entering dry bulb, 67° F entering wet bulb. Gross capacity does not include the effect of fan motor heat. AHRI capacity is net and includes the effect of fan motor heat. Units are suitable for operation to ±20% of nominal cfm. Units are certified in accordance with the Unitary Air Conditioner Equipment certification program, which is based on AHRI Standard 210/240 or 360.
- EER and/or SEER are rated at AHRI conditions and in accordance with DOE test procedures.
- IEER is rated in accordance with AHRI Standard 210/240 or 340/360.
- Heating Performance limit settings and rating data were established and approved under laboratory test conditions using American National Standard Institute standards. Ratings shown are for elevations up to 2000 feet. For elevations above 2000 feet, ratings should be reduced at the rate of 4% for each 1000 feet above sea level.
- Outdoor Sound Rating shown is tested in accordance with AHRI Standard 270.



# GENERAL DATA - RLKL MODELS

## NOMINAL SIZES 6 TON [21.1 kW]

| Model RLKL- Series                           | B072YL                  | B072YM                  |
|--|-------------------------|-------------------------|
| <b>Cooling Performance<sup>1</sup></b>       |                         |                         |
| Gross Cooling Capacity Btu [kW]              | 73,000 [21.39]          | 73,000 [21.39]          |
| EER/SEER <sup>2</sup>                        | 11.2/NA                 | 11.2/NA                 |
| Nominal CFM/AHRI Rated CFM [L/s]             | 2400/2050 [1133/967]    | 2400/2050 [1133/967]    |
| AHRI Net Cooling Capacity Btu [kW]           | 70,000 [20.51]          | 70,000 [20.51]          |
| Net Sensible Capacity Btu [kW]               | 49,700 [14.56]          | 49,700 [14.56]          |
| Net Latent Capacity Btu [kW]                 | 20,300 [5.95]           | 20,300 [5.95]           |
| IEER <sup>3</sup>                            | 11.7                    | 11.7                    |
| Net System Power kW                          | 6.21                    | 6.21                    |
| <b>Compressor</b>                            |                         |                         |
| No./Type                                     | 1/Scroll                | 1/Scroll                |
| <b>Outdoor Sound Rating (dB)<sup>5</sup></b> |                         |                         |
|  | 83                      | 83                      |
| <b>Outdoor Coil - Fin Type</b>               |                         |                         |
| Tube Type                                    | Louvered                | Louvered                |
| Tube Size in. [mm] OD                        | Rifled                  | Rifled                  |
| Face Area sq. ft. [sq. m]                    | 0.375 [9.5]             | 0.375 [9.5]             |
| Rows / FPI [FPcm]                            | 16.56 [1.54]            | 16.56 [1.54]            |
|  | 2 / 22 [9]              | 2 / 22 [9]              |
| <b>Indoor Coil - Fin Type</b>                |                         |                         |
| Tube Type                                    | Corrugated              | Corrugated              |
| Tube Size in. [mm]                           | Rifled                  | Rifled                  |
| Face Area sq. ft. [sq. m]                    | 0.375 [9.5]             | 0.375 [9.5]             |
| Rows / FPI [FPcm]                            | 6.5 [0.6]               | 6.5 [0.6]               |
| Refrigerant Control                          | 4 / 12 [5]              | 4 / 12 [5]              |
| Drain Connection No./Size in. [mm]           | TX Valves               | TX Valves               |
|  | 1/1 [25.4]              | 1/1 [25.4]              |
| <b>Outdoor Fan - Type</b>                    |                         |                         |
| No. Used/Diameter in. [mm]                   | Propeller               | Propeller               |
| Drive Type/No. Speeds                        | 1/24 [609.6]            | 1/24 [609.6]            |
| CFM [L/s]                                    | Direct/1                | Direct/1                |
| No. Motors/HP                                | 4000 [1888]             | 4000 [1888]             |
| Motor RPM                                    | 1 at 1/3 HP             | 1 at 1/3 HP             |
|  | 1075                    | 1075                    |
| <b>Indoor Fan - Type</b>                     |                         |                         |
| No. Used/Diameter in. [mm]                   | FC Centrifugal          | FC Centrifugal          |
| Drive Type/No. Speeds                        | 1/11x10 [279x254]       | 1/11x10 [279x254]       |
| No. Motors                                   | Belt/Variable           | Belt/Variable           |
| Motor HP                                     | 1                       | 1                       |
| Motor RPM                                    | 1 1/2                   | 1 1/2                   |
| Motor Frame Size                             | 1725                    | 1725                    |
|  | 0                       | 0                       |
| <b>Filter - Type</b>                         |                         |                         |
| Furnished                                    | Disposable              | Disposable              |
| (NO.) Size Recommended in. [mm x mm x mm]    | Yes                     | Yes                     |
|  | (4)2x16x16 [51x406x406] | (4)2x16x16 [51x406x406] |
| <b>Refrigerant Charge Oz. [g]</b>            |                         |                         |
|  | 191 [5415]              | 191 [5415]              |
| <b>Weights</b>                               |                         |                         |
| Net Weight lbs. [kg]                         | 569 [258]               | 569 [258]               |
| Ship Weight lbs. [kg]                        | 576 [261]               | 576 [261]               |

[ ] Designates Metric Conversions

### NOTES:

- Cooling Performance is rated at 95° F ambient, 80° F entering dry bulb, 67° F entering wet bulb. Gross capacity does not include the effect of fan motor heat. AHRI capacity is net and includes the effect of fan motor heat. Units are suitable for operation to ±20% of nominal cfm. Units are certified in accordance with the Unitary Air Conditioner Equipment certification program, which is based on AHRI Standard 210/240 or 360.
- EER and/or SEER are rated at AHRI conditions and in accordance with DOE test procedures.
- IEER is rated in accordance with AHRI Standard 210/240 or 340/360.
- Heating Performance limit settings and rating data were established and approved under laboratory test conditions using American National Standard Institute standards. Ratings shown are for elevations up to 2000 feet. For elevations above 2000 feet, ratings should be reduced at the rate of 4% for each 1000 feet above sea level.
- Outdoor Sound Rating shown is tested in accordance with AHRI Standard 270.

## VIII. INSTALLATION

### A. GENERAL

#### 1. PRE-INSTALLATION CHECK-POINTS

Before attempting any installation, the following points should be carefully considered:

- Structural strength of supporting members.  
(rooftop installation)
- Clearances and provision for servicing.
- Power supply and wiring.
- Air duct connections.
- Drain facilities and connections.
- Location for minimum noise.

#### 2. LOCATION

These units are designed for outdoor installations. They can be mounted on a slab or rooftop. They are not to be installed within any part of a structure such as an attic, crawl space, closet, or any other place where condenser air flow is restricted or other than outdoor ambient conditions prevail. Since the application of the units is of the outdoor type, it is important to consult your local code authorities at the time the first installation is made.

### B. OUTSIDE SLAB INSTALLATION (Typical outdoor slab installations are shown in Figures 6 and 7.)

- Select a location where external water drainage cannot collect around the unit.
- Provide a level concrete slab extending 3" beyond all four sides of the unit. The slab should be sufficient above grade to prevent ground water from entering the unit.

**IMPORTANT:** To prevent transmission of noise or vibration, slab should not be connected to building structure.

- The location of the unit should be such as to provide proper access for inspection and servicing.
- Locate unit where operating sounds will not disturb owner or neighbors.
- Locate unit so roof runoff water does not pour directly on the unit. Provide gutter or other shielding at roof level. Do not locate unit in an area where excessive snow drifting may occur or accumulate.

**FIGURE 6**  
PACKAGED AIR CONDITIONER  
OUTSIDE SLAB INSTALLATION, BASEMENT OR  
CRAWL SPACE DISTRIBUTION SYSTEM

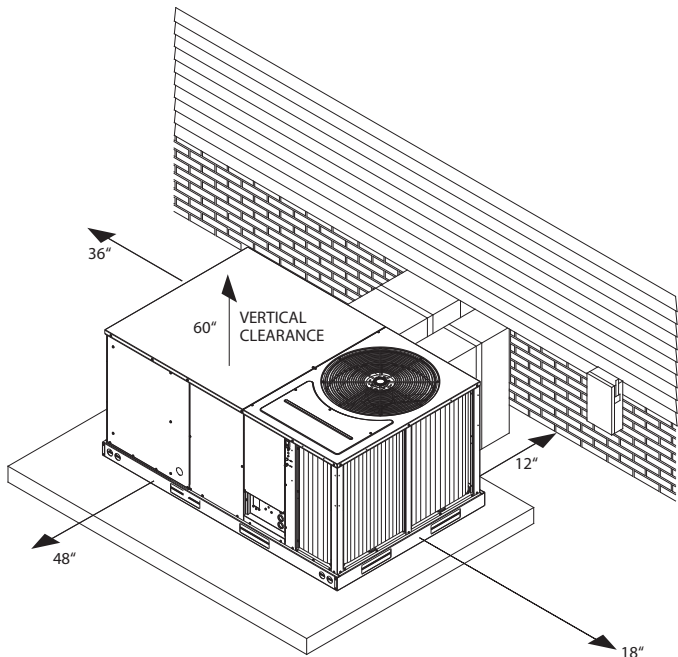

ST-A1142-13

**FIGURE 7**  
PACKAGED AIR CONDITIONER  
OUTSIDE SLAB INSTALLATION, CLOSET  
DISTRIBUTION SYSTEM. SLAB FLOOR  
CONSTRUCTION

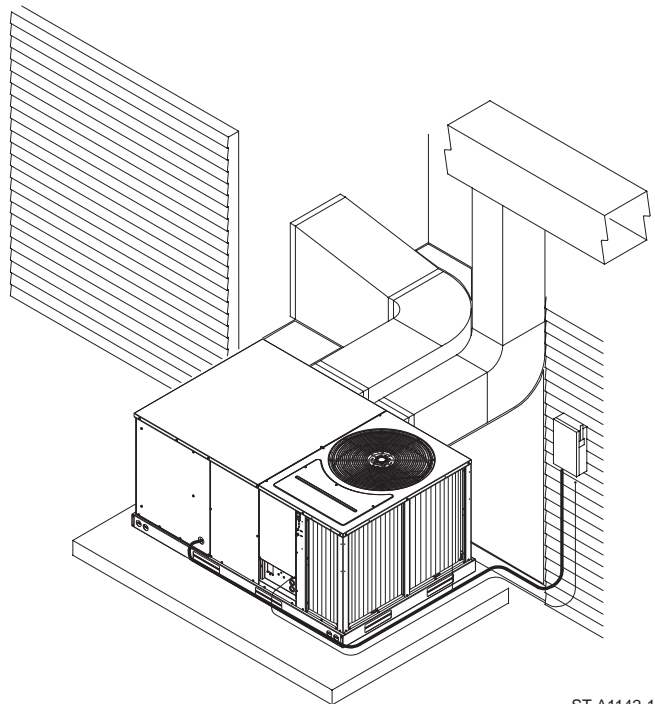

ST-A1142-12

**FIGURE 8**  
**PACKAGED AIR CONDITIONER**  
**RIGGING FOR LIFTING**

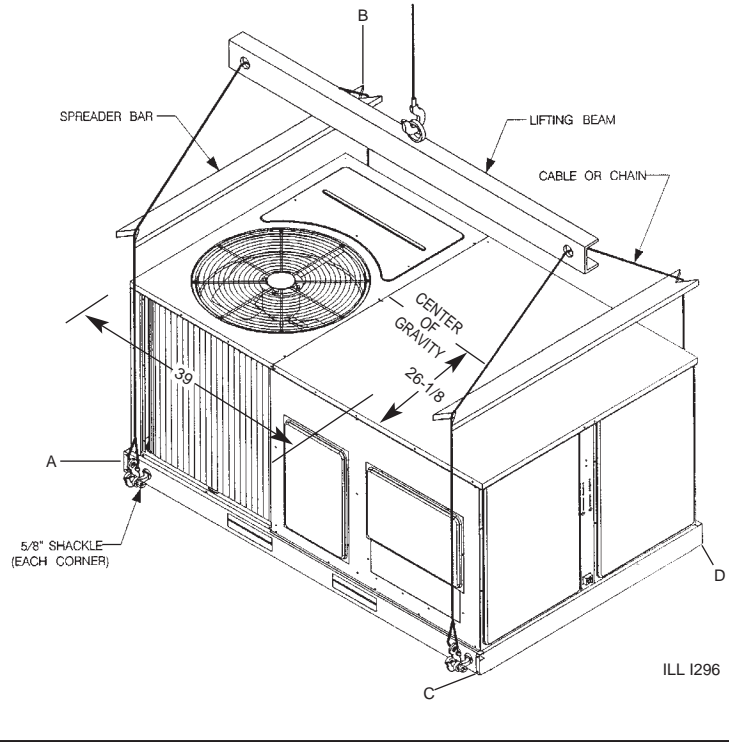

| CORNER WEIGHTS BY PERCENTAGE |     |     |     |
|------------------------------|-----|-----|-----|
| A                            | B   | C   | D   |
| 23%                          | 29% | 21% | 27% |

**FIGURE 9**  
**PACKAGED AIR CONDITIONER**  
**ROOFCURB INSTALLATION**

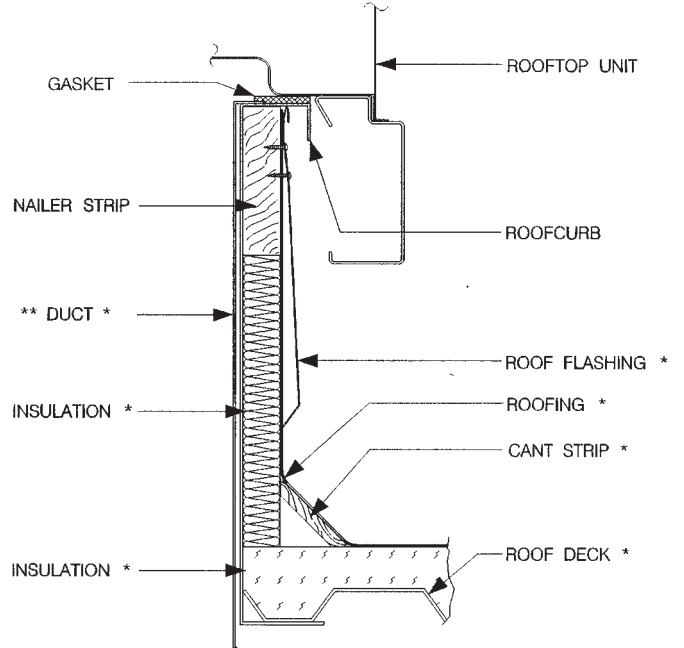
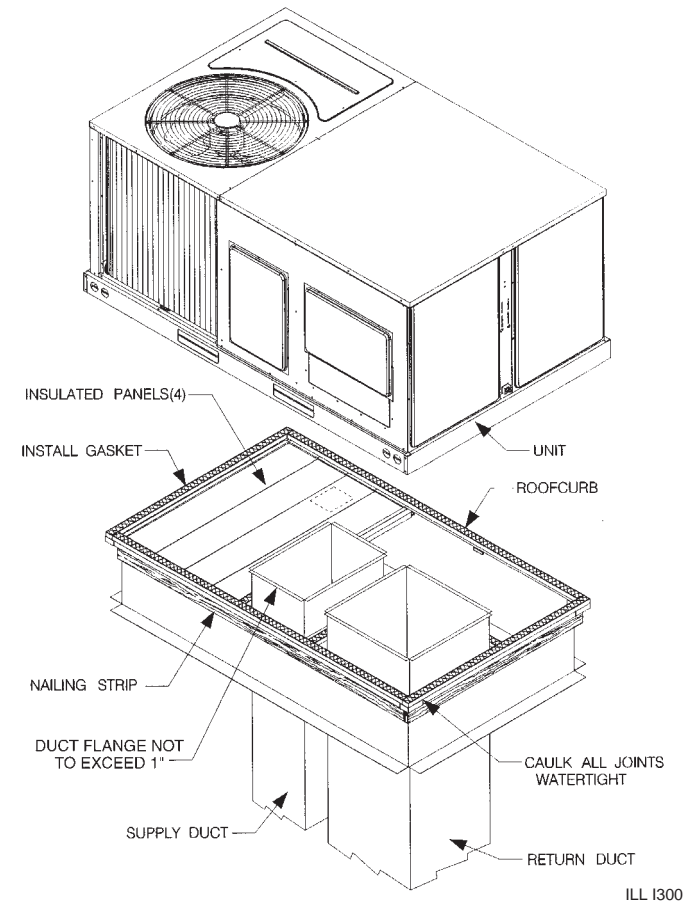

\* BY CONTRACTOR  
 \*\* FOR INSTALLATION OF DUCT AS SHOWN, USE RECOMMENDED DUCT SIZES FROM ROOFCURB INSTALLATION INSTRUCTIONS. FOR DUCT FLANGE ATTACHMENT TO UNIT, SEE UNIT INSTALLATION INSTRUCTIONS FOR RECOMMENDED DUCT SIZES.

## **▲ WARNING**

**DO NOT, UNDER ANY CIRCUMSTANCES, CONNECT RETURN DUCTWORK TO ANY OTHER HEAT PRODUCING DEVICE SUCH AS A FIREPLACE INSERT, STOVE, ETC. UNAUTHORIZED USE OF SUCH DEVICES MAY RESULT IN FIRE, CARBON MONOXIDE POISONING, EXPLOSION, PROPERTY DAMAGE, SEVERE PERSONAL INJURY OR DEATH.**

### **C. CLEARANCES**

The following minimum clearances must be observed for proper unit performance and serviceability.

1. Unit is design certified for application on combustible flooring with 0" minimum clearance.
2. See Figure 6 for illustration of minimum installation-service clearances.

### **D. ROOFTOP INSTALLATION**

1. Before locating the unit on the roof, make sure that the strength of the roof and beams is adequate at that point to support the weight involved. (See specification sheet for weight of unit.) This is very important and user's responsibility.
2. For rigging and roofcurb details, see Figures 8 and 9. Use field-furnished spreaders.
3. For roofcurb assembly, see Roofcurb Installation Instructions.
4. If the roofcurb is not used, provisions for disposing of condensate water runoff must be provided.
5. The unit should be placed on a solid and level roofcurb or platform of adequate strength. See Figure 10.
6. The location of the unit on the roof should be such as to provide proper access for inspection and servicing.

**IMPORTANT:** If unit will not be put into service immediately, cover supply and return openings to prevent excessive condensation.

**FIGURE 10**

#### **PACKAGED AIR CONDITIONER**

FLAT ROOFTOP INSTALLATION, ATTIC OR DROP CEILING DISTRIBUTION SYSTEM. MOUNTED ON ROOFCURB. CURB MUST BE LEVEL

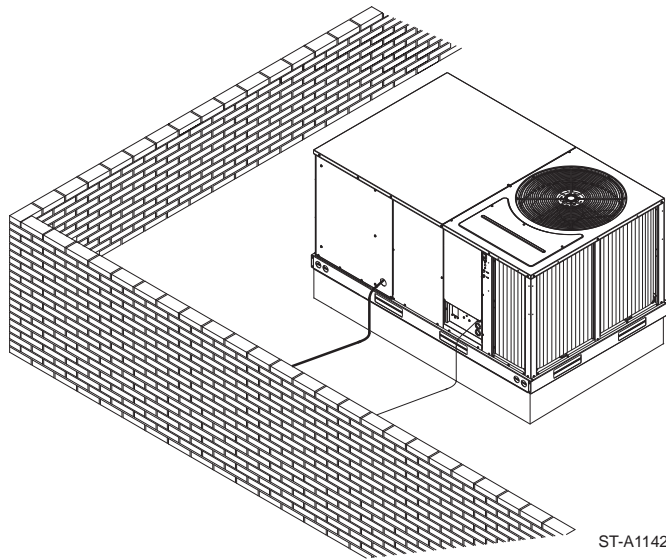

## **IX. DUCTWORK**

Ductwork should be fabricated by the installing contractor in accordance with local codes and NFPA90A. Industry manuals may be used as a guide when sizing and designing the duct system - contact Air Conditioning Contractors of America, 1513 16th St. N.W., Washington, D.C. 20036.

The unit should be placed as close to the space to be air conditioned as possible allowing clearance dimensions as indicated. Ducts should be run as directly as possible to supply and return outlets. Use of non-flammable waterproof flexible connectors on both supply and return connections at the unit to reduce noise transmission is recommended.

It is preferable to install the unit on the roof of the structure if the registers or diffusers are located on the wall or in the ceiling. A slab installation could be considered when the registers are low on a wall or in the floor.

On ductwork exposed to outside air conditions of temperature and humidity, use a minimum of 2" of insulation and a vapor barrier. Distribution system in attic, furred space or crawl space should be insulated with at least 2" of insulation with vapor barrier. One-

half to 1" thickness of insulation is usually sufficient for ductwork inside the air conditioned space.

Balancing dampers should be provided for each branch duct in the supply system. Ductwork should be properly supported from the structure.

When installing ductwork, consider the following items:

1. Noncombustible flexible connectors should be used between ductwork and unit to reduce noise and vibration transmission into the ductwork.
2. When auxiliary heaters are installed, use noncombustible flexible connectors and clearance to combustible material of 0" for the first 3 feet of discharge duct. Clearance to unit top and side is 0".

---

## X. FILTERS

This unit is provided with disposable filters. When replacing filters, ensure they are inserted fully to the back to prevent bypass.

---

## XI. CONVERSION PROCEDURE

### DOWNFLOW TO HORIZONTAL

1. Remove the screws and covers from the outside of the supply and return sections.
2. Install the covers in the bottom supply and return openings with the painted side up. See Figure 11. Use the existing gasket to seal the covers.

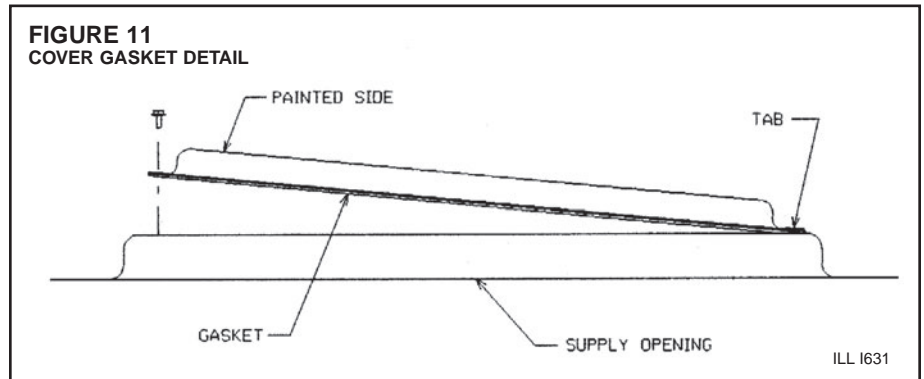

3. Secure the supply cover to the base of the unit with 1 screw, engaging prepunched tab in unit base.
4. Secure the return cover to the base of the unit with screws, engaging prepunched holes in the unit base.

---

## XII. CONDENSATE DRAIN

**IMPORTANT: Install a condensate trap to ensure proper condensate drainage. See Figure 12.**

The condensate drain pan has a threaded female 3/4 inch NPT connection. Consult local codes or ordinances for specific requirements of condensate drain piping and disposal.

- Use a thin layer of Teflon tape or paste on drain pan connections and install only hand tight.
- Do not over tighten drain pan connections as damage to the drain pan may occur.
- Drain line **MUST NOT** block service access panels.
- Drain line must be no smaller than drain pan outlet and adequately sized to accommodate the condensate discharge from the unit.
- Drain line should slope away from unit a minimum of 1/8" per foot to ensure proper drainage.
- Drain line must be routed to an acceptable drain or outdoors in accordance with local codes.
- Do not connect condensate drain line to a closed sewer pipe.
- Drain line may need insulation or freeze protection in certain applications.

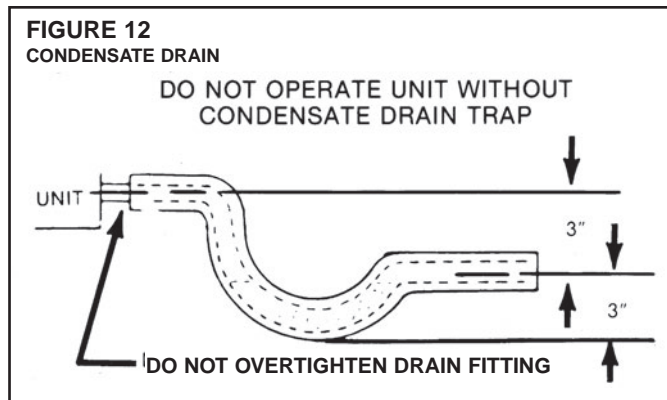

## XIII. ELECTRICAL WIRING

Field wiring must comply with the National Electrical Code\* and local ordinances that may apply.

\*C.E.C. in Canada

### A. POWER WIRING

1. It is important that proper electrical power is available at the unit. Voltage should not vary more than 10% from that stamped on the unit rating plate. On three phase units, phases must be balanced within 3%.
2. Install a branch circuit disconnect within sight of the unit and of adequate size.
3. For branch circuit wiring (main power supply to unit disconnect), the minimum wire size can be determined using the circuit ampacity found on the unit nameplate.
4. This unit incorporates single point electrical connection for unit and electric heat accessory.
5. Power wiring must be run in grounded rain-tight conduit. Connect the power field wiring as follows:
  - a. NO ELECTRIC HEAT - Connect the field wires directly to the contactor pigtail in the electric heat access area. Connect ground wire to ground lug.
  - b. WITH ELECTRIC HEAT - Connect the field wires to the terminal block on the electric heater kit in the electric heat access area. Connect the unit contactor pigtails to the appropriate fuse block on the heater kit. Connect the ground wire to the ground lug on the heater kit.

**NOTE:** For field installation of a heater kit, follow the instructions provided with the heater kit.

6. The pigtail wires in the electric heat access area are factory wired to the contactor in the control box.
7. DO NOT connect aluminum field wires to electric heat kit power input terminals.

| TABLE E. WIRE SIZES  |                        |   |        |
|----------------------|------------------------|---|--------|
| AWG Copper Wire Size | AWG Aluminum Wire Size | Connector Type and Size (or equivalent) |        |
| #12                  | #10                    | T&B Wire Nut                            | PT2    |
| #10                  | #8                     | T&B Wire Nut                            | PT3    |
| #8                   | #6                     | IlSCO Split Bolt                        | AK-6   |
| #6                   | #4                     | IlSCO Split Bolt                        | AK-4   |
| #4                   | #2                     | IlSCO Split Bolt                        | AK-2   |
| #3                   | #1                     | IlSCO Split Bolt                        | AK-1/0 |
| #2                   | #0                     | IlSCO Split Bolt                        | AK-1/0 |
| #1                   | #00                    | IlSCO Split Bolt                        | AK-2/0 |
| #0                   | #000                   | IlSCO Split Bolt                        | AK-4/0 |

### B. SPECIAL INSTRUCTIONS FOR POWER WIRING WITH ALUMINUM CONDUCTORS.

1. Select the equivalent aluminum wire size from the tabulation below:
2. Attach a length (6" or more) of recommended size copper wire to the unit terminals L1 and L3 for single phase, L1, L2, L3 for three phase.

## **▲ WARNING**

**THE UNIT MUST BE PERMANENTLY GROUNDED. A GROUNDING LUG IS PROVIDED IN THE ELECTRIC HEAT KIT ACCESS AREA FOR A GROUND WIRE. FAILURE TO GROUND THIS UNIT CAN RESULT IN FIRE OR ELECTRICAL SHOCK CAUSING PROPERTY DAMAGE, SEVERE PERSONAL INJURY OR DEATH.**

3. Splice copper wire pigtails to aluminum wire with U.L. recognized connectors for copper-aluminum splices. Follow these instructions very carefully to make a positive and lasting connection;
  - a. Strip insulation from aluminum conductor.
  - b. Coat the stripped end of the aluminum wire with the recommended inhibitor and wire brush aluminum surface through inhibitor. Inhibitors: Brundy, Pentex "A"; Alcoa, No. 2EJC; T&B KPOR Shield.
  - c. Clean and recoat aluminum conductor with inhibitor.
  - d. Make the splice using the above listed wire nuts or split bolt connectors.
  - e. Coat the entire connection with inhibitor and wrap with electrical insulating tape.

WARRANTY MAY NOT APPLY IF CONNECTIONS ARE NOT MADE PER INSTRUCTIONS

### **C. CONTROL WIRING (Class II)**

1. Low voltage wiring should not be run in conduit with power wiring.
2. Control wiring is routed through the 7/8" hole adjacent to the compressor access panel. See Figure 13. Use a minimum #18 AWG thermostat wire. For wire lengths exceeding 50', use #16 AWG thermostat wire. The low voltage wires are connected to the unit pigtails which are supplied with the unit in the low voltage connection box located below the unit control box.
3. Figure 13 shows representative low voltage connection diagrams. Read your thermostat installation instructions for any special requirements for your specific thermostat.

NOTE — Units installed in Canada require that an outdoor thermostat (30,000 min. cycles of endurance) be installed and be wired with C.E.C. Class I wiring.

### **D. INTERNAL WIRING**

1. A diagram of the internal wiring of this unit is located on the inside of the compressor access panel. If any of the original wire as supplied with the appliance must be replaced, the wire gauge and insulation must be the same as original wiring.

### **E. GROUNDING**

GROUNDING MAY BE ACCOMPLISHED BY GROUNDING THE POWER LINE CONDUIT TO THE UNIT. MAKE SURE THE CONDUIT NUT LOCKING TEETH HAVE PIERCED THE INSULATING PAINT FILM OF THE SIDE PANEL.

**FIGURE 13**  
LOW VOLTAGE CONNECTIONS DIAGRAMS

### **STANDARD CONTROL WIRING**

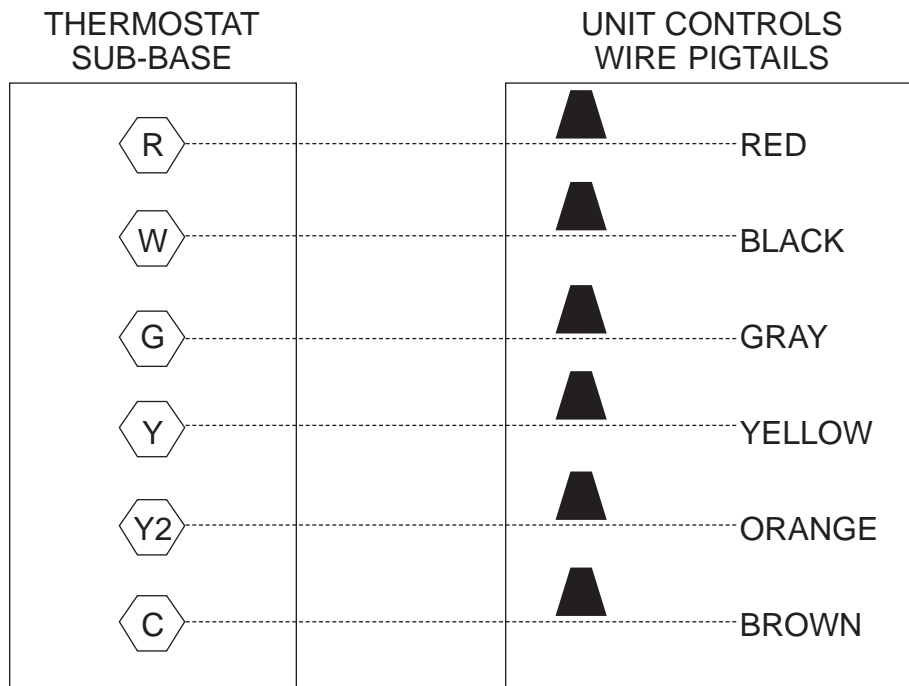

NOTE: Y2 IS ONLY USED WITH OPTIONAL ECONOMIZER.

**FIGURE 14**  
RECOMMENDED LOCATION OF BRANCH CIRCUIT DISCONNECT

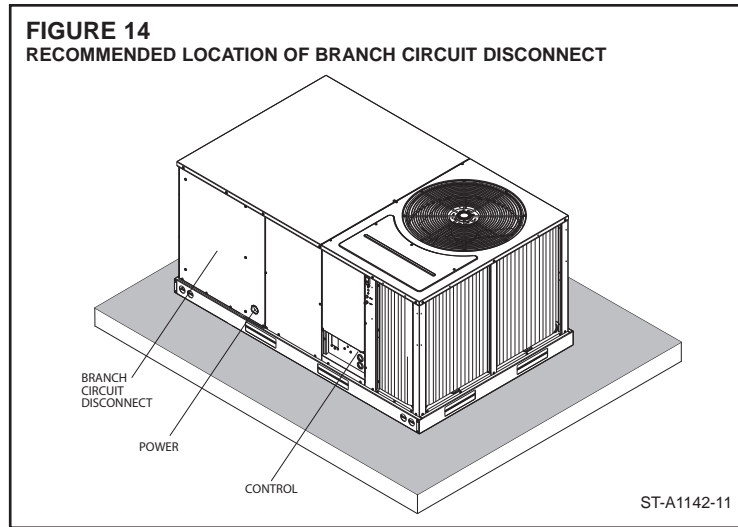

**F. THERMOSTAT**

The thermostat should be mounted on an inside wall about five feet above the floor in a location where it will not be affected by unconditioned air, sun, or drafts from open doors or other sources. READ installation instructions in thermostat package CAREFULLY because each has some different wiring requirements.

**XIV. ELECTRICAL DATA**

| ELECTRICAL DATA – RLKL SERIES |  |         |         |         |         |         |         |
|-------------------------------|--|---------|---------|---------|---------|---------|---------|
|                               |  | B072CL  | B072CM  | B072DL  | B072DM  | B072YL  | B072YM  |
| Unit Information              | Unit Operating Voltage Range               | 187-253 | 187-253 | 414-506 | 414-506 | 518-632 | 518-632 |
|                               | Volts                                      | 208/230 | 208/230 | 460     | 460     | 575     | 575     |
|                               | Minimum Circuit Ampacity                   | 33/33   | 33/33   | 17      | 17      | 13      | 13      |
|                               | Minimum Overcurrent Protection Device Size | 40/40   | 40/40   | 20      | 20      | 15      | 15      |
|                               | Maximum Overcurrent Protection Device Size | 50/50   | 50/50   | 20      | 20      | 15      | 15      |
| Compressor Motor              | No.  | 1       | 1       | 1       | 1       | 1       | 1       |
|                               | Volts                                      | 208/230 | 208/230 | 460     | 460     | 575     | 575     |
|                               | Phase                                      | 3       | 3       | 3       | 3       | 3       | 3       |
|                               | RPM  | 3450    | 3450    | 3450    | 3450    | 3450    | 3450    |
|                               | HP, Compressor 1                           | 5       | 5       | 5       | 5       | 5       | 5       |
|                               | Amps (RLA), Comp 1                         | 19.1/0  | 19.1/0  | 9.8     | 9.8     | 7.5     | 7.5     |
|                               | Amps (LRA), Comp 1                         | 123/0   | 123/0   | 62      | 62      | 50      | 50      |
| Condenser Motor               | No.  | 1       | 1       | 1       | 1       | 1       | 1       |
|                               | Volts                                      | 208/230 | 208/230 | 460     | 460     | 575     | 575     |
|                               | Phase                                      | 1       | 1       | 1       | 1       | 1       | 1       |
|                               | HP   | 1/3     | 1/3     | 1/3     | 1/3     | 1/3     | 1/3     |
|                               | Amps (FLA, each)                           | 2.6/2.6 | 2.6/2.6 | 1.25    | 1.25    | 0.9     | 0.9     |
|                               | Amps (LRA, each)                           | 4.7/4.7 | 4.7/4.7 | 2.4     | 2.4     | 1.5     | 1.5     |
| Evaporator Fan                | No.  | 1       | 1       | 1       | 1       | 1       | 1       |
|                               | Volts                                      | 208/230 | 208/230 | 460     | 460     | 575     | 575     |
|                               | Phase                                      | 3       | 3       | 3       | 3       | 3       | 3       |
|                               | HP   | 1 1/2   | 1 1/2   | 1 1/2   | 1 1/2   | 1 1/2   | 1 1/2   |
|                               | Amps (FLA, each)                           | 5.8/5.8 | 5.8/5.8 | 2.8     | 2.8     | 2.1     | 2.1     |
|                               | Amps (LRA, each)                           | 34/34   | 34/34   | 17      | 17      | 13.1    | 13.1    |



**FIGURE 15**  
**HEATER KIT INSTALLATION**

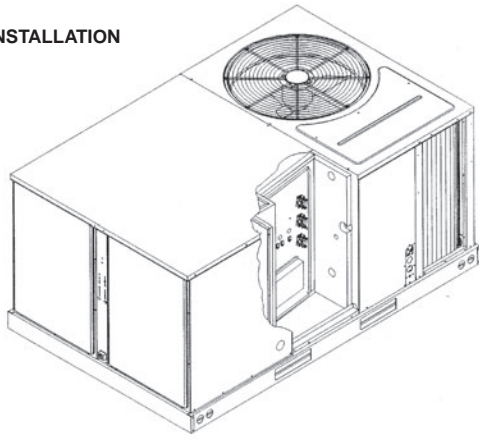

## XV. ELECTRIC HEATER KITS

| 208/240 VOLT, THREE PHASE, 60 HZ, AUXILIARY ELECTRIC HEATER KITS CHARACTERISTICS AND APPLICATION |                            |                       |                             |                            |                         |                                     |  |                   |                             |                         |                                |                                     |                   |
|--|----------------------------|-----------------------|-----------------------------|----------------------------|-------------------------|-------------------------------------|--|-------------------|-----------------------------|-------------------------|--------------------------------|-------------------------------------|-------------------|
| Single Power Supply for Both Unit and Heater Kit   |                            |                       |                             |                            |                         |                                     | Separate Power Supply for Both Unit and Heater Kit |                   |                             |                         |                                |                                     |                   |
| Unit Model Number RLKL-  | Heater Kit                 |                       |                             |                            |                         | Air Conditioner                     |  |                   | Heater Kit                  |                         | Air Conditioner                |                                     |                   |
|  | RXJJ-Heater Kit Nominal kW | No. of Sequence Steps | Rated Heater kW @ 208/240 V | Heater kBTU/Hr @ 208/240 V | Heater Amps @ 208/240 V | Unit Min. Ckt. Ampacity @ 208/240 V | Over Current Protective Device Size                |                   | Min. Ckt. Ampacity 208/240V | Max. Fuse Size 208/240V | Min. Circuit Ampacity 208/240V | Over Current Protective Device Size |                   |
|  |                            |                       |                             |                            |                         |                                     | Min./Max. @ 208 V                                  | Min./Max. @ 240 V |                             |                         |                                | Min./Max. @ 208 V                   | Min./Max. @ 240 V |
| B072CL   | No Heat                    | —                     | —                           | —                          | —                       | 33/33                               | 40/50  | 40/50             | —                           | —                       | 33/33                          | 40/50                               | 40/50             |
|  | A06C                       | 1                     | 4.2/5.6                     | 14.33/19.1                 | 11.7/13.5               | 33/33                               | 40/50  | 40/50             | 15/17                       | 15/20                   | —                              | —                                   | —                 |
|  | A10C                       | 1                     | 7.2/9.6                     | 24.56/32.75                | 20/23.1                 | 33/37                               | 40/50  | 40/50             | 25/29                       | 25/30                   | —                              | —                                   | —                 |
|  | A15C                       | 1                     | 10.8/14.4                   | 36.84/49.13                | 30.1/34.7               | 45/51                               | 45/50  | 60/60             | 38/44                       | 40/45                   | —                              | —                                   | —                 |
|  | A20C                       | 1                     | 14.4/19.2                   | 49.13/65.5                 | 40/46.3                 | 58/66                               | 60/60  | 70/70             | 50/58                       | 50/60                   | —                              | —                                   | —                 |
| B072CM   | A24C                       | 1                     | 18/24                       | 61.41/81.88                | 50/57.7                 | 70/80                               | 70/70  | 80/80             | 63/73                       | 70/80                   | —                              | —                                   | —                 |
|  | No Heat                    | —                     | —                           | —                          | —                       | 33/33                               | 40/50  | 40/50             | —                           | —                       | 33/33                          | 40/50                               | 40/50             |
|  | A06C                       | 1                     | 4.2/5.6                     | 14.33/19.1                 | 11.7/13.5               | 33/33                               | 40/50  | 40/50             | 15/17                       | 15/20                   | —                              | —                                   | —                 |
|  | A10C                       | 1                     | 7.2/9.6                     | 24.56/32.75                | 20/23.1                 | 33/37                               | 40/50  | 40/50             | 25/29                       | 25/30                   | —                              | —                                   | —                 |
|  | A15C                       | 1                     | 10.8/14.4                   | 36.84/49.13                | 30.1/34.7               | 45/51                               | 45/50  | 60/60             | 38/44                       | 40/45                   | —                              | —                                   | —                 |
| B072DM   | A20C                       | 1                     | 14.4/19.2                   | 49.13/65.5                 | 40/46.3                 | 58/66                               | 60/60  | 70/70             | 50/58                       | 50/60                   | —                              | —                                   | —                 |
|  | A24C                       | 1                     | 18/24                       | 61.41/81.88                | 50.57.7                 | 70/80                               | 70/70  | 80/80             | 63/73                       | 70/80                   | —                              | —                                   | —                 |

| 480 VOLT, THREE PHASE, 60 HZ, AUXILIARY ELECTRIC HEATER KITS CHARACTERISTICS AND APPLICATION |                            |                       |                         |                        |                     |                                 |  |                   |                         |                     |                            |                                     |                   |
|--|----------------------------|-----------------------|-------------------------|------------------------|---------------------|---------------------------------|--|-------------------|-------------------------|---------------------|----------------------------|-------------------------------------|-------------------|
| Single Power Supply for Both Unit and Heater Kit   |                            |                       |                         |                        |                     |                                 | Separate Power Supply for Both Unit and Heater Kit |                   |                         |                     |                            |                                     |                   |
| Unit Model Number RLKL-  | Heater Kit                 |                       |                         |                        |                     | Air Conditioner                 |  |                   | Heater Kit              |                     | Air Conditioner            |                                     |                   |
|  | RXJJ-Heater Kit Nominal kW | No. of Sequence Steps | Rated Heater kW @ 480 V | Heater kBTU/Hr @ 480 V | Heater Amps @ 480 V | Unit Min. Ckt. Ampacity @ 480 V | Over Current Protective Device Size                |                   | Min. Ckt. Ampacity 480V | Max. Fuse Size 480V | Min. Circuit Ampacity 480V | Over Current Protective Device Size |                   |
|  |                            |                       |                         |                        |                     |                                 | Min./Max. @ 480 V                                  | Min./Max. @ 480 V |                         |                     |                            | Min./Max. @ 480 V                   | Min./Max. @ 480 V |
| B072DL   | No Heat                    | —                     | —                       | —                      | —                   | 17                              | 20/20  | —                 | —                       | —                   | 17                         | 20/20                               | —                 |
|  | A06D                       | 1                     | 5.6                     | 19.1                   | 6.8                 | 17                              | 20/25  | —                 | 9                       | 15                  | —                          | —                                   | —                 |
|  | A10D                       | 1                     | 9.6                     | 32.75                  | 11.6                | 19                              | 20/25  | —                 | 15                      | 15                  | —                          | —                                   | —                 |
|  | A15D                       | 1                     | 14.4                    | 49.13                  | 17.4                | 26                              | 30/30  | —                 | 22                      | 25                  | —                          | —                                   | —                 |
|  | A20D                       | 1                     | 19.2                    | 65.5                   | 23.3                | 33                              | 35/35  | —                 | 30                      | 30                  | —                          | —                                   | —                 |
| B072DM   | A24D                       | 1                     | 24                      | 81.88                  | 28.9                | 40                              | 40/40  | —                 | 37                      | 40                  | —                          | —                                   | —                 |
|  | No Heat                    | —                     | —                       | —                      | —                   | 17                              | 20/20  | —                 | —                       | —                   | 17                         | 20/20                               | —                 |
|  | A06D                       | 1                     | 5.6                     | 19.1                   | 6.8                 | 17                              | 20/25  | —                 | 9                       | 15                  | —                          | —                                   | —                 |
|  | A10D                       | 1                     | 9.6                     | 32.75                  | 11.6                | 19                              | 20/25  | —                 | 15                      | 15                  | —                          | —                                   | —                 |
|  | A15D                       | 1                     | 14.4                    | 49.13                  | 17.4                | 26                              | 30/30  | —                 | 22                      | 25                  | —                          | —                                   | —                 |
| B072DM   | A20D                       | 1                     | 19.2                    | 65.5                   | 23.3                | 33                              | 35/35  | —                 | 30                      | 30                  | —                          | —                                   | —                 |
|  | A24D                       | 1                     | 24                      | 81.88                  | 28.9                | 40                              | 40/40  | —                 | 37                      | 40                  | —                          | —                                   | —                 |

| 600 VOLT, THREE PHASE, 60 HZ, AUXILIARY ELECTRIC HEATER KITS CHARACTERISTICS AND APPLICATION |                            |                       |                         |                        |                     |                                 |  |                   |                         |                     |                            |                                     |                   |
|--|----------------------------|-----------------------|-------------------------|------------------------|---------------------|---------------------------------|--|-------------------|-------------------------|---------------------|----------------------------|-------------------------------------|-------------------|
| Single Power Supply for Both Unit and Heater Kit   |                            |                       |                         |                        |                     |                                 | Separate Power Supply for Both Unit and Heater Kit |                   |                         |                     |                            |                                     |                   |
| Unit Model Number RLKL-  | Heater Kit                 |                       |                         |                        |                     | Air Conditioner                 |  |                   | Heater Kit              |                     | Air Conditioner            |                                     |                   |
|  | RXJJ-Heater Kit Nominal kW | No. of Sequence Steps | Rated Heater kW @ 600 V | Heater kBTU/Hr @ 600 V | Heater Amps @ 600 V | Unit Min. Ckt. Ampacity @ 600 V | Over Current Protective Device Size                |                   | Min. Ckt. Ampacity 600V | Max. Fuse Size 600V | Min. Circuit Ampacity 600V | Over Current Protective Device Size |                   |
|  |                            |                       |                         |                        |                     |                                 | Min./Max. @ 600 V                                  | Min./Max. @ 600 V |                         |                     |                            | Min./Max. @ 600 V                   | Min./Max. @ 600 V |
| B072YL   | No Heat                    | —                     | —                       | —                      | —                   | 13                              | 15/15  | —                 | —                       | —                   | 13                         | 15/15                               | —                 |
|  | A15Y                       | 1                     | 14.4                    | 49.13                  | 13.9                | 20                              | 20/20  | —                 | 18                      | 20                  | —                          | —                                   | —                 |
|  | A20Y                       | 1                     | 19.2                    | 65.5                   | 18.8                | 27                              | 30/30  | —                 | 24                      | 25                  | —                          | —                                   | —                 |
|  | A24Y                       | 1                     | 24                      | 81.88                  | 23.1                | 32                              | 35/35  | —                 | 29                      | 30                  | —                          | —                                   | —                 |
| B072YM   | No Heat                    | —                     | —                       | —                      | —                   | 13                              | 15/15  | —                 | —                       | —                   | 13                         | 15/15                               | —                 |
|  | A15Y                       | 1                     | 14.4                    | 49.13                  | 13.9                | 20                              | 20/20  | —                 | 18                      | 20                  | —                          | —                                   | —                 |
|  | A20Y                       | 1                     | 19.2                    | 65.5                   | 18.8                | 27                              | 30/30  | —                 | 24                      | 25                  | —                          | —                                   | —                 |
|  | A24Y                       | 1                     | 24                      | 81.88                  | 23.1                | 32                              | 35/35  | —                 | 29                      | 30                  | —                          | —                                   | —                 |

## XVI. BELT-DRIVE AIRFLOW PERFORMANCE 6 TON MODEL

| AIR FLOW CFM | CAPACITY 6 TON<br>VOLTAGE 208-230, 460 & 575 V - 3 PHASE |      |       |      |       |      |       |      |       |      |       |      |       |      |       |      |       |      |       |      |       |      |       |      |       |      |       |      |       |
|--------------|--|------|-------|------|-------|------|-------|------|-------|------|-------|------|-------|------|-------|------|-------|------|-------|------|-------|------|-------|------|-------|------|-------|------|-------|
|              | EXTERNAL STATIC PRESSURE-INCHES OF WATER                 |      |       |      |       |      |       |      |       |      |       |      |       |      |       |      |       |      |       |      |       |      |       |      |       |      |       |      |       |
|              | 0.1  |      | 0.2   |      | 0.3   |      | 0.4   |      | 0.5   |      | 0.6   |      | 0.7   |      | 0.8   |      | 0.9   |      | 1.0   |      | 1.10  |      | 1.20  |      | 1.30  |      | 1.40  |      | 1.50  |
| RPM          | WATTS  | RPM  | WATTS | RPM  | WATTS | RPM  | WATTS | RPM  | WATTS | RPM  | WATTS | RPM  | WATTS | RPM  | WATTS | RPM  | WATTS | RPM  | WATTS | RPM  | WATTS | RPM  | WATTS | RPM  | WATTS | RPM  | WATTS | RPM  | WATTS |
| 1800         | —  | —    | —     | 785  | 560   | 850  | 605   | 895  | 650   | 930  | 670   | 975  | 720   | 1010 | 760   | 1050 | 800   | 1090 | 850   | 1120 | 890   | 1150 | 940   | 1180 | 980   | 1210 | 1015  | 1015 | 1015  |
| 2000         | —  | 775  | 600   | 815  | 625   | 860  | 675   | 880  | 720   | 895  | 750   | 820  | 840   | 880  | 900   | 940  | 960   | 995  | 1030  | 1060 | 1085  | 1115 | 1145  | 1175 | 1205  | 1230 | 1205  | 1205 | 1205  |
| 2100         | —  | —    | 810   | 650  | 840   | 680  | 740   | 820  | 780   | 855  | 820   | 860  | 900   | 920  | 955   | 980  | 1005  | 1025 | 1050  | 1075 | 1100  | 1125 | 1150  | 1175 | 1200  | 1225 | 1250  | 1275 | 1295  |
| 2200         | 780  | 660  | 825   | 700  | 865   | 750  | 910   | 810  | 870   | 945  | 880   | 930  | 1005  | 930  | 1065  | 1015 | 1100  | 1045 | 1120  | 1100 | 1145  | 1180 | 1220  | 1205 | 1240  | 1255 | 1380  | 1380 | 1380  |
| 2300         | 815  | 720  | 855   | 760  | 890   | 830  | 930   | 870  | 960   | 1000 | 960   | 1035 | 1005  | 1065 | 1100  | 1130 | 1180  | 1180 | 1250  | 1200 | 1250  | 1325 | 1220  | 1370 | 1240  | 1425 | —     | —    | —     |
| 2400         | 845  | 780  | 880   | 835  | 920   | 900  | 950   | 1025 | 1050  | 1090 | 1025  | 1065 | 1110  | 1085 | 1150  | 1135 | 1180  | 1235 | 1185  | 1220 | 1260  | 1325 | 1235  | 1470 | 1255  | 1525 | —     | —    | —     |
| 2500         | 870  | 855  | 910   | 915  | 945   | 975  | 980   | 1020 | 1085  | 1045 | 1140  | 1080 | 1240  | 1110 | 1260  | 1135 | 1300  | 1390 | 1205  | 1450 | 1230  | 1530 | 1250  | 1580 | 1295  | 1630 | —     | —    | —     |
| 2600         | 900  | 945  | 940   | 1005 | 975   | 1060 | 1105  | 1040 | 1175  | 1065 | 1225  | 1100 | 1235  | 1135 | 1350  | 1165 | 1425  | 1505 | 1225  | 1580 | 1240  | 1635 | 1270  | 1665 | —     | —    | —     | —    | —     |
| 2700         | 930  | 1075 | 970   | 1100 | 1000  | 1145 | 1030  | 1200 | 1060  | 1260 | 1090  | 1335 | 1125  | 1305 | 1470  | 1185 | 1540  | 1615 | 1235  | 1675 | 1255  | 1730 | —     | —    | —     | —    | —     | —    | —     |

| DRIVE PACKAGE | "L"                           |      |      |     |     |     | "M"                           |      |      |      |      |      |      |
|---------------|-------------------------------|------|------|-----|-----|-----|-------------------------------|------|------|------|------|------|------|
| MOTOR H.P.    | 1-1/2                         |      |      |     |     |     | 1-1/2                         |      |      |      |      |      |      |
| BLOWER SHEAVE | 6.4 PITCH DIAMETER            |      |      |     |     |     | 6.4 PITCH DIAMETER            |      |      |      |      |      |      |
| MOTOR SHEAVE  | 2.8-3.8 PITCH DIAMETER - ADJ. |      |      |     |     |     | 3.4-4.4 PITCH DIAMETER - ADJ. |      |      |      |      |      |      |
| URNS OPEN     | 0                             | 1    | 2    | 3   | 4   | 5   | 0                             | 1    | 2    | 3    | 4    | 5    | 6    |
| RPM           | 1100                          | 1050 | 1000 | 945 | 895 | 845 | 1295                          | 1230 | 1195 | 1145 | 1100 | 1050 | 1000 |

## XVII. INDOOR AIR FLOW DATA

Belt-drive blower models have motor sheaves set for proper CFM at a typical external static. See tables for blower performance.

---

## XVIII. CRANKCASE HEAT (OPTIONAL)

Crankcase heat is not required on scroll type compressors, but may be necessary for certain situations.

---

## XIX. PRE-START CHECK

1. Is unit properly located and slightly slanted toward indoor condensate drain?
  2. Is ductwork insulated, weatherproofed, with proper spacing to combustible materials?
  3. Is air free to travel to and from outdoor coil?
  4. Is the wiring correct, tight, and according to unit wiring diagram?
  5. Is unit grounded?
  6. Are field supplied air filters in place and clean?
  7. Do the outdoor fan and indoor blower turn freely without rubbing, and are they tight on the motor shafts?
- 

## XX. STARTUP

1. Turn thermostat to "OFF," turn "on" power supply at disconnect switch.
2. Turn temperature setting as high as it will go.
3. Turn fan switch to "ON."
4. Indoor blower should run. Be sure it is running in the right direction.
5. Turn fan switch to "AUTO." Turn system switch to "COOL" and turn temperature setting below room temperature. Unit should run in cooling mode.
6. Is outdoor fan operating correctly in the right direction?
7. Is compressor running correctly.
8. Check the refrigerant charge using the instructions located on compressor access panel. Replace service port caps. Service port cores are for system access only and will leak if not tightly capped.
9. Turn thermostat system switch to proper mode "HEAT" or "COOL" and set thermostat to proper temperature setting. Record the following after the unit has run some time.
  - A. Operating Mode \_\_\_\_\_
  - B. Discharge Pressure (High) \_\_\_\_\_ PSIG
  - C. Vapor Pressure at Compressor (Low) \_\_\_\_\_ PSIG
  - D. Vapor Line Temperature at Compressor \_\_\_\_\_ °F.
  - E. Indoor Dry Bulb \_\_\_\_\_ °F.
  - F. Indoor Wet Bulb \_\_\_\_\_ °F.
  - G. Outdoor Dry Bulb \_\_\_\_\_ °F.
  - H. Outdoor Wet Bulb \_\_\_\_\_ °F.
  - I. Voltage at Contactor \_\_\_\_\_ Volts
  - J. Current at Contactor \_\_\_\_\_ Amps
  - K. Model Number \_\_\_\_\_
  - L. Serial Number \_\_\_\_\_
  - M. Location \_\_\_\_\_
  - N. Owner \_\_\_\_\_
  - O. Date \_\_\_\_\_
10. Adjust discharge air grilles and balance system.
11. Check ducts for condensation and air leaks.
12. Check unit for tubing and sheet metal rattles.
13. Instruct the owner on operation and maintenance.
14. Leave "INSTALLATION" and "USE AND CARE" instructions with owner.

## **▲ WARNING**

ONLY ELECTRIC HEATER KITS SUPPLIED BY THIS MANUFACTURER AS DESCRIBED IN THIS PUBLICATION HAVE BEEN DESIGNED, TESTED, AND EVALUATED BY A NATIONALLY RECOGNIZED SAFETY TESTING AGENCY FOR USE WITH THIS UNIT. USE OF ANY OTHER MANUFACTURED ELECTRIC HEATERS INSTALLED WITHIN THIS UNIT MAY CAUSE HAZARDOUS CONDITIONS RESULTING IN PROPERTY DAMAGE, FIRE, BODILY INJURY OR DEATH.

## **XXI. OPERATION**

**IMPORTANT:** The compressor has an internal overload protector. Under some conditions, it can take up to 2 hours for this overload to reset. Make sure overload has had time to reset before condemning the compressor.

### **CONTROL SYSTEM OPERATION**

1. In the cooling mode, the thermostat will, on a call for cooling, energize the compressor contactor and the indoor blower relay. The indoor blower can be operated continuously by setting the thermostat fan switch at the "ON" position.
- 

## **XXII. AUXILIARY HEAT**

In the heating mode, the thermostat will energize one or more supplementary resistance heaters.

---

## **XXIII. REPLACEMENT PARTS**

Contact your local distributor for a complete parts list.

---

## **XXIV. CHARGE INFORMATION**

Refer to the appropriate charge chart included in this manual.

---

## **XXV. TROUBLESHOOTING**

Refer to the troubleshooting chart included in this manual.

---

## **XXVI. WIRING DIAGRAMS**

Refer to the appropriate wiring diagram included in this manual.

FIGURE 16  
CHARGING CHARTS

# 6 TON AIR CONDITIONER

## SYSTEM CHARGE CHART - REFRIGERANT 410A 6 TON, CIRCUIT 1

**CAUTION:** 1. RETURN AIR TEMPERATURE MUST BE WITHIN COMFORT CONDITIONS BEFORE FINAL REFRIGERANT CHECK!

- INSTRUCTIONS:**
1. MEASURE PRESSURE AT COMPRESSOR SUCTION AND LIQUID.
  2. MEASURE OUTDOOR AMBIENT TO UNIT.
  3. PLACE (X) ON CHART WHERE SUCTION AND LIQUID INTERSECT.
  4. IF (X) IS BELOW OUTDOOR AMBIENT LINE, ADD CHARGE AND REPEAT STEPS 1-3.
  5. IF (X) IS ABOVE OUTDOOR AMBIENT LINE, RECOVER EXCESS CHARGE AND REPEAT STEPS 1-3.

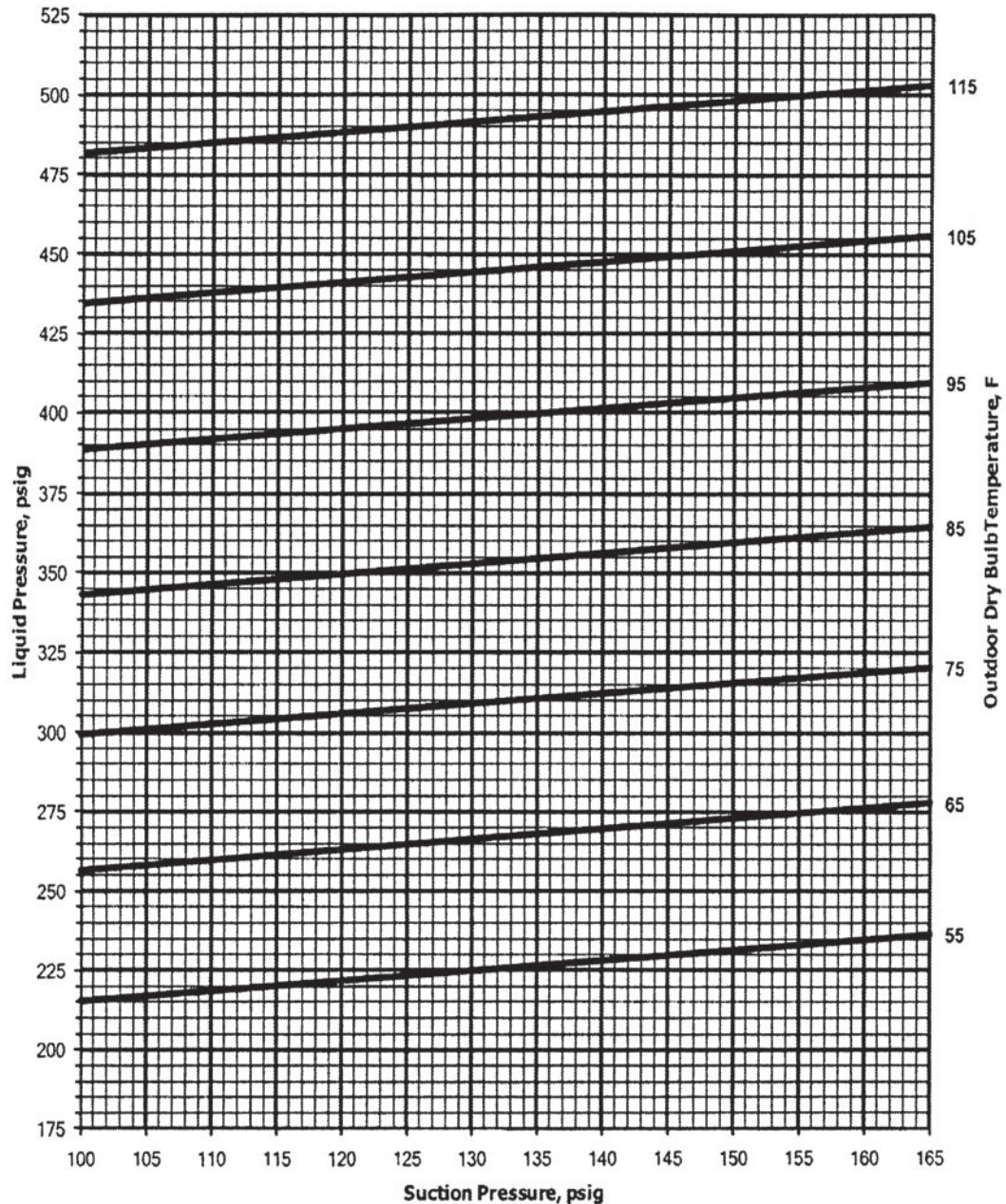

92-102259-18-00

# TROUBLE SHOOTING CHART

**▲ WARNING**

**DISCONNECT ALL POWER TO UNIT BEFORE SERVICING. CONTACTOR MAY BREAK ONLY ONE SIDE. FAILURE TO SHUT OFF POWER CAN CAUSE ELECTRICAL SHOCK RESULTING IN PERSONAL INJURY OR DEATH.**

| SYMPTOM  | POSSIBLE CAUSE  | REMEDY   |
|--|---|--|
| Unit will not run  | <ul style="list-style-type: none"> <li>• Power off or loose electrical connection</li> <li>• Thermostat out of calibration-set too high</li> <li>• Defective contactor</li> <li>• Blown fuses</li> <li>• Transformer defective</li> <li>• High pressure control open (if provided)</li> <li>• Interconnecting low voltage wiring damaged</li> </ul> | <ul style="list-style-type: none"> <li>• Check for correct voltage at compressor contactor in control box</li> <li>• Reset</li> <li>• Check for 24 volts at contactor coil - replace if contacts are open</li> <li>• Replace fuses</li> <li>• Check wiring-replace transformer</li> <li>• Reset-also see high head pressure remedy-The high pressure control opens at 450 PSIG</li> <li>• Replace thermostat wiring</li> </ul> |
| Condenser fan runs, compressor doesn't                     | <ul style="list-style-type: none"> <li>• Run capacitor defective (single phase only)</li> <li>• Start relay defective (single phase on;y)</li> <li>• Loose connection</li> <li>• Compressor stuck, grounded or open motor winding, open internal overload.</li> <li>• Low voltage condition</li> <li>• Low voltage condition</li> </ul>             | <ul style="list-style-type: none"> <li>• Replace</li> <li>• Replace</li> <li>• Check for correct voltage at compressor - check &amp; tighten all connections</li> <li>• Wait at least 2 hours for overload to reset. If still open, replace the compressor.</li> <li>• At compressor terminals, voltage must be within 10% of rating plate volts when unit is operating</li> <li>• Add start kit components</li> </ul>         |
| Insufficient cooling                                       | <ul style="list-style-type: none"> <li>• Improperly sized unit</li> <li>• Improper airflow</li> <li>• Incorrect refrigerant charge</li> <li>• Air, non-condensibles or moisture in system</li> <li>• Incorrect voltage</li> </ul>   | <ul style="list-style-type: none"> <li>• Recalculate load</li> <li>• Check - should be approximately 400 CFM per ton.</li> <li>• Charge per procedure attached to unit service panel</li> <li>• Recover refrigerant, evacuate &amp; recharge, add filter drier</li> <li>• At compressor terminals, voltage must be within 10% of rating plate volts when unit is operating.</li> </ul>   |
| Compressor short cycles                                    | <ul style="list-style-type: none"> <li>• Incorrect voltage</li> <li>• Defective overload protector</li> <li>• Refrigerant undercharge</li> </ul>  | <ul style="list-style-type: none"> <li>• At compressor terminals, voltage must be <math>\pm 10\%</math> of nameplate marking when unit is operating.</li> <li>• Replace - check for correct voltage</li> <li>• Add refrigerant</li> </ul>  |
| Registers sweat  | <ul style="list-style-type: none"> <li>• Low evaporator airflow</li> </ul>  | <ul style="list-style-type: none"> <li>• Increase speed of blower or reduce restriction - replace air filter</li> </ul>  |
| High head-low vapor pressures                              | <ul style="list-style-type: none"> <li>• Restriction in liquid line, expansion device or filter drier</li> <li>• Flow check piston size too small</li> <li>• Incorrect capillary tubes</li> <li>• TXV does not open</li> </ul>  | <ul style="list-style-type: none"> <li>• Remove or replace defective component</li> <li>• Change to correct size piston</li> <li>• Change coil assembly</li> <li>• Replace TXV</li> </ul>  |
| High head-high or normal vapor pressure - Cooling mode     | <ul style="list-style-type: none"> <li>• Dirty condenser coil</li> <li>• Refrigerant overcharge</li> <li>• Condenser fan not running</li> <li>• Air or non-condensibles in system</li> </ul>  | <ul style="list-style-type: none"> <li>• Clean coil</li> <li>• Correct system charge</li> <li>• Repair or replace</li> <li>• Recover refrigerant, evacuate &amp; recharge</li> </ul>   |
| Low head-high vapor pressures                              | <ul style="list-style-type: none"> <li>• Flow check piston size too large</li> <li>• Defective Compressor valves</li> <li>• Incorrect capillary tubes</li> </ul>  | <ul style="list-style-type: none"> <li>• Change to correct size piston</li> <li>• Replace compressor</li> <li>• Replace coil assembly</li> </ul>   |
| Low vapor - cool compressor - iced evaporator coil         | <ul style="list-style-type: none"> <li>• Low evaporator airflow</li> <li>• Operating below 65°F outdoors</li> <li>• Moisture in system</li> <li>• TXV limiting refrigerant flow</li> </ul>  | <ul style="list-style-type: none"> <li>• Increase speed of blower or reduce restriction - replace air filter</li> <li>• Add Low Ambient Kit</li> <li>• Recover refrigerant - evacuate &amp; recharge - add filter drier</li> <li>• Replace TXV</li> </ul>  |
| High vapor pressure  | <ul style="list-style-type: none"> <li>• Excessive load</li> <li>• Defective compressor</li> </ul>  | <ul style="list-style-type: none"> <li>• Recheck load calculation</li> <li>• Replace</li> </ul>  |
| Fluctuating head & vapor pressures                         | <ul style="list-style-type: none"> <li>• TXV hunting</li> <li>• Air or non-condensate in system</li> </ul>  | <ul style="list-style-type: none"> <li>• Check TXV bulb clamp - check air distribution on coil - replace TXV</li> <li>• Recover refrigerant, evacuate &amp; recharge</li> </ul>  |
| Gurgle or pulsing noise at expansion device or liquid line | <ul style="list-style-type: none"> <li>• Air or non-condensibles in system</li> </ul>   | <ul style="list-style-type: none"> <li>• Recover refrigerant, evacuate &amp; recharge</li> </ul>   |

**FIGURE 17**  
**WIRING DIAGRAM**

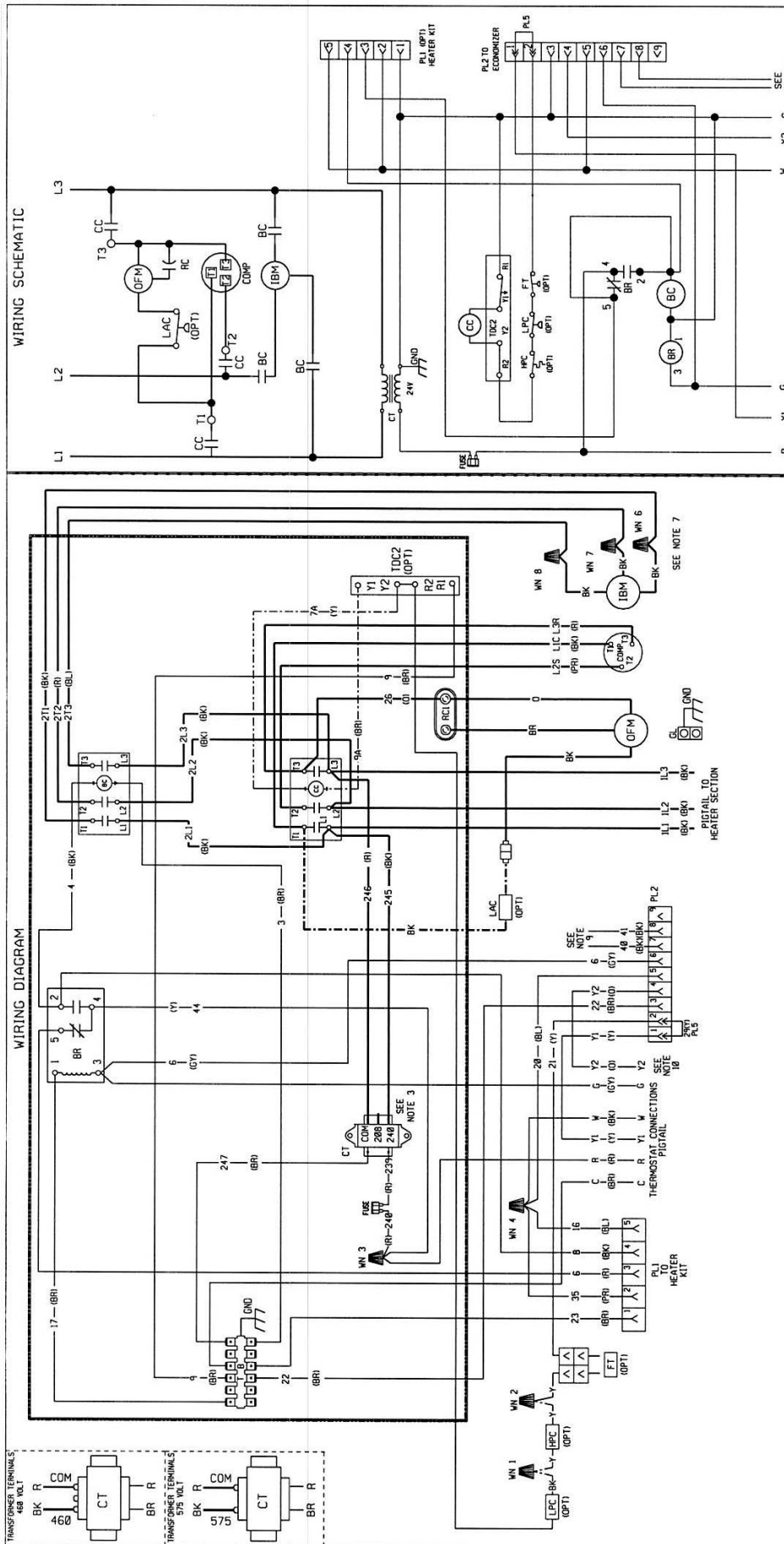

|  |   |  |   |  |
|--|---|--|---|--|
| <p><b>COMPONENT CODE</b></p> <p>BC BLOWER MOTOR<br/>BR BLOWER RELAY<br/>BR BLOWER CONTACTOR<br/>CM COMPRESSOR MOTOR<br/>CC CONTROL TRANSFORMER<br/>CT FREEZE STAT<br/>GL GROUND LUG<br/>HND GROUND PRESSURE CONTROL<br/>IBMBD INDOOR BLOWER MOTOR BELT DRIVE<br/>LPC LOW AMBIENT COOLING CONTROL<br/>OPM OUTDOOR FAN MOTOR<br/>PC PRESSURE CONTROL<br/>RC RUN CAPACITOR<br/>TB TERMINAL BLOCK (LOW VOLTAGE)<br/>TDC TIME DELAY CONTROL<br/>WN WIRE NUT</p> | <p><b>NOTES:</b></p> <p>1. CONNECTORS SUITABLE FOR USE WITH COPPER CONDUCTORS ONLY.<br/>2. COMPRESSOR MOTOR THERMALLY PROTECTED. ALL 3 PHASE MODELS.<br/>3. TRANSFORMER FACTORY WIRING IN GROUNDING MAIN TIGHT CONDUIT TO 60 HZ.<br/>4. MOVE BLACK WIRE TO 288 VOLT TAP FOR 208 VOLT APPLICATION.<br/>5. SEE INSET FOR OTHER VOLTAGES.<br/>6. SUPPLIED DIGITAL.<br/>7. FACTORY WIRING. CONNECT FIELD WIRE TO FACTORY.<br/>8. LOW VOLTAGE CIRCUIT IS N.E.C. CLASS 2 WITH A CLASS 2 TRANSFORMER. 24V/30/60 HZ SUPPLIED.<br/>9. FUSED DISCONNECT.<br/>10. MOTOR FACTORY WIRING FOR CORRECT SPEED.<br/>11. CLASSIFICATION ON UNIT FUSE BOX FOR FUSE SIZING AND CLASSIFICATION.<br/>12. WIRES FROM PL2 (6 &amp; 9) GO TO THE MIXED AIR SENSOR ON THE OPTIONAL ECONOMIZER.<br/>13. Y2 IS USED ONLY FOR THE OPTIONAL ECONOMIZER.</p> | <p><b>WIRING INFORMATION</b></p> <p>LINE VOLTAGE<br/>-FACTORY STANDARD<br/>-FACTORY OPTION<br/>-FIELD INSTALLED</p> <p>LOW VOLTAGE<br/>-FACTORY STANDARD<br/>-FACTORY OPTION<br/>-FIELD INSTALLED</p> <p>REPLACEMENT WIRE<br/>-MUST BE THE SAME SIZE AND TYPE OF INSULATION AS ORIGINAL (105 C° MIN.)<br/>WARNING<br/>-CABINET MUST BE PERMANENTLY GROUNDED AND CONFORM TO I.E.C., N.E.C., C.E.C. AND LOCAL CODES AS APPLICABLE.</p> | <p><b>WIRE COLOR CODE</b></p> <p>BK BLACK<br/>BR BROWN<br/>BL BLUE<br/>G GREEN<br/>GY GRAY<br/>O ORANGE<br/>PK PINK<br/>PR PURPLE<br/>R RED<br/>W WHITE<br/>Y YELLOW</p>  |  |
| <p><b>ELECTRICAL WIRING DIAGRAM</b><br/>208/230/460/575V, 3 PHASE, 60 HZ.<br/>200/220/380/415V, 3 PHASE, 50 HZ.<br/>BELT DRIVE<br/>PACKAGE AIR CONDITIONER</p>   |   | <p>DR. BY: APP. BY: DATE: DRG. NO. REV. NO.<br/>JRJ 12-22-04 90-23597-23 03</p>  | <p><b>WIRING SCHEMATIC</b></p> <p>L1 L2 L3</p> <p>CC T1 T2 T3</p> <p>LAC (OPT)</p> <p>OPM</p> <p>CM</p> <p>BC</p> <p>IBM</p> <p>24V</p> <p>CT</p> <p>PL2 TO ECONOMIZER</p> <p>R Y1 G Y2 C</p> <p>SEE NOTE 9</p> |  |

