



The new degree of comfort.™

Rheem *Commercial Classic*® Series Package Gas Electric Unit



RKNN- 13 SEER Series
RKPN- 14 SEER Series
RKQN- 15 SEER Series
Nominal Sizes 3-5 Tons [10.6-17.6 kW]



"Proper sizing and installation of equipment is critical to achieve optimal performance. Ask your Contractor for details or visit www.energystar.gov."



TABLE OF CONTENTS

Unit Features & Benefits	3-4
Model Number Identification	5
Options	6
Selection Procedure	7
General Data	
RKNN- Series	8-21
RKPN- Series	22-35
RKQN- Series	36-47
General Data Notes	48
Gross Systems Performance Data	
RKNN- Series	49-51
RKPN- Series	52-54
RKQN- Series	55-57
Indoor Airflow Performance	58-67
Electrical Data	
RKNN- Series	68-70
RKPN- Series	71-73
RKQN- Series	74-75
Dimensional Data	76-78
Accessories	79-87
Mechanical Specifications	88-92
Wiring Diagrams	93-106
Limited Warranty	107



RKNN - A036, A048, A060
RKPN - A036, A048, A060
RKQN - A036, A048, A060

RKNN-/RKPN-/RKQN- STANDARD FEATURES INCLUDE:

- R-410A HFC refrigerant.
- Complete factory charged, wired and run tested.
- Scroll compressors with internal line break overload and high-pressure protection.
- Single stage compressor on all models (except RKQN-A060 two stage Ultra Tech).
- Convertible airflow.
- TXV refrigerant metering system on each circuit.
- High Pressure and Low Pressure/Loss of charge protection standard on all models.
- Solid Core liquid line filter drier on each circuit.
- Single slab, Micro Channel designed evaporator coil facilitate easy cleaning for maintained high efficiencies.
- Cooling operation up to 125 degree F ambient.
- Easily removable filter, blower, gas heat, and compressor/control access panels permits prompt service.
- Powder Paint Finish meets ASTM B117 steel coated on each side for maximum protection. G90 galvanized.
- One piece top cover and one piece base pan with drawn supply and return opening for superior water management.
- Externally mounted refrigerant gauge ports for easy service diagnostics.
- Easy to install plug-in; slip in, 100% fully modulating economizer.
- Forkable base rails for easy handling and lifting.
- Single point electrical and gas connections.
- Direct drive or high performance belt drive motor with variable pitch pulleys and quick adjust belt system.
- Permanently lubricated evaporator, condenser and gas heat inducer motors.
- Condenser motors are internally protected, totally enclosed with shaft down design.
- 1 inch filter standard with slide out design. Will accept 2 inch filter.
- Single stage gas valve, direct spark ignition, and induced draft for efficiency and reliability.
- Tubular heat exchange for long life and induced draft for efficiency and reliability.
- Solid state furnace control with on board diagnostics.
- Colored and labeled wiring.
- Molded compressor plug.
- Through the base gas and electric.
- Micro Channel evaporators and condenser delivers superior performance with less refrigerant charge and less weight than conventional copper tube/aluminum fin coils. In addition the all aluminum design has superior formicary corrosion protection and less potential for leaks due to elimination of tube rubbing potential. Its easier to clean and has a more robust surface.



Package Gas Electric Unit Features:

Evaporator Coil/Filter Access

- Return air filters, normally provided, are removed in this photo.



- Non-corrosive plastic condensate pan



Tubular Heat Exchanger

- Aluminized steel (viewed from supply air side panel.)
- Stainless steel available

Control Box Access



Compressor Access (3 to 5 Ton [10.6 to 17.6 kW] Models)

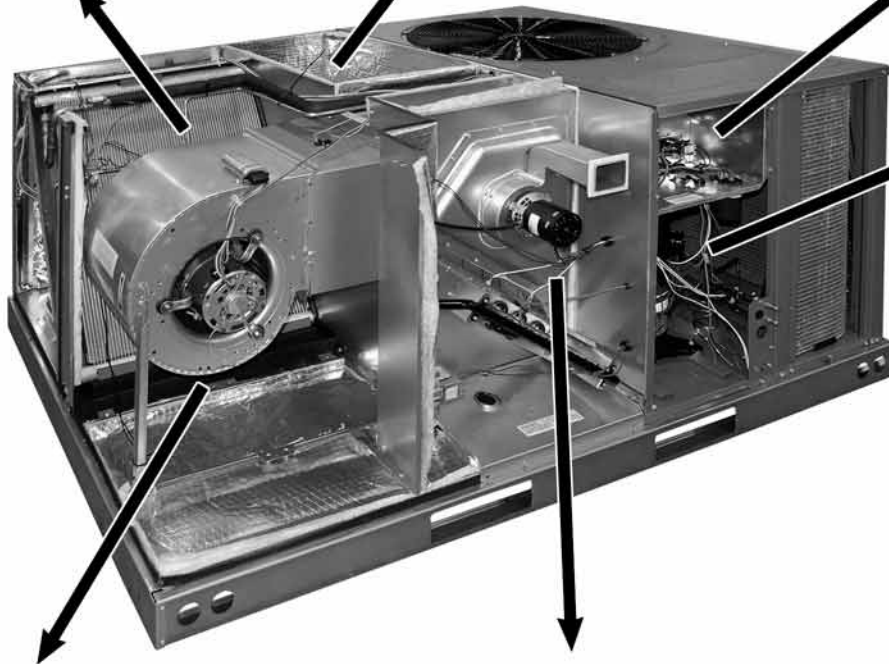

Blower Access

- Belt drive model shown. (Available on 3-phase models only.)

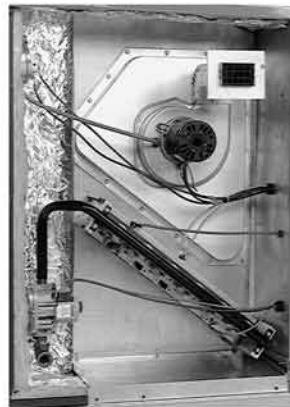

Heating Compartment Access

[] Designates Metric Conversions



R K N N — A 036 J K 08 E X X X

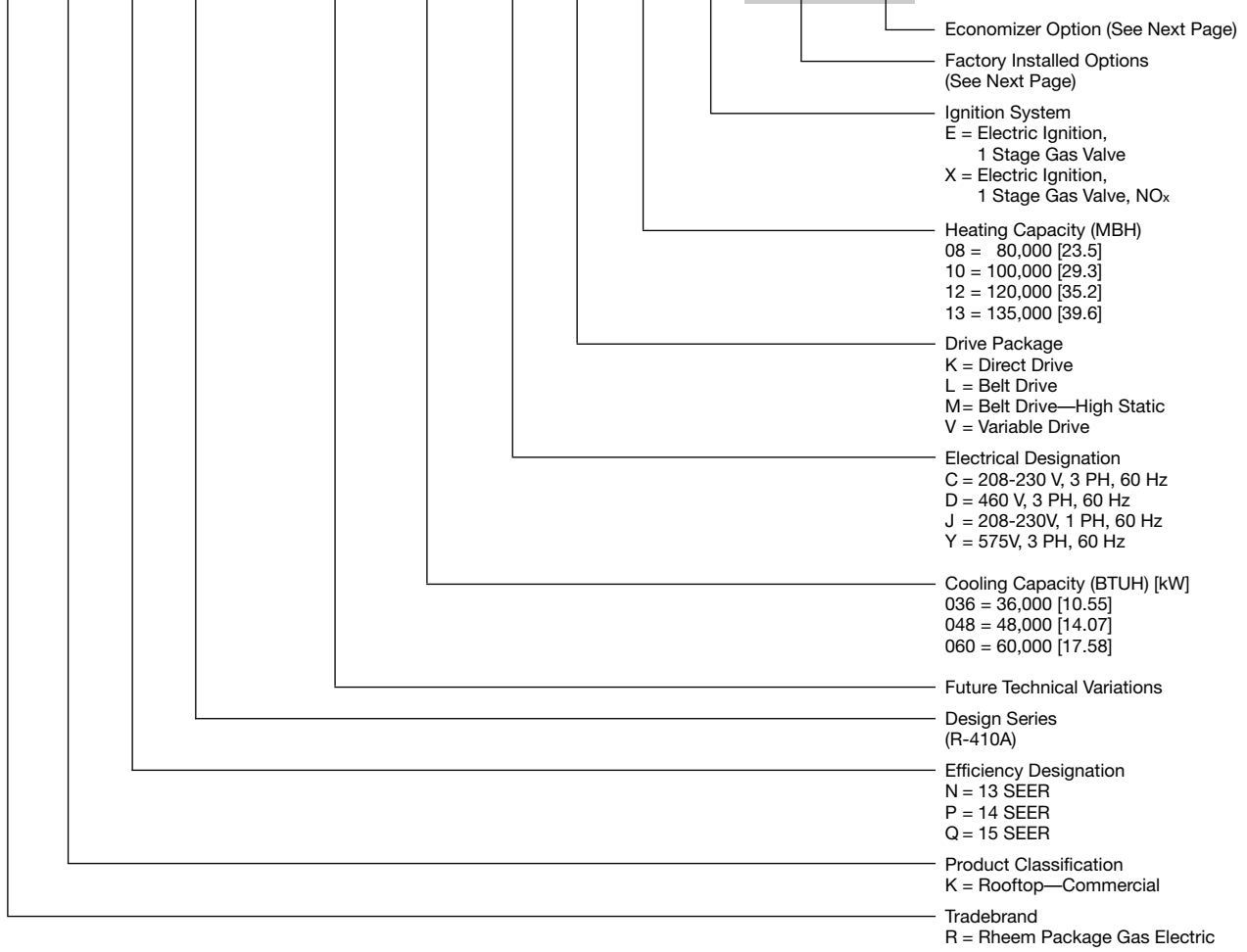

[] Designates Metric Conversions



FACTORY INSTALLED OPTION CODES FOR RKNN/RKPN/RKQN (3-5 TON) [10.6-17.6 kW] (A036, A048, A060)

Option Code	Hail Guard	Stainless Steel Heat Exchanger	Non-Powered Convenience Outlet/Unfused Service Disconnect	Low Ambient/ Freeze Stat
AD	x			
AJ		x		
AH			x	
AP				x
BF	x		x	
BG	x	x		
BY	x			x
JB		x	x	
CR	x	x		x
DN	x	x	x	x

Economizer Codes

A = No Economizer

F = Economizer with Single Enthalpy

Example: RKNN-A060JK13E**XX** (where **XX** is factory installed option)

Example: No Options

RKNN-A060JK13E

Example: No option with factory installed economizer

RKNN-A060JK13EAAF

Example: Options with stainless steel heat exchanger and no factory installed economizer

RKNN-A060JK13EAJA

Example: Options same as above with factory installed economizer

RKNN-A060JK13EAJF

ECONOMIZER SELECTION FOR RKNN/RKPN/RKQN (3-5 TON) [10.6-17.6 kW]

	No Economizer	Single Enthalpy Economizer with Barometric Relief	Single Enthalpy Economizer with Smoke Detector
A	x		
F		x	
G			x

"x" indicates factory installed option.

[] Designates Metric Conversions

1. Determine cooling and heating requirements at design conditions.

Example:

Power Supply	208/230-3 Phase
Total cooling capacity	42,500 BTUH [12.44 kW]
Sensible cooling capacity	34,000 BTUH [9.96 kW]
Heating capacity	96,000 BTUH [28.13 kW]
Condenser entering air	95°F [35°C]
Evaporator entering air	63°F [17°C] wb/76°F [24°C] db
Indoor air flow	1600 CFM [755 L/s]
External static pressure	1.1 in wg
Required efficiency	13 SEER

2. Select unit to meet cooling requirements.

Since total cooling is within the range of 4 ton [14.07 kW] unit and requires 13 SEER efficiency level, enter cooling performance from the RKNN-A048 at 95°F [35°C] outdoor temperature, 63°F [17°C] wb entering indoor air, and 1600 CFM [755 L/s]:

Total capacity	45,100 BTUH [13.21 kW]
Sensible capacity	44,100 BTUH [12.01 kW]
Power input	3.6 kW

And also, at 76°F [24°C] db indoor entering air, and using the formula at the bottom of the table:

Sensible capacity	38,327 BTUH [11.22 kW]
-------------------------	------------------------

3. Select heating capacity of the unit.

In the general data tables, note that the heating capacity of the 4 ton [14.07 kW] model with the 135,000 input heater can deliver 109,400 BTUH [32.03 kW], which is suitable for this application.

4. Determine blower speed and power to meet the system requirements.

At the given external static pressure of 1.1 in wg, the belt model must be selected. Enter the belt drive blower performance data at 1600 CFM [755 L/s] and 1.1 in wg ESP:

RPM	1195
Watts	755
Drive	M

5. Calculate indoor blower BTUH heat effect.

$$\text{BTUH} = \text{Watts} \times 3.413 = 2577$$

6. Calculate net cooling capacities.

$$\begin{aligned} \text{Net total cooling} &= 45,100 - 2577 = 42,523 \text{ BTUH [12.45 kW]} \\ \text{Net sensible cooling} &= 41,708 - 2577 = 39,131 \text{ BTUH [11.45 kW]} \end{aligned}$$

7. Select model

RKNN-A048CM13E

[] Designates Metric Conversions

NOM. SIZES 3-5 TONS [10.6-17.6 kW]

Model RKNN- Series	A036CK08	A036CK12	A036CL08	A036CL12
Cooling Performance¹				CONTINUED →
Gross Cooling Capacity Btu [kW]	36,200 [10.61]	36,200 [10.61]	36,200 [10.61]	36,200 [10.61]
EER/SEER ²	11.5/13	11.5/13	11.5/13	11.5/13
Nominal CFM/AHRI Rated CFM [L/s]	1200/1250 [566/590]	1200/1250 [566/590]	1200/1250 [566/590]	1200/1250 [566/590]
AHRI Net Cooling Capacity Btu [kW]	34,600 [10.14]	34,600 [10.14]	34,600 [10.14]	34,600 [10.14]
Net Sensible Capacity Btu [kW]	25,300 [7.41]	25,300 [7.41]	25,300 [7.41]	25,300 [7.41]
Net Latent Capacity Btu [kW]	9,300 [2.72]	9,300 [2.72]	9,300 [2.72]	9,300 [2.72]
Net System Power kW	2.93	2.93	2.93	2.93
Heating Performance (Gas)³				
Heating Input Btu [kW]	80,000 [23.44]	120,000 [35.16]	80,000 [23.44]	120,000 [35.16]
Heating Output Btu [kW]	64,800 [18.99]	97,200 [28.48]	64,800 [18.99]	97,200 [28.48]
Temperature Rise Range °F [°C]	30-60 [16.7-33.3]	50-80 [27.8-44.4]	30-60 [16.7-33.3]	50-80 [27.8-44.4]
AFUE %	80	80	80	80
Steady State Efficiency (%)	81	81	81	81
No. Burners	4	6	4	6
No. Stages	1	1	1	1
Gas Connection Pipe Size in. [mm]	0.5 [12.7]	0.5 [12.7]	0.5 [12.7]	0.5 [12.7]
Compressor				
No./Type	1/Scroll	1/Scroll	1/Scroll	1/Scroll
Outdoor Sound Rating (dB)⁴	78	78	78	78
Outdoor Coil—Fin Type	Louvered	Louvered	Louvered	Louvered
Tube Type	MicroChannel	MicroChannel	MicroChannel	MicroChannel
MicroChannel Depth in. [mm]	0.7 [18]	0.7 [18]	0.7 [18]	0.7 [18]
Face Area sq. ft. [sq. m]	13.9 [1.29]	13.9 [1.29]	13.9 [1.29]	13.9 [1.29]
Rows / FPI [FPcm]	1 / 23 [9]	1 / 23 [9]	1 / 23 [9]	1 / 23 [9]
Indoor Coil—Fin Type	Louvered	Louvered	Louvered	Louvered
Tube Type	MicroChannel	MicroChannel	MicroChannel	MicroChannel
MicroChannel Depth in. [mm]	1 [25]	1 [25]	1 [25]	1 [25]
Face Area sq. ft. [sq. m]	4.8 [0.45]	4.8 [0.45]	4.8 [0.45]	4.8 [0.45]
Rows / FPI [FPcm]	1 / 20 [8]	1 / 20 [8]	1 / 20 [8]	1 / 20 [8]
Refrigerant Control	TX Valves	TX Valves	TX Valves	TX Valves
Drain Connection No./Size in. [mm]	1/0.75 [19.05]	1/0.75 [19.05]	1/0.75 [19.05]	1/0.75 [19.05]
Outdoor Fan—Type	Propeller	Propeller	Propeller	Propeller
No. Used/Diameter in. [mm]	1/24 [609.6]	1/24 [609.6]	1/24 [609.6]	1/24 [609.6]
Drive Type/No. Speeds	Direct/1	Direct/1	Direct/1	Direct/1
CFM [L/s]	3680 [1737]	3680 [1737]	3680 [1737]	3680 [1737]
No. Motors/HP	1 at 1/3 HP	1 at 1/3 HP	1 at 1/3 HP	1 at 1/3 HP
Motor RPM	1075	1075	1075	1075
Indoor Fan—Type	FC Centrifugal	FC Centrifugal	FC Centrifugal	FC Centrifugal
No. Used/Diameter in. [mm]	1/10x10 [254x254]	1/10x10 [254x254]	1/10x10 [254x254]	1/10x10 [254x254]
Drive Type	Direct	Direct	Belt (Adjustable)	Belt (Adjustable)
No. Speeds	Multiple	Multiple	Single	Single
No. Motors	1	1	1	1
Motor HP	1/2	1/2	1/2	1/2
Motor RPM	1075	1075	1725	1725
Motor Frame Size	48	48	48	48
Filter—Type	Disposable	Disposable	Disposable	Disposable
Furnished	Yes	Yes	Yes	Yes
(NO.) Size Recommended in. [mm x mm x mm]	(1)1x16x25 [25x406x635]	(1)1x16x25 [25x406x635]	(1)1x16x25 [25x406x635]	(1)1x16x25 [25x406x635]
	(1)1x16x25 [25x406x635]	(1)1x16x25 [25x406x635]	(1)1x16x25 [25x406x635]	(1)1x16x25 [25x406x635]
Refrigerant Charge Oz. [g]	54 [1531]	54 [1531]	54 [1531]	54 [1531]
Weights				
Net Weight lbs. [kg]	507 [230]	517 [235]	525 [238]	517 [235]
Ship Weight lbs. [kg]	514 [233]	525 [238]	532 [241]	525 [238]

See Page 48 for Notes.

[] Designates Metric Conversions

NOM. SIZES 3-5 TONS [10.6-17.6 kW]

Model RKNN- Series	A036CM08	A036CM12	A036DK08	A036DK12
Cooling Performance¹				CONTINUED →
Gross Cooling Capacity Btu [kW]	36,200 [10.61]	36,200 [10.61]	36,200 [10.61]	36,200 [10.61]
EER/SEER ²	11.5/13	11.5/13	11.5/13	11.5/13
Nominal CFM/AHRI Rated CFM [L/s]	1200/1250 [566/590]	1200/1250 [566/590]	1200/1250 [566/590]	1200/1250 [566/590]
AHRI Net Cooling Capacity Btu [kW]	34,600 [10.14]	34,600 [10.14]	34,600 [10.14]	34,600 [10.14]
Net Sensible Capacity Btu [kW]	25,300 [7.41]	25,300 [7.41]	25,300 [7.41]	25,300 [7.41]
Net Latent Capacity Btu [kW]	9,300 [2.72]	9,300 [2.72]	9,300 [2.72]	9,300 [2.72]
Net System Power kW	2.93	2.93	2.93	2.93
Heating Performance (Gas)³				
Heating Input Btu [kW]	80,000 [23.44]	120,000 [35.16]	80,000 [23.44]	120,000 [35.16]
Heating Output Btu [kW]	64,800 [18.99]	97,200 [28.48]	64,800 [18.99]	97,200 [28.48]
Temperature Rise Range °F [°C]	30-60 [16.7-33.3]	50-80 [27.8-44.4]	30-60 [16.7-33.3]	50-80 [27.8-44.4]
AFUE %	80	80	80	80
Steady State Efficiency (%)	81	81	81	81
No. Burners	4	6	4	6
No. Stages	1	1	1	1
Gas Connection Pipe Size in. [mm]	0.5 [12.7]	0.5 [12.7]	0.5 [12.7]	0.5 [12.7]
Compressor				
No./Type	1/Scroll	1/Scroll	1/Scroll	1/Scroll
Outdoor Sound Rating (dB)⁴	78	78	78	78
Outdoor Coil—Fin Type	Louvered	Louvered	Louvered	Louvered
Tube Type	MicroChannel	MicroChannel	MicroChannel	MicroChannel
MicroChannel Depth in. [mm]	0.7 [18]	0.7 [18]	0.7 [18]	0.7 [18]
Face Area sq. ft. [sq. m]	13.9 [1.29]	13.9 [1.29]	13.9 [1.29]	13.9 [1.29]
Rows / FPI [FPcm]	1 / 23 [9]	1 / 23 [9]	1 / 23 [9]	1 / 23 [9]
Indoor Coil—Fin Type	Louvered	Louvered	Louvered	Louvered
Tube Type	MicroChannel	MicroChannel	MicroChannel	MicroChannel
MicroChannel Depth in. [mm]	1 [25]	1 [25]	1 [25]	1 [25]
Face Area sq. ft. [sq. m]	4.8 [0.45]	4.8 [0.45]	4.8 [0.45]	4.8 [0.45]
Rows / FPI [FPcm]	1 / 20 [8]	1 / 20 [8]	1 / 20 [8]	1 / 20 [8]
Refrigerant Control	TX Valves	TX Valves	TX Valves	TX Valves
Drain Connection No./Size in. [mm]	1/0.75 [19.05]	1/0.75 [19.05]	1/0.75 [19.05]	1/0.75 [19.05]
Outdoor Fan—Type	Propeller	Propeller	Propeller	Propeller
No. Used/Diameter in. [mm]	1/24 [609.6]	1/24 [609.6]	1/24 [609.6]	1/24 [609.6]
Drive Type/No. Speeds	Direct/1	Direct/1	Direct/1	Direct/1
CFM [L/s]	3680 [1737]	3680 [1737]	3680 [1737]	3680 [1737]
No. Motors/HP	1 at 1/3 HP	1 at 1/3 HP	1 at 1/3 HP	1 at 1/3 HP
Motor RPM	1075	1075	1075	1075
Indoor Fan—Type	FC Centrifugal	FC Centrifugal	FC Centrifugal	FC Centrifugal
No. Used/Diameter in. [mm]	1/10x10 [254x254]	1/10x10 [254x254]	1/10x10 [254x254]	1/10x10 [254x254]
Drive Type	Belt (Adjustable)	Belt (Adjustable)	Direct	Direct
No. Speeds	Single	Single	Multiple	Multiple
No. Motors	1	1	1	1
Motor HP	1/2	1/2	1/2	1/2
Motor RPM	1725	1725	1075	1075
Motor Frame Size	48	48	48	48
Filter—Type	Disposable	Disposable	Disposable	Disposable
Furnished	Yes	Yes	Yes	Yes
(NO.) Size Recommended in. [mm x mm x mm]	(1)1x16x25 [25x406x635] (1)1x16x25 [25x406x635]	(1)1x16x25 [25x406x635] (1)1x16x25 [25x406x635]	(1)1x16x25 [25x406x635] (1)1x16x25 [25x406x635]	(1)1x16x25 [25x406x635] (1)1x16x25 [25x406x635]
Refrigerant Charge Oz. [g]	54 [1531]	54 [1531]	54 [1531]	54 [1531]
Weights				
Net Weight lbs. [kg]	525 [238]	517 [235]	507 [230]	517 [235]
Ship Weight lbs. [kg]	532 [241]	525 [238]	514 [233]	525 [238]

See Page 48 for Notes.

[] Designates Metric Conversions



NOM. SIZES 3-5 TONS [10.6-17.6 kW]

Model RKNN- Series	A036DL08	A036DL12	A036DM08	A036DM12
Cooling Performance¹				CONTINUED →
Gross Cooling Capacity Btu [kW]	36,200 [10.61]	36,200 [10.61]	36,200 [10.61]	36,200 [10.61]
EER/SEER ²	11.5/13	11.5/13	11.5/13	11.5/13
Nominal CFM/AHRI Rated CFM [L/s]	1200/1250 [566/590]	1200/1250 [566/590]	1200/1250 [566/590]	1200/1250 [566/590]
AHRI Net Cooling Capacity Btu [kW]	34,600 [10.14]	34,600 [10.14]	34,600 [10.14]	34,600 [10.14]
Net Sensible Capacity Btu [kW]	25,300 [7.41]	25,300 [7.41]	25,300 [7.41]	25,300 [7.41]
Net Latent Capacity Btu [kW]	9,300 [2.72]	9,300 [2.72]	9,300 [2.72]	9,300 [2.72]
Net System Power kW	2.93	2.93	2.93	2.93
Heating Performance (Gas)³				
Heating Input Btu [kW]	80,000 [23.44]	120,000 [35.16]	80,000 [23.44]	120,000 [35.16]
Heating Output Btu [kW]	64,800 [18.99]	97,200 [28.48]	64,800 [18.99]	97,200 [28.48]
Temperature Rise Range °F [°C]	30-60 [16.7-33.3]	50-80 [27.8-44.4]	30-60 [16.7-33.3]	50-80 [27.8-44.4]
AFUE %	80	80	80	80
Steady State Efficiency (%)	81	81	81	81
No. Burners	4	6	4	6
No. Stages	1	1	1	1
Gas Connection Pipe Size in. [mm]	0.5 [12.7]	0.5 [12.7]	0.5 [12.7]	0.5 [12.7]
Compressor				
No./Type	1/Scroll	1/Scroll	1/Scroll	1/Scroll
Outdoor Sound Rating (dB)⁴	78	78	78	78
Outdoor Coil—Fin Type	Louvered	Louvered	Louvered	Louvered
Tube Type	MicroChannel	MicroChannel	MicroChannel	MicroChannel
MicroChannel Depth in. [mm]	0.7 [18]	0.7 [18]	0.7 [18]	0.7 [18]
Face Area sq. ft. [sq. m]	13.9 [1.29]	13.9 [1.29]	13.9 [1.29]	13.9 [1.29]
Rows / FPI [FPcm]	1 / 23 [9]	1 / 23 [9]	1 / 23 [9]	1 / 23 [9]
Indoor Coil—Fin Type	Louvered	Louvered	Louvered	Louvered
Tube Type	MicroChannel	MicroChannel	MicroChannel	MicroChannel
MicroChannel Depth in. [mm]	1 [25]	1 [25]	1 [25]	1 [25]
Face Area sq. ft. [sq. m]	4.8 [0.45]	4.8 [0.45]	4.8 [0.45]	4.8 [0.45]
Rows / FPI [FPcm]	1 / 20 [8]	1 / 20 [8]	1 / 20 [8]	1 / 20 [8]
Refrigerant Control	TX Valves	TX Valves	TX Valves	TX Valves
Drain Connection No./Size in. [mm]	1/0.75 [19.05]	1/0.75 [19.05]	1/0.75 [19.05]	1/0.75 [19.05]
Outdoor Fan—Type	Propeller	Propeller	Propeller	Propeller
No. Used/Diameter in. [mm]	1/24 [609.6]	1/24 [609.6]	1/24 [609.6]	1/24 [609.6]
Drive Type/No. Speeds	Direct/1	Direct/1	Direct/1	Direct/1
CFM [L/s]	3680 [1737]	3680 [1737]	3680 [1737]	3680 [1737]
No. Motors/HP	1 at 1/3 HP	1 at 1/3 HP	1 at 1/3 HP	1 at 1/3 HP
Motor RPM	1075	1075	1075	1075
Indoor Fan—Type	FC Centrifugal	FC Centrifugal	FC Centrifugal	FC Centrifugal
No. Used/Diameter in. [mm]	1/10x10 [254x254]	1/10x10 [254x254]	1/10x10 [254x254]	1/10x10 [254x254]
Drive Type	Belt (Adjustable)	Belt (Adjustable)	Belt (Adjustable)	Belt (Adjustable)
No. Speeds	Single	Single	Single	Single
No. Motors	1	1	1	1
Motor HP	1/2	1/2	1/2	1/2
Motor RPM	1725	1725	1725	1725
Motor Frame Size	48	48	48	48
Filter—Type	Disposable	Disposable	Disposable	Disposable
Furnished	Yes	Yes	Yes	Yes
(NO.) Size Recommended in. [mm x mm x mm]	(1)1x16x25 [25x406x635]	(1)1x16x25 [25x406x635]	(1)1x16x25 [25x406x635]	(1)1x16x25 [25x406x635]
	(1)1x16x25 [25x406x635]	(1)1x16x25 [25x406x635]	(1)1x16x25 [25x406x635]	(1)1x16x25 [25x406x635]
Refrigerant Charge Oz. [g]	54 [1531]	54 [1531]	54 [1531]	54 [1531]
Weights				
Net Weight lbs. [kg]	525 [238]	517 [235]	525 [238]	517 [235]
Ship Weight lbs. [kg]	532 [241]	525 [238]	532 [241]	525 [238]

See Page 48 for Notes.

[] Designates Metric Conversions

NOM. SIZES 3-5 TONS [10.6-17.6 kW]

Model RKNN- Series	A036JK08	A036JK12	A036YL12	A036YM12
Cooling Performance¹				CONTINUED →
Gross Cooling Capacity Btu [kW]	36,200 [10.61]	36,200 [10.61]	36,200 [10.61]	36,200 [10.61]
EER/SEER ²	11.5/13	11.5/13	11.5/13	11.5/13
Nominal CFM/AHRI Rated CFM [L/s]	1200/1250 [566/590]	1200/1250 [566/590]	1200/1250 [566/590]	1200/1250 [566/590]
AHRI Net Cooling Capacity Btu [kW]	34,600 [10.14]	34,600 [10.14]	34,600 [10.14]	34,600 [10.14]
Net Sensible Capacity Btu [kW]	25,300 [7.41]	25,300 [7.41]	25,300 [7.41]	25,300 [7.41]
Net Latent Capacity Btu [kW]	9,300 [2.72]	9,300 [2.72]	9,300 [2.72]	9,300 [2.72]
Net System Power kW	2.93	2.93	2.93	2.93
Heating Performance (Gas)³				
Heating Input Btu [kW]	80,000 [23.44]	120,000 [35.16]	120,000 [35.16]	120,000 [35.16]
Heating Output Btu [kW]	64,000 [18.76]	96,000 [28.13]	97,200 [28.48]	97,200 [28.48]
Temperature Rise Range °F [°C]	30-60 [16.7-33.3]	50-80 [27.8-44.4]	50-80 [27.8-44.4]	50-80 [27.8-44.4]
AFUE %	80	80	80	80
Steady State Efficiency (%)	80	80	81	81
No. Burners	4	6	6	6
No. Stages	1	1	1	1
Gas Connection Pipe Size in. [mm]	0.5 [12.7]	0.5 [12.7]	0.5 [12.7]	0.5 [12.7]
Compressor				
No./Type	1/Scroll	1/Scroll	1/Scroll	1/Scroll
Outdoor Sound Rating (dB)⁴	78	78	78	78
Outdoor Coil—Fin Type	Louvered	Louvered	Louvered	Louvered
Tube Type	MicroChannel	MicroChannel	MicroChannel	MicroChannel
MicroChannel Depth in. [mm]	0.7 [18]	0.7 [18]	0.7 [18]	0.7 [18]
Face Area sq. ft. [sq. m]	13.9 [1.29]	13.9 [1.29]	13.9 [1.29]	13.9 [1.29]
Rows / FPI [FPcm]	1 / 23 [9]	1 / 23 [9]	1 / 23 [9]	1 / 23 [9]
Indoor Coil—Fin Type	Louvered	Louvered	Louvered	Louvered
Tube Type	MicroChannel	MicroChannel	MicroChannel	MicroChannel
MicroChannel Depth in. [mm]	1 [25]	1 [25]	1 [25]	1 [25]
Face Area sq. ft. [sq. m]	4.8 [0.45]	4.8 [0.45]	4.8 [0.45]	4.8 [0.45]
Rows / FPI [FPcm]	1 / 20 [8]	1 / 20 [8]	1 / 20 [8]	1 / 20 [8]
Refrigerant Control	TX Valves	TX Valves	TX Valves	TX Valves
Drain Connection No./Size in. [mm]	1/0.75 [19.05]	1/0.75 [19.05]	1/0.75 [19.05]	1/0.75 [19.05]
Outdoor Fan—Type	Propeller	Propeller	Propeller	Propeller
No. Used/Diameter in. [mm]	1/24 [609.6]	1/24 [609.6]	1/24 [609.6]	1/24 [609.6]
Drive Type/No. Speeds	Direct/1	Direct/1	Direct/1	Direct/1
CFM [L/s]	3680 [1737]	3680 [1737]	3680 [1737]	3680 [1737]
No. Motors/HP	1 at 1/3 HP	1 at 1/3 HP	1 at 1/3 HP	1 at 1/3 HP
Motor RPM	1075	1075	1075	1075
Indoor Fan—Type	FC Centrifugal	FC Centrifugal	FC Centrifugal	FC Centrifugal
No. Used/Diameter in. [mm]	1/10x10 [254x254]	1/10x10 [254x254]	1/10x10 [254x254]	1/10x10 [254x254]
Drive Type	Direct	Direct	Belt (Adjustable)	Belt (Adjustable)
No. Speeds	Multiple	Multiple	Single	Single
No. Motors	1	1	1	1
Motor HP	1/2	1/2	3/4	3/4
Motor RPM	1075	1075	1725	1725
Motor Frame Size	48	48	56	56
Filter—Type	Disposable	Disposable	Disposable	Disposable
Furnished	Yes	Yes	Yes	Yes
(NO.) Size Recommended in. [mm x mm x mm]	(1)1x16x25 [25x406x635]	(1)1x16x25 [25x406x635]	(1)1x16x25 [25x406x635]	(1)1x16x25 [25x406x635]
	(1)1x16x25 [25x406x635]	(1)1x16x25 [25x406x635]	(1)1x16x25 [25x406x635]	(1)1x16x25 [25x406x635]
Refrigerant Charge Oz. [g]	54 [1531]	54 [1531]	54 [1531]	54 [1531]
Weights				
Net Weight lbs. [kg]	507 [230]	517 [235]	517 [235]	517 [235]
Ship Weight lbs. [kg]	514 [233]	525 [238]	525 [238]	525 [238]

See Page 48 for Notes.

[] Designates Metric Conversions



NOM. SIZES 3-5 TONS [10.6-17.6 kW]

Model RKNN- Series	A048CK08	A048CK10	A048CK13	A048CL08
Cooling Performance¹				CONTINUED →
Gross Cooling Capacity Btu [kW]	48,000 [14.06]	48,000 [14.06]	48,000 [14.06]	48,000 [14.06]
EER/SEER ²	11.5/13	11.5/13	11.5/13	11.5/13
Nominal CFM/AHRI Rated CFM [L/s]	1600/1500 [755/708]	1600/1500 [755/708]	1600/1500 [755/708]	1600/1500 [755/708]
AHRI Net Cooling Capacity Btu [kW]	46,000 [13.48]	46,000 [13.48]	46,000 [13.48]	46,000 [13.48]
Net Sensible Capacity Btu [kW]	34,000 [9.96]	34,000 [9.96]	34,000 [9.96]	34,000 [9.96]
Net Latent Capacity Btu [kW]	12,000 [3.52]	12,000 [3.52]	12,000 [3.52]	12,000 [3.52]
Net System Power kW	3.93	3.93	3.93	3.93
Heating Performance (Gas)³				
Heating Input Btu [kW]	80,000 [23.44]	100,000 [29.3]	135,000 [39.55]	80,000 [23.44]
Heating Output Btu [kW]	64,800 [18.99]	81,000 [23.73]	109,400 [32.05]	64,800 [18.99]
Temperature Rise Range °F [°C]	30-60 [16.7-33.3]	40-70 [22.2-38.9]	50-80 [27.8-44.4]	30-60 [16.7-33.3]
AFUE %	80	80	80	80
Steady State Efficiency (%)	81	81	81	81
No. Burners	4	5	6	4
No. Stages	1	1	1	1
Gas Connection Pipe Size in. [mm]	0.5 [12.7]	0.5 [12.7]	0.5 [12.7]	0.5 [12.7]
Compressor				
No./Type	1/Scroll	1/Scroll	1/Scroll	1/Scroll
Outdoor Sound Rating (dB)⁴	78	78	78	78
Outdoor Coil—Fin Type	Louvered	Louvered	Louvered	Louvered
Tube Type	MicroChannel	MicroChannel	MicroChannel	MicroChannel
MicroChannel Depth in. [mm]	0.7 [18]	0.7 [18]	0.7 [18]	0.7 [18]
Face Area sq. ft. [sq. m]	16.4 [1.52]	16.4 [1.52]	16.4 [1.52]	16.4 [1.52]
Rows / FPI [FPcm]	1 / 23 [9]	1 / 23 [9]	1 / 23 [9]	1 / 23 [9]
Indoor Coil—Fin Type	Louvered	Louvered	Louvered	Louvered
Tube Type	MicroChannel	MicroChannel	MicroChannel	MicroChannel
MicroChannel Depth in. [mm]	1.3 [32]	1.3 [32]	1.3 [32]	1.3 [32]
Face Area sq. ft. [sq. m]	4.8 [0.45]	4.8 [0.45]	4.8 [0.45]	4.8 [0.45]
Rows / FPI [FPcm]	1 / 20 [8]	1 / 20 [8]	1 / 20 [8]	1 / 20 [8]
Refrigerant Control	TX Valves	TX Valves	TX Valves	TX Valves
Drain Connection No./Size in. [mm]	1/0.75 [19.05]	1/0.75 [19.05]	1/0.75 [19.05]	1/0.75 [19.05]
Outdoor Fan—Type	Propeller	Propeller	Propeller	Propeller
No. Used/Diameter in. [mm]	1/24 [609.6]	1/24 [609.6]	1/24 [609.6]	1/24 [609.6]
Drive Type/No. Speeds	Direct/1	Direct/1	Direct/1	Direct/1
CFM [L/s]	3680 [1737]	3680 [1737]	3680 [1737]	3680 [1737]
No. Motors/HP	1 at 1/3 HP	1 at 1/3 HP	1 at 1/3 HP	1 at 1/3 HP
Motor RPM	1075	1075	1075	1075
Indoor Fan—Type	FC Centrifugal	FC Centrifugal	FC Centrifugal	FC Centrifugal
No. Used/Diameter in. [mm]	1/10x10 [254x254]	1/10x10 [254x254]	1/10x10 [254x254]	1/10x10 [254x254]
Drive Type	Direct	Direct	Direct	Belt (Adjustable)
No. Speeds	Multiple	Multiple	Multiple	Single
No. Motors	1	1	1	1
Motor HP	1/2	1/2	1/2	1/2
Motor RPM	1075	1075	1075	1725
Motor Frame Size	48	48	48	48
Filter—Type	Disposable	Disposable	Disposable	Disposable
Furnished	Yes	Yes	Yes	Yes
(NO.) Size Recommended in. [mm x mm x mm]	(1)1x16x25 [25x406x635] (1)1x16x25 [25x406x635]	(1)1x16x25 [25x406x635] (1)1x16x25 [25x406x635]	(1)1x16x25 [25x406x635] (1)1x16x25 [25x406x635]	(1)1x16x25 [25x406x635] (1)1x16x25 [25x406x635]
Refrigerant Charge Oz. [g]	68 [1928]	68 [1928]	68 [1928]	68 [1928]
Weights				
Net Weight lbs. [kg]	531 [241]	536 [243]	541 [245]	549 [249]
Ship Weight lbs. [kg]	538 [244]	543 [246]	548 [249]	556 [252]

See Page 48 for Notes.

[] Designates Metric Conversions

NOM. SIZES 3-5 TONS [10.6-17.6 kW]

Model RKNN- Series	A048CL10	A048CL13	A048CM08	A048CM10
Cooling Performance¹				CONTINUED →
Gross Cooling Capacity Btu [kW]	48,000 [14.06]	48,000 [14.06]	48,000 [14.06]	48,000 [14.06]
EER/SEER ²	11.5/13	11.5/13	11.5/13	11.5/13
Nominal CFM/AHRI Rated CFM [L/s]	1600/1500 [755/708]	1600/1500 [755/708]	1600/1500 [755/708]	1600/1500 [755/708]
AHRI Net Cooling Capacity Btu [kW]	46,000 [13.48]	46,000 [13.48]	46,000 [13.48]	46,000 [13.48]
Net Sensible Capacity Btu [kW]	34,000 [9.96]	34,000 [9.96]	34,000 [9.96]	34,000 [9.96]
Net Latent Capacity Btu [kW]	12,000 [3.52]	12,000 [3.52]	12,000 [3.52]	12,000 [3.52]
Net System Power kW	3.93	3.93	3.93	3.93
Heating Performance (Gas)³				
Heating Input Btu [kW]	100,000 [29.3]	135,000 [39.55]	80,000 [23.44]	100,000 [29.3]
Heating Output Btu [kW]	81,000 [23.73]	109,400 [32.05]	64,800 [18.99]	81,000 [23.73]
Temperature Rise Range °F [°C]	40-70 [22.2-38.9]	50-80 [27.8-44.4]	30-60 [16.7-33.3]	40-70 [22.2-38.9]
AFUE %	80	80	80	80
Steady State Efficiency (%)	81	81	81	81
No. Burners	5	6	4	5
No. Stages	1	1	1	1
Gas Connection Pipe Size in. [mm]	0.5 [12.7]	0.5 [12.7]	0.5 [12.7]	0.5 [12.7]
Compressor				
No./Type	1/Scroll	1/Scroll	1/Scroll	1/Scroll
Outdoor Sound Rating (dB)⁴	78	78	78	78
Outdoor Coil—Fin Type	Louvered	Louvered	Louvered	Louvered
Tube Type	MicroChannel	MicroChannel	MicroChannel	MicroChannel
MicroChannel Depth in. [mm]	0.7 [18]	0.7 [18]	0.7 [18]	0.7 [18]
Face Area sq. ft. [sq. m]	16.4 [1.52]	16.4 [1.52]	16.4 [1.52]	16.4 [1.52]
Rows / FPI [FPcm]	1 / 23 [9]	1 / 23 [9]	1 / 23 [9]	1 / 23 [9]
Indoor Coil—Fin Type	Louvered	Louvered	Louvered	Louvered
Tube Type	MicroChannel	MicroChannel	MicroChannel	MicroChannel
MicroChannel Depth in. [mm]	1.3 [32]	1.3 [32]	1.3 [32]	1.3 [32]
Face Area sq. ft. [sq. m]	4.8 [0.45]	4.8 [0.45]	4.8 [0.45]	4.8 [0.45]
Rows / FPI [FPcm]	1 / 20 [8]	1 / 20 [8]	1 / 20 [8]	1 / 20 [8]
Refrigerant Control	TX Valves	TX Valves	TX Valves	TX Valves
Drain Connection No./Size in. [mm]	1/0.75 [19.05]	1/0.75 [19.05]	1/0.75 [19.05]	1/0.75 [19.05]
Outdoor Fan—Type	Propeller	Propeller	Propeller	Propeller
No. Used/Diameter in. [mm]	1/24 [609.6]	1/24 [609.6]	1/24 [609.6]	1/24 [609.6]
Drive Type/No. Speeds	Direct/1	Direct/1	Direct/1	Direct/1
CFM [L/s]	3680 [1737]	3680 [1737]	3680 [1737]	3680 [1737]
No. Motors/HP	1 at 1/3 HP	1 at 1/3 HP	1 at 1/3 HP	1 at 1/3 HP
Motor RPM	1075	1075	1075	1075
Indoor Fan—Type	FC Centrifugal	FC Centrifugal	FC Centrifugal	FC Centrifugal
No. Used/Diameter in. [mm]	1/10x10 [254x254]	1/10x10 [254x254]	1/10x10 [254x254]	1/10x10 [254x254]
Drive Type	Belt (Adjustable)	Belt (Adjustable)	Belt (Adjustable)	Belt (Adjustable)
No. Speeds	Single	Single	Single	Single
No. Motors	1	1	1	1
Motor HP	1/2	1/2	3/4	3/4
Motor RPM	1725	1725	1725	1725
Motor Frame Size	48	48	56	56
Filter—Type	Disposable	Disposable	Disposable	Disposable
Furnished	Yes	Yes	Yes	Yes
(NO.) Size Recommended in. [mm x mm x mm]	(1)1x16x25 [25x406x635]	(1)1x16x25 [25x406x635]	(1)1x16x25 [25x406x635]	(1)1x16x25 [25x406x635]
	(1)1x16x25 [25x406x635]	(1)1x16x25 [25x406x635]	(1)1x16x25 [25x406x635]	(1)1x16x25 [25x406x635]
Refrigerant Charge Oz. [g]	68 [1928]	68 [1928]	68 [1928]	68 [1928]
Weights				
Net Weight lbs. [kg]	554 [251]	559 [254]	550 [249]	555 [252]
Ship Weight lbs. [kg]	561 [254]	566 [257]	557 [253]	562 [255]

See Page 48 for Notes.

[] Designates Metric Conversions

NOM. SIZES 3-5 TONS [10.6-17.6 kW]

Model RKNN- Series	A048CM13	A048DK08	A048DK10	A048DK13
Cooling Performance¹				CONTINUED →
Gross Cooling Capacity Btu [kW]	48,000 [14.06]	48,000 [14.06]	48,000 [14.06]	48,000 [14.06]
EER/SEER ²	11.5/13	11.5/13	11.5/13	11.5/13
Nominal CFM/AHRI Rated CFM [L/s]	1600/1500 [755/708]	1600/1500 [755/708]	1600/1500 [755/708]	1600/1500 [755/708]
AHRI Net Cooling Capacity Btu [kW]	46,000 [13.48]	46,000 [13.48]	46,000 [13.48]	46,000 [13.48]
Net Sensible Capacity Btu [kW]	34,000 [9.96]	34,000 [9.96]	34,000 [9.96]	34,000 [9.96]
Net Latent Capacity Btu [kW]	12,000 [3.52]	12,000 [3.52]	12,000 [3.52]	12,000 [3.52]
Net System Power kW	3.93	3.93	3.93	3.93
Heating Performance (Gas)³				
Heating Input Btu [kW]	135,000 [39.55]	80,000 [23.44]	100,000 [29.3]	135,000 [39.55]
Heating Output Btu [kW]	109,350 [32.04]	64,800 [18.99]	81,000 [23.73]	109,400 [32.05]
Temperature Rise Range °F [°C]	50-80 [27.8-44.4]	30-60 [16.7-33.3]	40-70 [22.2-38.9]	50-80 [27.8-44.4]
AFUE %	80	80	80	80
Steady State Efficiency (%)	81	81	81	81
No. Burners	6	4	5	6
No. Stages	1	1	1	1
Gas Connection Pipe Size in. [mm]	0.5 [12.7]	0.5 [12.7]	0.5 [12.7]	0.5 [12.7]
Compressor				
No./Type	1/Scroll	1/Scroll	1/Scroll	1/Scroll
Outdoor Sound Rating (dB)⁴	78	78	78	78
Outdoor Coil—Fin Type	Louvered	Louvered	Louvered	Louvered
Tube Type	MicroChannel	MicroChannel	MicroChannel	MicroChannel
MicroChannel Depth in. [mm]	0.7 [18]	0.7 [18]	0.7 [18]	0.7 [18]
Face Area sq. ft. [sq. m]	16.4 [1.52]	16.4 [1.52]	16.4 [1.52]	16.4 [1.52]
Rows / FPI [FPcm]	1 / 23 [9]	1 / 23 [9]	1 / 23 [9]	1 / 23 [9]
Indoor Coil—Fin Type	Louvered	Louvered	Louvered	Louvered
Tube Type	MicroChannel	MicroChannel	MicroChannel	MicroChannel
MicroChannel Depth in. [mm]	1.3 [32]	1.3 [32]	1.3 [32]	1.3 [32]
Face Area sq. ft. [sq. m]	4.8 [0.45]	4.8 [0.45]	4.8 [0.45]	4.8 [0.45]
Rows / FPI [FPcm]	1 / 20 [8]	1 / 20 [8]	1 / 20 [8]	1 / 20 [8]
Refrigerant Control	TX Valves	TX Valves	TX Valves	TX Valves
Drain Connection No./Size in. [mm]	1/0.75 [19.05]	1/0.75 [19.05]	1/0.75 [19.05]	1/0.75 [19.05]
Outdoor Fan—Type	Propeller	Propeller	Propeller	Propeller
No. Used/Diameter in. [mm]	1/24 [609.6]	1/24 [609.6]	1/24 [609.6]	1/24 [609.6]
Drive Type/No. Speeds	Direct/1	Direct/1	Direct/1	Direct/1
CFM [L/s]	3680 [1737]	3680 [1737]	3680 [1737]	3680 [1737]
No. Motors/HP	1 at 1/3 HP	1 at 1/3 HP	1 at 1/3 HP	1 at 1/3 HP
Motor RPM	1075	1075	1075	1075
Indoor Fan—Type	FC Centrifugal	FC Centrifugal	FC Centrifugal	FC Centrifugal
No. Used/Diameter in. [mm]	1/10x10 [254x254]	1/10x10 [254x254]	1/10x10 [254x254]	1/10x10 [254x254]
Drive Type	Belt (Adjustable)	Direct	Direct	Direct
No. Speeds	Single	Multiple	Multiple	Multiple
No. Motors	1	1	1	1
Motor HP	3/4	1/2	1/2	1/2
Motor RPM	1725	1075	1075	1075
Motor Frame Size	56	48	48	48
Filter—Type	Disposable	Disposable	Disposable	Disposable
Furnished	Yes	Yes	Yes	Yes
(NO.) Size Recommended in. [mm x mm x mm]	(1)1x16x25 [25x406x635] (1)1x16x25 [25x406x635]	(1)1x16x25 [25x406x635] (1)1x16x25 [25x406x635]	(1)1x16x25 [25x406x635] (1)1x16x25 [25x406x635]	(1)1x16x25 [25x406x635] (1)1x16x25 [25x406x635]
Refrigerant Charge Oz. [g]	68 [1928]	68 [1928]	68 [1928]	68 [1928]
Weights				
Net Weight lbs. [kg]	560 [254]	531 [241]	536 [243]	541 [245]
Ship Weight lbs. [kg]	567 [257]	538 [244]	543 [246]	548 [249]

See Page 48 for Notes.

[] Designates Metric Conversions

NOM. SIZES 3-5 TONS [10.6-17.6 kW]

Model RKNN- Series	A048DL08	A048DL10	A048DL13	A048DM08
Cooling Performance¹				CONTINUED →
Gross Cooling Capacity Btu [kW]	48,000 [14.06]	48,000 [14.06]	48,000 [14.06]	48,000 [14.06]
EER/SEER ²	11.5/13	11.5/13	11.5/13	11.5/13
Nominal CFM/AHRI Rated CFM [L/s]	1600/1500 [755/708]	1600/1500 [755/708]	1600/1500 [755/708]	1600/1500 [755/708]
AHRI Net Cooling Capacity Btu [kW]	46,000 [13.48]	46,000 [13.48]	46,000 [13.48]	46,000 [13.48]
Net Sensible Capacity Btu [kW]	34,000 [9.96]	34,000 [9.96]	34,000 [9.96]	34,000 [9.96]
Net Latent Capacity Btu [kW]	12,000 [3.52]	12,000 [3.52]	12,000 [3.52]	12,000 [3.52]
Net System Power kW	3.93	3.93	3.93	3.93
Heating Performance (Gas)³				
Heating Input Btu [kW]	80,000 [23.44]	100,000 [29.3]	135,000 [39.55]	80,000 [23.44]
Heating Output Btu [kW]	64,800 [18.99]	81,000 [23.73]	109,400 [32.05]	64,800 [18.99]
Temperature Rise Range °F [°C]	30-60 [16.7-33.3]	40-70 [22.2-38.9]	50-80 [27.8-44.4]	30-60 [16.7-33.3]
AFUE %	80	80	80	80
Steady State Efficiency (%)	81	81	81	81
No. Burners	4	5	6	4
No. Stages	1	1	1	1
Gas Connection Pipe Size in. [mm]	0.5 [12.7]	0.5 [12.7]	0.5 [12.7]	0.5 [12.7]
Compressor				
No./Type	1/Scroll	1/Scroll	1/Scroll	1/Scroll
Outdoor Sound Rating (dB)⁴	78	78	78	78
Outdoor Coil—Fin Type	Louvered	Louvered	Louvered	Louvered
Tube Type	MicroChannel	MicroChannel	MicroChannel	MicroChannel
MicroChannel Depth in. [mm]	0.7 [18]	0.7 [18]	0.7 [18]	0.7 [18]
Face Area sq. ft. [sq. m]	16.4 [1.52]	16.4 [1.52]	16.4 [1.52]	16.4 [1.52]
Rows / FPI [FPcm]	1 / 23 [9]	1 / 23 [9]	1 / 23 [9]	1 / 23 [9]
Indoor Coil—Fin Type	Louvered	Louvered	Louvered	Louvered
Tube Type	MicroChannel	MicroChannel	MicroChannel	MicroChannel
MicroChannel Depth in. [mm]	1.3 [32]	1.3 [32]	1.3 [32]	1.3 [32]
Face Area sq. ft. [sq. m]	4.8 [0.45]	4.8 [0.45]	4.8 [0.45]	4.8 [0.45]
Rows / FPI [FPcm]	1 / 20 [8]	1 / 20 [8]	1 / 20 [8]	1 / 20 [8]
Refrigerant Control	TX Valves	TX Valves	TX Valves	TX Valves
Drain Connection No./Size in. [mm]	1/0.75 [19.05]	1/0.75 [19.05]	1/0.75 [19.05]	1/0.75 [19.05]
Outdoor Fan—Type	Propeller	Propeller	Propeller	Propeller
No. Used/Diameter in. [mm]	1/24 [609.6]	1/24 [609.6]	1/24 [609.6]	1/24 [609.6]
Drive Type/No. Speeds	Direct/1	Direct/1	Direct/1	Direct/1
CFM [L/s]	3680 [1737]	3680 [1737]	3680 [1737]	3680 [1737]
No. Motors/HP	1 at 1/3 HP	1 at 1/3 HP	1 at 1/3 HP	1 at 1/3 HP
Motor RPM	1075	1075	1075	1075
Indoor Fan—Type	FC Centrifugal	FC Centrifugal	FC Centrifugal	FC Centrifugal
No. Used/Diameter in. [mm]	1/10x10 [254x254]	1/10x10 [254x254]	1/10x10 [254x254]	1/10x10 [254x254]
Drive Type	Belt (Adjustable)	Belt (Adjustable)	Belt (Adjustable)	Belt (Adjustable)
No. Speeds	Single	Single	Single	Single
No. Motors	1	1	1	1
Motor HP	1/2	1/2	1/2	3/4
Motor RPM	1725	1725	1725	1725
Motor Frame Size	48	48	48	56
Filter—Type	Disposable	Disposable	Disposable	Disposable
Furnished	Yes	Yes	Yes	Yes
(NO.) Size Recommended in. [mm x mm x mm]	(1)1x16x25 [25x406x635]	(1)1x16x25 [25x406x635]	(1)1x16x25 [25x406x635]	(1)1x16x25 [25x406x635]
	(1)1x16x25 [25x406x635]	(1)1x16x25 [25x406x635]	(1)1x16x25 [25x406x635]	(1)1x16x25 [25x406x635]
Refrigerant Charge Oz. [g]	68 [1928]	68 [1928]	68 [1928]	68 [1928]
Weights				
Net Weight lbs. [kg]	549 [249]	554 [251]	559 [254]	550 [249]
Ship Weight lbs. [kg]	556 [252]	561 [254]	566 [257]	557 [253]

See Page 48 for Notes.

[] Designates Metric Conversions

NOM. SIZES 3-5 TONS [10.6-17.6 kW]

Model RKNN- Series	A048DM10	A048DM13	A048JK08	A048JK10
Cooling Performance¹				CONTINUED →
Gross Cooling Capacity Btu [kW]	48,000 [14.06]	48,000 [14.06]	48,000 [14.06]	48,000 [14.06]
EER/SEER ²	11.5/13	11.5/13	11.5/13	11.5/13
Nominal CFM/AHRI Rated CFM [L/s]	1600/1500 [755/708]	1600/1500 [755/708]	1600/1500 [755/708]	1600/1500 [755/708]
AHRI Net Cooling Capacity Btu [kW]	46,000 [13.48]	46,000 [13.48]	46,000 [13.48]	46,000 [13.48]
Net Sensible Capacity Btu [kW]	34,000 [9.96]	34,000 [9.96]	34,000 [9.96]	34,000 [9.96]
Net Latent Capacity Btu [kW]	12,000 [3.52]	12,000 [3.52]	12,000 [3.52]	12,000 [3.52]
Net System Power kW	3.93	3.93	3.93	3.93
Heating Performance (Gas)³				
Heating Input Btu [kW]	100,000 [29.3]	135,000 [39.55]	80,000 [23.44]	100,000 [29.3]
Heating Output Btu [kW]	81,000 [23.73]	109,350 [32.04]	64,000 [18.76]	80,000 [23.44]
Temperature Rise Range °F [°C]	40-70 [22.2-38.9]	50-80 [27.8-44.4]	30-60 [16.7-33.3]	40-70 [22.2-38.9]
AFUE %	80	80	80	80
Steady State Efficiency (%)	81	81	80	80
No. Burners	5	6	4	5
No. Stages	1	1	1	1
Gas Connection Pipe Size in. [mm]	0.5 [12.7]	0.5 [12.7]	0.5 [12.7]	0.5 [12.7]
Compressor				
No./Type	1/Scroll	1/Scroll	1/Scroll	1/Scroll
Outdoor Sound Rating (dB)⁴	78	78	78	78
Outdoor Coil—Fin Type	Louvered	Louvered	Louvered	Louvered
Tube Type	MicroChannel	MicroChannel	MicroChannel	MicroChannel
MicroChannel Depth in. [mm]	0.7 [18]	0.7 [18]	0.7 [18]	0.7 [18]
Face Area sq. ft. [sq. m]	16.4 [1.52]	16.4 [1.52]	16.4 [1.52]	16.4 [1.52]
Rows / FPI [FPcm]	1 / 23 [9]	1 / 23 [9]	1 / 23 [9]	1 / 23 [9]
Indoor Coil—Fin Type	Louvered	Louvered	Louvered	Louvered
Tube Type	MicroChannel	MicroChannel	MicroChannel	MicroChannel
MicroChannel Depth in. [mm]	1.3 [32]	1.3 [32]	1.3 [32]	1.3 [32]
Face Area sq. ft. [sq. m]	4.8 [0.45]	4.8 [0.45]	4.8 [0.45]	4.8 [0.45]
Rows / FPI [FPcm]	1 / 20 [8]	1 / 20 [8]	1 / 20 [8]	1 / 20 [8]
Refrigerant Control	TX Valves	TX Valves	TX Valves	TX Valves
Drain Connection No./Size in. [mm]	1/0.75 [19.05]	1/0.75 [19.05]	1/0.75 [19.05]	1/0.75 [19.05]
Outdoor Fan—Type	Propeller	Propeller	Propeller	Propeller
No. Used/Diameter in. [mm]	1/24 [609.6]	1/24 [609.6]	1/24 [609.6]	1/24 [609.6]
Drive Type/No. Speeds	Direct/1	Direct/1	Direct/1	Direct/1
CFM [L/s]	3680 [1737]	3680 [1737]	3680 [1737]	3680 [1737]
No. Motors/HP	1 at 1/3 HP	1 at 1/3 HP	1 at 1/3 HP	1 at 1/3 HP
Motor RPM	1075	1075	1075	1075
Indoor Fan—Type	FC Centrifugal	FC Centrifugal	FC Centrifugal	FC Centrifugal
No. Used/Diameter in. [mm]	1/10x10 [254x254]	1/10x10 [254x254]	1/10x10 [254x254]	1/10x10 [254x254]
Drive Type	Belt (Adjustable)	Belt (Adjustable)	Direct	Direct
No. Speeds	Single	Single	Multiple	Multiple
No. Motors	1	1	1	1
Motor HP	3/4	3/4	1/2	1/2
Motor RPM	1725	1725	1075	1075
Motor Frame Size	56	56	48	48
Filter—Type	Disposable	Disposable	Disposable	Disposable
Furnished	Yes	Yes	Yes	Yes
(NO.) Size Recommended in. [mm x mm x mm]	(1)1x16x25 [25x406x635] (1)1x16x25 [25x406x635]	(1)1x16x25 [25x406x635] (1)1x16x25 [25x406x635]	(1)1x16x25 [25x406x635] (1)1x16x25 [25x406x635]	(1)1x16x25 [25x406x635] (1)1x16x25 [25x406x635]
Refrigerant Charge Oz. [g]	68 [1928]	68 [1928]	68 [1928]	68 [1928]
Weights				
Net Weight lbs. [kg]	555 [252]	560 [254]	531 [241]	536 [243]
Ship Weight lbs. [kg]	562 [255]	567 [257]	538 [244]	543 [246]

See Page 48 for Notes.

[] Designates Metric Conversions

NOM. SIZES 3-5 TONS [10.6-17.6 kW]

Model RKNN- Series	A048JK13	A048YL13	A048YM13	A060CK10
Cooling Performance¹				CONTINUED →
Gross Cooling Capacity Btu [kW]	48,000 [14.06]	48,000 [14.06]	48,000 [14.06]	60,000 [17.58]
EER/SEER ²	11.5/13	11.5/13	11.5/13	11.00/13
Nominal CFM/AHRI Rated CFM [L/s]	1600/1500 [755/708]	1600/1500 [755/708]	1600/1500 [755/708]	2000/1850 [944/873]
AHRI Net Cooling Capacity Btu [kW]	46,000 [13.48]	46,000 [13.48]	46,000 [13.48]	58,000 [17.00]
Net Sensible Capacity Btu [kW]	34,000 [9.96]	34,000 [9.96]	34,000 [9.96]	41,500 [12.16]
Net Latent Capacity Btu [kW]	12,000 [3.52]	12,000 [3.52]	12,000 [3.52]	16,500 [4.84]
Net System Power kW	3.93	3.93	3.93	4.9
Heating Performance (Gas)³				
Heating Input Btu [kW]	135,000 [39.55]	135,000 [39.55]	135,000 [39.55]	100,000 [29.3]
Heating Output Btu [kW]	106,000 [31.06]	109,400 [32.05]	109,400 [32.05]	81,000 [23.73]
Temperature Rise Range °F [°C]	50-80 [27.8-44.4]	50-80 [27.8-44.4]	50-80 [27.8-44.4]	25-55 [13.9-30.6]
AFUE %	80	80	80	80
Steady State Efficiency (%)	80	81	81	81
No. Burners	6	6	6	5
No. Stages	1	1	1	1
Gas Connection Pipe Size in. [mm]	0.5 [12.7]	0.5 [12.7]	0.5 [12.7]	0.5 [12.7]
Compressor				
No./Type	1/Scroll	1/Scroll	1/Scroll	1/Scroll
Outdoor Sound Rating (dB)⁴	78	78	78	83
Outdoor Coil—Fin Type	Louvered	Louvered	Louvered	Louvered
Tube Type	MicroChannel	MicroChannel	MicroChannel	MicroChannel
MicroChannel Depth in. [mm]	0.7 [18]	0.7 [18]	0.7 [18]	0.7 [18]
Face Area sq. ft. [sq. m]	16.4 [1.52]	16.4 [1.52]	16.4 [1.52]	16.4 [1.52]
Rows / FPI [FPcm]	1 / 23 [9]	1 / 23 [9]	1 / 23 [9]	1 / 23 [9]
Indoor Coil—Fin Type	Louvered	Louvered	Louvered	Louvered
Tube Type	MicroChannel	MicroChannel	MicroChannel	MicroChannel
MicroChannel Depth in. [mm]	1.3 [32]	1.3 [32]	1.3 [32]	1.3 [32]
Face Area sq. ft. [sq. m]	4.8 [0.45]	4.8 [0.45]	4.8 [0.45]	4.8 [0.45]
Rows / FPI [FPcm]	1 / 20 [8]	1 / 20 [8]	1 / 20 [8]	1 / 20 [8]
Refrigerant Control	TX Valves	TX Valves	TX Valves	TX Valves
Drain Connection No./Size in. [mm]	1/0.75 [19.05]	1/0.75 [19.05]	1/0.75 [19.05]	1/0.75 [19.05]
Outdoor Fan—Type	Propeller	Propeller	Propeller	Propeller
No. Used/Diameter in. [mm]	1/24 [609.6]	1/24 [609.6]	1/24 [609.6]	1/24 [609.6]
Drive Type/No. Speeds	Direct/1	Direct/1	Direct/1	Direct/1
CFM [L/s]	3680 [1737]	3680 [1737]	3680 [1737]	3930 [1855]
No. Motors/HP	1 at 1/3 HP	1 at 1/3 HP	1 at 1/3 HP	1 at 1/3 HP
Motor RPM	1075	1075	1075	1075
Indoor Fan—Type	FC Centrifugal	FC Centrifugal	FC Centrifugal	FC Centrifugal
No. Used/Diameter in. [mm]	1/10x10 [254x254]	1/10x10 [254x254]	1/10x10 [254x254]	1/10x10 [254x254]
Drive Type	Direct	Belt (Adjustable)	Belt (Adjustable)	Direct
No. Speeds	Multiple	Single	Single	Multiple
No. Motors	1	1	1	1
Motor HP	1/2	3/4	3/4	3/4
Motor RPM	1075	1725	1725	1075
Motor Frame Size	48	56	56	48
Filter—Type	Disposable	Disposable	Disposable	Disposable
Furnished	Yes	Yes	Yes	Yes
(NO.) Size Recommended in. [mm x mm x mm]	(1)1x16x25 [25x406x635]	(1)1x16x25 [25x406x635]	(1)1x16x25 [25x406x635]	(1)1x16x25 [25x406x635]
	(1)1x16x25 [25x406x635]	(1)1x16x25 [25x406x635]	(1)1x16x25 [25x406x635]	(1)1x16x25 [25x406x635]
Refrigerant Charge Oz. [g]	68 [1928]	68 [1928]	68 [1928]	63 [1786]
Weights				
Net Weight lbs. [kg]	541 [245]	555 [252]	560 [254]	550 [249]
Ship Weight lbs. [kg]	548 [249]	562 [255]	567 [257]	557 [253]

See Page 48 for Notes.

[] Designates Metric Conversions

NOM. SIZES 3-5 TONS [10.6-17.6 kW]

Model RKNN- Series	A060CK13	A060CL10	A060CL13	A060CM10
Cooling Performance¹				CONTINUED →
Gross Cooling Capacity Btu [kW]	60,000 [17.58]	60,000 [17.58]	60,000 [17.58]	60,000 [17.58]
EER/SEER ²	11.00/13	11.00/13	11.00/13	11.00/13
Nominal CFM/AHRI Rated CFM [L/s]	2000/1850 [944/873]	2000/1850 [944/873]	2000/1850 [944/873]	2000/1850 [944/873]
AHRI Net Cooling Capacity Btu [kW]	58,000 [17.00]	58,000 [17.00]	58,000 [17.00]	58,000 [17.00]
Net Sensible Capacity Btu [kW]	41,500 [12.16]	41,500 [12.16]	41,500 [12.16]	41,500 [12.16]
Net Latent Capacity Btu [kW]	16,500 [4.84]	16,500 [4.84]	16,500 [4.84]	16,500 [4.84]
Net System Power kW	4.9	4.9	4.9	4.9
Heating Performance (Gas)³				
Heating Input Btu [kW]	135,000 [39.55]	100,000 [29.3]	135,000 [39.55]	100,000 [29.3]
Heating Output Btu [kW]	109,400 [32.05]	81,000 [23.73]	109,400 [32.05]	81,000 [23.73]
Temperature Rise Range °F [°C]	40-70 [22.2-38.9]	25-55 [13.9-30.6]	40-70 [22.2-38.9]	25-55 [13.9-30.6]
AFUE %	80	80	80	80
Steady State Efficiency (%)	81	81	81	81
No. Burners	6	5	6	5
No. Stages	1	1	1	1
Gas Connection Pipe Size in. [mm]	0.5 [12.7]	0.5 [12.7]	0.5 [12.7]	0.5 [12.7]
Compressor				
No./Type	1/Scroll	1/Scroll	1/Scroll	1/Scroll
Outdoor Sound Rating (dB)⁴	83	83	83	83
Outdoor Coil—Fin Type	Louvered	Louvered	Louvered	Louvered
Tube Type	MicroChannel	MicroChannel	MicroChannel	MicroChannel
MicroChannel Depth in. [mm]	0.7 [18]	0.7 [18]	0.7 [18]	0.7 [18]
Face Area sq. ft. [sq. m]	16.4 [1.52]	16.4 [1.52]	16.4 [1.52]	16.4 [1.52]
Rows / FPI [FPcm]	1 / 23 [9]	1 / 23 [9]	1 / 23 [9]	1 / 23 [9]
Indoor Coil—Fin Type	Louvered	Louvered	Louvered	Louvered
Tube Type	MicroChannel	MicroChannel	MicroChannel	MicroChannel
MicroChannel Depth in. [mm]	1.3 [32]	1.3 [32]	1.3 [32]	1.3 [32]
Face Area sq. ft. [sq. m]	4.8 [0.45]	4.8 [0.45]	4.8 [0.45]	4.8 [0.45]
Rows / FPI [FPcm]	1 / 20 [8]	1 / 20 [8]	1 / 20 [8]	1 / 20 [8]
Refrigerant Control	TX Valves	TX Valves	TX Valves	TX Valves
Drain Connection No./Size in. [mm]	1/0.75 [19.05]	1/0.75 [19.05]	1/0.75 [19.05]	1/0.75 [19.05]
Outdoor Fan—Type	Propeller	Propeller	Propeller	Propeller
No. Used/Diameter in. [mm]	1/24 [609.6]	1/24 [609.6]	1/24 [609.6]	1/24 [609.6]
Drive Type/No. Speeds	Direct/1	Direct/1	Direct/1	Direct/1
CFM [L/s]	3930 [1855]	3930 [1855]	3930 [1855]	3930 [1855]
No. Motors/HP	1 at 1/3 HP	1 at 1/3 HP	1 at 1/3 HP	1 at 1/3 HP
Motor RPM	1075	1075	1075	1075
Indoor Fan—Type	FC Centrifugal	FC Centrifugal	FC Centrifugal	FC Centrifugal
No. Used/Diameter in. [mm]	1/10x10 [254x254]	1/11x10 [279x254]	1/11x10 [279x254]	1/11x10 [279x254]
Drive Type	Direct	Belt (Adjustable)	Belt (Adjustable)	Belt (Adjustable)
No. Speeds	Multiple	Single	Single	Single
No. Motors	1	1	1	1
Motor HP	3/4	3/4	3/4	1
Motor RPM	1075	1725	1725	1725
Motor Frame Size	48	56	56	56
Filter—Type	Disposable	Disposable	Disposable	Disposable
Furnished	Yes	Yes	Yes	Yes
(NO.) Size Recommended in. [mm x mm x mm]	(1)1x16x25 [25x406x635] (1)1x16x25 [25x406x635]	(1)1x16x25 [25x406x635] (1)1x16x25 [25x406x635]	(1)1x16x25 [25x406x635] (1)1x16x25 [25x406x635]	(1)1x16x25 [25x406x635] (1)1x16x25 [25x406x635]
Refrigerant Charge Oz. [g]	63 [1786]	63 [1786]	63 [1786]	63 [1786]
Weights				
Net Weight lbs. [kg]	555 [252]	562 [255]	567 [257]	567 [257]
Ship Weight lbs. [kg]	562 [255]	569 [258]	574 [260]	574 [260]

See Page 48 for Notes.

[] Designates Metric Conversions

NOM. SIZES 3-5 TONS [10.6-17.6 kW]

Model RKNN- Series	A060CM13	A060DK10	A060DK13	A060DL10
Cooling Performance¹				CONTINUED →
Gross Cooling Capacity Btu [kW]	60,000 [17.58]	60,000 [17.58]	60,000 [17.58]	60,000 [17.58]
EER/SEER ²	11.00/13	11.00/13	11.00/13	11.00/13
Nominal CFM/AHRI Rated CFM [L/s]	2000/1850 [944/873]	2000/1850 [944/873]	2000/1850 [944/873]	2000/1850 [944/873]
AHRI Net Cooling Capacity Btu [kW]	58,000 [17.00]	58,000 [17.00]	58,000 [17.00]	58,000 [17.00]
Net Sensible Capacity Btu [kW]	41,500 [12.16]	41,500 [12.16]	41,500 [12.16]	41,500 [12.16]
Net Latent Capacity Btu [kW]	16,500 [4.84]	16,500 [4.84]	16,500 [4.84]	16,500 [4.84]
Net System Power kW	4.9	4.9	4.9	4.9
Heating Performance (Gas)³				
Heating Input Btu [kW]	135,000 [39.55]	100,000 [29.3]	135,000 [39.55]	100,000 [29.3]
Heating Output Btu [kW]	109,400 [32.05]	81,000 [23.73]	109,400 [32.05]	81,000 [23.73]
Temperature Rise Range °F [°C]	40-70 [22.2-38.9]	25-55 [13.9-30.6]	40-70 [22.2-38.9]	25-55 [13.9-30.6]
AFUE %	80	80	80	80
Steady State Efficiency (%)	81	81	81	81
No. Burners	6	5	6	5
No. Stages	1	1	1	1
Gas Connection Pipe Size in. [mm]	0.5 [12.7]	0.5 [12.7]	0.5 [12.7]	0.5 [12.7]
Compressor				
No./Type	1/Scroll	1/Scroll	1/Scroll	1/Scroll
Outdoor Sound Rating (dB)⁴	83	83	83	83
Outdoor Coil—Fin Type	Louvered	Louvered	Louvered	Louvered
Tube Type	MicroChannel	MicroChannel	MicroChannel	MicroChannel
MicroChannel Depth in. [mm]	0.7 [18]	0.7 [18]	0.7 [18]	0.7 [18]
Face Area sq. ft. [sq. m]	16.4 [1.52]	16.4 [1.52]	16.4 [1.52]	16.4 [1.52]
Rows / FPI [FPcm]	1 / 23 [9]	1 / 23 [9]	1 / 23 [9]	1 / 23 [9]
Indoor Coil—Fin Type	Louvered	Louvered	Louvered	Louvered
Tube Type	MicroChannel	MicroChannel	MicroChannel	MicroChannel
MicroChannel Depth in. [mm]	1.3 [32]	1.3 [32]	1.3 [32]	1.3 [32]
Face Area sq. ft. [sq. m]	4.8 [0.45]	4.8 [0.45]	4.8 [0.45]	4.8 [0.45]
Rows / FPI [FPcm]	1 / 20 [8]	1 / 20 [8]	1 / 20 [8]	1 / 20 [8]
Refrigerant Control	TX Valves	TX Valves	TX Valves	TX Valves
Drain Connection No./Size in. [mm]	1/0.75 [19.05]	1/0.75 [19.05]	1/0.75 [19.05]	1/0.75 [19.05]
Outdoor Fan—Type	Propeller	Propeller	Propeller	Propeller
No. Used/Diameter in. [mm]	1/24 [609.6]	1/24 [609.6]	1/24 [609.6]	1/24 [609.6]
Drive Type/No. Speeds	Direct/1	Direct/1	Direct/1	Direct/1
CFM [L/s]	3930 [1855]	3930 [1855]	3930 [1855]	3930 [1855]
No. Motors/HP	1 at 1/3 HP	1 at 1/3 HP	1 at 1/3 HP	1 at 1/3 HP
Motor RPM	1075	1075	1075	1075
Indoor Fan—Type	FC Centrifugal	FC Centrifugal	FC Centrifugal	FC Centrifugal
No. Used/Diameter in. [mm]	1/11x10 [279x254]	1/10x10 [254x254]	1/10x10 [254x254]	1/11x10 [279x254]
Drive Type	Belt (Adjustable)	Direct	Direct	Belt (Adjustable)
No. Speeds	Single	Multiple	Multiple	Single
No. Motors	1	1	1	1
Motor HP	1	3/4	3/4	3/4
Motor RPM	1725	1075	1075	1725
Motor Frame Size	56	48	48	56
Filter—Type	Disposable	Disposable	Disposable	Disposable
Furnished	Yes	Yes	Yes	Yes
(NO.) Size Recommended in. [mm x mm x mm]	(1)1x16x25 [25x406x635]	(1)1x16x25 [25x406x635]	(1)1x16x25 [25x406x635]	(1)1x16x25 [25x406x635]
	(1)1x16x25 [25x406x635]	(1)1x16x25 [25x406x635]	(1)1x16x25 [25x406x635]	(1)1x16x25 [25x406x635]
Refrigerant Charge Oz. [g]	63 [1786]	63 [1786]	63 [1786]	63 [1786]
Weights				
Net Weight lbs. [kg]	572 [259]	550 [249]	555 [252]	562 [255]
Ship Weight lbs. [kg]	579 [263]	557 [253]	562 [255]	569 [258]

See Page 48 for Notes.

[] Designates Metric Conversions



NOM. SIZES 3-5 TONS [10.6-17.6 kW]

Model RKNN- Series	A060DL13	A060DM10	A060DM13	A060JK10
Cooling Performance¹				CONTINUED →
Gross Cooling Capacity Btu [kW]	60,000 [17.58]	60,000 [17.58]	60,000 [17.58]	60,000 [17.58]
EER/SEER ²	11.00/13	11.00/13	11.00/13	11.00/13
Nominal CFM/AHRI Rated CFM [L/s]	2000/1850 [944/873]	2000/1850 [944/873]	2000/1850 [944/873]	2000/1850 [944/873]
AHRI Net Cooling Capacity Btu [kW]	58,000 [17.00]	58,000 [17.00]	58,000 [17.00]	58,000 [17.00]
Net Sensible Capacity Btu [kW]	41,500 [12.16]	41,500 [12.16]	41,500 [12.16]	41,500 [12.16]
Net Latent Capacity Btu [kW]	16,500 [4.84]	16,500 [4.84]	16,500 [4.84]	16,500 [4.84]
Net System Power kW	4.9	4.9	4.9	4.9
Heating Performance (Gas)³				
Heating Input Btu [kW]	135,000 [39.55]	100,000 [29.3]	135,000 [39.55]	100,000 [29.3]
Heating Output Btu [kW]	109,400 [32.05]	81,000 [23.73]	109,400 [32.05]	80,000 [23.44]
Temperature Rise Range °F [°C]	40-70 [22.2-38.9]	25-55 [13.9-30.6]	40-70 [22.2-38.9]	25-55 [13.9-30.6]
AFUE %	80	80	80	80
Steady State Efficiency (%)	81	81	81	80
No. Burners	6	5	6	5
No. Stages	1	1	1	1
Gas Connection Pipe Size in. [mm]	0.5 [12.7]	0.5 [12.7]	0.5 [12.7]	0.5 [12.7]
Compressor				
No./Type	1/Scroll	1/Scroll	1/Scroll	1/Scroll
Outdoor Sound Rating (dB)⁴	83	83	83	83
Outdoor Coil—Fin Type	Louvered	Louvered	Louvered	Louvered
Tube Type	MicroChannel	MicroChannel	MicroChannel	MicroChannel
MicroChannel Depth in. [mm]	0.7 [18]	0.7 [18]	0.7 [18]	0.7 [18]
Face Area sq. ft. [sq. m]	16.4 [1.52]	16.4 [1.52]	16.4 [1.52]	16.4 [1.52]
Rows / FPI [FPcm]	1 / 23 [9]	1 / 23 [9]	1 / 23 [9]	1 / 23 [9]
Indoor Coil—Fin Type	Louvered	Louvered	Louvered	Louvered
Tube Type	MicroChannel	MicroChannel	MicroChannel	MicroChannel
MicroChannel Depth in. [mm]	1.3 [32]	1.3 [32]	1.3 [32]	1.3 [32]
Face Area sq. ft. [sq. m]	4.8 [0.45]	4.8 [0.45]	4.8 [0.45]	4.8 [0.45]
Rows / FPI [FPcm]	1 / 20 [8]	1 / 20 [8]	1 / 20 [8]	1 / 20 [8]
Refrigerant Control	TX Valves	TX Valves	TX Valves	TX Valves
Drain Connection No./Size in. [mm]	1/0.75 [19.05]	1/0.75 [19.05]	1/0.75 [19.05]	1/0.75 [19.05]
Outdoor Fan—Type	Propeller	Propeller	Propeller	Propeller
No. Used/Diameter in. [mm]	1/24 [609.6]	1/24 [609.6]	1/24 [609.6]	1/24 [609.6]
Drive Type/No. Speeds	Direct/1	Direct/1	Direct/1	Direct/1
CFM [L/s]	3930 [1855]	3930 [1855]	3930 [1855]	3930 [1855]
No. Motors/HP	1 at 1/3 HP	1 at 1/3 HP	1 at 1/3 HP	1 at 1/3 HP
Motor RPM	1075	1075	1075	1075
Indoor Fan—Type	FC Centrifugal	FC Centrifugal	FC Centrifugal	FC Centrifugal
No. Used/Diameter in. [mm]	1/11x10 [279x254]	1/11x10 [279x254]	1/11x10 [279x254]	1/10x10 [254x254]
Drive Type	Belt (Adjustable)	Belt (Adjustable)	Belt (Adjustable)	Direct
No. Speeds	Single	Single	Single	Multiple
No. Motors	1	1	1	1
Motor HP	3/4	1	1	3/4
Motor RPM	1725	1725	1725	1075
Motor Frame Size	56	56	56	48
Filter—Type	Disposable	Disposable	Disposable	Disposable
Furnished	Yes	Yes	Yes	Yes
(NO.) Size Recommended in. [mm x mm x mm]	(1)1x16x25 [25x406x635]	(1)1x16x25 [25x406x635]	(1)1x16x25 [25x406x635]	(1)1x16x25 [25x406x635]
	(1)1x16x25 [25x406x635]	(1)1x16x25 [25x406x635]	(1)1x16x25 [25x406x635]	(1)1x16x25 [25x406x635]
Refrigerant Charge Oz. [g]	63 [1786]	63 [1786]	63 [1786]	63 [1786]
Weights				
Net Weight lbs. [kg]	567 [257]	567 [257]	572 [259]	550 [249]
Ship Weight lbs. [kg]	574 [260]	574 [260]	579 [263]	557 [253]

See Page 48 for Notes.

[] Designates Metric Conversions

NOM. SIZES 3-5 TONS [10.6-17.6 kW]

Model RKNN- Series	A060JK13	A060YL13	A060YM13
Cooling Performance¹			
Gross Cooling Capacity Btu [kW]	60,000 [17.58]	60,000 [17.58]	60,000 [17.58]
EER/SEER ²	11.00/13	11.00/13	11.00/13
Nominal CFM/AHRI Rated CFM [L/s]	2000/1850 [944/873]	2000/1850 [944/873]	2000/1850 [944/873]
AHRI Net Cooling Capacity Btu [kW]	58,000 [17.00]	58,000 [17.00]	58,000 [17.00]
Net Sensible Capacity Btu [kW]	41,500 [12.16]	41,500 [12.16]	41,500 [12.16]
Net Latent Capacity Btu [kW]	16,500 [4.84]	16,500 [4.84]	16,500 [4.84]
Net System Power kW	4.9	4.9	4.9
Heating Performance (Gas)³			
Heating Input Btu [kW]	135,000 [39.55]	135,000 [39.55]	135,000 [39.55]
Heating Output Btu [kW]	108,000 [31.65]	109,400 [32.05]	109,400 [32.05]
Temperature Rise Range °F [°C]	40-70 [22.2-38.9]	40-70 [22.2-38.9]	40-70 [22.2-38.9]
AFUE %	80	80	80
Steady State Efficiency (%)	80	81	81
No. Burners	6	6	6
No. Stages	1	1	1
Gas Connection Pipe Size in. [mm]	0.5 [12.7]	0.5 [12.7]	0.5 [12.7]
Compressor			
No./Type	1/Scroll	1/Scroll	1/Scroll
Outdoor Sound Rating (dB)⁴			
	83	83	83
Outdoor Coil—Fin Type			
Tube Type	Louvered	Louvered	Louvered
MicroChannel Depth in. [mm]	MicroChannel	MicroChannel	MicroChannel
Face Area sq. ft. [sq. m]	0.7 [18]	0.7 [18]	0.7 [18]
Rows / FPI [FPcm]	16.4 [1.52]	16.4 [1.52]	16.4 [1.52]
	1 / 23 [9]	1 / 23 [9]	1 / 23 [9]
Indoor Coil—Fin Type			
Tube Type	Louvered	Louvered	Louvered
MicroChannel Depth in. [mm]	MicroChannel	MicroChannel	MicroChannel
Face Area sq. ft. [sq. m]	1.3 [32]	1.3 [32]	1.3 [32]
Rows / FPI [FPcm]	4.8 [0.45]	4.8 [0.45]	4.8 [0.45]
	1 / 20 [8]	1 / 20 [8]	1 / 20 [8]
Refrigerant Control	TX Valves	TX Valves	TX Valves
Drain Connection No./Size in. [mm]	1/0.75 [19.05]	1/0.75 [19.05]	1/0.75 [19.05]
Outdoor Fan—Type			
No. Used/Diameter in. [mm]	Propeller	Propeller	Propeller
Drive Type/No. Speeds	1/24 [609.6]	1/24 [609.6]	1/24 [609.6]
CFM [L/s]	Direct/1	Direct/1	Direct/1
No. Motors/HP	3930 [1855]	3930 [1855]	3930 [1855]
Motor RPM	1 at 1/3 HP	1 at 1/3 HP	1 at 1/3 HP
	1075	1075	1075
Indoor Fan—Type			
No. Used/Diameter in. [mm]	FC Centrifugal	FC Centrifugal	FC Centrifugal
Drive Type	1/10x10 [254x254]	1/10x10 [254x254]	1/10x10 [254x254]
No. Speeds	Direct	Belt (Adjustable)	Belt (Adjustable)
No. Motors	Multiple	Single	Single
Motor HP	1	1	1
Motor RPM	3/4	3/4	1
Motor Frame Size	1075	1725	1725
	48	56	56
Filter—Type			
Furnished	Disposable	Disposable	Disposable
(NO.) Size Recommended in. [mm x mm x mm]	Yes	Yes	Yes
	(1)1x16x25 [25x406x635]	(1)1x16x25 [25x406x635]	(1)1x16x25 [25x406x635]
	(1)1x16x25 [25x406x635]	(1)1x16x25 [25x406x635]	(1)1x16x25 [25x406x635]
Refrigerant Charge Oz. [g]			
	63 [1786]	63 [1786]	63 [1786]
Weights			
Net Weight lbs. [kg]	555 [252]	555 [252]	560 [254]
Ship Weight lbs. [kg]	562 [255]	562 [255]	567 [257]

See Page 48 for Notes.

[] Designates Metric Conversions

NOM. SIZES 3-5 TONS [10.6-17.6 kW]

Model RKPN- Series	A036CK08	A036CK12	A036CL08	A036CL12
Cooling Performance¹				CONTINUED →
Gross Cooling Capacity Btu [kW]	36,200 [10.61]	36,200 [10.61]	36,200 [10.61]	36,200 [10.61]
EER/SEER ²	11.6/14	11.6/14	11.6/14	11.6/14
Nominal CFM/AHRI Rated CFM [L/s]	1200/1250 [566/590]	1200/1250 [566/590]	1200/1250 [566/590]	1200/1250 [566/590]
AHRI Net Cooling Capacity Btu [kW]	34,600 [10.14]	34,600 [10.14]	34,600 [10.14]	34,600 [10.14]
Net Sensible Capacity Btu [kW]	25,300 [7.41]	25,300 [7.41]	25,300 [7.41]	25,300 [7.41]
Net Latent Capacity Btu [kW]	9,300 [2.72]	9,300 [2.72]	9,300 [2.72]	9,300 [2.72]
Net System Power kW	2.95	2.95	2.95	2.95
Heating Performance (Gas)³				
Heating Input Btu [kW]	80,000 [23.44]	120,000 [35.16]	80,000 [23.44]	120,000 [35.16]
Heating Output Btu [kW]	64,800 [18.99]	97,200 [28.48]	64,800 [18.99]	97,200 [28.48]
Temperature Rise Range °F [°C]	30-60 [16.7-33.3]	50-80 [27.8-44.4]	30-60 [16.7-33.3]	50-80 [27.8-44.4]
AFUE %	80	80	80	80
Steady State Efficiency (%)	81	81	81	81
No. Burners	4	6	4	6
No. Stages	1	1	1	1
Gas Connection Pipe Size in. [mm]	0.5 [12.7]	0.5 [12.7]	0.5 [12.7]	0.5 [12.7]
Compressor				
No./Type	1/Scroll	1/Scroll	1/Scroll	1/Scroll
Outdoor Sound Rating (dB)⁴	78	78	78	78
Outdoor Coil—Fin Type	Louvered	Louvered	Louvered	Louvered
Tube Type	MicroChannel	MicroChannel	MicroChannel	MicroChannel
MicroChannel Depth in. [mm]	0.7 [18]	0.7 [18]	0.7 [18]	0.7 [18]
Face Area sq. ft. [sq. m]	13.9 [1.29]	13.9 [1.29]	13.9 [1.29]	13.9 [1.29]
Rows / FPI [FPcm]	1 / 23 [9]	1 / 23 [9]	1 / 23 [9]	1 / 23 [9]
Indoor Coil—Fin Type	Louvered	Louvered	Louvered	Louvered
Tube Type	MicroChannel	MicroChannel	MicroChannel	MicroChannel
MicroChannel Depth in. [mm]	1 [25]	1 [25]	1 [25]	1 [25]
Face Area sq. ft. [sq. m]	4.8 [0.45]	4.8 [0.45]	4.8 [0.45]	4.8 [0.45]
Rows / FPI [FPcm]	1 / 20 [8]	1 / 20 [8]	1 / 20 [8]	1 / 20 [8]
Refrigerant Control	TX Valves	TX Valves	TX Valves	TX Valves
Drain Connection No./Size in. [mm]	1/0.75 [19.05]	1/0.75 [19.05]	1/0.75 [19.05]	1/0.75 [19.05]
Outdoor Fan—Type	Propeller	Propeller	Propeller	Propeller
No. Used/Diameter in. [mm]	1/24 [609.6]	1/24 [609.6]	1/24 [609.6]	1/24 [609.6]
Drive Type/No. Speeds	Direct/1	Direct/1	Direct/1	Direct/1
CFM [L/s]	3680 [1737]	3680 [1737]	3680 [1737]	3680 [1737]
No. Motors/HP	1 at 1/3 HP	1 at 1/3 HP	1 at 1/3 HP	1 at 1/3 HP
Motor RPM	1075	1075	1075	1075
Indoor Fan—Type	FC Centrifugal	FC Centrifugal	FC Centrifugal	FC Centrifugal
No. Used/Diameter in. [mm]	1/10x10 [254x254]	1/10x10 [254x254]	1/10x10 [254x254]	1/10x10 [254x254]
Drive Type	Direct	Direct	Belt (Adjustable)	Belt (Adjustable)
No. Speeds	Multiple	Multiple	Single	Single
No. Motors	1	1	1	1
Motor HP	1/2	1/2	1/2	1/2
Motor RPM	1075	1075	1725	1725
Motor Frame Size	48	48	48	48
Filter—Type	Disposable	Disposable	Disposable	Disposable
Furnished	Yes	Yes	Yes	Yes
(NO.) Size Recommended in. [mm x mm x mm]	(1)1x16x25 [25x406x635] (1)1x16x25 [25x406x635]	(1)1x16x25 [25x406x635] (1)1x16x25 [25x406x635]	(1)1x16x25 [25x406x635] (1)1x16x25 [25x406x635]	(1)1x16x25 [25x406x635] (1)1x16x25 [25x406x635]
Refrigerant Charge Oz. [g]	54 [1531]	54 [1531]	54 [1531]	54 [1531]
Weights				
Net Weight lbs. [kg]	507 [230]	517 [235]	525 [238]	517 [235]
Ship Weight lbs. [kg]	514 [233]	525 [238]	532 [241]	525 [238]

See Page 48 for Notes.

[] Designates Metric Conversions

NOM. SIZES 3-5 TONS [10.6-17.6 kW]

Model RKPN- Series	A036CM08	A036CM12	A036DK08	A036DK12
Cooling Performance¹				CONTINUED →
Gross Cooling Capacity Btu [kW]	36,200 [10.61]	36,200 [10.61]	36,200 [10.61]	36,200 [10.61]
EER/SEER ²	11.6/14	11.6/14	11.6/14	11.6/14
Nominal CFM/AHRI Rated CFM [L/s]	1200/1250 [566/590]	1200/1250 [566/590]	1200/1250 [566/590]	1200/1250 [566/590]
AHRI Net Cooling Capacity Btu [kW]	34,600 [10.14]	34,600 [10.14]	34,600 [10.14]	34,600 [10.14]
Net Sensible Capacity Btu [kW]	25,300 [7.41]	25,300 [7.41]	25,300 [7.41]	25,300 [7.41]
Net Latent Capacity Btu [kW]	9,300 [2.72]	9,300 [2.72]	9,300 [2.72]	9,300 [2.72]
Net System Power kW	2.95	2.95	2.95	2.95
Heating Performance (Gas)³				
Heating Input Btu [kW]	80,000 [23.44]	120,000 [35.16]	80,000 [23.44]	120,000 [35.16]
Heating Output Btu [kW]	64,800 [18.99]	97,200 [28.48]	64,800 [18.99]	97,200 [28.48]
Temperature Rise Range °F [°C]	30-60 [16.7-33.3]	50-80 [27.8-44.4]	30-60 [16.7-33.3]	50-80 [27.8-44.4]
AFUE %	80	80	80	80
Steady State Efficiency (%)	81	81	81	81
No. Burners	4	6	4	6
No. Stages	1	1	1	1
Gas Connection Pipe Size in. [mm]	0.5 [12.7]	0.5 [12.7]	0.5 [12.7]	0.5 [12.7]
Compressor				
No./Type	1/Scroll	1/Scroll	1/Scroll	1/Scroll
Outdoor Sound Rating (dB)⁴	78	78	78	78
Outdoor Coil—Fin Type	Louvered	Louvered	Louvered	Louvered
Tube Type	MicroChannel	MicroChannel	MicroChannel	MicroChannel
MicroChannel Depth in. [mm]	0.7 [18]	0.7 [18]	0.7 [18]	0.7 [18]
Face Area sq. ft. [sq. m]	13.9 [1.29]	13.9 [1.29]	13.9 [1.29]	13.9 [1.29]
Rows / FPI [FPcm]	1 / 23 [9]	1 / 23 [9]	1 / 23 [9]	1 / 23 [9]
Indoor Coil—Fin Type	Louvered	Louvered	Louvered	Louvered
Tube Type	MicroChannel	MicroChannel	MicroChannel	MicroChannel
MicroChannel Depth in. [mm]	1 [25]	1 [25]	1 [25]	1 [25]
Face Area sq. ft. [sq. m]	4.8 [0.45]	4.8 [0.45]	4.8 [0.45]	4.8 [0.45]
Rows / FPI [FPcm]	1 / 20 [8]	1 / 20 [8]	1 / 20 [8]	1 / 20 [8]
Refrigerant Control	TX Valves	TX Valves	TX Valves	TX Valves
Drain Connection No./Size in. [mm]	1/0.75 [19.05]	1/0.75 [19.05]	1/0.75 [19.05]	1/0.75 [19.05]
Outdoor Fan—Type	Propeller	Propeller	Propeller	Propeller
No. Used/Diameter in. [mm]	1/24 [609.6]	1/24 [609.6]	1/24 [609.6]	1/24 [609.6]
Drive Type/No. Speeds	Direct/1	Direct/1	Direct/1	Direct/1
CFM [L/s]	3680 [1737]	3680 [1737]	3680 [1737]	3680 [1737]
No. Motors/HP	1 at 1/3 HP	1 at 1/3 HP	1 at 1/3 HP	1 at 1/3 HP
Motor RPM	1075	1075	1075	1075
Indoor Fan—Type	FC Centrifugal	FC Centrifugal	FC Centrifugal	FC Centrifugal
No. Used/Diameter in. [mm]	1/10x10 [254x254]	1/10x10 [254x254]	1/10x10 [254x254]	1/10x10 [254x254]
Drive Type	Belt (Adjustable)	Belt (Adjustable)	Direct	Direct
No. Speeds	Single	Single	Multiple	Multiple
No. Motors	1	1	1	1
Motor HP	1/2	1/2	1/2	1/2
Motor RPM	1725	1725	1075	1075
Motor Frame Size	48	48	48	48
Filter—Type	Disposable	Disposable	Disposable	Disposable
Furnished	Yes	Yes	Yes	Yes
(NO.) Size Recommended in. [mm x mm x mm]	(1)1x16x25 [25x406x635]	(1)1x16x25 [25x406x635]	(1)1x16x25 [25x406x635]	(1)1x16x25 [25x406x635]
	(1)1x16x25 [25x406x635]	(1)1x16x25 [25x406x635]	(1)1x16x25 [25x406x635]	(1)1x16x25 [25x406x635]
Refrigerant Charge Oz. [g]	54 [1531]	54 [1531]	54 [1531]	54 [1531]
Weights				
Net Weight lbs. [kg]	525 [238]	517 [235]	507 [230]	517 [235]
Ship Weight lbs. [kg]	532 [241]	525 [238]	514 [233]	525 [238]

See Page 48 for Notes.

[] Designates Metric Conversions



NOM. SIZES 3-5 TONS [10.6-17.6 kW]

Model RKPN- Series	A036DL08	A036DL12	A036DM08	A036DM12
Cooling Performance¹				CONTINUED →
Gross Cooling Capacity Btu [kW]	36,200 [10.61]	36,200 [10.61]	36,200 [10.61]	36,200 [10.61]
EER/SEER ²	11.6/14	11.6/14	11.6/14	11.6/14
Nominal CFM/AHRI Rated CFM [L/s]	1200/1250 [566/590]	1200/1250 [566/590]	1200/1250 [566/590]	1200/1250 [566/590]
AHRI Net Cooling Capacity Btu [kW]	34,600 [10.14]	34,600 [10.14]	34,600 [10.14]	34,600 [10.14]
Net Sensible Capacity Btu [kW]	25,300 [7.41]	25,300 [7.41]	25,300 [7.41]	25,300 [7.41]
Net Latent Capacity Btu [kW]	9,300 [2.72]	9,300 [2.72]	9,300 [2.72]	9,300 [2.72]
Net System Power kW	2.95	2.95	2.95	2.95
Heating Performance (Gas)³				
Heating Input Btu [kW]	80,000 [23.44]	120,000 [35.16]	80,000 [23.44]	120,000 [35.16]
Heating Output Btu [kW]	64,800 [18.99]	97,200 [28.48]	64,800 [18.99]	97,200 [28.48]
Temperature Rise Range °F [°C]	30-60 [16.7-33.3]	50-80 [27.8-44.4]	30-60 [16.7-33.3]	50-80 [27.8-44.4]
AFUE %	80	80	80	80
Steady State Efficiency (%)	81	81	81	81
No. Burners	4	6	4	6
No. Stages	1	1	1	1
Gas Connection Pipe Size in. [mm]	0.5 [12.7]	0.5 [12.7]	0.5 [12.7]	0.5 [12.7]
Compressor				
No./Type	1/Scroll	1/Scroll	1/Scroll	1/Scroll
Outdoor Sound Rating (dB)⁴	78	78	78	78
Outdoor Coil—Fin Type	Louvered	Louvered	Louvered	Louvered
Tube Type	MicroChannel	MicroChannel	MicroChannel	MicroChannel
MicroChannel Depth in. [mm]	0.7 [18]	0.7 [18]	0.7 [18]	0.7 [18]
Face Area sq. ft. [sq. m]	13.9 [1.29]	13.9 [1.29]	13.9 [1.29]	13.9 [1.29]
Rows / FPI [FPcm]	1 / 23 [9]	1 / 23 [9]	1 / 23 [9]	1 / 23 [9]
Indoor Coil—Fin Type	Louvered	Louvered	Louvered	Louvered
Tube Type	MicroChannel	MicroChannel	MicroChannel	MicroChannel
MicroChannel Depth in. [mm]	1 [25]	1 [25]	1 [25]	1 [25]
Face Area sq. ft. [sq. m]	4.8 [0.45]	4.8 [0.45]	4.8 [0.45]	4.8 [0.45]
Rows / FPI [FPcm]	1 / 20 [8]	1 / 20 [8]	1 / 20 [8]	1 / 20 [8]
Refrigerant Control	TX Valves	TX Valves	TX Valves	TX Valves
Drain Connection No./Size in. [mm]	1/0.75 [19.05]	1/0.75 [19.05]	1/0.75 [19.05]	1/0.75 [19.05]
Outdoor Fan—Type	Propeller	Propeller	Propeller	Propeller
No. Used/Diameter in. [mm]	1/24 [609.6]	1/24 [609.6]	1/24 [609.6]	1/24 [609.6]
Drive Type/No. Speeds	Direct/1	Direct/1	Direct/1	Direct/1
CFM [L/s]	3680 [1737]	3680 [1737]	3680 [1737]	3680 [1737]
No. Motors/HP	1 at 1/3 HP	1 at 1/3 HP	1 at 1/3 HP	1 at 1/3 HP
Motor RPM	1075	1075	1075	1075
Indoor Fan—Type	FC Centrifugal	FC Centrifugal	FC Centrifugal	FC Centrifugal
No. Used/Diameter in. [mm]	1/10x10 [254x254]	1/10x10 [254x254]	1/10x10 [254x254]	1/10x10 [254x254]
Drive Type	Belt (Adjustable)	Belt (Adjustable)	Belt (Adjustable)	Belt (Adjustable)
No. Speeds	Single	Single	Single	Single
No. Motors	1	1	1	1
Motor HP	1/2	1/2	1/2	1/2
Motor RPM	1725	1725	1725	1725
Motor Frame Size	48	48	48	48
Filter—Type	Disposable	Disposable	Disposable	Disposable
Furnished	Yes	Yes	Yes	Yes
(NO.) Size Recommended in. [mm x mm x mm]	(1)1x16x25 [25x406x635] (1)1x16x25 [25x406x635]	(1)1x16x25 [25x406x635] (1)1x16x25 [25x406x635]	(1)1x16x25 [25x406x635] (1)1x16x25 [25x406x635]	(1)1x16x25 [25x406x635] (1)1x16x25 [25x406x635]
Refrigerant Charge Oz. [g]	54 [1531]	54 [1531]	54 [1531]	54 [1531]
Weights				
Net Weight lbs. [kg]	525 [238]	517 [235]	525 [238]	517 [235]
Ship Weight lbs. [kg]	532 [241]	525 [238]	532 [241]	525 [238]

See Page 48 for Notes.

[] Designates Metric Conversions

NOM. SIZES 3-5 TONS [10.6-17.6 kW]

Model RKPN- Series	A036JK08	A036JK12	A036YL12	A036YM12
Cooling Performance¹				CONTINUED →
Gross Cooling Capacity Btu [kW]	36,200 [10.61]	36,200 [10.61]	36,200 [10.61]	36,200 [10.61]
EER/SEER ²	11.6/14	11.6/14	11.6/14	11.6/14
Nominal CFM/AHRI Rated CFM [L/s]	1200/1250 [566/590]	1200/1250 [566/590]	1200/1250 [566/590]	1200/1250 [566/590]
AHRI Net Cooling Capacity Btu [kW]	34,600 [10.14]	34,600 [10.14]	34,600 [10.14]	34,600 [10.14]
Net Sensible Capacity Btu [kW]	25,300 [7.41]	25,300 [7.41]	25,300 [7.41]	25,300 [7.41]
Net Latent Capacity Btu [kW]	9,300 [2.72]	9,300 [2.72]	9,300 [2.72]	9,300 [2.72]
Net System Power kW	2.95	2.95	2.95	2.95
Heating Performance (Gas)³				
Heating Input Btu [kW]	80,000 [23.44]	120,000 [35.16]	120,000 [35.16]	120,000 [35.16]
Heating Output Btu [kW]	64,000 [18.76]	96,000 [28.13]	97,200 [28.48]	97,200 [28.48]
Temperature Rise Range °F [°C]	30-60 [16.7-33.3]	50-80 [27.8-44.4]	50-80 [27.8-44.4]	50-80 [27.8-44.4]
AFUE %	80	80	80	80
Steady State Efficiency (%)	80	80	81	81
No. Burners	4	6	6	6
No. Stages	1	1	1	1
Gas Connection Pipe Size in. [mm]	0.5 [12.7]	0.5 [12.7]	0.5 [12.7]	0.5 [12.7]
Compressor				
No./Type	1/Scroll	1/Scroll	1/Scroll	1/Scroll
Outdoor Sound Rating (dB)⁴	78	78	78	78
Outdoor Coil—Fin Type	Louvered	Louvered	Louvered	Louvered
Tube Type	MicroChannel	MicroChannel	MicroChannel	MicroChannel
MicroChannel Depth in. [mm]	0.7 [18]	0.7 [18]	0.7 [18]	0.7 [18]
Face Area sq. ft. [sq. m]	13.9 [1.29]	13.9 [1.29]	13.9 [1.29]	13.9 [1.29]
Rows / FPI [FPcm]	1 / 23 [9]	1 / 23 [9]	1 / 23 [9]	1 / 23 [9]
Indoor Coil—Fin Type	Louvered	Louvered	Louvered	Louvered
Tube Type	MicroChannel	MicroChannel	MicroChannel	MicroChannel
MicroChannel Depth in. [mm]	1 [25]	1 [25]	1 [25]	1 [25]
Face Area sq. ft. [sq. m]	4.8 [0.45]	4.8 [0.45]	4.8 [0.45]	4.8 [0.45]
Rows / FPI [FPcm]	1 / 20 [8]	1 / 20 [8]	1 / 20 [8]	1 / 20 [8]
Refrigerant Control	TX Valves	TX Valves	TX Valves	TX Valves
Drain Connection No./Size in. [mm]	1/0.75 [19.05]	1/0.75 [19.05]	1/0.75 [19.05]	1/0.75 [19.05]
Outdoor Fan—Type	Propeller	Propeller	Propeller	Propeller
No. Used/Diameter in. [mm]	1/24 [609.6]	1/24 [609.6]	1/24 [609.6]	1/24 [609.6]
Drive Type/No. Speeds	Direct/1	Direct/1	Direct/1	Direct/1
CFM [L/s]	3680 [1737]	3680 [1737]	3680 [1737]	3680 [1737]
No. Motors/HP	1 at 1/3 HP	1 at 1/3 HP	1 at 1/3 HP	1 at 1/3 HP
Motor RPM	1075	1075	1075	1075
Indoor Fan—Type	FC Centrifugal	FC Centrifugal	FC Centrifugal	FC Centrifugal
No. Used/Diameter in. [mm]	1/10x10 [254x254]	1/10x10 [254x254]	1/10x10 [254x254]	1/10x10 [254x254]
Drive Type	Direct	Direct	Belt (Adjustable)	Belt (Adjustable)
No. Speeds	Multiple	Multiple	Single	Single
No. Motors	1	1	1	1
Motor HP	1/2	1/2	3/4	3/4
Motor RPM	1075	1075	1725	1725
Motor Frame Size	48	48	56	56
Filter—Type	Disposable	Disposable	Disposable	Disposable
Furnished	Yes	Yes	Yes	Yes
(NO.) Size Recommended in. [mm x mm x mm]	(1)1x16x25 [25x406x635] (1)1x16x25 [25x406x635]	(1)1x16x25 [25x406x635] (1)1x16x25 [25x406x635]	(1)1x16x25 [25x406x635] (1)1x16x25 [25x406x635]	(1)1x16x25 [25x406x635] (1)1x16x25 [25x406x635]
Refrigerant Charge Oz. [g]	54 [1531]	54 [1531]	54 [1531]	54 [1531]
Weights				
Net Weight lbs. [kg]	507 [230]	517 [235]	517 [235]	517 [235]
Ship Weight lbs. [kg]	514 [233]	525 [238]	525 [238]	525 [238]

See Page 48 for Notes.

[] Designates Metric Conversions



NOM. SIZES 3-5 TONS [10.6-17.6 kW]

Model RKPN- Series	A048CK08	A048CK10	A048CK13	A048CL08
Cooling Performance¹				CONTINUED →
Gross Cooling Capacity Btu [kW]	48,000 [14.06]	48,000 [14.06]	48,000 [14.06]	48,000 [14.06]
EER/SEER ²	11.6/14	11.6/14	11.6/14	11.6/14
Nominal CFM/AHRI Rated CFM [L/s]	1600/1500 [755/708]	1600/1500 [755/708]	1600/1500 [755/708]	1600/1500 [755/708]
AHRI Net Cooling Capacity Btu [kW]	46,000 [13.48]	46,000 [13.48]	46,000 [13.48]	46,000 [13.48]
Net Sensible Capacity Btu [kW]	34,000 [9.96]	34,000 [9.96]	34,000 [9.96]	34,000 [9.96]
Net Latent Capacity Btu [kW]	12,000 [3.52]	12,000 [3.52]	12,000 [3.52]	12,000 [3.52]
Net System Power kW	3.93	3.93	3.93	3.93
Heating Performance (Gas)³				
Heating Input Btu [kW]	80,000 [23.44]	100,000 [29.3]	135,000 [39.55]	80,000 [23.44]
Heating Output Btu [kW]	64,800 [18.99]	81,000 [23.73]	109,400 [32.05]	64,800 [18.99]
Temperature Rise Range °F [°C]	30-60 [16.7-33.3]	40-70 [22.2-38.9]	50-80 [27.8-44.4]	30-60 [16.7-33.3]
AFUE %	80	80	80	80
Steady State Efficiency (%)	81	81	81	81
No. Burners	4	5	6	4
No. Stages	1	1	1	1
Gas Connection Pipe Size in. [mm]	0.5 [12.7]	0.5 [12.7]	0.5 [12.7]	0.5 [12.7]
Compressor				
No./Type	1/Scroll	1/Scroll	1/Scroll	1/Scroll
Outdoor Sound Rating (dB)⁴	78	78	78	78
Outdoor Coil—Fin Type	Louvered	Louvered	Louvered	Louvered
Tube Type	MicroChannel	MicroChannel	MicroChannel	MicroChannel
MicroChannel Depth in. [mm]	0.7 [18]	0.7 [18]	0.7 [18]	0.7 [18]
Face Area sq. ft. [sq. m]	16.4 [1.52]	16.4 [1.52]	16.4 [1.52]	16.4 [1.52]
Rows / FPI [FPcm]	1 / 23 [9]	1 / 23 [9]	1 / 23 [9]	1 / 23 [9]
Indoor Coil—Fin Type	Louvered	Louvered	Louvered	Louvered
Tube Type	MicroChannel	MicroChannel	MicroChannel	MicroChannel
MicroChannel Depth in. [mm]	1.3 [32]	1.3 [32]	1.3 [32]	1.3 [32]
Face Area sq. ft. [sq. m]	4.8 [0.45]	4.8 [0.45]	4.8 [0.45]	4.8 [0.45]
Rows / FPI [FPcm]	1 / 20 [8]	1 / 20 [8]	1 / 20 [8]	1 / 20 [8]
Refrigerant Control	TX Valves	TX Valves	TX Valves	TX Valves
Drain Connection No./Size in. [mm]	1/0.75 [19.05]	1/0.75 [19.05]	1/0.75 [19.05]	1/0.75 [19.05]
Outdoor Fan—Type	Propeller	Propeller	Propeller	Propeller
No. Used/Diameter in. [mm]	1/24 [609.6]	1/24 [609.6]	1/24 [609.6]	1/24 [609.6]
Drive Type/No. Speeds	Direct/1	Direct/1	Direct/1	Direct/1
CFM [L/s]	3680 [1737]	3680 [1737]	3680 [1737]	3680 [1737]
No. Motors/HP	1 at 1/3 HP	1 at 1/3 HP	1 at 1/3 HP	1 at 1/3 HP
Motor RPM	1075	1075	1075	1075
Indoor Fan—Type	FC Centrifugal	FC Centrifugal	FC Centrifugal	FC Centrifugal
No. Used/Diameter in. [mm]	1/10x10 [254x254]	1/10x10 [254x254]	1/10x10 [254x254]	1/10x10 [254x254]
Drive Type	Direct	Direct	Direct	Belt (Adjustable)
No. Speeds	Multiple	Multiple	Multiple	Single
No. Motors	1	1	1	1
Motor HP	1/2	1/2	1/2	1/2
Motor RPM	1075	1075	1075	1725
Motor Frame Size	48	48	48	48
Filter—Type	Disposable	Disposable	Disposable	Disposable
Furnished	Yes	Yes	Yes	Yes
(NO.) Size Recommended in. [mm x mm x mm]	(1)1x16x25 [25x406x635] (1)1x16x25 [25x406x635]	(1)1x16x25 [25x406x635] (1)1x16x25 [25x406x635]	(1)1x16x25 [25x406x635] (1)1x16x25 [25x406x635]	(1)1x16x25 [25x406x635] (1)1x16x25 [25x406x635]
Refrigerant Charge Oz. [g]	68 [1928]	68 [1928]	68 [1928]	68 [1928]
Weights				
Net Weight lbs. [kg]	531 [241]	536 [243]	541 [245]	549 [249]
Ship Weight lbs. [kg]	538 [244]	543 [246]	548 [249]	556 [252]

See Page 48 for Notes.

[] Designates Metric Conversions

NOM. SIZES 3-5 TONS [10.6-17.6 kW]

Model RKPN- Series	A048CL10	A048CL13	A048CM08	A048CM10
Cooling Performance¹				CONTINUED →
Gross Cooling Capacity Btu [kW]	48,000 [14.06]	48,000 [14.06]	48,000 [14.06]	48,000 [14.06]
EER/SEER ²	11.6/14	11.6/14	11.6/14	11.6/14
Nominal CFM/AHRI Rated CFM [L/s]	1600/1500 [755/708]	1600/1500 [755/708]	1600/1500 [755/708]	1600/1500 [755/708]
AHRI Net Cooling Capacity Btu [kW]	46,000 [13.48]	46,000 [13.48]	46,000 [13.48]	46,000 [13.48]
Net Sensible Capacity Btu [kW]	34,000 [9.96]	34,000 [9.96]	34,000 [9.96]	34,000 [9.96]
Net Latent Capacity Btu [kW]	12,000 [3.52]	12,000 [3.52]	12,000 [3.52]	12,000 [3.52]
Net System Power kW	3.93	3.93	3.93	3.93
Heating Performance (Gas)³				
Heating Input Btu [kW]	100,000 [29.3]	135,000 [39.55]	80,000 [23.44]	100,000 [29.3]
Heating Output Btu [kW]	81,000 [23.73]	109,400 [32.05]	64,800 [18.99]	81,000 [23.73]
Temperature Rise Range °F [°C]	40-70 [22.2-38.9]	50-80 [27.8-44.4]	30-60 [16.7-33.3]	40-70 [22.2-38.9]
AFUE %	80	80	80	80
Steady State Efficiency (%)	81	81	81	81
No. Burners	5	6	4	5
No. Stages	1	1	1	1
Gas Connection Pipe Size in. [mm]	0.5 [12.7]	0.5 [12.7]	0.5 [12.7]	0.5 [12.7]
Compressor				
No./Type	1/Scroll	1/Scroll	1/Scroll	1/Scroll
Outdoor Sound Rating (dB)⁴	78	78	78	78
Outdoor Coil—Fin Type	Louvered	Louvered	Louvered	Louvered
Tube Type	MicroChannel	MicroChannel	MicroChannel	MicroChannel
MicroChannel Depth in. [mm]	0.7 [18]	0.7 [18]	0.7 [18]	0.7 [18]
Face Area sq. ft. [sq. m]	16.4 [1.52]	16.4 [1.52]	16.4 [1.52]	16.4 [1.52]
Rows / FPI [FPcm]	1 / 23 [9]	1 / 23 [9]	1 / 23 [9]	1 / 23 [9]
Indoor Coil—Fin Type	Louvered	Louvered	Louvered	Louvered
Tube Type	MicroChannel	MicroChannel	MicroChannel	MicroChannel
MicroChannel Depth in. [mm]	1.3 [32]	1.3 [32]	1.3 [32]	1.3 [32]
Face Area sq. ft. [sq. m]	4.8 [0.45]	4.8 [0.45]	4.8 [0.45]	4.8 [0.45]
Rows / FPI [FPcm]	1 / 20 [8]	1 / 20 [8]	1 / 20 [8]	1 / 20 [8]
Refrigerant Control	TX Valves	TX Valves	TX Valves	TX Valves
Drain Connection No./Size in. [mm]	1/0.75 [19.05]	1/0.75 [19.05]	1/0.75 [19.05]	1/0.75 [19.05]
Outdoor Fan—Type	Propeller	Propeller	Propeller	Propeller
No. Used/Diameter in. [mm]	1/24 [609.6]	1/24 [609.6]	1/24 [609.6]	1/24 [609.6]
Drive Type/No. Speeds	Direct/1	Direct/1	Direct/1	Direct/1
CFM [L/s]	3680 [1737]	3680 [1737]	3680 [1737]	3680 [1737]
No. Motors/HP	1 at 1/3 HP	1 at 1/3 HP	1 at 1/3 HP	1 at 1/3 HP
Motor RPM	1075	1075	1075	1075
Indoor Fan—Type	FC Centrifugal	FC Centrifugal	FC Centrifugal	FC Centrifugal
No. Used/Diameter in. [mm]	1/10x10 [254x254]	1/10x10 [254x254]	1/10x10 [254x254]	1/10x10 [254x254]
Drive Type	Belt (Adjustable)	Belt (Adjustable)	Belt (Adjustable)	Belt (Adjustable)
No. Speeds	Single	Single	Single	Single
No. Motors	1	1	1	1
Motor HP	1/2	1/2	3/4	3/4
Motor RPM	1725	1725	1725	1725
Motor Frame Size	48	48	56	56
Filter—Type	Disposable	Disposable	Disposable	Disposable
Furnished	Yes	Yes	Yes	Yes
(NO.) Size Recommended in. [mm x mm x mm]	(1)1x16x25 [25x406x635]	(1)1x16x25 [25x406x635]	(1)1x16x25 [25x406x635]	(1)1x16x25 [25x406x635]
	(1)1x16x25 [25x406x635]	(1)1x16x25 [25x406x635]	(1)1x16x25 [25x406x635]	(1)1x16x25 [25x406x635]
Refrigerant Charge Oz. [g]	68 [1928]	68 [1928]	68 [1928]	68 [1928]
Weights				
Net Weight lbs. [kg]	554 [251]	559 [254]	550 [249]	555 [252]
Ship Weight lbs. [kg]	561 [254]	566 [257]	557 [253]	562 [255]

See Page 48 for Notes.

[] Designates Metric Conversions

NOM. SIZES 3-5 TONS [10.6-17.6 kW]

Model RKPN- Series	A048CM13	A048DK08	A048DK10	A048DK13
Cooling Performance¹				CONTINUED →
Gross Cooling Capacity Btu [kW]	48,000 [14.06]	48,000 [14.06]	48,000 [14.06]	48,000 [14.06]
EER/SEER ²	11.6/14	11.6/14	11.6/14	11.6/14
Nominal CFM/AHRI Rated CFM [L/s]	1600/1500 [755/708]	1600/1500 [755/708]	1600/1500 [755/708]	1600/1500 [755/708]
AHRI Net Cooling Capacity Btu [kW]	46,000 [13.48]	46,000 [13.48]	46,000 [13.48]	46,000 [13.48]
Net Sensible Capacity Btu [kW]	34,000 [9.96]	34,000 [9.96]	34,000 [9.96]	34,000 [9.96]
Net Latent Capacity Btu [kW]	12,000 [3.52]	12,000 [3.52]	12,000 [3.52]	12,000 [3.52]
Net System Power kW	3.93	3.93	3.93	3.93
Heating Performance (Gas)³				
Heating Input Btu [kW]	135,000 [39.55]	80,000 [23.44]	100,000 [29.3]	135,000 [39.55]
Heating Output Btu [kW]	109,350 [32.04]	64,800 [18.99]	81,000 [23.73]	109,400 [32.05]
Temperature Rise Range °F [°C]	50-80 [27.8-44.4]	30-60 [16.7-33.3]	40-70 [22.2-38.9]	50-80 [27.8-44.4]
AFUE %	80	80	80	80
Steady State Efficiency (%)	81	81	81	81
No. Burners	6	4	5	6
No. Stages	1	1	1	1
Gas Connection Pipe Size in. [mm]	0.5 [12.7]	0.5 [12.7]	0.5 [12.7]	0.5 [12.7]
Compressor				
No./Type	1/Scroll	1/Scroll	1/Scroll	1/Scroll
Outdoor Sound Rating (dB)⁴	78	78	78	78
Outdoor Coil—Fin Type	Louvered	Louvered	Louvered	Louvered
Tube Type	MicroChannel	MicroChannel	MicroChannel	MicroChannel
MicroChannel Depth in. [mm]	0.7 [18]	0.7 [18]	0.7 [18]	0.7 [18]
Face Area sq. ft. [sq. m]	16.4 [1.52]	16.4 [1.52]	16.4 [1.52]	16.4 [1.52]
Rows / FPI [FPcm]	1 / 23 [9]	1 / 23 [9]	1 / 23 [9]	1 / 23 [9]
Indoor Coil—Fin Type	Louvered	Louvered	Louvered	Louvered
Tube Type	MicroChannel	MicroChannel	MicroChannel	MicroChannel
MicroChannel Depth in. [mm]	1.3 [32]	1.3 [32]	1.3 [32]	1.3 [32]
Face Area sq. ft. [sq. m]	4.8 [0.45]	4.8 [0.45]	4.8 [0.45]	4.8 [0.45]
Rows / FPI [FPcm]	1 / 20 [8]	1 / 20 [8]	1 / 20 [8]	1 / 20 [8]
Refrigerant Control	TX Valves	TX Valves	TX Valves	TX Valves
Drain Connection No./Size in. [mm]	1/0.75 [19.05]	1/0.75 [19.05]	1/0.75 [19.05]	1/0.75 [19.05]
Outdoor Fan—Type	Propeller	Propeller	Propeller	Propeller
No. Used/Diameter in. [mm]	1/24 [609.6]	1/24 [609.6]	1/24 [609.6]	1/24 [609.6]
Drive Type/No. Speeds	Direct/1	Direct/1	Direct/1	Direct/1
CFM [L/s]	3680 [1737]	3680 [1737]	3680 [1737]	3680 [1737]
No. Motors/HP	1 at 1/3 HP	1 at 1/3 HP	1 at 1/3 HP	1 at 1/3 HP
Motor RPM	1075	1075	1075	1075
Indoor Fan—Type	FC Centrifugal	FC Centrifugal	FC Centrifugal	FC Centrifugal
No. Used/Diameter in. [mm]	1/10x10 [254x254]	1/10x10 [254x254]	1/10x10 [254x254]	1/10x10 [254x254]
Drive Type	Belt (Adjustable)	Direct	Direct	Direct
No. Speeds	Single	Multiple	Multiple	Multiple
No. Motors	1	1	1	1
Motor HP	3/4	1/2	1/2	1/2
Motor RPM	1725	1075	1075	1075
Motor Frame Size	56	48	48	48
Filter—Type	Disposable	Disposable	Disposable	Disposable
Furnished	Yes	Yes	Yes	Yes
(NO.) Size Recommended in. [mm x mm x mm]	(1)1x16x25 [25x406x635] (1)1x16x25 [25x406x635]	(1)1x16x25 [25x406x635] (1)1x16x25 [25x406x635]	(1)1x16x25 [25x406x635] (1)1x16x25 [25x406x635]	(1)1x16x25 [25x406x635] (1)1x16x25 [25x406x635]
Refrigerant Charge Oz. [g]	68 [1928]	68 [1928]	68 [1928]	68 [1928]
Weights				
Net Weight lbs. [kg]	560 [254]	531 [241]	536 [243]	541 [245]
Ship Weight lbs. [kg]	567 [257]	538 [244]	543 [246]	548 [249]

See Page 48 for Notes.

[] Designates Metric Conversions

NOM. SIZES 3-5 TONS [10.6-17.6 kW]

Model RKPN- Series	A048DL08	A048DL10	A048DL13	A048DM08
Cooling Performance¹				CONTINUED →
Gross Cooling Capacity Btu [kW]	48,000 [14.06]	48,000 [14.06]	48,000 [14.06]	48,000 [14.06]
EER/SEER ²	11.6/14	11.6/14	11.6/14	11.6/14
Nominal CFM/AHRI Rated CFM [L/s]	1600/1500 [755/708]	1600/1500 [755/708]	1600/1500 [755/708]	1600/1500 [755/708]
AHRI Net Cooling Capacity Btu [kW]	46,000 [13.48]	46,000 [13.48]	46,000 [13.48]	46,000 [13.48]
Net Sensible Capacity Btu [kW]	34,000 [9.96]	34,000 [9.96]	34,000 [9.96]	34,000 [9.96]
Net Latent Capacity Btu [kW]	12,000 [3.52]	12,000 [3.52]	12,000 [3.52]	12,000 [3.52]
Net System Power kW	3.93	3.93	3.93	3.93
Heating Performance (Gas)³				
Heating Input Btu [kW]	80,000 [23.44]	100,000 [29.3]	135,000 [39.55]	80,000 [23.44]
Heating Output Btu [kW]	64,800 [18.99]	81,000 [23.73]	109,400 [32.05]	64,800 [18.99]
Temperature Rise Range °F [°C]	30-60 [16.7-33.3]	40-70 [22.2-38.9]	50-80 [27.8-44.4]	30-60 [16.7-33.3]
AFUE %	80	80	80	80
Steady State Efficiency (%)	81	81	81	81
No. Burners	4	5	6	4
No. Stages	1	1	1	1
Gas Connection Pipe Size in. [mm]	0.5 [12.7]	0.5 [12.7]	0.5 [12.7]	0.5 [12.7]
Compressor				
No./Type	1/Scroll	1/Scroll	1/Scroll	1/Scroll
Outdoor Sound Rating (dB)⁴	78	78	78	78
Outdoor Coil—Fin Type	Louvered	Louvered	Louvered	Louvered
Tube Type	MicroChannel	MicroChannel	MicroChannel	MicroChannel
MicroChannel Depth in. [mm]	0.7 [18]	0.7 [18]	0.7 [18]	0.7 [18]
Face Area sq. ft. [sq. m]	16.4 [1.52]	16.4 [1.52]	16.4 [1.52]	16.4 [1.52]
Rows / FPI [FPcm]	1 / 23 [9]	1 / 23 [9]	1 / 23 [9]	1 / 23 [9]
Indoor Coil—Fin Type	Louvered	Louvered	Louvered	Louvered
Tube Type	MicroChannel	MicroChannel	MicroChannel	MicroChannel
MicroChannel Depth in. [mm]	1.3 [32]	1.3 [32]	1.3 [32]	1.3 [32]
Face Area sq. ft. [sq. m]	4.8 [0.45]	4.8 [0.45]	4.8 [0.45]	4.8 [0.45]
Rows / FPI [FPcm]	1 / 20 [8]	1 / 20 [8]	1 / 20 [8]	1 / 20 [8]
Refrigerant Control	TX Valves	TX Valves	TX Valves	TX Valves
Drain Connection No./Size in. [mm]	1/0.75 [19.05]	1/0.75 [19.05]	1/0.75 [19.05]	1/0.75 [19.05]
Outdoor Fan—Type	Propeller	Propeller	Propeller	Propeller
No. Used/Diameter in. [mm]	1/24 [609.6]	1/24 [609.6]	1/24 [609.6]	1/24 [609.6]
Drive Type/No. Speeds	Direct/1	Direct/1	Direct/1	Direct/1
CFM [L/s]	3680 [1737]	3680 [1737]	3680 [1737]	3680 [1737]
No. Motors/HP	1 at 1/3 HP	1 at 1/3 HP	1 at 1/3 HP	1 at 1/3 HP
Motor RPM	1075	1075	1075	1075
Indoor Fan—Type	FC Centrifugal	FC Centrifugal	FC Centrifugal	FC Centrifugal
No. Used/Diameter in. [mm]	1/10x10 [254x254]	1/10x10 [254x254]	1/10x10 [254x254]	1/10x10 [254x254]
Drive Type	Belt (Adjustable)	Belt (Adjustable)	Belt (Adjustable)	Belt (Adjustable)
No. Speeds	Single	Single	Single	Single
No. Motors	1	1	1	1
Motor HP	1/2	1/2	1/2	3/4
Motor RPM	1725	1725	1725	1725
Motor Frame Size	48	48	48	56
Filter—Type	Disposable	Disposable	Disposable	Disposable
Furnished	Yes	Yes	Yes	Yes
(NO.) Size Recommended in. [mm x mm x mm]	(1)1x16x25 [25x406x635]	(1)1x16x25 [25x406x635]	(1)1x16x25 [25x406x635]	(1)1x16x25 [25x406x635]
	(1)1x16x25 [25x406x635]	(1)1x16x25 [25x406x635]	(1)1x16x25 [25x406x635]	(1)1x16x25 [25x406x635]
Refrigerant Charge Oz. [g]	68 [1928]	68 [1928]	68 [1928]	68 [1928]
Weights				
Net Weight lbs. [kg]	549 [249]	554 [251]	559 [254]	550 [249]
Ship Weight lbs. [kg]	556 [252]	561 [254]	566 [257]	557 [253]

See Page 48 for Notes.

[] Designates Metric Conversions

NOM. SIZES 3-5 TONS [10.6-17.6 kW]

Model RKPN- Series	A048DM10	A048DM13	A048JK08	A048JK10
Cooling Performance¹				CONTINUED →
Gross Cooling Capacity Btu [kW]	48,000 [14.06]	48,000 [14.06]	48,000 [14.06]	48,000 [14.06]
EER/SEER ²	11.6/14	11.6/14	11.6/14	11.6/14
Nominal CFM/AHRI Rated CFM [L/s]	1600/1500 [755/708]	1600/1500 [755/708]	1600/1500 [755/708]	1600/1500 [755/708]
AHRI Net Cooling Capacity Btu [kW]	46,000 [13.48]	46,000 [13.48]	46,000 [13.48]	46,000 [13.48]
Net Sensible Capacity Btu [kW]	34,000 [9.96]	34,000 [9.96]	34,000 [9.96]	34,000 [9.96]
Net Latent Capacity Btu [kW]	12,000 [3.52]	12,000 [3.52]	12,000 [3.52]	12,000 [3.52]
Net System Power kW	3.93	3.93	3.93	3.93
Heating Performance (Gas)³				
Heating Input Btu [kW]	100,000 [29.3]	135,000 [39.55]	80,000 [23.44]	100,000 [29.3]
Heating Output Btu [kW]	81,000 [23.73]	109,350 [32.04]	62,000 [18.17]	80,000 [23.44]
Temperature Rise Range °F [°C]	40-70 [22.2-38.9]	50-80 [27.8-44.4]	30-60 [16.7-33.3]	40-70 [22.2-38.9]
AFUE %	80	80	80	80
Steady State Efficiency (%)	81	81	80	80
No. Burners	5	6	4	5
No. Stages	1	1	1	1
Gas Connection Pipe Size in. [mm]	0.5 [12.7]	0.5 [12.7]	0.5 [12.7]	0.5 [12.7]
Compressor				
No./Type	1/Scroll	1/Scroll	1/Scroll	1/Scroll
Outdoor Sound Rating (dB)⁴	78	78	78	78
Outdoor Coil—Fin Type	Louvered	Louvered	Louvered	Louvered
Tube Type	MicroChannel	MicroChannel	MicroChannel	MicroChannel
MicroChannel Depth in. [mm]	0.7 [18]	0.7 [18]	0.7 [18]	0.7 [18]
Face Area sq. ft. [sq. m]	16.4 [1.52]	16.4 [1.52]	16.4 [1.52]	16.4 [1.52]
Rows / FPI [FPcm]	1 / 23 [9]	1 / 23 [9]	1 / 23 [9]	1 / 23 [9]
Indoor Coil—Fin Type	Louvered	Louvered	Louvered	Louvered
Tube Type	MicroChannel	MicroChannel	MicroChannel	MicroChannel
MicroChannel Depth in. [mm]	1.3 [32]	1.3 [32]	1.3 [32]	1.3 [32]
Face Area sq. ft. [sq. m]	4.8 [0.45]	4.8 [0.45]	4.8 [0.45]	4.8 [0.45]
Rows / FPI [FPcm]	1 / 20 [8]	1 / 20 [8]	1 / 20 [8]	1 / 20 [8]
Refrigerant Control	TX Valves	TX Valves	TX Valves	TX Valves
Drain Connection No./Size in. [mm]	1/0.75 [19.05]	1/0.75 [19.05]	1/0.75 [19.05]	1/0.75 [19.05]
Outdoor Fan—Type	Propeller	Propeller	Propeller	Propeller
No. Used/Diameter in. [mm]	1/24 [609.6]	1/24 [609.6]	1/24 [609.6]	1/24 [609.6]
Drive Type/No. Speeds	Direct/1	Direct/1	Direct/1	Direct/1
CFM [L/s]	3680 [1737]	3680 [1737]	3680 [1737]	3680 [1737]
No. Motors/HP	1 at 1/3 HP	1 at 1/3 HP	1 at 1/3 HP	1 at 1/3 HP
Motor RPM	1075	1075	1075	1075
Indoor Fan—Type	FC Centrifugal	FC Centrifugal	FC Centrifugal	FC Centrifugal
No. Used/Diameter in. [mm]	1/10x10 [254x254]	1/10x10 [254x254]	1/10x10 [254x254]	1/10x10 [254x254]
Drive Type	Belt (Adjustable)	Belt (Adjustable)	Direct	Direct
No. Speeds	Single	Single	Multiple	Multiple
No. Motors	1	1	1	1
Motor HP	3/4	3/4	1/2	1/2
Motor RPM	1725	1725	1075	1075
Motor Frame Size	56	56	48	48
Filter—Type	Disposable	Disposable	Disposable	Disposable
Furnished	Yes	Yes	Yes	Yes
(NO.) Size Recommended in. [mm x mm x mm]	(1)1x16x25 [25x406x635] (1)1x16x25 [25x406x635]	(1)1x16x25 [25x406x635] (1)1x16x25 [25x406x635]	(1)1x16x25 [25x406x635] (1)1x16x25 [25x406x635]	(1)1x16x25 [25x406x635] (1)1x16x25 [25x406x635]
Refrigerant Charge Oz. [g]	68 [1928]	68 [1928]	68 [1928]	68 [1928]
Weights				
Net Weight lbs. [kg]	555 [252]	560 [254]	531 [241]	536 [243]
Ship Weight lbs. [kg]	562 [255]	567 [257]	538 [244]	543 [246]

See Page 48 for Notes.

[] Designates Metric Conversions

NOM. SIZES 3-5 TONS [10.6-17.6 kW]

Model RKPN- Series	A048JK13	A048YL13	A048YM13	A060CK10
Cooling Performance¹				CONTINUED →
Gross Cooling Capacity Btu [kW]	48,000 [14.06]	48,000 [14.06]	48,000 [14.06]	60,000 [17.58]
EER/SEER ²	11.6/14	11.6/14	11.6/14	11.6/14
Nominal CFM/AHRI Rated CFM [L/s]	1600/1500 [755/708]	1600/1500 [755/708]	1600/1500 [755/708]	2000/1800 [944/849]
AHRI Net Cooling Capacity Btu [kW]	46,000 [13.48]	46,000 [13.48]	46,000 [13.48]	58,500 [17.14]
Net Sensible Capacity Btu [kW]	34,000 [9.96]	34,000 [9.96]	34,000 [9.96]	41,700 [12.22]
Net Latent Capacity Btu [kW]	12,000 [3.52]	12,000 [3.52]	12,000 [3.52]	16,800 [4.92]
Net System Power kW	3.93	3.93	3.93	4.95
Heating Performance (Gas)³				
Heating Input Btu [kW]	135,000 [39.55]	135,000 [39.55]	135,000 [39.55]	100,000 [29.3]
Heating Output Btu [kW]	108,000 [31.65]	109,400 [32.05]	109,400 [32.05]	81,000 [23.73]
Temperature Rise Range °F [°C]	50-80 [27.8-44.4]	50-80 [27.8-44.4]	50-80 [27.8-44.4]	25-55 [13.9-30.6]
AFUE %	80	80	80	80
Steady State Efficiency (%)	80	81	81	81
No. Burners	6	6	6	5
No. Stages	1	1	1	1
Gas Connection Pipe Size in. [mm]	0.5 [12.7]	0.5 [12.7]	0.5 [12.7]	0.5 [12.7]
Compressor				
No./Type	1/Scroll	1/Scroll	1/Scroll	1/Scroll
Outdoor Sound Rating (dB)⁴	78	78	78	83
Outdoor Coil—Fin Type	Louvered	Louvered	Louvered	Louvered
Tube Type	MicroChannel	MicroChannel	MicroChannel	MicroChannel
MicroChannel Depth in. [mm]	0.7 [18]	0.7 [18]	0.7 [18]	0.7 [18]
Face Area sq. ft. [sq. m]	16.4 [1.52]	16.4 [1.52]	16.4 [1.52]	16.4 [1.52]
Rows / FPI [FPcm]	1 / 23 [9]	1 / 23 [9]	1 / 23 [9]	1 / 23 [9]
Indoor Coil—Fin Type	Louvered	Louvered	Louvered	Louvered
Tube Type	MicroChannel	MicroChannel	MicroChannel	MicroChannel
MicroChannel Depth in. [mm]	1.3 [32]	1.3 [32]	1.3 [32]	1.3 [32]
Face Area sq. ft. [sq. m]	4.8 [0.45]	4.8 [0.45]	4.8 [0.45]	4.8 [0.45]
Rows / FPI [FPcm]	1 / 20 [8]	1 / 20 [8]	1 / 20 [8]	1 / 20 [8]
Refrigerant Control	TX Valves	TX Valves	TX Valves	TX Valves
Drain Connection No./Size in. [mm]	1/0.75 [19.05]	1/0.75 [19.05]	1/0.75 [19.05]	1/0.75 [19.05]
Outdoor Fan—Type	Propeller	Propeller	Propeller	Propeller
No. Used/Diameter in. [mm]	1/24 [609.6]	1/24 [609.6]	1/24 [609.6]	1/24 [609.6]
Drive Type/No. Speeds	Direct/1	Direct/1	Direct/1	Direct/1
CFM [L/s]	3680 [1737]	3680 [1737]	3680 [1737]	3930 [1855]
No. Motors/HP	1 at 1/3 HP	1 at 1/3 HP	1 at 1/3 HP	1 at 1/3 HP
Motor RPM	1075	1075	1075	1075
Indoor Fan—Type	FC Centrifugal	FC Centrifugal	FC Centrifugal	FC Centrifugal
No. Used/Diameter in. [mm]	1/10x10 [254x254]	1/10x10 [254x254]	1/10x10 [254x254]	1/10x10 [254x254]
Drive Type	Direct	Belt (Adjustable)	Belt (Adjustable)	Direct
No. Speeds	Multiple	Single	Single	Multiple
No. Motors	1	1	1	1
Motor HP	1/2	3/4	3/4	1
Motor RPM	1075	1725	1725	1075
Motor Frame Size	48	56	56	48
Filter—Type	Disposable	Disposable	Disposable	Disposable
Furnished	Yes	Yes	Yes	Yes
(NO.) Size Recommended in. [mm x mm x mm]	(1)1x16x25 [25x406x635]	(1)1x16x25 [25x406x635]	(1)1x16x25 [25x406x635]	(1)1x16x25 [25x406x635]
	(1)1x16x25 [25x406x635]	(1)1x16x25 [25x406x635]	(1)1x16x25 [25x406x635]	(1)1x16x25 [25x406x635]
Refrigerant Charge Oz. [g]	68 [1928]	68 [1928]	68 [1928]	63 [1786]
Weights				
Net Weight lbs. [kg]	541 [245]	555 [252]	560 [254]	550 [249]
Ship Weight lbs. [kg]	548 [249]	562 [255]	567 [257]	557 [253]

See Page 48 for Notes.

[] Designates Metric Conversions

NOM. SIZES 3-5 TONS [10.6-17.6 kW]

Model RKPN- Series	A060CK13	A060CL10	A060CL13	A060CM10
Cooling Performance¹				CONTINUED →
Gross Cooling Capacity Btu [kW]	60,000 [17.58]	60,000 [17.58]	60,000 [17.58]	60,000 [17.58]
EER/SEER ²	11.6/14	11.6/14	11.6/14	11.6/14
Nominal CFM/AHRI Rated CFM [L/s]	2000/1800 [944/849]	2000/1800 [944/849]	2000/1800 [944/849]	2000/1800 [944/849]
AHRI Net Cooling Capacity Btu [kW]	58,500 [17.14]	58,500 [17.14]	58,500 [17.14]	58,500 [17.14]
Net Sensible Capacity Btu [kW]	41,700 [12.22]	41,700 [12.22]	41,700 [12.22]	41,700 [12.22]
Net Latent Capacity Btu [kW]	16,800 [4.92]	16,800 [4.92]	16,800 [4.92]	16,800 [4.92]
Net System Power kW	4.95	4.95	4.95	4.95
Heating Performance (Gas)³				
Heating Input Btu [kW]	135,000 [39.55]	100,000 [29.3]	135,000 [39.55]	100,000 [29.3]
Heating Output Btu [kW]	109,400 [32.05]	81,000 [23.73]	109,400 [32.05]	81,000 [23.73]
Temperature Rise Range °F [°C]	40-70 [22.2-38.9]	25-55 [13.9-30.6]	40-70 [22.2-38.9]	25-55 [13.9-30.6]
AFUE %	80	80	80	80
Steady State Efficiency (%)	81	81	81	81
No. Burners	6	5	6	5
No. Stages	1	1	1	1
Gas Connection Pipe Size in. [mm]	0.5 [12.7]	0.5 [12.7]	0.5 [12.7]	0.5 [12.7]
Compressor				
No./Type	1/Scroll	1/Scroll	1/Scroll	1/Scroll
Outdoor Sound Rating (dB)⁴				
	83	83	83	83
Outdoor Coil—Fin Type				
Tube Type	Louvered	Louvered	Louvered	Louvered
MicroChannel Depth in. [mm]	MicroChannel	MicroChannel	MicroChannel	MicroChannel
Face Area sq. ft. [sq. m]	0.7 [18]	0.7 [18]	0.7 [18]	0.7 [18]
Rows / FPI [FPcm]	16.4 [1.52]	16.4 [1.52]	16.4 [1.52]	16.4 [1.52]
	1 / 23 [9]	1 / 23 [9]	1 / 23 [9]	1 / 23 [9]
Indoor Coil—Fin Type				
Tube Type	Louvered	Louvered	Louvered	Louvered
MicroChannel Depth in. [mm]	MicroChannel	MicroChannel	MicroChannel	MicroChannel
Face Area sq. ft. [sq. m]	1.3 [32]	1.3 [32]	1.3 [32]	1.3 [32]
Rows / FPI [FPcm]	4.8 [0.45]	4.8 [0.45]	4.8 [0.45]	4.8 [0.45]
	1 / 20 [8]	1 / 20 [8]	1 / 20 [8]	1 / 20 [8]
Refrigerant Control	TX Valves	TX Valves	TX Valves	TX Valves
Drain Connection No./Size in. [mm]	1/0.75 [19.05]	1/0.75 [19.05]	1/0.75 [19.05]	1/0.75 [19.05]
Outdoor Fan—Type				
No. Used/Diameter in. [mm]	Propeller	Propeller	Propeller	Propeller
Drive Type/No. Speeds	1/24 [609.6]	1/24 [609.6]	1/24 [609.6]	1/24 [609.6]
CFM [L/s]	Direct/1	Direct/1	Direct/1	Direct/1
No. Motors/HP	3930 [1855]	3930 [1855]	3930 [1855]	3930 [1855]
Motor RPM	1 at 1/3 HP	1 at 1/3 HP	1 at 1/3 HP	1 at 1/3 HP
	1075	1075	1075	1075
Indoor Fan—Type				
No. Used/Diameter in. [mm]	FC Centrifugal	FC Centrifugal	FC Centrifugal	FC Centrifugal
Drive Type	1/10x10 [254x254]	1/11x10 [279x254]	1/11x10 [279x254]	1/11x10 [279x254]
No. Speeds	Direct	Belt (Adjustable)	Belt (Adjustable)	Belt (Adjustable)
No. Motors	Multiple	Single	Single	Single
Motor HP	1	1	1	1
Motor RPM	1	3/4	3/4	1
Motor Frame Size	1075	1725	1725	1725
	48	56	56	56
Filter—Type				
Furnished	Disposable	Disposable	Disposable	Disposable
(NO.) Size Recommended in. [mm x mm x mm]	Yes	Yes	Yes	Yes
	(1)1x16x25 [25x406x635]	(1)1x16x25 [25x406x635]	(1)1x16x25 [25x406x635]	(1)1x16x25 [25x406x635]
	(1)1x16x25 [25x406x635]	(1)1x16x25 [25x406x635]	(1)1x16x25 [25x406x635]	(1)1x16x25 [25x406x635]
Refrigerant Charge Oz. [g]				
	63 [1786]	63 [1786]	63 [1786]	63 [1786]
Weights				
Net Weight lbs. [kg]	555 [252]	562 [255]	567 [257]	567 [257]
Ship Weight lbs. [kg]	562 [255]	569 [258]	574 [260]	574 [260]

See Page 48 for Notes.

[] Designates Metric Conversions

NOM. SIZES 3-5 TONS [10.6-17.6 kW]

Model RKPN- Series	A060CM13	A060DK10	A060DK13	A060DL10
Cooling Performance¹				CONTINUED →
Gross Cooling Capacity Btu [kW]	60,000 [17.58]	60,000 [17.58]	60,000 [17.58]	60,000 [17.58]
EER/SEER ²	11.6/14	11.6/14	11.6/14	11.6/14
Nominal CFM/AHRI Rated CFM [L/s]	2000/1800 [944/849]	2000/1800 [944/849]	2000/1800 [944/849]	2000/1800 [944/849]
AHRI Net Cooling Capacity Btu [kW]	58,500 [17.14]	58,500 [17.14]	58,500 [17.14]	58,500 [17.14]
Net Sensible Capacity Btu [kW]	41,700 [12.22]	41,700 [12.22]	41,700 [12.22]	41,700 [12.22]
Net Latent Capacity Btu [kW]	16,800 [4.92]	16,800 [4.92]	16,800 [4.92]	16,800 [4.92]
Net System Power kW	4.95	4.95	4.95	4.95
Heating Performance (Gas)³				
Heating Input Btu [kW]	135,000 [39.55]	100,000 [29.3]	135,000 [39.55]	100,000 [29.3]
Heating Output Btu [kW]	109,400 [32.05]	81,000 [23.73]	109,400 [32.05]	81,000 [23.73]
Temperature Rise Range °F [°C]	40-70 [22.2-38.9]	25-55 [13.9-30.6]	40-70 [22.2-38.9]	25-55 [13.9-30.6]
AFUE %	80	80	80	80
Steady State Efficiency (%)	81	81	81	81
No. Burners	6	5	6	5
No. Stages	1	1	1	1
Gas Connection Pipe Size in. [mm]	0.5 [12.7]	0.5 [12.7]	0.5 [12.7]	0.5 [12.7]
Compressor				
No./Type	1/Scroll	1/Scroll	1/Scroll	1/Scroll
Outdoor Sound Rating (dB)⁴	83	83	83	83
Outdoor Coil—Fin Type	Louvered	Louvered	Louvered	Louvered
Tube Type	MicroChannel	MicroChannel	MicroChannel	MicroChannel
MicroChannel Depth in. [mm]	0.7 [18]	0.7 [18]	0.7 [18]	0.7 [18]
Face Area sq. ft. [sq. m]	16.4 [1.52]	16.4 [1.52]	16.4 [1.52]	16.4 [1.52]
Rows / FPI [FPcm]	1 / 23 [9]	1 / 23 [9]	1 / 23 [9]	1 / 23 [9]
Indoor Coil—Fin Type	Louvered	Louvered	Louvered	Louvered
Tube Type	MicroChannel	MicroChannel	MicroChannel	MicroChannel
MicroChannel Depth in. [mm]	1.3 [32]	1.3 [32]	1.3 [32]	1.3 [32]
Face Area sq. ft. [sq. m]	4.8 [0.45]	4.8 [0.45]	4.8 [0.45]	4.8 [0.45]
Rows / FPI [FPcm]	1 / 20 [8]	1 / 20 [8]	1 / 20 [8]	1 / 20 [8]
Refrigerant Control	TX Valves	TX Valves	TX Valves	TX Valves
Drain Connection No./Size in. [mm]	1/0.75 [19.05]	1/0.75 [19.05]	1/0.75 [19.05]	1/0.75 [19.05]
Outdoor Fan—Type	Propeller	Propeller	Propeller	Propeller
No. Used/Diameter in. [mm]	1/24 [609.6]	1/24 [609.6]	1/24 [609.6]	1/24 [609.6]
Drive Type/No. Speeds	Direct/1	Direct/1	Direct/1	Direct/1
CFM [L/s]	3930 [1855]	3930 [1855]	3930 [1855]	3930 [1855]
No. Motors/HP	1 at 1/3 HP	1 at 1/3 HP	1 at 1/3 HP	1 at 1/3 HP
Motor RPM	1075	1075	1075	1075
Indoor Fan—Type	FC Centrifugal	FC Centrifugal	FC Centrifugal	FC Centrifugal
No. Used/Diameter in. [mm]	1/11x10 [279x254]	1/10x10 [254x254]	1/10x10 [254x254]	1/11x10 [279x254]
Drive Type	Belt (Adjustable)	Direct	Direct	Belt (Adjustable)
No. Speeds	Single	Multiple	Multiple	Single
No. Motors	1	1	1	1
Motor HP	1	1	1	3/4
Motor RPM	1725	1075	1075	1725
Motor Frame Size	56	48	48	56
Filter—Type	Disposable	Disposable	Disposable	Disposable
Furnished	Yes	Yes	Yes	Yes
(NO.) Size Recommended in. [mm x mm x mm]	(1)1x16x25 [25x406x635] (1)1x16x25 [25x406x635]	(1)1x16x25 [25x406x635] (1)1x16x25 [25x406x635]	(1)1x16x25 [25x406x635] (1)1x16x25 [25x406x635]	(1)1x16x25 [25x406x635] (1)1x16x25 [25x406x635]
Refrigerant Charge Oz. [g]	63 [1786]	63 [1786]	63 [1786]	63 [1786]
Weights				
Net Weight lbs. [kg]	572 [259]	550 [249]	555 [252]	562 [255]
Ship Weight lbs. [kg]	579 [263]	557 [253]	562 [255]	569 [258]

See Page 48 for Notes.

[] Designates Metric Conversions



NOM. SIZES 3-5 TONS [10.6-17.6 kW]

Model RKPN- Series	A060DL13	A060DM10	A060DM13	A060JK10
Cooling Performance¹				CONTINUED →
Gross Cooling Capacity Btu [kW]	60,000 [17.58]	60,000 [17.58]	60,000 [17.58]	60,000 [17.58]
EER/SEER ²	11.6/14	11.6/14	11.6/14	11.6/14
Nominal CFM/AHRI Rated CFM [L/s]	2000/1800 [944/849]	2000/1800 [944/849]	2000/1800 [944/849]	2000/1800 [944/849]
AHRI Net Cooling Capacity Btu [kW]	58,500 [17.14]	58,500 [17.14]	58,500 [17.14]	58,500 [17.14]
Net Sensible Capacity Btu [kW]	41,700 [12.22]	41,700 [12.22]	41,700 [12.22]	41,700 [12.22]
Net Latent Capacity Btu [kW]	16,800 [4.92]	16,800 [4.92]	16,800 [4.92]	16,800 [4.92]
Net System Power kW	4.95	4.95	4.95	4.95
Heating Performance (Gas)³				
Heating Input Btu [kW]	135,000 [39.55]	100,000 [29.3]	135,000 [39.55]	100,000 [29.3]
Heating Output Btu [kW]	109,400 [32.05]	81,000 [23.73]	109,400 [32.05]	80,000 [23.44]
Temperature Rise Range °F [°C]	40-70 [22.2-38.9]	25-55 [13.9-30.6]	40-70 [22.2-38.9]	25-55 [13.9-30.6]
AFUE %	80	80	80	80
Steady State Efficiency (%)	81	81	81	80
No. Burners	6	5	6	5
No. Stages	1	1	1	1
Gas Connection Pipe Size in. [mm]	0.5 [12.7]	0.5 [12.7]	0.5 [12.7]	0.5 [12.7]
Compressor				
No./Type	1/Scroll	1/Scroll	1/Scroll	1/Scroll
Outdoor Sound Rating (dB)⁴	83	83	83	83
Outdoor Coil—Fin Type	Louvered	Louvered	Louvered	Louvered
Tube Type	MicroChannel	MicroChannel	MicroChannel	MicroChannel
MicroChannel Depth in. [mm]	0.7 [18]	0.7 [18]	0.7 [18]	0.7 [18]
Face Area sq. ft. [sq. m]	16.4 [1.52]	16.4 [1.52]	16.4 [1.52]	16.4 [1.52]
Rows / FPI [FPcm]	1 / 23 [9]	1 / 23 [9]	1 / 23 [9]	1 / 23 [9]
Indoor Coil—Fin Type	Louvered	Louvered	Louvered	Louvered
Tube Type	MicroChannel	MicroChannel	MicroChannel	MicroChannel
MicroChannel Depth in. [mm]	1.3 [32]	1.3 [32]	1.3 [32]	1.3 [32]
Face Area sq. ft. [sq. m]	4.8 [0.45]	4.8 [0.45]	4.8 [0.45]	4.8 [0.45]
Rows / FPI [FPcm]	1 / 20 [8]	1 / 20 [8]	1 / 20 [8]	1 / 20 [8]
Refrigerant Control	TX Valves	TX Valves	TX Valves	TX Valves
Drain Connection No./Size in. [mm]	1/0.75 [19.05]	1/0.75 [19.05]	1/0.75 [19.05]	1/0.75 [19.05]
Outdoor Fan—Type	Propeller	Propeller	Propeller	Propeller
No. Used/Diameter in. [mm]	1/24 [609.6]	1/24 [609.6]	1/24 [609.6]	1/24 [609.6]
Drive Type/No. Speeds	Direct/1	Direct/1	Direct/1	Direct/1
CFM [L/s]	3930 [1855]	3930 [1855]	3930 [1855]	3930 [1855]
No. Motors/HP	1 at 1/3 HP	1 at 1/3 HP	1 at 1/3 HP	1 at 1/3 HP
Motor RPM	1075	1075	1075	1075
Indoor Fan—Type	FC Centrifugal	FC Centrifugal	FC Centrifugal	FC Centrifugal
No. Used/Diameter in. [mm]	1/11x10 [279x254]	1/11x10 [279x254]	1/11x10 [279x254]	1/10x10 [254x254]
Drive Type	Belt (Adjustable)	Belt (Adjustable)	Belt (Adjustable)	Direct
No. Speeds	Single	Single	Single	Multiple
No. Motors	1	1	1	1
Motor HP	3/4	1	1	1
Motor RPM	1725	1725	1725	1075
Motor Frame Size	56	56	56	48
Filter—Type	Disposable	Disposable	Disposable	Disposable
Furnished	Yes	Yes	Yes	Yes
(NO.) Size Recommended in. [mm x mm x mm]	(1)1x16x25 [25x406x635] (1)1x16x25 [25x406x635]	(1)1x16x25 [25x406x635] (1)1x16x25 [25x406x635]	(1)1x16x25 [25x406x635] (1)1x16x25 [25x406x635]	(1)1x16x25 [25x406x635] (1)1x16x25 [25x406x635]
Refrigerant Charge Oz. [g]	63 [1786]	63 [1786]	63 [1786]	63 [1786]
Weights				
Net Weight lbs. [kg]	567 [257]	567 [257]	572 [259]	550 [249]
Ship Weight lbs. [kg]	574 [260]	574 [260]	579 [263]	557 [253]

See Page 48 for Notes.

[] Designates Metric Conversions

NOM. SIZES 3-5 TONS [10.6-17.6 kW]

Model RKPN- Series	AC060JK13	A060YL13	A060YM13
Cooling Performance¹			
Gross Cooling Capacity Btu [kW]	60,000 [17.58]	60,000 [17.58]	60,000 [17.58]
EER/SEER ²	11.6/14	11.6/14	11.6/14
Nominal CFM/AHRI Rated CFM [L/s]	2000/1800 [944/849]	2000/1800 [944/849]	2000/1800 [944/849]
AHRI Net Cooling Capacity Btu [kW]	58,500 [17.14]	58,500 [17.14]	58,500 [17.14]
Net Sensible Capacity Btu [kW]	41,700 [12.22]	41,700 [12.22]	41,700 [12.22]
Net Latent Capacity Btu [kW]	16,800 [4.92]	16,800 [4.92]	16,800 [4.92]
Net System Power kW	4.95	4.95	4.95
Heating Performance (Gas)³			
Heating Input Btu [kW]	135,000 [39.55]	135,000 [39.55]	135,000 [39.55]
Heating Output Btu [kW]	108,000 [31.65]	109,400 [32.05]	109,400 [32.05]
Temperature Rise Range °F [°C]	40-70 [22.2-38.9]	40-70 [22.2-38.9]	40-70 [22.2-38.9]
AFUE %	80	80	80
Steady State Efficiency (%)	80	81	81
No. Burners	6	6	6
No. Stages	1	1	1
Gas Connection Pipe Size in. [mm]	0.5 [12.7]	0.5 [12.7]	0.5 [12.7]
Compressor			
No./Type	1/Scroll	1/Scroll	1/Scroll
Outdoor Sound Rating (dB)⁴			
	83	83	83
Outdoor Coil—Fin Type			
Tube Type	Louvered	Louvered	Louvered
MicroChannel Depth in. [mm]	MicroChannel	MicroChannel	MicroChannel
Face Area sq. ft. [sq. m]	0.7 [18]	0.7 [18]	0.7 [18]
Rows / FPI [FPcm]	16.4 [1.52]	16.4 [1.52]	16.4 [1.52]
	1 / 23 [9]	1 / 23 [9]	1 / 23 [9]
Indoor Coil—Fin Type			
Tube Type	Louvered	Louvered	Louvered
MicroChannel Depth in. [mm]	MicroChannel	MicroChannel	MicroChannel
Face Area sq. ft. [sq. m]	1.3 [32]	1.3 [32]	1.3 [32]
Rows / FPI [FPcm]	4.8 [0.45]	4.8 [0.45]	4.8 [0.45]
	1 / 20 [8]	1 / 20 [8]	1 / 20 [8]
Refrigerant Control	TX Valves	TX Valves	TX Valves
Drain Connection No./Size in. [mm]	1/0.75 [19.05]	1/0.75 [19.05]	1/0.75 [19.05]
Outdoor Fan—Type			
No. Used/Diameter in. [mm]	Propeller	Propeller	Propeller
Drive Type/No. Speeds	1/24 [609.6]	1/24 [609.6]	1/24 [609.6]
CFM [L/s]	Direct/1	Direct/1	Direct/1
No. Motors/HP	3930 [1855]	3930 [1855]	3930 [1855]
Motor RPM	1 at 1/3 HP	1 at 1/3 HP	1 at 1/3 HP
	1075	1075	1075
Indoor Fan—Type			
No. Used/Diameter in. [mm]	FC Centrifugal	FC Centrifugal	FC Centrifugal
Drive Type	1/10x10 [254x254]	1/10x10 [254x254]	1/10x10 [254x254]
No. Speeds	Direct	Belt (Adjustable)	Belt (Adjustable)
No. Motors	Multiple	Single	Single
Motor HP	1	1	1
Motor RPM	1	3/4	1
Motor Frame Size	1075	1725	1725
	48	56	56
Filter—Type			
Furnished	Disposable	Disposable	Disposable
(NO.) Size Recommended in. [mm x mm x mm]	Yes	Yes	Yes
	(1)1x16x25 [25x406x635]	(1)1x16x25 [25x406x635]	(1)1x16x25 [25x406x635]
	(1)1x16x25 [25x406x635]	(1)1x16x25 [25x406x635]	(1)1x16x25 [25x406x635]
Refrigerant Charge Oz. [g]			
	63 [1786]	63 [1786]	63 [1786]
Weights			
Net Weight lbs. [kg]	555 [252]	555 [252]	560 [254]
Ship Weight lbs. [kg]	562 [255]	562 [255]	567 [257]

See Page 48 for Notes.

[] Designates Metric Conversions



NOM. SIZES 3-5 TONS [10.6-17.6 kW]

Model RKQN- Series	A036CK08	A036CK12	A036CL08	A036CL12
Cooling Performance¹				CONTINUED →
Gross Cooling Capacity Btu [kW]	36,200 [10.61]	36,200 [10.61]	36,200 [10.61]	36,200 [10.61]
EER/SEER ²	12.5/15	12.5/15	12.5/15	12.5/15
Nominal CFM/AHRI Rated CFM [L/s]	1200/1250 [566/590]	1200/1250 [566/590]	1200/1250 [566/590]	1200/1250 [566/590]
AHRI Net Cooling Capacity Btu [kW]	35,400 [10.37]	35,400 [10.37]	35,400 [10.37]	35,400 [10.37]
Net Sensible Capacity Btu [kW]	26,200 [7.68]	26,200 [7.68]	26,200 [7.68]	26,200 [7.68]
Net Latent Capacity Btu [kW]	9,200 [2.7]	9,200 [2.7]	9,200 [2.7]	9,200 [2.7]
Net System Power kW	2.72	2.72	2.72	2.72
Heating Performance (Gas)³				
Heating Input Btu [kW]	80,000 [23.44]	120,000 [35.16]	80,000 [23.44]	120,000 [35.16]
Heating Output Btu [kW]	64,800 [18.99]	97,200 [28.48]	64,800 [18.99]	97,200 [28.48]
Temperature Rise Range °F [°C]	30-60 [16.7-33.3]	50-80 [27.8-44.4]	30-60 [16.7-33.3]	50-80 [27.8-44.4]
AFUE %	80	80	80	80
Steady State Efficiency (%)	81	81	81	81
No. Burners	4	6	4	6
No. Stages	1	1	1	1
Gas Connection Pipe Size in. [mm]	0.5 [12.7]	0.5 [12.7]	0.5 [12.7]	0.5 [12.7]
Compressor				
No./Type	1/Scroll	1/Scroll	1/Scroll	1/Scroll
Outdoor Sound Rating (dB)⁴	78	78	78	78
Outdoor Coil—Fin Type	Louvered	Louvered	Louvered	Louvered
Tube Type	MicroChannel	MicroChannel	MicroChannel	MicroChannel
MicroChannel Depth in. [mm]	0.7 [18]	0.7 [18]	0.7 [18]	0.7 [18]
Face Area sq. ft. [sq. m]	13.9 [1.29]	13.9 [1.29]	13.9 [1.29]	13.9 [1.29]
Rows / FPI [FPcm]	1 / 23 [9]	1 / 23 [9]	1 / 23 [9]	1 / 23 [9]
Indoor Coil—Fin Type	Louvered	Louvered	Louvered	Louvered
Tube Type	MicroChannel	MicroChannel	MicroChannel	MicroChannel
MicroChannel Depth in. [mm]	1 [25]	1 [25]	1 [25]	1 [25]
Face Area sq. ft. [sq. m]	4.8 [0.45]	4.8 [0.45]	4.8 [0.45]	4.8 [0.45]
Rows / FPI [FPcm]	1 / 20 [8]	1 / 20 [8]	1 / 20 [8]	1 / 20 [8]
Refrigerant Control	TX Valves	TX Valves	TX Valves	TX Valves
Drain Connection No./Size in. [mm]	1/0.75 [19.05]	1/0.75 [19.05]	1/0.75 [19.05]	1/0.75 [19.05]
Outdoor Fan—Type	Propeller	Propeller	Propeller	Propeller
No. Used/Diameter in. [mm]	1/24 [609.6]	1/24 [609.6]	1/24 [609.6]	1/24 [609.6]
Drive Type/No. Speeds	Direct/1	Direct/1	Direct/1	Direct/1
CFM [L/s]	3680 [1737]	3680 [1737]	3680 [1737]	3680 [1737]
No. Motors/HP	1 at 1/3 HP	1 at 1/3 HP	1 at 1/3 HP	1 at 1/3 HP
Motor RPM	1075	1075	1075	1075
Indoor Fan—Type	FC Centrifugal	FC Centrifugal	FC Centrifugal	FC Centrifugal
No. Used/Diameter in. [mm]	1/10x10 [254x254]	1/10x10 [254x254]	1/10x10 [254x254]	1/10x10 [254x254]
Drive Type	Direct	Direct	Belt (Adjustable)	Belt (Adjustable)
No. Speeds	Multiple	Multiple	Single	Single
No. Motors	1	1	1	1
Motor HP	1/2	1/2	1/2	1/2
Motor RPM	1075	1075	1725	1725
Motor Frame Size	48	48	48	48
Filter—Type	Disposable	Disposable	Disposable	Disposable
Furnished	Yes	Yes	Yes	Yes
(NO.) Size Recommended in. [mm x mm x mm]	(1)1x16x25 [25x406x635] (1)1x16x25 [25x406x635]	(1)1x16x25 [25x406x635] (1)1x16x25 [25x406x635]	(1)1x16x25 [25x406x635] (1)1x16x25 [25x406x635]	(1)1x16x25 [25x406x635] (1)1x16x25 [25x406x635]
Refrigerant Charge Oz. [g]	54 [1531]	54 [1531]	54 [1531]	54 [1531]
Weights				
Net Weight lbs. [kg]	507 [230]	517 [235]	525 [238]	517 [235]
Ship Weight lbs. [kg]	514 [233]	525 [238]	532 [241]	525 [238]

See Page 48 for Notes.

[] Designates Metric Conversions

NOM. SIZES 3-5 TONS [10.6-17.6 kW]

Model RKQN- Series	A036CM08	A036CM12	A036DK08	A036DK12
Cooling Performance¹				CONTINUED →
Gross Cooling Capacity Btu [kW]	36,200 [10.61]	36,200 [10.61]	36,200 [10.61]	36,200 [10.61]
EER/SEER ²	12.5/15	12.5/15	12.5/15	12.5/15
Nominal CFM/AHRI Rated CFM [L/s]	1200/1250 [566/590]	1200/1250 [566/590]	1200/1250 [566/590]	1200/1250 [566/590]
AHRI Net Cooling Capacity Btu [kW]	35,400 [10.37]	35,400 [10.37]	35,400 [10.37]	35,400 [10.37]
Net Sensible Capacity Btu [kW]	26,200 [7.68]	26,200 [7.68]	26,200 [7.68]	26,200 [7.68]
Net Latent Capacity Btu [kW]	9,200 [2.7]	9,200 [2.7]	9,200 [2.7]	9,200 [2.7]
Net System Power kW	2.72	2.72	2.72	2.72
Heating Performance (Gas)³				
Heating Input Btu [kW]	80,000 [23.44]	120,000 [35.16]	80,000 [23.44]	120,000 [35.16]
Heating Output Btu [kW]	64,800 [18.99]	97,200 [28.48]	64,800 [18.99]	97,200 [28.48]
Temperature Rise Range °F [°C]	30-60 [16.7-33.3]	50-80 [27.8-44.4]	30-60 [16.7-33.3]	50-80 [27.8-44.4]
AFUE %	80	80	80	80
Steady State Efficiency (%)	81	81	81	81
No. Burners	4	6	4	6
No. Stages	1	1	1	1
Gas Connection Pipe Size in. [mm]	0.5 [12.7]	0.5 [12.7]	0.5 [12.7]	0.5 [12.7]
Compressor				
No./Type	1/Scroll	1/Scroll	1/Scroll	1/Scroll
Outdoor Sound Rating (dB)⁴	78	78	78	78
Outdoor Coil—Fin Type	Louvered	Louvered	Louvered	Louvered
Tube Type	MicroChannel	MicroChannel	MicroChannel	MicroChannel
MicroChannel Depth in. [mm]	0.7 [18]	0.7 [18]	0.7 [18]	0.7 [18]
Face Area sq. ft. [sq. m]	13.9 [1.29]	13.9 [1.29]	13.9 [1.29]	13.9 [1.29]
Rows / FPI [FPcm]	1 / 23 [9]	1 / 23 [9]	1 / 23 [9]	1 / 23 [9]
Indoor Coil—Fin Type	Louvered	Louvered	Louvered	Louvered
Tube Type	MicroChannel	MicroChannel	MicroChannel	MicroChannel
MicroChannel Depth in. [mm]	1 [25]	1 [25]	1 [25]	1 [25]
Face Area sq. ft. [sq. m]	4.8 [0.45]	4.8 [0.45]	4.8 [0.45]	4.8 [0.45]
Rows / FPI [FPcm]	1 / 20 [8]	1 / 20 [8]	1 / 20 [8]	1 / 20 [8]
Refrigerant Control	TX Valves	TX Valves	TX Valves	TX Valves
Drain Connection No./Size in. [mm]	1/0.75 [19.05]	1/0.75 [19.05]	1/0.75 [19.05]	1/0.75 [19.05]
Outdoor Fan—Type	Propeller	Propeller	Propeller	Propeller
No. Used/Diameter in. [mm]	1/24 [609.6]	1/24 [609.6]	1/24 [609.6]	1/24 [609.6]
Drive Type/No. Speeds	Direct/1	Direct/1	Direct/1	Direct/1
CFM [L/s]	3680 [1737]	3680 [1737]	3680 [1737]	3680 [1737]
No. Motors/HP	1 at 1/3 HP	1 at 1/3 HP	1 at 1/3 HP	1 at 1/3 HP
Motor RPM	1075	1075	1075	1075
Indoor Fan—Type	FC Centrifugal	FC Centrifugal	FC Centrifugal	FC Centrifugal
No. Used/Diameter in. [mm]	1/10x10 [254x254]	1/10x10 [254x254]	1/10x10 [254x254]	1/10x10 [254x254]
Drive Type	Belt (Adjustable)	Belt (Adjustable)	Direct	Direct
No. Speeds	Single	Single	Multiple	Multiple
No. Motors	1	1	1	1
Motor HP	1/2	1/2	1/2	1/2
Motor RPM	1725	1725	1075	1075
Motor Frame Size	48	48	48	48
Filter—Type	Disposable	Disposable	Disposable	Disposable
Furnished	Yes	Yes	Yes	Yes
(NO.) Size Recommended in. [mm x mm x mm]	(1)1x16x25 [25x406x635] (1)1x16x25 [25x406x635]	(1)1x16x25 [25x406x635] (1)1x16x25 [25x406x635]	(1)1x16x25 [25x406x635] (1)1x16x25 [25x406x635]	(1)1x16x25 [25x406x635] (1)1x16x25 [25x406x635]
Refrigerant Charge Oz. [g]	54 [1531]	54 [1531]	54 [1531]	54 [1531]
Weights				
Net Weight lbs. [kg]	525 [238]	517 [235]	507 [230]	517 [235]
Ship Weight lbs. [kg]	532 [241]	525 [238]	514 [233]	525 [238]

See Page 48 for Notes.

[] Designates Metric Conversions



NOM. SIZES 3-5 TONS [10.6-17.6 kW]

Model RKQN- Series	A036DL08	A036DL12	A036DM08	A036DM12
Cooling Performance¹				CONTINUED →
Gross Cooling Capacity Btu [kW]	36,200 [10.61]	36,200 [10.61]	36,200 [10.61]	36,200 [10.61]
EER/SEER ²	12.5/15	12.5/15	12.5/15	12.5/15
Nominal CFM/AHRI Rated CFM [L/s]	1200/1250 [566/590]	1200/1250 [566/590]	1200/1250 [566/590]	1200/1250 [566/590]
AHRI Net Cooling Capacity Btu [kW]	35,400 [10.37]	35,400 [10.37]	35,400 [10.37]	35,400 [10.37]
Net Sensible Capacity Btu [kW]	26,200 [7.68]	26,200 [7.68]	26,200 [7.68]	26,200 [7.68]
Net Latent Capacity Btu [kW]	9,200 [2.7]	9,200 [2.7]	9,200 [2.7]	9,200 [2.7]
Net System Power kW	2.72	2.72	2.72	2.72
Heating Performance (Gas)³				
Heating Input Btu [kW]	80,000 [23.44]	120,000 [35.16]	80,000 [23.44]	120,000 [35.16]
Heating Output Btu [kW]	64,800 [18.99]	97,200 [28.48]	64,800 [18.99]	97,200 [28.48]
Temperature Rise Range °F [°C]	30-60 [16.7-33.3]	50-80 [27.8-44.4]	30-60 [16.7-33.3]	50-80 [27.8-44.4]
AFUE %	80	80	80	80
Steady State Efficiency (%)	81	81	81	81
No. Burners	4	6	4	6
No. Stages	1	1	1	1
Gas Connection Pipe Size in. [mm]	0.5 [12.7]	0.5 [12.7]	0.5 [12.7]	0.5 [12.7]
Compressor				
No./Type	1/Scroll	1/Scroll	1/Scroll	1/Scroll
Outdoor Sound Rating (dB)⁴	78	78	78	78
Outdoor Coil—Fin Type	Louvered	Louvered	Louvered	Louvered
Tube Type	MicroChannel	MicroChannel	MicroChannel	MicroChannel
MicroChannel Depth in. [mm]	0.7 [18]	0.7 [18]	0.7 [18]	0.7 [18]
Face Area sq. ft. [sq. m]	13.9 [1.29]	13.9 [1.29]	13.9 [1.29]	13.9 [1.29]
Rows / FPI [FPcm]	1 / 23 [9]	1 / 23 [9]	1 / 23 [9]	1 / 23 [9]
Indoor Coil—Fin Type	Louvered	Louvered	Louvered	Louvered
Tube Type	MicroChannel	MicroChannel	MicroChannel	MicroChannel
MicroChannel Depth in. [mm]	1 [25]	1 [25]	1 [25]	1 [25]
Face Area sq. ft. [sq. m]	4.8 [0.45]	4.8 [0.45]	4.8 [0.45]	4.8 [0.45]
Rows / FPI [FPcm]	1 / 20 [8]	1 / 20 [8]	1 / 20 [8]	1 / 20 [8]
Refrigerant Control	TX Valves	TX Valves	TX Valves	TX Valves
Drain Connection No./Size in. [mm]	1/0.75 [19.05]	1/0.75 [19.05]	1/0.75 [19.05]	1/0.75 [19.05]
Outdoor Fan—Type	Propeller	Propeller	Propeller	Propeller
No. Used/Diameter in. [mm]	1/24 [609.6]	1/24 [609.6]	1/24 [609.6]	1/24 [609.6]
Drive Type/No. Speeds	Direct/1	Direct/1	Direct/1	Direct/1
CFM [L/s]	3680 [1737]	3680 [1737]	3680 [1737]	3680 [1737]
No. Motors/HP	1 at 1/3 HP	1 at 1/3 HP	1 at 1/3 HP	1 at 1/3 HP
Motor RPM	1075	1075	1075	1075
Indoor Fan—Type	FC Centrifugal	FC Centrifugal	FC Centrifugal	FC Centrifugal
No. Used/Diameter in. [mm]	1/10x10 [254x254]	1/10x10 [254x254]	1/10x10 [254x254]	1/10x10 [254x254]
Drive Type	Belt (Adjustable)	Belt (Adjustable)	Belt (Adjustable)	Belt (Adjustable)
No. Speeds	Single	Single	Single	Single
No. Motors	1	1	1	1
Motor HP	1/2	1/2	1/2	1/2
Motor RPM	1725	1725	1725	1725
Motor Frame Size	48	48	48	48
Filter—Type	Disposable	Disposable	Disposable	Disposable
Furnished	Yes	Yes	Yes	Yes
(NO.) Size Recommended in. [mm x mm x mm]	(1)1x16x25 [25x406x635]	(1)1x16x25 [25x406x635]	(1)1x16x25 [25x406x635]	(1)1x16x25 [25x406x635]
	(1)1x16x25 [25x406x635]	(1)1x16x25 [25x406x635]	(1)1x16x25 [25x406x635]	(1)1x16x25 [25x406x635]
Refrigerant Charge Oz. [g]	54 [1531]	54 [1531]	54 [1531]	54 [1531]
Weights				
Net Weight lbs. [kg]	525 [238]	517 [235]	525 [238]	517 [235]
Ship Weight lbs. [kg]	532 [241]	525 [238]	532 [241]	525 [238]

See Page 48 for Notes.

[] Designates Metric Conversions

NOM. SIZES 3-5 TONS [10.6-17.6 kW]

Model RKQN- Series	A036JK08	A036JK12	A048CK08	A048CK10
Cooling Performance¹				CONTINUED →
Gross Cooling Capacity Btu [kW]	36,200 [10.61]	36,200 [10.61]	48,000 [14.06]	48,000 [14.06]
EER/SEER ²	12.5/15	12.5/15	12.5/15	12.5/15
Nominal CFM/AHRI Rated CFM [L/s]	1200/1250 [566/590]	1200/1250 [566/590]	1600/1600 [755/755]	1600/1600 [755/755]
AHRI Net Cooling Capacity Btu [kW]	35,400 [10.37]	35,400 [10.37]	46,500 [13.62]	46,500 [13.62]
Net Sensible Capacity Btu [kW]	26,200 [7.68]	26,200 [7.68]	35,700 [10.46]	35,700 [10.46]
Net Latent Capacity Btu [kW]	9,200 [2.7]	9,200 [2.7]	10,800 [3.16]	10,800 [3.16]
Net System Power kW	2.72	2.72	3.69	3.69
Heating Performance (Gas)³				
Heating Input Btu [kW]	80,000 [23.44]	120,000 [35.16]	80,000 [23.44]	100,000 [29.3]
Heating Output Btu [kW]	64,000 [18.76]	96,000 [28.13]	64,800 [18.99]	81,000 [23.73]
Temperature Rise Range °F [°C]	30-60 [16.7-33.3]	50-80 [27.8-44.4]	30-60 [16.7-33.3]	40-70 [22.2-38.9]
AFUE %	80	80	80	80
Steady State Efficiency (%)	80	80	81	81
No. Burners	4	6	4	5
No. Stages	1	1	1	1
Gas Connection Pipe Size in. [mm]	0.5 [12.7]	0.5 [12.7]	0.5 [12.7]	0.5 [12.7]
Compressor				
No./Type	1/Scroll	1/Scroll	1/Scroll	1/Scroll
Outdoor Sound Rating (dB)⁴	78	78	78	78
Outdoor Coil—Fin Type	Louvered	Louvered	Louvered	Louvered
Tube Type	MicroChannel	MicroChannel	MicroChannel	MicroChannel
MicroChannel Depth in. [mm]	0.7 [18]	0.7 [18]	0.7 [18]	0.7 [18]
Face Area sq. ft. [sq. m]	13.9 [1.29]	13.9 [1.29]	16.4 [1.52]	16.4 [1.52]
Rows / FPI [FPcm]	1 / 23 [9]	1 / 23 [9]	1 / 23 [9]	1 / 23 [9]
Indoor Coil—Fin Type	Louvered	Louvered	Louvered	Louvered
Tube Type	MicroChannel	MicroChannel	MicroChannel	MicroChannel
MicroChannel Depth in. [mm]	1 [25]	1 [25]	1.3 [32]	1.3 [32]
Face Area sq. ft. [sq. m]	4.8 [0.45]	4.8 [0.45]	4.8 [0.45]	4.8 [0.45]
Rows / FPI [FPcm]	1 / 20 [8]	1 / 20 [8]	1 / 20 [8]	1 / 20 [8]
Refrigerant Control	TX Valves	TX Valves	TX Valves	TX Valves
Drain Connection No./Size in. [mm]	1/0.75 [19.05]	1/0.75 [19.05]	1/0.75 [19.05]	1/0.75 [19.05]
Outdoor Fan—Type	Propeller	Propeller	Propeller	Propeller
No. Used/Diameter in. [mm]	1/24 [609.6]	1/24 [609.6]	1/24 [609.6]	1/24 [609.6]
Drive Type/No. Speeds	Direct/1	Direct/1	Direct/1	Direct/1
CFM [L/s]	3680 [1737]	3680 [1737]	3680 [1737]	3680 [1737]
No. Motors/HP	1 at 1/3 HP	1 at 1/3 HP	1 at 1/3 HP	1 at 1/3 HP
Motor RPM	1075	1075	1075	1075
Indoor Fan—Type	FC Centrifugal	FC Centrifugal	FC Centrifugal	FC Centrifugal
No. Used/Diameter in. [mm]	1/10x10 [254x254]	1/10x10 [254x254]	1/10x10 [254x254]	1/10x10 [254x254]
Drive Type	Direct	Direct	Direct	Direct
No. Speeds	Multiple	Multiple	Multiple	Multiple
No. Motors	1	1	1	1
Motor HP	1/2	1/2	3/4	3/4
Motor RPM	1075	1075	1075	1075
Motor Frame Size	48	48	48	48
Filter—Type	Disposable	Disposable	Disposable	Disposable
Furnished	Yes	Yes	Yes	Yes
(NO.) Size Recommended in. [mm x mm x mm]	(1)1x16x25 [25x406x635]	(1)1x16x25 [25x406x635]	(1)1x16x25 [25x406x635]	(1)1x16x25 [25x406x635]
	(1)1x16x25 [25x406x635]	(1)1x16x25 [25x406x635]	(1)1x16x25 [25x406x635]	(1)1x16x25 [25x406x635]
Refrigerant Charge Oz. [g]	54 [1531]	54 [1531]	68 [1928]	68 [1928]
Weights				
Net Weight lbs. [kg]	507 [230]	517 [235]	531 [241]	536 [243]
Ship Weight lbs. [kg]	514 [233]	525 [238]	538 [244]	543 [246]

See Page 48 for Notes.

[] Designates Metric Conversions



NOM. SIZES 3-5 TONS [10.6-17.6 kW]

Model RKQN- Series	A048CK13	A048CL08	A048CL10	A048CL13
Cooling Performance¹				CONTINUED →
Gross Cooling Capacity Btu [kW]	48,000 [14.06]	48,000 [14.06]	48,000 [14.06]	48,000 [14.06]
EER/SEER ²	12.5/15	12.5/15	12.5/15	12.5/15
Nominal CFM/AHRI Rated CFM [L/s]	1600/1600 [755/755]	1600/1600 [755/755]	1600/1600 [755/755]	1600/1600 [755/755]
AHRI Net Cooling Capacity Btu [kW]	46,500 [13.62]	46,500 [13.62]	46,500 [13.62]	46,500 [13.62]
Net Sensible Capacity Btu [kW]	35,700 [10.46]	35,700 [10.46]	35,700 [10.46]	35,700 [10.46]
Net Latent Capacity Btu [kW]	10,800 [3.16]	10,800 [3.16]	10,800 [3.16]	10,800 [3.16]
Net System Power kW	3.69	3.69	3.69	3.69
Heating Performance (Gas)³				
Heating Input Btu [kW]	135,000 [39.55]	80,000 [23.44]	100,000 [29.3]	135,000 [39.55]
Heating Output Btu [kW]	109,400 [32.05]	64,800 [18.99]	81,000 [23.73]	109,400 [32.05]
Temperature Rise Range °F [°C]	50-80 [27.8-44.4]	30-60 [16.7-33.3]	40-70 [22.2-38.9]	50-80 [27.8-44.4]
AFUE %	80	80	80	80
Steady State Efficiency (%)	81	81	81	81
No. Burners	6	4	5	6
No. Stages	1	1	1	1
Gas Connection Pipe Size in. [mm]	0.5 [12.7]	0.5 [12.7]	0.5 [12.7]	0.5 [12.7]
Compressor				
No./Type	1/Scroll	1/Scroll	1/Scroll	1/Scroll
Outdoor Sound Rating (dB)⁴	78	78	78	78
Outdoor Coil—Fin Type	Louvered	Louvered	Louvered	Louvered
Tube Type	MicroChannel	MicroChannel	MicroChannel	MicroChannel
MicroChannel Depth in. [mm]	0.7 [18]	0.7 [18]	0.7 [18]	0.7 [18]
Face Area sq. ft. [sq. m]	16.4 [1.52]	16.4 [1.52]	16.4 [1.52]	16.4 [1.52]
Rows / FPI [FPcm]	1 / 23 [9]	1 / 23 [9]	1 / 23 [9]	1 / 23 [9]
Indoor Coil—Fin Type	Louvered	Louvered	Louvered	Louvered
Tube Type	MicroChannel	MicroChannel	MicroChannel	MicroChannel
MicroChannel Depth in. [mm]	1.3 [32]	1.3 [32]	1.3 [32]	1.3 [32]
Face Area sq. ft. [sq. m]	4.8 [0.45]	4.8 [0.45]	4.8 [0.45]	4.8 [0.45]
Rows / FPI [FPcm]	1 / 20 [8]	1 / 20 [8]	1 / 20 [8]	1 / 20 [8]
Refrigerant Control	TX Valves	TX Valves	TX Valves	TX Valves
Drain Connection No./Size in. [mm]	1/0.75 [19.05]	1/0.75 [19.05]	1/0.75 [19.05]	1/0.75 [19.05]
Outdoor Fan—Type	Propeller	Propeller	Propeller	Propeller
No. Used/Diameter in. [mm]	1/24 [609.6]	1/24 [609.6]	1/24 [609.6]	1/24 [609.6]
Drive Type/No. Speeds	Direct/1	Direct/1	Direct/1	Direct/1
CFM [L/s]	3680 [1737]	3680 [1737]	3680 [1737]	3680 [1737]
No. Motors/HP	1 at 1/3 HP	1 at 1/3 HP	1 at 1/3 HP	1 at 1/3 HP
Motor RPM	1075	1075	1075	1075
Indoor Fan—Type	FC Centrifugal	FC Centrifugal	FC Centrifugal	FC Centrifugal
No. Used/Diameter in. [mm]	1/10x10 [254x254]	1/10x10 [254x254]	1/10x10 [254x254]	1/10x10 [254x254]
Drive Type	Direct	Belt (Adjustable)	Belt (Adjustable)	Belt (Adjustable)
No. Speeds	Multiple	Single	Single	Single
No. Motors	1	1	1	1
Motor HP	3/4	1/2	1/2	1/2
Motor RPM	1075	1725	1725	1725
Motor Frame Size	48	48	48	48
Filter—Type	Disposable	Disposable	Disposable	Disposable
Furnished	Yes	Yes	Yes	Yes
(NO.) Size Recommended in. [mm x mm x mm]	(1)1x16x25 [25x406x635] (1)1x16x25 [25x406x635]	(1)1x16x25 [25x406x635] (1)1x16x25 [25x406x635]	(1)1x16x25 [25x406x635] (1)1x16x25 [25x406x635]	(1)1x16x25 [25x406x635] (1)1x16x25 [25x406x635]
Refrigerant Charge Oz. [g]	68 [1928]	68 [1928]	68 [1928]	68 [1928]
Weights				
Net Weight lbs. [kg]	541 [245]	549 [249]	554 [251]	559 [254]
Ship Weight lbs. [kg]	548 [249]	556 [252]	561 [254]	566 [257]

See Page 48 for Notes.

[] Designates Metric Conversions

NOM. SIZES 3-5 TONS [10.6-17.6 kW]

Model RKQN- Series	A048CM08	A048CM10	A048CM13	A048DK08
Cooling Performance¹				CONTINUED →
Gross Cooling Capacity Btu [kW]	48,000 [14.06]	48,000 [14.06]	48,000 [14.06]	48,000 [14.06]
EER/SEER ²	12.5/15	12.5/15	12.5/15	12.5/15
Nominal CFM/AHRI Rated CFM [L/s]	1600/1600 [755/755]	1600/1600 [755/755]	1600/1600 [755/755]	1600/1600 [755/755]
AHRI Net Cooling Capacity Btu [kW]	46,500 [13.62]	46,500 [13.62]	46,500 [13.62]	46,500 [13.62]
Net Sensible Capacity Btu [kW]	35,700 [10.46]	35,700 [10.46]	35,700 [10.46]	35,700 [10.46]
Net Latent Capacity Btu [kW]	10,800 [3.16]	10,800 [3.16]	10,800 [3.16]	10,800 [3.16]
Net System Power kW	3.69	3.69	3.69	3.69
Heating Performance (Gas)³				
Heating Input Btu [kW]	80,000 [23.44]	100,000 [29.3]	135,000 [39.55]	80,000 [23.44]
Heating Output Btu [kW]	64,800 [18.99]	81,000 [23.73]	109,400 [32.05]	64,800 [18.99]
Temperature Rise Range °F [°C]	30-60 [16.7-33.3]	40-70 [22.2-38.9]	50-80 [27.8-44.4]	30-60 [16.7-33.3]
AFUE %	80	80	80	80
Steady State Efficiency (%)	81	81	81	81
No. Burners	4	5	6	4
No. Stages	1	1	1	1
Gas Connection Pipe Size in. [mm]	0.5 [12.7]	0.5 [12.7]	0.5 [12.7]	0.5 [12.7]
Compressor				
No./Type	1/Scroll	1/Scroll	1/Scroll	1/Scroll
Outdoor Sound Rating (dB)⁴	78	78	78	78
Outdoor Coil—Fin Type	Louvered	Louvered	Louvered	Louvered
Tube Type	MicroChannel	MicroChannel	MicroChannel	MicroChannel
MicroChannel Depth in. [mm]	0.7 [18]	0.7 [18]	0.7 [18]	0.7 [18]
Face Area sq. ft. [sq. m]	16.4 [1.52]	16.4 [1.52]	16.4 [1.52]	16.4 [1.52]
Rows / FPI [FPcm]	1 / 23 [9]	1 / 23 [9]	1 / 23 [9]	1 / 23 [9]
Indoor Coil—Fin Type	Louvered	Louvered	Louvered	Louvered
Tube Type	MicroChannel	MicroChannel	MicroChannel	MicroChannel
MicroChannel Depth in. [mm]	1.3 [32]	1.3 [32]	1.3 [32]	1.3 [32]
Face Area sq. ft. [sq. m]	4.8 [0.45]	4.8 [0.45]	4.8 [0.45]	4.8 [0.45]
Rows / FPI [FPcm]	1 / 20 [8]	1 / 20 [8]	1 / 20 [8]	1 / 20 [8]
Refrigerant Control	TX Valves	TX Valves	TX Valves	TX Valves
Drain Connection No./Size in. [mm]	1/0.75 [19.05]	1/0.75 [19.05]	1/0.75 [19.05]	1/0.75 [19.05]
Outdoor Fan—Type	Propeller	Propeller	Propeller	Propeller
No. Used/Diameter in. [mm]	1/24 [609.6]	1/24 [609.6]	1/24 [609.6]	1/24 [609.6]
Drive Type/No. Speeds	Direct/1	Direct/1	Direct/1	Direct/1
CFM [L/s]	3680 [1737]	3680 [1737]	3680 [1737]	3680 [1737]
No. Motors/HP	1 at 1/3 HP	1 at 1/3 HP	1 at 1/3 HP	1 at 1/3 HP
Motor RPM	1075	1075	1075	1075
Indoor Fan—Type	FC Centrifugal	FC Centrifugal	FC Centrifugal	FC Centrifugal
No. Used/Diameter in. [mm]	1/10x10 [254x254]	1/10x10 [254x254]	1/10x10 [254x254]	1/10x10 [254x254]
Drive Type	Belt (Adjustable)	Belt (Adjustable)	Belt (Adjustable)	Direct
No. Speeds	Single	Single	Single	Multiple
No. Motors	1	1	1	1
Motor HP	3/4	3/4	3/4	3/4
Motor RPM	1725	1725	1725	1075
Motor Frame Size	56	56	56	48
Filter—Type	Disposable	Disposable	Disposable	Disposable
Furnished	Yes	Yes	Yes	Yes
(NO.) Size Recommended in. [mm x mm x mm]	(1)1x16x25 [25x406x635]	(1)1x16x25 [25x406x635]	(1)1x16x25 [25x406x635]	(1)1x16x25 [25x406x635]
	(1)1x16x25 [25x406x635]	(1)1x16x25 [25x406x635]	(1)1x16x25 [25x406x635]	(1)1x16x25 [25x406x635]
Refrigerant Charge Oz. [g]	68 [1928]	68 [1928]	68 [1928]	68 [1928]
Weights				
Net Weight lbs. [kg]	550 [249]	555 [252]	560 [254]	531 [241]
Ship Weight lbs. [kg]	557 [253]	562 [255]	567 [257]	538 [244]

See Page 48 for Notes.

[] Designates Metric Conversions

NOM. SIZES 3-5 TONS [10.6-17.6 kW]

Model RKQN- Series	A048DK10	A048DK13	A048DL08	A048DL10
Cooling Performance¹				CONTINUED →
Gross Cooling Capacity Btu [kW]	48,000 [14.06]	48,000 [14.06]	48,000 [14.06]	48,000 [14.06]
EER/SEER ²	12.5/15	12.5/15	12.5/15	12.5/15
Nominal CFM/AHRI Rated CFM [L/s]	1600/1600 [755/755]	1600/1600 [755/755]	1600/1600 [755/755]	1600/1600 [755/755]
AHRI Net Cooling Capacity Btu [kW]	46,500 [13.62]	46,500 [13.62]	46,500 [13.62]	46,500 [13.62]
Net Sensible Capacity Btu [kW]	35,700 [10.46]	35,700 [10.46]	35,700 [10.46]	35,700 [10.46]
Net Latent Capacity Btu [kW]	10,800 [3.16]	10,800 [3.16]	10,800 [3.16]	10,800 [3.16]
Net System Power kW	3.69	3.69	3.69	3.69
Heating Performance (Gas)³				
Heating Input Btu [kW]	100,000 [29.3]	135,000 [39.55]	80,000 [23.44]	100,000 [29.3]
Heating Output Btu [kW]	81,000 [23.73]	109,400 [32.05]	64,800 [18.99]	81,000 [23.73]
Temperature Rise Range °F [°C]	40-70 [22.2-38.9]	50-80 [27.8-44.4]	30-60 [16.7-33.3]	40-70 [22.2-38.9]
AFUE %	80	80	80	80
Steady State Efficiency (%)	81	81	81	81
No. Burners	5	6	4	5
No. Stages	1	1	1	1
Gas Connection Pipe Size in. [mm]	0.5 [12.7]	0.5 [12.7]	0.5 [12.7]	0.5 [12.7]
Compressor				
No./Type	1/Scroll	1/Scroll	1/Scroll	1/Scroll
Outdoor Sound Rating (dB)⁴	78	78	78	78
Outdoor Coil—Fin Type	Louvered	Louvered	Louvered	Louvered
Tube Type	MicroChannel	MicroChannel	MicroChannel	MicroChannel
MicroChannel Depth in. [mm]	0.7 [18]	0.7 [18]	0.7 [18]	0.7 [18]
Face Area sq. ft. [sq. m]	16.4 [1.52]	16.4 [1.52]	16.4 [1.52]	16.4 [1.52]
Rows / FPI [FPcm]	1 / 23 [9]	1 / 23 [9]	1 / 23 [9]	1 / 23 [9]
Indoor Coil—Fin Type	Louvered	Louvered	Louvered	Louvered
Tube Type	MicroChannel	MicroChannel	MicroChannel	MicroChannel
MicroChannel Depth in. [mm]	1.3 [32]	1.3 [32]	1.3 [32]	1.3 [32]
Face Area sq. ft. [sq. m]	4.8 [0.45]	4.8 [0.45]	4.8 [0.45]	4.8 [0.45]
Rows / FPI [FPcm]	1 / 20 [8]	1 / 20 [8]	1 / 20 [8]	1 / 20 [8]
Refrigerant Control	TX Valves	TX Valves	TX Valves	TX Valves
Drain Connection No./Size in. [mm]	1/0.75 [19.05]	1/0.75 [19.05]	1/0.75 [19.05]	1/0.75 [19.05]
Outdoor Fan—Type	Propeller	Propeller	Propeller	Propeller
No. Used/Diameter in. [mm]	1/24 [609.6]	1/24 [609.6]	1/24 [609.6]	1/24 [609.6]
Drive Type/No. Speeds	Direct/1	Direct/1	Direct/1	Direct/1
CFM [L/s]	3680 [1737]	3680 [1737]	3680 [1737]	3680 [1737]
No. Motors/HP	1 at 1/3 HP	1 at 1/3 HP	1 at 1/3 HP	1 at 1/3 HP
Motor RPM	1075	1075	1075	1075
Indoor Fan—Type	FC Centrifugal	FC Centrifugal	FC Centrifugal	FC Centrifugal
No. Used/Diameter in. [mm]	1/10x10 [254x254]	1/10x10 [254x254]	1/10x10 [254x254]	1/10x10 [254x254]
Drive Type	Direct	Direct	Belt (Adjustable)	Belt (Adjustable)
No. Speeds	Multiple	Multiple	Single	Single
No. Motors	1	1	1	1
Motor HP	3/4	3/4	1/2	1/2
Motor RPM	1075	1075	1725	1725
Motor Frame Size	48	48	48	48
Filter—Type	Disposable	Disposable	Disposable	Disposable
Furnished	Yes	Yes	Yes	Yes
(NO.) Size Recommended in. [mm x mm x mm]	(1)1x16x25 [25x406x635] (1)1x16x25 [25x406x635]	(1)1x16x25 [25x406x635] (1)1x16x25 [25x406x635]	(1)1x16x25 [25x406x635] (1)1x16x25 [25x406x635]	(1)1x16x25 [25x406x635] (1)1x16x25 [25x406x635]
Refrigerant Charge Oz. [g]	68 [1928]	68 [1928]	68 [1928]	68 [1928]
Weights				
Net Weight lbs. [kg]	536 [243]	541 [245]	549 [249]	554 [251]
Ship Weight lbs. [kg]	543 [246]	548 [249]	556 [252]	561 [254]

See Page 48 for Notes.

[] Designates Metric Conversions

NOM. SIZES 3-5 TONS [10.6-17.6 kW]

Model RKQN- Series	A048DL13	A048DM08	A048DM10	A048DM13
Cooling Performance¹				CONTINUED →
Gross Cooling Capacity Btu [kW]	48,000 [14.06]	48,000 [14.06]	48,000 [14.06]	48,000 [14.06]
EER/SEER ²	12.5/15	12.5/15	12.5/15	12.5/15
Nominal CFM/AHRI Rated CFM [L/s]	1600/1600 [755/755]	1600/1600 [755/755]	1600/1600 [755/755]	1600/1600 [755/755]
AHRI Net Cooling Capacity Btu [kW]	46,500 [13.62]	46,500 [13.62]	46,500 [13.62]	46,500 [13.62]
Net Sensible Capacity Btu [kW]	35,700 [10.46]	35,700 [10.46]	35,700 [10.46]	35,700 [10.46]
Net Latent Capacity Btu [kW]	10,800 [3.16]	10,800 [3.16]	10,800 [3.16]	10,800 [3.16]
Net System Power kW	3.69	3.69	3.69	3.69
Heating Performance (Gas)³				
Heating Input Btu [kW]	135,000 [39.55]	80,000 [23.44]	100,000 [29.3]	135,000 [39.55]
Heating Output Btu [kW]	109,400 [32.05]	64,800 [18.99]	81,000 [23.73]	109,400 [32.05]
Temperature Rise Range °F [°C]	50-80 [27.8-44.4]	30-60 [16.7-33.3]	40-70 [22.2-38.9]	50-80 [27.8-44.4]
AFUE %	80	80	80	80
Steady State Efficiency (%)	81	81	81	81
No. Burners	6	4	5	6
No. Stages	1	1	1	1
Gas Connection Pipe Size in. [mm]	0.5 [12.7]	0.5 [12.7]	0.5 [12.7]	0.5 [12.7]
Compressor				
No./Type	1/Scroll	1/Scroll	1/Scroll	1/Scroll
Outdoor Sound Rating (dB)⁴	78	78	78	78
Outdoor Coil—Fin Type	Louvered	Louvered	Louvered	Louvered
Tube Type	MicroChannel	MicroChannel	MicroChannel	MicroChannel
MicroChannel Depth in. [mm]	0.7 [18]	0.7 [18]	0.7 [18]	0.7 [18]
Face Area sq. ft. [sq. m]	16.4 [1.52]	16.4 [1.52]	16.4 [1.52]	16.4 [1.52]
Rows / FPI [FPcm]	1 / 23 [9]	1 / 23 [9]	1 / 23 [9]	1 / 23 [9]
Indoor Coil—Fin Type	Louvered	Louvered	Louvered	Louvered
Tube Type	MicroChannel	MicroChannel	MicroChannel	MicroChannel
MicroChannel Depth in. [mm]	1.3 [32]	1.3 [32]	1.3 [32]	1.3 [32]
Face Area sq. ft. [sq. m]	4.8 [0.45]	4.8 [0.45]	4.8 [0.45]	4.8 [0.45]
Rows / FPI [FPcm]	1 / 20 [8]	1 / 20 [8]	1 / 20 [8]	1 / 20 [8]
Refrigerant Control	TX Valves	TX Valves	TX Valves	TX Valves
Drain Connection No./Size in. [mm]	1/0.75 [19.05]	1/0.75 [19.05]	1/0.75 [19.05]	1/0.75 [19.05]
Outdoor Fan—Type	Propeller	Propeller	Propeller	Propeller
No. Used/Diameter in. [mm]	1/24 [609.6]	1/24 [609.6]	1/24 [609.6]	1/24 [609.6]
Drive Type/No. Speeds	Direct/1	Direct/1	Direct/1	Direct/1
CFM [L/s]	3680 [1737]	3680 [1737]	3680 [1737]	3680 [1737]
No. Motors/HP	1 at 1/3 HP	1 at 1/3 HP	1 at 1/3 HP	1 at 1/3 HP
Motor RPM	1075	1075	1075	1075
Indoor Fan—Type	FC Centrifugal	FC Centrifugal	FC Centrifugal	FC Centrifugal
No. Used/Diameter in. [mm]	1/10x10 [254x254]	1/10x10 [254x254]	1/10x10 [254x254]	1/10x10 [254x254]
Drive Type	Belt (Adjustable)	Belt (Adjustable)	Belt (Adjustable)	Belt (Adjustable)
No. Speeds	Single	Single	Single	Single
No. Motors	1	1	1	1
Motor HP	1/2	3/4	3/4	3/4
Motor RPM	1725	1725	1725	1725
Motor Frame Size	48	56	56	56
Filter—Type	Disposable	Disposable	Disposable	Disposable
Furnished	Yes	Yes	Yes	Yes
(NO.) Size Recommended in. [mm x mm x mm]	(1)1x16x25 [25x406x635]	(1)1x16x25 [25x406x635]	(1)1x16x25 [25x406x635]	(1)1x16x25 [25x406x635]
	(1)1x16x25 [25x406x635]	(1)1x16x25 [25x406x635]	(1)1x16x25 [25x406x635]	(1)1x16x25 [25x406x635]
Refrigerant Charge Oz. [g]	68 [1928]	68 [1928]	68 [1928]	68 [1928]
Weights				
Net Weight lbs. [kg]	559 [254]	550 [249]	555 [252]	560 [254]
Ship Weight lbs. [kg]	566 [257]	557 [253]	562 [255]	567 [257]

See Page 48 for Notes.

[] Designates Metric Conversions

NOM. SIZES 3-5 TONS [10.6-17.6 kW]

Model RKQN- Series	A048JK08	A048JK10	A048JK13
Cooling Performance¹			
Gross Cooling Capacity Btu [kW]	48,000 [14.06]	48,000 [14.06]	48,000 [14.06]
EER/SEER ²	12.5/15	12.5/15	12.5/15
Nominal CFM/AHRI Rated CFM [L/s]	1600/1600 [755/755]	1600/1600 [755/755]	1600/1600 [755/755]
AHRI Net Cooling Capacity Btu [kW]	46,500 [13.62]	46,500 [13.62]	46,500 [13.62]
Net Sensible Capacity Btu [kW]	35,700 [10.46]	35,700 [10.46]	35,700 [10.46]
Net Latent Capacity Btu [kW]	10,800 [3.16]	10,800 [3.16]	10,800 [3.16]
Net System Power kW	3.69	3.69	3.69
Heating Performance (Gas)³			
Heating Input Btu [kW]	80,000 [23.44]	100,000 [29.3]	135,000 [39.55]
Heating Output Btu [kW]	64,000 [18.76]	80,000 [23.44]	108,000 [31.65]
Temperature Rise Range °F [°C]	30-60 [16.7-33.3]	40-70 [22.2-38.9]	50-80 [27.8-44.4]
AFUE %	80	80	80
Steady State Efficiency (%)	80	80	80
No. Burners	4	5	6
No. Stages	1	1	1
Gas Connection Pipe Size in. [mm]	0.5 [12.7]	0.5 [12.7]	0.5 [12.7]
Compressor			
No./Type	1/Scroll	1/Scroll	1/Scroll
Outdoor Sound Rating (dB)⁴			
	78	78	78
Outdoor Coil—Fin Type			
Tube Type	Louvered	Louvered	Louvered
MicroChannel Depth in. [mm]	MicroChannel	MicroChannel	MicroChannel
Face Area sq. ft. [sq. m]	0.7 [18]	0.7 [18]	0.7 [18]
Rows / FPI [FPcm]	16.4 [1.52]	16.4 [1.52]	16.4 [1.52]
	1 / 23 [9]	1 / 23 [9]	1 / 23 [9]
Indoor Coil—Fin Type			
Tube Type	Louvered	Louvered	Louvered
MicroChannel Depth in. [mm]	MicroChannel	MicroChannel	MicroChannel
Face Area sq. ft. [sq. m]	1.3 [32]	1.3 [32]	1.3 [32]
Rows / FPI [FPcm]	4.8 [0.45]	4.8 [0.45]	4.8 [0.45]
	1 / 20 [8]	1 / 20 [8]	1 / 20 [8]
Refrigerant Control	TX Valves	TX Valves	TX Valves
Drain Connection No./Size in. [mm]	1/0.75 [19.05]	1/0.75 [19.05]	1/0.75 [19.05]
Outdoor Fan—Type			
No. Used/Diameter in. [mm]	Propeller	Propeller	Propeller
Drive Type/No. Speeds	1/24 [609.6]	1/24 [609.6]	1/24 [609.6]
CFM [L/s]	Direct/1	Direct/1	Direct/1
No. Motors/HP	3680 [1737]	3680 [1737]	3680 [1737]
Motor RPM	1 at 1/3 HP	1 at 1/3 HP	1 at 1/3 HP
	1075	1075	1075
Indoor Fan—Type			
No. Used/Diameter in. [mm]	FC Centrifugal	FC Centrifugal	FC Centrifugal
Drive Type	1/10x10 [254x254]	1/10x10 [254x254]	1/10x10 [254x254]
No. Speeds	Direct	Direct	Direct
No. Motors	Multiple	Multiple	Multiple
Motor HP	1	1	1
Motor RPM	3/4	3/4	3/4
Motor Frame Size	1075	1075	1075
	48	48	48
Filter—Type			
Furnished	Disposable	Disposable	Disposable
(NO.) Size Recommended in. [mm x mm x mm]	Yes	Yes	Yes
	(1)1x16x25 [25x406x635]	(1)1x16x25 [25x406x635]	(1)1x16x25 [25x406x635]
	(1)1x16x25 [25x406x635]	(1)1x16x25 [25x406x635]	(1)1x16x25 [25x406x635]
Refrigerant Charge Oz. [g]			
	68 [1928]	68 [1928]	68 [1928]
Weights			
Net Weight lbs. [kg]	531 [241]	536 [243]	541 [245]
Ship Weight lbs. [kg]	538 [244]	543 [246]	548 [249]

CONTINUED →

See Page 48 for Notes.

[] Designates Metric Conversions

NOM. SIZES 3-5 TONS [10.6-17.6 kW]

Model RKQN- Series	A060CK10	A060CK13	A060CV10	A060CV13
Cooling Performance¹				CONTINUED →
Gross Cooling Capacity Btu [kW]	59,000 [17.29]	59,000 [17.29]	59,000 [17.29]	59,000 [17.29]
SEER ²	15	15	15	15
EER (1st stage / 2nd stage)	19.9/11.6	19.9/11.6	19.9/11.6	19.9/11.6
AHRI Rated CFM (1st / 2nd stage) [L/s]	1375 / 1800 [649 / 849]	1375 / 1800 [649 / 849]	1375 / 1800 [649 / 849]	1375 / 1800 [649 / 849]
AHRI Net Cooling Capacity (1st / 2nd stage) Btu [kW]	49,000 / 57,000 [14.3/16.7]	49,000 / 57,000 [14.3/16.7]	49,000 / 57,000 [14.3/16.7]	49,000 / 57,000 [14.3/16.7]
Net Sensible Capacity (1st / 2nd stage) Btu [kW]	34,800 / 40,800 [10.2/12.0]	34,800 / 40,800 [10.2/12.0]	34,800 / 40,800 [10.2/12.0]	34,800 / 40,800 [10.2/12.0]
Net Latent Capacity (1st / 2nd stage) Btu [kW]	14,200 / 16,200 [4.2 / 4.8]	14,200 / 16,200 [4.2 / 4.8]	14,200 / 16,200 [4.2 / 4.8]	14,200 / 16,200 [4.2 / 4.8]
Net System Power (1st / 2nd stage) [kW]	2.1 / 4.8	2.1 / 4.8	2.1 / 4.8	2.1 / 4.8
Heating Performance (Gas)³				
Heating Input Btu [kW]	100,000 [29.3]	135,000 [39.55]	100,000 [29.3]	135,000 [39.55]
Heating Output Btu [kW]	81,000 [23.73]	109,400 [32.05]	81,000 [23.73]	109,400 [32.05]
Temperature Rise Range °F [°C]	25-55 [13.9-30.6]	40-70 [22.2-38.9]	25-55 [13.9-30.6]	40-70 [22.2-38.9]
AFUE %	80	80	80	80
Steady State Efficiency (%)	81	81	81	81
No. Burners	5	6	5	6
No. Stages	1	1	1	1
Gas Connection Pipe Size in. [mm]	0.5 [12.7]	0.5 [12.7]	0.5 [12.7]	0.5 [12.7]
Compressor				
No./Type	1/Scroll	1/Scroll	1/Scroll	1/Scroll
Outdoor Sound Rating (dB)⁴	83	83	83	83
Outdoor Coil—Fin Type	Louvered	Louvered	Louvered	Louvered
Tube Type	MicroChannel	MicroChannel	MicroChannel	MicroChannel
MicroChannel Depth in. [mm]	0.7 [18]	0.7 [18]	0.7 [18]	0.7 [18]
Face Area sq. ft. [sq. m]	16.4 [1.52]	16.4 [1.52]	16.4 [1.52]	16.4 [1.52]
Rows / FPI [FPcm]	1 / 23 [9]	1 / 23 [9]	1 / 23 [9]	1 / 23 [9]
Indoor Coil—Fin Type	Louvered	Louvered	Louvered	Louvered
Tube Type	MicroChannel	MicroChannel	MicroChannel	MicroChannel
MicroChannel Depth in. [mm]	1.3 [32]	1.3 [32]	1.3 [32]	1.3 [32]
Face Area sq. ft. [sq. m]	4.8 [0.45]	4.8 [0.45]	4.8 [0.45]	4.8 [0.45]
Rows / FPI [FPcm]	1 / 20 [8]	1 / 20 [8]	1 / 20 [8]	1 / 20 [8]
Refrigerant Control	TX Valves	TX Valves	TX Valves	TX Valves
Drain Connection No./Size in. [mm]	1/0.75 [19.05]	1/0.75 [19.05]	1/0.75 [19.05]	1/0.75 [19.05]
Outdoor Fan—Type	Propeller	Propeller	Propeller	Propeller
No. Used/Diameter in. [mm]	1/24 [609.6]	1/24 [609.6]	1/24 [609.6]	1/24 [609.6]
Drive Type/No. Speeds	Direct/1	Direct/1	Direct/1	Direct/1
CFM [L/s]	3930 [1855]	3930 [1855]	3930 [1855]	3930 [1855]
No. Motors/HP	1 at 1/3 HP	1 at 1/3 HP	1 at 1/3 HP	1 at 1/3 HP
Motor RPM	1075	1075	1075	1075
Indoor Fan—Type	FC Centrifugal	FC Centrifugal	FC Centrifugal	FC Centrifugal
No. Used/Diameter in. [mm]	1/10x10 [254x254]	1/10x10 [254x254]	1/11x10 [279x254]	1/11x10 [279x254]
Drive Type	Direct	Direct	Direct	Direct
No. Speeds	Multiple	Multiple	Variable	Variable
No. Motors	1	1	1	1
Motor HP	1	1	1	1
Motor RPM	1075	1075	1075	1075
Motor Frame Size	48	48	48	48
Filter—Type	Disposable	Disposable	Disposable	Disposable
Furnished	Yes	Yes	Yes	Yes
(NO.) Size Recommended in. [mm x mm x mm]	(1)1x16x25 [25x406x635] (1)1x16x25 [25x406x635]	(1)1x16x25 [25x406x635] (1)1x16x25 [25x406x635]	(1)1x16x25 [25x406x635] (1)1x16x25 [25x406x635]	(1)1x16x25 [25x406x635] (1)1x16x25 [25x406x635]
Refrigerant Charge Oz. [g]	63 [1786]	63 [1786]	63 [1786]	63 [1786]
Weights				
Net Weight lbs. [kg]	546 [248]	553 [251]	546 [248]	553 [251]
Ship Weight lbs. [kg]	553 [251]	560 [254]	553 [251]	560 [254]

See Page 48 for Notes.

[] Designates Metric Conversions



NOM. SIZES 3-5 TONS [10.6-17.6 kW]

Model RKQN- Series	A060DK10	A060DK13	A060DV10	A060DV13
Cooling Performance¹				
CONTINUED →				
Gross Cooling Capacity Btu [kW]	59,000 [17.29]	59,000 [17.29]	59,000 [17.29]	59,000 [17.29]
SEER ²	15	15	15	15
EER (1st stage / 2nd stage)	19.9/11.6	19.9/11.6	19.9/11.6	19.9/11.6
AHRI Rated CFM (1st / 2nd stage) [L/s]	1375 / 1800 [649 / 849]	1375 / 1800 [649 / 849]	1375 / 1800 [649 / 849]	1375 / 1800 [649 / 849]
AHRI Net Cooling Capacity (1st / 2nd stage) Btu [kW]	49,000 / 57,000 [14.3/16.7]	49,000 / 57,000 [14.3/16.7]	49,000 / 57,000 [14.3/16.7]	49,000 / 57,000 [14.3/16.7]
Net Sensible Capacity (1st / 2nd stage) Btu [kW]	34,800 / 40,800 [10.2/12.0]	34,800 / 40,800 [10.2/12.0]	34,800 / 40,800 [10.2/12.0]	34,800 / 40,800 [10.2/12.0]
Net Latent Capacity (1st / 2nd stage) Btu [kW]	14,200 / 16,200 [4.2 / 4.8]	14,200 / 16,200 [4.2 / 4.8]	14,200 / 16,200 [4.2 / 4.8]	14,200 / 16,200 [4.2 / 4.8]
Net System Power (1st / 2nd stage) [kW]	2.1 / 4.8	2.1 / 4.8	2.1 / 4.8	2.1 / 4.8
Heating Performance (Gas)³				
Heating Input Btu [kW]	100,000 [29.3]	135,000 [39.55]	100,000 [29.3]	135,000 [39.55]
Heating Output Btu [kW]	81,000 [23.73]	109,400 [32.05]	81,000 [23.73]	109,400 [32.05]
Temperature Rise Range °F [°C]	25-55 [13.9-30.6]	40-70 [22.2-38.9]	25-55 [13.9-30.6]	40-70 [22.2-38.9]
AFUE %	80	80	80	80
Steady State Efficiency (%)	81	81	81	81
No. Burners	5	6	5	6
No. Stages	1	1	1	1
Gas Connection Pipe Size in. [mm]	0.5 [12.7]	0.5 [12.7]	0.5 [12.7]	0.5 [12.7]
Compressor				
No./Type	1/Scroll	1/Scroll	1/Scroll	1/Scroll
Outdoor Sound Rating (dB)⁴				
	83	83	83	83
Outdoor Coil—Fin Type				
Tube Type	Louvered	Louvered	Louvered	Louvered
MicroChannel Depth in. [mm]	MicroChannel	MicroChannel	MicroChannel	MicroChannel
Face Area sq. ft. [sq. m]	0.7 [18]	0.7 [18]	0.7 [18]	0.7 [18]
Rows / FPI [FPcm]	16.4 [1.52]	16.4 [1.52]	16.4 [1.52]	16.4 [1.52]
	1 / 23 [9]	1 / 23 [9]	1 / 23 [9]	1 / 23 [9]
Indoor Coil—Fin Type				
Tube Type	Louvered	Louvered	Louvered	Louvered
MicroChannel Depth in. [mm]	MicroChannel	MicroChannel	MicroChannel	MicroChannel
Face Area sq. ft. [sq. m]	1.3 [32]	1.3 [32]	1.3 [32]	1.3 [32]
Rows / FPI [FPcm]	4.8 [0.45]	4.8 [0.45]	4.8 [0.45]	4.8 [0.45]
	1 / 20 [8]	1 / 20 [8]	1 / 20 [8]	1 / 20 [8]
Refrigerant Control	TX Valves	TX Valves	TX Valves	TX Valves
Drain Connection No./Size in. [mm]	1/0.75 [19.05]	1/0.75 [19.05]	1/0.75 [19.05]	1/0.75 [19.05]
Outdoor Fan—Type				
No. Used/Diameter in. [mm]	Propeller	Propeller	Propeller	Propeller
Drive Type/No. Speeds	1/24 [609.6]	1/24 [609.6]	1/24 [609.6]	1/24 [609.6]
CFM [L/s]	Direct/1	Direct/1	Direct/1	Direct/1
No. Motors/HP	3930 [1855]	3930 [1855]	3930 [1855]	3930 [1855]
Motor RPM	1 at 1/3 HP	1 at 1/3 HP	1 at 1/3 HP	1 at 1/3 HP
	1075	1075	1075	1075
Indoor Fan—Type				
No. Used/Diameter in. [mm]	FC Centrifugal	FC Centrifugal	FC Centrifugal	FC Centrifugal
Drive Type	1/10x10 [254x254]	1/10x10 [254x254]	1/11x10 [279x254]	1/11x10 [279x254]
No. Speeds	Direct	Direct	Direct	Direct
No. Motors	Multiple	Multiple	Variable	Variable
Motor HP	1	1	1	1
Motor RPM	1	1	1	1
Motor Frame Size	1075	1075	1075	1075
	48	48	48	48
Filter—Type				
Furnished	Disposable	Disposable	Disposable	Disposable
(NO.) Size Recommended in. [mm x mm x mm]	Yes	Yes	Yes	Yes
	(1)1x16x25 [25x406x635]	(1)1x16x25 [25x406x635]	(1)1x16x25 [25x406x635]	(1)1x16x25 [25x406x635]
	(1)1x16x25 [25x406x635]	(1)1x16x25 [25x406x635]	(1)1x16x25 [25x406x635]	(1)1x16x25 [25x406x635]
Refrigerant Charge Oz. [g]				
	63 [1786]	63 [1786]	63 [1786]	63 [1786]
Weights				
Net Weight lbs. [kg]	546 [248]	553 [251]	602 [273]	609 [276]
Ship Weight lbs. [kg]	553 [251]	560 [254]	609 [276]	616 [279]

See Page 48 for Notes.

[] Designates Metric Conversions

NOM. SIZES 3-5 TONS [10.6-17.6 kW]

Model RKQN- Series	A060JK10	A060JK13
Cooling Performance¹		
Gross Cooling Capacity Btu [kW]	59,000 [17.29]	59,000 [17.29]
SEER ²	15	15
EER (1st stage / 2nd stage)	19.9/11.6	19.9/11.6
AHRI Rated CFM (1st / 2nd stage) [L/s]	1375 / 1800 [649 / 849]	1375 / 1800 [649 / 849]
AHRI Net Cooling Capacity (1st / 2nd stage) Btu [kW]	49,000 / 57,000 [14.3/16.7]	49,000 / 57,000 [14.3/16.7]
Net Sensible Capacity (1st / 2nd stage) Btu [kW]	34,800 / 40,800 [10.2/12.0]	34,800 / 40,800 [10.2/12.0]
Net Latent Capacity (1st / 2nd stage) Btu [kW]	14,200 / 16,200 [4.2 / 4.8]	14,200 / 16,200 [4.2 / 4.8]
Net System Power (1st / 2nd stage) [kW]	2.1 / 4.8	2.1 / 4.8
Heating Performance (Gas)³		
Heating Input Btu [kW]	100,000 [29.3]	135,000 [39.55]
Heating Output Btu [kW]	78,000 [22.85]	106,000 [31.06]
Temperature Rise Range °F [°C]	25-55 [13.9-30.6]	40-70 [22.2-38.9]
AFUE %	80	80
Steady State Efficiency (%)	81	81
No. Burners	5	6
No. Stages	1	1
Gas Connection Pipe Size in. [mm]	0.5 [12.7]	0.5 [12.7]
Compressor		
No./Type	1/Scroll	1/Scroll
Outdoor Sound Rating (dB)⁴		
	83	83
Outdoor Coil—Fin Type		
	Louvered	Louvered
Tube Type	MicroChannel	MicroChannel
MicroChannel Depth in. [mm]	0.7 [18]	0.7 [18]
Face Area sq. ft. [sq. m]	16.4 [1.52]	16.4 [1.52]
Rows / FPI [FPcm]	1 / 23 [9]	1 / 23 [9]
Indoor Coil—Fin Type		
	Louvered	Louvered
Tube Type	MicroChannel	MicroChannel
MicroChannel Depth in. [mm]	1.3 [32]	1.3 [32]
Face Area sq. ft. [sq. m]	4.8 [0.45]	4.8 [0.45]
Rows / FPI [FPcm]	1 / 20 [8]	1 / 20 [8]
Refrigerant Control	TX Valves	TX Valves
Drain Connection No./Size in. [mm]	1/0.75 [19.05]	1/0.75 [19.05]
Outdoor Fan—Type		
	Propeller	Propeller
No. Used/Diameter in. [mm]	1/24 [609.6]	1/24 [609.6]
Drive Type/No. Speeds	Direct/1	Direct/1
CFM [L/s]	3930 [1855]	3930 [1855]
No. Motors/HP	1 at 1/3 HP	1 at 1/3 HP
Motor RPM	1075	1075
Indoor Fan—Type		
	FC Centrifugal	FC Centrifugal
No. Used/Diameter in. [mm]	1/10x10 [254x254]	1/10x10 [254x254]
Drive Type	Direct	Direct
No. Speeds	Multiple	Multiple
No. Motors	1	1
Motor HP	1	1
Motor RPM	1075	1075
Motor Frame Size	48	48
Filter—Type		
	Disposable	Disposable
Furnished	Yes	Yes
(NO.) Size Recommended in. [mm x mm x mm]	(1)1x16x25 [25x406x635]	(1)1x16x25 [25x406x635]
	(1)1x16x25 [25x406x635]	(1)1x16x25 [25x406x635]
Refrigerant Charge Oz. [g]		
	63 [1786]	63 [1786]
Weights		
Net Weight lbs. [kg]	546 [248]	553 [251]
Ship Weight lbs. [kg]	553 [251]	560 [254]

See Page 48 for Notes.

[] Designates Metric Conversions





NOTES:

1. Cooling Performance is rated at 95° F ambient, 80° F entering dry bulb, 67° F entering wet bulb. Gross capacity does not include the effect of fan motor heat. AHRI capacity is net and includes the effect of fan motor heat. Units are suitable for operation to $\pm 20\%$ of nominal cfm. Units are certified in accordance with the Unitary Air Conditioner Equipment certification program, which is based on AHRI Standard 210/240 or 360.
2. EER and/or SEER are rated at AHRI conditions and in accordance with DOE test procedures.
3. Heating Performance limit settings and rating data were established and approved under laboratory test conditions using American National Standard Institute standards. Ratings shown are for elevations up to 2000 feet. For elevations above 2000 feet, ratings should be reduced at the rate of 4% for each 1000 feet above sea level.
4. Outdoor Sound Rating shown is tested in accordance with AHRI Standard 270.

GROSS SYSTEMS PERFORMANCE DATA—RKNN-A036

ENTERING INDOOR AIR @ 80°F [26.7°C] dbE ①											
wbE		71°F [21.7°C]			67°F [19.4°C]			63°F [17.2°C]			
CFM [L/s]		1375 [649]	1250 [590]	1062 [501]	1375 [649]	1250 [590]	1062 [501]	1375 [649]	1250 [590]	1062 [501]	
DR ①		0.2	0.18	0.15	0.2	0.18	0.15	0.2	0.18	0.15	
OUTDOOR DRY BULB TEMPERATURE °F [°C]	75 [23.9]	Total BTUH [kW]	45.0 [13.2]	44.2 [13.0]	43.0 [12.6]	42.3 [12.4]	41.6 [12.2]	40.4 [11.8]	39.9 [11.7]	39.2 [11.5]	38.1 [11.2]
		Sens BTUH [kW]	26.6 [7.8]	25.4 [7.4]	23.6 [6.9]	31.0 [9.1]	29.6 [8.7]	27.6 [8.1]	34.8 [10.2]	33.2 [9.7]	30.9 [9.0]
		Power	2.0	2.0	1.9	2.0	1.9	1.9	1.9	1.9	1.9
	80 [26.7]	Total BTUH [kW]	43.7 [12.8]	42.9 [12.6]	41.7 [12.2]	41.0 [12.0]	40.2 [11.8]	39.1 [11.5]	38.5 [11.3]	37.8 [11.1]	36.8 [10.8]
		Sens BTUH [kW]	25.9 [7.6]	24.8 [7.3]	23.0 [6.7]	30.4 [8.9]	29.0 [8.5]	27.0 [7.9]	34.1 [10.0]	32.6 [9.5]	30.3 [8.9]
		Power	2.1	2.1	2.1	2.1	2.1	2.0	2.1	2.0	2.0
	85 [29.4]	Total BTUH [kW]	42.3 [12.4]	41.6 [12.2]	40.4 [11.8]	39.6 [11.6]	38.9 [11.4]	37.8 [11.1]	37.2 [10.9]	36.5 [10.7]	35.5 [10.4]
		Sens BTUH [kW]	25.2 [7.4]	24.1 [7.1]	22.4 [6.6]	29.7 [8.7]	28.4 [8.3]	26.4 [7.7]	33.4 [9.8]	31.9 [9.4]	29.7 [8.7]
		Power	2.2	2.2	2.2	2.2	2.2	2.2	2.2	2.2	2.1
	90 [32.2]	Total BTUH [kW]	41.0 [12.0]	40.2 [11.8]	39.1 [11.5]	38.3 [11.2]	37.6 [11.0]	36.5 [10.7]	35.8 [10.5]	35.2 [10.3]	34.2 [10.0]
Sens BTUH [kW]		24.5 [7.2]	23.4 [6.9]	21.8 [6.4]	29.0 [8.5]	27.7 [8.1]	25.7 [7.5]	32.7 [9.6]	31.2 [9.2]	29.0 [8.5]	
Power		2.4	2.3	2.3	2.3	2.3	2.3	2.3	2.3	2.3	
95 [35]	Total BTUH [kW]	39.6 [11.6]	38.9 [11.4]	37.8 [11.1]	36.9 [10.8]	36.2 [10.6]	35.2 [10.3]	34.4 [10.1]	33.8 [9.9]	32.9 [9.6]	
	Sens BTUH [kW]	23.8 [7.0]	22.7 [6.7]	21.1 [6.2]	28.2 [8.3]	26.9 [7.9]	25.0 [7.3]	31.9 [9.4]	30.5 [8.9]	28.4 [8.3]	
	Power	2.5	2.5	2.4	2.5	2.4	2.4	2.4	2.4	2.4	
100 [37.8]	Total BTUH [kW]	38.2 [11.2]	37.6 [11.0]	36.5 [10.7]	35.5 [10.4]	34.9 [10.2]	33.9 [9.9]	33.1 [9.7]	32.5 [9.5]	31.6 [9.3]	
	Sens BTUH [kW]	23.0 [6.7]	21.9 [6.4]	20.4 [6.0]	27.4 [8.0]	26.2 [7.7]	24.3 [7.1]	31.1 [9.1]	29.7 [8.7]	27.7 [8.1]	
	Power	2.6	2.6	2.6	2.6	2.6	2.6	2.6	2.6	2.5	
105 [40.6]	Total BTUH [kW]	36.9 [10.8]	36.2 [10.6]	35.2 [10.3]	34.2 [10.0]	33.6 [9.8]	32.6 [9.6]	31.7 [9.3]	31.2 [9.1]	30.3 [8.9]	
	Sens BTUH [kW]	22.1 [6.5]	21.1 [6.2]	19.7 [5.8]	26.6 [7.8]	25.4 [7.4]	23.6 [6.9]	30.3 [8.9]	29.0 [8.5]	26.9 [7.9]	
	Power	2.8	2.8	2.7	2.8	2.7	2.7	2.7	2.7	2.7	
110 [43.3]	Total BTUH [kW]	35.5 [10.4]	34.9 [10.2]	33.9 [9.9]	32.8 [9.6]	32.2 [9.4]	31.3 [9.2]	30.3 [8.9]	29.8 [8.7]	29.0 [8.5]	
	Sens BTUH [kW]	21.3 [6.2]	20.3 [6.0]	18.9 [5.5]	25.7 [7.5]	24.6 [7.2]	22.8 [6.7]	29.4 [8.6]	28.1 [8.2]	26.1 [7.7]	
	Power	2.9	2.9	2.9	2.9	2.9	2.9	2.9	2.9	2.8	
115 [46.1]	Total BTUH [kW]	34.1 [10.0]	33.5 [9.8]	32.6 [9.6]	31.4 [9.2]	30.9 [9.0]	30.0 [8.8]	29.0 [8.5]	28.5 [8.3]	27.7 [8.1]	
	Sens BTUH [kW]	20.4 [6.0]	19.4 [5.7]	18.1 [5.3]	24.8 [7.3]	23.7 [6.9]	22.0 [6.5]	28.5 [8.4]	27.3 [8.0]	25.3 [7.4]	
	Power	3.1	3.1	3.0	3.1	3.1	3.0	3.1	3.0	3.0	
120 [48.9]	Total BTUH [kW]	32.8 [9.6]	32.2 [9.4]	31.3 [9.2]	30.0 [8.8]	29.5 [8.6]	28.7 [8.4]	27.6 [8.1]	27.1 [7.9]	26.4 [7.7]	
	Sens BTUH [kW]	19.4 [5.7]	18.5 [5.4]	17.2 [5.1]	23.9 [7.0]	22.8 [6.7]	21.2 [6.2]	27.6 [8.1]	26.4 [7.7]	24.5 [7.2]	
	Power	3.3	3.2	3.2	3.3	3.2	3.2	3.2	3.2	3.2	
125 [51.7]	Total BTUH [kW]	31.4 [9.2]	30.8 [9.0]	30.0 [8.8]	28.7 [8.4]	28.2 [8.3]	27.4 [8.0]	26.2 [7.7]	25.8 [7.5]	25.1 [7.3]	
	Sens BTUH [kW]	18.4 [5.4]	17.6 [5.2]	16.4 [4.8]	22.9 [6.7]	21.9 [6.4]	20.3 [6.0]	26.2 [7.7]	25.4 [7.5]	23.6 [6.9]	
	Power	3.4	3.4	3.4	3.4	3.4	3.4	3.4	3.4	3.3	

DR —Depression ratio
 dbE —Entering air dry bulb
 wbE —Entering air wet bulb

Total —Total capacity x 1000 BTUH
 Sens —Sensible capacity x 1000 BTUH
 Power —KW input

NOTES: ① When the entering air dry bulb is other than 80°F [27°C], adjust the sensible capacity from the table by adding $[1.10 \times \text{CFM} \times (1 - \text{DR}) \times (\text{dbE} - 80)]$.

[] Designates Metric Conversions



GROSS SYSTEMS PERFORMANCE DATA—RKNN-A048

ENTERING INDOOR AIR @ 80°F [26.7°C] dbE ①											
wbE		71°F [21.7°C]			67°F [19.4°C]			63°F [17.2°C]			
CFM [L/s]		1650 [779]	1500 [708]	1275 [602]	1650 [779]	1500 [708]	1275 [602]	1650 [779]	1500 [708]	1275 [602]	
DR ①		0.1	0.08	0.05	0.1	0.08	0.05	0.1	0.08	0.05	
OUTDOOR DRY BULB TEMPERATURE °F [°C]	75 [23.9]	Total BTUH [kW] Sens BTUH [kW] Power	58.2 [17.1] 34.7 [10.2] 2.7	57.2 [16.8] 33.1 [9.7] 2.7	55.6 [16.3] 30.8 [9.0] 2.6	55.4 [16.2] 40.9 [12.0] 2.7	54.4 [15.9] 39.1 [11.5] 2.6	52.9 [15.5] 36.4 [10.7] 2.6	52.3 [15.3] 45.8 [13.4] 2.7	51.4 [15.1] 43.8 [12.8] 2.6	50.0 [14.6] 40.7 [11.9] 2.6
	80 [26.7]	Total BTUH [kW] Sens BTUH [kW] Power	56.7 [16.6] 34.0 [10.0] 2.8	55.7 [16.3] 32.4 [9.5] 2.8	54.1 [15.9] 30.2 [8.8] 2.8	53.8 [15.8] 40.2 [11.8] 2.8	52.9 [15.5] 38.4 [11.3] 2.8	51.4 [15.1] 35.7 [10.5] 2.8	50.8 [14.9] 45.1 [13.2] 2.8	49.9 [14.6] 43.1 [12.6] 2.8	48.5 [14.2] 40.1 [11.7] 2.7
	85 [29.4]	Total BTUH [kW] Sens BTUH [kW] Power	55.1 [16.1] 33.2 [9.7] 3.0	54.1 [15.9] 31.7 [9.3] 3.0	52.6 [15.4] 29.5 [8.6] 2.9	52.3 [15.3] 39.5 [11.6] 3.0	51.3 [15.0] 37.7 [11.1] 2.9	49.9 [14.6] 35.1 [10.3] 2.9	49.2 [14.4] 44.4 [13.0] 3.0	48.3 [14.2] 42.4 [12.4] 2.9	47.0 [13.8] 39.4 [11.6] 2.9
	90 [32.2]	Total BTUH [kW] Sens BTUH [kW] Power	53.5 [15.7] 32.4 [9.5] 3.2	52.5 [15.4] 31.0 [9.1] 3.1	51.1 [15.0] 28.8 [8.4] 3.1	50.7 [14.8] 38.7 [11.3] 3.1	49.8 [14.6] 37.0 [10.8] 3.1	48.4 [14.2] 34.4 [10.1] 3.1	47.6 [14.0] 43.6 [12.8] 3.1	46.8 [13.7] 41.6 [12.2] 3.1	45.5 [13.3] 38.7 [11.3] 3.1
	95 [35]	Total BTUH [kW] Sens BTUH [kW] Power	51.9 [15.2] 31.6 [9.3] 3.3	50.9 [14.9] 30.2 [8.8] 3.3	49.5 [14.5] 28.1 [8.2] 3.3	49.0 [14.4] 37.8 [11.1] 3.3	48.1 [14.1] 36.1 [10.6] 3.3	46.8 [13.7] 33.6 [9.9] 3.3	46.0 [13.5] 42.7 [12.5] 3.3	45.2 [13.2] 40.8 [12.0] 3.3	43.9 [12.9] 38.0 [11.1] 3.2
	100 [37.8]	Total BTUH [kW] Sens BTUH [kW] Power	50.2 [14.7] 30.7 [9.0] 3.5	49.3 [14.4] 29.3 [8.6] 3.5	47.9 [14.0] 27.3 [8.0] 3.5	47.3 [13.9] 36.9 [10.8] 3.5	46.5 [13.6] 35.3 [10.3] 3.5	45.2 [13.3] 32.8 [9.6] 3.5	44.3 [13.0] 41.8 [12.3] 3.5	43.5 [12.7] 40.0 [11.7] 3.5	42.3 [12.4] 37.2 [10.9] 3.4
	105 [40.6]	Total BTUH [kW] Sens BTUH [kW] Power	48.4 [14.2] 29.8 [8.7] 3.8	47.6 [13.9] 28.4 [8.3] 3.7	46.3 [13.6] 26.4 [7.7] 3.7	45.6 [13.4] 36.0 [10.6] 3.7	44.8 [13.1] 34.4 [10.1] 3.7	43.6 [12.8] 32.0 [9.4] 3.7	42.6 [12.5] 40.9 [12.0] 3.7	41.8 [12.2] 39.1 [11.5] 3.7	40.7 [11.9] 36.3 [10.7] 3.7
	110 [43.3]	Total BTUH [kW] Sens BTUH [kW] Power	46.7 [13.7] 28.8 [8.4] 4.0	45.8 [13.4] 27.5 [8.1] 4.0	44.6 [13.1] 25.6 [7.5] 3.9	43.8 [12.8] 35.0 [10.3] 4.0	43.1 [12.6] 33.5 [9.8] 3.9	41.9 [12.3] 31.1 [9.1] 3.9	40.8 [12.0] 39.9 [11.7] 4.0	40.1 [11.7] 38.1 [11.2] 3.9	39.0 [11.4] 35.5 [10.4] 3.9
	115 [46.1]	Total BTUH [kW] Sens BTUH [kW] Power	44.9 [13.1] 27.7 [8.1] 4.2	44.1 [12.9] 26.5 [7.8] 4.2	42.9 [12.6] 24.7 [7.2] 4.1	42.0 [12.3] 34.0 [10.0] 4.2	41.3 [12.1] 32.5 [9.5] 4.2	40.2 [11.8] 30.2 [8.9] 4.1	39.0 [11.4] 38.9 [11.4] 4.2	38.3 [11.2] 37.2 [10.9] 4.2	37.3 [10.9] 34.6 [10.1] 4.1
	120 [48.9]	Total BTUH [kW] Sens BTUH [kW] Power	43.0 [12.6] 26.7 [7.8] 4.5	42.3 [12.4] 25.5 [7.5] 4.5	41.1 [12.0] 23.7 [6.9] 4.4	40.2 [11.8] 32.9 [9.6] 4.5	39.5 [11.6] 31.5 [9.2] 4.4	38.4 [11.3] 29.3 [8.6] 4.4	37.1 [10.9] 37.1 [10.9] 4.5	36.5 [10.7] 36.1 [10.6] 4.4	35.5 [10.4] 33.6 [9.8] 4.4
125 [51.7]	Total BTUH [kW] Sens BTUH [kW] Power	41.1 [12.1] 25.5 [7.5] 4.8	40.4 [11.8] 24.4 [7.2] 4.7	39.3 [11.5] 22.7 [6.7] 4.7	38.3 [11.2] 31.8 [9.3] 4.8	37.6 [11.0] 30.4 [8.9] 4.7	36.6 [10.7] 28.3 [8.3] 4.7	35.3 [10.3] 35.3 [10.3] 4.7	34.6 [10.2] 34.6 [10.2] 4.7	33.7 [9.9] 32.6 [9.6] 4.6	

DR —Depression ratio
dbE —Entering air dry bulb
wbE —Entering air wet bulb

Total —Total capacity x 1000 BTUH
Sens —Sensible capacity x 1000 BTUH
Power —kW input

NOTES: ① When the entering air dry bulb is other than 80°F [27°C], adjust the sensible capacity from the table by adding [1.10 x CFM x (1 - DR) x (dbE - 80)].

[] Designates Metric Conversions





GROSS SYSTEMS PERFORMANCE DATA—RKNN-A060

ENTERING INDOOR AIR @ 80°F [26.7°C] dbE ①											
wbE		71°F [21.7°C]			67°F [19.4°C]			63°F [17.2°C]			
CFM [L/s]		2310 [1090]	1850 [873]	1380 [651]	2310 [1090]	1850 [873]	1380 [651]	2310 [1090]	1850 [873]	1380 [651]	
DR ①		0.17	0.13	0.08	0.17	0.13	0.08	0.17	0.13	0.08	
OUTDOOR DRY BULB TEMPERATURE °F [°C]	75 [23.9]	Total BTUH [kW]	75.8 [22.2]	72.6 [21.3]	69.2 [20.3]	71.6 [21.0]	68.5 [20.1]	65.4 [19.2]	67.5 [19.8]	64.6 [18.9]	61.6 [18.0]
		Sens BTUH [kW]	44.6 [13.1]	40.0 [11.7]	35.2 [10.3]	52.7 [15.4]	47.2 [13.8]	41.6 [12.2]	59.6 [17.5]	53.4 [15.7]	47.1 [13.8]
		Power	3.6	3.5	3.5	3.6	3.5	3.4	3.6	3.5	3.4
	80 [26.7]	Total BTUH [kW]	74.2 [21.7]	71.0 [20.8]	67.7 [19.8]	70.0 [20.5]	67.0 [19.6]	63.9 [18.7]	65.8 [19.3]	63.0 [18.5]	60.1 [17.6]
		Sens BTUH [kW]	44.0 [12.9]	39.4 [11.5]	34.7 [10.2]	52.0 [15.2]	46.6 [13.7]	41.1 [12.0]	59.0 [17.3]	52.8 [15.5]	46.6 [13.6]
		Power	3.8	3.7	3.6	3.8	3.7	3.6	3.8	3.7	3.6
	85 [29.4]	Total BTUH [kW]	72.5 [21.2]	69.3 [20.3]	66.1 [19.4]	68.2 [20.0]	65.3 [19.1]	62.3 [18.2]	64.1 [18.8]	61.3 [18.0]	58.5 [17.1]
		Sens BTUH [kW]	43.2 [12.6]	38.7 [11.3]	34.1 [10.0]	51.2 [15.0]	45.9 [13.4]	40.4 [11.9]	58.2 [17.0]	52.1 [15.3]	46.0 [13.5]
		Power	4.0	3.9	3.9	4.0	3.9	3.8	4.0	3.9	3.8
	90 [32.2]	Total BTUH [kW]	70.6 [20.7]	67.6 [19.8]	64.5 [18.9]	66.4 [19.5]	63.5 [18.6]	60.6 [17.8]	62.3 [18.2]	59.6 [17.5]	56.8 [16.7]
		Sens BTUH [kW]	42.3 [12.4]	37.9 [11.1]	33.4 [9.8]	50.3 [14.7]	45.1 [13.2]	39.7 [11.6]	57.3 [16.8]	51.3 [15.0]	45.2 [13.3]
		Power	4.3	4.2	4.1	4.2	4.1	4.1	4.2	4.1	4.0
95 [35]	Total BTUH [kW]	68.7 [20.1]	65.7 [19.3]	62.7 [18.4]	64.5 [18.9]	61.7 [18.1]	58.8 [17.2]	60.3 [17.7]	57.7 [16.9]	55.1 [16.1]	
	Sens BTUH [kW]	41.3 [12.1]	37.0 [10.8]	32.6 [9.6]	49.3 [14.5]	44.2 [13.0]	39.0 [11.4]	56.3 [16.5]	50.4 [14.8]	44.5 [13.0]	
	Power	4.5	4.4	4.3	4.5	4.4	4.3	4.5	4.4	4.3	
100 [37.8]	Total BTUH [kW]	66.7 [19.5]	63.8 [18.7]	60.9 [17.8]	62.5 [18.3]	59.8 [17.5]	57.0 [16.7]	58.3 [17.1]	55.8 [16.4]	53.2 [15.6]	
	Sens BTUH [kW]	40.2 [11.8]	36.0 [10.6]	31.7 [9.3]	48.2 [14.1]	43.2 [12.7]	38.1 [11.2]	55.2 [16.2]	49.5 [14.5]	43.6 [12.8]	
	Power	4.8	4.7	4.6	4.8	4.7	4.6	4.8	4.7	4.6	
105 [40.6]	Total BTUH [kW]	64.6 [18.9]	61.8 [18.1]	58.9 [17.3]	60.4 [17.7]	57.8 [16.9]	55.1 [16.1]	56.2 [16.5]	53.8 [15.8]	51.3 [15.0]	
	Sens BTUH [kW]	39.0 [11.4]	34.9 [10.2]	30.8 [9.0]	47.0 [13.8]	42.1 [12.4]	37.1 [10.9]	54.0 [15.8]	48.4 [14.2]	42.7 [12.5]	
	Power	5.1	5.0	4.9	5.1	5.0	4.9	5.1	5.0	4.8	
110 [43.3]	Total BTUH [kW]	62.4 [18.3]	59.7 [17.5]	56.9 [16.7]	58.2 [17.0]	55.7 [16.3]	53.1 [15.6]	54.0 [15.8]	51.7 [15.1]	49.3 [14.4]	
	Sens BTUH [kW]	37.7 [11.0]	33.8 [9.9]	29.8 [8.7]	45.7 [13.4]	41.0 [12.0]	36.1 [10.6]	52.7 [15.4]	47.2 [13.8]	41.6 [12.2]	
	Power	5.4	5.3	5.2	5.4	5.3	5.2	5.4	5.3	5.2	
115 [46.1]	Total BTUH [kW]	60.1 [17.6]	57.5 [16.8]	54.8 [16.1]	55.9 [16.4]	53.5 [15.7]	51.0 [14.9]	51.7 [15.2]	49.5 [14.5]	47.2 [13.8]	
	Sens BTUH [kW]	36.3 [10.6]	32.5 [9.5]	28.7 [8.4]	44.3 [13.0]	39.7 [11.6]	35.0 [10.3]	51.3 [15.0]	46.0 [13.5]	40.5 [11.9]	
	Power	5.8	5.7	5.5	5.8	5.6	5.5	5.7	5.6	5.5	
120 [48.9]	Total BTUH [kW]	57.7 [16.9]	55.2 [16.2]	52.7 [15.4]	53.5 [15.7]	51.2 [15.0]	48.8 [14.3]	49.4 [14.5]	47.2 [13.8]	45.0 [13.2]	
	Sens BTUH [kW]	34.8 [10.2]	31.2 [9.1]	27.5 [8.1]	42.8 [12.5]	38.4 [11.2]	33.8 [9.9]	49.4 [14.5]	44.6 [13.1]	39.3 [11.5]	
	Power	6.1	6.0	5.9	6.1	6.0	5.9	6.1	6.0	5.8	
125 [51.7]	Total BTUH [kW]	55.2 [16.2]	52.8 [15.5]	50.4 [14.8]	51.0 [14.9]	48.8 [14.3]	46.6 [13.6]	46.9 [13.7]	44.8 [13.1]	42.8 [12.5]	
	Sens BTUH [kW]	33.2 [9.7]	29.7 [8.7]	26.2 [7.7]	41.2 [12.1]	36.9 [10.8]	32.5 [9.5]	46.9 [13.7]	43.2 [12.7]	38.1 [11.2]	
	Power	6.5	6.4	6.3	6.5	6.4	6.2	6.5	6.4	6.2	

DR —Depression ratio
dbE —Entering air dry bulb
wbE—Entering air wet bulb

Total —Total capacity x 1000 BTUH
Sens —Sensible capacity x 1000 BTUH
Power —KW input

NOTES: ① When the entering air dry bulb is other than 80°F [27°C], adjust the sensible capacity from the table by adding [1.10 x CFM x (1 – DR) x (dbE – 80)].

[] Designates Metric Conversions





GROSS SYSTEMS PERFORMANCE DATA—RKPN-A036

ENTERING INDOOR AIR @ 80°F [26.7°C] dbE ①											
wbE		71°F [21.7°C]			67°F [19.4°C]			63°F [17.2°C]			
CFM [L/s]		1375 [649]	1250 [590]	1062 [501]	1375 [649]	1250 [590]	1062 [501]	1375 [649]	1250 [590]	1062 [501]	
DR ①		0.2	0.18	0.15	0.2	0.18	0.15	0.2	0.18	0.15	
OUTDOOR DRY BULB TEMPERATURE °F [°C]	75 [23.9]	Total BTUH [kW] Sens BTUH [kW] Power	45.1 [13.2] 26.6 [7.8] 2.0	44.3 [13.0] 25.4 [7.5] 2.0	43.1 [12.6] 23.6 [6.9] 2.0	42.4 [12.4] 31.1 [9.1] 2.0	41.6 [12.2] 29.7 [8.7] 2.0	40.5 [11.9] 27.6 [8.1] 1.9	39.9 [11.7] 34.8 [10.2] 2.0	39.2 [11.5] 33.2 [9.7] 1.9	38.1 [11.2] 30.9 [9.1] 1.9
	80 [26.7]	Total BTUH [kW] Sens BTUH [kW] Power	43.7 [12.8] 26.0 [7.6] 2.1	42.9 [12.6] 24.8 [7.3] 2.1	41.8 [12.2] 23.1 [6.8] 2.1	41.0 [12.0] 30.4 [8.9] 2.1	40.3 [11.8] 29.0 [8.5] 2.1	39.2 [11.5] 27.0 [7.9] 2.0	38.6 [11.3] 34.1 [10.0] 2.1	37.9 [11.1] 32.6 [9.6] 2.1	36.8 [10.8] 30.3 [8.9] 2.0
	85 [29.4]	Total BTUH [kW] Sens BTUH [kW] Power	42.4 [12.4] 25.3 [7.4] 2.2	41.6 [12.2] 24.1 [7.1] 2.2	40.5 [11.9] 22.5 [6.6] 2.2	39.7 [11.6] 29.7 [8.7] 2.2	38.9 [11.4] 28.4 [8.3] 2.2	37.9 [11.1] 26.4 [7.7] 2.2	37.2 [10.9] 33.5 [9.8] 2.2	36.5 [10.7] 32.0 [9.4] 2.2	35.5 [10.4] 29.7 [8.7] 2.1
	90 [32.2]	Total BTUH [kW] Sens BTUH [kW] Power	41.0 [12.0] 24.5 [7.2] 2.4	40.3 [11.8] 23.5 [6.9] 2.3	39.2 [11.5] 21.8 [6.4] 2.3	38.3 [11.2] 29.0 [8.5] 2.3	37.6 [11.0] 27.7 [8.1] 2.3	36.6 [10.7] 25.8 [7.5] 2.3	35.8 [10.5] 32.7 [9.6] 2.3	35.2 [10.3] 31.3 [9.2] 2.3	34.2 [10.0] 29.1 [8.5] 2.3
	95 [35]	Total BTUH [kW] Sens BTUH [kW] Power	39.6 [11.6] 23.8 [7.0] 2.5	38.9 [11.4] 22.7 [6.7] 2.5	37.9 [11.1] 21.1 [6.2] 2.4	36.9 [10.8] 28.2 [8.3] 2.5	36.3 [10.6] 27.0 [7.9] 2.5	35.3 [10.3] 25.1 [7.3] 2.4	34.5 [10.1] 32.0 [9.4] 2.5	33.9 [9.9] 30.5 [9.0] 2.4	32.9 [9.7] 28.4 [8.3] 2.4
	100 [37.8]	Total BTUH [kW] Sens BTUH [kW] Power	38.3 [11.2] 23.0 [6.7] 2.6	37.6 [11.0] 22.0 [6.4] 2.6	36.6 [10.7] 20.4 [6.0] 2.6	35.6 [10.4] 27.4 [8.0] 2.6	34.9 [10.2] 26.2 [7.7] 2.6	34.0 [10.0] 24.4 [7.1] 2.6	33.1 [9.7] 31.2 [9.1] 2.6	32.5 [9.5] 29.8 [8.7] 2.6	31.6 [9.3] 27.7 [8.1] 2.5
	105 [40.6]	Total BTUH [kW] Sens BTUH [kW] Power	36.9 [10.8] 22.2 [6.5] 2.8	36.3 [10.6] 21.2 [6.2] 2.8	35.3 [10.3] 19.7 [5.8] 2.7	34.2 [10.0] 26.6 [7.8] 2.8	33.6 [9.8] 25.4 [7.4] 2.8	32.7 [9.6] 23.6 [6.9] 2.7	31.8 [9.3] 30.3 [8.9] 2.8	31.2 [9.1] 29.0 [8.5] 2.7	30.3 [8.9] 27.0 [7.9] 2.7
	110 [43.3]	Total BTUH [kW] Sens BTUH [kW] Power	35.5 [10.4] 21.3 [6.2] 3.0	34.9 [10.2] 20.3 [6.0] 2.9	34.0 [9.9] 18.9 [5.5] 2.9	32.8 [9.6] 25.7 [7.5] 2.9	32.2 [9.4] 24.6 [7.2] 2.9	31.4 [9.2] 22.9 [6.7] 2.9	30.4 [8.9] 29.5 [8.6] 2.9	29.8 [8.7] 28.2 [8.3] 2.9	29.0 [8.5] 26.2 [7.7] 2.8
	115 [46.1]	Total BTUH [kW] Sens BTUH [kW] Power	34.2 [10.0] 20.4 [6.0] 3.1	33.6 [9.8] 19.5 [5.7] 3.1	32.6 [9.6] 18.1 [5.3] 3.0	31.5 [9.2] 24.8 [7.3] 3.1	30.9 [9.1] 23.7 [7.0] 3.1	30.1 [8.8] 22.1 [6.5] 3.0	29.0 [8.5] 28.6 [8.4] 3.1	28.5 [8.3] 27.3 [8.0] 3.0	27.7 [8.1] 25.4 [7.4] 3.0
	120 [48.9]	Total BTUH [kW] Sens BTUH [kW] Power	32.8 [9.6] 19.4 [5.7] 3.3	32.2 [9.4] 18.6 [5.4] 3.3	31.3 [9.2] 17.3 [5.1] 3.2	30.1 [8.8] 23.9 [7.0] 3.3	29.5 [8.7] 22.8 [6.7] 3.2	28.7 [8.4] 21.2 [6.2] 3.2	27.6 [8.1] 27.6 [8.1] 3.2	27.1 [8.0] 26.4 [7.7] 3.2	26.4 [7.7] 24.5 [7.2] 3.2
125 [51.7]	Total BTUH [kW] Sens BTUH [kW] Power	31.4 [9.2] 18.5 [5.4] 3.5	30.9 [9.0] 17.6 [5.2] 3.4	30.0 [8.8] 16.4 [4.8] 3.4	28.7 [8.4] 22.9 [6.7] 3.4	28.2 [8.3] 21.9 [6.4] 3.4	27.4 [8.0] 20.4 [6.0] 3.4	26.3 [7.7] 26.3 [7.7] 3.4	25.8 [7.6] 25.5 [7.5] 3.4	25.1 [7.4] 23.7 [6.9] 3.3	

DR —Depression ratio
dbE —Entering air dry bulb
wbE —Entering air wet bulb

Total —Total capacity x 1000 BTUH
Sens —Sensible capacity x 1000 BTUH
Power —kW input

NOTES: ① When the entering air dry bulb is other than 80°F [27°C], adjust the sensible capacity from the table by adding [1.10 x CFM x (1 - DR) x (dbE - 80)].

[] Designates Metric Conversions



GROSS SYSTEMS PERFORMANCE DATA—RKPN-A048

		ENTERING INDOOR AIR @ 80°F [26.7°C] dbE ①									
wbE		71°F [21.7°C]			67°F [19.4°C]			63°F [17.2°C]			
CFM [L/s]		1650 [779]	1500 [708]	1275 [602]	1650 [779]	1500 [708]	1275 [602]	1650 [779]	1500 [708]	1275 [602]	
DR ①		0.1	0.08	0.05	0.1	0.08	0.05	0.1	0.08	0.05	
OUTDOOR DRY BULB TEMPERATURE °F [°C]	75 [23.9]	Total BTUH [kW] Sens BTUH [kW] Power	58.2 [17.1] 34.7 [10.2] 2.7	57.2 [16.8] 33.1 [9.7] 2.7	55.6 [16.3] 30.8 [9.0] 2.6	55.4 [16.2] 40.9 [12.0] 2.7	54.4 [15.9] 39.1 [11.5] 2.6	52.9 [15.5] 36.4 [10.7] 2.6	52.3 [15.3] 45.8 [13.4] 2.7	51.4 [15.1] 43.8 [12.8] 2.6	50.0 [14.6] 40.7 [11.9] 2.6
	80 [26.7]	Total BTUH [kW] Sens BTUH [kW] Power	56.7 [16.6] 34.0 [10.0] 2.8	55.7 [16.3] 32.4 [9.5] 2.8	54.1 [15.9] 30.2 [8.8] 2.8	53.8 [15.8] 40.2 [11.8] 2.8	52.9 [15.5] 38.4 [11.3] 2.8	51.4 [15.1] 35.7 [10.5] 2.8	50.8 [14.9] 45.1 [13.2] 2.8	49.9 [14.6] 43.1 [12.6] 2.8	48.5 [14.2] 40.1 [11.7] 2.7
	85 [29.4]	Total BTUH [kW] Sens BTUH [kW] Power	55.1 [16.1] 33.2 [9.7] 3.0	54.1 [15.9] 31.7 [9.3] 3.0	52.6 [15.4] 29.5 [8.6] 2.9	52.3 [15.3] 39.5 [11.6] 3.0	51.3 [15.0] 37.7 [11.1] 2.9	49.9 [14.6] 35.1 [10.3] 2.9	49.2 [14.4] 44.4 [13.0] 3.0	48.3 [14.2] 42.4 [12.4] 2.9	47.0 [13.8] 39.4 [11.6] 2.9
	90 [32.2]	Total BTUH [kW] Sens BTUH [kW] Power	53.5 [15.7] 32.4 [9.5] 3.2	52.5 [15.4] 31.0 [9.1] 3.1	51.1 [15.0] 28.8 [8.4] 3.1	50.7 [14.8] 38.7 [11.3] 3.1	49.8 [14.6] 37.0 [10.8] 3.1	48.4 [14.2] 34.4 [10.1] 3.1	47.6 [14.0] 43.6 [12.8] 3.1	46.8 [13.7] 41.6 [12.2] 3.1	45.5 [13.3] 38.7 [11.3] 3.1
	95 [35]	Total BTUH [kW] Sens BTUH [kW] Power	51.9 [15.2] 31.6 [9.3] 3.3	50.9 [14.9] 30.2 [8.8] 3.3	49.5 [14.5] 28.1 [8.2] 3.3	49.0 [14.4] 37.8 [11.1] 3.3	48.1 [14.1] 36.1 [10.6] 3.3	46.8 [13.7] 33.6 [9.9] 3.3	46.0 [13.5] 42.7 [12.5] 3.3	45.2 [13.2] 40.8 [12.0] 3.3	43.9 [12.9] 38.0 [11.1] 3.2
	100 [37.8]	Total BTUH [kW] Sens BTUH [kW] Power	50.2 [14.7] 30.7 [9.0] 3.5	49.3 [14.4] 29.3 [8.6] 3.5	47.9 [14.0] 27.3 [8.0] 3.5	47.3 [13.9] 36.9 [10.8] 3.5	46.5 [13.6] 35.3 [10.3] 3.5	45.2 [13.3] 32.8 [9.6] 3.5	44.3 [13.0] 41.8 [12.3] 3.5	43.5 [12.7] 40.0 [11.7] 3.5	42.3 [12.4] 37.2 [10.9] 3.4
	105 [40.6]	Total BTUH [kW] Sens BTUH [kW] Power	48.4 [14.2] 29.8 [8.7] 3.8	47.6 [13.9] 28.4 [8.3] 3.7	46.3 [13.6] 26.4 [7.7] 3.7	45.6 [13.4] 36.0 [10.6] 3.7	44.8 [13.1] 34.4 [10.1] 3.7	43.6 [12.8] 32.0 [9.4] 3.7	42.6 [12.5] 40.9 [12.0] 3.7	41.8 [12.2] 39.1 [11.5] 3.7	40.7 [11.9] 36.3 [10.7] 3.7
	110 [43.3]	Total BTUH [kW] Sens BTUH [kW] Power	46.7 [13.7] 28.8 [8.4] 4.0	45.8 [13.4] 27.5 [8.1] 4.0	44.6 [13.1] 25.6 [7.5] 3.9	43.8 [12.8] 35.0 [10.3] 4.0	43.1 [12.6] 33.5 [9.8] 3.9	41.9 [12.3] 31.1 [9.1] 3.9	40.8 [12.0] 39.9 [11.7] 4.0	40.1 [11.7] 38.1 [11.2] 3.9	39.0 [11.4] 35.5 [10.4] 3.9
	115 [46.1]	Total BTUH [kW] Sens BTUH [kW] Power	44.9 [13.1] 27.7 [8.1] 4.2	44.1 [12.9] 26.5 [7.8] 4.2	42.9 [12.6] 24.7 [7.2] 4.1	42.0 [12.3] 34.0 [10.0] 4.2	41.3 [12.1] 32.5 [9.5] 4.2	40.2 [11.8] 30.2 [8.9] 4.1	39.0 [11.4] 38.9 [11.4] 4.2	38.3 [11.2] 37.2 [10.9] 4.2	37.3 [10.9] 34.6 [10.1] 4.1
	120 [48.9]	Total BTUH [kW] Sens BTUH [kW] Power	43.0 [12.6] 26.7 [7.8] 4.5	42.3 [12.4] 25.5 [7.5] 4.5	41.1 [12.0] 23.7 [6.9] 4.4	40.2 [11.8] 32.9 [9.6] 4.5	39.5 [11.6] 31.5 [9.2] 4.4	38.4 [11.3] 29.3 [8.6] 4.4	37.1 [10.9] 37.1 [10.9] 4.5	36.5 [10.7] 36.1 [10.6] 4.4	35.5 [10.4] 33.6 [9.8] 4.4
125 [51.7]	Total BTUH [kW] Sens BTUH [kW] Power	41.1 [12.1] 25.5 [7.5] 4.8	40.4 [11.8] 24.4 [7.2] 4.7	39.3 [11.5] 22.7 [6.7] 4.7	38.3 [11.2] 31.8 [9.3] 4.8	37.6 [11.0] 30.4 [8.9] 4.7	36.6 [10.7] 28.3 [8.3] 4.7	35.3 [10.3] 35.3 [10.3] 4.7	34.6 [10.2] 34.6 [10.2] 4.7	33.7 [9.9] 32.6 [9.6] 4.6	

DR —Depression ratio
 dbE —Entering air dry bulb
 wbE—Entering air wet bulb

Total —Total capacity x 1000 BTUH
 Sens —Sensible capacity x 1000 BTUH
 Power —KW input

NOTES: ① When the entering air dry bulb is other than 80°F [27°C], adjust the sensible capacity from the table by adding [1.10 x CFM x (1 – DR) x (dbE – 80)].

[] Designates Metric Conversions



GROSS SYSTEMS PERFORMANCE DATA—RKPN-A060

ENTERING INDOOR AIR @ 80°F [26.7°C] dbE ①											
wbE		71°F [21.7°C]			67°F [19.4°C]			63°F [17.2°C]			
CFM [L/s]		1980 [934]	1800 [850]	1530 [722]	1980 [934]	1800 [850]	1530 [722]	1980 [934]	1800 [850]	1530 [722]	
DR ①		0.13	0.12	0.09	0.13	0.12	0.09	0.13	0.12	0.09	
OUTDOOR DRY BULB TEMPERATURE °F [°C]	75 [23.9]	Total BTUH [kW] Sens BTUH [kW] Power	72.0 [21.1] 41.1 [12.0] 3.7	70.7 [20.7] 39.2 [11.5] 3.6	68.8 [20.1] 36.5 [10.7] 3.6	68.2 [20.0] 48.6 [14.2] 3.6	67.0 [19.6] 46.4 [13.6] 3.6	65.2 [19.1] 43.2 [12.6] 3.5	64.8 [19.0] 55.7 [16.3] 3.6	63.6 [18.6] 53.2 [15.6] 3.6	61.9 [18.1] 49.5 [14.5] 3.5
	80 [26.7]	Total BTUH [kW] Sens BTUH [kW] Power	70.4 [20.6] 40.4 [11.8] 3.9	69.1 [20.3] 38.6 [11.3] 3.8	67.2 [19.7] 35.9 [10.5] 3.8	66.6 [19.5] 47.9 [14.0] 3.8	65.4 [19.2] 45.8 [13.4] 3.8	63.7 [18.7] 42.6 [12.5] 3.7	63.2 [18.5] 55.1 [16.1] 3.8	62.1 [18.2] 52.6 [15.4] 3.8	60.4 [17.7] 48.9 [14.3] 3.7
	85 [29.4]	Total BTUH [kW] Sens BTUH [kW] Power	68.7 [20.1] 39.6 [11.6] 4.1	67.5 [19.8] 37.9 [11.1] 4.0	65.6 [19.2] 35.2 [10.3] 4.0	64.9 [19.0] 47.1 [13.8] 4.0	63.8 [18.7] 45.0 [13.2] 4.0	62.0 [18.2] 41.9 [12.3] 4.0	61.5 [18.0] 54.3 [15.9] 4.0	60.4 [17.7] 51.9 [15.2] 4.0	58.8 [17.2] 48.2 [14.1] 3.9
	90 [32.2]	Total BTUH [kW] Sens BTUH [kW] Power	66.9 [19.6] 38.8 [11.4] 4.3	65.7 [19.3] 37.0 [10.9] 4.3	63.9 [18.7] 34.5 [10.1] 4.2	63.1 [18.5] 46.3 [13.6] 4.3	62.0 [18.2] 44.2 [13.0] 4.2	60.3 [17.7] 41.1 [12.1] 4.2	59.7 [17.5] 53.4 [15.7] 4.2	58.6 [17.2] 51.1 [15.0] 4.2	57.0 [16.7] 47.5 [13.9] 4.1
	95 [35]	Total BTUH [kW] Sens BTUH [kW] Power	65.0 [19.0] 37.8 [11.1] 4.5	63.8 [18.7] 36.2 [10.6] 4.5	62.1 [18.2] 33.6 [9.9] 4.4	61.2 [17.9] 45.4 [13.3] 4.5	60.1 [17.6] 43.3 [12.7] 4.5	58.5 [17.1] 40.3 [11.8] 4.4	57.8 [16.9] 52.5 [15.4] 4.5	56.8 [16.6] 50.2 [14.7] 4.4	55.2 [16.2] 46.7 [13.7] 4.4
	100 [37.8]	Total BTUH [kW] Sens BTUH [kW] Power	63.0 [18.5] 36.8 [10.8] 4.8	61.9 [18.1] 35.2 [10.3] 4.8	60.2 [17.6] 32.7 [9.6] 4.7	59.2 [17.4] 44.3 [13.0] 4.8	58.2 [17.0] 42.4 [12.4] 4.7	56.6 [16.6] 39.4 [11.5] 4.7	55.8 [16.3] 51.5 [15.1] 4.7	54.8 [16.1] 49.2 [14.4] 4.7	53.3 [15.6] 45.8 [13.4] 4.6
	105 [40.6]	Total BTUH [kW] Sens BTUH [kW] Power	60.9 [17.8] 35.7 [10.5] 5.1	59.8 [17.5] 34.1 [10.0] 5.0	58.1 [17.0] 31.7 [9.3] 5.0	57.1 [16.7] 43.2 [12.7] 5.0	56.1 [16.4] 41.3 [12.1] 5.0	54.5 [16.0] 38.4 [11.3] 4.9	53.7 [15.7] 50.4 [14.8] 5.0	52.7 [15.4] 48.1 [14.1] 5.0	51.3 [15.0] 44.8 [13.1] 4.9
	110 [43.3]	Total BTUH [kW] Sens BTUH [kW] Power	58.6 [17.2] 34.5 [10.1] 5.3	57.6 [16.9] 33.0 [9.7] 5.3	56.0 [16.4] 30.7 [9.0] 5.2	54.9 [16.1] 42.0 [12.3] 5.3	53.9 [15.8] 40.2 [11.8] 5.3	52.4 [15.4] 37.4 [10.9] 5.2	51.4 [15.1] 49.2 [14.4] 5.3	50.5 [14.8] 47.0 [13.8] 5.2	49.1 [14.4] 43.7 [12.8] 5.2
	115 [46.1]	Total BTUH [kW] Sens BTUH [kW] Power	56.3 [16.5] 33.2 [9.7] 5.6	55.3 [16.2] 31.8 [9.3] 5.6	53.8 [15.8] 29.5 [8.7] 5.5	52.5 [15.4] 40.8 [11.9] 5.6	51.6 [15.1] 38.9 [11.4] 5.6	50.2 [14.7] 36.2 [10.6] 5.5	49.1 [14.4] 47.9 [14.0] 5.6	48.2 [14.1] 45.8 [13.4] 5.5	46.9 [13.7] 42.6 [12.5] 5.5
	120 [48.9]	Total BTUH [kW] Sens BTUH [kW] Power	53.8 [15.8] 31.9 [9.3] 6.0	52.9 [15.5] 30.5 [8.9] 5.9	51.4 [15.1] 28.3 [8.3] 5.8	50.1 [14.7] 39.4 [11.5] 5.9	49.2 [14.4] 37.6 [11.0] 5.9	47.8 [14.0] 35.0 [10.3] 5.8	46.6 [13.7] 46.6 [13.6] 5.9	45.8 [13.4] 44.5 [13.0] 5.8	44.6 [13.1] 41.4 [12.1] 5.8
125 [51.7]	Total BTUH [kW] Sens BTUH [kW] Power	51.3 [15.0] 30.4 [8.9] 6.3	50.4 [14.8] 29.1 [8.5] 6.2	49.0 [14.4] 27.0 [7.9] 6.1	47.5 [13.9] 38.0 [11.1] 6.3	46.7 [13.7] 36.3 [10.6] 6.2	45.4 [13.3] 33.7 [9.9] 6.1	44.1 [12.9] 44.1 [12.9] 6.2	43.3 [12.7] 43.1 [12.6] 6.2	42.1 [12.3] 40.1 [11.7] 6.1	

DR —Depression ratio
dbE —Entering air dry bulb
wbE —Entering air wet bulb

Total —Total capacity x 1000 BTUH
Sens —Sensible capacity x 1000 BTUH
Power —kW input

NOTES: ① When the entering air dry bulb is other than 80°F [27°C], adjust the sensible capacity from the table by adding [1.10 x CFM x (1 - DR) x (dbE - 80)].

[] Designates Metric Conversions





GROSS SYSTEMS PERFORMANCE DATA—RKQN-A036

ENTERING INDOOR AIR @ 80°F [26.7°C] dbE ①											
wbE		71°F [21.7°C]			67°F [19.4°C]			63°F [17.2°C]			
CFM [L/s]		1375 [649]	1250 [590]	1062 [501]	1375 [649]	1250 [590]	1062 [501]	1375 [649]	1250 [590]	1062 [501]	
DR ①		0.19	0.17	0.14	0.19	0.17	0.14	0.19	0.17	0.14	
OUTDOOR DRY BULB TEMPERATURE °F [°C]	75 [23.9]	Total BTUH [kW] Sens BTUH [kW] Power	44.3 [13.0] 25.8 [7.6] 2.0	43.6 [12.8] 24.7 [7.2] 2.0	42.4 [12.4] 22.9 [6.7] 2.0	41.9 [12.3] 30.7 [9.0] 2.0	41.1 [12.1] 29.3 [8.6] 2.0	40.0 [11.7] 27.2 [8.0] 2.0	39.8 [11.7] 34.6 [10.1] 2.0	39.1 [11.5] 33.1 [9.7] 2.0	38.0 [11.1] 30.7 [9.0] 1.9
	80 [26.7]	Total BTUH [kW] Sens BTUH [kW] Power	43.2 [12.7] 25.3 [7.4] 2.1	42.4 [12.4] 24.2 [7.1] 2.1	41.2 [12.1] 22.5 [6.6] 2.1	40.7 [11.9] 30.1 [8.8] 2.1	40.0 [11.7] 28.8 [8.4] 2.1	38.9 [11.4] 26.8 [7.8] 2.1	38.6 [11.3] 34.1 [10.0] 2.1	37.9 [11.1] 32.6 [9.5] 2.1	36.9 [10.8] 30.3 [8.9] 2.1
	85 [29.4]	Total BTUH [kW] Sens BTUH [kW] Power	42.0 [12.3] 24.7 [7.2] 2.2	41.2 [12.1] 23.6 [6.9] 2.2	40.1 [11.7] 22.0 [6.4] 2.2	39.5 [11.6] 29.6 [8.7] 2.2	38.8 [11.4] 28.3 [8.3] 2.2	37.7 [11.1] 26.3 [7.7] 2.2	37.4 [11.0] 33.5 [9.8] 2.2	36.7 [10.8] 32.0 [9.4] 2.2	35.7 [10.5] 29.8 [8.7] 2.2
	90 [32.2]	Total BTUH [kW] Sens BTUH [kW] Power	40.7 [11.9] 24.1 [7.1] 2.4	40.0 [11.7] 23.1 [6.8] 2.3	38.9 [11.4] 21.4 [6.3] 2.3	38.2 [11.2] 29.0 [8.5] 2.3	37.6 [11.0] 27.7 [8.1] 2.3	36.5 [10.7] 25.8 [7.5] 2.3	36.2 [10.6] 32.9 [9.7] 2.3	35.5 [10.4] 31.5 [9.2] 2.3	34.5 [10.1] 29.3 [8.6] 2.3
	95 [35]	Total BTUH [kW] Sens BTUH [kW] Power	39.4 [11.6] 23.5 [6.9] 2.5	38.7 [11.3] 22.5 [6.6] 2.5	37.7 [11.0] 20.9 [6.1] 2.4	36.9 [10.8] 28.4 [8.3] 2.5	36.3 [10.6] 27.1 [7.9] 2.5	35.3 [10.3] 25.2 [7.4] 2.4	34.9 [10.2] 32.3 [9.5] 2.5	34.3 [10.0] 30.9 [9.0] 2.4	33.3 [9.8] 28.7 [8.4] 2.4
	100 [37.8]	Total BTUH [kW] Sens BTUH [kW] Power	38.1 [11.2] 22.8 [6.7] 2.6	37.4 [11.0] 21.8 [6.4] 2.6	36.4 [10.7] 20.3 [5.9] 2.6	35.6 [10.4] 27.7 [8.1] 2.6	35.0 [10.3] 26.4 [7.7] 2.6	34.0 [10.0] 24.6 [7.2] 2.6	33.5 [9.8] 31.6 [9.3] 2.6	32.9 [9.7] 30.2 [8.9] 2.6	32.0 [9.4] 28.1 [8.2] 2.6
	105 [40.6]	Total BTUH [kW] Sens BTUH [kW] Power	36.7 [10.8] 22.1 [6.5] 2.8	36.1 [10.6] 21.1 [6.2] 2.8	35.1 [10.3] 19.7 [5.8] 2.7	34.3 [10.0] 27.0 [7.9] 2.8	33.6 [9.9] 25.8 [7.6] 2.7	32.7 [9.6] 24.0 [7.0] 2.7	32.2 [9.4] 30.9 [9.1] 2.8	31.6 [9.3] 29.5 [8.7] 2.7	30.7 [9.0] 27.5 [8.0] 2.7
	110 [43.3]	Total BTUH [kW] Sens BTUH [kW] Power	35.3 [10.4] 21.4 [6.3] 2.9	34.7 [10.2] 20.4 [6.0] 2.9	33.7 [9.9] 19.0 [5.6] 2.9	32.9 [9.6] 26.2 [7.7] 2.9	32.3 [9.5] 25.0 [7.3] 2.9	31.4 [9.2] 23.3 [6.8] 2.9	30.8 [9.0] 30.2 [8.8] 2.9	30.2 [8.9] 28.8 [8.4] 2.9	29.4 [8.6] 26.8 [7.9] 2.9
	115 [46.1]	Total BTUH [kW] Sens BTUH [kW] Power	33.9 [9.9] 20.6 [6.0] 3.1	33.3 [9.8] 19.7 [5.8] 3.1	32.4 [9.5] 18.3 [5.4] 3.0	31.4 [9.2] 25.4 [7.5] 3.1	30.8 [9.0] 24.3 [7.1] 3.1	30.0 [8.8] 22.6 [6.6] 3.0	29.3 [8.6] 29.3 [8.6] 3.1	28.8 [8.4] 28.1 [8.2] 3.1	28.0 [8.2] 26.1 [7.6] 3.0
	120 [48.9]	Total BTUH [kW] Sens BTUH [kW] Power	32.4 [9.5] 19.8 [5.8] 3.3	31.8 [9.3] 18.9 [5.5] 3.3	31.0 [9.1] 17.6 [5.1] 3.2	29.9 [8.8] 24.6 [7.2] 3.3	29.4 [8.6] 23.5 [6.9] 3.2	28.6 [8.4] 21.9 [6.4] 3.2	27.9 [8.2] 27.9 [8.2] 3.3	27.4 [8.0] 27.3 [8.0] 3.2	26.6 [7.8] 25.4 [7.4] 3.2
125 [51.7]	Total BTUH [kW] Sens BTUH [kW] Power	30.9 [9.1] 18.9 [5.5] 3.5	30.3 [8.9] 18.1 [5.3] 3.4	29.5 [8.6] 16.8 [4.9] 3.4	28.4 [8.3] 23.7 [7.0] 3.5	27.9 [8.2] 22.7 [6.6] 3.4	27.1 [8.0] 21.1 [6.2] 3.4	26.3 [7.7] 26.3 [7.7] 3.4	25.9 [7.6] 25.9 [7.6] 3.4	25.2 [7.4] 24.6 [7.2] 3.4	

DR —Depression ratio
dbE —Entering air dry bulb
wbE —Entering air wet bulb

Total —Total capacity x 1000 BTUH
Sens —Sensible capacity x 1000 BTUH
Power —KW input

NOTES: ① When the entering air dry bulb is other than 80°F [27°C], adjust the sensible capacity from the table by adding [1.10 x CFM x (1 – DR) x (dbE – 80)].

[] Designates Metric Conversions



GROSS SYSTEMS PERFORMANCE DATA—RKQN-A048

ENTERING INDOOR AIR @ 80°F [26.7°C] dbE ①											
wbE		71°F [21.7°C]			67°F [19.4°C]			63°F [17.2°C]			
CFM [L/s]		1760 [831]	1600 [755]	1360 [642]	1760 [831]	1600 [755]	1360 [642]	1760 [831]	1600 [755]	1360 [642]	
DR ①		0.11	0.09	0.05	0.11	0.09	0.05	0.11	0.09	0.05	
OUTDOOR DRY BULB TEMPERATURE °F [°C]	75 [23.9]	Total BTUH [kW] Sens BTUH [kW] Power	57.9 [17.0] 34.8 [10.2] 2.7	56.9 [16.7] 33.2 [9.7] 2.7	55.3 [16.2] 30.9 [9.1] 2.6	55.0 [16.1] 41.4 [12.1] 2.7	54.0 [15.8] 39.6 [11.6] 2.7	52.5 [15.4] 36.8 [10.8] 2.6	52.3 [15.3] 46.2 [13.5] 2.7	51.4 [15.1] 44.2 [12.9] 2.6	50.0 [14.6] 41.1 [12.0] 2.6
	80 [26.7]	Total BTUH [kW] Sens BTUH [kW] Power	56.4 [16.5] 34.3 [10.0] 2.8	55.4 [16.2] 32.7 [9.6] 2.8	53.9 [15.8] 30.5 [8.9] 2.8	53.5 [15.7] 40.9 [12.0] 2.8	52.6 [15.4] 39.1 [11.5] 2.8	51.1 [15.0] 36.4 [10.7] 2.7	50.8 [14.9] 45.7 [13.4] 2.8	49.9 [14.6] 43.7 [12.8] 2.8	48.6 [14.2] 40.6 [11.9] 2.7
	85 [29.4]	Total BTUH [kW] Sens BTUH [kW] Power	54.9 [16.1] 33.7 [9.9] 3.0	53.9 [15.8] 32.2 [9.4] 3.0	52.4 [15.4] 29.9 [8.8] 2.9	52.0 [15.2] 40.3 [11.8] 3.0	51.0 [15.0] 38.5 [11.3] 2.9	49.6 [14.5] 35.8 [10.5] 2.9	49.3 [14.4] 45.1 [13.2] 2.9	48.4 [14.2] 43.1 [12.6] 2.9	47.1 [13.8] 40.1 [11.7] 2.9
	90 [32.2]	Total BTUH [kW] Sens BTUH [kW] Power	53.3 [15.6] 33.0 [9.7] 3.1	52.3 [15.3] 31.5 [9.2] 3.1	50.9 [14.9] 29.3 [8.6] 3.1	50.4 [14.8] 39.6 [11.6] 3.1	49.5 [14.5] 37.9 [11.1] 3.1	48.1 [14.1] 35.2 [10.3] 3.1	47.7 [14.0] 44.4 [13.0] 3.1	46.9 [13.7] 42.4 [12.4] 3.1	45.6 [13.4] 39.5 [11.6] 3.0
	95 [35]	Total BTUH [kW] Sens BTUH [kW] Power	51.7 [15.1] 32.2 [9.4] 3.3	50.7 [14.9] 30.7 [9.0] 3.3	49.4 [14.5] 28.6 [8.4] 3.3	48.8 [14.3] 38.8 [11.4] 3.3	47.9 [14.0] 37.1 [10.9] 3.3	46.6 [13.7] 34.5 [10.1] 3.2	46.1 [13.5] 43.6 [12.8] 3.3	45.3 [13.3] 41.7 [12.2] 3.3	44.0 [12.9] 38.8 [11.4] 3.2
	100 [37.8]	Total BTUH [kW] Sens BTUH [kW] Power	50.0 [14.7] 31.3 [9.2] 3.5	49.1 [14.4] 29.9 [8.8] 3.5	47.8 [14.0] 27.8 [8.1] 3.4	47.1 [13.8] 37.9 [11.1] 3.5	46.3 [13.6] 36.3 [10.6] 3.5	45.0 [13.2] 33.7 [9.9] 3.4	44.4 [13.0] 42.7 [12.5] 3.5	43.6 [12.8] 40.8 [12.0] 3.5	42.4 [12.4] 38.0 [11.1] 3.4
	105 [40.6]	Total BTUH [kW] Sens BTUH [kW] Power	48.3 [14.2] 30.3 [8.9] 3.7	47.4 [13.9] 29.0 [8.5] 3.7	46.1 [13.5] 26.9 [7.9] 3.7	45.4 [13.3] 37.0 [10.8] 3.7	44.6 [13.1] 35.3 [10.3] 3.7	43.4 [12.7] 32.8 [9.6] 3.6	42.7 [12.5] 41.8 [12.2] 3.7	42.0 [12.3] 39.9 [11.7] 3.7	40.8 [12.0] 37.1 [10.9] 3.6
	110 [43.3]	Total BTUH [kW] Sens BTUH [kW] Power	46.6 [13.6] 29.2 [8.6] 4.0	45.7 [13.4] 27.9 [8.2] 3.9	44.5 [13.0] 26.0 [7.6] 3.9	43.7 [12.8] 35.9 [10.5] 3.9	42.9 [12.6] 34.3 [10.0] 3.9	41.7 [12.2] 31.9 [9.3] 3.9	41.0 [12.0] 40.7 [11.9] 3.9	40.2 [11.8] 38.9 [11.4] 3.9	39.1 [11.5] 36.1 [10.6] 3.8
	115 [46.1]	Total BTUH [kW] Sens BTUH [kW] Power	44.8 [13.1] 28.1 [8.2] 4.2	44.0 [12.9] 26.8 [7.9] 4.2	42.8 [12.5] 24.9 [7.3] 4.1	41.9 [12.3] 34.7 [10.2] 4.2	41.1 [12.0] 33.2 [9.7] 4.2	40.0 [11.7] 30.8 [9.0] 4.1	39.2 [11.5] 39.2 [11.5] 4.2	38.5 [11.3] 37.8 [11.1] 4.1	37.4 [11.0] 35.1 [10.3] 4.1
	120 [48.9]	Total BTUH [kW] Sens BTUH [kW] Power	42.9 [12.6] 26.8 [7.9] 4.5	42.2 [12.4] 25.6 [7.5] 4.4	41.0 [12.0] 23.8 [7.0] 4.4	40.0 [11.7] 33.5 [9.8] 4.4	39.3 [11.5] 32.0 [9.4] 4.4	38.2 [11.2] 29.7 [8.7] 4.3	37.4 [10.9] 37.4 [10.9] 4.4	36.7 [10.8] 36.5 [10.7] 4.4	35.7 [10.5] 34.0 [10.0] 4.3
125 [51.7]	Total BTUH [kW] Sens BTUH [kW] Power	41.1 [12.0] 25.4 [7.5] 4.7	40.3 [11.8] 24.3 [7.1] 4.7	39.2 [11.5] 22.6 [6.6] 4.6	38.2 [11.2] 32.1 [9.4] 4.7	37.5 [11.0] 30.7 [9.0] 4.7	36.5 [10.7] 28.5 [8.4] 4.6	35.5 [10.4] 35.5 [10.4] 4.7	34.8 [10.2] 34.8 [10.2] 4.7	33.9 [9.9] 32.8 [9.6] 4.6	

DR —Depression ratio
dbE —Entering air dry bulb
wbE—Entering air wet bulb

Total —Total capacity x 1000 BTUH
Sens —Sensible capacity x 1000 BTUH
Power—kW input

NOTES: ① When the entering air dry bulb is other than 80°F [27°C], adjust the sensible capacity from the table by adding [1.10 x CFM x (1 – DR) x (dbE – 80)].

[] Designates Metric Conversions





GROSS SYSTEMS PERFORMANCE DATA—RKQN-A060

ENTERING INDOOR AIR @ 80°F [26.7°C] dbE ①											
wbE		71°F [21.7°C]			67°F [19.4°C]			63°F [17.2°C]			
CFM [L/s]		1980 [934]	1800 [850]	1530 [722]	1980 [934]	1800 [850]	1530 [722]	1980 [934]	1800 [850]	1530 [722]	
DR ①		0.14	0.13	0.1	0.14	0.13	0.1	0.14	0.13	0.1	
OUTDOOR DRY BULB TEMPERATURE °F [°C]	75 [23.9]	Total BTUH [kW]	70.3 [20.6]	69.0 [20.2]	67.1 [19.7]	66.2 [19.4]	65.0 [19.0]	63.2 [18.5]	62.2 [18.2]	61.0 [17.9]	59.4 [17.4]
		Sens BTUH [kW]	40.2 [11.8]	38.4 [11.3]	35.7 [10.5]	47.5 [13.9]	45.3 [13.3]	42.2 [12.4]	53.7 [15.7]	51.3 [15.0]	47.7 [14.0]
		Power	3.6	3.5	3.5	3.5	3.5	3.5	3.5	3.5	3.5
	80 [26.7]	Total BTUH [kW]	68.8 [20.2]	67.6 [19.8]	65.8 [19.3]	64.7 [19.0]	63.6 [18.6]	61.8 [18.1]	60.7 [17.8]	59.6 [17.5]	58.0 [17.0]
		Sens BTUH [kW]	39.6 [11.6]	37.9 [11.1]	35.2 [10.3]	46.8 [13.7]	44.8 [13.1]	41.6 [12.2]	53.1 [15.5]	50.7 [14.9]	47.1 [13.8]
		Power	3.8	3.7	3.7	3.7	3.7	3.6	3.7	3.6	3.6
	85 [29.4]	Total BTUH [kW]	67.3 [19.7]	66.1 [19.4]	64.3 [18.8]	63.2 [18.5]	62.1 [18.2]	60.4 [17.7]	59.2 [17.3]	58.1 [17.0]	56.5 [16.6]
		Sens BTUH [kW]	38.9 [11.4]	37.2 [10.9]	34.6 [10.1]	46.2 [13.5]	44.1 [12.9]	41.0 [12.0]	52.4 [15.3]	50.0 [14.7]	46.5 [13.6]
		Power	3.9	3.9	3.9	3.9	3.9	3.8	3.9	3.8	3.8
	90 [32.2]	Total BTUH [kW]	65.7 [19.2]	64.5 [18.9]	62.7 [18.4]	61.6 [18.0]	60.5 [17.7]	58.8 [17.2]	57.6 [16.9]	56.5 [16.6]	55.0 [16.1]
Sens BTUH [kW]		38.2 [11.2]	36.5 [10.7]	33.9 [9.9]	45.4 [13.3]	43.4 [12.7]	40.3 [11.8]	51.6 [15.1]	49.3 [14.4]	45.9 [13.4]	
Power		4.2	4.1	4.1	4.1	4.1	4.0	4.1	4.0	4.0	
95 [35]	Total BTUH [kW]	64.0 [18.7]	62.8 [18.4]	61.1 [17.9]	59.8 [17.5]	58.8 [17.2]	57.2 [16.8]	55.8 [16.4]	54.8 [16.1]	53.3 [15.6]	
	Sens BTUH [kW]	37.3 [10.9]	35.7 [10.5]	33.2 [9.7]	44.6 [13.1]	42.6 [12.5]	39.6 [11.6]	50.8 [14.9]	48.5 [14.2]	45.1 [13.2]	
	Power	4.4	4.4	4.3	4.3	4.3	4.3	4.3	4.3	4.2	
100 [37.8]	Total BTUH [kW]	62.1 [18.2]	61.0 [17.9]	59.4 [17.4]	58.0 [17.0]	57.0 [16.7]	55.4 [16.2]	54.0 [15.8]	53.0 [15.5]	51.6 [15.1]	
	Sens BTUH [kW]	36.4 [10.7]	34.8 [10.2]	32.4 [9.5]	43.6 [12.8]	41.7 [12.2]	38.8 [11.4]	49.9 [14.6]	47.6 [14.0]	44.3 [13.0]	
	Power	4.6	4.6	4.5	4.6	4.6	4.5	4.6	4.5	4.5	
105 [40.6]	Total BTUH [kW]	60.2 [17.6]	59.2 [17.3]	57.5 [16.9]	56.1 [16.4]	55.1 [16.2]	53.6 [15.7]	52.1 [15.3]	51.2 [15.0]	49.8 [14.6]	
	Sens BTUH [kW]	35.4 [10.4]	33.8 [9.9]	31.5 [9.2]	42.6 [12.5]	40.7 [11.9]	37.9 [11.1]	48.9 [14.3]	46.7 [13.7]	43.4 [12.7]	
	Power	4.9	4.9	4.8	4.9	4.8	4.8	4.8	4.8	4.7	
110 [43.3]	Total BTUH [kW]	58.2 [17.1]	57.2 [16.8]	55.6 [16.3]	54.1 [15.9]	53.1 [15.6]	51.7 [15.1]	50.1 [14.7]	49.2 [14.4]	47.9 [14.0]	
	Sens BTUH [kW]	34.3 [10.1]	32.8 [9.6]	30.5 [8.9]	41.6 [12.2]	39.7 [11.6]	36.9 [10.8]	47.8 [14.0]	45.7 [13.4]	42.5 [12.4]	
	Power	5.2	5.2	5.1	5.2	5.1	5.0	5.1	5.1	5.0	
115 [46.1]	Total BTUH [kW]	56.1 [16.4]	55.1 [16.2]	53.6 [15.7]	52.0 [15.2]	51.1 [15.0]	49.7 [14.6]	48.0 [14.1]	47.1 [13.8]	45.9 [13.4]	
	Sens BTUH [kW]	33.2 [9.7]	31.7 [9.3]	29.5 [8.6]	40.4 [11.8]	38.6 [11.3]	35.9 [10.5]	46.6 [13.7]	44.6 [13.1]	41.4 [12.1]	
	Power	5.5	5.5	5.4	5.5	5.4	5.3	5.4	5.4	5.3	
120 [48.9]	Total BTUH [kW]	53.9 [15.8]	53.0 [15.5]	51.5 [15.1]	49.8 [14.6]	48.9 [14.3]	47.6 [13.9]	45.8 [13.4]	45.0 [13.2]	43.8 [12.8]	
	Sens BTUH [kW]	32.0 [9.4]	30.5 [9.0]	28.4 [8.3]	39.2 [11.5]	37.5 [11.0]	34.8 [10.2]	45.4 [13.3]	43.4 [12.7]	40.3 [11.8]	
	Power	5.8	5.8	5.7	5.8	5.7	5.7	5.7	5.7	5.6	
125 [51.7]	Total BTUH [kW]	51.6 [15.1]	50.7 [14.9]	49.3 [14.5]	47.5 [13.9]	46.7 [13.7]	45.4 [13.3]	43.5 [12.8]	42.7 [12.5]	41.6 [12.2]	
	Sens BTUH [kW]	30.7 [9.0]	29.3 [8.6]	27.2 [8.0]	37.9 [11.1]	36.2 [10.6]	33.7 [9.9]	43.5 [12.8]	42.1 [12.3]	39.2 [11.5]	
	Power	6.2	6.1	6.0	6.1	6.1	6.0	6.1	6.0	5.9	

DR —Depression ratio
dbE —Entering air dry bulb
wbE—Entering air wet bulb

Total —Total capacity x 1000 BTUH
Sens —Sensible capacity x 1000 BTUH
Power —kW input

NOTES: ① When the entering air dry bulb is other than 80°F [27°C], adjust the sensible capacity from the table by adding [1.10 x CFM x (1 - DR) x (dbE - 80)].

[] Designates Metric Conversions



DIRECT-DRIVE 208 AIRFLOW PERFORMANCE

		CFM [L/s] Air Delivery/RPM/Watts-208/230/460 Volts																
		External Static Pressure—Inches W.C. [kPa]																
		0.1 [0.02]	0.2 [0.05]	0.3 [0.07]	0.4 [0.10]	0.5 [0.12]	0.6 [0.15]	0.7 [0.17]	0.8 [0.20]	0.9 [0.22]	1.0 [0.25]	1.1 [0.27]	1.2 [0.30]	1.3 [0.32]	1.4 [0.35]	1.5 [0.37]		
5-TON 15 SEER 2-STAGE CV & DV MODELS	1st Stage Cooling	FACTORY SETTING	CFM	1393	1418	1443	1463	1470	1448	1456	1463	1415	1403	1341	1289	1265	1229	
			RPM	610	688	754	800	873	940	1026	1080	1130	1160	1186	1213	1254	1292	
			Watts	215	266	314	350	409	466	515	550	599	653	683	710	742	791	835
		OPTIONAL	CFM	1579	1599	1626	1642	1647	1642	1648	1648	1651	1644	1633	1570	1523	1499	1397
			RPM	676	734	793	850	903	952	1004	1054	1095	1139	1186	1225	1265	1297	1321
			Watts	302	349	404	454	508	560	614	670	717	772	836	885	942	988	989
	2nd Stage Cooling	FACTORY SETTING	CFM	1758	1784	1796	1801	1820	1825	1826	1834	1832	1830	1817	1795	1682	1561	
			RPM	722	782	836	874	932	971	1022	1065	1114	1150	1189	1231	1273	1319	1348
			Watts	392	451	508	547	615	664	728	786	854	908	968	1036	1106	1147	1127
		OPTIONAL	CFM	2075	2087	2088	2085	2090	2101	2106	2106	2114	2105	2101	2001	1943	1855	1628
			RPM	798	843	897	936	981	1018	1057	1096	1136	1170	1203	1241	1272	1309	1349
			Watts	590	646	714	769	835	890	953	1014	1082	1137	1167	1193	1220	1241	1186
OPTIONAL	CFM	2222	2220	2239	2244	2261	2236	2216	2180	2146	2110	2051	2010	1958	1863	1636		
	RPM	841	883	933	971	1008	1046	1075	1106	1141	1173	1207	1238	1273	1312	1351		
	Watts	717	777	856	921	984	1037	1054	1083	1115	1143	1176	1201	1233	1250	1195		

[J] Designates Metric Conversions

DIRECT-DRIVE 208 AIRFLOW PERFORMANCE

Unit Model	Motor Speed From Factory		Heating Input BTU/hr [kW]	Manufacturer Recommended Air-Flow Range (Min/Max) CFM	Blower Size/ Motor HP [w] # of Speeds	Motor Speed	CFM [L/s] Air Delivery/RPM/Watts-230/460 Volts								
	Cool	Heat					External Static Pressure—Inches W.C. [kPa]								
							0.1 [.02]	0.2 [.05]	0.3 [.07]	0.4 [.10]	0.5 [.12]	0.6 [.15]	0.7 [.17]	0.8 [.20]	
RKNN-A036	Low	Med	80,000 [23.45]	1050/1350	10x10 1/2 HP [373] 3 Speed Motor (PSC Motor)	Low	CFM	1153	1155	1150	1106	1043	977	809	645
			Watts				519	503	485	453	418	393	345	289	
			CFM				1296	1303	1290	1269	1212	1143	1015	773	
RKNN-A048	Med	High	120,000 [35.17]	1400/1800	10x10 1/2 HP [373] 3 Speed Motor (PSC Motor)	Med	CFM	594	581	560	539	510	470	432	369
			Watts				1661	1640	1605	1550	1479	1368	1259	943	
			CFM				778	748	708	671	630	570	530	436	
RKNN-A060	Med	High	80,000 [23.45]	1750/2250	10x10 1 HP [745] 3 Speed Motor (PSC Motor)	Low	CFM	1160	1164	1159	1132	1097	1013	913	702
			Watts				521	503	489	469	444	402	372	300	
			CFM				1302	1299	1290	1268	1216	1144	1083	901	
RKNN-A060	Med	High	100,000 [29.31]	1750/2250	10x10 1 HP [745] 3 Speed Motor (PSC Motor)	Med	CFM	576	562	544	525	497	458	434	378
			Watts				1667	1651	1616	1569	1517	1441	1371	1153	
			CFM				782	751	713	680	644	597	564	485	
RKNN-A060	Med	High	135,000 [39.56]	1750/2250	10x10 1 HP [745] 3 Speed Motor (PSC Motor)	High	CFM	1425	1414	1402	1383	1339	1272	1150	1005
			Watts				580	568	555	536	513	479	442	404	
			CFM				1706	1695	1672	1633	1593	1519	1410	1161	
RKNN-A060	Med	High	100,000 [29.31]	1750/2250	10x10 1 HP [745] 3 Speed Motor (PSC Motor)	Med	CFM	717	698	682	655	630	593	546	476
			Watts				2377	2293	2215	2114	2030	1909	1757	1566	
			CFM				1086	1036	993	947	911	859	800	735	

[] Designates Metric Conversions

DIRECT-DRIVE 230/460 AIRFLOW PERFORMANCE

Unit Model	Motor Speed From Factory		Heating Input BTU/hr [kW]	Manufacturer Recommended Air-Flow Range (Min/Max) CFM	Blower Size/ Motor HP [w] # of Speeds	Motor Speed	CFM [L/s] Air Delivery/RPM/Watts-230/460 Volts									
	Cool	Heat					External Static Pressure—Inches W.C. [kPa]									
							0.1 [.02]	0.2 [.05]	0.3 [.07]	0.4 [.10]	0.5 [.12]	0.6 [.15]	0.7 [.17]	0.8 [.20]		
RKNN-A036	Low	Low	80,000 [23.45]	1050/1350	10x10 1/2 HP [373] 3 Speed Motor (PSC Motor)	Low	CFM	1346	1329	1287	1212	1157	969	838		
		Watts	596				557	523	483	463	401	371				
		Med	120,000 [35.17]				CFM	1496	1474	1442	1391	1323	1139	932		
RKNN-A048	Med	High	135,000 [39.56]	1400/1800	10x10 1/2 HP [373] 3 Speed Motor (PSC Motor)	Med	CFM	677	656	606	576	536	488	442		
		Watts	1875				1846	1798	1740	1679	1602	1464	1268			
		Low	80,000 [23.45]				CFM	1355	1340	1318	1275	1200	1094	912		
RKNN-A060	Med	High	135,000 [39.56]	1750/2250	10x10 1 HP [745] 3 Speed Motor (PSC Motor)	High	CFM	874	805	765	729	688	629	559		
		Watts	1875				1846	1798	1740	1679	1602	1464	1268			
		Low	100,000 [29.31]				CFM	1649	1609	1580	1528	1461	1319	1112		
RKNN-A060	Med	High	135,000 [39.56]	1750/2250	10x10 1 HP [745] 3 Speed Motor (PSC Motor)	High	CFM	829	776	742	705	658	618	544		
		Watts	1177				1133	1087	1046	963	842	714	587			
		Low	100,000 [29.31]				CFM	1952	1880	1816	1746	1647	1546	1309		
RKNN-A060	Med	High	135,000 [39.56]	1750/2250	10x10 1 HP [745] 3 Speed Motor (PSC Motor)	High	CFM	2471	2279	2177	2066	1973	1802	1614		
		Watts	1177				1133	1087	1046	963	842	714	587			
		Low	100,000 [29.31]				CFM	679	646	623	593	560	512	457		
RKNN-A060	Med	High	135,000 [39.56]	1750/2250	10x10 1 HP [745] 3 Speed Motor (PSC Motor)	High	CFM	829	776	742	705	658	618	544		
		Watts	1177				1133	1087	1046	963	842	714	587			
		Low	100,000 [29.31]				CFM	1952	1880	1816	1746	1647	1546	1309		

[] Designates Metric Conversions

DIRECT-DRIVE 208 AIRFLOW PERFORMANCE

Unit Model	Motor Speed From Factory		Heating Input BTU/hr [kW]	Manufacturer Recommended Air-Flow Range (Min/Max) CFM	Blower Size/ Motor HP (w) # of Speeds	Motor Speed	CFM [L/s] Air Delivery/RPM/Watts-230/460 Volts							
							External Static Pressure—Inches W.C. [kPa]							
	Cool	Heat					0.1 [.02]	0.2 [.05]	0.3 [.07]	0.4 [.10]	0.5 [.12]	0.6 [.15]	0.7 [.17]	0.8 [.20]
RKPN-A036		Low	80,000 [23.45]	1050/1350	10x10 1/2 HP [373] 3 Speed Motor (PSC Motor)	Low	CFM	1153	1150	1106	1043	977	809	645
		Med	120,000 [35.17]			Watts	519	503	485	453	418	393	345	289
	Low					CFM	1296	1303	1290	1269	1212	1143	1015	773
RKPN-A048		Med		1400/1800	10x10 1/2 HP [373] 3 Speed Motor (PSC Motor)	Med	CFM	594	581	539	510	470	432	369
		High	135,000 [39.56]			Watts	1661	1640	1605	1550	1479	1368	1259	943
	Med					CFM	778	748	708	671	630	570	530	436
RKPN-A060		Low	80,000 [23.45]	1750/2250	10x10 1 HP [745] 3 Speed Motor (PSC Motor)	Low	CFM	1160	1164	1132	1097	1013	913	702
		Med	100,000 [29.31]			Watts	521	503	489	469	444	402	372	300
	Low					CFM	1302	1299	1290	1268	1216	1144	1083	901
RKPN-A060		High	135,000 [39.56]	1750/2250	10x10 1 HP [745] 3 Speed Motor (PSC Motor)	High	CFM	576	562	525	497	458	434	378
		Med	100,000 [29.31]			Watts	1667	1651	1616	1569	1517	1441	1371	1153
	Med					CFM	782	751	713	680	644	597	564	485
RKPN-A060		Low	100,000 [29.31]	1750/2250	10x10 1 HP [745] 3 Speed Motor (PSC Motor)	Low	CFM	1678	1641	1557	1521	1471	1430	1384
		High	135,000 [39.56]			Watts	354	364	386	409	430	456	470	491
	Med					CFM	1842	1820	1781	1741	1703	1659	1613	1536
RKPN-A060		High	135,000 [39.56]	1750/2250	10x10 1 HP [745] 3 Speed Motor (PSC Motor)	High	CFM	455	479	516	529	551	574	571
		Med	100,000 [29.31]			Watts	2476	2417	2336	2229	2120	1965	1816	1625
	Med					CFM	1010	989	977	918	862	781	707	620

[] Designates Metric Conversions

DIRECT-DRIVE 230/460 AIRFLOW PERFORMANCE

Unit Model	Motor Speed From Factory		Heating Input BTU/hr [kW]	Manufacturer Recommended Air-Flow Range (Min/Max) CFM	Blower Size/ Motor HP [w] # of Speeds	Motor Speed	CFM [L/s] Air Delivery/RPM/Watts-230/460 Volts									
	Cool	Heat					External Static Pressure—Inches W.C. [kPa]									
							0.1 [.02]	0.2 [.05]	0.3 [.07]	0.4 [.10]	0.5 [.12]	0.6 [.15]	0.7 [.17]	0.8 [.20]		
RKPN-A036	Low	Low	80,000 [23.45]	1050/1350	10x10 1/2 HP [373] 3 Speed Motor (PSC Motor)	Low	CFM	1346	1329	1287	1212	1157	969	838		
		Watts	596				557	523	483	463	401	371				
		Med	120,000 [35.17]				1496	1474	1442	1391	1323	1139	932			
RKPN-A048	Med	High	135,000 [39.56]	1400/1800	10x10 1/2 HP [373] 3 Speed Motor (PSC Motor)	Med	CFM	677	653	606	576	536	488	442		
		Watts	1875				1798	1740	1679	1602	1464	1288				
		High	100,000 [29.31]				1504	1474	1440	1396	1324	1215	1087			
RKPN-A060	Med	Low	100,000 [29.31]	1750/2250	10x10 1 HP [745] 3 Speed Motor (X-13 Motor)	Low	CFM	1678	1599	1557	1521	1471	1430	1384		
		Watts	354				386	409	430	456	470	491				
		High	135,000 [39.56]				1842	1781	1741	1703	1659	1613	1536			
		High	135,000 [39.56]			High	CFM	2476	2336	2229	2120	1965	1816	1625		
							Watts	1010	989	977	862	781	707	620		

[] Designates Metric Conversions

DIRECT-DRIVE 208/230/460 AIRFLOW PERFORMANCE

Unit Model	Motor Speed From Factory		Heating Input BTU/hr [kW]	Manufacturer Recommended Air-Flow Range (Min/Max) CFM	Blower Size/ Motor HP [w] # of Speeds	Motor Speed	CFM [L/s] Air Delivery/RPM/Watts-230/460 Volts									
	Cool	Heat					External Static Pressure—Inches W.C. [kPa]									
							0.1 [0.02]	0.2 [0.05]	0.3 [0.07]	0.4 [0.10]	0.5 [0.12]	0.6 [0.15]	0.7 [0.17]	0.8 [0.20]		
RKQN-A036	Low (Tap 2)	Med. (Tap 3)	80,000 [23.45]	1050/1350	10x10 1/2 HP [373] 3 Speed Motor (X-13 Motor)	Low (Tap 2)	CFM	1345	1302	1260	1220	1178	1122	1076	979	
							Watts	215	230	245	260	274	284	303	320	
							CFM	1438	1398	1360	1322	1284	1245	1200	1137	
							Watts	261	276	291	306	320	334	348	362	
RKQN-A048	Med (Tap 2)	High (Tap 4)	120,000 [35.17]	1400/1800	10x10 3/4 HP [559] 4 Speed Motor (X-13 Motor)	Med. (Tap 3)	CFM	1614	1576	1538	1504	1463	1425	1388	1349	
							Watts	360	382	398	411	427	441	454	466	
							CFM	1403	1345	1310	1269	1212	1164	1083	1028	
							Watts	232	244	255	267	283	297	315	324	
RKQN-A060	Low Cool (Tap 1) High Cool (Tap 3)	Med. (Tap 3)	100,000 [29.31]	1400/1800	10x10 1 HP [745] 5 Speed Motor (X-13 Motor)	Med. (Tap 3)	CFM	1677	1639	1597	1559	1522	1487	1432	1390	
							Watts	354	367	382	396	412	425	442	459	
							CFM	1795	1758	1718	1688	1645	1607	1571	1535	
							Watts	429	445	459	473	493	508	525	541	
RKQN-A060	Low Cool (Tap 1) High Cool (Tap 3)	High (Tap 3)	135,000 [39.56]	1st Stage Cool 1350/1400 2nd Stage Cool 1750/2250	10x10 1 HP [745] 5 Speed Motor (X-13 Motor)	Low Cool (Tap 1)	CFM	1404	1369	1326	1265	1221	1166	1107	1043	
							Watts	233	250	270	280	300	319	340	344	
							CFM	1678	1641	1599	1557	1521	1471	1430	1384	
							Watts	354	364	386	409	430	456	470	491	
RKQN-A060	Low Cool (Tap 1) High Cool (Tap 3)	High (Tap 3)	135,000 [39.56]	1st Stage Cool 1350/1400 2nd Stage Cool 1750/2250	10x10 1 HP [745] 5 Speed Motor (X-13 Motor)	Med. (Tap 3)	CFM	1842	1820	1781	1741	1703	1659	1613	1536	
							Watts	455	479	489	516	529	551	574	571	
							CFM	1842	1820	1781	1741	1703	1659	1613	1536	
							Watts	455	479	489	516	529	551	574	571	
RKQN-A060	Low Cool (Tap 1) High Cool (Tap 3)	High (Tap 3)	135,000 [39.56]	1st Stage Cool 1350/1400 2nd Stage Cool 1750/2250	10x10 1 HP [745] 5 Speed Motor (X-13 Motor)	High (Tap 3)	CFM	2476	2417	2336	2229	2120	1965	1816	1625	
							Watts	1010	989	977	918	862	781	707	620	

[] Designates Metric Conversions

AIRFLOW PERFORMANCE—3 TON [10.55 kW] 3 PHASE BELT DRIVE

Capacity 3 Ton [10.55 kW] Voltage 208/230/460/575, 3-Phase

Air Flow CFM [L/s]	External Static Pressure—Inches of Water [kPa]																														
	0.1 [.02]		0.2 [.05]		0.3 [.07]		0.4 [.10]		0.5 [.12]		0.6 [.15]		0.7 [1.17]		0.8 [.20]		0.9 [.22]		1.0 [.25]		1.1 [.27]		1.2 [.30]		1.3 [.32]		1.4 [.35]		1.5 [.37]		
	RPM	W	RPM	W	RPM	W	RPM	W	RPM	W	RPM	W	RPM	W	RPM	W	RPM	W	RPM	W	RPM	W	RPM	W	RPM	W	RPM	W	RPM	W	RPM
900 [425]	—	—	—	—	699	223	765	261	827	292	886	318	941	338	993	352	1042	360	1087	362	1129	358	1168	348	1203	332	1235	310	1264	282	
1000 [472]	—	—	662	228	717	258	781	293	842	323	899	346	952	364	1002	376	1049	381	1093	381	1133	374	1170	362	1203	344	1233	320	1260	289	
1100 [519]	—	—	667	275	737	295	798	328	857	355	912	377	964	392	1012	401	1057	404	1099	402	1137	393	1172	378	1204	358	1232	331	1257	298	
1200 [566]	643	278	693	298	756	334	817	365	873	390	927	409	976	422	1023	428	1066	429	1106	424	1143	413	1176	396	1205	373	1232	344	1255	309	
1300 [614]	661	316	716	341	777	376	835	404	890	426	942	443	990	453	1035	458	1076	456	1114	449	1149	435	1180	416	1208	391	1232	359	1254	322	
1400 [661]	669	352	739	387	799	419	855	445	908	465	958	479	1004	487	1047	489	1087	485	1123	475	1156	460	1185	438	1211	410	1234	377	1253	337	
1500 [708]	702	399	763	434	821	464	876	487	927	505	975	517	1019	523	1060	522	1098	516	1132	504	1163	486	1191	462	1215	432	1236	396	1254	354	

NOTE: L-Drive left of bold line, M-Drive right of bold line.

Drive Package	L		M	
Motor H.P. [W]	1/2 [373]		1/2 [373]	
Blower Sheave	6.9" Pitch Diameter		6.4" Pitch Diameter	
Motor Sheave	2.4" - 3.4" Pitch Diameter		3.4" - 4.4" Pitch Diameter	
Turns Open	0	1	2	3
RPM	910	869	818	775
			728	682
			1176	1145
			1108	1060
			966	968

COMPONENT AIR RESISTANCE

CFM [L/s]	Standard Indoor Airflow—CFM [L/s]			
	1000 [472]	1400 [661]	1600 [755]	2000 [944]
Resistance—Inches Water [kPa]				
Wet Coil	0.035	0.040	0.060	0.100
Downflow	0.055	0.060	0.072	0.086
R.S.I. Economizer R.A. Damper	0.05	0.06	0.07	0.10

- NOTES:**
- Performance shown with dry coil & standard 2" [50.8 mm] filters.
 - Standard CFM @ .075 lbs./cu. ft.
 - Motor efficiency = 80%
 - BHP = $\frac{\text{Watts} \times \text{Motor Eff.}}{746}$
 - Add component resistance to duct static to determine E.S.P. as shown on charts.

[] Designates Metric Conversions

AIRFLOW PERFORMANCE—4 TON [14.07 kW] 3 PHASE BELT DRIVE

Capacity 4 Ton [14.07 kW] Voltage 208/230/460/575, 3-Phase

Air Flow CFM [L/s]	External Static Pressure—Inches of Water [kPa]														
	0.1 [0.02]	0.2 [0.05]	0.3 [0.07]	0.4 [0.10]	0.5 [0.12]	0.6 [0.15]	0.7 [0.17]	0.8 [0.20]	0.9 [0.22]	1.0 [0.25]	1.1 [0.27]	1.2 [0.30]	1.3 [0.32]	1.4 [0.35]	1.5 [0.37]
1200 [566]	—	—	—	—	—	—	—	—	—	—	—	—	—	—	—
1300 [614]	—	—	—	817	425	879	440	456	989	475	1057	496	1113	519	1168
1400 [661]	—	—	—	838	437	899	457	958	1015	503	1071	529	1126	558	1178
1500 [708]	—	—	—	806	418	861	457	919	482	539	1086	571	1138	605	1189
1600 [755]	—	—	—	825	458	883	486	940	517	995	549	1048	584	1101	1200
1700 [802]	—	—	798	449	849	490	905	523	960	559	1013	598	1065	638	1115
1800 [850]	791	490	844	537	898	579	950	624	1002	670	1051	719	1099	771	1146
1900 [897]	816	543	870	589	923	637	973	687	1023	739	1070	793	1116	850	1161
2000 [944]	845	599	897	650	947	703	996	758	1044	816	1089	875	1134	937	1176

NOTE: L-Drive left of bold line, M-Drive right of bold line.

Drive Package	L					M					N Drive (Field Supplied)				
Motor H.P. [W]	1/2 [373]					3/4 [559]					3/4 [559]				
Blower Sheave	6.9" Pitch Diameter					6.4" Pitch Diameter					6.4" Pitch Diameter				
Motor Sheave	2.8" - 3.8" Pitch Diameter					3.4" - 4.4" Pitch Diameter					4.0" - 5.0" Pitch Diameter				
Turns Open	0	1	2	3	4	5	6	1	2	3	4	5	1111	1071	1071
RPM	1029	984	950	915	855	816	1281	1207	1174	1141	1111	1071	1332	1280	1355

COMPONENT AIR RESISTANCE

CFM [L/s]	Standard Indoor Airflow—CFM [L/s]			Resistance—Inches Water [kPa]		
	1000 [472]	1400 [661]	1600 [755]	1800 [850]	2000 [944]	2000 [944]
Wet Coil	0.035	0.040	0.060	0.070	0.085	0.100
Downflow	0.055	0.060	0.066	0.072	0.080	0.086
R.S.I. Economizer R.A. Damper	0.05	0.06	0.07	0.08	0.09	0.10

NOTES:

- Performance shown with dry coil & standard 2" [50.8 mm] filters.
- Standard CFM @ .075 lbs./cu. ft.
- Motor efficiency = 80%
- BHP = $\frac{\text{Watts} \times \text{Motor Eff.}}{746}$
- Add component resistance to duct static to determine E.S.P. as shown on charts.

[] Designates Metric Conversions

AIRFLOW PERFORMANCE—5 TON [10.55 kW] 3 PHASE BELT DRIVE

Air Flow CFM [L/s]	Capacity 5 Ton [17.6 kW] - 13 SEER Voltage 208/230/460/575, 3-Phase																													
	External Static Pressure—Inches of Water [kPa]																													
	0.1 [.02]	0.2 [.05]	0.3 [.07]	0.4 [.10]	0.5 [.12]	0.6 [.15]	0.7 [.17]	0.8 [.20]	0.9 [.22]	1.0 [.25]	1.1 [.27]	1.2 [.30]	1.3 [.32]	1.4 [.35]	1.5 [.37]															
RPM	W	RPM	W	RPM	W	RPM	W	RPM	W	RPM	W	RPM	W	RPM	W	RPM	W	RPM	W	RPM	W	RPM	W	RPM	W	RPM	W	RPM	W	
1400 [661]	—	—	795	405	848	423	910	466	970	511	1029	557	1086	606	1142	655	1196	706	1249	758	1300	812	1350	868	1398	925	1438	965	—	—
1500 [708]	—	—	809	413	871	458	931	504	989	552	1046	602	1100	654	1155	705	1208	759	1259	815	1308	872	1356	930	1457	1125	1558	1320	—	—
1600 [755]	—	—	796	430	835	454	894	502	952	551	1009	602	1064	655	1118	709	1170	764	1220	821	1270	880	1317	940	1363	1001	1451	1212	1539	1423
1700 [802]	—	—	811	470	861	504	919	555	975	607	1030	661	1079	708	1135	773	1185	832	1234	892	1281	953	1327	1017	1371	1081	1442	1307	1513	1533
1800 [850]	792	485	831	510	888	563	944	616	999	672	1051	729	1094	760	1153	847	1201	908	1248	971	1293	1036	1337	1102	1380	1170	1440	1410	1500	1650
1900 [897]	804	521	861	575	916	630	970	686	1023	745	1074	805	1123	866	1171	929	1218	994	1263	1060	1307	1127	1349	1196	1389	1267	1443	1534	1497	1801
2000 [944]	836	591	891	647	945	706	997	765	1048	827	1098	894	1145	954	1191	1020	1236	1087	1279	1156	1320	1227	1361	1299	1399	1373	1437	1447	—	—
2100 [991]	870	669	923	729	975	790	1025	853	1074	917	1121	983	1167	1050	1211	1119	1254	1190	1295	1262	1335	1336	1411	1410	1486	1446	1561	—	—	—
2200 [1038]	904	756	955	819	1005	883	1054	949	1101	1021	1146	1085	1190	1156	1232	1228	1273	1301	1313	1376	1351	1453	1387	1531	1422	1609	—	—	—	—
2300 [1085]	939	852	988	918	1036	985	1084	1058	1128	1124	1172	1196	1214	1270	1254	1345	1294	1421	1331	1499	1367	1579	1402	1615	1434	1634	—	—	—	—
2400 [1133]	975	957	1022	1025	1068	1096	1113	1167	1156	1241	1198	1316	1238	1392	1277	1470	1315	1550	1350	1631	1385	1713	1420	1748	—	—	—	—	—	—
2500 [1179]	1011	1070	1057	1142	1096	1126	1144	1290	1186	1366	1226	1444	1264	1523	1301	1604	1336	1687	1370	1771	—	—	—	—	—	—	—	—	—	—

NOTE: L-Drive left of bold line, M-Drive right of bold line.

Drive Package	L	M	N Drive (Field Supplied)
Motor H.P. [W]	3/4 [559]	1 [746]	1 [746]
Blower Sheave	6.9" Pitch Diameter	6.9" Pitch Diameter	5.7" Pitch Diameter
Motor Sheave	2.8" - 3.8" Pitch Diameter	4.0" - 5.0" Pitch Diameter	4.0" - 5.0" Pitch Diameter
Turns Open	0	1	2
RPM	1025	992	945
			909
			867
			810
			1353
			1305
			1258
			1223
			1167
			1130

COMPONENT AIR RESISTANCE

CFM [L/s]	Standard Indoor Airflow—CFM [L/s]			Resistance—Inches Water [kPa]		
	1600 [755]	2000 [944]	2400 [1133]	0.070	0.085	0.100
Wet Coil				0.070	0.085	0.100
Downflow				0.072	0.080	0.086
R.S.I. Economizer R.A. Damper				0.08	0.09	0.10
				0.11	0.12	0.13

- NOTES:**
- Performance shown with dry coil & standard 2" [50.8 mm] filters.
 - Standard CFM @ .075 lbs./cu. ft.
 - Motor efficiency = 80%
 - BHP = $\frac{\text{Watts} \times \text{Motor Eff.}}{746}$
 - Add component resistance to duct static to determine E.S.P. as shown on charts.

[] Designates Metric Conversions

AIRFLOW PERFORMANCE—5 TON [10.55 kW] 3 PHASE BELT DRIVE

Air Flow CFM [L/s]		Capacity 5 Ton [17.6 kW] 14 SEER Voltage 208/230/460/575, 3-Phase																													
		External Static Pressure—Inches of Water [kPa]																													
		0.1 [0.02]		0.2 [0.05]		0.3 [0.07]		0.4 [0.10]		0.5 [0.12]		0.6 [0.15]		0.7 [0.17]		0.8 [0.20]		0.9 [0.22]		1.0 [0.25]		1.1 [0.27]		1.2 [0.30]		1.3 [0.32]		1.4 [0.35]		1.5 [0.37]	
		RPM	W	RPM	W	RPM	W	RPM	W	RPM	W	RPM	W	RPM	W	RPM	W	RPM	W	RPM	W	RPM	W	RPM	W	RPM	W	RPM	W	RPM	W
1400 [661]	—	—	—	—	—	—	—	784	466	835	497	886	533	935	574	983	621	1030	674	1077	732	1122	795	1166	864	1209	939	1251	1019	1292	1104
1500 [708]	—	—	—	—	—	—	—	800	484	850	519	899	558	947	604	994	655	1040	711	1085	773	1129	841	1172	914	1214	992	1255	1076	1295	1166
1600 [755]	—	—	—	—	—	766	478	816	511	865	549	913	593	960	643	1006	698	1051	758	1095	824	1137	885	1179	972	1220	1055	1260	1143	1300	1231
1700 [802]	—	—	—	—	—	785	509	833	546	881	589	928	637	974	690	1018	749	1062	813	1105	883	1146	959	1187	1040	1227	1126	1265	1218	1303	1310
1800 [850]	—	—	755	505	804	550	851	591	898	637	943	689	988	747	1031	810	1074	878	1115	952	1156	1031	1195	1116	1234	1207	1271	1302	1308	1397	
1900 [897]	716	491	776	560	823	600	869	645	915	695	959	751	1003	812	1045	879	1066	951	1127	1029	1166	1113	1204	1202	1242	1296	1278	1396	1314	1496	
2000 [944]	745	562	797	615	843	658	889	707	933	762	976	821	1018	887	1059	958	1099	1034	1139	1116	1177	1203	1214	1296	1250	1394	1285	1498	1320	1602	
2100 [991]	773	637	819	679	864	726	908	779	951	837	993	901	1034	970	1074	1045	1113	1125	1151	1211	1188	1303	1224	1399	1259	1502	1293	1609	—	—	
2200 [1038]	797	706	842	751	886	803	929	860	971	922	1011	990	1051	1063	1090	1142	1128	1226	1165	1316	1200	1411	1235	1512	1269	1618	—	—	—	—	
2300 [1085]	822	783	865	833	908	888	950	949	990	1015	1030	1087	1069	1164	1106	1247	1143	1335	1179	1429	1213	1528	1247	1633	1279	1743	—	—	—	—	
2400 [1133]	847	870	889	924	931	983	971	1048	1011	1118	1049	1194	1087	1275	1123	1362	1159	1454	1193	1551	1227	1655	1259	1763	1291	1878	—	—	—	—	
2500 [1179]	873	966	914	1023	954	1087	994	1155	1032	1229	1069	1309	1106	1394	1141	1485	1175	1581	1209	1683	1241	1790	1272	1903	—	—	—	—	—	—	

NOTE: L-Drive left of bold line, M-Drive right of bold line.

Drive Package	L										M																		
	3/4" [559]										1" [746]																		
Motor H.P. [W]	6.9" Pitch Diameter										6.4" Pitch Diameter																		
Blower Sheave	2.8" - 3.8" Pitch Diameter										4.0" - 5.0" Pitch Diameter																		
Motor Sheave	2.8" - 3.8" Pitch Diameter										4.0" - 5.0" Pitch Diameter																		
Turns Open	0	1	2	3	4	5	0	1	2	3	4	5	0	1	2	3	4	5	0	1	2	3	4	5	0	1	2	3	
RPM	967	936	900	855	816	769	1248	1203	1163	1123	1078	1042	1042	1078	1042	1018	983	948	913	878	843	808	773	738	703	668	633	598	563

COMPONENT AIR RESISTANCE

CFM [L/s]	Standard Indoor Airflow—CFM [L/s]				Resistance—Inches Water [kPa]			
	1600 [755]	1800 [850]	2000 [944]	2400 [1133]	2200 [1038]	2400 [1133]	2600 [1227]	2600 [1227]
Wet Coil	0.070	0.085	0.100	0.110	0.110	0.120	0.125	0.125
Downflow	0.072	0.080	0.086	0.093	0.100	0.107	0.107	0.107
R.S.I. Economizer R.A. Damper	0.08	0.09	0.10	0.11	0.12	0.13	0.13	0.13

NOTES:

- Performance shown with dry coil & standard 2" [50.8 mm] filters.
- Standard CFM @ .075 lbs./cu. ft.
- Motor efficiency = 80%
- BHP = $\frac{\text{Watts} \times \text{Motor Eff.}}{746}$
- Add component resistance to duct static to determine E.S.P. as shown on charts.

[] Designates Metric Conversions

ELECTRICAL DATA – RKNN SERIES

		A036CK	A036CL	A036CM	A036DK	A036DL	A036DM	A036JK	A036YL	A036YM
Unit Information	Unit Operating Voltage Range	187-253	187-253	187-253	414-506	414-506	414-506	187-253	517-633	517-633
	Volts	208/230	208/230	208/230	460	460	460	208/230	575	575
	Minimum Circuit Ampacity	17/17	16/16	16/16	11	10	10	24/24	7	7
	Minimum Overcurrent Protection Device Size	20/20	20/20	20/20	15	15	15	30/30	15	15
	Maximum Overcurrent Protection Device Size	25/25	20/20	20/20	15	15	15	35/35	15	15
Compressor Motor	No.	1	1	1	1	1	1	1	1	1
	Volts	208/230	208/230	208/230	460	460	460	208/230	575	575
	Phase	3	3	3	3	3	3	1	3	3
	RPM	3450	3450	3450	3450	3450	3450	3450	3450	3450
	HP, Compressor 1	3	3	3	3	3	3	3	3	3
	Amps (RLA), Comp. 1	9/9	9/9	9/9	5.6	5.6	5.6	14.1/14.1	3.8	3.8
	Amps (LRA), Comp. 1	71/71	71/71	71/71	38	38	38	77/77	36.5	36.5
Condenser Motor	No.	1	1	1	1	1	1	1	1	1
	Volts	208/230	208/230	208/230	460	460	460	208/230	575	575
	Phase	1	1	1	1	1	1	1	1	1
	HP	1/3	1/3	1/3	1/3	1/3	1/3	1/3	1/3	1/3
	Amps (FLA, each)	1.5/1.5	1.5/1.5	1.5/1.5	1	1	1	1.5/1.5	0.8	0.8
	Amps (LRA, each)	3/3	3/3	3/3	1.9	1.9	1.9	3/3	1.9	1.9
Evaporator Fan	No.	1	1	1	1	1	1	1	1	1
	Volts	208/230	208/230	208/230	460	460	460	208/230	575	575
	Phase	1	3	3	1	3	3	1	3	3
	HP	1/2	1/2	1/2	1/2	1/2	1/2	1/2	3/4	3/4
	Amps (FLA, each)	4/4	2.8/2.8	2.8/2.8	2	1.4	1.4	4/4	1.3	1.3
	Amps (LRA, each)	6.7/6.7	11.3/11.3	11.3/11.3	3.6	6.2	6.2	6.7/6.7	6	6

1. Horsepower Per Compressor.

2. Amp Draw Per Motor. Multiply Value By Number of Motors to Determine Total Amps.

ELECTRICAL DATA – RKNN SERIES										
		A048CK	A048CL	A048CM	A048DK	A048DL	A048DM	A048JK	A048YL	A048YM
Unit Information	Unit Operating Voltage Range	187-253	187-253	187-253	414-506	414-506	414-506	187-253	517-633	517-633
	Volts	208/230	208/230	208/230	460	460	460	208/230	575	575
	Minimum Circuit Ampacity	22/22	21/21	22/22	11	11	11	31/31	8	8
	Minimum Overcurrent Protection Device Size	30/30	25/25	25/25	15	15	15	40/40	15	15
	Maximum Overcurrent Protection Device Size	35/35	30/30	30/30	15	15	15	50/50	15	15
Compressor Motor	No.	1	1	1	1	1	1	1	1	1
	Volts	208/230	208/230	208/230	460	460	460	208/230	575	575
	Phase	3	3	3	3	3	3	1	3	3
	RPM	3450	3450	3450	3450	3450	3450	3450	3450	3450
	HP, Compressor 1	4	4	4	4	4	4	4	4	4
	Amps (RLA), Comp. 1	13.1/13.1	13.1/13.1	13.1/13.1	6.1	6.1	6.1	19.9/19.9	4.4	4.4
	Amps (LRA), Comp. 1	83.1/83.1	83.1/83.1	83.1/83.1	41	41	41	109/109	33	33
Condenser Motor	No.	1	1	1	1	1	1	1	1	1
	Volts	208/230	208/230	208/230	460	460	460	208/230	575	575
	Phase	1	1	1	1	1	1	1	1	1
	HP	1/3	1/3	1/3	1/3	1/3	1/3	1/3	1/3	1/3
	Amps (FLA, each)	1.5/1.5	1.5/1.5	1.5/1.5	1	1	1	1.5/1.5	0.8	0.8
	Amps (LRA, each)	3/3	3/3	3/3	1.9	1.9	1.9	3/3	1.9	1.9
Evaporator Fan	No.	1	1	1	1	1	1	1	1	1
	Volts	208/230	208/230	208/230	460	460	460	208/230	575	575
	Phase	1	3	3	1	3	3	1	3	3
	HP	1/2	1/2	3/4	1/2	1/2	3/4	1/2	3/4	3/4
	Amps (FLA, each)	4/4	2.8/2.8	3.4/3.4	2	1.4	1.6	4/4	1.3	1.3
	Amps (LRA, each)	6.7/6.7	11.3/11.3	16.8/16.8	3.6	6.2	8.4	6.7/6.7	6	6

1. Horsepower Per Compressor.

2. Amp Draw Per Motor. Multiply Value By Number of Motors to Determine Total Amps.

ELECTRICAL DATA – RKNN SERIES

		A060CK	A060CL	A060CM	A060DK	A060DL	A060DM	A060JK	A060YL	A060YM
Unit Information	Unit Operating Voltage Range	187-253	187-253	187-253	414-506	414-506	414-506	187-253	517-633	517-633
	Volts	208/230	208/230	208/230	460	460	460	208/230	575	575
	Minimum Circuit Ampacity	27/27	26/26	27/27	14	13	13	40/40	10	10
	Minimum Overcurrent Protection Device Size	35/35	30/30	35/35	20	15	15	50/50	15	15
	Maximum Overcurrent Protection Device Size	40/40	40/40	40/40	20	20	20	60/60	15	15
Compressor Motor	No.	1	1	1	1	1	1	1	1	1
	Volts	208/230	208/230	208/230	460	460	460	208/230	575	575
	Phase	3	3	3	3	3	3	1	3	3
	RPM	3450	3450	3450	3450	3450	3450	3450	3450	3450
	HP, Compressor 1	5	5	5	5	5	5	5	5	5
	Amps (RLA), Comp. 1	16/16	16/16	16/16	7.8	7.8	7.8	26.4/26.4	5.7	5.7
	Amps (LRA), Comp. 1	110/110	110/110	110/110	52	52	52	134/134	39.9	39.9
Condenser Motor	No.	1	1	1	1	1	1	1	1	1
	Volts	208/230	208/230	208/230	460	460	460	208/230	575	575
	Phase	1	1	1	1	1	1	1	1	1
	HP	1/3	1/3	1/3	1/3	1/3	1/3	1/3	1/3	1/3
	Amps (FLA, each)	2.2/2.2	2.2/2.2	2.2/2.2	1	1	1	2.2/2.2	0.8	0.8
	Amps (LRA, each)	4.9/4.9	4.9/4.9	4.9/4.9	1.9	1.9	1.9	4.9/4.9	1.9	1.9
Evaporator Fan	No.	1	1	1	1	1	1	1	1	1
	Volts	208/230	208/230	208/230	460	460	460	208/230	575	575
	Phase	1	3	3	1	3	3	1	3	3
	HP	1	3/4	1	1	3/4	1	1	3/4	1
	Amps (FLA, each)	4.8/4.8	3.4/3.4	4.1/4.1	2.6	1.6	2	4.8/4.8	1.3	1.4
	Amps (LRA, each)	0/0	16.8/16.8	14.6/14.6	0	8.4	12	0/0	6	7.2

1. Horsepower Per Compressor.

2. Amp Draw Per Motor. Multiply Value By Number of Motors to Determine Total Amps.

ELECTRICAL DATA – RKPN SERIES										
		A036CK	A036CL	A036CM	A036DK	A036DL	A036DM	A036JK	A036YL	A036YM
Unit Information	Unit Operating Voltage Range	187-253	187-253	187-253	414-506	414-506	414-506	187-253	517-633	517-633
	Volts	208/230	208/230	208/230	460	460	460	208/230	575	575
	Minimum Circuit Ampacity	17/17	16/16	16/16	11	10	10	24/24	7	7
	Minimum Overcurrent Protection Device Size	20/20	20/20	20/20	15	15	15	30/30	15	15
	Maximum Overcurrent Protection Device Size	25/25	20/20	20/20	15	15	15	35/35	15	15
Compressor Motor	No.	1	1	1	1	1	1	1	1	1
	Volts	208/230	208/230	208/230	460	460	460	208/230	575	575
	Phase	3	3	3	3	3	3	1	3	3
	RPM	3450	3450	3450	3450	3450	3450	3450	3450	3450
	HP, Compressor 1	3	3	3	3	3	3	3	3	3
	Amps (RLA), Comp. 1	9/9	9/9	9/9	5.6	5.6	5.6	14.1/14.1	3.8	3.8
	Amps (LRA), Comp. 1	71/71	71/71	71/71	38	38	38	77/77	36.5	36.5
Condenser Motor	No.	1	1	1	1	1	1	1	1	1
	Volts	208/230	208/230	208/230	460	460	460	208/230	575	575
	Phase	1	1	1	1	1	1	1	1	1
	HP	1/3	1/3	1/3	1/3	1/3	1/3	1/3	1/3	1/3
	Amps (FLA, each)	1.5/1.5	1.5/1.5	1.5/1.5	1	1	1	1.5/1.5	0.8	0.8
	Amps (LRA, each)	3/3	3/3	3/3	1.9	1.9	1.9	3/3	1.9	1.9
Evaporator Fan	No.	1	1	1	1	1	1	1	1	1
	Volts	208/230	208/230	208/230	460	460	460	208/230	575	575
	Phase	1	3	3	1	3	3	1	3	3
	HP	1/2	1/2	1/2	1/2	1/2	1/2	1/2	3/4	3/4
	Amps (FLA, each)	4/4	2.8/2.8	2.8/2.8	2	1.4	1.4	4/4	1.3	1.3
	Amps (LRA, each)	6.7/6.7	11.3/11.3	11.3/11.3	3.6	6.2	6.2	6.7/6.7	6	6

1. Horsepower Per Compressor.

2. Amp Draw Per Motor. Multiply Value By Number of Motors to Determine Total Amps.

ELECTRICAL DATA – RKPN SERIES

		A048CK	A048CL	A048CM	A048DK	A048DL	A048DM	A048JK	A048YL	A048YM
Unit Information	Unit Operating Voltage Range	187-253	187-253	187-253	414-506	414-506	414-506	187-253	517-633	517-633
	Volts	208/230	208/230	208/230	460	460	460	208/230	575	575
	Minimum Circuit Ampacity	22/22	21/21	22/22	11	11	11	31/31	8	8
	Minimum Overcurrent Protection Device Size	30/30	25/25	25/25	15	15	15	40/40	15	15
	Maximum Overcurrent Protection Device Size	35/35	30/30	30/30	15	15	15	50/50	15	15
Compressor Motor	No.	1	1	1	1	1	1	1	1	1
	Volts	208/230	208/230	208/230	460	460	460	208/230	575	575
	Phase	3	3	3	3	3	3	1	3	3
	RPM	3450	3450	3450	3450	3450	3450	3450	3450	3450
	HP, Compressor 1	4	4	4	4	4	4	4	4	4
	Amps (RLA), Comp. 1	13.1/13.1	13.1/13.1	13.1/13.1	6.1	6.1	6.1	19.9/19.9	4.4	4.4
	Amps (LRA), Comp. 1	83.1/83.1	83.1/83.1	83.1/83.1	41	41	41	109/109	33	33
Condenser Motor	No.	1	1	1	1	1	1	1	1	1
	Volts	208/230	208/230	208/230	460	460	460	208/230	575	575
	Phase	1	1	1	1	1	1	1	1	1
	HP	1/3	1/3	1/3	1/3	1/3	1/3	1/3	1/3	1/3
	Amps (FLA, each)	1.5/1.5	1.5/1.5	1.5/1.5	1	1	1	1.5/1.5	0.8	0.8
	Amps (LRA, each)	3/3	3/3	3/3	1.9	1.9	1.9	3/3	1.9	1.9
Evaporator Fan	No.	1	1	1	1	1	1	1	1	1
	Volts	208/230	208/230	208/230	460	460	460	208/230	575	575
	Phase	1	3	3	1	3	3	1	3	3
	HP	1/2	1/2	3/4	1/2	1/2	3/4	1/2	3/4	3/4
	Amps (FLA, each)	4/4	2.8/2.8	3.4/3.4	2	1.4	1.6	4/4	1.3	1.3
	Amps (LRA, each)	6.7/6.7	11.3/11.3	16.8/16.8	3.6	6.2	8.4	6.7/6.7	6	6

1. Horsepower Per Compressor.

2. Amp Draw Per Motor. Multiply Value By Number of Motors to Determine Total Amps.

ELECTRICAL DATA – RKPN SERIES										
		A060CK	A060CL	A060CM	A060DK	A060DL	A060DM	A060JK	A060YL	A060YM
Unit Information	Unit Operating Voltage Range	187-253	187-253	187-253	414-506	414-506	414-506	187-253	517-633	517-633
	Volts	208/230	208/230	208/230	460	460	460	208/230	575	575
	Minimum Circuit Ampacity	30/30	26/26	27/27	15	13	13	43/43	10	10
	Minimum Overcurrent Protection Device Size	35/35	30/30	35/35	20	15	15	50/50	15	15
	Maximum Overcurrent Protection Device Size	45/45	40/40	40/40	20	20	20	60/60	15	15
Compressor Motor	No.	1	1	1	1	1	1	1	1	1
	Volts	208/230	208/230	208/230	460	460	460	208/230	575	575
	Phase	3	3	3	3	3	3	1	3	3
	RPM	3450	3450	3450	3450	3450	3450	3450	3450	3450
	HP, Compressor 1	5	5	5	5	5	5	5	5	5
	Amps (RLA), Comp. 1	16/16	16/16	16/16	7.8	7.8	7.8	26.4/26.4	5.7	5.7
	Amps (LRA), Comp. 1	110/110	110/110	110/110	52	52	52	134/134	39.9	39.9
Condenser Motor	No.	1	1	1	1	1	1	1	1	1
	Volts	208/230	208/230	208/230	460	460	460	208/230	575	575
	Phase	1	1	1	1	1	1	1	1	1
	HP	1/3	1/3	1/3	1/3	1/3	1/3	1/3	1/3	1/3
	Amps (FLA, each)	2.2/2.2	2.2/2.2	2.2/2.2	1	1	1	2.2/2.2	0.8	0.8
	Amps (LRA, each)	4.9/4.9	4.9/4.9	4.9/4.9	1.9	1.9	1.9	4.9/4.9	1.9	1.9
Evaporator Fan	No.	1	1	1	1	1	1	1	1	1
	Volts	208/230	208/230	208/230	460	460	460	208/230	575	575
	Phase	1	3	3	1	3	3	1	3	3
	HP	1	3/4	1	1	3/4	1	1	3/4	1
	Amps (FLA, each)	7.6/7.6	3.4/3.4	4.1/4.1	4	1.6	2	7.6/7.6	1.3	1.4
	Amps (LRA, each)	0/0	16.8/16.8	14.6/14.6	0	8.4	12	0/0	6	7.2

1. Horsepower Per Compressor.

2. Amp Draw Per Motor. Multiply Value By Number of Motors to Determine Total Amps.

ELECTRICAL DATA – RKQN SERIES

		A036CK	A036CL	A036CM	A036DK	A036DL	A036DM	A036JK	A048CK	A048CL
Unit Information	Unit Operating Voltage Range	187-253	187-253	187-253	414-506	414-506	414-506	187-253	187-253	187-253
	Volts	208/230	208/230	208/230	460	460	460	208/230	208/230	208/230
	Minimum Circuit Ampacity	17/17	16/16	16/16	11	10	10	24/24	24/24	21/21
	Minimum Overcurrent Protection Device Size	20/20	20/20	20/20	15	15	15	30/30	30/30	25/25
	Maximum Overcurrent Protection Device Size	25/25	20/20	25/25	15	15	15	35/35	35/35	30/30
Compressor Motor	No.	1	1	1	1	1	1	1	1	1
	Volts	208/230	208/230	208/230	460	460	460	208/230	208/230	208/230
	Phase	3	3	3	3	3	3	1	3	3
	RPM	3450	3450	3450	3450	3450	3450	3450	3450	3450
	HP, Compressor 1	3	3	3	3	3	3	3	4	4
	Amps (RLA), Comp. 1	9/9	9/9	9/9	5.6	5.6	5.6	14.1/14.1	13.1/13.1	13.1/13.1
	Amps (LRA), Comp. 1	71/71	71/71	71/71	38	38	38	77/77	83.1/83.1	83.1/83.1
Condenser Motor	No.	1	1	1	1	1	1	1	1	1
	Volts	208/230	208/230	208/230	460	460	460	208/230	208/230	208/230
	Phase	1	1	1	1	1	1	1	1	1
	HP	1/3	1/3	1/3	1/3	1/3	1/3	1/3	1/3	1/3
	Amps (FLA, each)	1.5/1.5	1.5/1.5	1.5/1.5	1	1	1	1.5/1.5	1.5/1.5	1.5/1.5
	Amps (LRA, each)	3/3	3/3	3/3	1.9	1.9	1.9	3/3	3/3	3/3
Evaporator Fan	No.	1	1	1	1	1	1	1	1	1
	Volts	208/230	208/230	208/230	460	460	460	208/230	208/230	208/230
	Phase	1	3	3	1	3	3	1	1	3
	HP	1/2	1/2	1/2	1/2	1/2	1/2	1/2	3/4	1/2
	Amps (FLA, each)	4.1/4.1	2.8/2.8	2.8/2.8	2.1	1.4	1.4	4.1/4.1	6/6	2.8/2.8
	Amps (LRA, each)	0/0	11.3/11.3	11.3/11.3	0	6.2	6.2	0/0	0/0	11.3/11.3

1. Horsepower Per Compressor.

2. Amp Draw Per Motor. Multiply Value By Number of Motors to Determine Total Amps.

ELECTRICAL DATA – RKQN SERIES											
		A048CM	A048DK	A048DL	A048DM	A048JK	A060CK	A060CV	A060DK	A060DV	A060JK
Unit Information	Unit Operating Voltage Range	187-253	414-506	414-506	414-506	187-253	187-253	187-253	414-506	414-506	187-253
	Volts	208/230	460	460	460	208/230	208/230	208/230	460	460	208/230
	Minimum Circuit Ampacity	22/22	12	11	11	33/33	31/31	32/32	15	16	46/46
	Minimum Overcurrent Protection Device Size	25/25	15	15	15	40/40	35/35	40/40	20	20	60/60
	Maximum Overcurrent Protection Device Size	30/30	15	15	15	50/50	45/45	45/45	20	20	60/60
Compressor Motor	No.	1	1	1	1	1	1	1	1	1	1
	Volts	208/230	460	460	460	208/230	208/230	208/230	460	460	208/230
	Phase	3	3	3	3	1	3	3	3	3	1
	RPM	3450	3450	3450	3450	3450	3450	3450	3450	3450	3450
	HP, Compressor 1	4	4	4	4	4	5	5	5	5	5
	Amps (RLA), Comp. 1	13.1/13.1	6.1	6.1	6.1	19.9/19.9	16.2/16.2	16.2/16.2	7.6	7.6	28.8/28.8
	Amps (LRA), Comp. 1	83.1/83.1	41	41	41	109/109	110/110	110/110	52	52	152.9/152.9
Condenser Motor	No.	1	1	1	1	1	1	1	1	1	1
	Volts	208/230	460	460	460	208/230	208/230	208/230	460	460	208/230
	Phase	1	1	1	1	1	1	1	1	1	1
	HP	1/3	1/3	1/3	1/3	1/3	1/3	1/3	1/3	1/3	1/3
	Amps (FLA, each)	1.5/1.5	1	1	1	1.5/1.5	2.2/2.2	2.2/2.2	1	1	2.2/2.2
	Amps (LRA, each)	3/3	1.9	1.9	1.9	3/3	4.9/4.9	4.9/4.9	1.9	1.9	4.9/4.9
Evaporator Fan	No.	1	1	1	1	1	1	1	1	1	1
	Volts	208/230	460	460	460	208/230	208/230	208/230	460	460	208/230
	Phase	3	1	3	3	1	1	3	1	3	1
	HP	3/4	3/4	1/2	3/4	3/4	1	1	1	1	1
	Amps (FLA, each)	3.4/3.4	3.2	1.4	1.6	6/6	7.6/7.6	9.1/9.1	4	4.6	7.6/7.6
	Amps (LRA, each)	16.8/16.8	0	6.2	8.4	0/0	0/0	0/0	0	0	0/0

1. Horsepower Per Compressor.

2. Amp Draw Per Motor. Multiply Value By Number of Motors to Determine Total Amps.

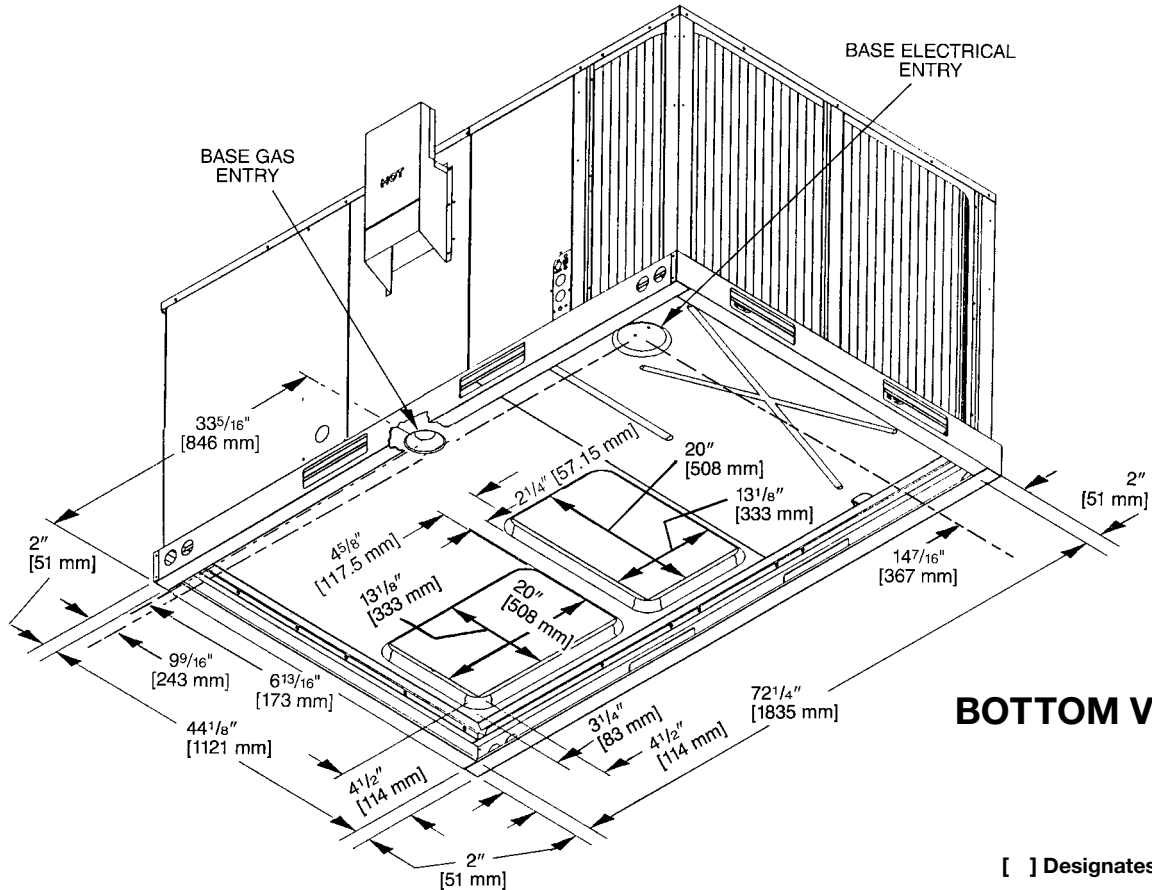
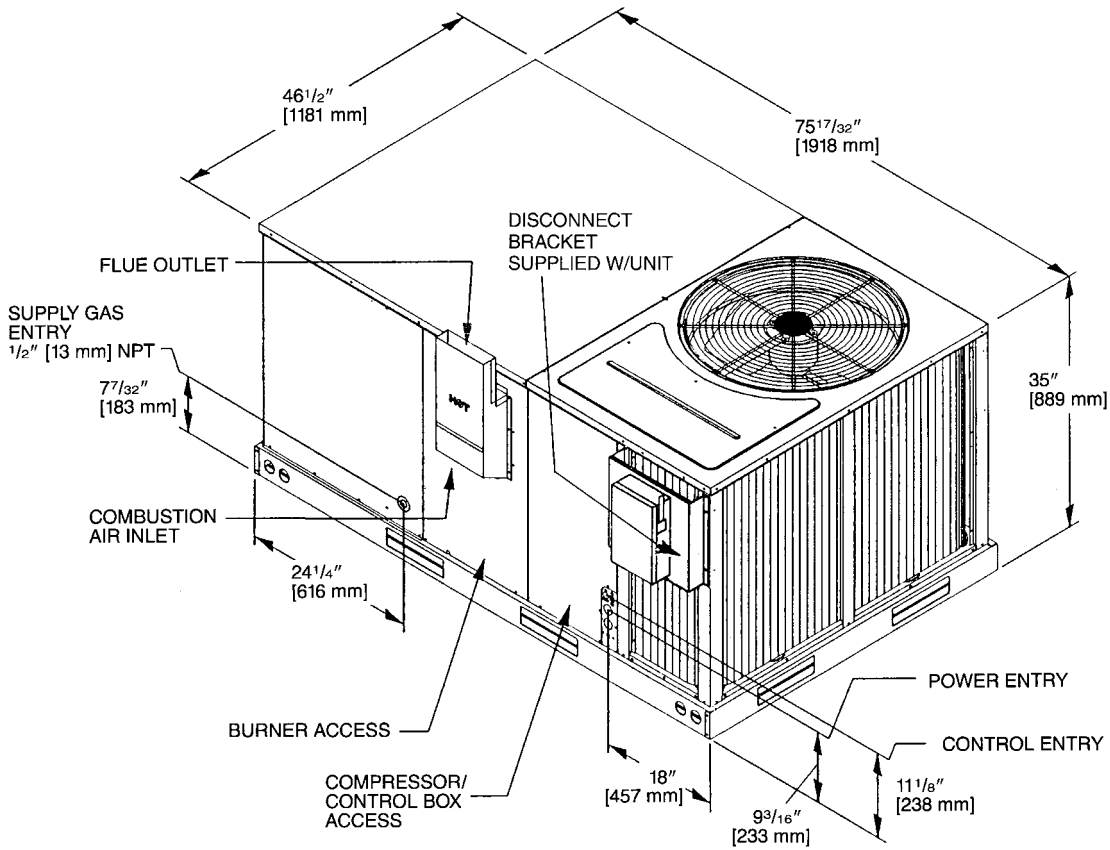

[] Designates Metric Conversions

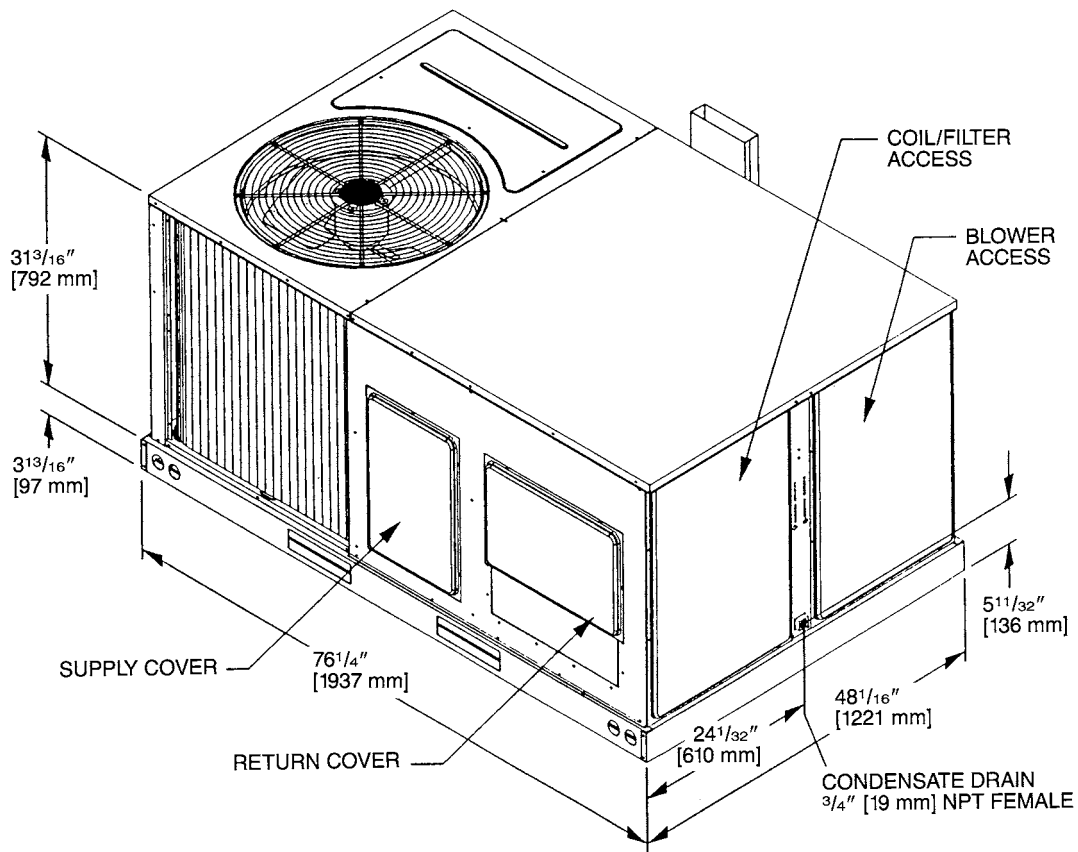

SUPPLY AND RETURN DIMENSIONS

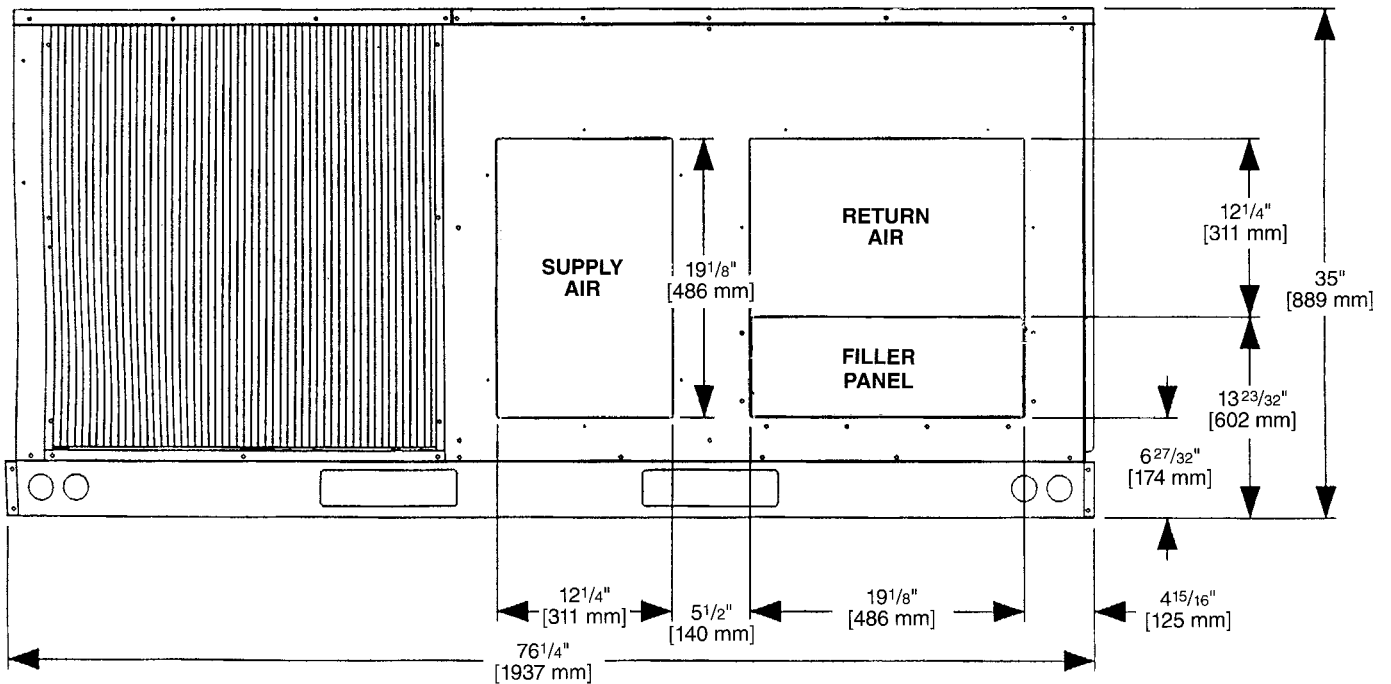

[] Designates Metric Conversions





WEIGHTS

Accessory	3-5 Ton [10.6-17.6 kW]	
	Shipping	Operating
	lbs [kg]	lbs [kg]
Economizer with Single Enthalpy	70 [32]	60 [27]
Power Exhaust	70 [32]	67 [30]
Fresh Air Damper (Manual)	11 [5]	9 [4]
Fresh Air Damper (Motorized)	13 [6]	11 [5]
Roof Curb 14"	92 [42]	88 [40]
Roof Curb 24"	108 [49]	104 [47]
Concentric Diffuser 18" Flush	37 [17]	26 [12]
Concentric Diffuser 20" Flush	54 [24]	42 [19]
Side Discharge Concentric Diffuser RXRN-FA60	35 [16]	20 [9]
Side Discharge Concentric Diffuser RXRN-FA65	55 [25]	40 [18]

CENTER OF GRAVITY (C.G.)

Capacity Tons [kW]	A in. [mm]	B in. [mm]
3-5 [10.6-17.6]	38 ¹ / ₄ [972]	25 ³ / ₄ [654]

Capacity Tons [kW]	Corner Weights by Percentage			
	A	B	C	D
3-5 [10.6-17.6]	22%	27%	23%	28%

CLEARANCES

(3 to 5 Ton [10.6 to 17.6 kW] Models)

The following minimum clearances are recommended for proper unit performance and serviceability.

Recommended Clearance in. [mm]	Location
48 [1219]	A - Front
18 [457]	B - Condenser Coil
12 [305]	C - Duct Side
36 [914]	D - Evaporator End
60 [1524]	E - Above

*Without Economizer, 57" [1448 mm] With Economizer

NOTE: Supply duct may be installed with "0" inch clearance to combustible materials, provided 1" [25.4 mm] minimum Fiberglass insulation is applied either inside or on the outside of the duct.

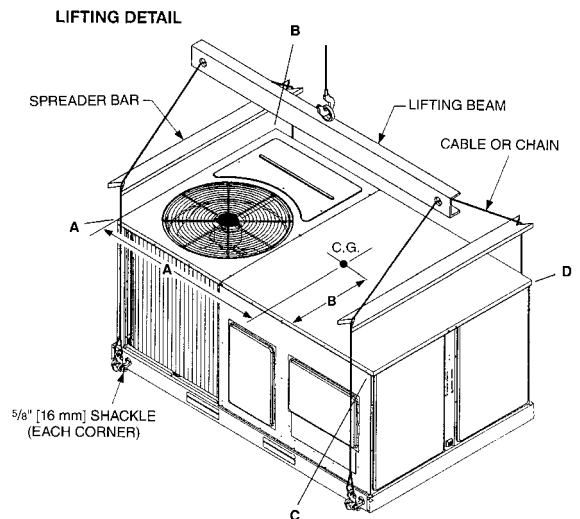
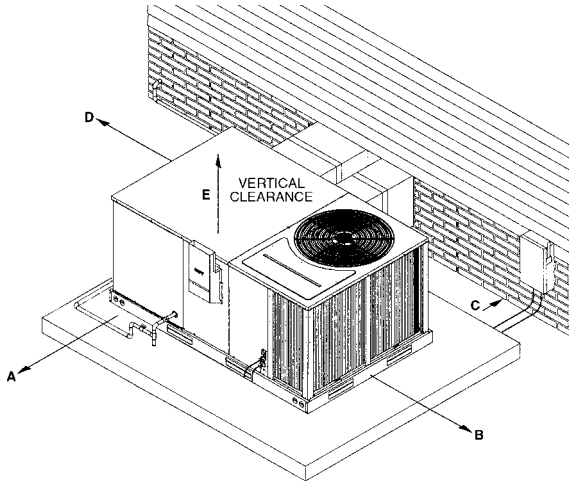

[] Designates Metric Conversions



ACCESSORY EQUIPMENT

Accessory Description	Model Application 3 to 5 Ton [10.6 to 17.6 kW]	Accessory Model No. 3 to 5 Ton [10.6 to 17.6 kW]	Factory Installed 3 to 5 Ton [10.6 to 17.6 kW]
Thermostats	RKNN/RKPN/RKQN	See Thermostat Specification Sheet (T11-001)	No
Roofcurb, 14"	RKNN/RKPN/RKQN	RXKG-CAD14	No
Roofcurb, 24"	RKNN/RKPN/RKQN	RXKG-CAD24	No
Roofcurb Adapters	RKNN/RKPN/RKQN	RXXR-BBCDB21 RXXR-BBCDB22 RXXR-BBCDB23	No
Economizer with Single Enthalpy ②	RKNN/RKPN/RKQN	AXRD-01RECAM3	Yes
Economizer with Smoke Detector ②	RKNN/RKPN/RKQN	AXRD-01RECBM3	Yes
Dual Enthalpy Kit	RKNN/RKPN/RKQN	RXXR-AV02	No
CO ² Sensor Only	RKNN/RKPN/RKQN	RXXR-AR02	No
Power Exhaust	RKNN/RKPN/RKQN	AXRX-BGF04C, D, Y	No
Fresh Air Damper Manual	RKNN/RKPN/RKQN	AXRF-FBA1	No
Fresh Air Damper Motorized	RKNN/RKPN/RKQN	AXRF-JJB1	No
Rectangular to Round 18" Duct Adapters for Concentric Diffuser	RKNN/RKPN/RKQN	RXMC-CB03	No
Rectangular to Round 20" Duct Adapters for Concentric Diffuser	RKNN/RKPN/RKQN	RXMC-CB04	No
Concentric Diffuser 18" Step	RKNN/RKPN/RKQN	RXRN-FA60, RXRN-FA65	No
Concentric Diffuser 18" Flush	RKNN/RKPN/RKQN	RXRN-FA70, RXRN-FA75	No
Rectangular to Round 16" Side	RKNN/RKPN/RKQN	RXMC-BB01	No
Louver Kit (2 Sides) 3-Ton	RKNN/RKPN/RKQN	AXRX-AAD02B	Yes
Louver Kit (3 Sides) 4 & 5-Ton	RKNN/RKPN/RKQN	AXRX-AAD01B	Yes
Time Delay	RKNN/RKPN/RKQN	RXMD-B01	Yes
Low Ambient Control to 0°F [-18°C]	RKNN/RKPN/RKQN	RXRZ-A04	Yes
LP Conversion Kits for use with White Rodgers Gas Valve ①	RKNN/RKPN/RKQN	RXGJ-EP84W	No
LP Conversion Kits for use with Honeywell Gas Valve ①	RKNN/RKPN/RKQN	RXGJ-EP85H	No
Canadian High Altitude Kit (for Natural Gas Only) ①	RKNN/RKPN/RKQN	RXXR-AH01	No
Freeze Stat	RKNN/RKPN/RLQN	RXXR-AM05	Yes

*Voltage J = 208/230 VAC-1PH-60HZ D = 460 VAC-3PH-60HZ
 C = 208/230 VAC-3PH-60HZ

NOTES: ① If a particular unit is to be converted to operate on **LP (propane)** for elevations above 2000 ft. in Canada, the existing Natural Gas to LP Conversion Kits for the subject models already contain the necessary orifices and instructions to de-rate the input for 2000-4500 ft. Canadian applications.

② Economizer is designed for downflow or horizontal applications.

[] Designates Metric Conversions



THERMOSTATS



200-Series *
Programmable



300-Series *
Deluxe
Programmable



400-Series *
Special Applications/
Programmable

500-Series *
Communicating/
Programmable

Brand	Descriptor (3 Characters)	Series (3 Characters)	System (2 Characters)	Type (2 Characters)
RHC	- TST	213	UN	MS
RHC=Rheem	TST=Thermostat	200=Programmable 300=Deluxe Programmable 400=Special Applications/ Programmable 500=Communicating/ Programmable	GE=Gas/Electric UN=Universal (AC/HP/GE) MD=Modulating Furnace DF=Dual Fuel CM=Communicating	SS=Single-Stage MS=Multi-Stage

* Photos are representative. Actual models may vary.

For detailed thermostat match-up information,
see specification sheet form number T11-001.

Roofcurb Adapters

Old Models

OLD CURB MODEL ROOFCURB ADAPTER

NEW MODEL

MEDIUM CABINET (3 TON [11 kW])

(-)SNC, (-)SND, (-)SNE
(-)RGE, (-)RGF, (-)RGG
(-)PNC, (-)PND

21 SERIES

RXPA-CA21 (1)
RXRA-DB21 (2)

RXRX-BBCDB21

LARGE CABINET

(3-3 1/2 TON [11-12 kW])

(-)RGE, (-)RGF, (-)RGG,
(-)RGH (3 TON [11 kW])

22 SERIES

RXPA-CA22 (1)
RXRA-DB22 (2)

RXRX-BBCDB22

EXTRA LARGE CABINET

(3 1/2-5 TON [12-18 kW])

(-)SNC, (-)SND, (-)SNE
(-)RGE, (-)RGF,
(-)RGG (4-5 TON [14-18 kW])
(-)PNC, (-)PND, (-)RGH
(3 1/2, 4 TON [12-14 kW])

23 SERIES

RXPA-CA23 (1)
RXRA-DB23 (2)

RXRX-BBCDB23

RKNN-
RKPN-
RKQN-

(1) SLOPE TYPE (2) FULL PERIMETER TYPE

[] Designates Metric Conversions



Roofcurb Adapters

Carrier to Rheem Roofcurb Adapter - RXRX-EACC35*

Replaces Carrier/Bryant/ICP Models:

Carrier Models		
Packaged G/E	Packaged AC	Packaged HP
48DJ*004 - 007	50DJ004 - 007	50QJ004-006
48GJ*006	50GJ006	
48HE*003 - 006	50HE003 - 006	50HEQ003 - 006
48HJ*004 - 007	50HJ004 - 007	50HJQ004 - 007
48HM*007	50HM007	
48LJ*004 - 007	50LJ004 - 007	50LJQ004 - 006
48TC*004 - 007	50TC004 - 007	50TCQ004 - 007
48TF-004 - 007	50TF004 - 007	50TFQ004 - 007
48TJ*004 - 007	50TJ004 - 007	50TJQ004 - 007
48TM*004 - 007	50TM004 - 007	

Bryant Models		
Packaged G/E	Packaged AC	Packaged HP
581A*V036 - 072	551A*X036 - 072	549B*X036 - 072
581B*V036 - 072	551B*X036 - 072	
580C*V036 - 072	558C*X036 - 072	548C*X036 - 060
580D*V036 - 072	558D*X036 - 072	548D*X036 - 072
580F*V036 - 072	558F*X036 - 072	548F*X036 - 072
580J*04 - 07	558J*04 - 07	548J*04 - 07

ICP Models		
Packaged G/E	Packaged AC	Packaged HP
PGE036 - 072	PAE036 - 072	PHE072
PGH036 - 072	PAH036 - 072	PHH036 - 072
PGS072	PAS072	PHS072
RGS036 - 072	RAS036 - 072	RHS036 - 072

*RXRX-EACC35 Carrier to Rheem roofcurb adapter requires high static "M" drive for all tonnages.

Trane to Rheem Roofcurb Adapter - RXRX-EACT35

Replaces Trane Models:

Trane Models		
Packaged G/E	Packaged AC	Packaged HP
YCD-036,037,048,049,060	TCD-036,037,048,049,060	WCD-036,037,048,049,060

Model #	CFM	Static Pressure
RXRX-EACT35	1000	.08
	1200	.10
	1400	.15
	1600	.18
	1800	.21
	2000	.25
	2200	.30

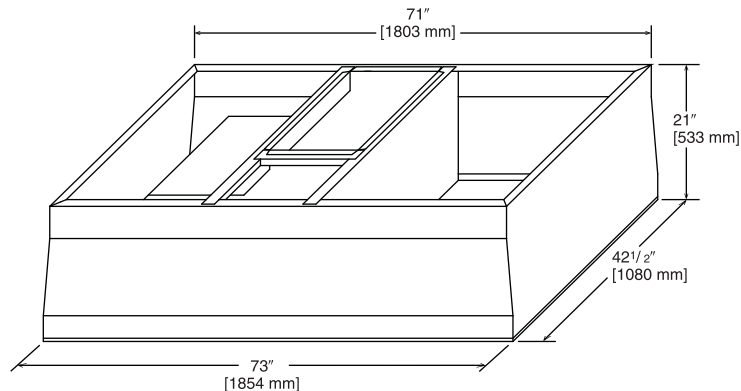

Model #	CFM	Static Pressure
RXRX-EACC35	1000	.20
	1200	.25
	1400	.30
	1600	.35
	1800	.40
	2000	.45
	2200	.50

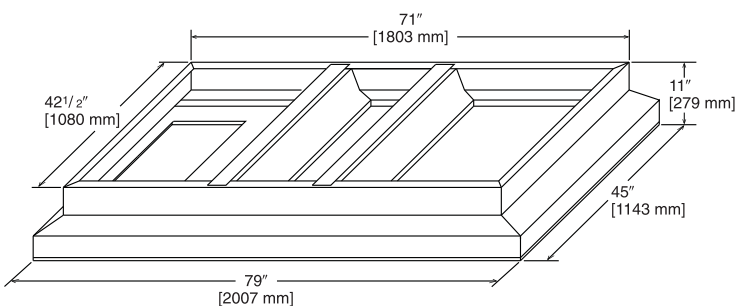

[] Designates Metric Conversions

ROOFCURBS (Full Perimeter)

- Rheem's new roofcurb design can be utilized on 3 through 5 ton [10.6-17.6 kW] models.
- Two available heights (14" [356 mm] and 24" [610 mm]) for ALL models.
- Quick assembly corners for simple and fast assembly
- Opening provided in bottom pan to match the "Thru the Curb" electrical connection opening provided on the unit base pan.
- 2" [51 mm] x 4" [102 mm] Nailer provided.
- Insulating panels provided.
- Sealing gasket (28" [711 mm]) provided with Roofcurb.
- Packaged for easy field assembly.

Roofcurb Model	Height of Curb
RXKG-CAD14	14" [356 mm]
RXKG-CAD24	24" [610 mm]

[] Designates Metric Conversions

TYPICAL INSTALLATION

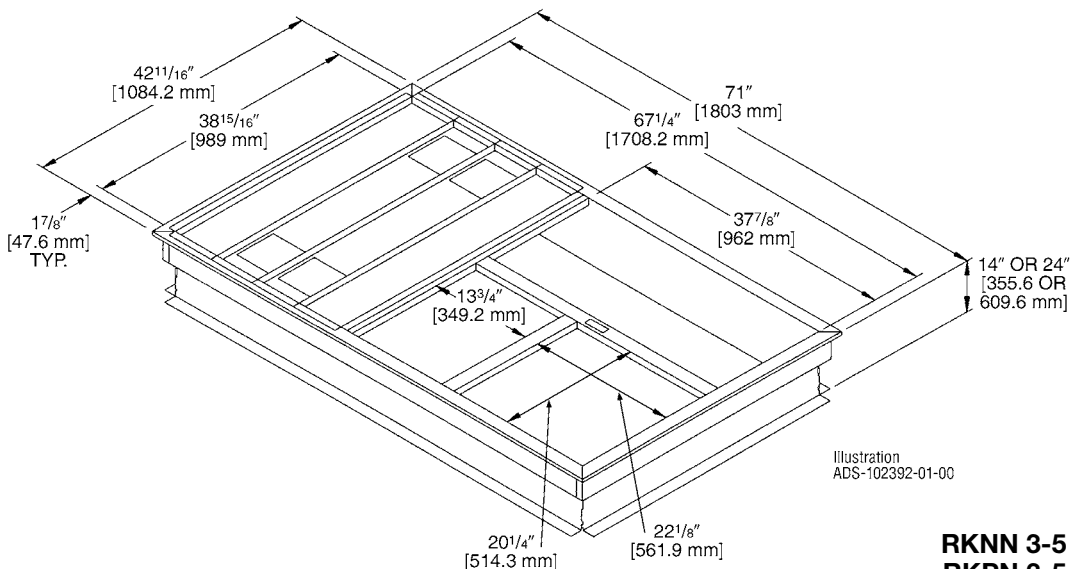
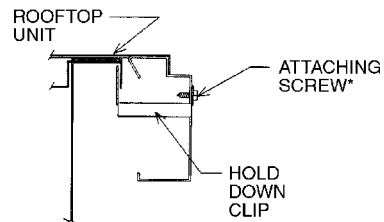
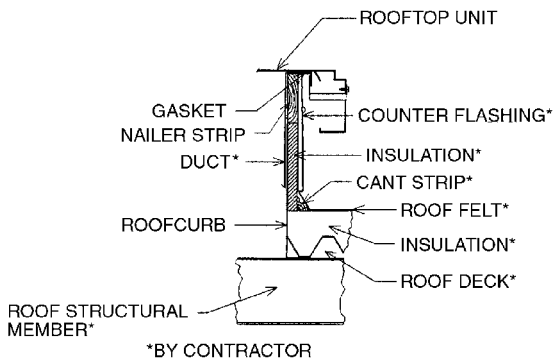
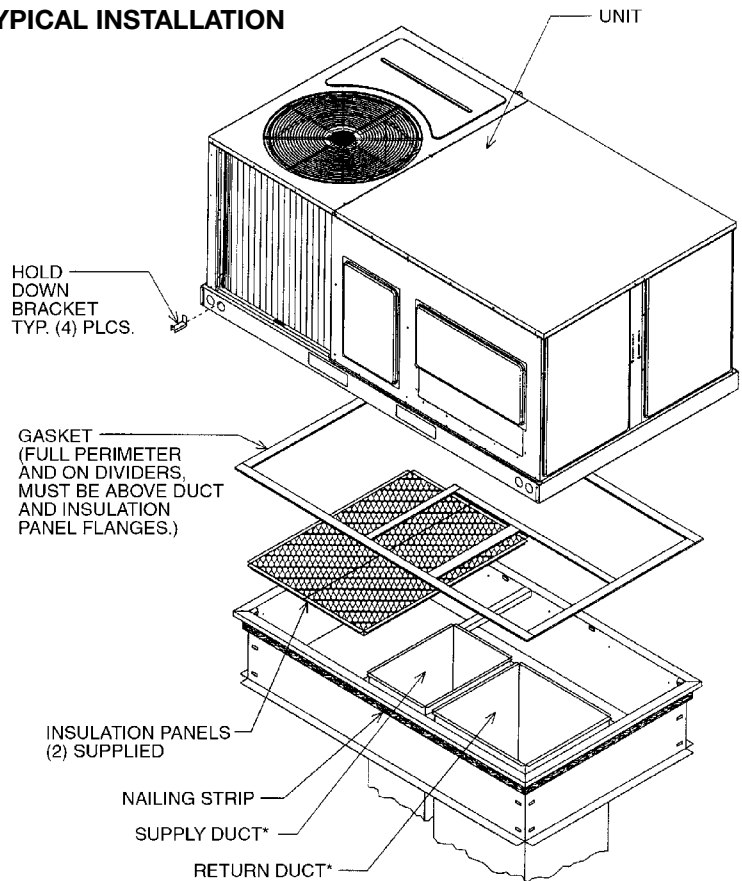

Illustration
ADS-102392-01-00

**ROOFCURB FOR
RKNN 3-5 TON [10.6-17.6 kW] MODELS
RKPN 3-5 TON [10.6-17.6 kW] MODELS
RKQN 3-5 TON [10.6-17.6 kW] MODELS**

ECONOMIZERS

AXRD-01RECAM3—3-5 Ton [10.6-17.6 kW] Models
AXRD-01RECBM3—3-5 Ton [10.6-17.6 kW] Models

RXXR-AV02—3-5 Ton [10.6-17.6 kW] Models

RXXR-AR02—3-5 Ton [10.6-17.6 kW] Models

Single Enthalpy (with Barometric Relief)
Single Enthalpy and Smoke Detector

Dual Enthalpy Kit

Optional CO₂ Sensor

- Features **Honeywell JADE™** Digital Controls
- Available factory installed or field accessory
- Gear Driven Direct Drive Actuator
- Fully Modulating (0-100%)
- Low Leakage Dampers
- Horizontal or Downflow Applications
- Slip-In Design for Easy Installations
- Plug-In Polarized 12-pin Electrical Connections
- Pre-configuring—No Field Adjustments Necessary
- Standard Barometric Relief Damper Provided
- Single Enthalpy with Dual Enthalpy upgrade kit
- CO₂ Input Sensor Available (field installed)
- Economizer slips in complete for downflow or horizontal duct applications
- Field assembled hood ships with Economizer
- Field installed power exhaust available.

[] Designates Metric Conversions

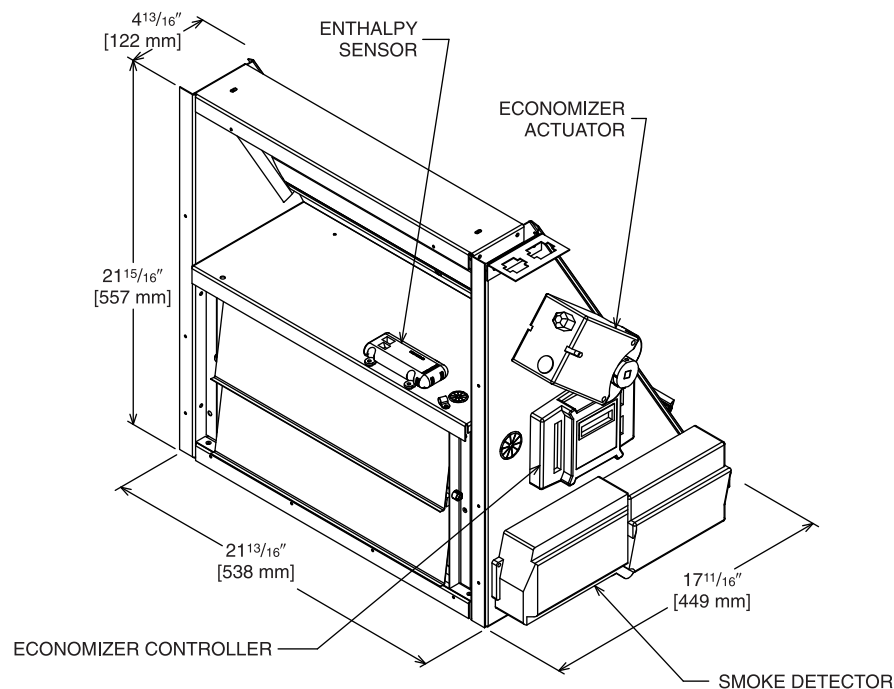
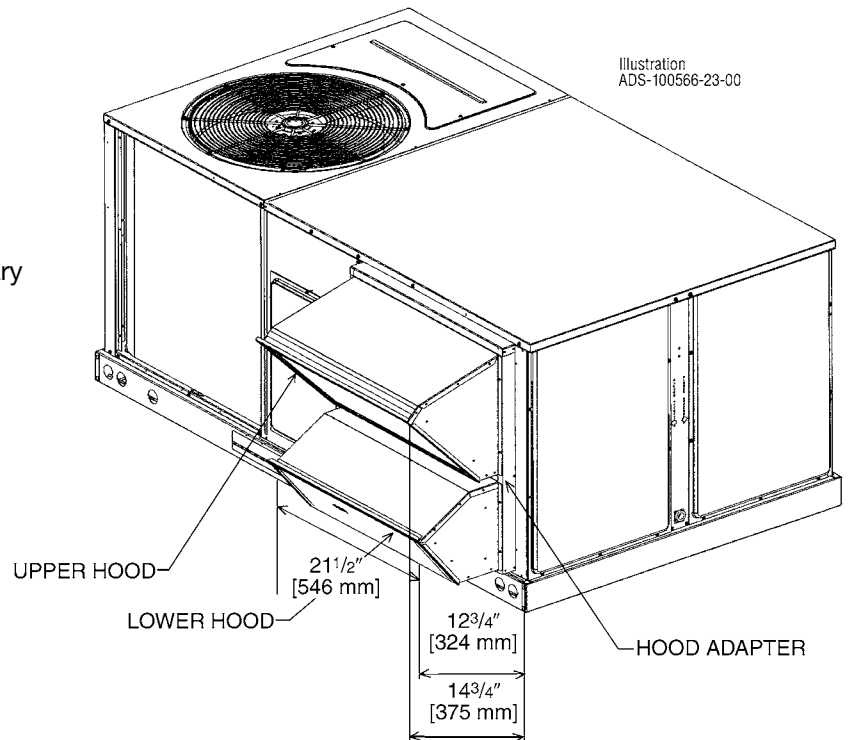



INTEGRAL POWER EXHAUST FOR ECONOMIZER (FIELD INSTALLED ONLY)

AXRX-BGF04C—RKNN-/RKPN- 3-5 Ton [10.6-17.6 kW] Models
208/230 V, 1PH and 3PH, 60 Hz

AXRX-BGF04D—RKNN 3-5 Ton [10.6-17.6 kW] Models & RKPN 3-5 Ton [10.6-17.6 kW] Models
460 V, 3PH, 60 Hz

AXRX-BGF04Y—RKNN 3-5 Ton [10.6-17.6 kW] Models & RKPN 3-5 Ton [10.6-17.6 kW] Models
575V, 3PH, 60 Hz

- For **Honeywell** economizer.
- Downflow or horizontal applications.
- Requires separate 208-230 volt – 1 PH power supply with disconnect or requires separate 460V - 1 PH power supply with disconnect.
- Adjustable switch on economizer, factory preset to energize power exhaust at 95% outside air position.
- Polarized plug connects power exhaust relay to economizer.

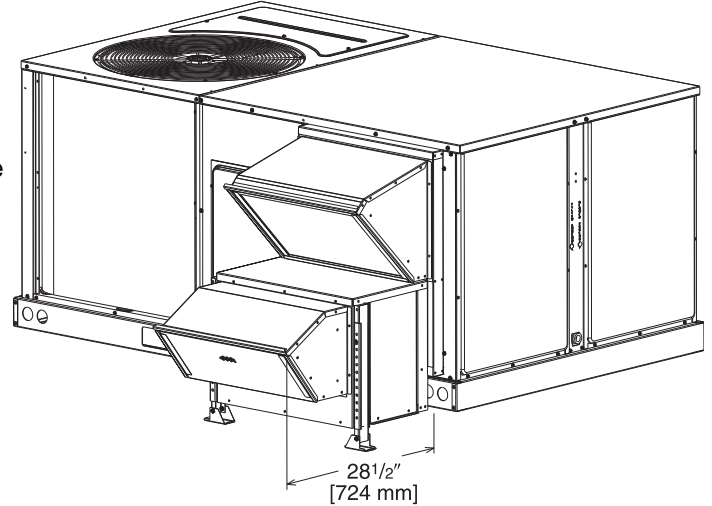

POWER EXHAUST KIT FOR AXRD-01REC(-) ECONOMIZERS

Model No.	No. of Fans	Volts	Phase	Watts (ea.)	High Speed		FLA (ea.)	LRA (ea.)
					CFM ①	RPM		
AXRX-BGF04C	1	208-230	1	1000	2500	1725	4.4	23.7
AXRX-BGF04D	1	460	1	800	2370	1620	1.8	4.1
AXRX-BGF04Y	1	575	1	800	2370	1620	1.5	3.3

① CFM is at 0" W.C. external static pressure.

FRESH AIR DAMPER

RKNN 3-5 Ton [10.6-17.6 kW] Models
RKPN 3-5 Ton [10.6-17.6 kW] Models
RKQN 3-5 Ton [10.6-17.6 kW] Models
AXRF-FBA1 (Manual)
AXRF-JJB1 (Motorized)

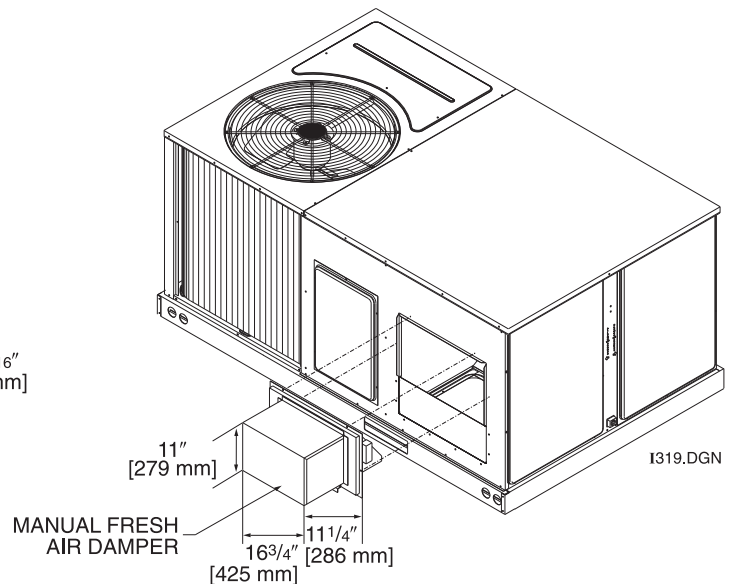
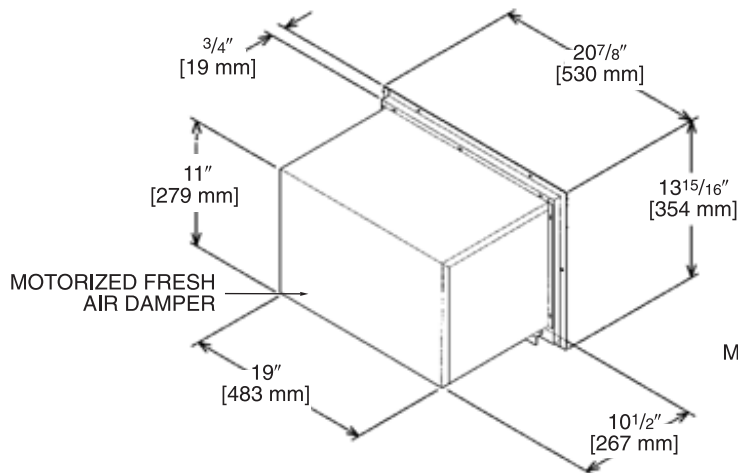

[] Designates Metric Conversions



DUCT ADAPTERS (RKNN 3-5 Ton [10.6-17.6 kW] Models) (RKPN 3-5 Ton [10.6-17.6 kW] Models) (RKQN 3-5 Ton [10.6-17.6 kW] Models) Rectangular to Round Transitions (Downflow)

RXMC-CB03 sizes available
 18" [457 mm] fit all units.
 Drops into and secures to
 RXKG- Series Roofcurbs.

**For use with
 Concentric Diffusers.**

[] Designates Metric Conversions

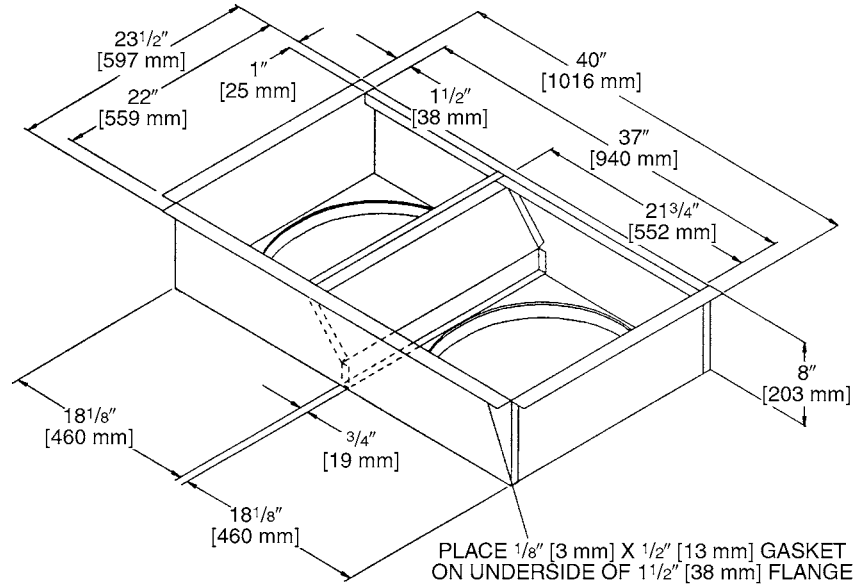



SIDE DISCHARGE CONCENTRIC DIFFUSER

RXRN-FA60 (3 to 6 Ton [10.6 to 21.1 kW] Models)

RXRN-FA65 (3 to 7.5 Ton [10.6 to 26.4 kW] Models)

For Use With Duct Adapter (RXMC)

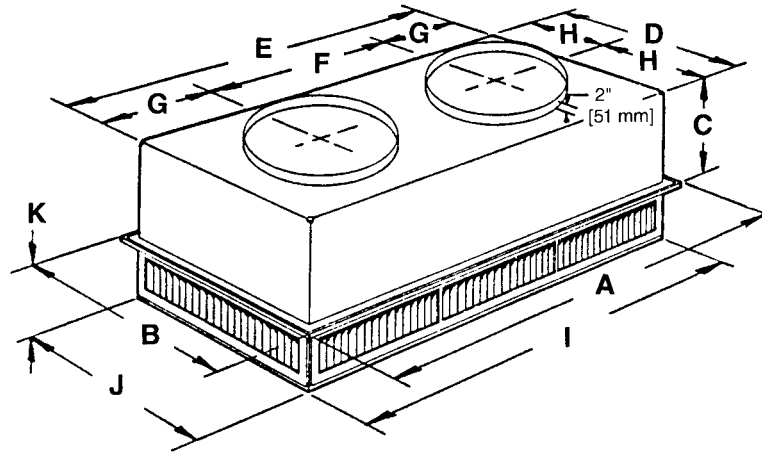

DIMENSIONAL DATA

Model No.	A	B	C	D	E	F	G	H	I	J	K	Duct Size
RXRN-FA60	47 ⁵ / ₈ " [1210 mm]	23 ⁵ / ₈ " [600 mm]	11 ³ / ₈ " [289 mm]	21 ¹ / ₂ " [546 mm]	45 ¹ / ₂ " [1156 mm]	22 ¹ / ₂ " [572 mm]	11 ¹ / ₂ " [292 mm]	10 ³ / ₄ " [273 mm]	45 ¹ / ₂ " [1156 mm]	21 ¹ / ₂ " [546 mm]	7 ¹ / ₈ " [181 mm]	18RD
RXRN-FA65	47 ⁵ / ₈ " [1210 mm]	29 ⁵ / ₈ " [752 mm]	14 ³ / ₈ " [365 mm]	27 ¹ / ₂ " [699 mm]	45 ¹ / ₂ " [1156 mm]	22 ¹ / ₂ " [572 mm]	11 ¹ / ₂ " [292 mm]	13 ³ / ₄ " [349 mm]	45 ¹ / ₂ " [1156 mm]	27 ¹ / ₂ " [699 mm]	8 ¹ / ₈ " [206 mm]	20RD

ENGINEERING DATA

Model No.	CFM [L/s]	Static Pressure	Throw Feet	Neck Vel.	Jet Vel.	Noise Level
RXRN-FA60	1000 [472]	.14	10-17	351	351	20
	1200 [566]	.17	11-18	421	421	20
	1400 [661]	.20	12-19	491	491	20
	1600 [755]	.24	12-20	561	561	20
	1800 [850]	.30	13-21	632	632	20
	2000 [944]	.36	14-23	702	702	20
	2200 [1038]	.40	16-25	772	772	20
RXRN-FA65	2600 [1227]	.17	24-29	669	669	20
	2800 [1321]	.20	25-30	720	720	25
	3000 [1416]	.25	27-33	772	772	25
	3200 [1510]	.31	28-35	623	623	25
	3400 [1605]	.37	30-37	874	874	30

[] Designates Metric Conversions



FLUSH MOUNT CONCENTRIC DIFFUSER

RXRN-FA70 (3 to 6 Ton [10.6 to 21.1 kW] Models)
 RXRN-FA75 (3 to 7.5 Ton [10.6 to 26.4 kW] Models)

For Use With Duct Adapter (RXMC)

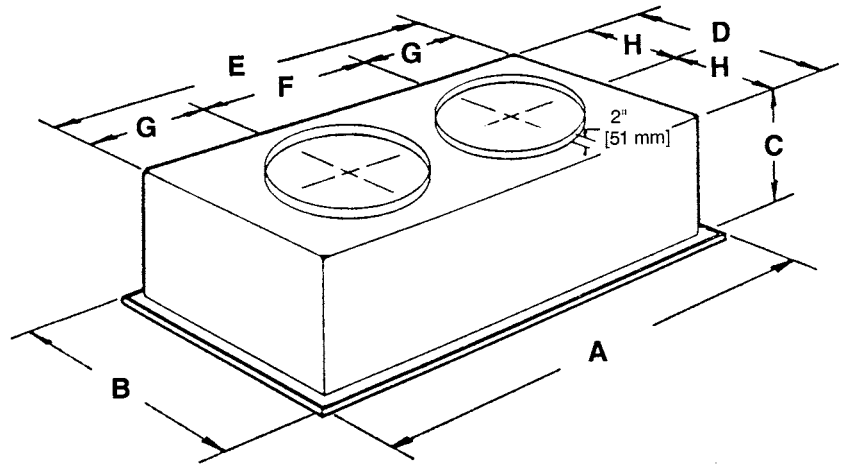

DIMENSIONAL DATA

Model No.	A	B	C	D	E	F	G	H	Duct Size
RXRN-FA70	47 ⁵ / ₈ " [1210 mm]	23 ⁵ / ₈ " [600 mm]	13 ¹ / ₂ " [343 mm]	21" [533 mm]	45" [1143 mm]	22 ¹ / ₂ " [572 mm]	11 ¹ / ₄ " [286 mm]	10 ¹ / ₂ " [267 mm]	18RD
RXRN-FA75	47 ⁵ / ₈ " [1210 mm]	29 ⁵ / ₈ " [752 mm]	16 ⁵ / ₈ " [442 mm]	27" [666 mm]	45" [1143 mm]	22 ¹ / ₂ " [572 mm]	11 ¹ / ₄ " [286 mm]	13 ¹ / ₂ " [343 mm]	20RD

ENGINEERING DATA

Model No.	CFM [L/s]	Static Pressure	Throw Feet	Neck Vel.	Jet Vel.	Noise Level
RXRN-FA70	1000 [472]	.14	15-20	391	694	20
	1200 [566]	.17	16-22	469	833	25
	1400 [661]	.20	17-24	547	972	30
	1600 [755]	.24	18-25	625	1111	30
	1800 [850]	.30	20-28	703	1250	35
	2000 [944]	.36	21-29	781	1389	40
	2200 [1038]	.40	22-30	859	1528	40
RXRN-FA75	2600 [1227]	.17	19-24	663	1294	30
	2800 [1321]	.20	20-28	714	1393	35
	3000 [1416]	.25	21-29	765	1492	35
	3200 [1510]	.31	22-29	616	1592	40
	3400 [1605]	.37	22-30	667	1692	40

[] Designates Metric Conversions

GUIDE SPECIFICATIONS RKNN/RKPN/RKQN-A036 thru A060

You may copy this document directly into your building specification. This specification is written to comply with the 2004 version of the “master-format” as published by the Construction Specification Institute. www.csinet.org.

GAS HEAT PACKAGED ROOFTOP

HVAC Guide Specifications

Size Range: 3 to 5 Nominal Tons

Section	Description
---------	-------------

23 06 80	Schedules for Decentralized HVAC Equipment
-----------------	---

23 06 80.13	Decentralized Unitary HVAC Equipment Schedule
--------------------	--

23 06 80.13.A.	Rooftop unit schedule
----------------	-----------------------

1. Schedule is per the project specification requirements.

23 07 16	HVAC Equipment Insulation
-----------------	----------------------------------

23 07 16.13	Decentralized, Rooftop Units:
--------------------	--------------------------------------

1. Interior cabinet surfaces shall be insulated with a minimum 3/4-in. thick, minimum 1-1/2 lb density, flexible fiberglass insulation bonded with a phenolic binder, with aluminum foil facing on the air side.
2. Insulation and adhesive shall meet NFPA 90A requirements for flame spread and smoke generation.

23 09 13	Instrumentation and Control Devices for HVAC
-----------------	---

23 09 13.23	Sensors and Transmitters:
--------------------	----------------------------------

23 09 13.23.A.	Thermostats
----------------	-------------

1. Thermostat must
 - a. have capability to energize 2 different stages of cooling, and 1 stage of heating.
 - b. must include capability for occupancy scheduling.

23 09 33	Electric and Electronic Control System for HVAC
-----------------	--

23 09 33.13	Decentralized, Rooftop Units:
--------------------	--------------------------------------

23 09 33.13.A.	General:
----------------	----------

1. Shall be complete with self-contained low-voltage control circuit. Transformer size is 40VA.
2. Shall utilize color-coded wiring.
3. Unit shall provide “pigtail” termination points for connection of control wiring.
4. The heat exchanger shall be controlled by an integrated furnace controller (IFC) microprocessor. See heat exchanger section of this specification.

23 09 33.13.B.	Safeties:
----------------	-----------

1. Compressor over-temperature, over current.
2. Loss of charge switch.
3. High-pressure switch.
4. Automatic reset, motor thermal overload protector.
5. Heating section shall be provided with the following minimum protections.
 - a. High-temperature limit switches.
 - b. Induced draft motor pressure switch.
 - c. Flame rollout switch.
 - d. Flame proving controls.

23 09 93	Sequence of Operations for HVAC Controls
-----------------	---

23 09 93.13	Decentralized, Rooftop Units:
--------------------	--------------------------------------

23 09 93.13	INSERT SEQUENCE OF OPERATION
-------------	------------------------------

23 40 13	Panel Air Filters
-----------------	--------------------------

23 40 13.13	Decentralized, Rooftop Units:
--------------------	--------------------------------------

23 40 13.13.A.	Standard filter section
----------------	-------------------------

1. Shall consist of factory-installed, low velocity, throwaway 1-in. thick fiberglass filters of commercially available sizes.
2. Unit shall use only one filter size. Multiple sizes are not acceptable.
3. Filter face velocity shall not exceed 365 fpm at nominal airflows.
4. Filters shall be accessible through an access panel as described in the unit cabinet section of the specification (23 81 19.13.H).
5. Filter rack will also accept 2-in thick fiberglass filters of commercially available sizes by removal of a tab.

23 81 19	Self-Contained Air Conditioners
-----------------	--

23 81 19.13	Small-Capacity Self-Contained Air Conditioners
--------------------	---

23 81 19.13.A.	General
----------------	---------

1. Outdoor, rooftop mounted, electrically controlled, heating and cooling unit utilizing a hermetic scroll compressor for cooling duty and gas combustion for heating duty.
2. Factory assembled, single-piece heating and cooling rooftop unit. Contained within the unit enclosure shall be all factory wiring, piping, controls, and special features required prior to field start-up.
3. Unit shall use environmentally safe, R-410A refrigerant.
4. Unit shall be installed in accordance with the manufacturer’s instructions.
5. Unit must be selected and installed in compliance with local, state, and federal codes.

23 81 19.13.B. Quality Assurance

1. Unit meets ASHRAE 90.1-2010 minimum efficiency requirements.
2. Unit shall be rated in accordance with AHRI Standards 210/240.
3. Unit shall be designed to conform to ASHRAE 15-2010.
4. Unit shall be UL-tested and certified in accordance with ANSI Z21.47 Standards and UL-listed and certified under Canadian standards as a total package for safety requirements.
5. Insulation and adhesive shall meet NFPA 90A requirements for flame spread and smoke generation.
6. Unit casing shall be capable of withstanding 500-hour salt spray exposure per ASTM B117 (scribed specimen).
7. Unit casing shall be capable of withstanding Federal Test Method Standard No. 141 (Method 6061) 5000-hour salt spray.
8. Unit shall be designed in accordance with ISO 9001:2008, and shall be manufactured in a facility registered by ISO 9001:2008.
9. Roof curb shall be designed to conform to NRCA Standards.
10. Unit shall be subjected to a completely automated run test on the assembly line. The data for each unit will be stored at the factory, and must be available upon request.
11. Unit shall be designed in accordance with UL Standard 1995, including tested to withstand rain.
12. Unit shall be constructed to prevent intrusion of snow and tested to prevent snow intrusion into the control box up to 40 mph.

23 81 19.13.C. Delivery, Storage, and Handling

1. Unit shall be stored and handled per manufacturer's recommendations.
2. Lifted by crane requires either shipping top panel or spreader bars.
3. Unit shall only be stored or positioned in the upright position.

23 81 19.13.E. Project Conditions

1. As specified in the contract.

23 81 19.13.F. Operating Characteristics

1. Unit shall be capable of starting and running at 115°F (46°C) ambient outdoor temperature, meeting maximum load criteria of AHRI Standard 210/240 at ± 10% voltage.
2. Compressor with standard controls shall be capable of operation down to 40°F (4°C), ambient outdoor temperatures. Accessory low ambient kit is necessary if mechanically cooling at ambient temperatures below 40°F (4°C).
3. Unit shall discharge supply air vertically or horizontally as shown on contract drawings.
4. Unit shall be factory configured for vertical supply & return configurations.
5. Unit shall be field convertible from vertical to horizontal configuration.

23 81 19.13.G. Electrical Requirements

1. Main power supply voltage, phase, and frequency must match those required by the manufacturer.

23 81 19.13.H. Unit Cabinet

1. Unit cabinet shall be constructed of galvanized steel, and shall be bonderized and coated with a baked enamel finish on all externally exposed surfaces.
2. Unit cabinet exterior paint shall be: film thickness, (dry) 0.003 inches minimum, gloss (per ASTM D523, 60°F / 16°C): 60, Hardness: H-2H Pencil hardness.
3. Evaporator fan compartment interior cabinet insulation shall conform to AHRI Standards 210/240 minimum exterior sweat criteria. Interior surfaces shall be insulated with a minimum 3/4-in. thick, 1 lb. density, flexible fiberglass insulation, aluminum foil-face coated on the air side.
4. Base of unit shall have locations for thru-the-base gas and electrical connections (factory installed or field installed), standard.
5. Base Rail
 - a. Unit shall have base rails on all sides.
 - b. Holes shall be provided in the base rails for rigging shackles to facilitate maneuvering and overhead rigging.
 - c. Holes shall be provided in the base rail for moving the rooftop by fork truck. d. Base rail shall be a minimum of 14 gauge thickness.
6. Condensate pan and connections:
 - a. Shall be a condensate drain pan made of a non-corrosive material. Unit must be installed at a slight angle to allow for complete drainage.
 - b. Shall comply with ASHRAE Standard 62.
 - c. Shall use a 3/4" x 14 NPT drain connection through the side of the drain pan. Connection shall be made per manufacturer's recommendations.
7. Electrical Connections
 - a. All unit power wiring shall enter unit cabinet at a single, factory-prepared, knockout location. b. Thru-the-base capability
 - i. Standard unit shall have a thru-the-base electrical location(s) using a raised, embossed portion of the unit basepan.
 - ii. No basepan penetration, other than those authorized by the manufacturer, is permitted.
8. Component access panels (standard)
 - a. Cabinet panels shall be easily removable for servicing.
9. Gas Connections:
 - a. All gas piping connecting to unit gas valve shall enter the unit cabinet at a single location on side of unit (horizontal plane).
 - b. Thru-the-base capability
 - i. Standard unit shall have a thru-the-base gas-line location using a raised, embossed portion of the unit basepan.
 - ii. No basepan penetration, other than those authorized by the manufacturer, is permitted.

23 81 19.13.I. Gas Heat

1. General
 - a. Heat exchanger shall be an induced draft design. Positive pressure heat exchanger designs shall not be allowed.
 - b. Shall incorporate a direct-spark ignition system and redundant main gas valve.
 - c. Heat exchanger design shall allow combustion process condensate to gravity drain; maintenance to drain the gas heat exchanger shall not be required.
 - d. Gas supply pressure at the inlet to the rooftop unit gas valve must match that required by the manufacturer.
2. The heat exchanger shall be controlled by an integrated furnace controller (IFC) microprocessor.
 - a. IFC board shall notify users of fault using an LED (light-emitting diode).
3. Standard Heat Exchanger construction
 - a. Heat exchanger shall be of the tubular-section type constructed of a minimum of 20-gauge aluminum coated steel for corrosion resistance.
 - b. Burners shall be of the in-shot type constructed of aluminum-coated steel.
 - c. Burners shall incorporate orifices for rated heat output up to 2000 ft (610m) elevation. Additional accessory kits may be required for applications above 2000 ft (610m) elevation, depending on local gas supply conditions.
4. Optional Stainless Steel Heat Exchanger construction
 - a. Use energy saving, direct-spark ignition system.
 - b. Use a redundant main gas valve.
 - c. Burners shall be of the in-shot type constructed of aluminum-coated steel.
 - d. All gas piping shall enter the unit cabinet at a single location on side of unit (horizontal plane).
 - e. The optional stainless steel heat exchanger shall be of the tubular-section type, constructed of a minimum of 20-gauge type 409 stainless steel.
 - f. Type 409 stainless steel shall be used in heat exchanger tubes and vestibule plate. g. Complete stainless steel heat exchanger allows for greater application flexibility.
5. Induced draft combustion motors and blowers
 - a. Shall be a direct-drive, single inlet, forward-curved centrifugal type. b. Shall be made from steel with a corrosion-resistant finish.
 - c. Shall have permanently lubricated sealed bearings. d. Shall have inherent thermal overload protection.
 - e. Shall have an automatic reset feature.

23 81 19.13.J. Coils

1. Aluminum MicroChannel evaporator and condenser coils on all models.
 - a. Shall have aluminum lanced fins thermally bonded to aluminum multi-port flat tube design (microchannel) tubes. Coils shall be furnace brazed and contain epoxy lined shrink wrap on all aluminum to copper connections.
 - b. Shall be leak tested using helium mass spectrometry. The leak rate shall not exceed 6.5 x 10 sccs of 100% helium at 200 psig, and qualified to UL 1995 burst test at 1950 psig.
 - c. Evaporator coil includes internal distributor plate to prevent mal-distribution of two-phase refrigerant.

23 81 19.13.K. Refrigerant Components

1. Refrigerant circuit shall include the following control, safety, and maintenance features:
 - a. Thermal Expansion Valves (TXV). b. Refrigerant filter drier.
 - c. Service gauge connections on suction and liquid lines.
 - d. External pressure gauge ports access shall be located in front exterior of cabinet.
2. Compressors
 - a. Unit shall use one fully hermetic, scroll compressor.
 - b. Compressor motors shall be cooled by refrigerant gas passing through motor windings.
 - c. Compressors shall be internally protected from high discharge temperature conditions.
 - d. Compressors shall be protected from an over-temperature and over-ampereage conditions by an internal, motor overload device.
 - e. Compressor shall be factory mounted on rubber grommets.
 - f. Compressor motors shall have internal line break thermal and current overload protection along with high pressure differential protection.
 - g. Crankcase heaters shall not be required for normal operating range.

23 81 19.13.L. Filter Section

1. Filters access is specified in the unit cabinet section of this specification.
2. Shall consist of factory-installed, low velocity, throw-away 1-in. thick fiberglass filters.
3. Filter face velocity shall not exceed 365 fpm at nominal airflows.
4. Filters shall be standard, commercially available sizes.
5. Only one size filter per unit is allowed.
6. Filter rack will also accept 2-in thick fiberglass filters of commercially available sizes by removal of a tab.

23 81 19.13.M. Evaporator Fan and Motor

1. Evaporator fan motor:
 - a. Shall have permanently lubricated bearings.
 - b. Shall have inherent automatic-reset thermal overload protection.
 - c. Shall have a maximum continuous bhp rating for continuous duty operation; no safety factors above that rating shall be required.

2. Belt-driven Evaporator Fan:
 - a. Belt drive shall include an adjustable-pitch motor pulley.
 - b. Shall use sealed, permanently lubricated ball-bearing type.
 - c. Blower fan shall be double-inlet type with forward-curved blades.
 - d. Shall be constructed from steel with a corrosion resistant finish and dynamically balanced.
3. High-Static Belt-driven Evaporator Fan Motor(s) and Drive(s):
 - a. High-static motor(s) and drive(s) shall be factory-installed to provide additional performance range.
- 23 81 19.13.N. Condenser Fans and Motors
 1. Condenser fan motors:
 - a. Shall be a totally enclosed motor.
 - b. Shall use permanently lubricated bearings.
 - c. Shall have inherent thermal overload protection with an automatic reset feature.
 - d. Shall use a shaft-down design. Shaft-up designs including those with “rain-slinger devices” shall not be allowed.
 2. Condenser Fans shall:
 - a. Shall be a direct-driven propeller type fan
 - b. Shall have aluminum blades riveted to corrosion-resistant steel spiders and shall be dynamically balanced.
- 23 81 19.13.O. Special Features
 1. Integrated Economizers:
 - a. Integrated, gear-driven parallel modulating blade design type capable of simultaneous economizer and compressor operation.
 - b. Module designed for vertical or horizontal return configurations. Vertical return configuration shall be available as a factory installed option.
 - c. Damper blades shall be galvanized steel with metal gears. Plastic or composite blades on intake or return shall not be acceptable.
 - d. Shall include all hardware and controls to provide free cooling with outdoor air when temperature and/or humidity are below setpoints.
 - e. Shall be equipped with gear driven dampers for both the outdoor ventilation air and the return air for positive air stream control.
 - f. Shall be capable of introducing up to 100% outdoor air.
 - g. Shall be equipped with a barometric relief damper capable of relieving up to 100% return air. The barometric relief damper shall include seals, hardware and hoods to relieve building pressure. Damper shall gravity close upon unit shut down.
 - h. Shall be designed to close damper(s) during loss-of-power situations with spring return built into motor.
 - i. An outdoor single-enthalpy sensor shall be provided as standard. Outdoor air enthalpy set point shall be adjustable and shall range from the enthalpy equivalent of 59.2°F @ 50% rh to 74.8°F @ 50% rh. Additional sensor options shall be available as accessories.
 - j. The economizer controller shall also provide control of an accessory power exhaust unit function. Factory set at 50%, with a range of 0% to 100%.
 - k. The economizer shall maintain minimum airflow into the building during occupied period and provide design ventilation rate for full occupancy.
 - l. Economizer controller shall accept a 2-10Vdc CO₂ sensor input over a CO₂ range of 0-2000 ppm for IAQ/DCV control. In this mode, dampers shall modulate the outdoor-air damper to provide ventilation based on the sensor input.
 - m. Actuator shall be direct coupled to economizer gear. No linkage arms or control rods shall be acceptable.
 - n. Economizer controller shall provide indications when in free cooling mode, in the DCV mode, or the exhaust fan contact is closed.
 - o. Equipped with 3rd party certified low leakage dampers with maximum damper leakage rate to be equal to or less than 4.0 cfm/sq. ft. at 1.0 in. w.g., meeting or exceeding ASHRAE 90.1 requirements. p. Economizer controller on electro-mechanical units shall be Honeywell W7220 that provides:
 - i. 2-line LCD interface screen for setup, configuration and troubleshooting
 - ii. Onboard fault detection and diagnostics
 - iii. Sensor failure loss of communication identification
 - iv. Automatic sensor detection
 - v. Utilize digital sensors: Dry bulb and Enthalpy
 - vi. Adjustable Compressor lockout setpoint shall open at 35°F and close at 50°F.
 2. Two-Position Damper
 - a. Damper shall be a Two-Position Damper. Damper travel shall be from the full closed position to the field adjustable %-open setpoint.
 - b. Damper shall include adjustable damper travel from 25% to 100% (full open).
 - c. Damper shall include single or dual blade, gear driven damper and actuator motor.
 - d. Actuator shall be direct coupled to economizer gear. No linkage arms or control rods shall be acceptable.
 - e. Damper will admit up to 100% outdoor air for applicable rooftop units.
 - f. Damper shall close upon indoor (evaporator) fan shutoff and/or loss of power.
 - g. The damper actuator shall plug into the rooftop unit’s wiring harness plug. No hard wiring shall be required.
 - h. Outside air hood shall include aluminum water entrainment filter.

3. Manual damper
 - a. Manual damper package shall consist of damper, air inlet screen, and rain hood which can be preset to admit up to 50% outdoor air for year round ventilation.
4. Head Pressure Control Package
 - a. Controller shall control coil head pressure by condenser-fan cycling.
5. Condenser Coil Hail Guard Assembly
 - a. Shall protect against damage from hail. b. Shall be louvered design.
6. Thru-the-Base Connectors:
 - a. Kits shall provide connectors to permit gas and electrical connections to be brought to the unit through the unit basepan.
7. Propeller Power Exhaust:
 - a. Power exhaust shall be used in conjunction with an integrated economizer.
 - b. Independent modules for vertical or horizontal return configurations shall be available. c. Horizontal power exhaust shall be mounted in return ductwork.
 - d. Power exhaust shall be controlled by economizer controller operation. Exhaust fans shall be energized when dampers open past the 0-100% adjustable setpoint on the economizer control.
8. Roof Curbs (Vertical):
 - a. Full perimeter roof curb with exhaust capability providing separate airstreams for energy recovery from the exhaust air without supply air contamination.
 - b. Formed galvanized steel with wood nailer strip and shall be capable of supporting entire unit weight.
 - c. Permits installation and securing of ductwork to curb prior to mounting unit on the curb.
9. Outdoor Air Enthalpy Sensor:
 - a. The outdoor air enthalpy sensor shall be used to provide single enthalpy control. When used in conjunction with a return air enthalpy sensor, the unit will provide differential enthalpy control. The sensor allows the unit to determine if outside air is suitable for free cooling.
10. Return Air Enthalpy Sensor:
 - a. The return air enthalpy sensor shall be used in conjunction with an outdoor air enthalpy sensor to provide differential enthalpy control.
11. Indoor Air Quality (CO₂) Sensor:
 - a. Shall be able to provide demand ventilation indoor air quality (IAQ) control.
 - b. The IAQ sensor shall be available in wall mount with LED display. The set point shall have adjustment capability.
 - c. The sensor shall provide a 2-10Vdc output for a CO₂ input range of 0-2000 ppm.
12. Smoke detectors:
 - a. Shall be a Four-Wire Controller and Detector.
 - b. Shall be environmental compensated with differential sensing for reliable, stable, and drift-free sensitivity.
 - c. Shall use magnet-activated test/reset sensor switches.
 - d. Shall have a recessed momentary switch for testing and resetting the detector. e. Controller shall include:
 - i One set of normally open alarm initiation contacts for connection to an initiating device circuit on a fire alarm control panel
 - ii. Two Form-C auxiliary alarm relays for interface with rooftop unit or other equipment.
 - iii. One Form-C supervision (trouble) relay to control the operation of the Trouble LED on a remote test/reset station.
 - iv. Capable of direct connection to two individual detector modules.
 - v. Can be wired to up to 14 other duct smoke detectors for multiple fan shutdown applications.
13. Non-Powered convenience outlet.
 - a. Outlet shall be powered from a separate 115-120v power source.
 - b. A transformer shall not be included.
 - c. Outlet shall be field-installed and internally mounted with easily accessible 115-v female receptacle.
 - d. Outlet shall include 15 amp GFI receptacle.
 - e. Outlet shall be accessible from outside the unit.
14. Unit-Mounted, Non-Fused Disconnect Switch:
 - a. Switch shall be factory-installed, internally mounted.
 - b. National Electric Code (NEC) and UL approved non-fused switch shall provide unit power shutoff. c. Shall be accessible from outside the unit.
 - d. Shall provide local shutdown and lockout capability.
15. Universal Gas Conversion Kit:
 - a. Package shall contain all the necessary hardware and instructions to convert a standard natural gas unit to operate from 2000-7000 ft (610 to 2134m) elevation with natural gas or from 0-7000 ft (90-2134m) elevation with liquefied propane.
16. Liquid Propane (LP) Conversion Kit
 - a. Package shall contain all the necessary hardware and instructions to convert a standard natural gas unit for use with liquefied propane, up to 2000 ft (610m) elevation.
17. Flue Discharge Deflector:
 - a. Flue discharge deflector shall direct unit exhaust vertically instead of horizontally.
 - b. Deflector shall be defined as a “natural draft” device by the National Fuel and Gas (NFG) code.

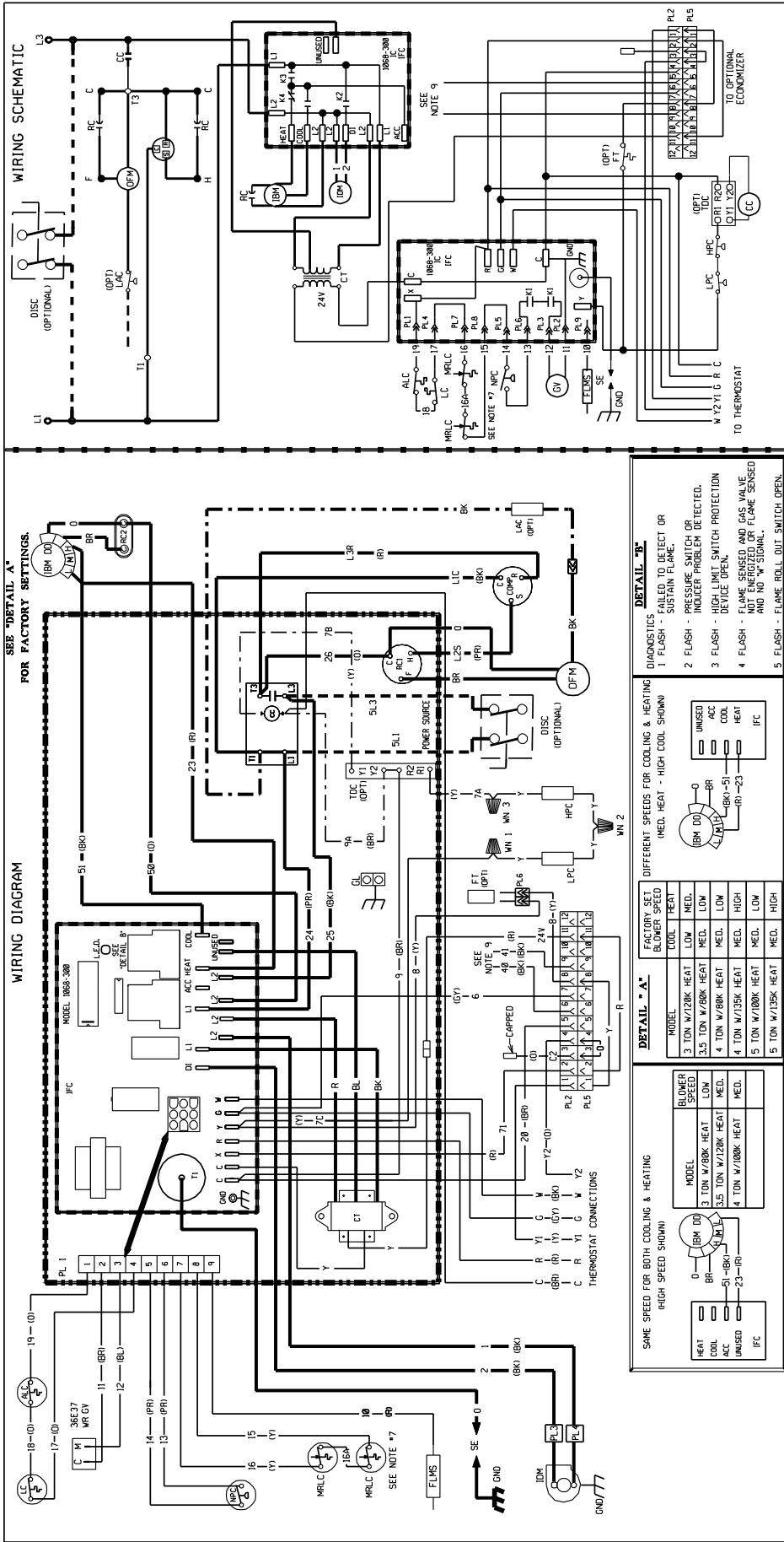

WIRE COLOR CODE

BK...BLACK
BR...BROWN
BL...BLUE
GR...GREEN
GY...GRAY
OR...ORANGE
PR...PURPLE
R...RED
W...WHITE
Y...YELLOW

ELECTRICAL WIRING DIAGRAM

208 / 230, 1 PHASE
DIRECT DRIVE

WIRING INFORMATION

LINE VOLTAGE
-FACTORY STANDARD
-FACTORY OPTION
-FIELD INSTALLED
LOW VOLTAGE
-FACTORY STANDARD
-FACTORY OPTION
-FIELD INSTALLED
-REPLACEMENT WIRE
-MUST BE THE SAME SIZE AND TYPE OF INSULATION AS ORIGINAL (105 C. MIN.)

NOTES:

- CONNECTORS SUITABLE FOR USE WITH COPPER CONDUCTORS ONLY.
- COMPRESSOR MOTOR THERMALLY PROTECTED. ALL 3 PHASE MODELS ARE PROTECTED UNDER PRIMARY SINGLE PHASE CONDITIONS.
- CONTROL TRANSFORMER PRIMARY LEADS: RED-COMMON, BLUE-208V, BLACK-230V. TRANSFORMER PRIMARY WIRED FOR 230 VOLTS. INTERCHANGE BLACK FOR BLUE LEADS FOR 208V OPERATION.
- SUPPLIED CONTACTOR IN ELECTRICAL BOX.
- LOW VOLTAGE CIRCUIT IS N.E.C. CLASS 2 WITH A CLASS 2 TRANSFORMER, 24V, 50/60 HZ SUPPLIED.
- CONNECT FIELD WIRING IN GROUNDED RAIN TIGHT CONDUIT TO 60 HZ FUSED DISCONNECT.
- ONLY ONE MRLC IS NEEDED ON THE 90000 INPUT UNIT.
- ONLY ONE MRLC IS NEEDED TO BE CONNECTED TO THE MIXED AIR SENSOR ON THE OPTIONAL ECONOMIZER.
- WIRES FROM PL 16 IS 9/60 TO THE MIXED AIR SENSOR ON THE OPTIONAL ECONOMIZER.
- 10.12 IS USED ONLY FOR THE OPTIONAL ECONOMIZER.

COMPONENT CODE

AUX. LIMIT CONTROL
CC COMPRESSOR CONTACTOR
CMP COMPRESSOR
CTC DISCONNECT SWITCH
FLMS FLAME SENSOR
FT FREEZE STAT
GL GROUND LUG
GND GROUND
GV GAS VALVE
HPC HIGH PRESSURE CONTROL
IBM INDOOR BLOWER MOTOR
IDM INDUCED DRAFT MOTOR
IFC INTERGRATED FURNACE CONTROL
LAC LOW AMBIENT COOLING CONTROL
LCC LIMIT CONTROL
LPC LOW PRESSURE CONTROL
MRLC MANUAL RESET LIMIT CONTROL

NPC NEGATIVE PRESSURE CONTROL
OFM OUTDOOR FAN MOTOR
PL PLUG
RKA RUN CAPACITOR
SC STARTER
TDC TIME DELAY CONTROL
WN WIRE NUT

DETAIL A

MODEL	BLOWER SPEED	COOL	HEAT
3 TON W/728K HEAT	LOW	MED.	MED.
3.5 TON W/80K HEAT	LOW	MED.	LOW
4 TON W/80K HEAT	MED.	LOW	MED.
4 TON W/135K HEAT	MED.	MED.	HIGH
5 TON W/100K HEAT	MED.	MED.	LOW
5 TON W/135K HEAT	MED.	MED.	HIGH

DETAIL B

MODEL	BLOWER SPEED	COOL	HEAT
3 TON W/80K HEAT	LOW	MED.	MED.
3.5 TON W/128K HEAT	LOW	MED.	LOW
4 TON W/100K HEAT	MED.	LOW	MED.
4 TON W/135K HEAT	MED.	MED.	HIGH

DETAIL C

MODEL	BLOWER SPEED	COOL	HEAT
3 TON W/80K HEAT	LOW	MED.	MED.
3.5 TON W/128K HEAT	LOW	MED.	LOW
4 TON W/100K HEAT	MED.	LOW	MED.
4 TON W/135K HEAT	MED.	MED.	HIGH

DETAIL D

MODEL	BLOWER SPEED	COOL	HEAT
3 TON W/80K HEAT	LOW	MED.	MED.
3.5 TON W/128K HEAT	LOW	MED.	LOW
4 TON W/100K HEAT	MED.	LOW	MED.
4 TON W/135K HEAT	MED.	MED.	HIGH

DETAIL E

MODEL	BLOWER SPEED	COOL	HEAT
3 TON W/80K HEAT	LOW	MED.	MED.
3.5 TON W/128K HEAT	LOW	MED.	LOW
4 TON W/100K HEAT	MED.	LOW	MED.
4 TON W/135K HEAT	MED.	MED.	HIGH

DETAIL F

MODEL	BLOWER SPEED	COOL	HEAT
3 TON W/80K HEAT	LOW	MED.	MED.
3.5 TON W/128K HEAT	LOW	MED.	LOW
4 TON W/100K HEAT	MED.	LOW	MED.
4 TON W/135K HEAT	MED.	MED.	HIGH

DETAIL G

MODEL	BLOWER SPEED	COOL	HEAT
3 TON W/80K HEAT	LOW	MED.	MED.
3.5 TON W/128K HEAT	LOW	MED.	LOW
4 TON W/100K HEAT	MED.	LOW	MED.
4 TON W/135K HEAT	MED.	MED.	HIGH

DETAIL H

MODEL	BLOWER SPEED	COOL	HEAT
3 TON W/80K HEAT	LOW	MED.	MED.
3.5 TON W/128K HEAT	LOW	MED.	LOW
4 TON W/100K HEAT	MED.	LOW	MED.
4 TON W/135K HEAT	MED.	MED.	HIGH

DETAIL I

MODEL	BLOWER SPEED	COOL	HEAT
3 TON W/80K HEAT	LOW	MED.	MED.
3.5 TON W/128K HEAT	LOW	MED.	LOW
4 TON W/100K HEAT	MED.	LOW	MED.
4 TON W/135K HEAT	MED.	MED.	HIGH

DETAIL J

MODEL	BLOWER SPEED	COOL	HEAT
3 TON W/80K HEAT	LOW	MED.	MED.
3.5 TON W/128K HEAT	LOW	MED.	LOW
4 TON W/100K HEAT	MED.	LOW	MED.
4 TON W/135K HEAT	MED.	MED.	HIGH

DETAIL K

MODEL	BLOWER SPEED	COOL	HEAT
3 TON W/80K HEAT	LOW	MED.	MED.
3.5 TON W/128K HEAT	LOW	MED.	LOW
4 TON W/100K HEAT	MED.	LOW	MED.
4 TON W/135K HEAT	MED.	MED.	HIGH

DETAIL

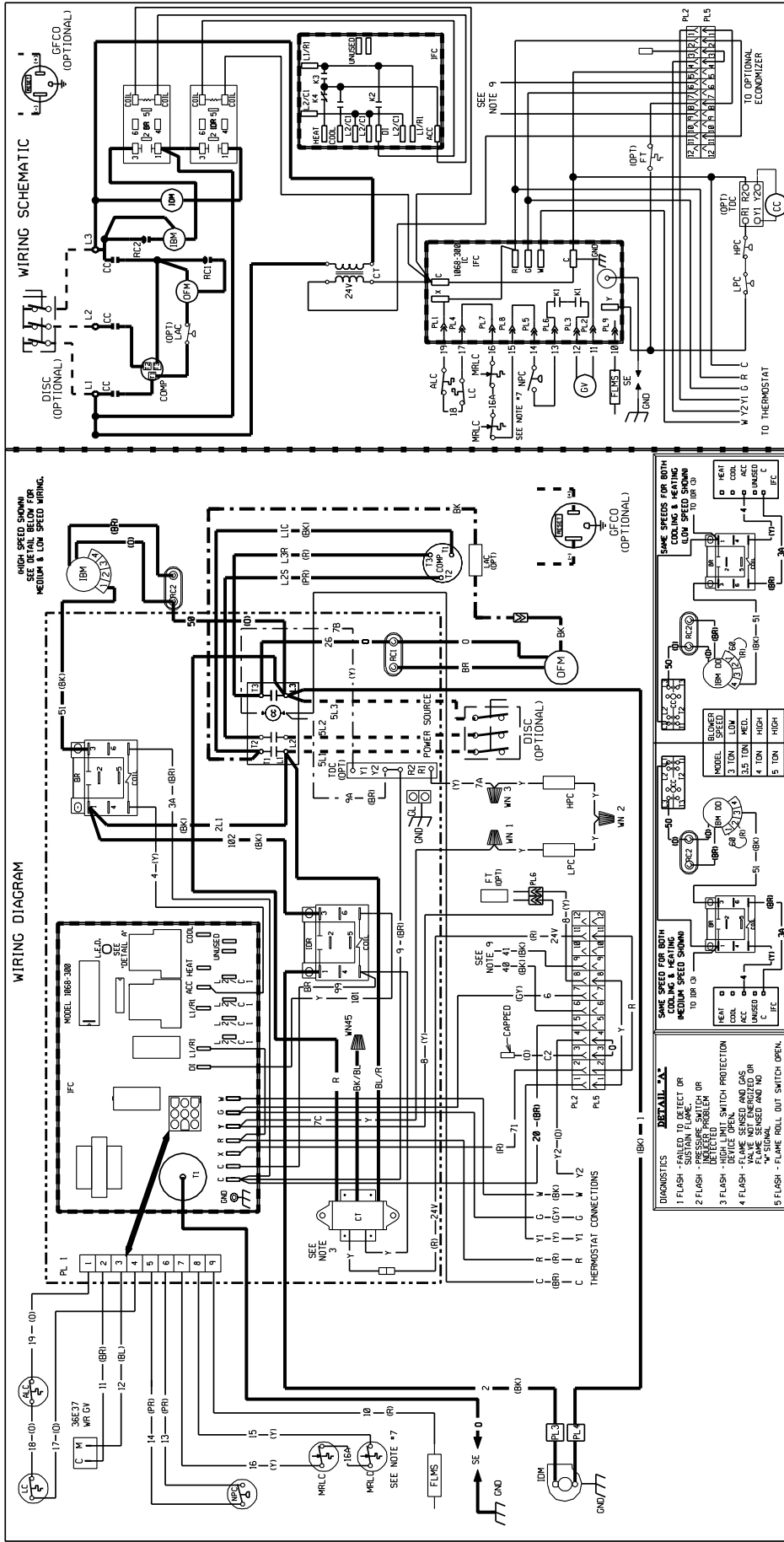

WIRE COLOR CODE

BK	BLACK
BR	BROWN
BL	BLUE
G	GREEN
GY	GRAY
O	ORANGE
PR	PURPLE
R	RED
W	WHITE
Y	YELLOW

ELECTRICAL WIRING DIAGRAM
460, 3 PHASE, 60 HZ
DIRECT DRIVE
ROOF TOP

WIRING INFORMATION

LINE VOLTAGE
-FACTORY STANDARD
-FACTORY OPTION
-FIELD INSTALLED
LOW VOLTAGE
-FACTORY STANDARD
-FACTORY OPTION
-FIELD INSTALLED
REPLACEMENT WIRE

MUST BE THE SAME SIZE AND TYPE OF INSULATION AS ORIGINAL (105 C. MIN.)
WARNING
-CABINET MUST BE PERMANENTLY GROUNDED AND CONFORM TO I.E.C., N.E.C., C.E.C., NATIONAL WIRING REGULATIONS, AND LOCAL CODES AS APPLICABLE.

- NOTES:**
- CONNECTORS SUITABLE FOR USE WITH COPPER CONDUCTORS ONLY.
 - COMPRESSOR MOTOR THERMALLY PROTECTED. ALL 3 PHASE MODELS ARE PROTECTED UNDER PRIMARY SINGLE PHASE CONDITIONS.
 - POWER TRANSFORMER PRIMARY LEADS BLUE-COMMON BK/RED-460V, 60 HZ, 7.388V, 50 HZ, 4.24 RED/57V, 60 HZ, 7.415V, 50 HZ.
 - CONTACTOR FACTORY WIRED. CONNECT FIELD WIRE TO FACTORY SUPPLIED CONTACTOR IN ELECTRICAL BOX.
 - LOW VOLTAGE CIRCUIT IS N.E.C. CLASS 2 WITH A CLASS 2 TRANSFORMER, 24V/50/60 HZ SUPPLIED.
 - CONNECT FIELD WIRING IN GROUNDED RAIN TIGHT CONDUIT TO 60 HZ CUSED DISCONNECT.
 - ONLY ONE MRLC IS NEEDED ON THE 60,000 INPUT UNIT. WIRES FROM PLZ (6 & 9) TO THE MIXED AIR SENSOR ON THE OPTIONAL ECONOMIZER.
 - Y2 IS USED ONLY FOR THE OPTIONAL ECONOMIZER.

COMPONENT CODE

ALC	AUX LIMIT CONTROL
BC	BLOWER CONTACTOR
CC	COMPRESSOR CONTACTOR
COMP	COMPRESSOR
CT	CONTROL TRANSFORMER
DISC	DISCONNECT SWITCH
FLMS	FLAME SENSOR
FT	FREEZE STAT
GFCO	GROUND FAULT CONVENIENCE OUTLET
GL	GROUND LUG
GND	GROUND
LPC	LOW VOLTAGE PRESSURE CONTROL
IBM	INDUCED BLOWER MOTOR
IDM	INDUCED DRAFT MOTOR
IDR	INDUCED DRAFT RELAY
IFC	INTERGRADED FURNACE CONTROL
LAC	LOW AMBIENT COOLING CONTROL
LC	LIMIT CONTROL
LPC	LOW PRESSURE CONTROL
MRLC	MANUAL RESET LIMIT CONTROL
NPC	NEGATIVE PRESSURE CONTROL
OFM	OUTDOOR FAN MOTOR
PL	PLUG
PT	POWER TRANSFORMER
RC	RUN CAPACITOR
SD	SMOKE DETECTOR
SE	SPARK ELECTRODE
TDC	TIME DELAY CONTROL
WN	WIRE NUT
Y2	GAS VALVE
Y1	PRESSURE CONTROL
Y3	INDUCED BLOWER MOTOR
Y4	INDUCED DRAFT MOTOR
Y5	INDUCED DRAFT RELAY
Y6	INTERGRADED FURNACE CONTROL
Y7	LOW AMBIENT COOLING CONTROL

DIAGNOSTICS

- FLASH - SYSTEM FLAME
- FLASH - PRESSURE SWITCH OR PRESSURE PROBLEM DETECTED
- FLASH - HIGH LIMIT SWITCH PROTECTION
- FLASH - FLAME SENSED AND GAS VALVE NOT ENERGIZED OR "W" SIGNAL
- FLASH - FLAME ROLL OUT SWITCH OPEN

DETAIL "A"

SAVE SPEED FOR BOTH COOLING & HEATING
LOW SPEED SHOWN TO 100 C.P.

SAVE SPEED FOR BOTH COOLING & HEATING
LOW SPEED SHOWN TO 100 C.P.

BLOWER SPEED

3 TON	1500
3.5 TON	1500
4 TON	1500
4.5 TON	1500
5 TON	1500

DR. BY: APP. BY: DATE: 2-11-13
MGR: DWG. NO.: 90-23596-42
REV: 01

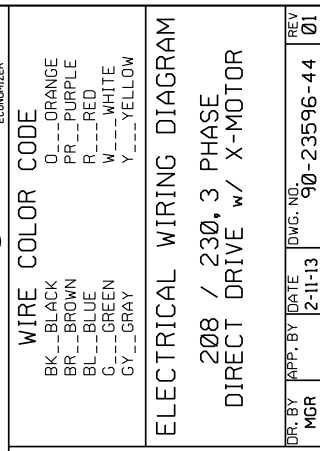
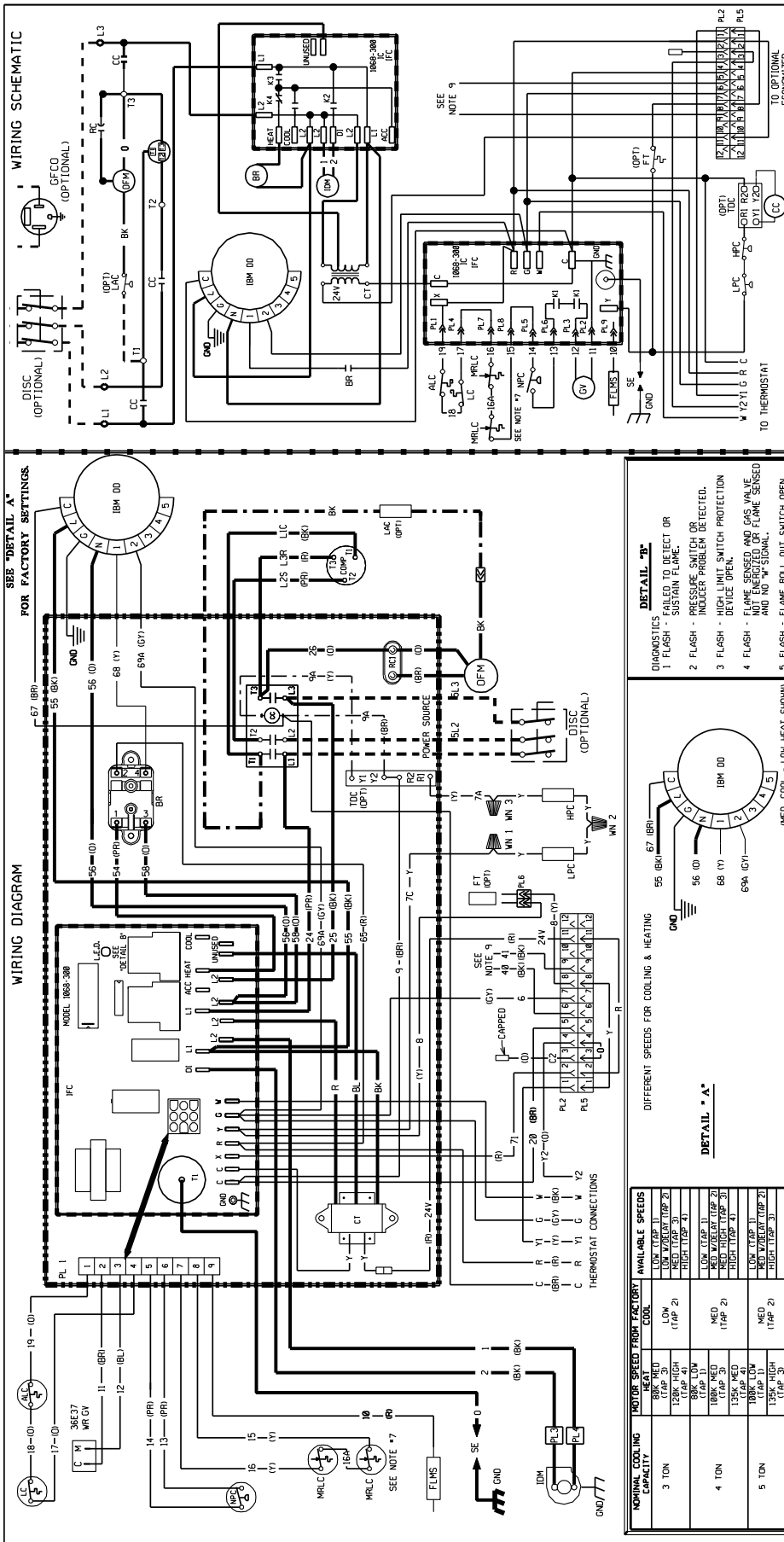

WIRING SCHEMATIC

DISC (OPTIONAL)
GFCO (OPTIONAL)

WIRE COLOR CODE

BK...BLACK
BR...BROWN
BL...BLUE
G...GREEN
GY...GRAY
O...ORANGE
PR...PURPLE
R...RED
W...WHITE
Y...YELLOW

ELECTRICAL WIRING DIAGRAM

208 / 230, 3 PHASE
DIRECT DRIVE w/ X-MOTOR

DR. BY APP. BY DATE DWG. NO. REV
MGR 2-11-13 90-23596-44 01

WIRING INFORMATION

LINE VOLTAGE
-FACTORY STANDARD
-FIELD INSTALLED
-FACTORY STANDARD
-FIELD INSTALLED
-REPLACEMENT WIRE
-MUST BE THE SAME SIZE AND TYPE OF INSULATION AS ORIGINAL (105 C-MIN.)
-CABINET MUST BE PERMANENTLY GROUNDED AND CONFORM TO I.E.C., N.E.C., C.E.C. NATIONAL WIRING REGULATIONS, AND LOCAL CODES AS APPLICABLE.

DETAIL - 2*

DIAGNOSTICS - FAILED TO DETECT OR SUSTAIN FLAME.
1 FLASH - PRESSURE SWITCH OR INDUCER PROBLEM DETECTED.
2 FLASH - HIGH LIMIT SWITCH PROTECTION DEVICE OPEN.
3 FLASH - FLAME SENSED AND GAS VALVE AND NO. 122 OPEN.
4 FLASH - FLAME ROLL-OUT SWITCH OPEN.

NOTES:

- CONNECTORS SUITABLE FOR USE WITH COPPER CONDUCTORS ONLY.
- COMPRESSOR MOTOR THERMALLY PROTECTED. ALL 3 PHASE MODELS ARE PROTECTED UNDER PRIMARY SINGLE PHASE CONDITIONS.
- CONTROL TRANSFORMER PRIMARY LEADS: RED-COMMON, BLUE-208V, INTERCHANGE BLACK FOR BLUE LEADS FOR 208V OPERATION.
- FACTORY WIRE TO FACTORY CONNECT FIELD WIRE TO FACTORY SUPPLIED CONTACTOR IN ELECTRICAL BOX.
- LOW VOLTAGE CIRCUIT IS M.E.C. CLASS 2 WITH A CLASS 2 TRANSFORMER, 24V.50/60 HZ SUPPLIED.
- CONNECT FIELD WIRING IN GROUNDED RAIN TIGHT CONDUIT TO 60 HZ INDUCER BLOWER MOTOR DIRECT DRIVE UNIT.
- ONLY ONE MRLC IS NEEDED ON THE 90/000 INPT UNIT.
- WIRES FROM PL2 (6 & 9) GO TO THE MIXED AIR SENSOR ON THE OPTIONAL ECONOMIZER.
- 10, 12 IS USED ONLY FOR THE OPTIONAL ECONOMIZER.

COMPONENT CODE

ALC AUX LIMIT CONTROL
BR BLOWER BELLOWS CONTROL
CC COMPRESSOR CONTACTOR
COMP CONTROL TRANSFORMER
CT FUSE
FLMS FREEZE STAT
FT FROST STAT
GND GROUND LUG
DL DRAIN LUG
GV GAS VALVE
HPC HIGH PRESSURE CONTROL
IBM INDUCER BLOWER MOTOR DIRECT DRIVE
IDM INDUCED DRAFF FLAME CONTROL
LAC LOW AMBIENT COOLING CONTROL
LPC LIMIT CONTROL
MRLC MANUAL RESET LIMIT CONTROL

NOMINAL COOLING CAPACITY	MOTOR SPEED FROM FACTORY	AVAILABLE SPEEDS		
		CODE	LOW (TAP 1)	HIGH (TAP 2)
3 TON	88K MED (TAP 3)	LOW (TAP 1)	MED (TAP 2)	HIGH (TAP 3)
	120K HIGH (TAP 2)	LOW (TAP 1)	MED (TAP 2)	HIGH (TAP 3)
	MED (TAP 3)	LOW (TAP 1)	MED (TAP 2)	HIGH (TAP 3)
4 TON	88K LOW (TAP 3)	LOW (TAP 1)	MED (TAP 2)	HIGH (TAP 3)
	135K MED (TAP 2)	LOW (TAP 1)	MED (TAP 2)	HIGH (TAP 3)
	100K HIGH (TAP 1)	LOW (TAP 1)	MED (TAP 2)	HIGH (TAP 3)
5 TON	135K HIGH (TAP 2)	LOW (TAP 1)	MED (TAP 2)	HIGH (TAP 3)
	100K LOW (TAP 1)	LOW (TAP 1)	MED (TAP 2)	HIGH (TAP 3)
	135K MIGHT (TAP 3)	LOW (TAP 1)	MED (TAP 2)	HIGH (TAP 3)

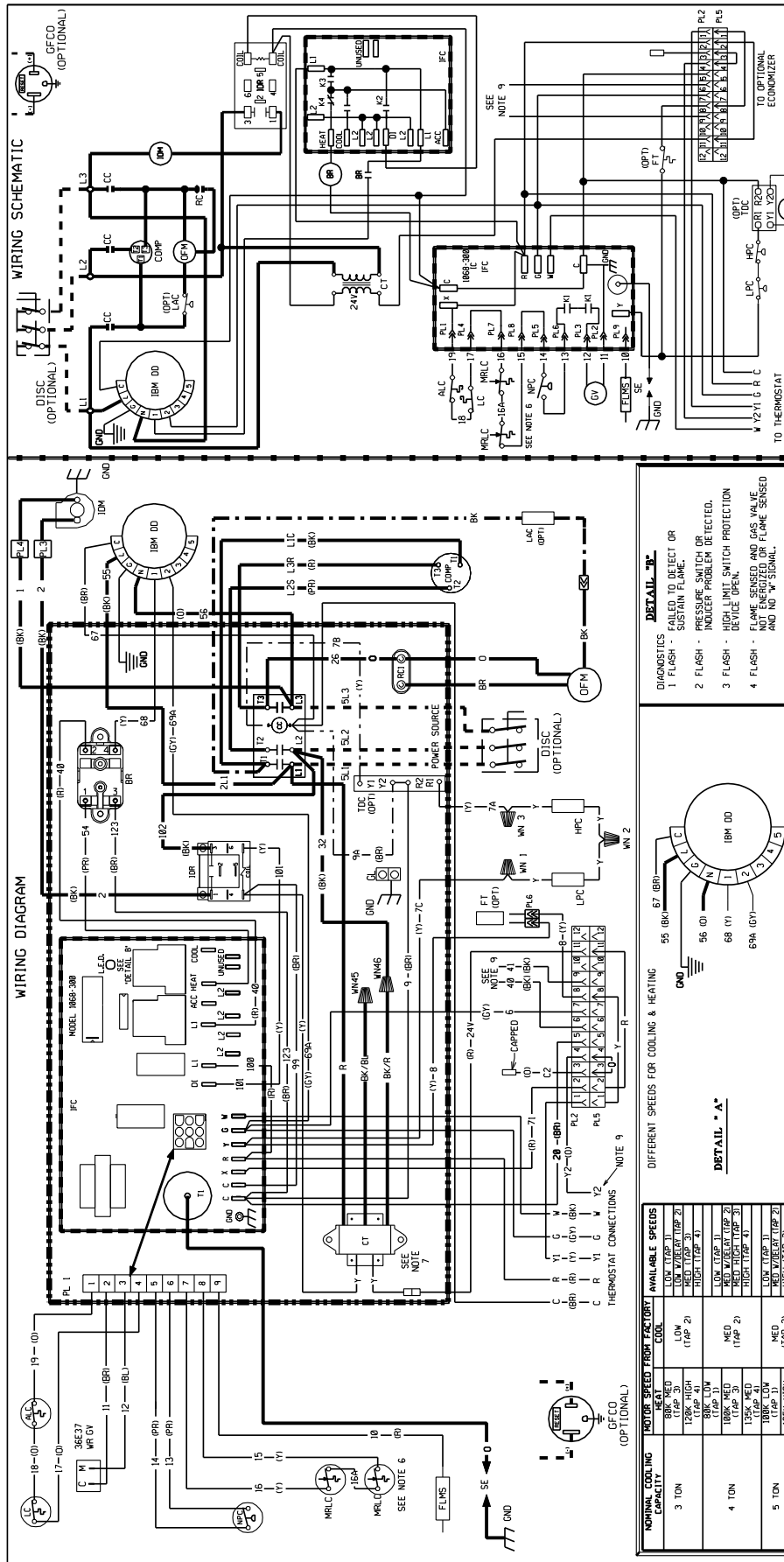

WIRE COLOR CODE

BK	BLACK
BR	BROWN
BL	BLUE
G	GREEN
GY	GRAY
O	ORANGE
PR	PURPLE
R	RED
W	WHITE
Y	YELLOW

ELECTRICAL WIRING DIAGRAM

460V X-DRIVE MOTOR
DIRECT DRIVE BLOWER

DR. BY: MGR APP. BY: DATE: 2-11-13 DWG. NO.: 90-23596-46 REV: 01

WIRING INFORMATION

LINE VOLTAGE
-FACTORY STANDARD
-FIELD INSTALLED
LOW VOLTAGE
-FACTORY STANDARD
-FIELD INSTALLED
REPLACEMENT WIRE
-MUST BE THE SAME SIZE AND TYPE OF INSULATION AS ORIGINAL (105 C-MIN.)
-CABINET MUST BE PERMANENTLY GROUNDED AND CONFORM TO I.E.C., N.E.C., C.E.C., NATIONAL WIRING REGULATIONS, AND LOCAL CODES AS APPLICABLE.

NOTES:

- CONNECTORS SUITABLE FOR USE WITH COPPER CONDUCTORS ONLY.
- COMPRESSOR MOTOR THERMALLY PROTECTED. ALL 3 PHASE MODELS ARE PROTECTED UNDER PRIMARY SINGLE PHASE CONDITIONS.
- SUPPLIED FACTORY WIRED. CONNECT FIELD WIRE TO FACTORY SUPPLIED FACTORY IN ELECTRICAL BOX.
- LOW VOLTAGE CIRCUIT IS N.E.C. CLASS 2 WITH A CLASS 2 TRANSFORMER, 24V/50/60 HZ SUPPLIED.
- CONNECT FIELD WIRING IN GROUNDED RAIN TIGHT CONDUIT TO 60 HZ FUSED DISCONNECT.
- ONLY ONE MRLC IS NEEDED ON THE 60,000 INPUT UNIT.
- CONTROL TRANSFORMER PRIMARY LEADS BLUE-COMMON/BK/RED-480V, 60 HZ / 380V, 50 HZ; RED-575V, 60 HZ / 415V, 50 HZ. OPTIONAL ECONOMIZER.
- WIRE FROM PL.2 17 & 81 GO TO THE MIXED AIR SENSOR ON THE OPTIONAL ECONOMIZER.
- 12 IS USED ONLY FOR THE OPTIONAL ECONOMIZER.

DETAIL * B *

DIAGNOSTICS
1 FLASH - FAILED TO DETECT OR SUSAN FLAME.
2 FLASH - PRESSURE SWITCH OR PROBLEM DETECTED.
3 FLASH - REFRIG. PRESS. SWITCH PROTECTION
4 FLASH - FLAME SENSED AND GAS VALVE NOT ENERGIZED OR FLAME SENSED AND NO "W" SIGNAL.
5 FLASH - FLAME ROLL OUT SWITCH OPEN.

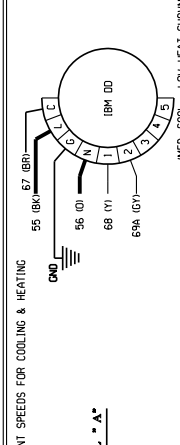

DIFFERENT SPEEDS FOR COOLING & HEATING

NOMINAL COOLING CAPACITY	MOTOR SPEED FROM FACTORY AVAILABLE SPEEDS		
	HEAT (TAP 3)	COOL (TAP 2)	LOW WHEEL (TAP 2)
3 TON	120K HIGH (TAP 3)	120K HIGH (TAP 2)	120K HIGH (TAP 2)
	120K MED (TAP 3)	120K MED (TAP 2)	120K MED (TAP 2)
	120K LOW (TAP 3)	120K LOW (TAP 2)	120K LOW (TAP 2)
4 TON	135K HIGH (TAP 3)	135K HIGH (TAP 2)	135K HIGH (TAP 2)
	135K MED (TAP 3)	135K MED (TAP 2)	135K MED (TAP 2)
	135K LOW (TAP 3)	135K LOW (TAP 2)	135K LOW (TAP 2)
5 TON	150K HIGH (TAP 3)	150K HIGH (TAP 2)	150K HIGH (TAP 2)
	150K MED (TAP 3)	150K MED (TAP 2)	150K MED (TAP 2)
	150K LOW (TAP 3)	150K LOW (TAP 2)	150K LOW (TAP 2)

COMPONENT CODE

ALC	AUX. LIMIT CONTROL
BC	BLOWER CONTACTOR
CC	COMPRESSOR
CD	CONTROL TRANSFORMER
CT	DISCONNECT SWITCH
FLMS	FLAME SENSOR
FT	FREEZE STAT
GF	GROUND FAULT
GL	GROUND LUG
GV	GROUND VALVE
IB	INDOOR BLOWER MOTOR
IDR	INDUCED DRAFT RELAY
IFC	INDUCED FURNACE CONTROL
LAC	LOW AMBIENT COOLING CONTROL
LC	LIMIT CONTROL
MRLC	MANUAL RESET LIMIT CONTROL
MPC	NEGATIVE PRESSURE CONTROL
OFM	OUTDOOR FAN MOTOR
PL	PLUG
RC	RUN CAPACITOR
SD	SMOKE DETECTOR
SE	SPARK ELECTRODE
TDC	TIME DELAY CONTROL
WN	WIRE NUT
IDR	INDUCED DRAFT RELAY
IB	INDOOR BLOWER MOTOR
IFC	INDUCED FURNACE CONTROL
LAC	LOW AMBIENT COOLING CONTROL

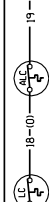
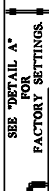
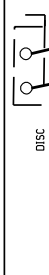
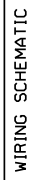
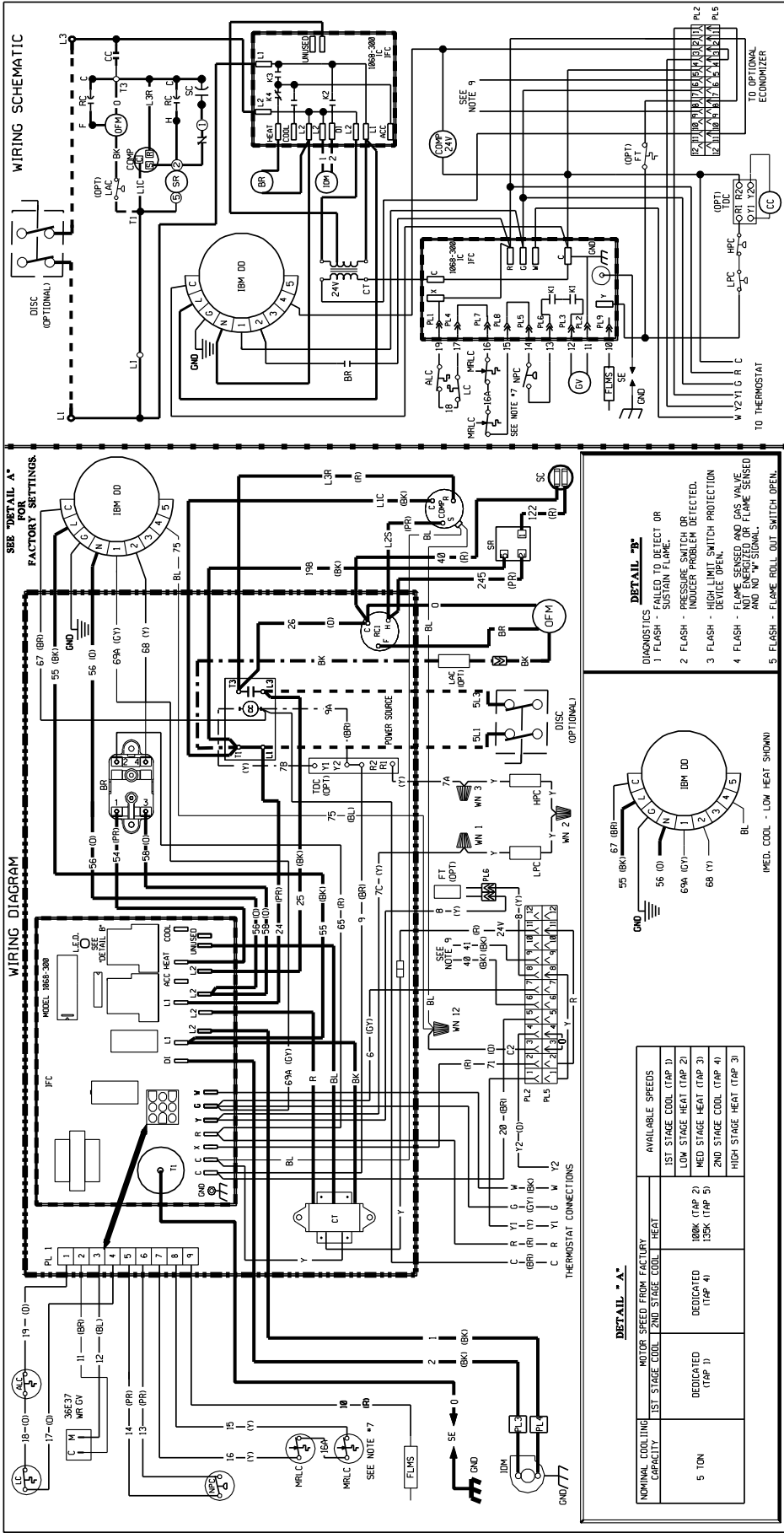

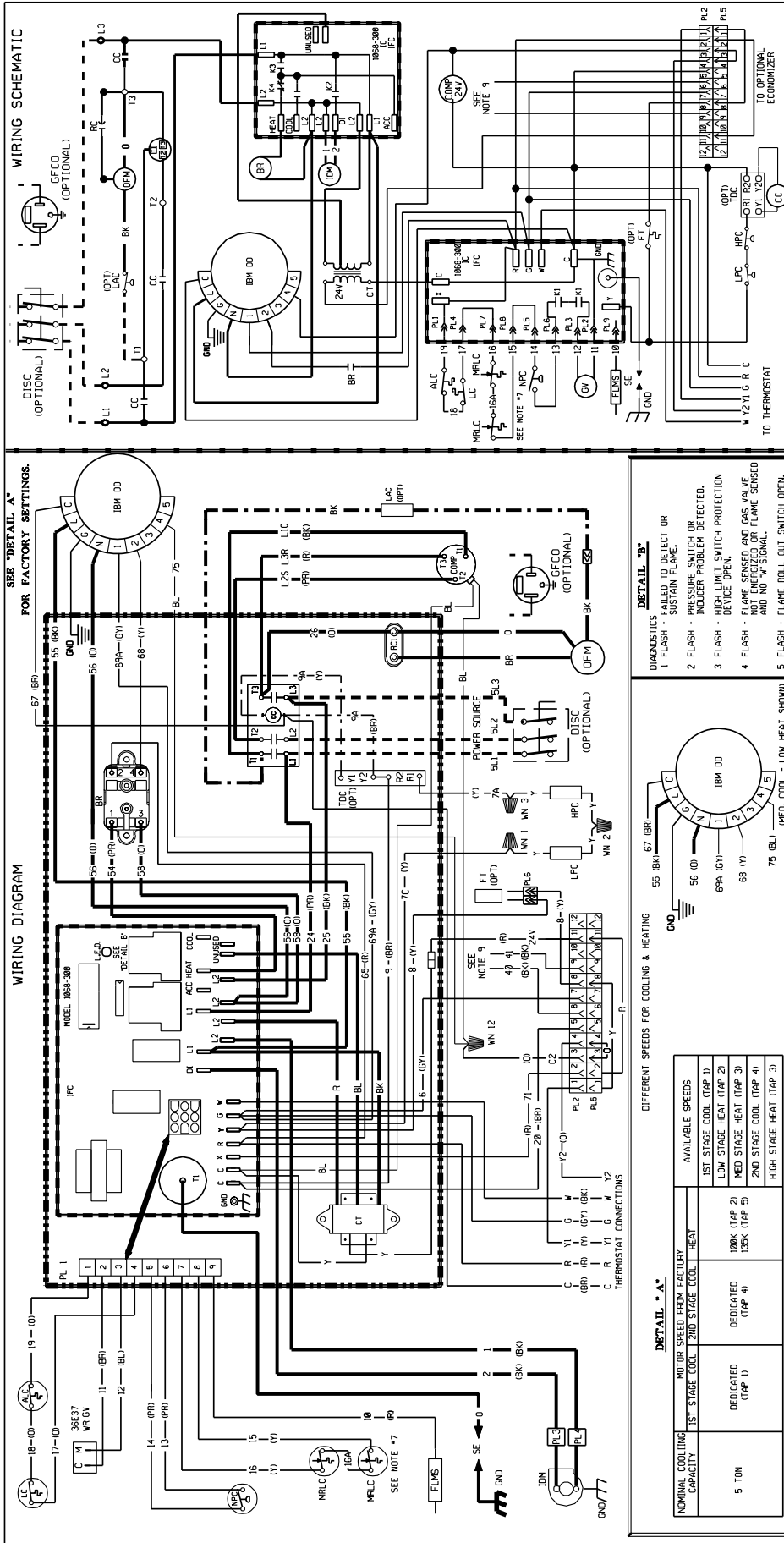

WIRE COLOR CODE

0	ORANGE
BK	BLACK
BR	BROWN
BL	BLUE
G	GREEN
GY	GRAY
W	WHITE
Y	YELLOW

ELECTRICAL WIRING DIAGRAM
 208 / 230, 3 PHASE
 DIRECT DRIVE w/ X-MOTOR
 2-STAGE

DR. BY: MGR APP. BY: DATE: 4-8-13 DWG. NO.: 90-23596-48 REV: 01

WIRING INFORMATION

LINE VOLTAGE
 -FACTORY STANDARD
 -FACTORY OPTION
 -FIELD INSTALLED
 LOW VOLTAGE
 -FACTORY STANDARD
 -FACTORY OPTION
 -FIELD INSTALLED
 REPLACEMENT WIRE
 -MUST BE THE SAME SIZE AND TYPE OF INSULATION AS ORIGINAL (105 C.MIN.)
 -CABINET MUST BE PERMANENTLY GROUNDED AND CONFORM TO I.E.C., N.E.C., C.E.C. NATIONAL WIRING REGULATIONS, AND LOCAL CODES AS APPLICABLE.

NOTES:

- CONNECTORS SUITABLE FOR USE WITH COPPER CONDUCTORS ONLY.
- COMPRESSOR MOTOR THERMALLY PROTECTED. ALL 3 PHASE MODELS ARE PROTECTED UNDER PRIMARY SINGLE PHASE CONDITIONS.
- CONTROL TRANSFORMER PRIMARY LEADS: RED-COMMON, BLUE-208V, INTERCHANGE BLACK FOR BLUE LEADS FOR 208V OPERATION.
- CONTACTOR FACTORY WIRE. CONNECT FIELD WIRE TO FACTORY SUPPLIED CONTACTOR IN ELECTRICAL BOX.
- LOW VOLTAGE CIRCUIT IS N.E.C. CLASS 2 WITH A CLASS 2 CONNECT FIELD WIRING IN GROUNDED RAIN TIGHT CONDUIT TO 60 HZ.
- ONE WIRE MRLC IS REQUIRED ON THE 80,000 INPUT UNIT.
- MOTOR FACTORY WIRE FOR CORRECT SPEED.
- OPTIONAL ECONOMIZER.
- 10.12 IS USED ONLY FOR THE OPTIONAL ECONOMIZER.

COMPONENT CODE

AUX LIMIT CONTROL	NFC
BLOWER RELAY	OPM
COMPRESSOR CONTACTOR	PL
CONDENSER FAN MOTOR	PL
CONTROL TRANSFORMER	PC
FLAME SENSOR	FT
FREZE STAT	FT
GROUND LUG	GL
GROUND	GND
HIGH PRESSURE CONTROL	HPC
INDUCED BLOWER MOTOR DIRECT DRIVE	IBM
INDUCED DRAFT MOTOR	IDM
INTERLOCKED FURNACE CONTROL	IFC
INTERLOCKED COOLING CONTROL	ILC
LIMIT CONTROL	LPC
LOW PRESSURE CONTROL	LPC
MANUAL RESET LIMIT CONTROL	MRLC

DETAIL "B"

DIAGNOSTICS
 1 FLASH - SAILED TO DETECT OR SUSTAIN FLAME.
 2 FLASH - PRESSURE SWITCH OR INDUCER PROBLEM DETECTED.
 3 FLASH - HIGH LIMIT SWITCH PROTECTION DEVICE OPEN.
 4 FLASH - FLAME SENSED AND GAS VALVE NOT ENERGIZED OR FLAME SENSED AND NO "W" SIGNAL.
 5 FLASH - FLAME ROLL OUT SWITCH OPEN.

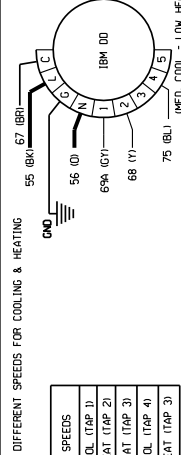

DETAIL "A"

NOMINAL COOLING CAPACITY	MOTOR SPEED FROM FACTORY		AVAILABLE SPEEDS	
	1ST STAGE COOL (TAP 1)	2ND STAGE COOL (TAP 2)	1ST STAGE COOL (TAP 1)	2ND STAGE COOL (TAP 2)
5 TON	DEDICATED (TAP 1)	DEDICATED (TAP 2)	100K (TAP 2)	MED STAGE HEAT (TAP 3)
	DEDICATED (TAP 1)	DEDICATED (TAP 2)	135K (TAP 3)	2ND STAGE COOL (TAP 4)
	DEDICATED (TAP 1)	DEDICATED (TAP 2)	150K (TAP 4)	HIGH STAGE HEAT (TAP 3)
	DEDICATED (TAP 1)	DEDICATED (TAP 2)	165K (TAP 5)	HIGH STAGE HEAT (TAP 3)

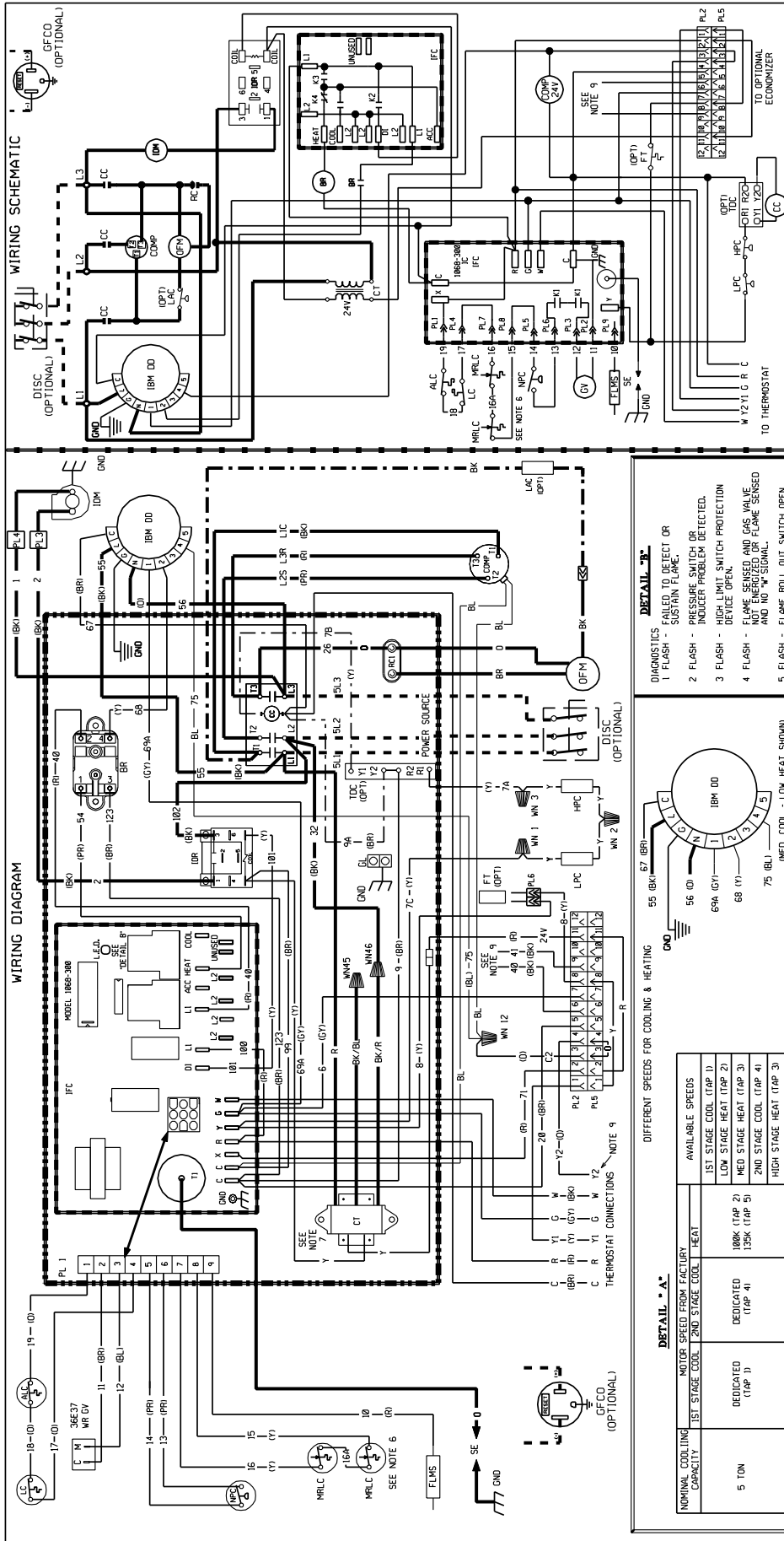

WIRE COLOR CODE

BK	BLACK
BR	BROWN
BL	BLUE
G	GREEN
CY	GRAY
0	ORANGE
PR	PURPLE
R	RED
W	WHITE
Y	YELLOW

ELECTRICAL WIRING DIAGRAM
460V X-DRIVE MOTOR
DIRECT DRIVE BLOWER
2-STAGE

WIRING INFORMATION

LINE VOLTAGE
-FACTORY STANDARD
-FACTORY OPTION
-FIELD INSTALLED
-LOW VOLTAGE
-FACTORY STANDARD
-FACTORY OPTION
-FIELD INSTALLED
REPLACEMENT WIRE
-MUST BE THE SAME SIZE AND TYPE OF INSULATION AS ORIGINAL (105 C.MIN.)
WARNING:
-CABINET MUST BE PERMANENTLY GROUNDED AND CONFORM TO I.E.C., N.E.C., C.E.C., NATIONAL WIRING REGULATIONS, AND LOCAL CODES AS APPLICABLE.

NOTES:

- CONNECTORS SUITABLE FOR USE WITH COPPER CONDUCTORS ONLY.
- COMPRESSOR MOTOR THERMALLY PROTECTED. ALL 3 PHASE MODELS ARE PROTECTED UNDER PRIMARY SINGLE PHASE CONDITIONS.
- CONTROL FACTORY WIRING. CONNECT FIELD WIRE TO FACTORY SUPPLIED CONTACTOR IN ELECTRICAL BOX.
- LOW VOLTAGE CIRCUIT IS N.E.C. CLASS 2 WITH A CLASS 2 TRANSFORMER, 24V/50/60 HZ SUPPLIED.
- FUSED DISCONNECT.
- ONLY ONE MRLC IS NEEDED ON THE 80/200 INPUT UNIT.
- CONTROL TRANSFORMER PRIMARY LEADS: BLUE-COMMON, BK/RED-460V, 60 HZ / 380V, 50 HZ; RED-575V, 60 HZ / 415V, 50 HZ.
- WIRES FROM PL2 (7 & 8) GO TO THE MIXED AIR SENSOR ON THE OPTIONAL ECONOMIZER.
- Y2 IS USED ONLY FOR THE OPTIONAL ECONOMIZER.

COMPONENT CODE

ALC	AUX. LIMIT CONTROL
BC	BLOWER CONTACTOR
CC	COMPRESSOR CONTACTOR
COMP	CONTROL TRANSFORMER
CT	CONTROL TRANSFORMER SWITCH
PLSC	PLS CONTROL SWITCH
PLSE	FREEZE STAT
FT	SMOKE DETECTOR
GFCD	GROUND FAULT CONVENIENCE OUTLET
GL	GROUND LUG
GND	GROUND
GV	GAS VALVE
HPC	HIGH PRESSURE CONTROL
IBM	INDOOR BLOWER MOTOR DIRECT DRIVE
IDM	INDUCED DRAFT MOTOR
IDR	INDUCED DRAFT RELAY
IFC	INTEGRATED FURNACE CONTROL
LAC	LOW AMBIENT COOLING CONTROL

DETAIL - A

NORMAL COOLING CAPACITY	MOTOR SPEED FROM FACTORY	AVAILABLE SPEEDS
5 TON	1ST STAGE COOL (TAP 1)	1ST STAGE COOL (TAP 1)
	2ND STAGE COOL (TAP 2)	LOW STAGE HEAT (TAP 2)
	100% (TAP 3)	MED STAGE HEAT (TAP 3)
	135% (TAP 4)	2ND STAGE COOL (TAP 4)
	2ND STAGE COOL (TAP 5)	HIGH STAGE HEAT (TAP 5)

DR. BY: MGR
APP. BY: DATE: 4-5-13
DWG. NO.: 90-23596-49
REV: 01

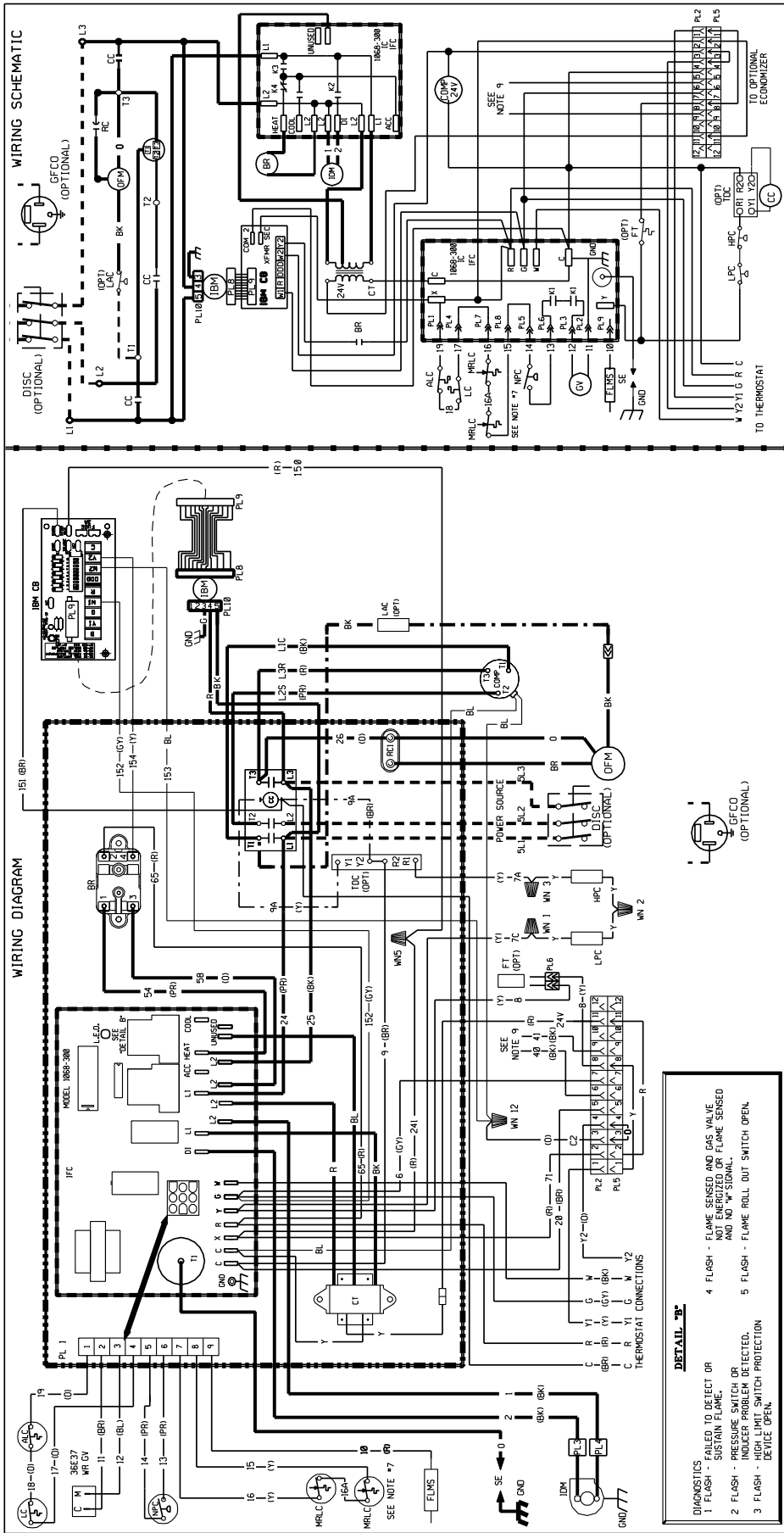

WIRING DIAGRAM

WIRING SCHEMATIC

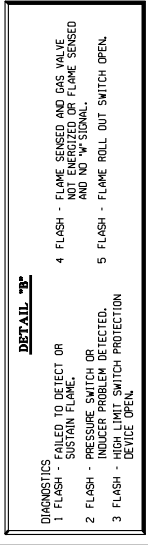

DETAIL-B
DIAGNOSTICS
1 FLASH - FAILED TO DETECT OR SUSPAIN FLAME.
2 FLASH - PRESSURE SWITCH OR SAFETY SWITCH PROTECTION
3 FLASH - HIGH WHITE SWITCH PROTECTION DEVICE OPEN.
4 FLASH - FLAME SENSED AND GAS VALVE OPENING.
5 FLASH - FLAME ROLL OUT SWITCH OPEN.

COMPONENT CODE

ALC	AUX. LIMIT CONTROL
BR	BLOWER RELAY
CC	COMPRESSOR CONTACTOR
COMP	COMPRESSOR
CONP	CONDENSER PUMP
FLMS	FLAME SENSOR
FT	FREZE STAT
GL	GROUND LUG
GN	GROUND
GV	GAS VALVE
HPC	HIGH PRESSURE CONTROL
IBM	INDOOR BLOWER MOTOR CV DRIVE
INDM	INDOOR BLOWER MOTOR CONTROL BOARD
INDR	INDUCED DRAFT MOTOR
IFC	INTERGRATED FURNACE CONTROL
LAC	LOW AMBIENT COOLING CONTROL
LC	LIMIT CONTROL
LPC	LOW PRESSURE CONTROL
MRLC	MANUAL RESET LIMIT CONTROL
NPC	NEGATIVE PRESSURE CONTROL
OPL	OUTDOOR FAN MOTOR
PLUG	PLUG
PC	RUN CAPACITOR
PE	POWER ELECTRODE
TDC	TIME DELAY CONTROL
WN	WIRE NUT

NOTES:

- CONNECTORS SUITABLE FOR USE WITH COPPER CONDUCTORS ONLY.
- COMPRESSOR MOTOR THERMALLY PROTECTED, ALL 3 PHASE MODELS ARE PROTECTED UNDER PRIMARY SINGLE PHASE CONDITIONS.
- CONTROL TRANSFORMER PRIMARY LEADS: RED-COMMON, BLUE-208V, BLACK-230V. TRANSFORMER FACTORY WIRE FOR 230 VOLTS. INTERCHANGE BLACK FOR BLUE LEADS FOR 208V OPERATION.
- SUPPLY CONTACTOR WIRE CORRECTLY FIELD WIRE TO FACTORY SUPPLY.
- LOW VOLTAGE CIRCUIT IS N.E.C. CLASS 2 WITH A CLASS 2 TRANSFORMER, 24V, 50/60 HZ SUPPLIED. 2 WITH A CLASS 2 TRANSFORMER.
- CONNECT FIELD WIRING IN GROUNDED RAIN TIGHT CONDUIT TO 60 HZ FUSED DISCONNECT.
- ONLY ONE MRLC IS NEEDED ON THE 90,000 INPUT UNIT.
- WIRE FROM PL 2, 17, 18, 6100 TO THE MIXED AIR SENSOR ON THE OPTIONAL ECONOMIZER.

WIRING INFORMATION

LINE VOLTAGE
-FACTORY STANDARD
-FACTORY OPTION
-FIELD INSTALLED
LOW VOLTAGE
-FACTORY STANDARD
-FACTORY OPTION
-FIELD INSTALLED
REPLACEMENT WIRE
-MUST BE THE SAME SIZE AND TYPE OF INSULATION AS ORIGINAL (105 C.MIN.)

WARNING:
-CABINET MUST BE PERMANENTLY GROUNDED AND CONFORM TO I.E.C., N.E.C., C.E.C., NATIONAL WIRING REGULATIONS, AND LOCAL CODES AS APPLICABLE.

WIRE COLOR CODE

BK	BLACK
BR	BROWN
BL	BLUE
G	GREEN
Y	YELLOW
O	ORANGE
PA	PURPLE
R	RED
W	WHITE
Y	YELLOW

ELECTRICAL WIRING DIAGRAM

208 / 230, 3 PHASE
CV DRIVE w/ ECON-MOTOR
2-STAGE

DR. BY: APP. BY: DATE: DWG. NO: 90-23596-50
MCR 6-24-13

REV: 01

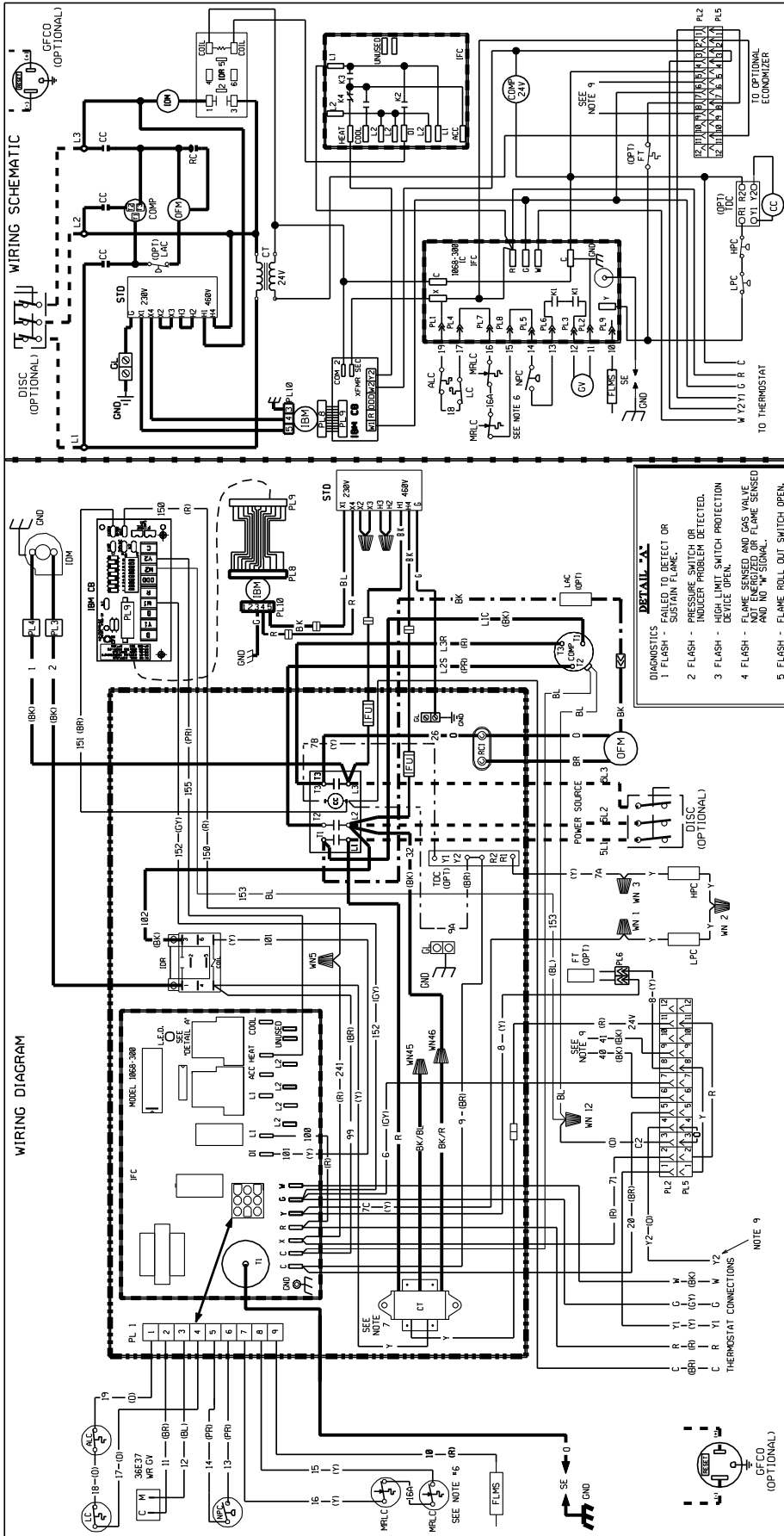

WIRING SCHEMATIC

WIRING DIAGRAM

WIRE COLOR CODE

BK	BLACK
BR	BROWN
BL	BLUE
G	GREEN
GY	GRAY
O	ORANGE
PR	PURPLE
R	RED
W	WHITE
Y	YELLOW

ELECTRICAL WIRING DIAGRAM
460V X-DRIVE MOTOR
DV DRIVE w/ EON BLOWER
2-STAGE

WIRING INFORMATION

LINE VOLTAGE
-FACTORY STANDARD
-FACTORY OPTION
-FIELD INSTALLED
LOW VOLTAGE
-FACTORY STANDARD
-FIELD INSTALLED
REPLACE WIRE
-MUST BE THE SAME SIZE AND TYPE OF INSULATION AS ORIGINAL (105 C.MIN.)
WARNING
-CABINET MUST BE PERMANENTLY GROUNDED AND CONFORM TO I.E.C., N.E.C., C.E.C., NATIONAL WIRING REGULATIONS, AND LOCAL CODES AS APPLICABLE.

NOTES:

- CONNECTORS SUITABLE FOR USE WITH COPPER CONDUCTORS ONLY.
- COMPRESSOR MOTOR THERMALLY PROTECTED. ALL 3 PHASE MODELS.
- THE FACTORY STANDARD WIRING IS BASED ON THE FOLLOWING CONDITIONS:
3. CONTROL CIRCUIT WIRE SHALL BE CONDUCTED WIRE TO FACTORY SUPPLIED CONTACTOR IN ELECTRICAL BOX.
- LOW VOLTAGE CIRCUIT IS N.E.C. CLASS 2 WITH A CLASS 2 TRANSFORMER 24V/56/60 HZ SUPPLIED.
- CONNECT FELD WIRING IN GROUNDED RAIN TIGHT CONDUIT TO 60 HZ FUSED DISCONNECT.
- ONLY ONE MRLC IS NEEDED ON THE 88-0000 INPUT UNIT.
- CONTROL TRANSFORMER PRIMARY LEADS: BLUE-COMMON; BK/RED-460V, 60 HZ / 380V, 50 HZ; RED-575V, 60 HZ / 415V, 50 HZ.
- WIRES FROM PL2 (7 & 8) GO TO THE MIXED AIR SENSOR ON THE OPTIONAL ECONOMIZER.

COMPONENT CODE

ALC	AUX LIMIT CONTROL
BC	BLOWER CONTACTOR
CC	COMPRESSOR CONTACTOR
CCOMP	COMPRESSOR
CT	CONTROL TRANSFORMER
DISC	DISCONNECT SWITCH
FLMS	FLAME SENSOR
FT	FREESTAT
FUSE	FUSE
GFCO	GROUND FAULT CIRCUIT INTERRUPTER
GN	GROUND LUG
GV	GAS VALVE
HPC	HIGH PRESSURE CONTROL
IDM	INDOOR BLOWER MOTOR DIRECT DRIVE
IBM	INDOOR BLOWER MOTOR
IDR	INDUCED DRAFT RELAY
IFC	INTEGRATED FURNACE CONTROL
LAC	LOW AMBIENT COOLING CONTROL
LC	LOW LIMIT CONTROL
LFC	LOW PRESSURE CONTROL
MRLC	MANUAL RESET LIMIT CONTROL
NPC	NEGATIVE PRESSURE CONTROL
OPM	OUTDOOR FAN MOTOR
PL	PLUG
RC	RUN CAPACITOR
SD	SMOKE DETECTOR
ST	STEPDOWN TRANSFORMER
TDC	TIME DELAY CONTROL
WN	WIRE NUT

DR: BY DATE DWG. NO.
MGR APP. BY 6-25-13 90-23596-51
REV 01

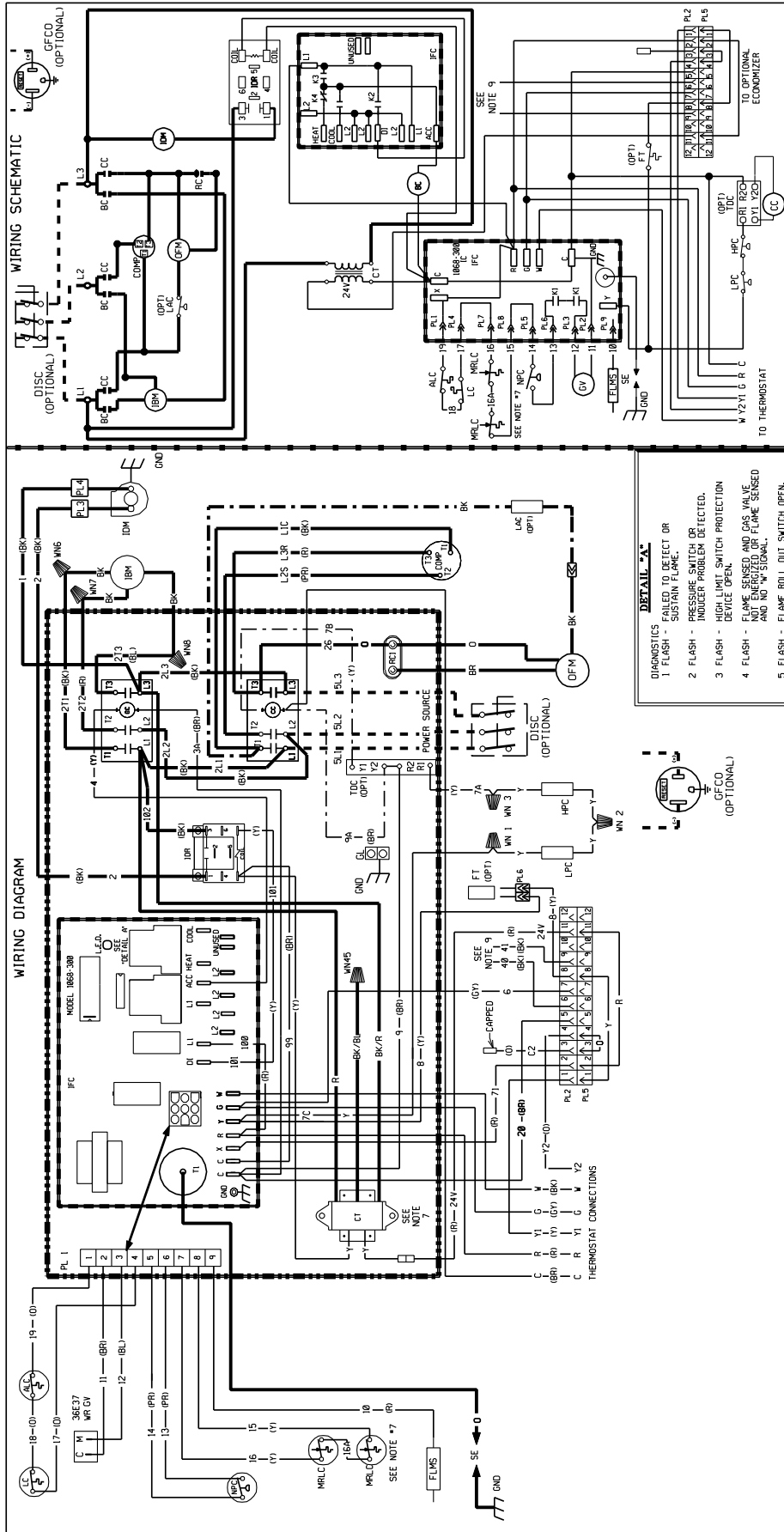

WIRING SCHEMATIC

DISC (OPTIONAL) GFCO (OPTIONAL)

WIRING SCHEMATIC

TO THERMOSTAT

TO OPTIONAL ECONOMIZER

WIRE COLOR CODE

BK	BLACK
BR	BROWN
BL	BLUE
G	GREEN
GY	GRAY
OR	ORANGE
PR	PURPLE
R	RED
W	WHITE
Y	YELLOW

ELECTRICAL WIRING DIAGRAM

460 3 PHASE, 60 HZ
BELT DRIVE

DR. BY: MGR
APP. BY: DATE 2-11-13
DWG. NO. 90-23596-41
REV 01

WIRING INFORMATION

LINE VOLTAGE
-FACTORY STANDARD
-FACTORY OPTION
-FIELD INSTALLED
LOW VOLTAGE
-FACTORY STANDARD
-FACTORY OPTION
-FIELD INSTALLED
REPLACEMENT WIRE
-MUST BE THE SAME SIZE AND TYPE OF INSULATION AS ORIGINAL (105 C.MIN.)
WARNING
-CABINET MUST BE PERMANENTLY GROUNDED AND CONFORM TO I.E.C., N.E.C., C.E.C., NATIONAL WIRING REGULATIONS, AND LOCAL CODES AS APPLICABLE.

NOTES:

- CONNECTORS SUITABLE FOR USE WITH COPPER CONDUCTORS ONLY. COMPRESSOR MOTOR THERMALLY PROTECTED. ALL 3 PHASE MODELS ARE PROTECTED UNDER PRIMARY SINGLE PHASE CONDITIONS.
- CONTRACTOR FACTORY WIRE CONNECT BOX TO FACTORY
- CONTRACTOR FACTORY WIRE CONNECT BOX TO FACTORY
- CONTRACTOR FACTORY WIRE CONNECT BOX TO FACTORY
- CONTRACTOR FACTORY WIRE CONNECT BOX TO FACTORY
- CONTRACTOR FACTORY WIRE CONNECT BOX TO FACTORY
- CONTRACTOR FACTORY WIRE CONNECT BOX TO FACTORY
- CONTRACTOR FACTORY WIRE CONNECT BOX TO FACTORY
- CONTRACTOR FACTORY WIRE CONNECT BOX TO FACTORY
- CONTRACTOR FACTORY WIRE CONNECT BOX TO FACTORY

COMPONENT CODE

ALC	AUX LIMIT CONTROL
BC	BLOWER CONTACTOR
CC	COMPRESSOR CONTACTOR
COMP	COMPRESSOR
DISC	DISCONNECT SWITCH
FLMS	FLAME SENSOR
FT	FREEZE STAT
GFCO	GROUND FAULT CONVENIENCE OUTLET
GV	GAS VALVE
GR	GROUND LUG
HPC	HIGH PRESSURE CONTROL
IBM	INDOOR BLOWER MOTOR
IDR	INDUCED DRAFT MOTOR
IFC	INTERGRADED FURNACE CONTROL
LAC	LOW AMBIENT COOLING CONTROL
LPC	LOW PRESSURE CONTROL
MRLC	MANUAL RESET LIMIT CONTROL
NPC	NEGATIVE PRESSURE CONTROL
ODFM	OUTDOOR FAN MOTOR
PL	PLUG
PT	POWER TRANSFORMER
RC	RUN CAPACITOR
SD	SHOCK DETECTOR
TC	TEMPERATURE CONTROL
WV	WIRE NUT
WV	WIRE NUT
IDR	INDUCED DRAFT RELAY
IBM	INDOOR BLOWER MOTOR
IFC	INTERGRADED FURNACE CONTROL
LAC	LOW AMBIENT COOLING CONTROL

DETAIL 2A

DIAGNOSTICS FAILED TO DETECT OR
1 FLASH - SUSTAIN FLAME.
2 FLASH - PRESSURE SWITCH OR DETECTED.
3 FLASH - HIGH LIMIT SWITCH PROTECTION DEVICE OPEN.
4 FLASH - FLAME SENSED AND GAS VALVE AND NO SIGNAL.
5 FLASH - FLAME ROLL OUT SWITCH OPEN.

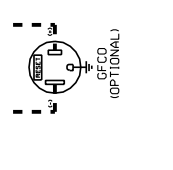

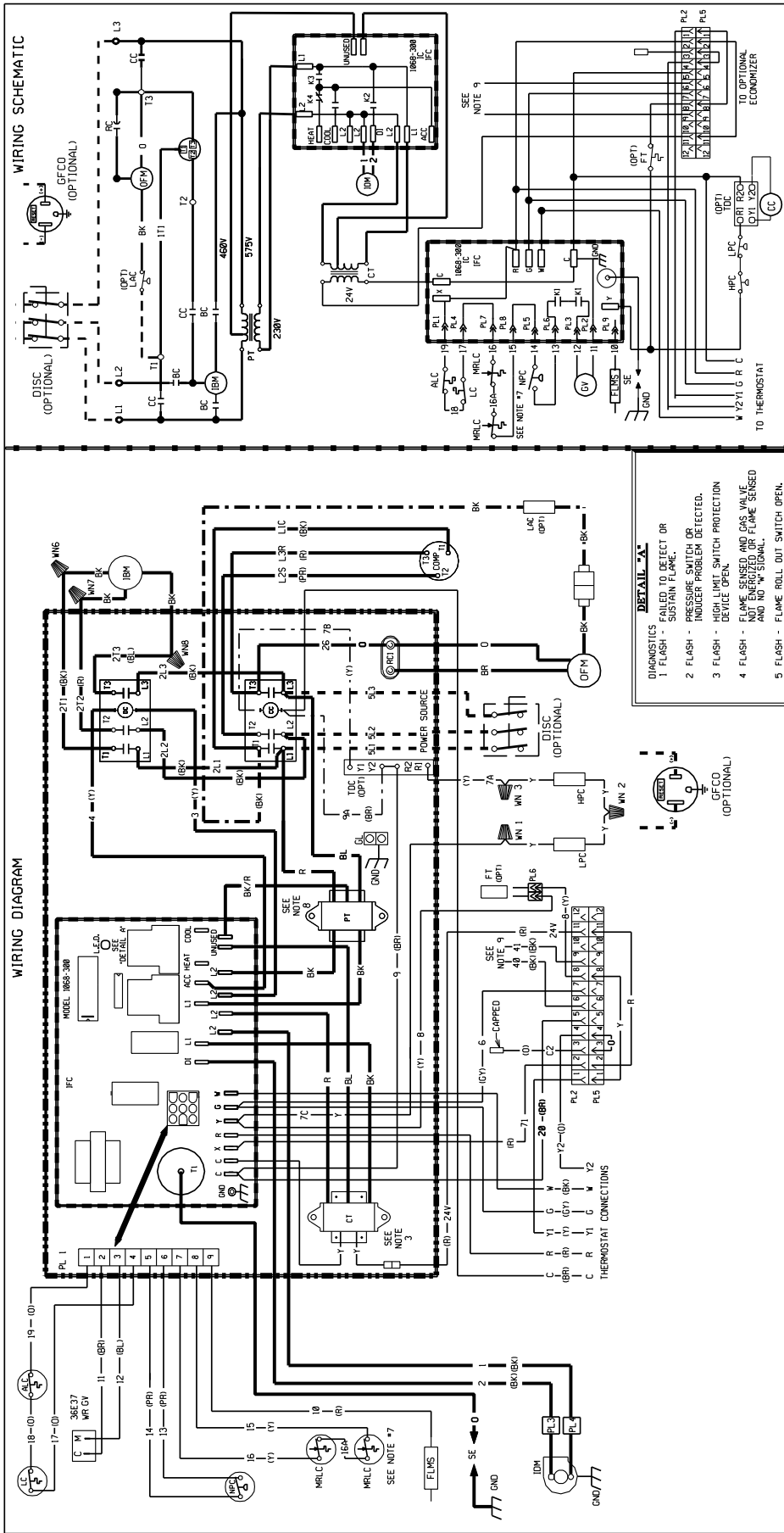

WIRING DIAGRAM

WIRING SCHEMATIC

COMPONENT CODE

ALC	AUX. LIMIT CONTROL
BC	BLOWER CONTACTOR
CC	COMPRESSOR CONTACTOR
CC	COMPRESSOR
CT	CONTROL TRANSFORMER
CT	DISCONNECT SWITCH
DISC	DISCONNECT SWITCH
FT	FREEZE START
GFCO	GROUND FAULT CONVENIENCE OUTLET
GL	GROUND LUG
GND	GROUND
GV	GAS VALVE
HPC	HIGH PRESSURE CONTROL
IDM	INDOOR BLOWER MOTOR DIRECT DRIVE
IFC	INDUCED DRAFT MOTOR
IFC	INTERGRATED FURNACE CONTROL
LAC	LOW AMBIENT COOLING CONTROL
LC	LIMIT CONTROL

WIRE COLOR CODE

BK	BLACK	0	ORANGE
BR	BROWN	PR	PURPLE
BL	BLUE	R	RED
G	GREEN	W	WHITE
CY	GRAY	Y	YELLOW

NOTES:

- CONNECTORS SUITABLE FOR USE WITH COPPER CONDUCTORS ONLY.
- COMPRESSOR MOTOR THERMALLY PROTECTED. ALL 3 PHASE MODELS ARE PROTECTED UNDER PRIMARY SINGLE PHASE CONDITIONS.
- CONTROL TRANSFORMER PRIMARY LEADS: RED-COMMON, BLUE-208V, BLACK-230V. TRANSFORMER FACTORY WIRE FOR 230 VOLTS. INTERCHANGE BLACK FOR BLUE LEADS FOR 208V OPERATION.
- CONTACTOR FACTORY WIRE TO FACTORY SUPPLIED CONTACTOR IN ELECTRICAL BOX.
- LOW VOLTAGE CIRCUIT IS N.E.C. CLASS 2 WITH A CLASS 2 TRANSFORMER, 24V/50/60 HZ SUPPLIED.
- CONNECT FIELD WIRING IN GROUNDING RAIN TIGHT CONDUIT TO 60 HZ FUSED DISCONNECT.
- ONLY ONE MRLC IS NEEDED ON THE 06,000 INPUT UNIT.
- POWER TRANSFORMER PRIMARY LEADS: BLUE-COMMON, RED-575V, 60 HZ. / 415V, 50 HZ.
- WIRES FROM PL2 16 & 9: GO TO THE MIXED AIR SENSOR ON THE OPTIONAL ECONOMIZER.
10. 12 IS USED ONLY FOR THE OPTIONAL ECONOMIZER.

WIRING INFORMATION

LINE VOLTAGE
-FACTORY STANDARD
-FACTORY OPTION
-FIELD INSTALLED
-FACTORY STANDARD
-FACTORY OPTION
-FIELD INSTALLED
REPLACEMENT WIRE
-MUST BE THE SAME SIZE AND TYPE OF INSULATION AS ORIGINAL (105 C. MIN.)
WARNING:
-CABINET MUST BE PERMANENTLY GROUNDED AND CONFORM TO I.E.C., N.E.C., C.E.C., NATIONAL WIRING REGULATIONS, AND LOCAL CODES AS APPLICABLE.

DIAGNOSTICS

- FLASH - FAILED TO DETECT OR SUSTAIN FLAME.
- FLASH - PRESSURE SWITCH OR INDUCER PROBLEM DETECTED.
- FLASH - HIGH LIMIT SWITCH PROTECTION DEVICE OPEN.
- FLASH - FLAME SENSED AND GAS VALVE NOT ENERGIZED OR FLAME SENSED AND NO "W" SIGNAL.
- FLASH - FLAME ROLL OUT SWITCH OPEN.

DETAIL - "A"

DISCONNECTS
1 FLASH - FAILED TO DETECT OR SUSTAIN FLAME.
2 FLASH - PRESSURE SWITCH OR INDUCER PROBLEM DETECTED.
3 FLASH - HIGH LIMIT SWITCH PROTECTION DEVICE OPEN.
4 FLASH - FLAME SENSED AND GAS VALVE NOT ENERGIZED OR FLAME SENSED AND NO "W" SIGNAL.
5 FLASH - FLAME ROLL OUT SWITCH OPEN.

WIRE COLOR CODE

BK	BLACK	0	ORANGE
BR	BROWN	PR	PURPLE
BL	BLUE	R	RED
G	GREEN	W	WHITE
CY	GRAY	Y	YELLOW

ELECTRICAL WIRING DIAGRAM

575, 3 PHASE, 60 HZ
BELT DRIVE

DR. BY: MGR APP. BY: DATE: 2-11-13 DWG. NO: 90-23596-45 REV: 01

BEFORE PURCHASING THIS APPLIANCE, READ IMPORTANT ENERGY COST AND EFFICIENCY INFORMATION AVAILABLE FROM YOUR RETAILER.

GENERAL TERMS OF LIMITED WARRANTY*

Rheem will furnish a replacement for any part of this product which fails in normal use and service within the applicable periods stated, in accordance with the terms of the limited warranty.

***For complete details of the Limited and Conditional Warranties, including applicable terms and conditions, contact your local contractor or the Manufacturer for a copy of the product warranty certificate.**

Compressor

3-Phase, Commercial ApplicationsFive (5) Years

Parts

3-Phase, Commercial ApplicationsOne (1) Year

Factory Standard Heat Exchanger

3-Phase, Commercial ApplicationsTen (10) Years

Stainless Steel Heat Exchanger

3-Phase, Commercial ApplicationsTwenty (20) Years



The new degree of comfort.™

In keeping with its policy of continuous progress and product improvement, Rheem reserves the right to make changes without notice.

Rheem Heating, Cooling & Water Heating • P.O. Box 17010
Fort Smith, Arkansas 72917 • www.rheem.com

Rheem Canada Ltd./Ltée • 125 Edgeware Road, Unit 1
Brampton, Ontario • L6Y 0P5



INTEGRATED AIR & WATER

PRINTED IN U.S.A 11/13 QG FORM NO. R11-866 REV. 1