



RKKL-B

Parts List
27-September-2014



*This parts list is current as of the above revision date.
See <http://www.rheempartslists.net/92-42800-RKKL-B.pdf> for the current revision.*

Package Gas-Electric - Commercial

Table of Contents

Model Explanation.....	Page 3
Parts Numbers	
Panels - Miscellaneous (Granite-Steel Gray) 072	Page 4
Panels - Miscellaneous (Neutra Green) 072	Page 5
Panels - Miscellaneous (Granite-Steel Gray) 090-151 (1)	Page 6
Panels - Miscellaneous (Granite-Steel Gray) 090-151 (2)	Page 7
Panels - Miscellaneous (Neutra Green) 090-151 (1)	Page 8
Panels - Miscellaneous (Neutra Green) 090-151 (2)	Page 9
Panels - Miscellaneous (Granite-Steel Gray) 180-240 (1)	Page 10
Panels - Miscellaneous (Granite-Steel Gray) 180-240 (2)	Page 11
Panels - Miscellaneous (Neutra Green) 180-240 (1)	Page 12
Panels - Miscellaneous (Neutra Green) 180-240 (2)	Page 13
Electrical Group 072	Page 14
Fan Group 072	Page 14
Electrical Group 090-151 (1)	Page 15
Electrical Group 090-151 (2)	Page 16
Electrical Group 180-240 (1)	Page 17
Electrical Group 180-240 (2)	Page 18
Fan Group 090-151	Page 19
Fan Group 180-240	Page 20
Blower Group 072 - Belt Drive 072	Page 21
Blower Group 090-151	Page 22
Blower Group 180-240	Page 23
Coil Parts 072	Page 24
Compressor Group 072	Page 24
Coil Parts 090-120	Page 25
Coil Parts 151	Page 26
Coil Parts 180-240	Page 27
Compressor Group 090-120	Page 28
Compressor Group 151	Page 29
Compressor Group 180-240	Page 30
Heat Exchanger-Burner Group 072	Page 31
Heat Exchanger-Burner Group 090-120	Page 32
Heat Exchanger-Burner Group 151	Page 33
Heat Exchanger-Burner Group 180	Page 34
Heat Exchanger-Burner Group 240	Page 35
Gas Controls	Page 36
Accessories 072-151	Page 37
Accessories 180-240	Page 38
Orifice Selection Chart	Page 39

Drawings/Photographs

Exploded View 072	Page 40
Control Box 072	Page 41
Blower Assembly - Belt Drive 072	Page 42
Blower Motor Mount Assembly - Belt Drive 072	Page 43
Coil Group Cut-away View 072	Page 44
Evaporator Coil - Filter Parts 072	Page 44
Compressor - Refrigeration Group 072	Page 45
Heat Exchanger Assembly 072	Page 45
One Piece Burner Assembly 072	Page 46
Exploded View 090-151	Page 47
Control Box 090-151	Page 48
Low Voltage Shields 090-151	Page 49
Exterior - Front 090-151	Page 50
Exterior - Back 090-151	Page 50
Filter-Coil Assembly 090-151	Page 51
Condenser Coil Assembly 090-151	Page 51
Heat Exchanger Assembly 090-151	Page 52
Front Panel Brackets 090-151	Page 52
Filter Frame Assembly 090-151	Page 53
Blower Assembly 090-151	Page 53
Exterior - Front 180	Page 54
Exterior - Back 180	Page 54
Exterior - Front 240	Page 55
Exterior - Back 240	Page 55
Front Panel Brackets 180	Page 56
Front Panel Brackets 240	Page 56
Heat Compartment 180-240	Page 57
Condenser Bulkhead 180-240	Page 57
Base Pan Assembly 180-240	Page 58
Base Rail Assembly 180-240	Page 58
Control Box 180-240	Page 59
Condenser Bulkhead 180-240	Page 57
Condenser Coil 180	Page 60
Condenser Coil Airstop - 240	Page 61
Condenser Coil - 240	Page 62
Interior - Front 180	Page 63
Interior - Front 240	Page 63
Burner Assembly 180-240	Page 64
Heat Exchanger Assembly 180 - 240	Page 64
Pressure Switch - Mounting 180 - 240	Page 65
Filter Frame Assembly 180-240	Page 66
Blower Assembly 180-240	Page 67

MODEL NUMBER EXPLANATION

R	K	K	L	-	B	0	7	2	C	L	1	0	E	X	X	A
1	2	3	4		5		6		7	8		9	10		11	12

- | | |
|--|---|
| <p>1 TRADENAME</p> <p>2 K = ROOFTOP - COMMERCIAL</p> <p>3 EFFICIENCY DESIGNATION</p> <p>4 DESIGN SERIES
(R-410A)</p> <p>5 TECHNICAL VARIATIONS</p> <p>6 COOLING CAPACITY (BTU/HR)
072 = 72,000
090 = 90,000
120 = 120,000
151 = 150,000
180 = 180,000
240 = 240,000</p> <p>7 ELECTRIC DESIGNATION
J = 208-230/1/60
C = 208-230/3/60
D = 460/3/50
Y = 575/3/60</p> | <p>8 DRIVE PACKAGE
K = Direct Drive
L = Belt Drive
M = Belt Drive - High Static</p> <p>9 HEAT CAPACITY (MBH)
08 = 80,000
10 = 100,000
12 = 120,000
13 = 135,000
15 = 150,000
22 = 220,000
25 = 250,000
35 = 350,000
40 = 400,000</p> <p>10 IGNITION SYSTEM
E = Electric Ignition
X = Electric Ignition, NOx</p> <p>11 FACTORY INSTALLED OPTIONS</p> <p>12 ECONOMIZER OPTION
A = No Economizer
B = Single Enthalpy Economizer with Barometric Relief
C = Single Enthalpy Economizer with Barometric Relief and Smoke Detector</p> |
|--|---|

SERIAL NUMBER EXPLANATION

1	X	A	1	2	3	4	A	A	A	A	F	26	10	00001
1	2		3			4	5	6	7	8	9	10	11	

- | | |
|--|--|
| <p>1 GAS CODE</p> <p>2 BLOWER CONTROL BOARD</p> <p>3 COMPRESSOR IDENTIFICATION NUMBER</p> <p>4 IGNITION DEVICE</p> <p>5 INDUCER BLOWER</p> <p>6 HEAT EXCHANGER</p> | <p>7 TECHNOLOGY VARIATIONS</p> <p>8 PRODUCTION LOCATION
F = Fort Smith, AR</p> <p>9 WEEK</p> <p>10 YEAR</p> <p>11 PRODUCTION NUMBER</p> |
|--|--|

No.	Notes	MODEL TECHNICAL VARIATION COOLING CAPACITY	RKKL- B 072
PANELS, MISCELLANEOUS PARTS (Granite Steel Gray - After F4411)			
1		Base Rail - Side (2)	AE-58900-02
2		Base Rail - Condenser End	AE-58901-01
3		Base Rail - Evaporator End	AE-58902-01
4		Outdoor Coil Base Pan	AS-59051-01H
5		Indoor Coil Base Pan	AS-58910-06
7		Condenser Bulkhead (Does not include Limit Baffle or Tube Support Angles)	AS-103276-01
		Limit Baffle - Attached To Condenser Bulkhead (10E Heat Capacity)	AE-58913-02
		Limit Baffle - Attached To Condenser Bulkhead (13E Heat Capacity)	AE-58913-01
		Tube Support Angle - Attached To The Condenser. Bulkhead	AE-59139-01
8		Blower Bulkhead (Does not include Tube Support Angle, Blower Extension, or Insulation Retainer)	AS-103385-01
		Tube Support Angle (Small piece attached to the Blower Bulkhead)	AE-59139-02
9		Blower Extension - Front	AE-58928-01
10		Blower Extension - Back	AE-58928-02
		Insulation Retainer	AE-59059-01
11		Wire Chase Insulation Assembly	AS-103291-01
12		Corner Post (2)	AE-58965-01
14		Louvered Panel	See Accessories
15		Louvered Panel	See Accessories
16		Louvered Panel	See Accessories
17		Supply/Return Panels (2)	AS-58992-01H
18		Rear Panel (Includes Insulation, Filler Panel, and Stripping)	AS-58976-02H
19		Filler Panel - Return Air	AS-58974-02H
		Filler Panel Stripping	AE-58897-10
20		Blower/Filter Access Panels (2)	AS-58990-01H
21		Post - Left End	AS-58973-01H
22		Front Panel	AS-59132-05H
23		Grommet	56-22114-06
24		Heating Compartment Access Panel	AS-58988-02H
25		Flue Hood	AS-58882-01
		Flue Hood Gasket	68-23680-03
		Mounting Panel - External Disconnect	AE-59133-01
26		Control Box Access Panel	AS-103284-01H
28		Front Post	AS-103288-01H
29		Indoor Coil Top Panel Assembly	AS-58979-02H
30		Condenser Top Panel Assembly	AS-58981-01H
32		Wire Grille	95-101660-01
34		Control Box (w/o components)	AS-103281-01

No.	Notes	MODEL TECHNICAL VARIATION COOLING CAPACITY	RKKL- B 072
PANELS, MISCELLANEOUS PARTS (Neutra Green - Before F4411)			
1		Base Rail - Side (2)	AE-58900-02
2		Base Rail - Condenser End	AE-58901-01
3		Base Rail - Evaporator End	AE-58902-01
4		Outdoor Coil Base Pan	AS-59051-01A
5		Indoor Coil Base Pan	AS-58910-06
7		Condenser Bulkhead (Does not include Limit Baffle or Tube Support Angles)	AS-103276-01
		Limit Baffle - Attached To Condenser Bulkhead (08E, 08X, 10E, 10x, 12E, 12X, 13X Heat Capacity)	AE-58913-02
		Limit Baffle - Attached To Condenser Bulkhead (13E Heat Capacity)	AE-58913-01
		Tube Support Angle - Attached To The Condenser. Bulkhead	AE-59139-01
8		Blower Bulkhead (Does not include Tube Support Angle, Blower Extension, or Insulation Retainer)	AS-103385-01
		Tube Support Angle (Small piece attached to the Blower Bulkhead)	AE-59139-02
9		Blower Extension - Front	AE-58928-01
10		Blower Extension - Back	AE-58928-02
		Insulation Retainer	AE-59059-01
11		Wire Chase Insulation Assembly	AS-103291-01
12		Corner Post (2)	AE-58965-01
14		Louvered Panel	See Accessories
15		Louvered Panel	See Accessories
16		Louvered Panel	See Accessories
17		Supply/Return Panels (2)	AS-58992-01A
18		Rear Panel (Includes Insulation, Filler Panel, and Stripping)	AS-58976-02A
19		Filler Panel - Return Air	AS-58974-02A
		Filler Panel Stripping	AE-58897-10
20		Blower/Filter Access Panels (2)	AS-58990-01A
21		Post - Left End	AS-58973-01A
22		Front Panel	AS-59132-05A
23		Grommet	56-22114-06
24		Heating Compartment Access Panel	AS-58988-02A
25		Flue Hood	AS-58882-01
		Flue Hood Gasket	68-23680-03
		Mounting Panel - External Disconnect	AE-59133-01
26		Control Box Access Panel	AS-103284-01A
28		Front Post	AS-103288-01A
29		Indoor Coil Top Panel Assembly	AS-58979-02A
30		Condenser Top Panel Assembly	AS-58981-01A
32		Wire Grille	95-101660-01
34		Control Box (w/o components)	AS-103281-01

No.	Notes	MODEL TECHNICAL VARIATION COOLING CAPACITY	RKKL- B 090	RKKL- B 120	RKKL- B 151
PANELS - RAILS, BASE PANS, INSIDE CABINET (Granite/Steel Gray - After F4411)					
BASE RAILS:					
A		Base Rail - Front	AE-90575-15	AE-90575-15	AE-90575-15
B		Base Rail - Right	AE-90576-03	AE-90576-03	AE-90576-03
C		Base Rail - Rear	AE-90575-04	AE-90575-04	AE-90575-04
D		Base Rail - Left	AE-90576-04	AE-90576-04	AE-90576-04
BASE PANS:					
E		Outdoor Coil Base Pan Assembly	AS-90577-14H	AS-90577-15H	AS-90577-14H
F		Indoor Coil Base Pan Assembly	AS-90577-12	AS-90577-12	AS-90577-12
INSIDE CABINET:					
G		Entry Plate	AE-90614-01	AE-90614-01	AE-90614-01
H		Entry Plate	AE-90614-01	AE-90614-01	AE-90614-01
J		Heat Compartment Side	AE-90598-07	AE-90598-07	AE-90598-07
K		Blower Deck	AS-90592-10	AS-90592-10	AS-90592-10
L		Wireway	AE-90718-05	AE-90718-05	AE-90718-05
M		Condenser Bulkhead	AS-90609-30	AS-90609-25	AS-90609-19

No.	Notes	MODEL TECHNICAL VARIATION COOLING CAPACITY	RKKL- B 090	RKKL- B 120	RKKL- B 151
PANELS - FRONT (Granite/Steel Gray - After F4411)					
1		Control Box Door Assembly - w/Hinges, Gasket, Insulation	AS-102872-13H	AS-102872-13H	AS-102872-13H
2a		Bracket - Top Panel (Left)	AS-102859-16H	AS-102859-16H	AS-102859-16H
2b		Bracket - Top Panel (Center)	AS-102859-15H	AS-102859-15H	AS-102859-15H
2c		Post - Blower Section	AS-102682-12H	AS-102682-12H	AS-102682-12H
3a		Bracket - Bottom Panel (Left)	AS-102859-17H	AS-102859-17H	AS-102859-17H
3b		Bracket - Blower/Heater Compartment	AS-102859-14H	AS-102859-14H	AS-102859-14H
3c		Bracket - Bottom Panel (Right)	AS-102859-13H	AS-102859-13H	AS-102859-13H
4		Post Assembly - Indoor Coil Section	AS-90620-18H	AS-90620-18H	AS-90620-24H
5		Control Box Cover	AE-90713-02	AE-90713-02	AE-90713-02
6		Control Mounting Plate	AE-90712-06	AE-90712-06	AE-90712-06
7a		Low Voltage Shield (Before F3512) - Upper Straight	AE-90742-08	AE-90742-08	AE-90742-08
7a		Low Voltage Shield (After F3512) - Upper Angled	AE-90742-12	AE-90742-12	AE-90742-12
7b		Low Voltage Shield (Before F3512) - Lower	AE-90742-03	AE-90742-03	AE-90742-03
7b		Low Voltage Shield (After F3512) - Lower	AE-90742-11	AE-90742-11	AE-90742-11
7c		Low Voltage Shield - Middle Strip	AE-90742-09	AE-90742-09	AE-90742-09
8		Control Box Back Insulation Assembly	AS-90601-06	AS-90601-06	AS-90601-06
9		Mounting Bracket	AE-90779-02	AE-90779-02	AE-90779-02
		Outlet Flue Hood	AS-102966-01	AS-102966-01	AS-102966-01
	5	Inlet Flue Hood (2) - See Note 5	AE-90745-04	AE-90745-04	AE-90745-04
12	5	Gas Heat Access Panel Assembly - w/Hinges, Gasket, Insulation - See Note 5	AS-102872-19H	AS-102872-19H	AS-102872-19H
13		Gas Pipe Support Plate	AS-90774-10H	AS-90774-10H	AS-90774-10H
14		Blower Access Panel Assembly - w/Hinges, Gasket, Insulation	AS-102872-15H	AS-102872-15H	AS-102872-15H
15		High Pressure Guard (2)	N/A	N/A	N/A
16		Heat Exchanger Mounting Frame Assembly	AS-90754-01	AS-90754-01	AS-90754-01
17		Condenser Coil Access Panel - Front	AS-90631-10H	AS-90631-11H	AS-90631-11H
18		Front Corner Post	AS-90701-05H	AS-90701-05H	AS-90701-05H

No.	Notes	MODEL TECHNICAL VARIATION COOLING CAPACITY	RKKL- B 090	RKKL- B 120	RKKL- B 151
PANELS - RIGHT, REAR AND LEFT SIDES (Granite/Steel Gray - After F4411)					
RIGHT:					
19		Air Stop	N/A	N/A	N/A
20		Louver Panel Assembly	AS-90789-03H	AS-90789-03H	AS-90789-03H
REAR:					
21		Rear Corner Post	AS-90702-04H	AS-90702-04H	AS-90702-04H
22		Condenser Coil Access Panel-Rear	AS-90631-03H	AS-90631-12H	AS-90631-12H
23		Rear Panel	AS-90618-02H	AS-90618-02H	AS-90618-02H
24		Supply Cover	AS-90626-02H	AS-90626-02H	AS-90626-02H
25		Return Cover	AS-90628-02H	AS-90628-02H	AS-90628-02H
LEFT:					
26		Upper Left Panel	AS-90624-03H	AS-90624-03H	AS-90624-03H
27		Lower Left Panel	AS-90624-04H	AS-90624-04H	AS-90624-04H
28		Left Corner Panel	AS-90755-10H	AS-90755-10H	AS-90755-10H
29		Plate - Receptacle	AS-90756-02H	AS-90756-02H	AS-90756-02H
30		Plate - Disconnect	AS-90756-03H	AS-90756-03H	AS-90756-03H
31		Button Plug (2)	45-22980-06	45-22980-06	45-22980-06
32		Button Plug	45-22980-05	45-22980-05	45-22980-05
TOP:					
33		Top Panel Assembly	AS-90616-06H	AS-90616-06H	AS-90616-06H
34		Condenser Top Panel	AS-102872-25H	AS-102872-21H	AS-102872-21H
35		Venturi	AS-90632-03H (1)	AS-90632-03H (2)	AS-90632-03H (2)
36		Wire Grille	95-100906-09 (1)	95-100906-09 (2)	95-100906-09 (2)
43		Drain Pan - Removable	See Coil Group		

No.	Notes	MODEL TECHNICAL VARIATION COOLING CAPACITY	RKKL- B 090	RKKL- B 120	RKKL- B 151
PANELS - RAILS, BASE PANS, INSIDE CABINET (Neutra Green, Before F4411)					
BASE RAILS:					
A		Base Rail - Front	AE-90575-15	AE-90575-15	AE-90575-15
B		Base Rail - Right	AE-90576-03	AE-90576-03	AE-90576-03
C		Base Rail - Rear	AE-90575-04	AE-90575-04	AE-90575-04
D		Base Rail - Left	AE-90576-04	AE-90576-04	AE-90576-04
BASE PANS:					
E		Outdoor Coil Base Pan Assembly	AS-90577-14A	AS-90577-15A	AS-90577-14A
F		Indoor Coil Base Pan Assembly	AS-90577-12	AS-90577-12	AS-90577-12
INSIDE CABINET:					
G		Entry Plate	AE-90614-01	AE-90614-01	AE-90614-01
H		Entry Plate	AE-90614-01	AE-90614-01	AE-90614-01
J		Heat Compartment Side	AE-90598-07	AE-90598-07	AE-90598-07
K		Blower Deck	AS-90592-10	AS-90592-10	AS-90592-10
L		Wireway	AE-90718-05	AE-90718-05	AE-90718-05
M		Condenser Bulkhead	AS-90609-30	AS-90609-25	AS-90609-19

No.	Notes	MODEL TECHNICAL VARIATION COOLING CAPACITY	RKKL- B 090	RKKL- B 120	RKKL- B 151
PANELS - FRONT (Neutra Green, Before F4411)					
1		Control Box Door Assembly - w/Hinges, Gasket, Insulation	AS-102872-13A	AS-102872-13A	AS-102872-13A
2a		Bracket - Top Panel (Left)	AS-102859-16A	AS-102859-16A	AS-102859-16A
2b		Bracket - Top Panel (Center)	AS-102859-15A	AS-102859-15A	AS-102859-15A
2c		Post - Blower Section	AS-102682-12A	AS-102682-12A	AS-102682-12A
3a		Bracket - Bottom Panel (Left)	AS-102859-17A	AS-102859-17A	AS-102859-17A
3b		Bracket - Blower/Heater Compartment	AS-102859-14A	AS-102859-14A	AS-102859-14A
3c		Bracket - Bottom Panel (Right)	AS-102859-13A	AS-102859-13A	AS-102859-13A
4		Post Assembly - Indoor Coil Section	AS-90620-18A	AS-90620-18A	AS-90620-17A
5		Control Box Cover	AE-90713-02	AE-90713-02	AE-90713-02
6		Control Mounting Plate	AE-90712-06	AE-90712-06	AE-90712-06
7a		Low Voltage Shield - Upper Straight	AE-90742-08	AE-90742-08	AE-90742-08
7b		Low Voltage Shield - Lower	AE-90742-03	AE-90742-03	AE-90742-03
7c		Low Voltage Shield - Middle Strip	AE-90742-09	AE-90742-09	AE-90742-09
8		Control Box Back Insulation Assembly	AS-90601-06	AS-90601-06	AS-90601-06
9		Mounting Bracket	AE-90779-02	AE-90779-02	AE-90779-02
		Outlet Flue Hood	AS-102966-01	AS-102966-01	AS-102966-01
	5	Inlet Flue Hood (2) - See Note 5	AE-90745-04	AE-90745-04	AE-90745-04
12	5	Gas Heat Access Panel Assembly - w/Hinges, Gasket, Insulation - See Note 5	AS-102872-19A	AS-102872-19A	AS-102872-19A
13		Gas Pipe Support Plate	AS-90774-10A	AS-90774-10A	AS-90774-10A
14		Blower Access Panel Assembly - w/Hinges, Gasket, Insulation	AS-102872-15A	AS-102872-15A	AS-102872-15A
15		High Pressure Guard (2)	N/A	N/A	N/A
16		Heat Exchanger Mounting Frame Assembly	AS-90754-01	AS-90754-01	AS-90754-01
17		Condenser Coil Access Panel - Front	AS-90631-10A	AS-90631-11A	AS-90631-11A
18		Front Corner Post	AS-90701-05A	AS-90701-05A	AS-90701-05A

No.	Notes	MODEL TECHNICAL VARIATION COOLING CAPACITY	RKKL- B 090	RKKL- B 120	RKKL- B 151
PANELS - RIGHT, REAR AND LEFT SIDES (Neutra Green, Before F4411)					
RIGHT:					
19		Air Stop	N/A	N/A	N/A
20		Louver Panel Assembly	AS-90789-03A	AS-90789-03A	AS-90789-03A
REAR:					
21		Rear Corner Post	AS-90702-04A	AS-90702-04A	AS-90702-04A
22		Condenser Coil Access Panel-Rear	AS-90631-03A	AS-90631-12A	AS-90631-12A
23		Rear Panel	AS-90618-02A	AS-90618-02A	AS-90618-02A
24		Supply Cover	AS-90626-02A	AS-90626-02A	AS-90626-02A
25		Return Cover	AS-90628-02A	AS-90628-02A	AS-90628-02A
LEFT:					
26		Upper Left Panel	AS-90624-03A	AS-90624-03A	AS-90624-03A
27		Lower Left Panel	AS-90624-04A	AS-90624-04A	AS-90624-04A
28		Left Corner Panel	AS-90755-10A	AS-90755-10A	AS-90755-10A
29		Plate - Receptacle	AS-90756-02A	AS-90756-02A	AS-90756-02A
30		Plate - Disconnect	AS-90756-03A	AS-90756-03A	AS-90756-03A
31		Button Plug (2)	45-22980-06	45-22980-06	45-22980-06
32		Button Plug	45-22980-05	45-22980-05	45-22980-05
TOP:					
33		Top Panel Assembly	AS-90616-06A	AS-90616-06A	AS-90616-06A
34		Condenser Top Panel	AS-102872-25A	AS-102872-21A	AS-102872-21A
35		Venturi	AS-90632-03A (1)	AS-90632-03A (2)	AS-90632-03A (2)
36		Wire Grille	95-100906-09 (1)	95-100906-09 (2)	95-100906-09 (2)
43		Drain Pan - Removable	See Coil Group		

No.	Notes	MODEL TECHNICAL VARIATION COOLING CAPACITY	RKKL- B 180	RKKL- B 240
PANELS - RAILS, BASE PANS, INSIDE CABINET (Granite/Steel Gray, After F4411)				
BASE RAILS:				
A		Front	AS-90827-03	AS-90827-03
B		Right	AE-90576-06	AE-90576-06
C		Rear	AS-90827-04	AS-90827-04
D		Left	AE-90576-05	AE-90576-05
BASE PANS:				
E		Outdoor Base Pan	AS-90583-17H	AS-90583-16H
F		Indoor Coil Base Pan - Return Air	AS-90577-09	AS-90577-09
G		Indoor Coil Base Pan - Supply Air	AS-90577-10	AS-90577-10
INSIDE CABINET PANEL/PIECES:				
H 1		Entry Plate	AE-90614-01	AE-90614-01
H 2		Entry Plate - Rooftop	AE-90614-01	AE-90614-01
J		Heat Compartment Side	AE-90598-06	AE-90598-06
K		Blower Deck Assembly	AS-90592-08	AS-90592-08
L		Wireway	AE-90718-04	AE-90718-04
M		Condenser Bulkhead (includes insulation)	AS-90609-13	AS-90609-32
O		Bulkhead Support	AE-102725-01	AE-102725-01
P		Primary Drain Pan	AS-103030-02	AS-103030-02
		Air Stop - Outdoor Coil- Front	AE-90706-21	AE-90706-21
		Air Stop - Outdoor Coil- Rear	AE-90706-20	AE-90706-20
U		Coil Support Top	N/A	AE-102700-07
V		Angle - Tube Support (2)	AE-90600-02	AE-90600-02

No.	Notes	MODEL TECHNICAL VARIATION COOLING CAPACITY	RKKL- B 180	RKKL- B 240
PANELS - FRONT AND RIGHT SIDES (Granite/Steel Gray, After F4411)				
1		Control Box Door Assembly - w/Hinges, Gasket, Insulation	AS-102872-03H	AS-102872-03H
2a		Bracket - Top Panel (Left)	AS-102859-01H	AS-102859-01H
2b		Bracket - Top Panel (Center)	AS-102969-01H	AS-102969-01H
2c		Post - Blower Section	AS-102682-21H	AS-102682-21H
3a		Bracket - Bottom Panel (Left)	AS-102859-02H	AS-102859-02H
3b		Bracket - Blower/Heater Compartment	AS-102859-04H	AS-102859-04H
3c		Bracket - Bottom Panel (Right)	AS-102859-05H	AS-102859-05H
4		Post Assembly - Indoor Coil Section	AS-90620-15H	AS-90620-15H
5		Control Box Cover	AE-90713-05	AE-90713-05
6		Control Mounting Panel	AE-90712-05	AE-90712-05
7a		Low Voltage Shield - Control Box (Upper Right)	AE-90742-07	AE-90742-07
7b		Low Voltage Shield - Control Box (Lower Left)	AE-90742-06	AE-90742-06
7c		Thermostat Chase Cover	AE-102722-01	AE-102722-01
8		Control Box Back	AS-90601-05	AS-90601-05
9		Mounting Bracket	AE-90779-02	AE-90779-02
		Outlet Flue Hood	AS-102966-01	AS-102966-01
	5	Inlet Flue Hood (2) - See Note 5	AE-90745-04	AE-90745-04
12	5	Gas Heat Access Panel Assembly - w/Hinges, Gasket - See Note 5	AS-102872-08H	AS-102872-09H
13		Power Entry Plate Assembly	AS-90774-12H	AS-90774-12H
14		Blower Access Panel Assembly - w/Hinges, Gasket, Insulation	AS-102872-01H	AS-102872-01H
16		Mounting Frame - Heat Exchanger Frame	AS-90754-03	AS-90754-03
17		Condenser Coil Access Panel - Front	AS-90734-16H	AS-90734-14H

No.	Notes	MODEL TECHNICAL VARIATION COOLING CAPACITY	RKKL- B 180	RKKL- B 240
PANELS - REAR, LEFT, AND TOP (Granite/Steel Gray, After F4411)				
REAR:				
22		Condenser Coil Access Panel-Rear	AS-90734-17H	AS-90734-15H
23		Rear Panel - Right	AS-90618-10H	AS-90618-10H
24		Supply Cover	AS-90628-03H	AS-90628-03H
25		Return Cover	AS-90628-04H	AS-90628-04H
LEFT:				
26		Upper Left Panel	AS-90624-09H	AS-90624-09H
27		Lower Left Panel	AS-90624-08H	AS-90624-08H
28		Left Corner Panel Assembly	AS-90755-05H	AS-90755-05H
		Bracket - Left Corner Panel Assembly (2)	AE-90779-01	AE-90779-01
		Gasket for receptacle plate	68-42514-08	68-42514-08
		Gasket for disconnect plate	68-42514-09	68-42514-09
29		Plate - Install inside Panel-Receptacle	AS-90756-02H	AS-90756-02H
30		Plate - Install inside Panel-Disconnect	AS-90756-03H	AS-90756-03H
31		Button Plug (3)	45-42558-01	45-42558-01
32		Star Bushing (3)	45-18515-01	45-18515-01
TOP:				
33a		Top Panel Assembly - Right	AS-90616-04H	AS-90616-04H
33b		Top Panel Assembly - Left	AS-90616-05H	AS-90616-05H
34		Top Panel	AS-90703-11H	AS-90703-11H
35		Venturi	AS-90632-03H (3)	AS-90632-03H (6)
36		Wire Grille	95-100906-09 (3)	95-100906-09 (6)
43		Drain Pan - Removable	See Coil Group	

No.	Notes	MODEL TECHNICAL VARIATION COOLING CAPACITY	RKKL- B 180	RKKL- B 240
PANELS - RAILS, BASE PANS, INSIDE CABINET (Neutra Green, Before F4411)				
BASE RAILS:				
A		Front	AS-90827-03	AS-90827-03
B		Right	AE-90576-06	AE-90576-06
C		Rear	AS-90827-04	AS-90827-04
D		Left	AE-90576-05	AE-90576-05
BASE PANS:				
E		Outdoor Base Pan	AS-90583-17A	AS-90583-16A
F		Indoor Coil Base Pan - Return Air	AS-90577-09	AS-90577-09
G		Indoor Coil Base Pan - Supply Air	AS-90577-10	AS-90577-10
INSIDE CABINET PANEL/PIECES:				
H 1		Entry Plate	AE-90614-01	AE-90614-01
H 2		Entry Plate - Rooftop	AE-90614-01	AE-90614-01
J		Heat Compartment Side	AE-90598-06	AE-90598-06
K		Blower Deck Assembly	AS-90592-08	AS-90592-08
L		Wireway	AE-90718-04	AE-90718-04
M		Condenser Bulkhead (includes insulation)	AS-90609-13	AS-90609-32
O		Bulkhead Support	AE-102725-01	AE-102725-01
P		Primary Drain Pan	AS-103030-02	AS-103030-02
		Air Stop - Outdoor Coil- Front	AE-90706-21	AE-90706-21
		Air Stop - Outdoor Coil- Rear	AE-90706-20	AE-90706-20
U		Coil Support Top	N/A	AE-102700-07
V		Angle - Tube Support (2)	AE-90600-02	AE-90600-02

No.	Notes	MODEL TECHNICAL VARIATION COOLING CAPACITY	RKKL- B 180	RKKL- B 240
PANELS - FRONT AND RIGHT SIDES (Neutra Green, Before F4411)				
1		Control Box Door Assembly - w/Hinges, Gasket, Insulation	AS-102872-03A	AS-102872-03A
2a		Bracket - Top Panel (Left)	AS-102859-01A	AS-102859-01A
2b		Bracket - Top Panel (Center)	AS-102969-01A	AS-102969-01A
2c		Post - Blower Section	AS-102682-21A	AS-102682-21A
3a		Bracket - Bottom Panel (Left)	AS-102859-02A	AS-102859-02A
3b		Bracket - Blower/Heater Compartment	AS-102859-04A	AS-102859-04A
3c		Bracket - Bottom Panel (Right)	AS-102859-05A	AS-102859-05A
4		Post Assembly - Indoor Coil Section	AS-90620-15A	AS-90620-15A
5		Control Box Cover	AE-90713-05	AE-90713-05
6		Control Mounting Panel	AE-90712-05	AE-90712-05
7a		Low Voltage Shield - Control Box (Upper Right)	AE-90742-07	AE-90742-07
7b		Low Voltage Shield - Control Box (Lower Left)	AE-90742-06	AE-90742-06
7c		Thermostat Chase Cover	AE-102722-01	AE-102722-01
8		Control Box Back	AS-90601-05	AS-90601-05
9		Mounting Bracket	AE-90779-02	AE-90779-02
		Outlet Flue Hood	AS-102966-01	AS-102966-01
	5	Inlet Flue Hood (2) - See Note 5	AE-90745-04	AE-90745-04
12	5	Gas Heat Access Panel Assembly - w/Hinges, Gasket - See Note 5	AS-102872-08A	AS-102872-09A
13		Power Entry Plate Assembly	AS-90774-12A	AS-90774-12A
14		Blower Access Panel Assembly - w/Hinges, Gasket, Insulation	AS-102872-01A	AS-102872-01A
16		Mounting Frame - Heat Exchanger Frame	AS-90754-03	AS-90754-03
17		Condenser Coil Access Panel - Front	AS-90734-16A	AS-90734-14A

No.	Notes	MODEL TECHNICAL VARIATION COOLING CAPACITY	RKKL- B 180	RKKL- B 240
PANELS - REAR, LEFT, AND TOP (Neutra Green, Before F4411)				
		REAR:		
22		Condenser Coil Access Panel-Rear	AS-90734-17A	AS-90734-15A
23		Rear Panel - Right	AS-90618-10A	AS-90618-10A
24		Supply Cover	AS-90628-03A	AS-90628-03A
25		Return Cover	AS-90628-04A	AS-90628-04A
		LEFT:		
26		Upper Left Panel	AS-90624-09A	AS-90624-09A
27		Lower Left Panel	AS-90624-08A	AS-90624-08A
28		Left Corner Panel Assembly	AS-90755-05A	AS-90755-05A
		Bracket - Left Corner Panel Assembly (2)	AE-90779-01	AE-90779-01
		Gasket for receptacle plate	68-42514-08	68-42514-08
		Gasket for disconnect plate	68-42514-09	68-42514-09
29		Plate - Install inside Panel-Receptacle	AS-90756-02A	AS-90756-02A
30		Plate - Install inside Panel-Disconnect	AS-90756-03A	AS-90756-03A
31		Button Plug (3)	45-42558-01	45-42558-01
32		Star Bushing (3)	45-18515-01	45-18515-01
		TOP:		
33a		Top Panel Assembly - Right	AS-90616-04A	AS-90616-04A
33b		Top Panel Assembly - Left	AS-90616-05A	AS-90616-05A
34		Top Panel	AS-90703-11A	AS-90703-11A
35		Venturi	AS-90632-03A (3)	AS-90632-03A (6)
36		Wire Grille	95-100906-09 (3)	95-100906-09 (6)
43		Drain Pan - Removable	See Coil Group	

No.	Notes	MODEL TECHNICAL VARIATION COOLING CAPACITY ELECTRICAL DESIGNATION	RKKL- B 072 C	RKKL- B 072 D	RKKL- B 072 Y
ELECTRIC GROUP					
CONTROL BOX COMPONENTS:					
	Stk	Integrated Furnace Control (IFC)	62-23599-03	62-23599-03	62-23599-03
		Wiring Harness - 9 pin from IFC to 9 terminals	45-102393-03	45-102393-03	45-102393-03
		Wiring Harness - Economizer (9 pin)	45-42522-116	45-42522-116	45-42522-116
		Wiring Harness - Economizer (12 pin)	45-42522-108	45-42522-108	45-42522-108
		Bypass Plug - Economizer 12 Pin	AS-61997-55	AS-61997-55	AS-61997-55
38	Stk	Belt Drive Blower Contactor	42-102664-03	42-102664-08	42-102664-03
39		Compressor Time Delay Relay	See Accessories		
40		Compressor Contactor	See Compressor Group		
		Low Ambient Control	See Accessories		
43	Stk	Transformer	46-103324-01	46-103324-02	46-103324-01
	Stk	Transformer - Step Down	N/A	N/A	46-23585-01
44		Auxiliary Limit - Blower Extension	47-17359-30	47-17359-30	47-17359-30
	Stk	Pressure Switch	42-24335-20	42-24335-20	42-24335-20
48	Stk	Inducer Blower Motor - Including Gasket	70-23641-01	70-23641-02	70-23641-01
49	Stk	Inducer Blower Motor Gasket	68-23643-01	68-23643-01	68-23643-01
50		Low Pressure Control	47-102240-03	47-102240-03	47-102240-03
51		High Pressure Control	47-23699-05	47-23699-05	47-23699-05

No.	Notes	MODEL TECHNICAL VARIATION COOLING CAPACITY ELECTRICAL DESIGNATION	RKKL- B 072 C	RKKL- B 072 D	RKKL- B 072 Y
FAN GROUP					
35	Stk	Fan Motor	51-100998-13	51-100998-12	51-100998-28
36	Stk	Fan Blade	70-42484-01	70-42484-01	70-42484-01
37	Stk	Capacitor - Fan Motor	43-100496-12	43-100496-12	43-100496-11

No.	Notes	MODEL TECHNICAL VARIATION COOLING CAPACITY ELECTRICAL DESIGNATION	RKKL- B 090 C	RKKL- B 120 C	RKKL- B 151 C
ELECTRICAL GROUP					
CONTROL BOX COMPONENTS:					
57a	Stk	Transformer - Control	46-42515-01	46-42515-01	46-42515-01
58a		Double Row Terminal Block	45-42548-02	45-42548-02	45-42548-02
58c		Ground Lug	45-19000-02	45-19000-02	45-19000-02
59	Stk	Contacto - Blower	42-102664-08	42-102664-08	42-102664-08
60		Capacitor - Fan Motor		See Fan Group	
		Capacitor Strap	AE-50892-01	AE-50892-01	AE-50892-01
		High Pressure Control		See Coil Group	
		Low Pressure Control		See Coil Group	
61a		Integrated Furnace Control Board (IFC)		See Gas Controls	
61b		Pressure Control Board - On or after F4112	47-104319-02	47-104319-02	47-104319-02
62	Stk	Contacto - Compressor	42-102664-08	42-102664-19	42-102664-08
WIRING HARNESES:					
		Wiring Harness - Fan Motor #1		See Fan Group	
		Wiring Harness - Fan Motor #2		See Fan Group	
		Wiring Harness - Twist-Loc 12 Pin to 9 Pin	45-102706-05	45-102706-05	45-102706-05
		Wiring Harness - Twist-Loc (12 Pin to 3 Pin and 7 Connectors) (15E)	45-102706-06	45-102706-06	45-102706-06
		Wiring Harness - Twist-Loc (12 Pin to 10 Connectors) (22E, 25E)	45-102706-10	45-102706-10	45-102706-10
		Plug Harness - Compressor		See Compressor Group	
		Wirng Harness - Induced Draft Blower	45-42522-19	45-42522-19	45-42522-19
		Bypass Plug - Economizer 12 Pin	AS-61997-55	AS-61997-55	AS-61997-55
		High/Low Pressure Switch Assembly (Includes both Switches and Wiring Harness)		See Coil Group	

No.	Notes	MODEL TECHNICAL VARIATION COOLING CAPACITY ELECTRICAL DESIGNATION	RKKL- B 090 D	RKKL- B 120 D	RKKL- B 151 D
ELECTRICAL GROUP					
CONTROL BOX COMPONENTS:					
57a	Stk	Transformer - Control	46-42515-02	46-42515-02	46-42515-02
58a		Double Row Terminal Block	45-42548-02	45-42548-02	45-42548-02
58c		Ground Lug	45-19000-02	45-19000-02	45-19000-02
59	Stk	Contacto - Blower	42-102664-08	42-102664-08	42-102664-08
60		Capacitor - Fan Motor		See Fan Group	
		Capacitor Strap	AE-50892-01	AE-50892-01	AE-50892-01
		High Pressure Control		See Coil Group	
		Low Pressure Control		See Coil Group	
61a		Integrated Furnace Control Board (IFC)		See Gas Controls	
61b		Pressure Control Board - On or after F4112	47-104319-02	47-104319-02	47-104319-02
62	Stk	Contacto - Compressor	42-102664-08	42-102664-19	42-102664-08
WIRING HARNESES:					
		Wiring Harness - Fan Motor #1		See Fan Group	
		Wiring Harness - Fan Motor #2		See Fan Group	
		Wiring Harness - Twist-Loc 12 Pin to 9 Pin	45-102706-05	45-102706-05	45-102706-05
		Wiring Harness - Twist-Loc (12 Pin to 3 Pin and 7 Connectors) (15E)	45-102706-06	45-102706-06	45-102706-06
		Wiring Harness - Twist-Loc (12 Pin to 10 Connectors) (22E, 25E)	45-102706-10	45-102706-10	45-102706-10
		Plug Harness - Compressor		See Compressor Group	
		Wirng Harness - Induced Draft Blower	45-42522-19	45-42522-19	45-42522-19
		Bypass Plug - Economizer 12 Pin	AS-61997-55	AS-61997-55	AS-61997-55
		High/Low Pressure Switch Assembly (Includes both switches and Wiring Harness)		See Coil Group	

No.	Notes	MODEL TECHNICAL VARIATION COOLING CAPACITY ELECTRICAL DESIGNATION	RKKL- B 090 Y	RKKL- B 120 Y	RKKL- B 151 Y
ELECTRICAL GROUP					
CONTROL BOX COMPONENTS:					
57a	Stk	Transformer - Control	46-42515-01	46-42515-01	46-42515-01
57b	Stk	Transformer - Power Step Down (2)	46-23585-01	46-23585-01	46-23585-01
58a		Double Row Terminal Block	45-42548-02	45-42548-02	45-42548-02
58c		Ground Lug	45-19000-02	45-19000-02	45-19000-02
59	Stk	Contacto - Blower	42-102664-08	42-102664-08	42-102664-08
60		Capacitor - Fan Motor	See Fan Group		
		Capacitor Strap	AE-50892-01	AE-50892-01	AE-50892-01
		High Pressure Control	See Coil Group		
		Low Pressure Control	See Coil Group		
61a		Integrated Furnace Control Board (IFC)	See Gas Controls		
61b		Pressure Control Board - On or after F4112	47-104319-02	47-104319-02	47-104319-02
62	Stk	Contacto - Compressor	42-102664-08	42-102664-19	42-102664-08
WIRING HARNESES:					
		Wiring Harness - Fan Motor #1	See Fan Group		
		Wiring Harness - Fan Motor #2	See Fan Group		
		Wiring Harness - Twist-Loc 12 Pin to 9 Pin	45-102706-05	45-102706-05	45-102706-05
		Wiring Harness - Twist-Loc (12 Pin to 10 Connectors) (22E, 25E)	45-102706-10	45-102706-10	45-102706-10
		Plug Harness - Compressor	See Compressor Group		
		Wiring Harness - Induced Draft Blower	45-42522-19	45-42522-19	45-42522-19
		Bypass Plug - Economizer 12 Pin	AS-61997-55	AS-61997-55	AS-61997-55
		High/Low Pressure Switch Assembly (Includes both Switches and Wiring Harness)	See Coil Group		

No.	Notes	MODEL TECHNICAL VARIATION COOLING CAPACITY ELECTRICAL DESIGNATION	RKKL-	RKKL-
			B 180 C	B 240 C
ELECTRIC GROUP				
CONTROL BOX COMPONENTS:				
57a	Stk	Transformer - Control	46-42515-04	46-42515-04
58a		Terminal Block - Double Row	45-42548-02	45-42548-02
58b		Terminal Block	45-21134-04	45-21134-04
58c		Ground Lug	45-19000-02	45-19000-02
59	Stk	Contactors - Blower	42-102664-08	42-102664-08
60		Run Capacitor		See Fan Group
		High Pressure Control		See Coil Group
		Low Pressure Control		See Coil Group
61a		Integrated Furnace Control Board (IFC)		See Gas Controls
61b		Pressure Control Board - On or after F4112	47-104319-02	47-104319-02
62a	Stk	Compressor Contactor	42-102664-12	42-22464-04
62b	Stk	Compressor Contactor	42-102664-12	42-22464-04
WIRING HARNESES:				
		Wiring Harness - Fan Motor #1		See Fan Group
		Wiring Harness - Fan Motor #2		See Fan Group
		Wiring Harness - Fan Motor #3		See Fan Group
		Plug Harness - Compressor		See Compressor Group
		Bypass Plug - Economizer 12 Pin	AS-61997-55	AS-61997-55
		Wiring Harness - Induced Draft Blower (25E)	45-42522-87	N/A
		Wiring Harness - Induced Draft Blower (30E,35E)	45-42522-86	45-42522-86
		Wiring Harness - Induced Draft Blower (40E)	N/A	45-42522-90
		Wiring Harness - Economizer (12 pin to 9 pin)	45-42522-89	45-42522-89
		Wiring Harness - Furnace Control	45-42522-88	45-42522-88
		Wiring Harness - Pressure Control Board to Pressure Switches (On or after F4112)	45-42522-123	45-42522-123
		High/Low Pressure Switch Assembly (Includes both Switches and Wiring Harness)		See Coil Group

No.	Notes	MODEL TECHNICAL VARIATION COOLING CAPACITY ELECTRICAL DESIGNATION	RKKL-	RKKL-
			B 180 D	B 240 D
ELECTRIC GROUP				
CONTROL BOX COMPONENTS:				
57a	Stk	Transformer - Control	46-42515-05	46-42515-05
58a		Terminal Block - Double Row	45-42548-02	45-42548-02
58b		Terminal Block	45-21134-04	45-21134-04
58c		Ground Lug	45-19000-02	45-19000-02
59	Stk	Contactors - Blower	42-102664-08	42-22464-01
60		Run Capacitor		See Fan Group
		High Pressure Control		See Coil Group
		Low Pressure Control		See Coil Group
61a		Integrated Furnace Control		See Gas Controls
61b		Pressure Control Board - On or after F4112	47-104319-02	47-104319-02
62a	Stk	Compressor Contactor	42-102664-12	42-22464-04
62b	Stk	Compressor Contactor	42-102664-12	42-22464-04
WIRING HARNESES:				
		Wiring Harness - Motor #1		See Fan Group
		Wiring Harness - Motor #2		See Fan Group
		Plug Harness - Compressor		See Compressor Group
		Bypass Plug - Economizer 12 Pin	AS-61997-55	AS-61997-55
		Wiring Harness - Induced Draft Blower (25E)	45-42522-87	N/A
		Wiring Harness - Induced Draft Blower (30E,35E)	45-42522-86	45-42522-86
		Wiring Harness - Induced Draft Blower (40E)	N/A	45-42522-90
		Wiring Harness - Economizer (12 pin to 9 pin)	45-42522-89	45-42522-89
		Wiring Harness - Furnace Control	45-42522-88	45-42522-88
		Wiring Harness - Pressure Control Board to Pressure Switches (On or after F4112)	45-42522-123	45-42522-123
		High/Low Pressure Switch Assembly (Includes both Switches and Wiring Harness)		See Coil Group

No.	Notes	MODEL TECHNICAL VARIATION COOLING CAPACITY ELECTRICAL DESIGNATION	RKKL- B 180 Y	RKKL- B 240 Y
ELECTRIC GROUP				
CONTROL BOX COMPONENTS:				
57a	Stk	Transformer - Control	46-42515-04	46-42515-04
57b	Stk	Transformer - Power Step Down	46-23585-01 (3)	46-23585-01 (4)
58a		Terminal Block - Double Row	45-42548-02	45-42548-02
58b		Terminal Block	45-21134-04	45-21134-04
58c		Ground Lug	45-19000-02	45-19000-02
59	Stk	Contactator - Blower	42-102664-08	42-102664-08
60		Run Capacitor	See Fan Group	
		High Pressure Control	See Coil Group	
		Low Pressure Control	See Coil Group	
61a		Integrated Furnace Control	See Gas Controls	
61b		Pressure Control Board - On or after F4112	47-104319-02	47-104319-02
62a	Stk	Compressor Contactator	42-102664-12	42-22464-04
62b	Stk	Compressor Contactator	42-102664-12	42-22464-04
WIRING HARNESES:				
		Wiring Harness - Motor #1	See Fan Group	
		Wiring Harness - Motor #2	See Fan Group	
		Plug Harness - Compressor	See Compressor Group	
		Bypass Plug - Economizer 12 Pin	AS-61997-55	AS-61997-55
		Wiring Harness - Induced Draft Blower (35E)	45-42522-86	N/A
		Wiring Harness - Induced Draft Blower (40E)	N/A	45-42522-90
		Wiring Harness - Economizer (12 pin to 9 pin)	45-42522-89	45-42522-89
		Wiring Harness - Furnace Control	45-42522-88	45-42522-88
		Wiring Harness - Pressure Control Board to Pressure Switches (On or after F4112)	45-42522-123	45-42522-123
		High/Low Pressure Switch Assembly (Includes both Switches and Wiring Harness)	See Coil Group	

No.	Notes	MODEL TECHNICAL VARIATION COOLING CAPACITY ELECTRICAL DESIGNATION	RKKL- B 090 C	RKKL- B 120 C	RKKL- B 151 C
FAN GROUP					
52	Stk	Fan Motor	51-42534-29 (1)	51-42534-24 (2)	51-42534-29 (2)
		Wiring Harness - Motor #1 (before F4112)	45-102706-17	45-102706-18	45-102706-03
		Wiring Harness - Motor #1 (on or after F4112)	45-102706-25	45-102706-26	45-102706-24
		Wiring Harness - Motor #2 (before F4112)	N/A	45-102706-19	45-102706-04
		Wiring Harness - Motor #2 (on or after F4112)	N/A	45-102706-23	45-102706-27
53	Stk	Fan Blade	70-103693-01 (1)	70-42572-04 (2)	70-103693-01 (2)
60	Stk	Capacitor - Fan Motor	43-100496-17 (1)	43-100496-12 (2)	43-100496-17 (2)

No.	Notes	MODEL TECHNICAL VARIATION COOLING CAPACITY ELECTRICAL DESIGNATION	RKKL- B 090 D	RKKL- B 120 D	RKKL- B 151 D
FAN GROUP					
52	Stk	Fan Motor	51-42534-28 (1)	51-42534-25 (2)	51-42534-28 (2)
		Wiring Harness - Motor #1 (before F4112)	45-102706-17	45-102706-18	45-102706-03
		Wiring Harness - Motor #1 (on or after F4112)	45-102706-25	45-102706-26	45-102706-24
		Wiring Harness - Motor #2 (before F4112)	N/A	45-102706-19	45-102706-04
		Wiring Harness - Motor #2 (on or after F4112)	N/A	45-102706-23	45-102706-27
53	Stk	Fan Blade	70-103693-01 (1)	70-42572-04 (2)	70-103693-01 (2)
60	Stk	Capacitor - Fan Motor	43-100496-12 (1)	43-100496-12 (2)	43-100496-12 (2)

No.	Notes	MODEL TECHNICAL VARIATION COOLING CAPACITY ELECTRICAL DESIGNATION	RKKL- B 090 Y	RKKL- B 120 Y	RKKL- B 151 Y
FAN GROUP					
52	Stk	Fan Motor	51-42534-27 (1)	51-42534-26 (2)	51-42534-27 (2)
		Wiring Harness - Motor #1 (before F4112)	45-102706-17	45-102706-18	45-102706-03
		Wiring Harness - Motor #1 (on or after F4112)	45-102706-25	45-102706-26	45-102706-24
		Wiring Harness - Motor #2 (before F4112)	N/A	45-102706-19	45-102706-04
		Wiring Harness - Motor #2 (on or after F4112)	N/A	45-102706-23	45-102706-27
53	Stk	Fan Blade	70-103693-01 (1)	70-42572-04 (2)	70-103693-01 (2)
60	Stk	Capacitor - Fan Motor	43-100496-48 (1)	43-100496-12 (2)	43-100496-48 (2)

No.	Notes	MODEL TECHNICAL VARIATION COOLING CAPACITY ELECTRICAL DESIGNATION	RKKL- B 180 C	RKKL- B 240 C
FAN GROUP				
52	Stk	Fan Motor	51-42534-29 (3)	51-42534-29 (3)
		Wiring Harness - Motor #1, #2	45-42522-71	45-42522-71
		Wiring Harness - Motor #3	45-42522-114	45-42522-114
53	Stk	Fan Blade	70-103693-01 (3)	70-103693-01 (3)
60	Stk	Capacitor - Fan Motor	43-100496-17 (3)	43-100496-17 (3)

No.	Notes	MODEL TECHNICAL VARIATION COOLING CAPACITY ELECTRICAL DESIGNATION	RKKL- B 180 D	RKKL- B 240 D
FAN GROUP				
52	Stk	Fan Motor	51-42534-28 (3)	51-42534-28 (3)
		Wiring Harness - Motor #1, #2	45-42522-71	45-42522-71
		Wiring Harness - Motor #3	45-42522-114	45-42522-114
53	Stk	Fan Blade	70-103693-01 (3)	70-103693-01 (3)
60	Stk	Capacitor - Fan Motor	43-100496-12 (3)	43-100496-12 (3)

No.	Notes	MODEL TECHNICAL VARIATION COOLING CAPACITY ELECTRICAL DESIGNATION	RKKL- B 180 Y	RKKL- B 240 Y
FAN GROUP				
52	Stk	Fan Motor	51-42534-27 (3)	51-42534-27 (3)
		Wiring Harness - Motor #1, #2	45-42522-71	45-42522-71
		Wiring Harness - Motor #3	45-42522-114	45-42522-114
53	Stk	Fan Blade	70-103693-01 (3)	70-103693-01 (3)
60	Stk	Capacitor - Fan Motor	43-100496-48 (3)	43-100496-48 (3)

No.	Notes	MODEL	RKKL-	RKKL-	RKKL-	RKKL-	RKKL-	RKKL-
		TECHNICAL VARIATION	B	B	B	B	B	B
		COOLING CAPACITY	072	072	072	072	072	072
		ELECTRICAL DESIGNATION	C	C	D	D	Y	Y
		DRIVE PACKAGE	L	M	L	M	L	M
BLOWER GROUP - BELT DRIVE								
62	Stk	Blower Assembly (Items 63-73, Excluding Cross Brace)	AS-101336-03	AS-101336-03	AS-101336-03	AS-101336-03	AS-101336-03	AS-101336-03
63		Housing	AS-101342-01	AS-101342-01	AS-101342-01	AS-101342-01	AS-101342-01	AS-101342-01
64		Bearing Frame Tri-Arm (2)	70-41723-02	70-41723-02	70-41723-02	70-41723-02	70-41723-02	70-41723-02
65	Stk	Ball Bearing And Cushion (2)	70-41911-01	70-41911-01	70-41911-01	70-41911-01	70-41911-01	70-41911-01
66	Stk	Blower Shaft	70-21933-02	70-21933-02	70-21933-02	70-21933-02	70-21933-02	70-21933-02
67	Stk	Fixed Pitch Sheave	71-100772-03	71-100772-03	71-100772-03	71-100772-03	71-100772-03	71-100772-03
68		Blower Support - Left	AE-58950-03	AE-58950-03	AE-58950-03	AE-58950-03	AE-58950-03	AE-58950-03
69	Stk	Blower Wheel	70-21773-01	70-21773-01	70-21773-01	70-21773-01	70-21773-01	70-21773-01
70		Cut-Off Tabulation	AE-64401-18	AE-64401-18	AE-64401-18	AE-64401-18	AE-64401-18	AE-64401-18

No.	Notes	MODEL	RKKL-	RKKL-	RKKL-	RKKL-	RKKL-	RKKL-
		TECHNICAL VARIATION	B	B	B	B	B	B
		COOLING CAPACITY	072	072	072	072	072	072
		ELECTRICAL DESIGNATION	C	C	D	D	Y	Y
		DRIVE PACKAGE	L	M	L	M	L	M
BLOWER MOTOR MOUNTING - BELT DRIVE								
MOTOR MOUNTING:								
71		Blower Bracket	AE-101124-05	AE-101124-05	AE-101124-05	AE-101124-05	AE-101124-05	AE-101124-05
72		Blower Bracket - Drive Side	AE-101124-03	AE-101124-03	AE-101124-03	AE-101124-03	AE-101124-03	AE-101124-03
72a		Grommet	56-18518-04	56-18518-04	56-18518-04	56-18518-04	56-18518-04	56-18518-04
72b		Cross Brace	AE-101467-01	AE-101467-01	AE-101467-01	AE-101467-01	AE-101467-01	AE-101467-01
73		Motor Mount Assembly	AS-101340-01	AS-101340-01	AS-101340-01	AS-101340-01	AS-101340-01	AS-101340-01

No.	Notes	MODEL	RKKL-	RKKL-	RKKL-	RKKL-	RKKL-	RKKL-
		TECHNICAL VARIATION	B	B	B	B	B	B
		COOLING CAPACITY	072	072	072	072	072	072
		ELECTRICAL DESIGNATION	C	C	D	D	Y	Y
		DRIVE PACKAGE	L	M	L	M	L	M
BLOWER MOTOR GROUP - BELT DRIVE								
74		Blower Motor	51-41936-02	51-41936-02	51-41936-02	51-41936-02	51-42177-10	51-42177-10
75		Variable Pitch Sheave	71-40427-29	71-40427-25	71-40427-29	71-40427-25	71-40427-29	71-40427-25
76		Belt	71-40235-42	71-40235-43	71-40235-42	71-40235-43	71-40235-42	71-40235-43

No.	Notes	MODEL TECHNICAL VARIATION COOLING CAPACITY DRIVE PACKAGE	RKKL-	RKKL-	RKKL-
			B 090 L	B 120 L	B 151 L
BLOWER ASSEMBLY GROUP - BELT DRIVE					
64	Stk	Blower Assembly (w/o Motor Mount, Belt, Fixed Sheave, and Key)	AS-90757-01	AS-90757-01	AS-90757-01
65	Stk	Blower Wheel	70-42540-02	70-42540-02	70-42540-02
66		Bearing Frame Tri-Arm (2)	70-42540-05	70-42540-05	70-42540-05
67		Bearing with Bearing Lock (2)	70-41854-02	70-41854-02	70-41854-02
68	Stk	Blower Shaft	70-42540-04	70-42540-04	70-42540-04
69		Blower Mounting Angles (2)	AE-90708-01	AE-90708-01	AE-90708-01
		Blower Angle Stop	AE-90709-02	AE-90709-02	AE-90709-02
70		Motor Mount	AS-90824-01	AS-90824-01	AS-90824-01
71	Stk	Blower Motor - C/D Voltages	51-42536-01	51-42536-01	51-42537-01
71	Stk	Blower Motor - Y Voltage	51-42536-02	51-42536-02	51-42537-02
72	Stk	Variable Sheave	71-42538-02	71-42538-02	71-42538-02
73	Stk	Belt	71-40438-30	71-40438-27	71-40438-23
74	Stk	Fixed Sheave	71-100774-05	71-100774-02	71-100774-01
		Key	94-42551-09	94-42551-09	94-42551-09
	Stk	Bushing for Sheave w/Screws	71-100773-01	71-100773-01	71-100773-01

No.	Notes	MODEL TECHNICAL VARIATION COOLING CAPACITY DRIVE PACKAGE	RKKL-	RKKL-	RKKL-
			B 090 M	B 120 M	B 151 M
BLOWER ASSEMBLY GROUP - BELT DRIVE					
64	Stk	Blower Assembly (w/o Motor Mount, Belt, Fixed Sheave, and Key)	AS-90757-01	AS-90757-01	AS-90757-01
65	Stk	Blower Wheel	70-42540-02	70-42540-02	70-42540-02
66		Bearing Frame Tri-Arm (2)	70-42540-05	70-42540-05	70-42540-05
67		Bearing with Bearing Lock (2)	70-41854-02	70-41854-02	70-41854-02
68	Stk	Blower Shaft	70-42540-04	70-42540-04	70-42540-04
69		Blower Mounting Angles (2)	AE-90708-01	AE-90708-01	AE-90708-01
		Blower Angle Stop	AE-90709-02	AE-90709-02	AE-90709-02
70		Motor Mount	AE-90710-04	AE-90710-04	AE-90710-04
71	Stk	Blower Motor - C/D Voltages	51-42536-01	51-42537-01	51-102826-06
71	Stk	Blower Motor - Y Voltage	51-42536-02	51-42537-02	51-102826-08
72	Stk	Variable Sheave	71-42538-02	71-42538-02	71-40427-11
73	Stk	Belt	71-40438-27	71-40438-23	71-40438-31
74	Stk	Fixed Sheave	71-100774-02	71-100774-04	71-26254-06
		Key	94-42551-09	94-42551-09	94-42551-09
	Stk	Bushing for Sheave w/Screws	71-100773-01	71-100773-01	71-100773-01

No.	Notes	MODEL TECHNICAL VARIATION COOLING CAPACITY DRIVE PACKAGE	RKKL-		
			B 090 N		
BLOWER ASSEMBLY GROUP - BELT DRIVE					
64	Stk	Blower Assembly (w/o Motor Mount, Belt, Fixed Sheave, and Key)	AS-90757-01		
65	Stk	Blower Wheel	70-42540-02		
66		Bearing Frame Tri-Arm (2)	70-42540-05		
67		Bearing with Bearing Lock (2)	70-41854-02		
68	Stk	Blower Shaft	70-42540-04		
69		Blower Mounting Angles (2)	AE-90708-01		
		Blower Angle Stop	AE-90709-02		
70		Motor Mount	AE-90710-04		
71	Stk	Blower Motor - C/D Voltages	51-42537-01		
71	Stk	Blower Motor - Y Voltage	51-42537-02		
72	Stk	Variable Sheave	71-42538-02		
73	Stk	Belt	71-40438-23		
74	Stk	Fixed Sheave	71-100774-04		
		Key	94-42551-09		
	Stk	Bushing for Sheave w/Screws	71-100773-01		

No.	Notes	MODEL TECHNICAL VARIATION COOLING CAPACITY DRIVE PACKAGE	RKKL-	RKKL-
			B 180 L	B 240 L
BLOWER ASSEMBLY GROUP - BELT DRIVE				
64	Stk	Blower Assembly (includes Bearing Frame and Blower Wheel) (2)	AS-90757-06	AS-90757-06
65	Stk	Blower Wheel (2)	70-42564-02	70-42564-02
66		Bearing Frame Tri-Arm (4)	70-42284-04	70-42284-04
67		Bearing with Bearing Lock (4)	70-41854-02	70-41854-02
68	Stk	Blower Shaft	70-42564-03	70-42564-03
69		Blower Connector Angles (3)	AE-90798-01	AE-90798-01
70		Motor Mount	AE-90710-03	AE-90710-03
71	Stk	Blower Motor - C/D Voltages	51-42537-01	51-102826-06
71	Stk	Blower Motor - Y Voltage	51-42537-02	51-102826-08
72	Stk	Variable Sheave	71-42538-02	71-40427-04
73	Stk	Belt	71-40438-43	71-40438-51
74a	Stk	Fixed Sheave	71-100774-08	71-100774-06
74b		Key	94-42551-09	94-42551-09
74c	Stk	Bushing for Sheave w/Screws	71-100773-01	71-100773-01

No.	Notes	MODEL TECHNICAL VARIATION COOLING CAPACITY DRIVE PACKAGE	RKKL-	RKKL-
			B 180 M	B 240 M
BLOWER ASSEMBLY GROUP - BELT DRIVE				
64	Stk	Blower Assembly (includes Bearing Frame and Blower Wheel) (2)	AS-90757-06	AS-90757-06
65	Stk	Blower Wheel (2)	70-42564-02	70-42564-02
66		Bearing Frame Tri-Arm (4)	70-42284-04	70-42284-04
67		Bearing with Bearing Lock (4)	70-41854-02	70-41854-02
68	Stk	Blower Shaft	70-42564-03	70-42564-03
69		Blower Connector Angles (3)	AE-90798-01	AE-90798-01
70		Motor Mount	AE-90710-03	AE-90710-03
71	Stk	Blower Motor - C/D Voltages	51-102826-06	51-102826-07
71	Stk	Blower Motor - Y Voltage	51-102826-08	51-102826-09
72	Stk	Variable Sheave	71-40427-04	71-40427-59
73	Stk	Belt	71-40438-46	71-40438-54
74a	Stk	Fixed Sheave	71-100774-08	71-100774-06
74b		Key	94-42551-09	94-42551-09
74c	Stk	Bushing for Sheave w/Screws	71-100773-01	71-100773-01

No.	Notes	MODEL TECHNICAL VARIATION COOLING CAPACITY ELECTRICAL DESIGNATION	RKKL- B 072 C	RKKL- B 072 D	RKKL- B 072 Y
COIL GROUP					
6		Filter Keeper	AE-59168-01	AE-59168-01	AE-59168-01
EVAPORATOR COIL:					
77	Stk	Evaporator Coil	AS-103213-01	AS-103213-01	AS-103213-01
78	Stk	TXV - Sporlan	61-42662-14	61-42662-14	61-42662-14
80		Top Air Stop	AE-58933-02	AE-58933-02	AE-58933-02
81		Top Coil Support	AE-58941-01	AE-58941-01	AE-58941-01
82		Filter Channels (3) Center Is Two Channels Back To Back	AE-58934-03	AE-58934-03	AE-58934-03
83		Indoor Coil Drain Pan	68-23559-02	68-23559-02	68-23559-02
CONDENSER COIL:					
84	Stk	Condenser Coil	AS-101717-01	AS-101717-01	AS-101717-01
	Stk	Filter Drier	83-22755-10	83-22755-10	83-22755-10
85		Filter - Disposable (4)	54-17531-24	54-17531-24	54-17531-24

No.	Notes	MODEL TECHNICAL VARIATION COOLING CAPACITY ELECTRICAL DESIGNATION	RKKL- B 072 C	RKKL- B 072 D	RKKL- B 072 Y
COMPRESSOR GROUP					
Compressor ID:			8056	8057	8058
86	Stk	Compressor	55-102471-14S	55-102471-16S	55-102471-15S
40	Stk	Contactora	42-102664-08	42-102664-08	42-102664-08
	Stk	Compressor Wiring Harness - Molded Plug	45-100834-10	45-100834-10	45-100834-10

No.	Notes	MODEL TECHNICAL VARIATION COOLING CAPACITY	RKKL- B 090	RKKL- B 120
COIL GROUP				
EVAPORATOR COIL GROUP:				
42	Stk	Evaporator Coil	AS-90656-76	AS-90656-82
	Stk	Distributor / Flowcheck Piston Assembly	61-102912-98	61-102912-120
43	Stk	Drain Pan - Removable	68-102699-02	68-102699-02
FILTER PIECES:				
44		Filter Frame	AE-90606-11	AE-90606-11
45		Air Stop - Bottom	AE-102712-10	AE-102712-10
46		Air Stop - Side	AE-102712-06	AE-102712-06
47		Top Air Stop Assembly	AS-90604-06	AS-90604-06
48		Filter Channel (2)	AE-102712-08	AE-102712-08
49		Filter Slide (2)	AE-102712-11	AE-102712-11
		Filter (6)	54-42541-01	54-42541-01
CONDENSER COIL GROUP:				
37a	Stk	Condenser Coil	65-101478-07	65-101478-07
37b	Stk	Condenser Coil	N/A	65-101478-07
		Access Valve Body	61-18542-01	61-18542-01
		Access Valve Core	61-18551-01	61-18551-01
38		Front Air Stop	AE-90706-19	N/A
39		Rear Air Stop	AE-90706-18	N/A
40a,b		Bottom Retainer (2)	AE-90700-03	AE-90700-02
40a		Micro-Channel Coil Mounting Base - Left	68-102752-01	68-102752-01
40b		Micro-Channel Coil Mounting Base - Right	68-102752-02	68-102752-02
41a		Top Support - Condenser Coil	N/A	AE-90612-13
41b		Top Support - Condenser Bulkhead	N/A	AE-90612-23
		Filter Drier - Liquid Line	83-40386-05	83-40386-05
		Strap - Filter Drier	N/A	AE-102132-01
	Stk	High Pressure Control - Before F4112	47-23699-05	47-23699-05
	Stk	High Pressure Control - On or After F4112	47-103669-01	47-103669-01
	Stk	Low Pressure Control	47-101529-09	47-101529-09
		High/Low Pressure Control Assembly (Includes both controls and Wiring Harness) - Before F4112	AS-102877-01	AS-102877-01

No.	Notes	MODEL TECHNICAL VARIATION COOLING CAPACITY	RKKL- B 151
COIL GROUP			
EVAPORATOR COIL GROUP:			
42	Stk	Evaporator Coil	AS-90656-75
	Stk	TXV - Circuit #1	61-101351-14
	Stk	TXV - Circuit #2	61-101351-14
		Bulb Strap Kit - TXV (2)	64-101357-01
43	Stk	Drain Pan - Removable	68-102699-02
FILTER PIECES:			
44		Filter Frame	AE-90606-11
45		Air Stop - Bottom	AE-102712-10
46		Air Stop - Side	AE-102712-06
47		Top Air Stop Assembly	AS-90604-06
48		Filter Channel (2)	AE-102712-08
49		Filter Slide (2)	AE-102712-11
		Filter (6)	54-42541-01
CONDENSER COIL GROUP:			
37a	Stk	Condenser Coil	65-101478-08
37b	Stk	Condenser Coil	65-101478-08
38		Front Air Stop	N/A
39		Rear Air Stop	N/A
40a		Micro-Channel Coil Mounting Base - Left	68-102752-01
40b		Micro-Channel Coil Mounting Base - Right	68-102752-02
41a		Top Support - Condenser Coil	AE-90612-13
41b		Top Support - Condenser Bulkhead	AE-90612-05
		Filter Drier - Liquid Line	83-22755-05 (2)
		Strap - Filter Drier	AE-102132-01 (2)
	Stk	High Pressure Control - Before F4112	47-23699-05 (2)
	Stk	High Pressure Control - On or After F4112	47-103669-01 (2)
	Stk	Low Pressure Control	47-101529-09 (2)
		High/Low Pressure Control Assembly (Includes both controls and Wiring Harness) - Before F4112	AS-102877-01 (2)

No.	Notes	MODEL TECHNICAL VARIATION COOLING CAPACITY	RKKL- B 180	RKKL- B 240
COIL GROUP				
EVAPORATOR COIL GROUP:				
40		Air Flow Panel - Neutra Green	AS-90828-02A	AS-90828-02A
40		Air Flow Panel - Granite/Steel Gray	AS-90828-02H	AS-90828-02H
42	Stk	Complete Coil - Indoor	AS-103697-01	AS-103697-03
	Stk	Distributor/Cap Tube Assembly - Circuit #1	83-103430-04	83-103430-01
	Stk	Distributor/Cap Tube Assembly - Circuit #2	83-103430-05	83-103430-02
43	Stk	Drain Pan - Removable	68-102699-01	68-102699-01
FILTER PIECES:				
44		Filter Frame	AE-90606-10	AE-90606-10
45	4	Air Stop - Bottom (Before F1811) - See Note 4	AE-102712-05	AE-102712-05
45		Air Stop - Bottom (After F1811)	AE-102712-17	AE-102712-17
46	4	Air Stop - Side (Before F1811) - See Note 4	AE-102712-01	AE-102712-01
46		Air Stop - Side (After F1811)	AE-102712-14	AE-102712-14
47		Top Air Stop Assembly	AS-90604-04	AS-90604-04
48	4	Filter Channel (2) (Before F1811) - See Note 4	AE-102712-03	AE-102712-03
48		Filter Channel (2) (After F1811)	AE-102712-16	AE-102712-16
49	4	Filter Slide (2) (Before F1811) - See Note 4	AE-102712-02	AE-102712-02
49		Filter Slide (2) (After F1811)	AE-102712-15	AE-102712-15
50		Filter - 20 in. x 25 in. x 2 in. (8)	54-42541-04	54-42541-04
CONDENSER COIL:				
37	Stk	Condenser Coil	65-101478-10 (1)	65-101478-09 (2)
37a		Coil Mounting Base - Left	68-102752-01	68-102752-01
37b		Coil Mounting Base - Right	68-102752-02	68-102752-02
38		Post - Outdoor Coil (Front) - Neutra Green	AS-90701-08A	AS-90701-08A
38		Post - Outdoor Coil (Front) - Granite/Steel Gray	AS-90701-08H	AS-90701-08H
38a		Air Stop - Front	N/A	AE-90706-21
39		Post - Outdoor Coil (Rear) - Neutra Green	AS-90702-06A	AS-90702-06A
39		Post - Outdoor Coil (Rear) - Granite/Steel Gray	AS-90702-06H	AS-90702-06H
39a		Air Stop - Rear	N/A	AE-90706-20
41a		Top Support - Inner Condenser Coil (2)	N/A	AE-90612-25
41b		Top Support - Condenser Bulkhead	N/A	AE-90612-24
		Filter Drier - Liquid Line (2)	83-22755-13	83-22755-13
	Stk	High Pressure Control - Before F4112	47-23699-05 (2)	47-23699-05 (2)
	Stk	High Pressure Control - On or After F4112	47-23699-04 (2)	47-23699-04 (2)
	Stk	Low Pressure Control	47-101529-09 (2)	47-101529-09 (2)
		High/Low Pressure Control Assembly (Includes both controls and Wiring Harness) - Before F4112	AS-102877-01	AS-102877-01

No.	Notes	MODEL TECHNICAL VARIATION COOLING CAPACITY ELECTRICAL DESIGNATION	RKKL- B 090 C	RKKL- B 120 C
COMPRESSOR GROUP				
		Compressor ID:	8289	8269
75	Stk	Compressor	55-102045-43S	55-102471-01S
	Stk	Plug Harness - Compressor	45-102708-01	45-102706-13
		Compressor ID:		8982
75	Stk	Compressor		55-102471-31S
		Adapter Plate		AE-104773-01
	Stk	Plug Harness - Compressor		45-102706-13

No.	Notes	MODEL TECHNICAL VARIATION COOLING CAPACITY ELECTRICAL DESIGNATION	RKKL- B 090 D	RKKL- B 120 D
COMPRESSOR GROUP				
		Compressor ID:	8290	8270
75	Stk	Compressor	55-102045-45S	55-102471-04S
	Stk	Plug Harness - Compressor	45-102708-01	45-102706-13
		Compressor ID:		8983
75	Stk	Compressor		55-102471-27S
		Adapter Plate		AE-104773-01
	Stk	Plug Harness - Compressor		45-102706-13

No.	Notes	MODEL TECHNICAL VARIATION COOLING CAPACITY ELECTRICAL DESIGNATION	RKKL- B 090 Y	RKKL- B 120 Y
COMPRESSOR GROUP				
		Compressor ID:	8291	8271
75	Stk	Compressor	55-102045-44S	55-102471-05S
	Stk	Plug Harness - Compressor	45-102708-01	45-102706-13
		Compressor ID:		8984
75	Stk	Compressor		55-102471-32S
		Adapter Plate		AE-104773-01
	Stk	Plug Harness - Compressor		45-102706-13

No.	Notes	MODEL	RKKL- B 151 C
		TECHNICAL VARIATION COOLING CAPACITY ELECTRICAL DESIGNATION	
COMPRESSOR GROUP			
		Compressor ID:	8311
75	Stk	Compressor #1	55-102471-14S
75	Stk	Compressor #2	55-102471-18S
	Stk	Plug Harness - Compressor #1	45-102708-03
	Stk	Plug Harness - Compressor #2	45-102708-04

No.	Notes	MODEL	RKKL- B 151 D
		TECHNICAL VARIATION COOLING CAPACITY ELECTRICAL DESIGNATION	
COMPRESSOR GROUP			
		Compressor ID:	8312
75	Stk	Compressor #1	55-102471-16S
75	Stk	Compressor #2	55-102471-19S
	Stk	Plug Harness - Compressor #1	45-102708-03
	Stk	Plug Harness - Compressor #2	45-102708-04

No.	Notes	MODEL	RKKL- B 151 Y
		TECHNICAL VARIATION COOLING CAPACITY ELECTRICAL DESIGNATION	
COMPRESSOR GROUP			
		Compressor ID:	8313
75	Stk	Compressor #1	55-102471-15S
75	Stk	Compressor #2	55-102471-17S
	Stk	Plug Harness - Compressor #1	45-102708-03
	Stk	Plug Harness - Compressor #2	45-102708-04

No.	Notes	MODEL TECHNICAL VARIATION COOLING CAPACITY ELECTRICAL DESIGNATION	RKKL- B 180 C	RKKL- B 240 C
COMPRESSOR GROUP				
		Compressor:	8348	8331
75	Stk	Compressor #1	55-23156-20S	55-102471-02S
75	Stk	Compressor #2	55-23156-29S	55-102471-01S
	Stk	Plug Harness - Compressor #1	45-42522-73	45-42522-73
	Stk	Plug Harness - Compressor #2	45-42522-72	45-42522-72
		Harness - High/Low Pressure Switch Assembly (includes High and Low Switches)	AS-102877-01	AS-102877-01

No.	Notes	MODEL TECHNICAL VARIATION COOLING CAPACITY ELECTRICAL DESIGNATION	RKKL- B 180 D	RKKL- B 240 D
COMPRESSOR GROUP				
		Compressor:	8349	8332
75	Stk	Compressor #1	55-23156-21S	55-102471-09S
75	Stk	Compressor #2	55-23156-30S	55-102471-04S
	Stk	Plug Harness - Compressor #1	45-42522-73	45-42522-73
	Stk	Plug Harness - Compressor #2	45-42522-72	45-42522-72
		Harness - High/Low Pressure Switch Assembly (includes High and Low Switches)	AS-102877-01	AS-102877-01

No.	Notes	MODEL TECHNICAL VARIATION COOLING CAPACITY ELECTRICAL DESIGNATION	RKKL- B 180 Y	RKKL- B 240 Y
COMPRESSOR GROUP				
		Compressor:	8350	8333
75	Stk	Compressor #1	55-23156-22S	55-102471-11S
75	Stk	Compressor #2	55-23156-31S	55-102471-05S
	Stk	Plug Harness - Compressor #1	45-42522-73	45-42522-73
	Stk	Plug Harness - Compressor #2	45-42522-72	45-42522-72
		Harness - High/Low Pressure Switch Assembly (includes High and Low Switches)	AS-102877-01	AS-102877-01

No.	Notes	MODEL TECHNICAL VARIATION COOLING CAPACITY HEATING CAPACITY	RKKL- B 072 10	RKKL- B 072 13
HEAT EXCHANGER, BURNER/MANIFOLD				
45	Stk	Main Limit - (Condenser Bulkhead) E - Electric	47-23610-19	47-23610-19
45	Stk	Main Limit - (Condenser Bulkhead) X - NOX	47-23610-19	47-23610-19
46		Main Limit Shield	AS-59152-01	AS-59152-01
87	Stk	Heat Exchanger - Includes Center Panel	AS-59066-05	AS-59066-04
88		Turbulators	AE-58922-01 (5)	AE-58922-01 (6)
89		NOX Inserts	N/A	N/A
90		Divider Plate Gasket	68-23680-02	68-23680-02
91		Divider Plate	AE-59067-01	AE-59067-01
92		Collector Box Gasket	68-23680-01	68-23680-01
93		Collector Box Cover	AE-59068-02	AE-59068-03
94		Flue Duct	75-23678-01	75-23678-01
95		Flue Duct Gasket	68-23680-03	68-23680-03
96		Burner Shield	AE-58886-01	AE-58886-01
97	Stk	Limit (Manual Reset)	47-22861-02 (2)	47-22861-02 (2)
98		Burner Compartment Floor	AE-58932-02	AE-58932-02

No.	Notes	MODEL TECHNICAL VARIATION COOLING CAPACITY HEATING CAPACITY	RKKL- B 072 10	RKKL- B 072 13
BURNER / MANIFOLD GROUP				
99	Stk, 1	Burner Assembly	AS-60993-05	AS-60993-06
99a		Bushing	45-42519-01	45-42519-01
100		Burner Support - (Holds the Burners between the Burner Support Brackets)	AE-102650-01	AE-102650-01
101		Burner Support Bracket (2)	AE-61588-02	AE-61588-02
102	Stk	Manifold Assembly (w/o Orifices)	81-101153-01	81-101153-01
103		Square Head Plug - (Used on Manifold to plug extra holes)	81-23593-01 (2)	81-23593-01 (1)
104		Burner Orifice - Natural Gas:	See Orifice Selection Chart	
104		Burner Orifice - LP:		
104		Number of Orifices		
105	Stk	Flame Sensor	62-23543-02	62-23543-02
106	Stk	Ignition Electrode and Cable	62-23556-01	62-23556-01

No.	Notes	MODEL TECHNICAL VARIATION COOLING CAPACITY ELECTRICAL DESIGNATION HEATING CAPACITY	RKKL-	RKKL-	RKKL-	RKKL-
			B 090/120 C 15	B 090/120 D 15	B 090/120 C/Y 22	B 090/120 D 22
HEAT EXCHANGER, BURNER / MANIFOLD						
98	Stk	Heat Exchanger	AS-90645-01	AS-90645-01	AS-90645-03	AS-90645-03
99		Inducer Mounting Plate Gasket	68-42518-02	68-42518-02	68-42518-02	68-42518-02
100		Turbulators	AE-58922-01 (6)	AE-58922-01 (6)	AE-58922-01 (9)	AE-58922-01 (9)
101		Inducer Mounting Plate	AE-90675-03	AE-90675-03	AE-90675-02	AE-90675-02
102		Inducer Blower Gasket (2)	68-23643-02	68-23643-02	68-23643-02	68-23643-02
103		Burner Support Brackets (2)	AE-90642-02	AE-90642-02	AE-90642-02	AE-90642-02
104		Burner Support	AE-90643-01	AE-90643-01	AE-90643-01	AE-90643-01
105	Stk	Spark Ignitor	62-23556-08	62-23556-08	62-23556-08	62-23556-08
106	Stk	Burner Assembly	AS-90772-01	AS-90772-01	AS-90772-02	AS-90772-02
107		Burner Orifices - Natural Gas	See Orifice Selection Chart			
107		Burner Orifices - LP	See Orifice Selection Chart			
107		Number of Orifices	(6)	(6)	(9)	(9)
108		Square Head Plug	81-23593-01 (4)	81-23593-01 (4)	81-23593-01 (1)	81-23593-01 (1)
109	Stk	Manifold	81-42509-03	81-42509-03	81-42509-02	81-42509-02
110		Gas Valve	See Gas Controls			
111		Street Elbow - 1/2 in. 90 degree	81-40271-04	81-40271-04	N/A	N/A
112	Stk	Flame Sensor	62-23543-02	62-23543-02	62-23543-02	62-23543-02
113a,b	Stk	Pressure Switch (2)	42-24335-25	42-24335-25	42-24335-23	42-24335-23
114		Pressure Switch Mounting Bracket (Single Mount)	AE-90635-05 (2)	AE-90635-05 (2)	AE-90635-05 (2)	AE-90635-05 (2)
115		Heat Shield	AE-90644-02	AE-90644-02	AE-90644-02	AE-90644-02
116	Stk	Limit - Manual Reset (Burner Compartment) (2)	47-22861-01	47-22861-01	47-22861-01	47-22861-01
117	Stk	Induced Draft Blower w/Gasket (2)	70-23641-01	70-23641-02	70-23641-01	70-23641-02
118		Flue Duct (2)	75-23678-01	75-23678-01	75-23678-01	75-23678-01
	Stk	Limit - Main Limit (Heat Exchanger Panel)	47-25349-09	47-25349-09	47-25349-02	47-25349-02

No.	Notes	MODEL TECHNICAL VARIATION COOLING CAPACITY ELECTRICAL DESIGNATION HEATING CAPACITY	RKKL-	RKKL-	RKKL-	RKKL-
			B 151 C 15	B 151 D 15	B 151 C,Y 25	B 151 D 25
HEAT EXCHANGER, BURNER / MANIFOLD						
98	Stk	Heat Exchanger	AS-90645-01	AS-90645-01	AS-90645-03	AS-90645-03
99		Inducer Mounting Plate Gasket	68-42518-02	68-42518-02	68-42518-02	68-42518-02
100		Turbulators	AE-58922-01 (6)	AE-58922-01 (6)	AE-58922-01 (9)	AE-58922-01 (9)
101		Inducer Mounting Plate	AE-90675-03	AE-90675-03	AE-90675-04	AE-90675-04
102		Inducer Blower Gasket (2)	68-23643-02	68-23643-02	68-23643-02	68-23643-02
103		Burner Support Brackets (2)	AE-90642-02	AE-90642-02	AE-90642-02	AE-90642-02
104		Burner Support	AE-90643-01	AE-90643-01	AE-90643-01	AE-90643-01
105	Stk	Spark Ignitor	62-23556-08	62-23556-08	62-23556-08	62-23556-08
106	Stk	Burner Assembly	AS-90772-01	AS-90772-01	AS-90772-02	AS-90772-02
107		Burner Orifices - Natural Gas	See Orifice Selection Chart			
107		Burner Orifices - LP	See Orifice Selection Chart			
107		Number of Orifices	(6)	(6)	(9)	(9)
108		Square Head Plug	81-23593-01 (4)	81-23593-01 (4)	81-23593-01 (1)	81-23593-01 (1)
109	Stk	Manifold	81-42509-03	81-42509-03	81-42509-02	81-42509-02
110		Gas Valve	See Gas Controls			
111		Street Elbow - 1/2 in. 90 degree	81-40271-04	81-40271-04	N/A	N/A
112	Stk	Flame Sensor	62-23543-02	62-23543-02	62-23543-02	62-23543-02
113a	Stk	Pressure Switch - Before F3311	42-24335-25	42-24335-25	42-24335-24 (See Note 3)	42-24335-24 (See Note 3)
113a	Stk	Pressure Switch - After F3311	42-24335-25	42-24335-25	42-24335-32	42-24335-32
113b	Stk	Pressure Switch	42-24335-25	42-24335-25	42-24335-23 (See Note 3)	42-24335-23 (See Note 3)
114		Pressure Switch Mounting Bracket (Single Mount)	AE-90635-05 (2)	AE-90635-05 (2)	AE-90635-05 (2)	AE-90635-05 (2)
115		Heat Shield	AE-90644-02	AE-90644-02	AE-90644-02	AE-90644-02
116	Stk	Limit - Manual Reset (Burner Compartment) (2)	47-22861-01	47-22861-01	47-22861-01	47-22861-01
117	Stk	Inducer Blower / Motor (2)	70-23641-01	70-23641-02	70-23641-01	70-23641-02
118		Flue Duct (2)	75-23678-01	75-23678-01	75-23678-01	75-23678-01
	Stk	Limit - Main Limit (Heat Exchanger Panel)	47-25349-09	47-25349-09	47-25349-04	47-25349-04

No.	Notes	MODEL TECHNICAL VARIATION COOLING CAPACITY ELECTRICAL DESIGNATION HEATING CAPACITY	RKKL-	RKKL-	RKKL-	RKKL-
			B 180 C 25	B 180 D 25	B 180 C,Y 35	B 180 D 35
HEAT EXCHANGER, BURNER / MANIFOLD						
98	Stk	Heat Exchanger	AS-90645-12	AS-90645-12	AS-90645-15	AS-90645-15
99		Inducer Mounting Plate Gasket	68-42518-03	68-42518-03	68-42518-03	68-42518-03
100		Turbulators	AE-58922-02 (10)	AE-58922-02 (10)	AE-58922-02 (14)	AE-58922-02 (14)
101		Inducer Mounting Plate	AE-90675-08	AE-90675-08	AE-90675-06	AE-90675-06
102		Inducer Blower Gasket	68-23643-02 (2)	68-23643-02 (2)	68-23643-02 (3)	68-23643-02 (3)
103		Burner Support Brackets (2)	AE-90642-02	AE-90642-02	AE-90642-02	AE-90642-02
104		Burner Support	AS-90830-01	AS-90830-01	AS-90830-01	AS-90830-01
105	Stk	Spark Ignitor	62-23556-10	62-23556-10	62-23556-10	62-23556-10
106	Stk	Burner Assembly	AS-90641-22	AS-90641-22	AS-90641-23	AS-90641-23
107		Burner Orifices - Natural Gas	See Orifice Selection Chart			
107		Burner Orifices - LP	See Orifice Selection Chart			
107		Number of Orifices	(10)	(10)	(14)	(14)
108		Square Head Plug	81-23593-01 (3)	81-23593-01 (3)	81-23593-01 (1)	81-23593-01 (1)
109	Stk	Manifold	81-42509-07	81-42509-07	81-42509-04	81-42509-04
110		Gas Valve	See Gas Controls			
111		Street Elbow - 3/4 in. 90 degree	81-40271-05	81-40271-05	81-40271-05	81-40271-05
		Nipple - 3/4 in. x 2-1/2 in.	81-40383-04	81-40383-04	81-40383-04	81-40383-04
		Standard Elbow - 3/4 in.	81-40394-05	81-40394-05	N/A	N/A
		Standard Elbow - 1 in. x 3/4 in. 90 degree	N/A	N/A	81-40394-24	81-40394-24
112	Stk	Flame Sensor	62-23543-02	62-23543-02	62-23543-02	62-23543-02
113A	Stk	Pressure Switch - High	42-24335-23 (1)	42-24335-23 (1)	42-24335-23 (1)	42-24335-23 (1)
113B	Stk	Pressure Switch - Low	42-24335-24 (1)	42-24335-24 (1)	42-24335-24 (2)	42-24335-24 (2)
114A		Pressure Switch Mounting Bracket (Single Mount)	AE-90635-05 (1)	AE-90635-05 (1)	AE-90635-05 (2)	AE-90635-05 (2)
114B		Pressure Switch Mounting Bracket (Dual Mount)	AE-90635-04	AE-90635-04	AE-90635-04	AE-90635-04
115		Heat Shield	AE-90644-03	AE-90644-03	AE-90644-03	AE-90644-03
116	Stk	Limit - Manual Reset (Burner Compartment) (4)	47-22861-01	47-22861-01	47-22861-01	47-22861-01
117	Stk	Induced Draft Blower w/Gasket	70-23641-01 (2)	70-23641-02 (2)	70-23641-01 (3)	70-23641-02 (3)
118		Flue Duct	75-23678-01 (2)	75-23678-01 (2)	75-23678-01 (3)	75-23678-01 (3)
		Gasket - Flue Duct	68-23680-04 (4)	68-23680-04 (4)	68-23680-04 (6)	68-23680-04 (6)
	Stk	Limit - Main Limit (Heat Exchanger Panel)	47-25349-09	47-25349-09	47-25349-03	47-25349-03

No.	Notes	MODEL TECHNICAL VARIATION COOLING CAPACITY ELECTRICAL DESIGNATION HEATING CAPACITY	RKKL- B 240 C 30	RKKL- B 240 D 30	RKKL- B 240 C,Y 40	RKKL- B 240 D 40
HEAT EXCHANGER, BURNER / MANIFOLD						
98	Stk	Heat Exchanger	AS-90645-16	AS-90645-16	AS-90645-15	AS-90645-15
99		Inducer Mounting Plate Gasket	68-42518-03	68-42518-03	68-42518-03	68-42518-03
100		Turbulators	AE-58922-02 (12)	AE-58922-02 (12)	AE-58922-02 (14)	AE-58922-02 (14)
101		Inducer Mounting Plate	AE-90675-07	AE-90675-07	AE-90675-05	AE-90675-05
102		Inducer Blower Gasket	68-23643-02 (3)	68-23643-02 (3)	68-23643-02 (4)	68-23643-02 (4)
103		Burner Support Brackets (2)	AE-90642-02	AE-90642-02	AE-90642-02	AE-90642-02
104		Burner Support	AS-90830-01	AS-90830-01	AS-90830-01	AS-90830-01
105	Stk	Spark Ignitor	62-23556-10	62-23556-10	62-23556-10	62-23556-10
106	Stk	Burner Assembly	AS-90641-24	AS-90641-24	AS-90641-18	AS-90641-18
107		Burner Orifices - Natural Gas	See Orifice Selection Chart			
107		Burner Orifices - LP	See Orifice Selection Chart			
107		Number of Orifices	(12)	(12)	(14)	(14)
108		Square Head Plug	81-23593-01 (1)	81-23593-01 (1)	81-23593-01 (1)	81-23593-01 (1)
109	Stk	Manifold	81-42509-07	81-42509-07	81-42509-04	81-42509-04
110		Gas Valve	See Gas Controls			
111		Street Elbow - 3/4 in. 90 degree	81-40271-05	81-40271-05	81-40271-05	81-40271-05
		Nipple - 3/4 in. x 2-1/2 in.	81-40383-04	81-40383-04	81-40383-04	81-40383-04
		Standard Elbow - 3/4 in.	81-40394-05	81-40394-05	N/A	N/A
		Standard Elbow - 1 in. x 3/4 in. 90 degree	N/A	N/A	81-40394-24	81-40394-24
112	Stk	Flame Sensor	62-23543-02	62-23543-02	62-23543-02	62-23543-02
113A	Stk	Pressure Switch - High	42-24335-21 (1)	42-24335-21 (1)	42-24335-23 (2)	42-24335-23 (2)
113B	Stk	Pressure Switch - Low	42-24335-24 (2)	42-24335-24 (2)	42-24335-24 (2)	42-24335-24 (2)
114A		Pressure Switch Mounting Bracket (Single Mount)	AE-90635-05 (2)	AE-90635-05 (2)	AE-90635-05 (2)	AE-90635-05 (2)
114B		Pressure Switch Mounting Bracket (Dual Mount)	AE-90635-04	AE-90635-04	AE-90635-04	AE-90635-04
115		Heat Shield	AE-90644-03	AE-90644-03	AE-90644-03	AE-90644-03
116	Stk	Limit - Manual Reset (Burner Compartment) (4)	47-22861-01	47-22861-01	47-22861-01	47-22861-01
117	Stk	Induced Draft Blower w/Gasket	70-23641-01 (3)	70-23641-02 (3)	70-23641-01 (4)	70-23641-02 (4)
118		Flue Duct (2)	75-23678-01 (3)	75-23678-01 (3)	75-23678-01 (4)	75-23678-01 (4)
		Gasket - Flue Duct	68-23680-04 (6)	68-23680-04 (6)	68-23680-04 (8)	68-23680-04 (8)
	Stk	Limit - Main Limit (Heat Exchanger Panel)	47-25349-14	47-25349-14	47-25349-14	47-25349-14

No.	Notes	MODEL GAS CODE	RKKL- 2G	RKKL- 1R	RKKL- 2A	RKKL- 1X
GAS CONTROLS						
107	Stk	Gas Valve - Natural Gas	60-100394-02	60-22447-07	60-23490-01	60-23490-01
107	Stk	Gas Valve - LP	See Note 2	See Note 2	See Note 2	See Note 2
	Stk	Integrated Furnace Control Board (IFC)	62-23599-03	62-23599-03	62-23599-03	62-23599-03
108		Street Elbow	81-17487-01	81-17487-01	81-40271-04	81-40271-04
		Nipple	81-40683-02	81-40683-02	N/A	N/A
	Stk	LP Conversion Kit	EP-85H	EP-85H	EP-84W	EP-84W

No.	Notes	MODEL GAS CODE	RKKL- 2L	RKKL- 2M	RKKL- 2N	
GAS CONTROLS						
110	Stk	Gas Valve - Natural Gas	60-101778-01	60-101778-01	60-102405-01	
110	Stk	Gas Valve - LP	See Note 2	See Note 2	See Note 1	
	Stk	Integrated Furnace Control Board (IFC)	62-102860-01	62-102860-01	62-102860-01	
111		Street Elbow	See Heat Exchanger Group			
	Stk	LP Conversion Kit	FP-14	FP-14	FP-24	

No.	Notes	MODEL TECHNICAL VARIATION COOLING CAPACITY	RKKL- B 072
OPTIONS AND ACCESSORIES			
		Louver Panel Kit (Neutra Green)	RXRZ-AAD01B
		Louver Panel Kit (Granite/Steel Gray)	AXRX-AAD01B
		Low Ambient Control Kit	RXRZ-A85
		Compressor Time Delay	RXMD-B04
		Economizer - Single Enthalpy	RXRD-MCCM3
		Dual Enthalpy Upgrade Kit	RXRZ-AV02
		Carbon Dioxide Sensor	RXRZ-AR02
		Power Exhaust - "C" Voltage (Neutra Green)	RXRZ-BGF03C
		Power Exhaust - "C" Voltage (Granite/Steel Gray)	AXRX-BGF03C
		Power Exhaust - "D" Voltage (Neutra Green)	RXRZ-BGF03D
		Power Exhaust - "D" Voltage (Granite/Steel Gray)	AXRX-BGF03D
		Power Exhaust - "Y" Voltage (Neutra Green)	RXRZ-BGF03Y
		Power Exhaust - "Y" Voltage (Granite/Steel Gray)	AXRX-BGF03Y
		Fresh Air Damper - Manual (Neutra Green)	RXRF-FCA1
		Fresh Air Damper - Manual (Granite/Steel Gray)	AXRF-FCA1
		Fresh Air Damper - Motorized (Neutra Green)	RXRF-FCB1
		Fresh Air Damper - Motorized (Granite/Steel Gray)	AXRF-FCB1
		Fresh Air Damper - Motorized (Smoke Detector Compatible) (Neutra Green)	RXRF-JHB1
		Fresh Air Damper - Motorized (Smoke Detector Compatible) (Granite/Steel Gray)	AXRF-JHB1

No.	Notes	MODEL TECHNICAL VARIATION COOLING CAPACITY	RKKL- B 090-151
ACCESSORIES			
		Louver Panel - Option (7.5 - 10 Ton) (Neutra Green)	RXRZ-AAD02A
		Louver Panel - Option (7.5 - 10 Ton) (Granite/Steel Gray)	AXRX-AAD02A
		Carbon Dioxide Sensor	RXRZ-AR02
		Dual Enthalpy Kit	RXRZ-AV02
		Manual Fresh Air (Left Panel Mounted) (Neutra Green)	RXRF-KDA1
		Manual Fresh Air (Left Panel Mounted) (Granite/Steel Gray)	AXRF-KDA1
		Motor Kit for RXRF-KDA1/AXRF-KDA1	RXRZ-AW02
		Manual Fresh Air (Return Panel) (Neutra Green)	RXRF-JDA1
		Manual Fresh Air (Return Panel) (Granite/Steel Gray)	AXRF-JDA1
		Motorized Fresh Air (Return Panel) (Neutra Green)	RXRF-JDB1
		Motorized Fresh Air (Return Panel) (Granite/Steel Gray)	AXRF-JDB1
		Time Delay Relay - Option	RXMD-A04
		Freeze Stat - Option	RXRZ-AM01
		Convenience Outlet - Option	RXRZ-AN01
		Low Ambient Control Kit (One per Compressor)	RXRZ-C02

No.	Notes	MODEL TECHNICAL VARIATION COOLING CAPACITY	RKKL- B 090-151
ECONOMIZERS			
		Economizer - Single Enthalpy (Neutra Green)	RXRD-PDCM3
		Economizer - Single Enthalpy (Granite/Steel Gray)	AXRD-PDCM3
		Economizer - Single Enthalpy w/Smoke Detector (Neutra Green)	RXRD-SDCM3
		Economizer - Single Enthalpy w/Smoke Detector (Granite/Steel Gray)	AXRD-SDCM3
		Horizontal Economizer - Single Enthalpy (Neutra Green)	RXRD-RDCM3
		Horizontal Economizer - Single Enthalpy (Granite/Steel Gray)	AXRD-RDCM3

No.	Notes	MODEL TECHNICAL VARIATION COOLING CAPACITY	RKKL- B 090-151
POWER EXHAUST			
		Power Exhaust	RXRZ-BFF02C
		Power Exhaust	RXRZ-BFF02D
		Power Exhaust	RXRZ-BFF02Y

No.	Notes	MODEL TECHNICAL VARIATION COOLING CAPACITY	RKKL- B 180-240
ACCESSORIES			
		Louver Panel Assembly (Neutra Green)	RXXR-AAD01K
		Louver Panel Assembly (Granite/Steel Gray)	AXRX-AAD01K
		Carbon Dioxide Sensor	RXXR-AR02
		Dual Enthalpy Kit	RXXR-AV02
		Compressor Time Delay Relay Kit	RXMD-A04
		Manual Fresh Air Damper (Neutra Green)	RXRF-KFA1
		Manual Fresh Air Damper (Granite/Steel Gray)	AXRF-KFA1
		Motorized Kit for RXRF-KFA1/AXRF-KFA1	RXXR-AW03
		Freeze Stat Kit	RXXR-AM03
		Unwired Convenience Outlet	RXXR-AN01
		Unfused Service Disconnect	RXXR-AP01
		Low Ambient Control Kit (One per Compressor)	RXXR-C02

No.	Notes	MODEL TECHNICAL VARIATION COOLING CAPACITY	RKKL- B 180-240
ECONOMIZERS			
		Downflow Economizer - Single Enthalpy (Neutra Green)	RXRD-PGCM3
		Downflow Economizer - Single Enthalpy (Granite/Steel Gray)	AXRD-PGCM3
		Downfloe Economizer - Single Enthalpy w/Smoke Detector (Neutra Green)	RXRD-SGCM3
		Downfloe Economizer - Single Enthalpy w/Smoke Detector (Granite/Steel Gray)	AXRD-SGCM3
		Horizontal Economizer - Single Enthalpy (Neutra Green)	RXRD-RGCM3
		Horizontal Economizer - Single Enthalpy (Granite/Steel Gray)	AXRD-RGCM3

No.	Notes	MODEL TECHNICAL VARIATION COOLING CAPACITY	RKKL- B 180-240
POWER EXHAUST			
		Power Exhaust	RXXR-BGF05C
		Power Exhaust	RXXR-BGF05D
		Power Exhaust	RXXR-BGF05Y

PACKAGE EQUIPMENT - ORIFICE SELECTION CHART - NATURAL GAS

CAUTION: Selection of the correct Natural Gas Orifice requires the following information for the specific installation:

- 1) Furnace Input Rating (BTU/HR)
- 2) Number of Burners
- 2) Altitude (ft.)

For detailed information and instructions for Orifice selection, see the Gas Furnace LP Conversion Kit Index 92-21519-47 and the latest edition of the National Fuel Gas Code Handbook, or the National Standard of Canada, Natural Gas and Propane Installation Code, CAN B149.1.

CAUTION: This information is provided for replacement purposes only. Conversion for operation at High Altitude must be done using the kit specified on the product specification sheet for the unit.

NOTE: This Orifice sizing chart is based on a Natural Gas heating value of 1075 BTU/cu. ft and a pressure setting of 3.5 in. water column.

NOTE: Factory installed orifices are calculated and sized based on a Natural Gas heating value of 1075 BTU/cu. ft. and an elevation of 0 - 2000 ft.

Furnace Input Rating (BTU/HR)	Canadian High Altitude Derated Input (BTU/HR)	Number of Burners	Elevation (ft.)					
			Country					
			0 - 2000 U.S.	2001 - 4000 U.S.	4001 - 6000 U.S.	8000+ U.S.	0 - 2000 Canada	2001 - 4500 Canada
40,000	36,000	2	62-22175-45	62-22175-47	62-22175-48	62-22175-49	62-22175-45	62-22175-15
60,000	54,000	3	62-22175-45	62-22175-47	62-22175-48	62-22175-49	62-22175-45	62-22175-15
72,000	N/A	4	62-22175-15	62-22175-49	62-22175-50	62-22175-51	62-22175-15	N/A
80,000	72,000	4	62-22175-45	62-22175-47	62-22175-48	62-22175-49	62-22175-45	62-22175-15
90,000	N/A	5	62-22175-15	62-22175-49	62-22175-50	62-22175-51	62-22175-15	N/A
100,000	90,000	5	62-22175-45	62-22175-47	62-22175-48	62-22175-49	62-22175-45	62-22175-15
120,000	108,000	6	62-22175-45	62-22175-47	62-22175-48	62-22175-49	62-22175-45	62-22175-15
135,000	121,500	6	62-22175-44	62-22175-45	62-22175-47	62-22175-48	62-22175-44	62-22175-45
150,000	135,000	6	62-22175-42	62-22175-43	62-22175-44	62-22175-45	62-22175-42	62-22175-44
180,000	N/A	9	62-22175-45	62-22175-47	62-22175-48	62-22175-49	62-22175-45	N/A
210,000	N/A	9	62-22175-43	62-22175-44	62-22175-45	62-22175-47	62-22175-43	N/A
210,000	N/A	10	62-22175-45	62-22175-47	62-22175-48	62-22175-49	62-22175-45	N/A
225,000	202,500	9	62-22175-42	62-22175-43	62-22175-44	62-22175-45	62-22175-42	62-22175-44
250,000	225,000	10	62-22175-42	62-22175-43	62-22175-44	62-22175-45	62-22175-42	62-22175-44
252,000	225,000	9	62-22175-40	62-22175-42	62-22175-43	62-22175-44	62-22175-40	62-22175-42
252,000	N/A	12	62-22175-45	62-22175-47	62-22175-48	62-22175-49	62-22175-45	N/A
290,000	N/A	14	62-22175-45	62-22175-47	62-22175-48	62-22175-49	62-22175-45	N/A
300,000	270,000	12	62-22175-42	62-22175-43	62-22175-44	62-22175-45	62-22175-42	62-22175-44
330,000	N/A	14	62-22175-43	62-22175-44	62-22175-45	62-22175-47	62-22175-43	N/A
350,000	315,000	14	62-22175-42	62-22175-43	62-22175-44	62-22175-45	62-22175-42	62-22175-44
400,000	360,000	14	62-22175-40	62-22175-42	62-22175-43	62-22175-44	62-22175-40	62-22175-42

PACKAGE EQUIPMENT - ORIFICE SELECTION CHART - LP

CAUTION: Selection of the correct LP Orifice requires the following information for the specific installation:

- 1) Furnace Input Rating (BTU/HR)
- 2) Number of Burners
- 2) Altitude (ft.)

For detailed information and instructions for Orifice selection, see the Gas Furnace LP Conversion Kit Index 92-21519-47 and the latest edition of the National Fuel Gas Code Handbook, or the National Standard of Canada, Natural Gas and Propane Installation Code, CAN B149.1.

CAUTION: This information is provided for replacement purposes only. Conversion to LP or for operation at High Altitude should be done using the kit(s) specified on the product specification sheet for the unit.

NOTE: This Orifice sizing chart is developed using the specified pressure setting of 10 in. water column instead of the 11.0 in water column used by the NFG and CANB149.1.

NOTE: Orifices supplied in the LP Conversion Kit are calculated and sized based on a heating value of 2500 BTU/cu. ft. and an elevation of 0 - 2000 ft.

Furnace Input Rating (BTU/HR)	Canadian High Altitude Derated Input (BTU/HR)	Number of Burners	Elevation (ft.)					
			Country					
			0 - 2000 U.S.	2001 - 4000 U.S.	4001 - 6000 U.S.	8000+ U.S.	0 - 2000 Canada	2001 - 4500 Canada
40,000	36,000	2	62-22175-55	62-22175-55	62-22175-56	62-22175-56	62-22175-55	62-22175-13
60,000	54,000	3	62-22175-55	62-22175-55	62-22175-56	62-22175-56	62-22175-55	62-22175-13
72,000	N/A	4	62-22175-13	62-22175-57	62-22175-57	62-22175-59	62-22175-13	N/A
80,000	72,000	4	62-22175-55	62-22175-55	62-22175-56	62-22175-56	62-22175-55	62-22175-13
90,000	N/A	5	62-22175-13	62-22175-57	62-22175-57	62-22175-59	62-22175-13	N/A
100,000	90,000	5	62-22175-55	62-22175-55	62-22175-56	62-22175-56	62-22175-55	62-22175-13
120,000	108,000	6	62-22175-55	62-22175-55	62-22175-56	62-22175-56	62-22175-55	62-22175-13
135,000	121,500	6	62-22175-54	62-22175-55	62-22175-55	62-22175-56	62-22175-54	62-22175-55
150,000	135,000	6	62-22175-54	62-22175-55	62-22175-55	62-22175-56	62-22175-54	62-22175-54
180,000	N/A	9	62-22175-55	62-22175-55	62-22175-56	62-22175-56	62-22175-55	N/A
210,000	N/A	9	62-22175-54	62-22175-55	62-22175-55	62-22175-56	62-22175-54	N/A
210,000	N/A	10	62-22175-55	62-22175-55	62-22175-56	62-22175-56	62-22175-55	N/A
225,000	202,500	9	62-22175-54	62-22175-55	62-22175-55	62-22175-56	62-22175-54	62-22175-54
250,000	225,000	10	62-22175-54	62-22175-55	62-22175-55	62-22175-56	62-22175-54	62-22175-54
252,000	225,000	9	62-22175-53	62-22175-54	62-22175-54	62-22175-55	62-22175-53	62-22175-54
252,000	N/A	12	62-22175-55	62-22175-55	62-22175-56	62-22175-56	62-22175-55	N/A
290,000	N/A	14	62-22175-55	62-22175-55	62-22175-56	62-22175-56	62-22175-55	N/A
300,000	270,000	12	62-22175-54	62-22175-55	62-22175-55	62-22175-56	62-22175-54	62-22175-54
330,000	N/A	14	62-22175-54	62-22175-55	62-22175-55	62-22175-56	62-22175-54	N/A
350,000	315,000	14	62-22175-54	62-22175-55	62-22175-55	62-22175-56	62-22175-54	62-22175-54
400,000	360,000	14	62-22175-53	62-22175-54	62-22175-54	62-22175-55	62-22175-53	62-22175-54

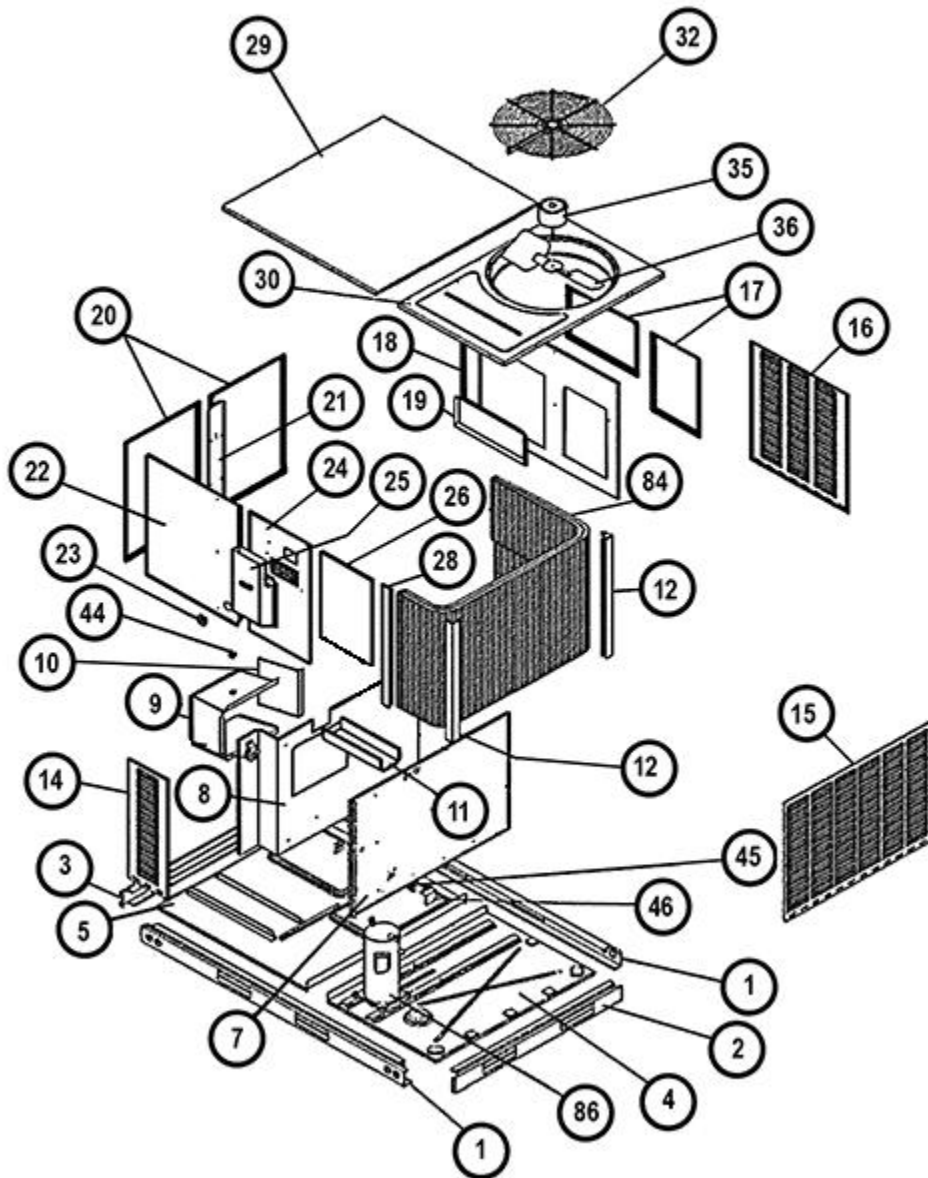

Exploded View 072

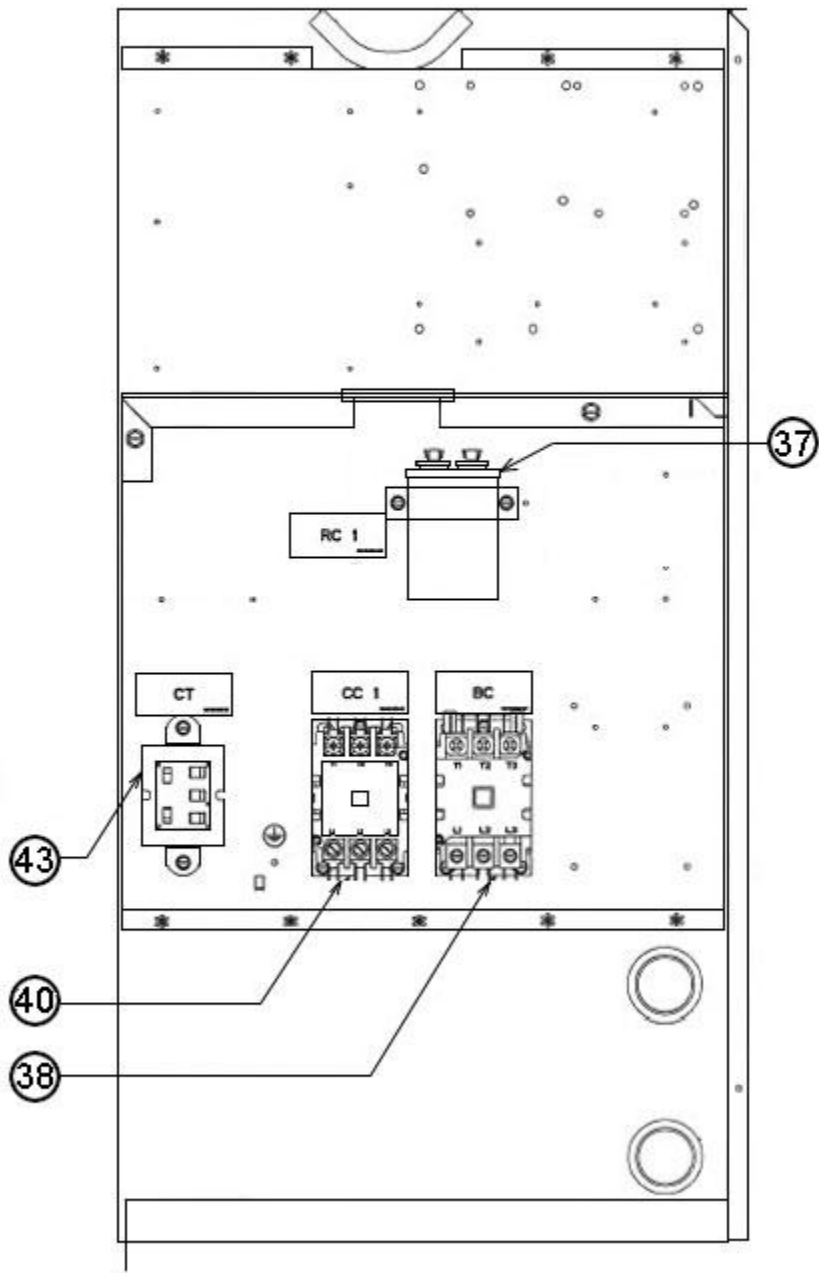

Control Box 072

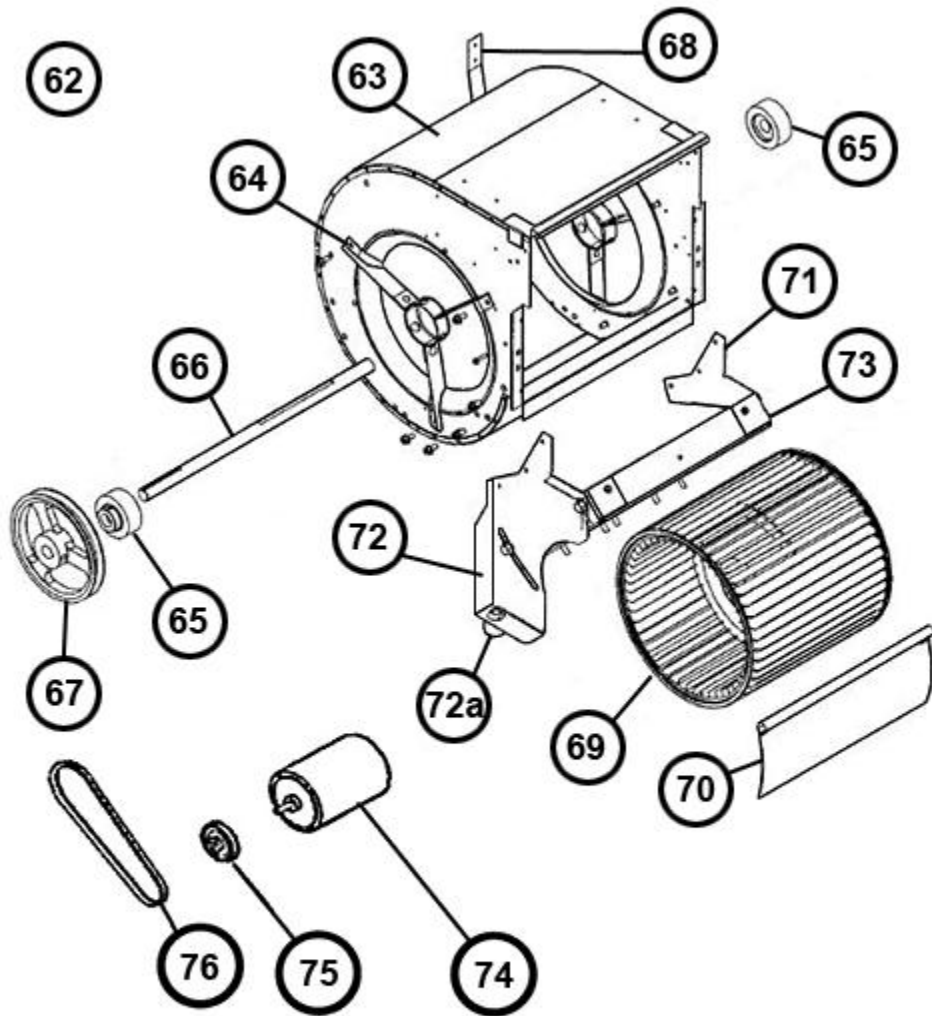

Blower Assembly - Belt Drive 072

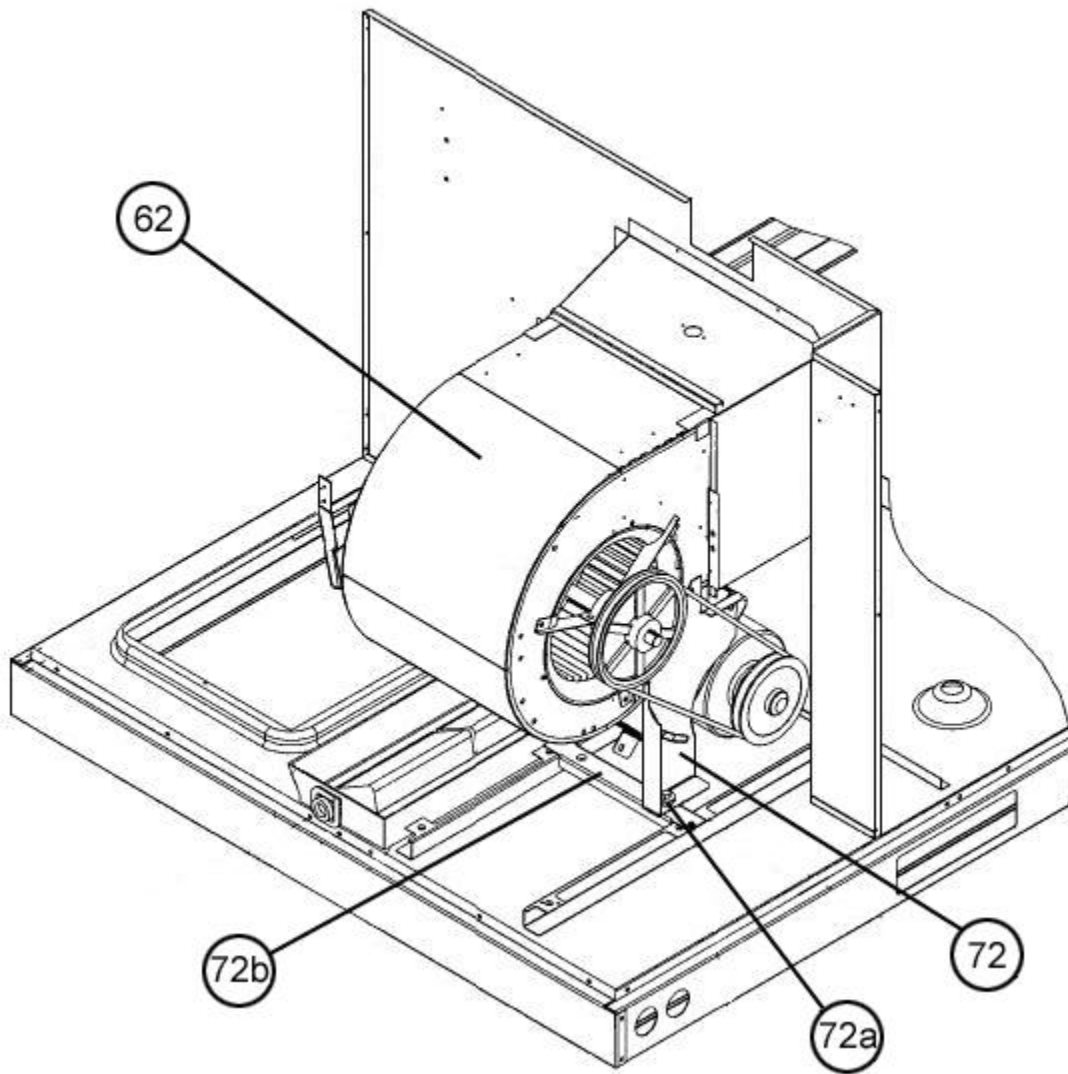

Blower Motor Mount Assembly - Belt Drive 072

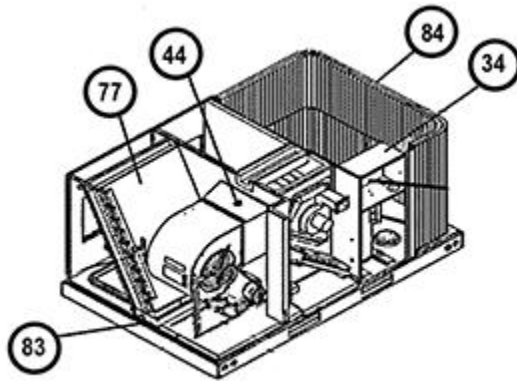

Coil Group Cut-away View 072

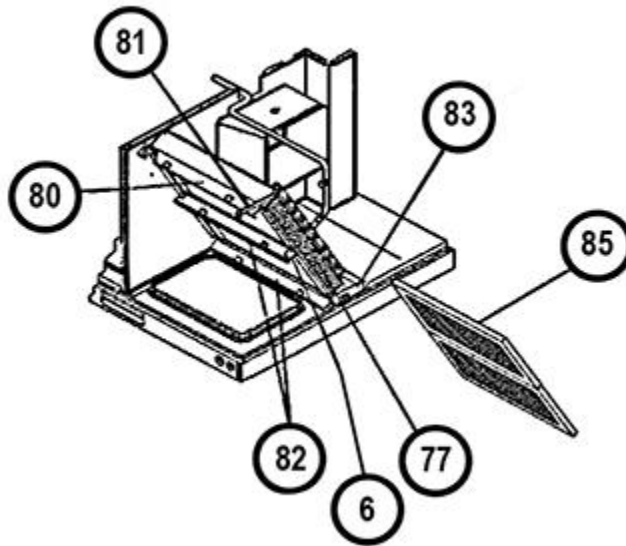

Evaporator Coil - Filter Parts 072

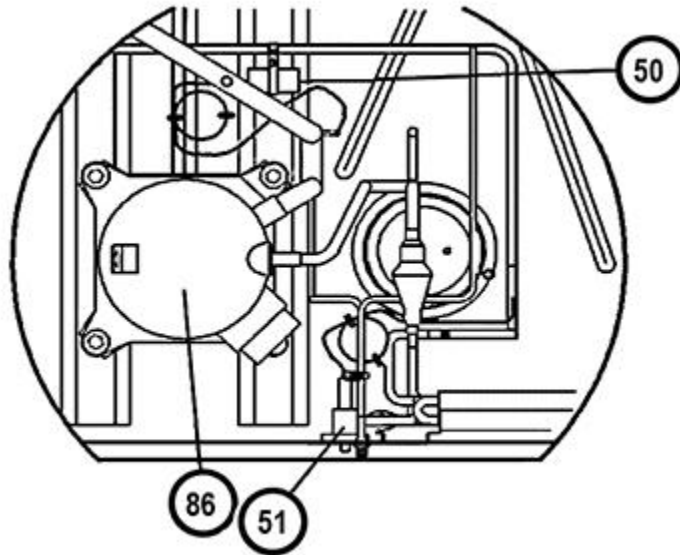

Compressor - Refrigeration Group 072

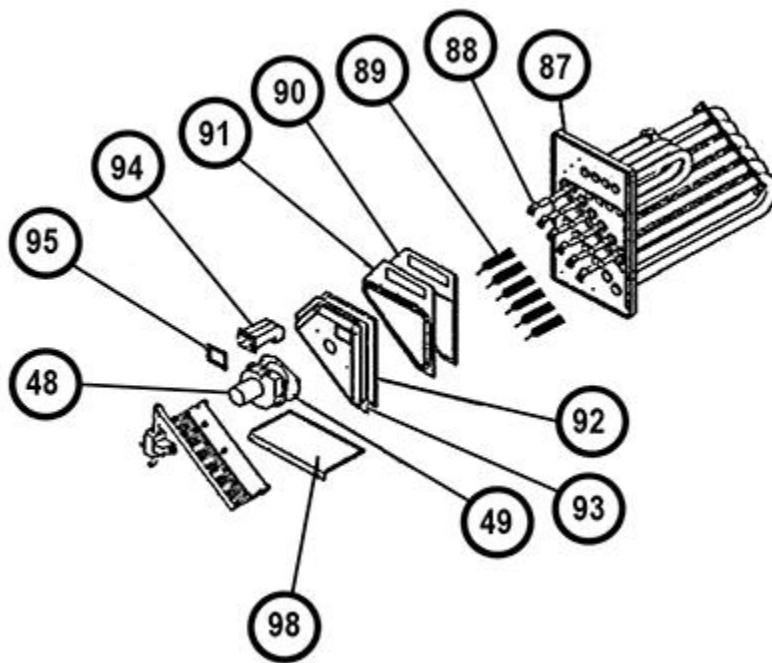

Heat Exchanger Assembly 072

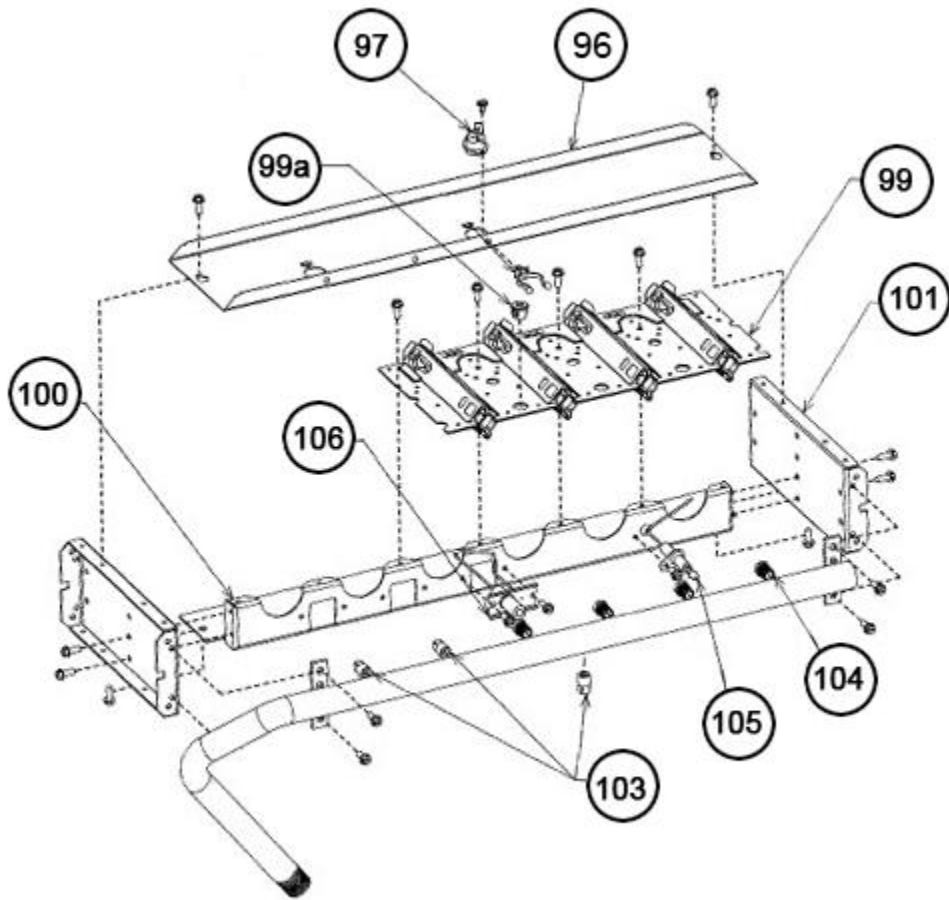

One Piece Burner Assembly 072

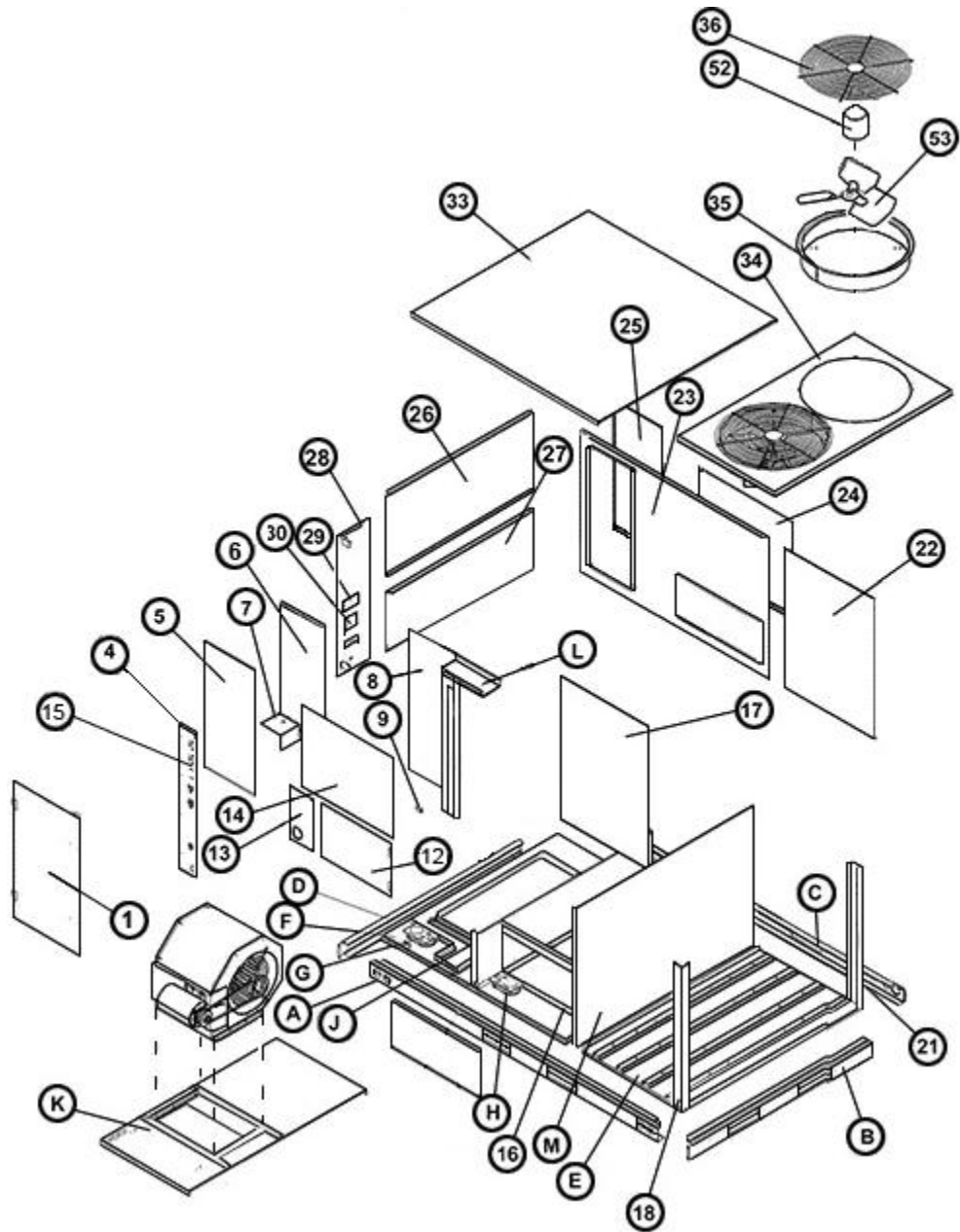

Exploded View 090-151

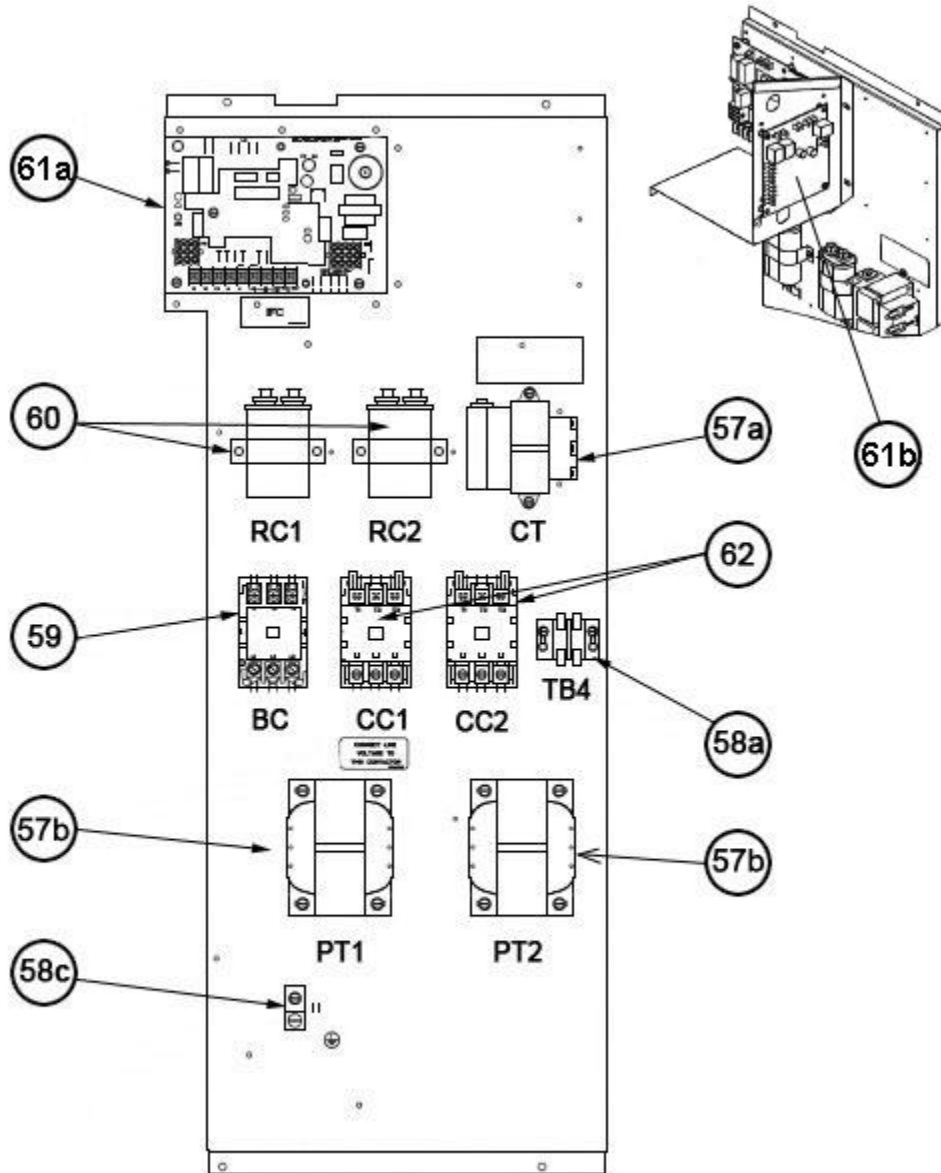

Control Box 090-151

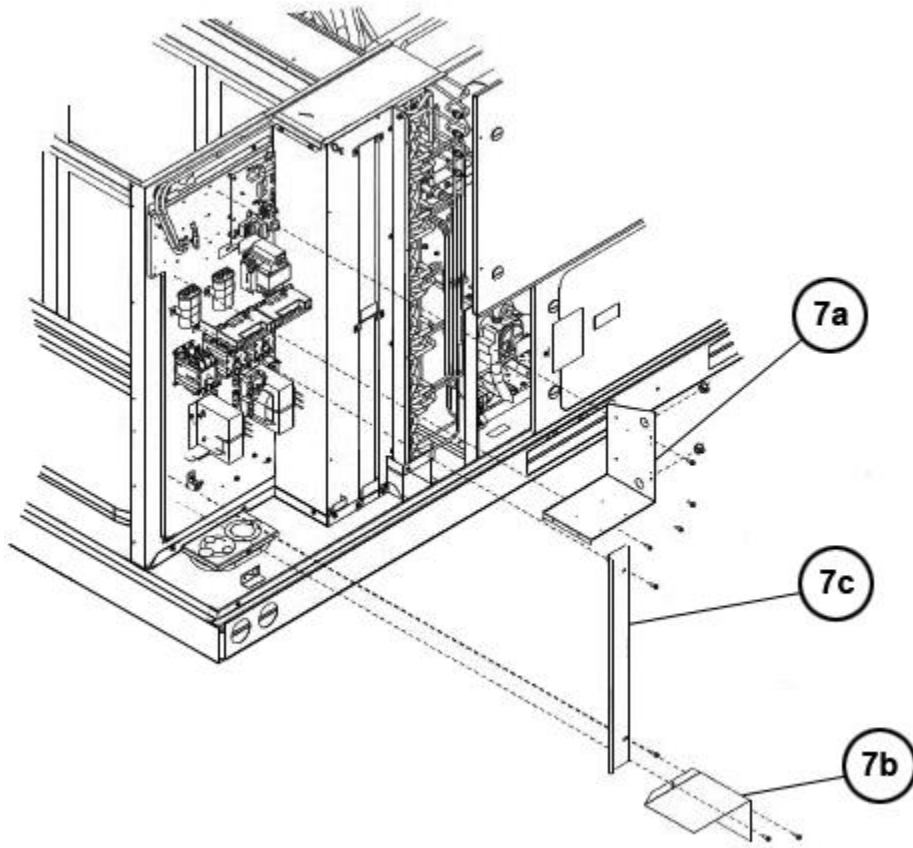

Low Voltage Shields 090-151

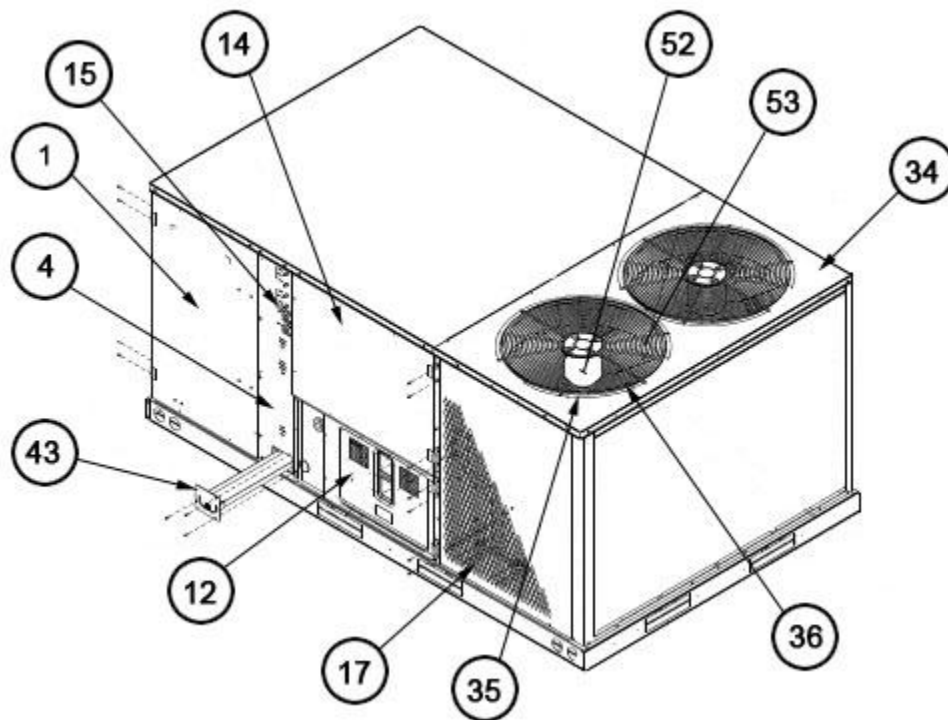

Exterior - Front 090-151

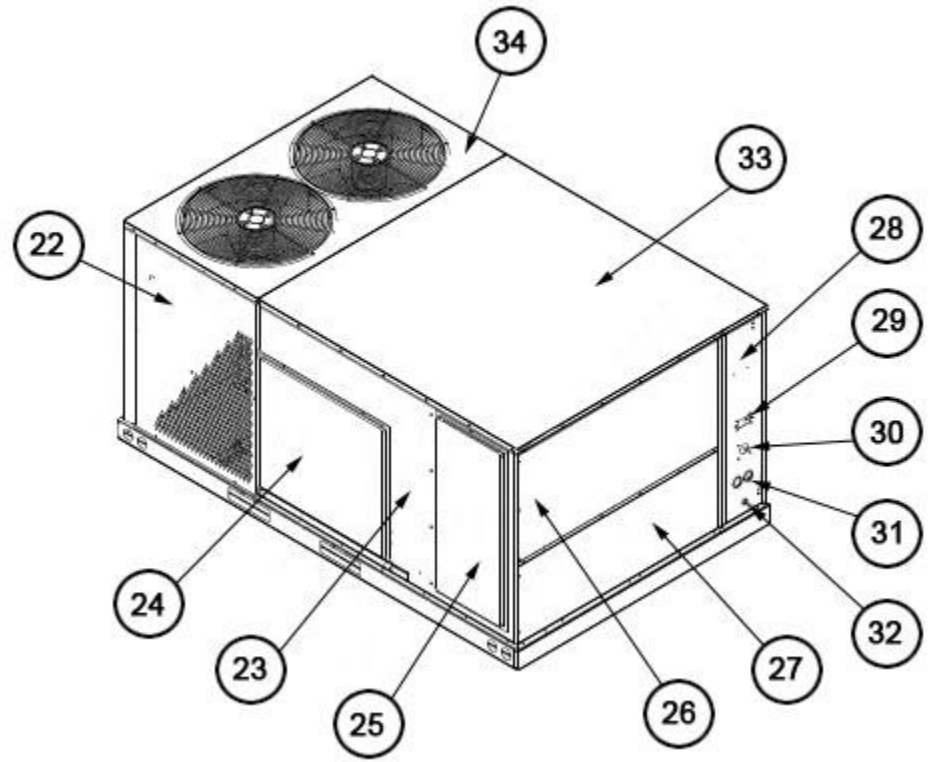

Exterior - Back 090-151

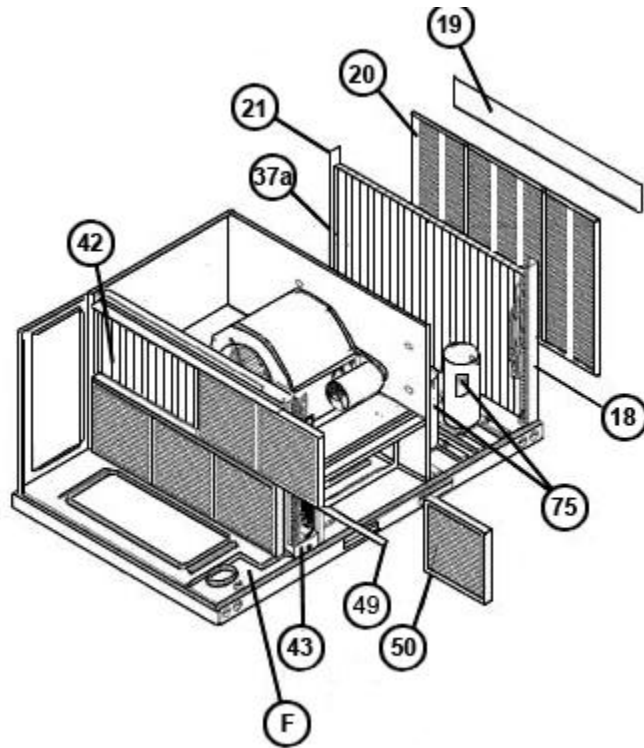

Filter-Coil Assembly 090-151

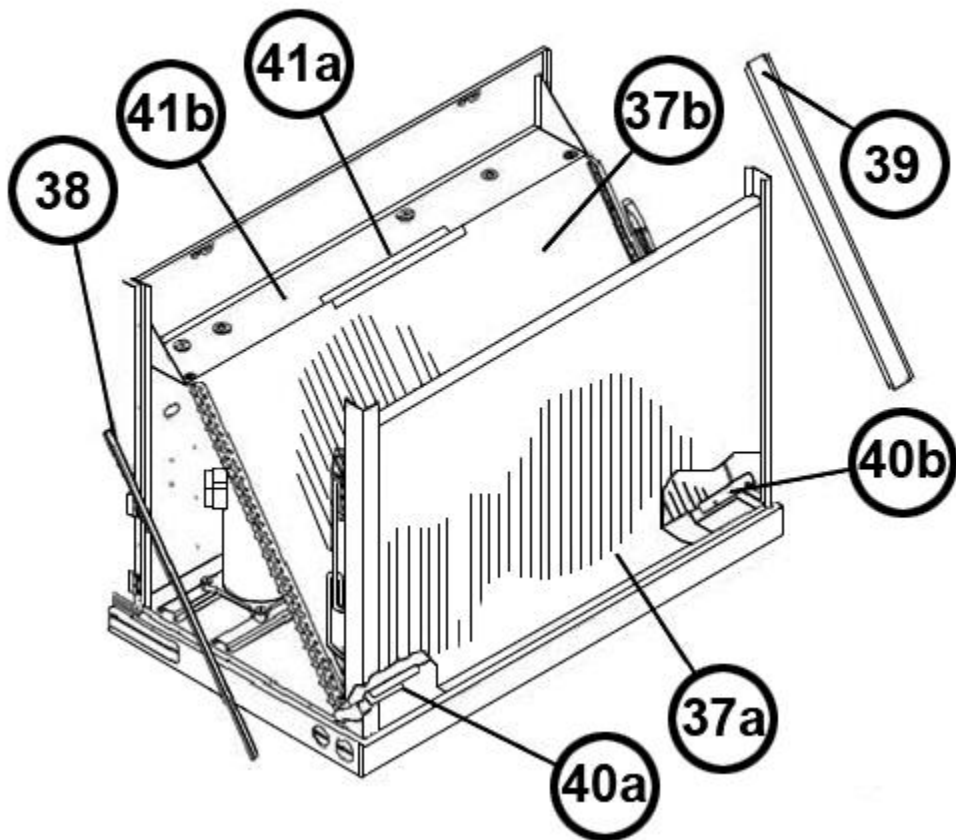

Condenser Coil Assembly 090-151

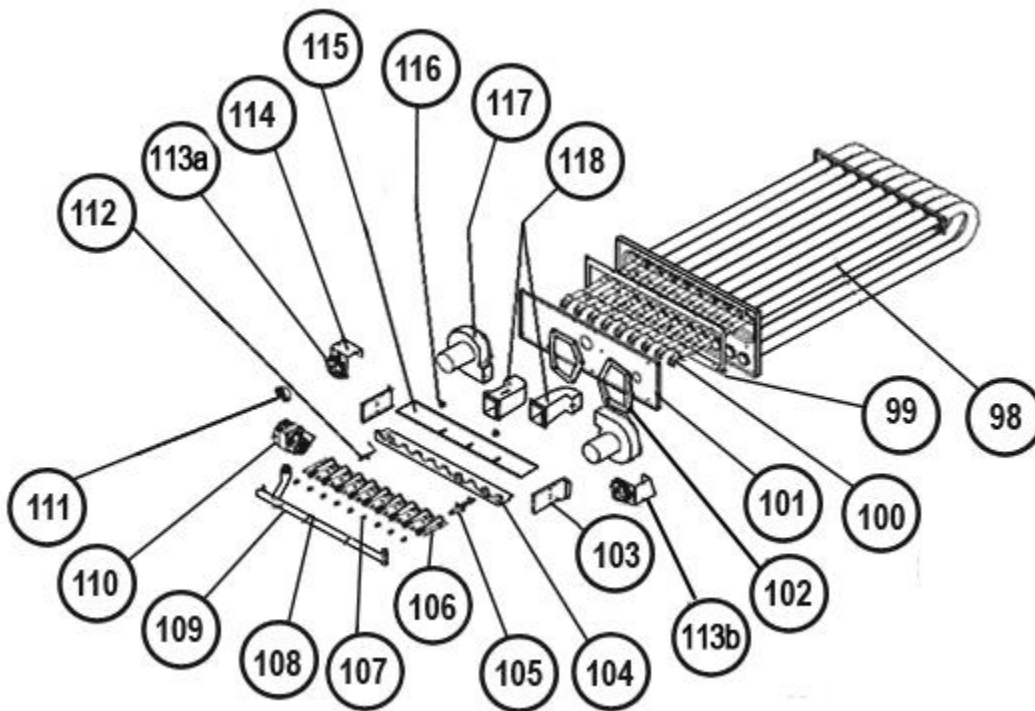

Heat Exchanger Assembly 090-151

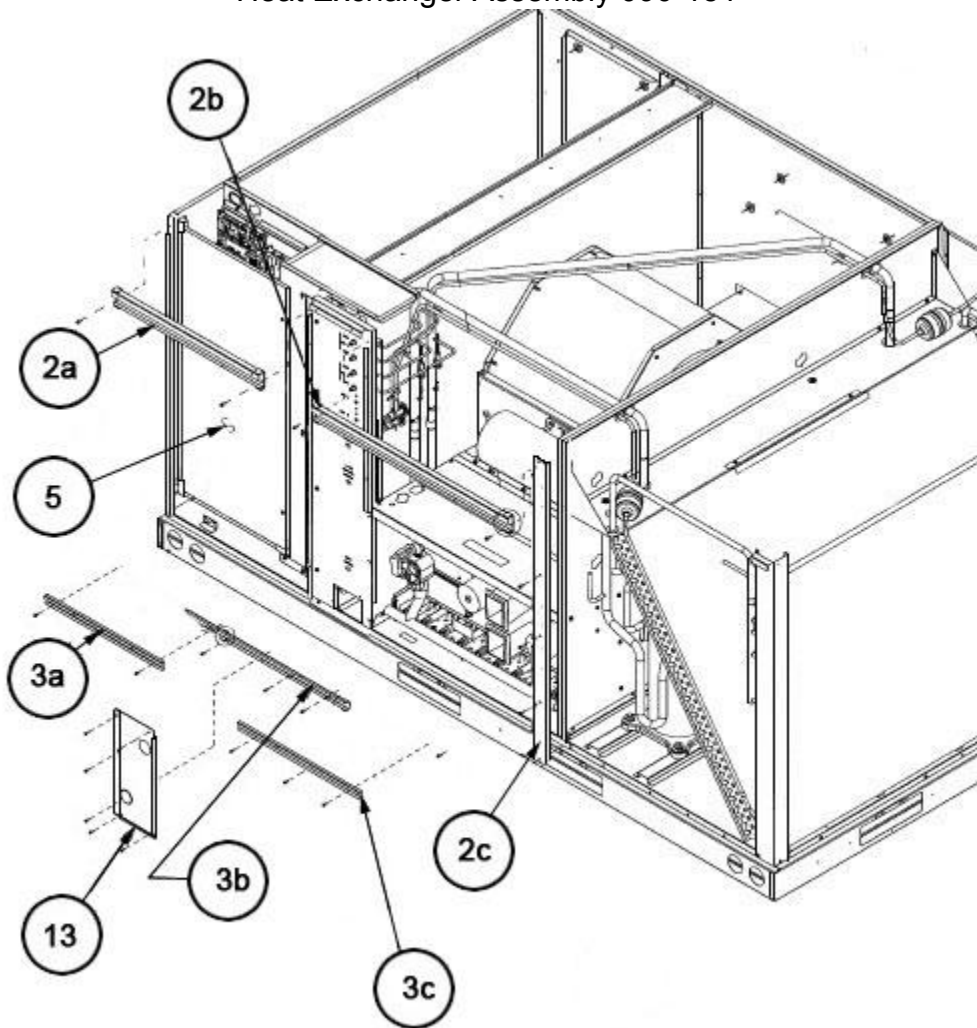

Front Panel Brackets 090-151

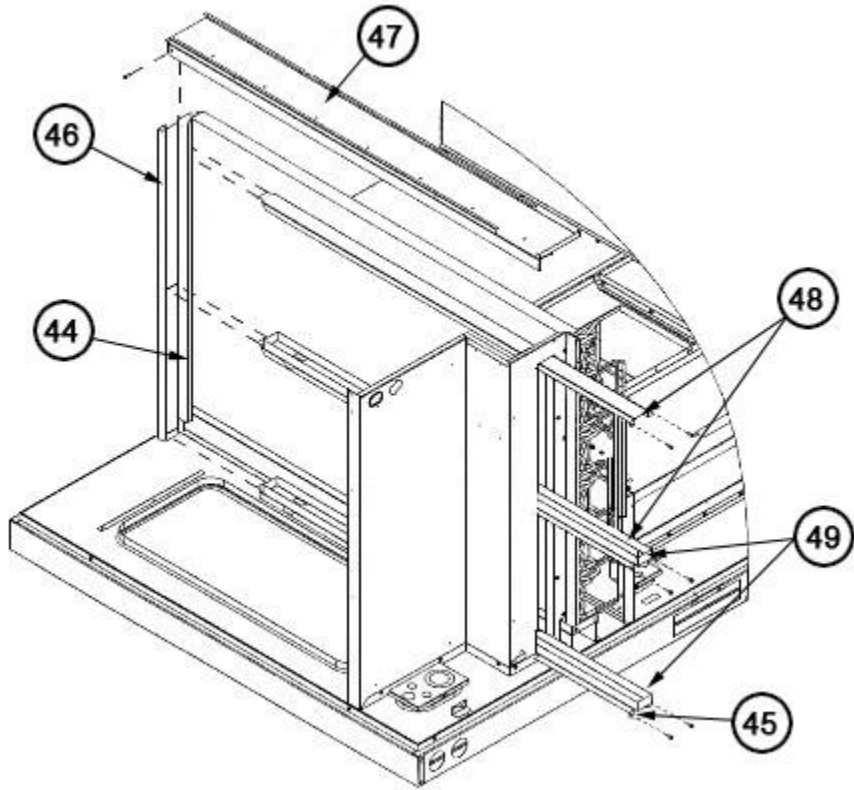

Filter Frame Assembly 090-151

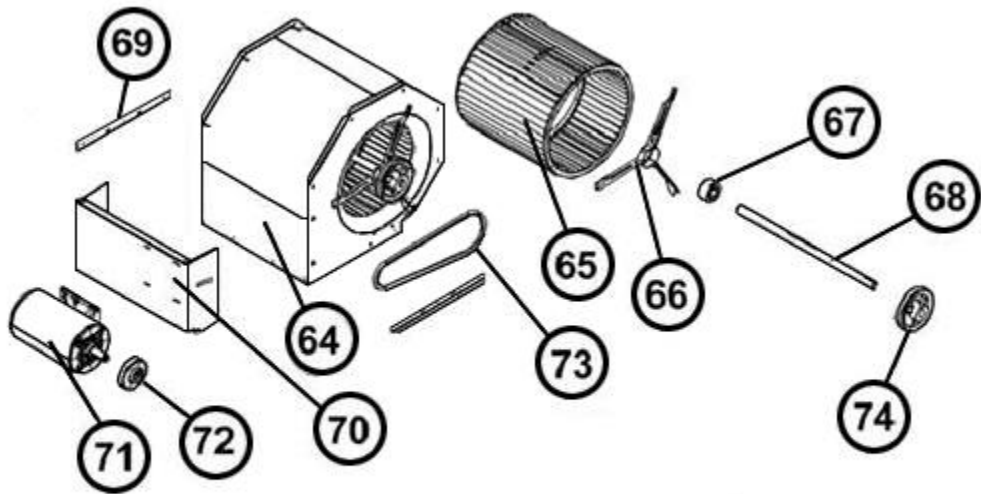

Blower Assembly 090-151

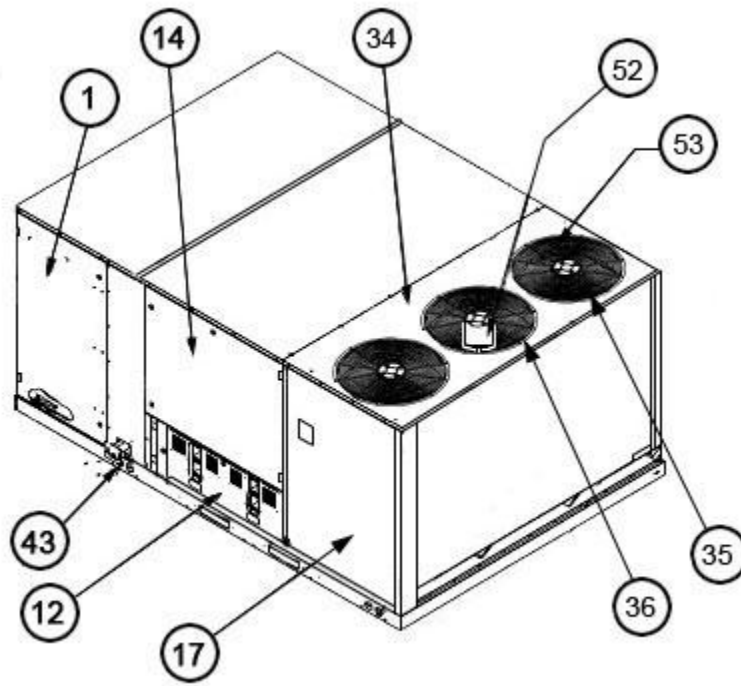

Exterior - Front 180

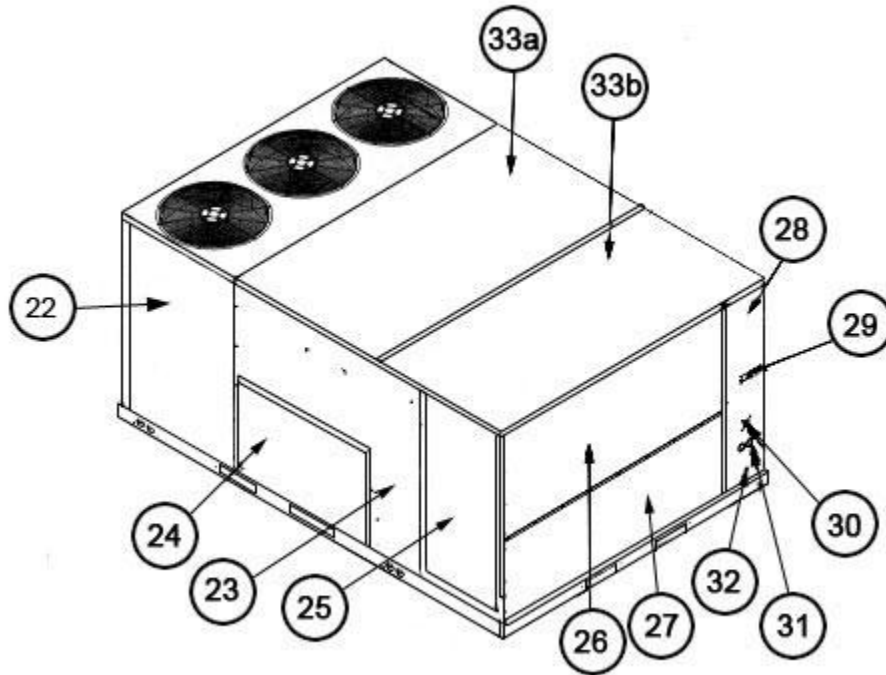

Exterior - Back 180

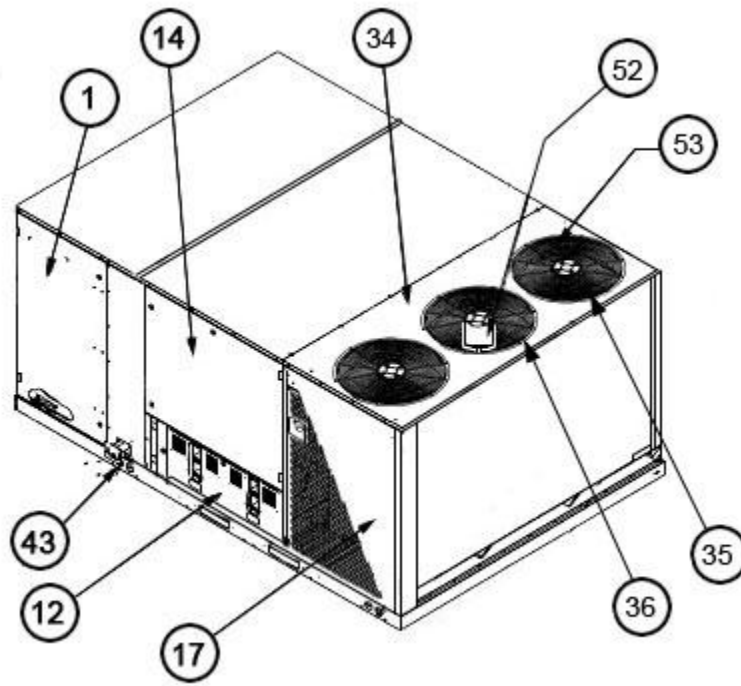

Exterior - Front 240

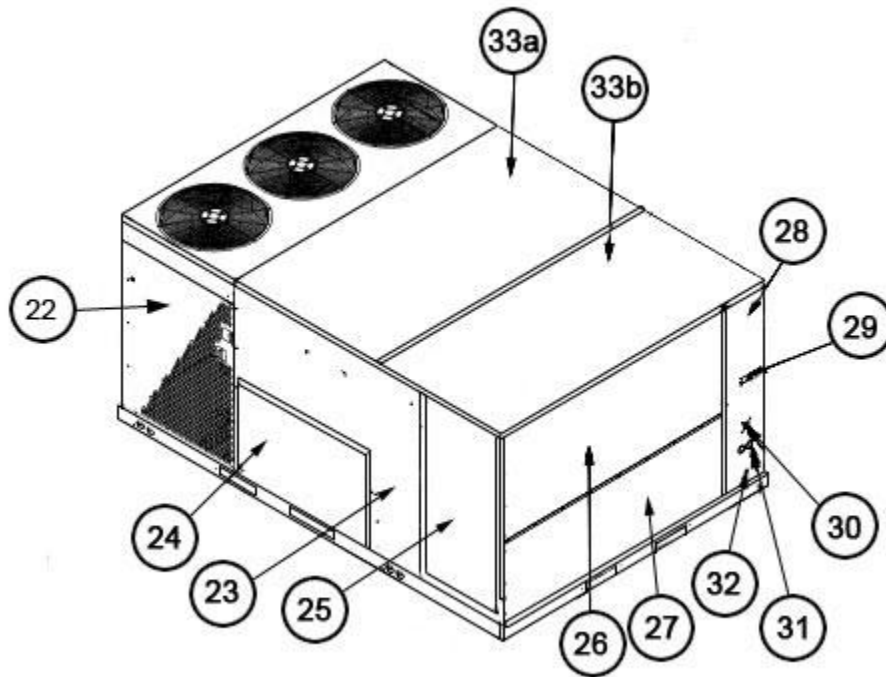

Exterior - Back 240

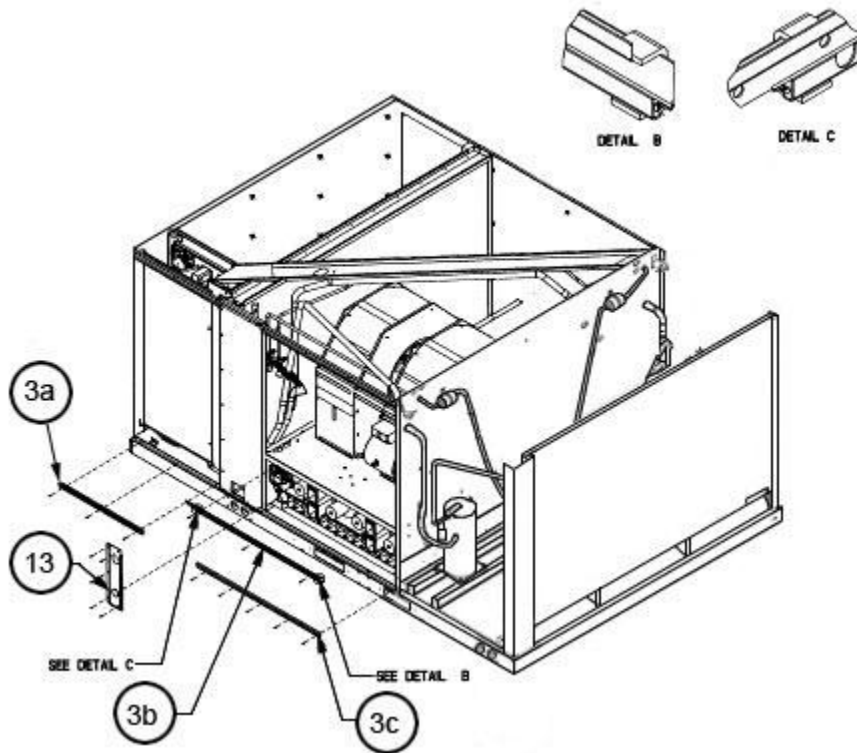

Front Panel Brackets 180

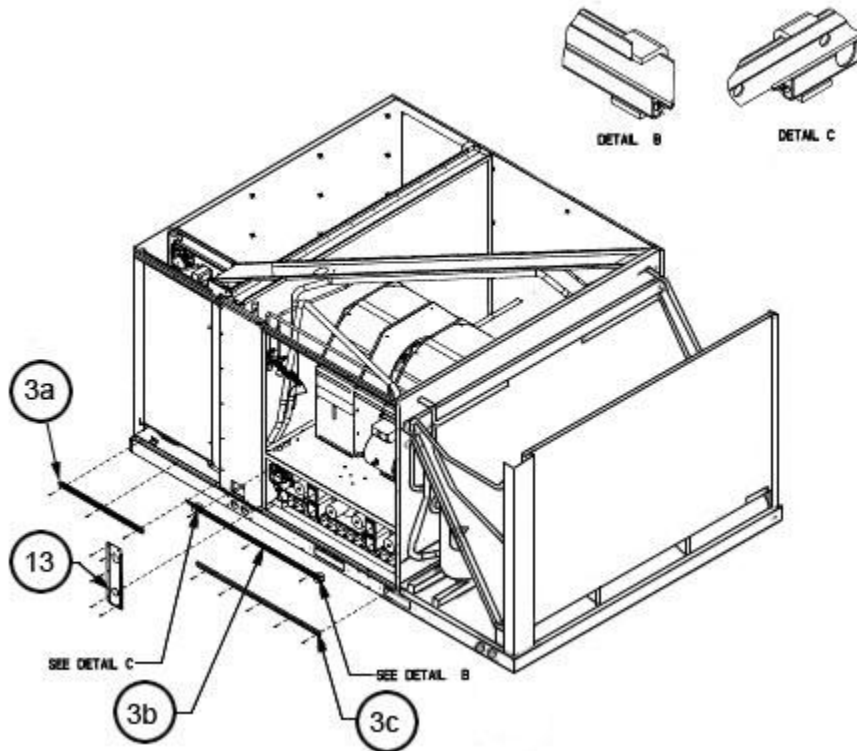

Front Panel Brackets 240

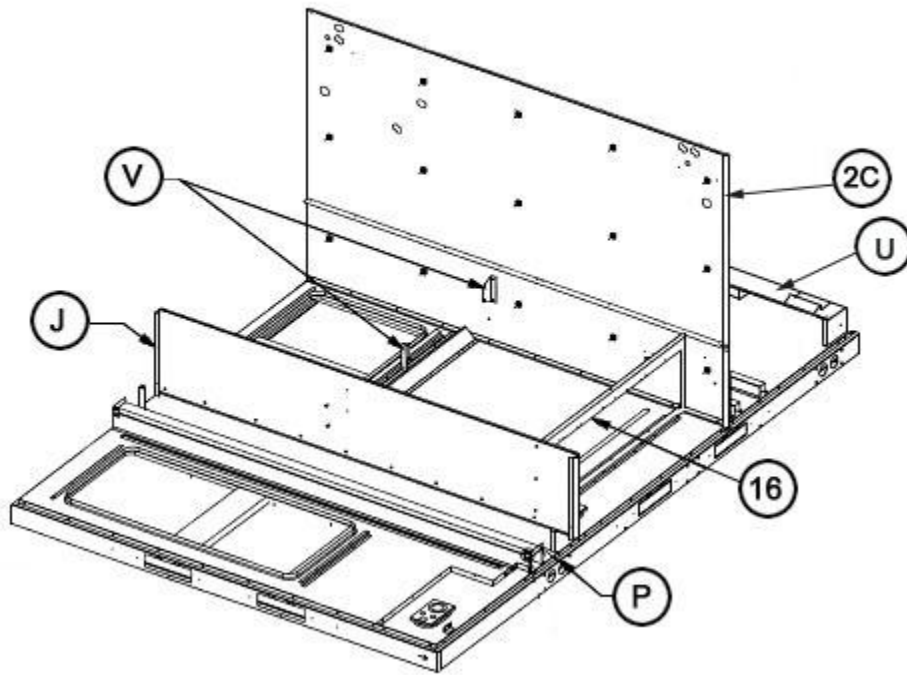

Heat Compartment 180-240

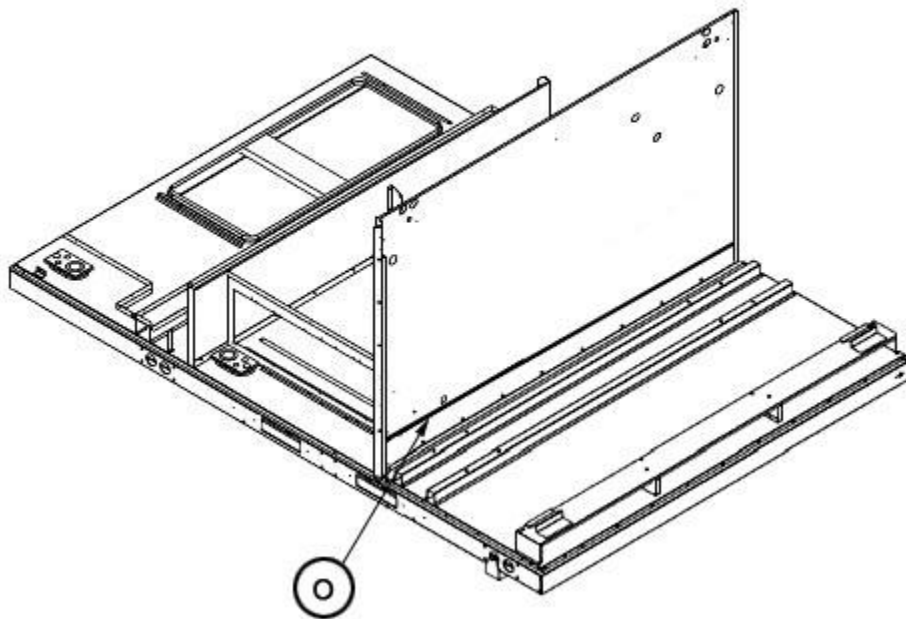

Condenser Bulkhead 180-240

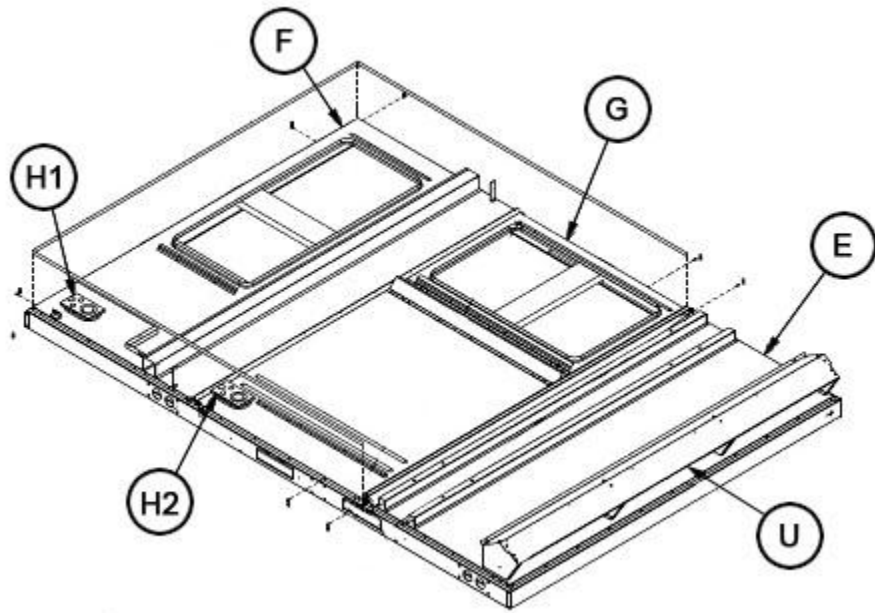

Base Pan Assembly 180-240

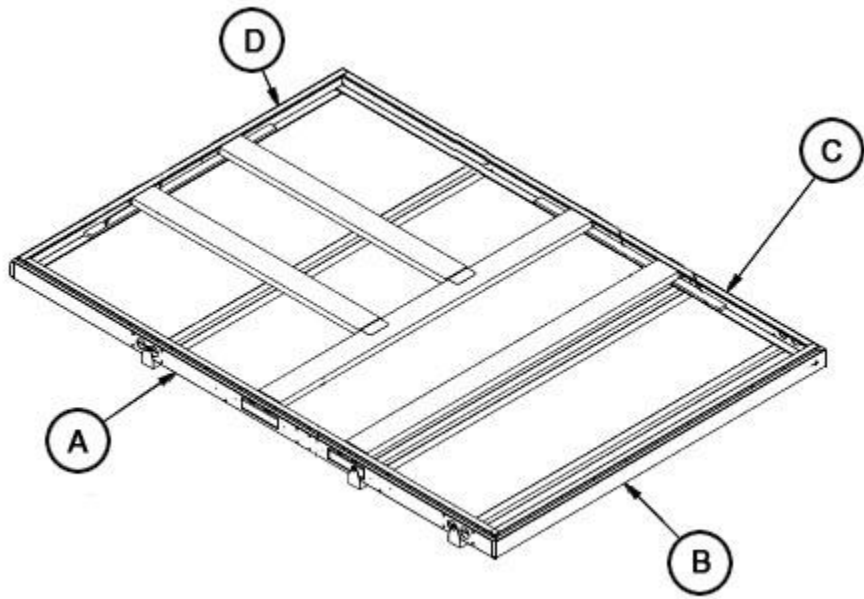

Base Rail Assembly 180-240

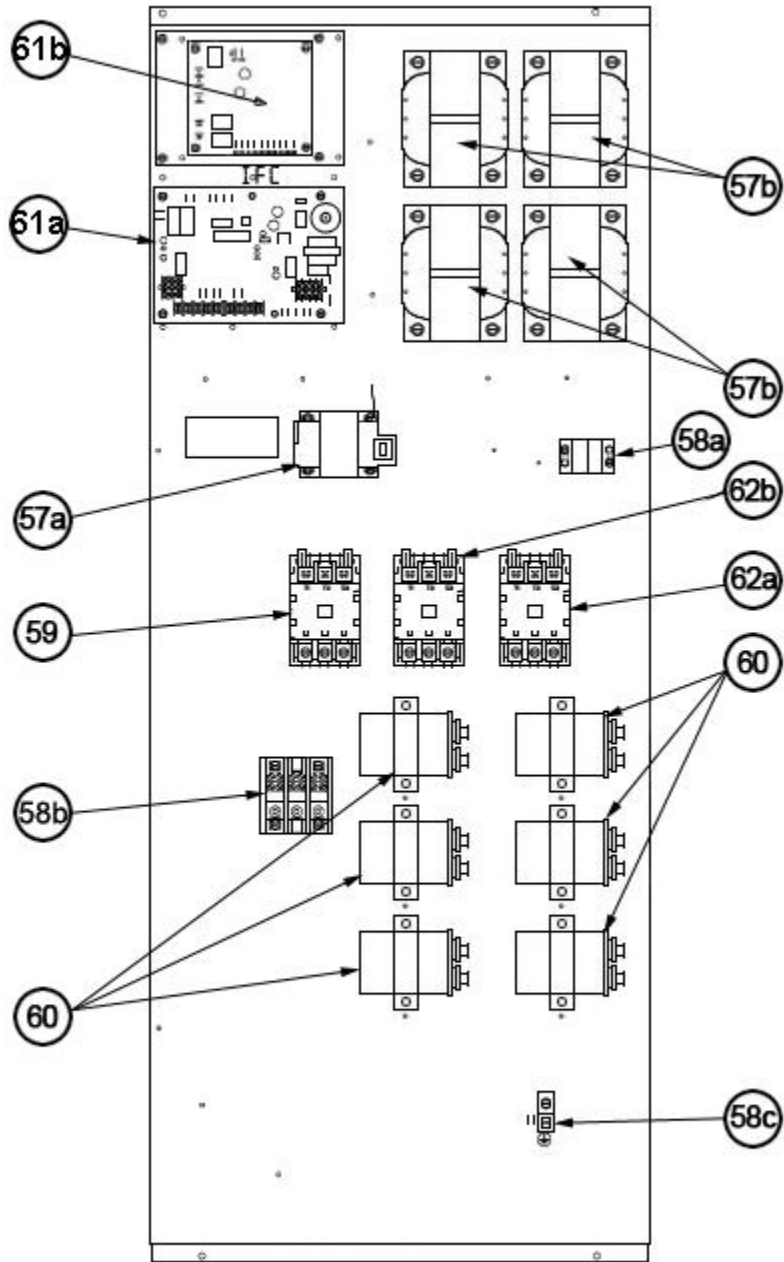

Control Box 180-240

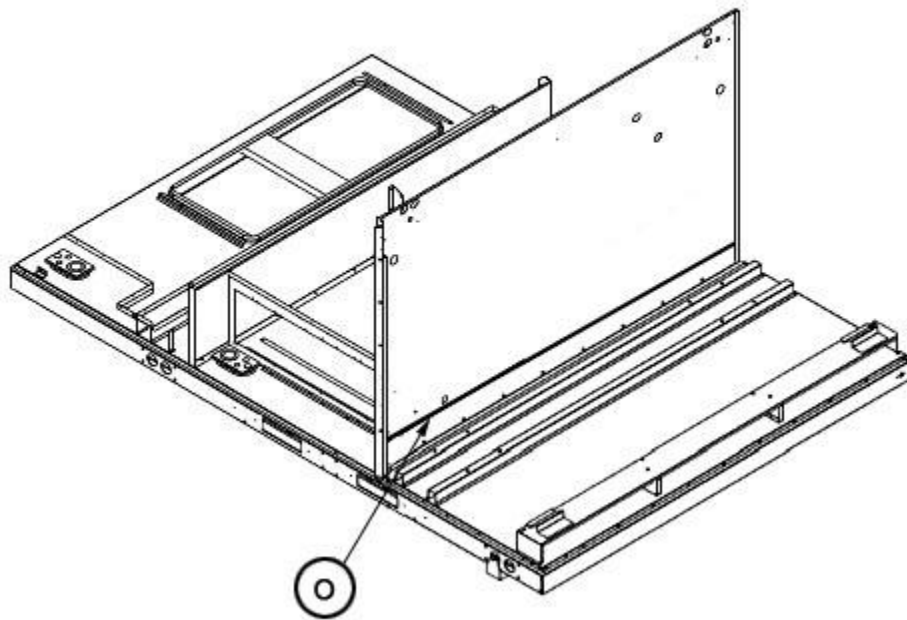

Condenser Bulkhead 180-240

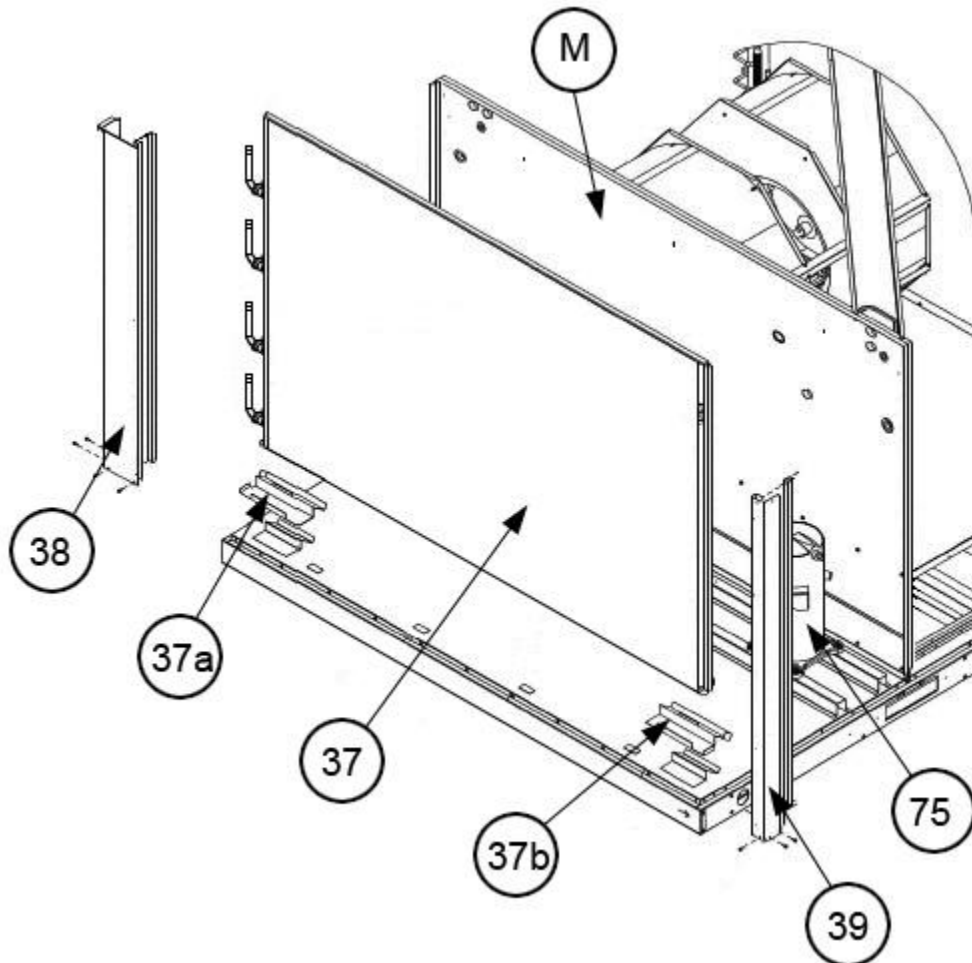

Condenser Coil 180

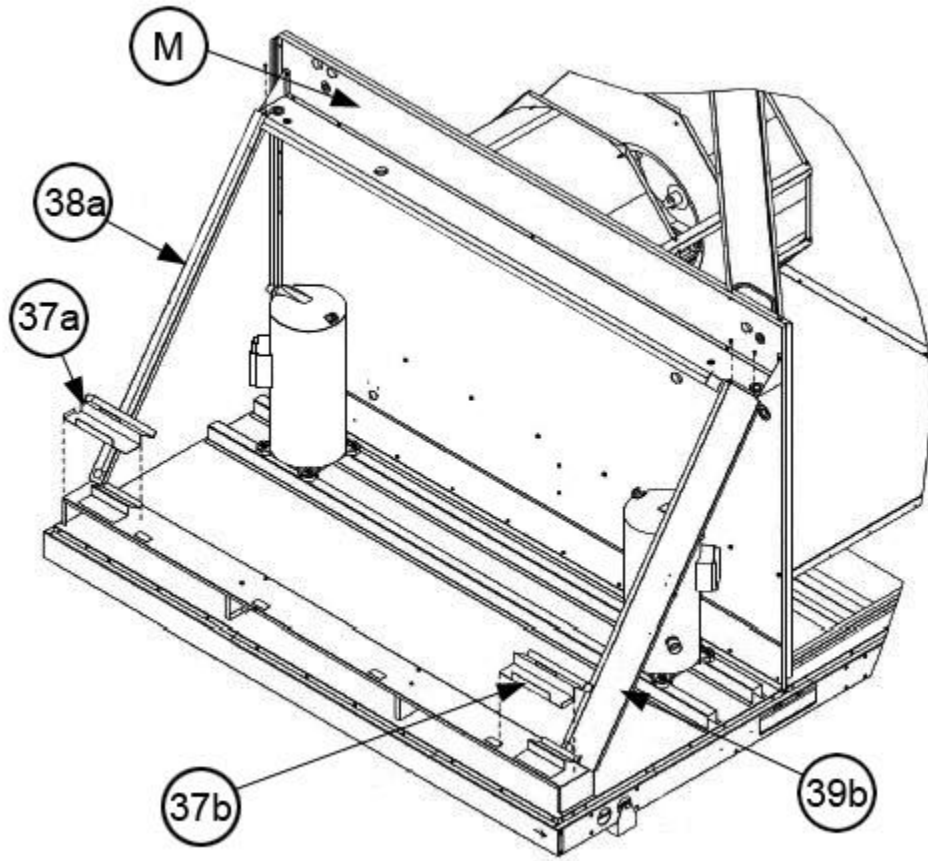

Condenser Coil Airstop - 240

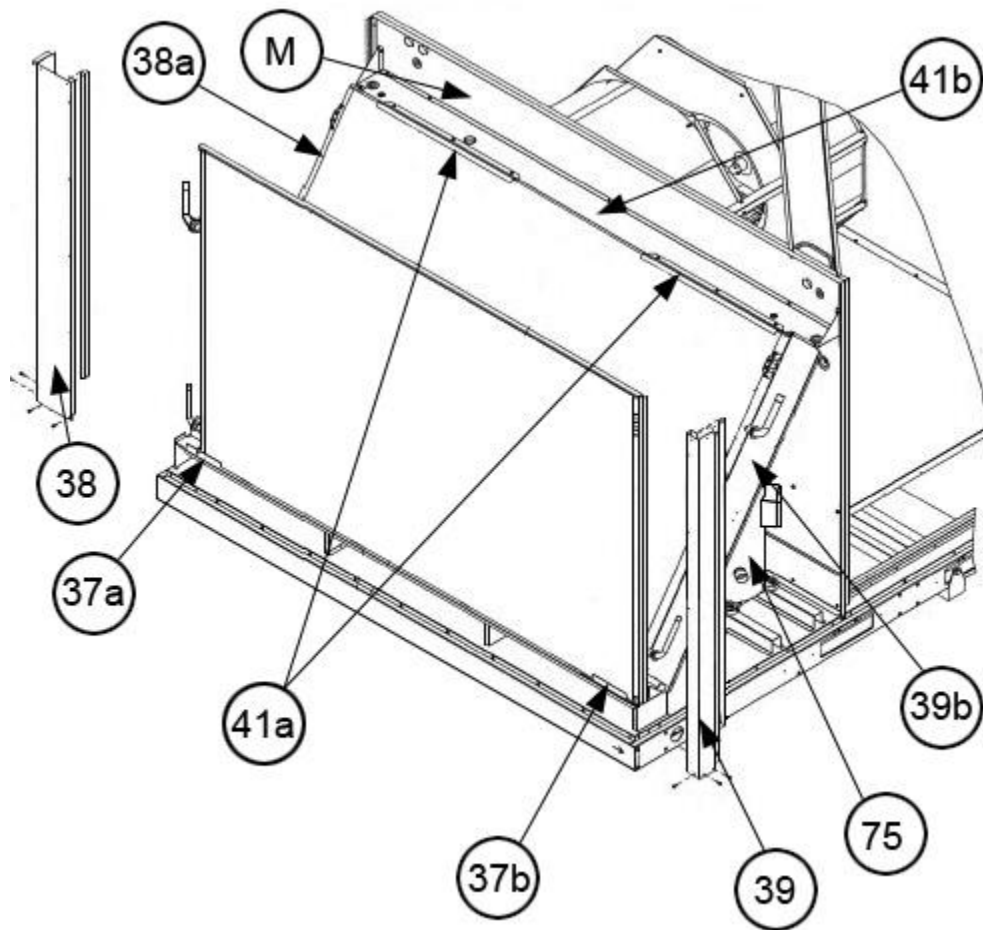

Condenser Coil - 240

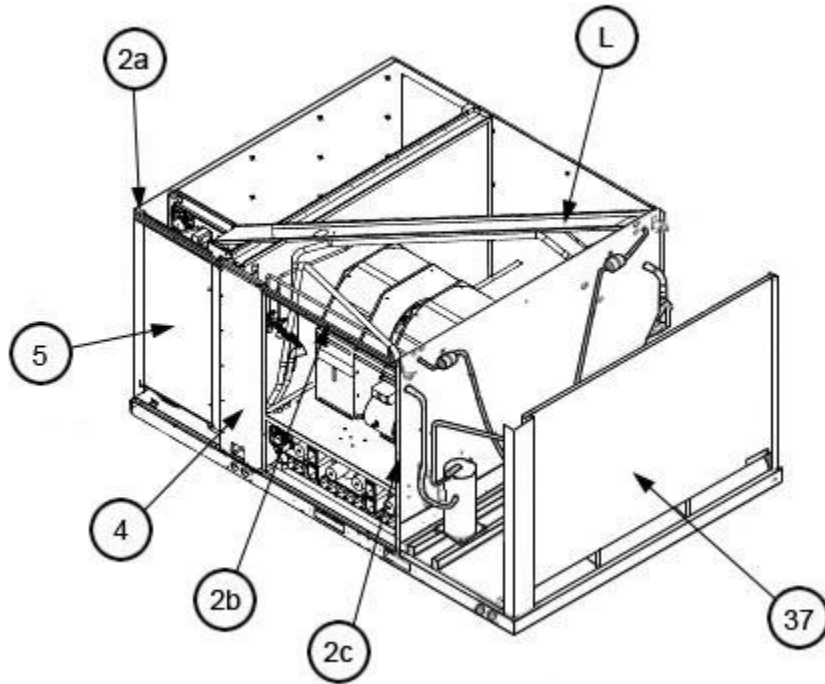

Interior - Front 180

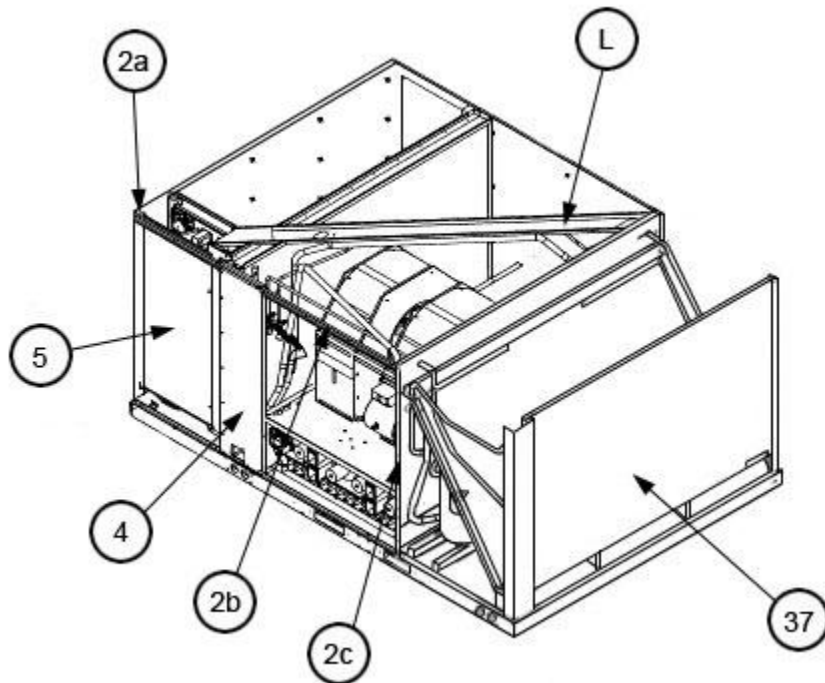

Interior - Front 240

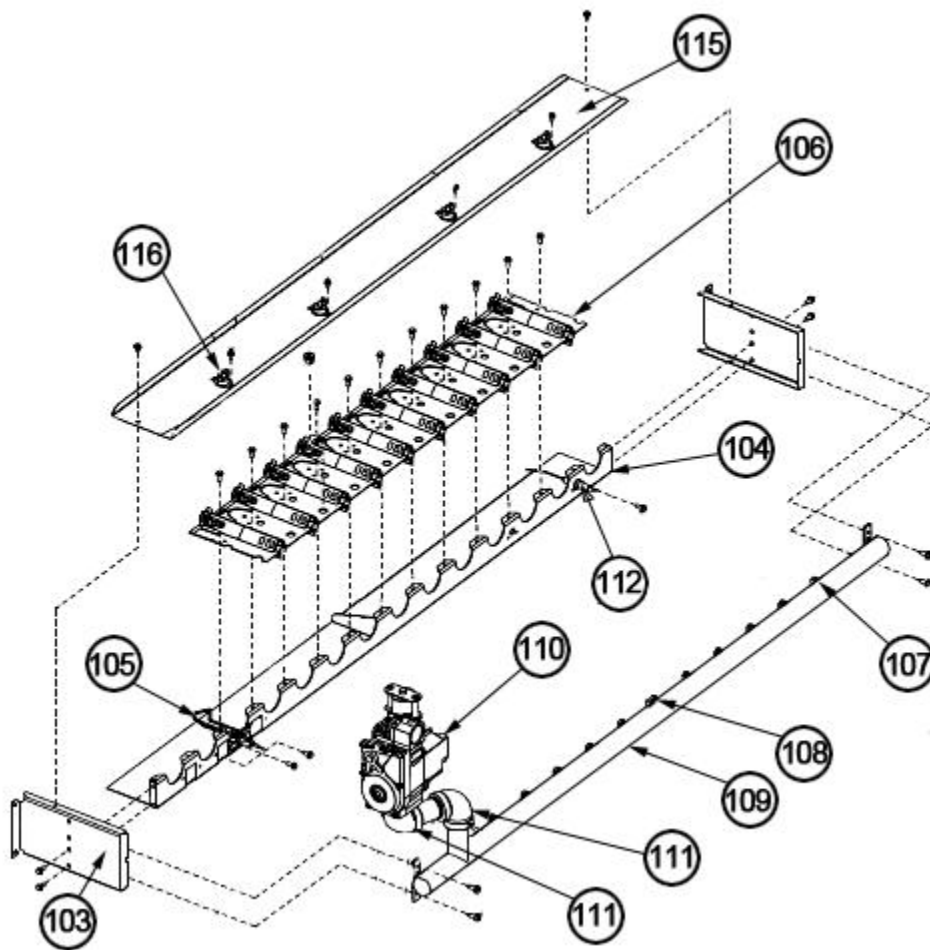

Burner Assembly 180-240

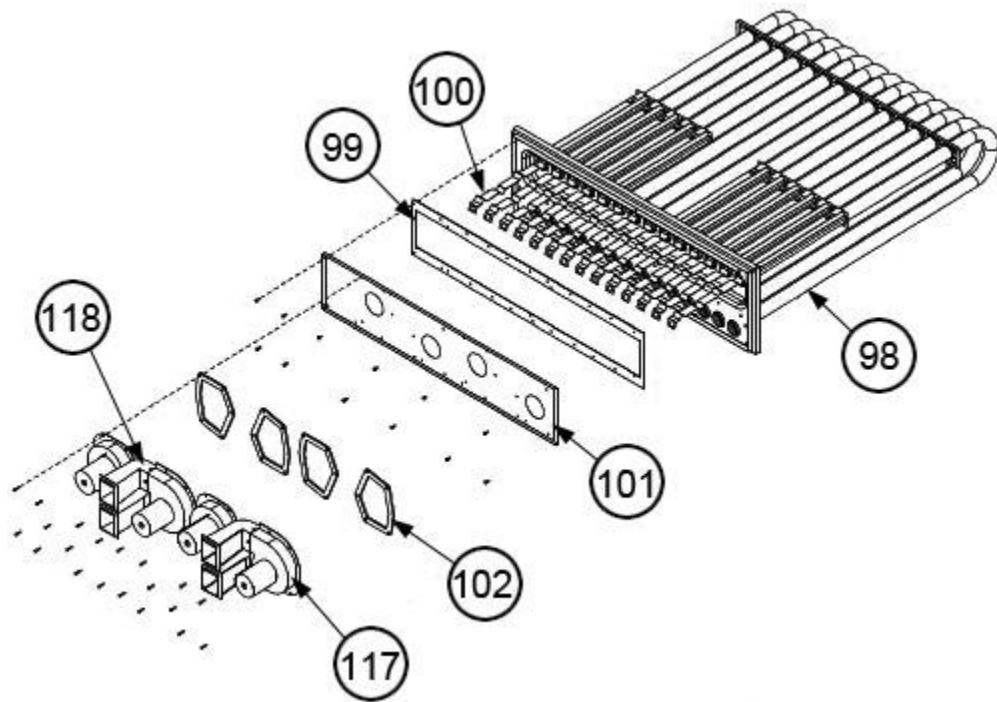

Heat Exchanger Assembly 180 - 240

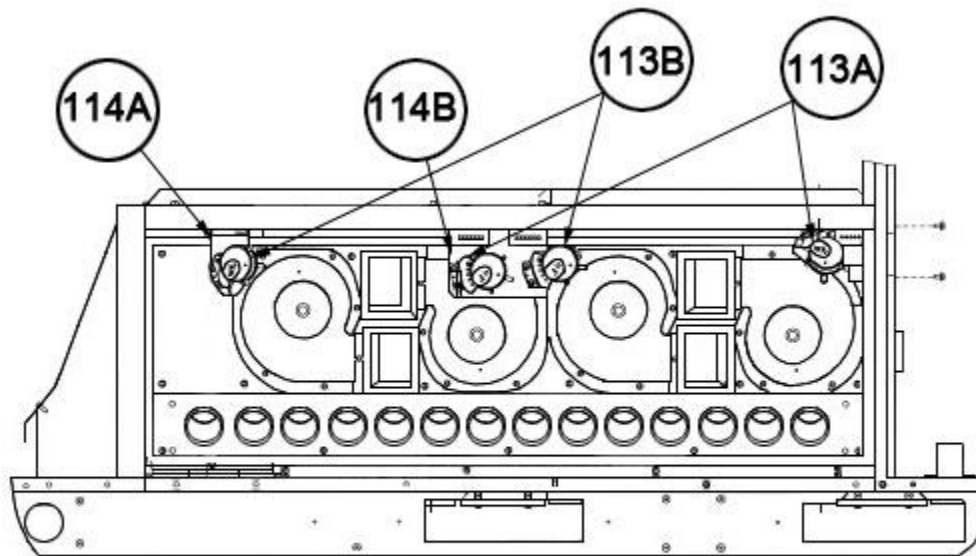

Pressure Switch - Mounting 180 - 240

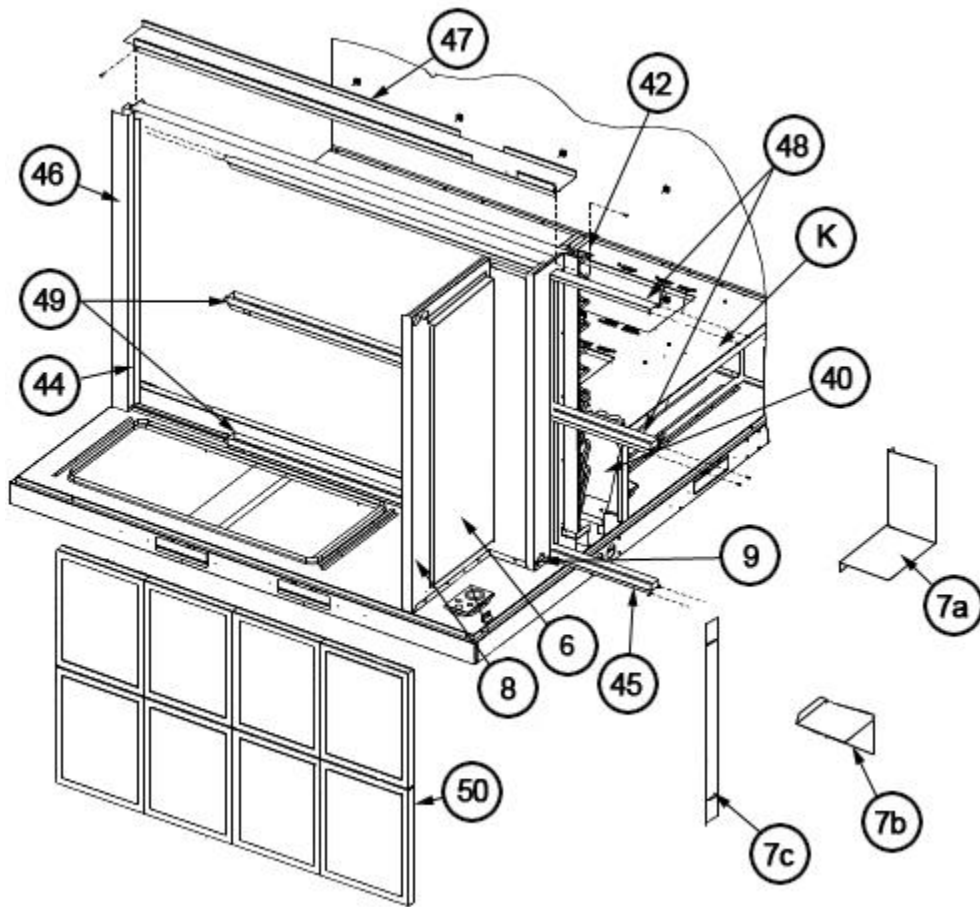

Filter Frame Assembly 180-240

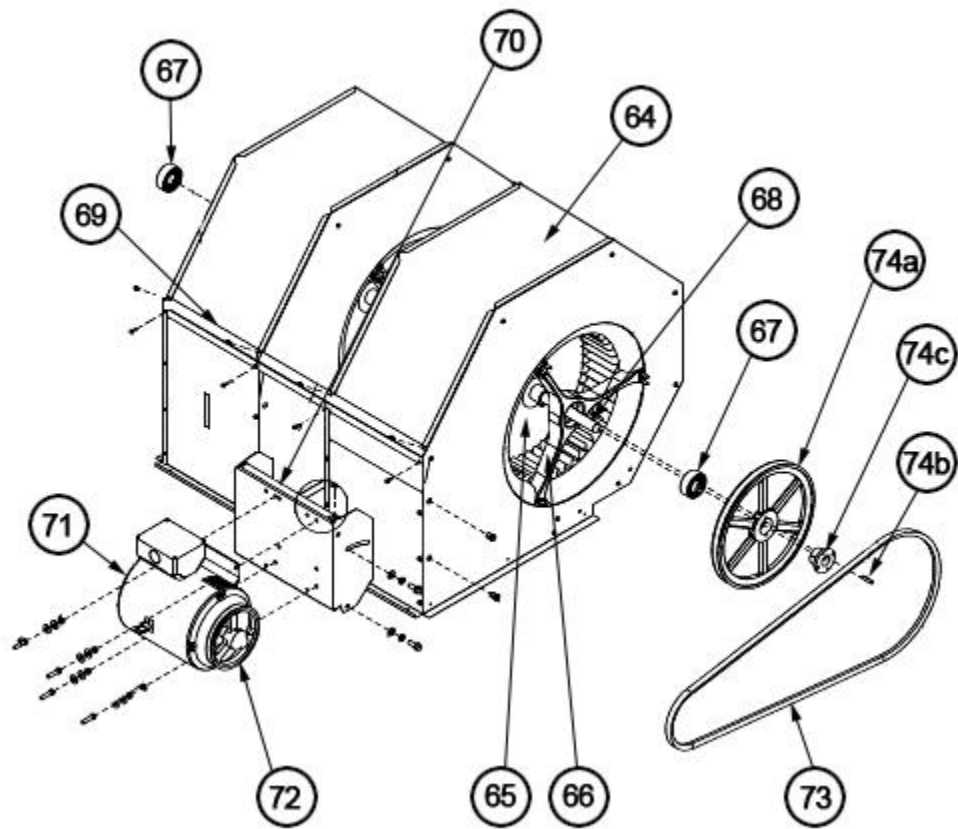

Blower Assembly 180-240

NOTES

Stk It is recommended that stock be maintained for this part.

N/A Not Applicable

- 1 Order the specified LP Conversion Kit.
- 2 Order Gas Valve for Natural Gas along with LP Conversion Kit.
- 3 The specified replacement pressure switch may have a different pressure setting than that originally supplied.
- 4 Older (Before F1811) filter frame components are not individually compatible with newer (After F1811) filter frame components. Depending upon availability of older (Before F1811) components, it may be necessary to replace entire filter frame assembly (Air Stops - Bottom and Side, Filter Channels and Filter Slides) with the newer style (After F1811) components.
- 5 On approximate Date Code 0213, the wire screens were removed from the Gas Heat Door inlet hood openings. If replacing the door on a unit manufactured after this date, new Inlet Flue Hoods (AE-90745-04) should be ordered. The new inlet hoods incorporate louvers to prevent entry of debris into the combustion chamber.

DISCLAIMER: This document is intended to provide general replacement parts information to aid qualified service personnel in the repair of these models. The complete Model and Serial Number of the unit under repair should be specified when selecting and ordering replacement parts. Specifications and illustrations are subject to change without notice. Document 92-42800-RKKL-B supersedes all previous parts lists for these models. See <http://www.rheempartslists.net/92-42800-RKKL-B> for the latest revision of this document. The manufacturer assumes no obligation for errors or omissions. Service personnel must verify the proper and safe operation of equipment after the replacement of any original components.