

# INSTALLATION INSTRUCTIONS

Package Gas Electric Featuring  
Industry Standard R-410A Refrigerant ~~R-410A~~  
RKKL (6 TON) SERIES

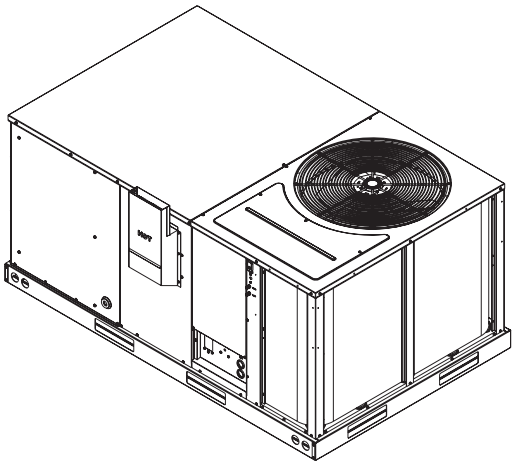

**AHRI** CERTIFIED™

**UL** US  
LISTED



**RECOGNIZE THIS SYMBOL AS AN INDICATION OF IMPORTANT SAFETY INFORMATION!**

## ▲ WARNING

IF THE INFORMATION IN THESE INSTRUCTIONS IS NOT FOLLOWED EXACTLY, A FIRE OR EXPLOSION MAY RESULT, CAUSING PROPERTY DAMAGE, PERSONAL INJURY OR DEATH.

## ▲ WARNING

THESE INSTRUCTIONS ARE INTENDED AS AN AID TO QUALIFIED SERVICE PERSONNEL FOR PROPER INSTALLATION, ADJUSTMENT AND OPERATION OF THIS UNIT. READ THESE INSTRUCTIONS THOROUGHLY BEFORE ATTEMPTING INSTALLATION OR OPERATION. FAILURE TO FOLLOW THESE INSTRUCTIONS MAY RESULT IN IMPROPER INSTALLATION, ADJUSTMENT, SERVICE OR MAINTENANCE, POSSIBLY RESULTING IN FIRE, ELECTRICAL SHOCK, CARBON MONOXIDE POISONING, EXPLOSION, PROPERTY DAMAGE, PERSONAL INJURY OR DEATH.

## ▲ WARNING

PROPOSITION 65 WARNING: THIS PRODUCT CONTAINS CHEMICALS KNOWN TO THE STATE OF CALIFORNIA TO CAUSE CANCER, BIRTH DEFECTS OR OTHER REPRODUCTIVE HARM.

## ▲ WARNING

- Do not store or use gasoline or other flammable vapors and liquids, or other combustible materials in the vicinity of this or any other appliance.
- WHAT TO DO IF YOU SMELL GAS
  - Do not try to light any appliance.
  - Do not touch any electrical switch; do not use any phone in your building.
  - Immediately call your gas supplier from a neighbor's phone. Follow the gas supplier's instructions.
  - If you cannot reach your gas supplier, call the fire department.
  - Do not return to your home until authorized by the gas supplier or fire department.
- DO NOT RELY ON SMELL ALONE TO DETECT LEAKS. DUE TO VARIOUS FACTORS, YOU MAY NOT BE ABLE TO SMELL FUEL GASES.
  - U.L. recognized fuel gas and CO detectors are recommended in all applications, and their installation should be in accordance with the manufacturer's recommendations and/or local laws, rules, regulations, or customs.
- Improper installation, adjustment, alteration, service or maintenance can cause injury, property damage or death. Refer to this manual. Installation and service must be performed by a qualified installer, service agency or the gas supplier. In the commonwealth of Massachusetts, installation must be performed by a licensed plumber or gas fitter for appropriate fuel.

**DO NOT DESTROY THIS MANUAL. PLEASE READ CAREFULLY AND KEEP IN A SAFE PLACE FOR FUTURE REFERENCE BY A SERVICEMAN.**



# I. TABLE OF CONTENTS

I. Table of Contents .....	2
II. Introduction .....	3
III. Checking Product Received .....	3
IV. Specifications.....	3
A. General .....	3
B. Major Components.....	3
C. R-410A Refrigerant .....	3
1. Specifications of R-410A.....	3
2. Quick Reference Guide for R-410A .....	4
3. Evaporator Coil/TXV .....	4
4. Tools Required for Installing and Servicing R-410A Models.....	4
V. Safety Information.....	4
VI. Unit Dimensions.....	5
VII. Installation.....	7
A. General .....	7
1. Pre-Installation Check .....	7
2. Location Considerations.....	7
B. Outside Installation.....	8
C. Attaching Exhaust and Combustion Air Inlet Hoods .....	9
D. Cover Panel Installation/Conversion Procedure .....	9
E. Clearances .....	9
F. Rooftop Installation .....	9
G. Ductwork .....	10
H. Return Air .....	11
VIII. Gas Supply, Condensate Drain and Piping .....	13
A. Gas Connection .....	13
B. LP Conversion.....	14
C. NOx Models .....	14
D. Adjusting or Checking Furnace Input.....	15
E. Condensate Drain .....	17
IX. Wiring.....	17
A. Power Supply .....	17
B. Hook Up .....	19
C. Internal Wiring .....	19
D. Thermostat .....	19
X. Furnace Section Controls and Ignition System.....	20
Normal Furnace Operating Sequence.....	20
Operating Instructions .....	20
Burners .....	21
Manual Reset Overtemperature Control.....	21
Pressure Switch.....	21
Limit Control .....	22
XI. System Operating Information .....	22
Advise the Customer .....	22
Furnace Section Maintenance.....	22
Lubrication .....	23
Cooling Section Maintenance.....	23
Replacement Parts .....	24
Troubleshooting.....	24
Wiring Diagrams .....	24
Charging.....	24
XII. General Data .....	25-27
XIII. Miscellaneous .....	28
Electrical Data .....	28
Airflow Performance .....	29
Wiring Diagrams.....	30-32
Charge Charts .....	33
Troubleshooting.....	34-38

 Recognize this symbol as an indication of Important Safety Information!

## WARNING

THE MANUFACTURER'S WARRANTY DOES NOT COVER ANY DAMAGE OR DEFECT TO THE AIR CONDITIONER CAUSED BY THE ATTACHMENT OR USE OF ANY COMPONENTS, ACCESSORIES OR DEVICES (OTHER THAN THOSE AUTHORIZED BY THE MANUFACTURER) INTO, ONTO OR IN CONJUNCTION WITH THE AIR CONDITIONER. YOU SHOULD BE AWARE THAT THE USE OF UNAUTHORIZED COMPONENTS, ACCESSORIES OR DEVICES MAY ADVERSELY AFFECT THE OPERATION OF THE AIR CONDITIONER AND MAY ALSO ENDANGER LIFE AND PROPERTY. THE MANUFACTURER DISCLAIMS ANY RESPONSIBILITY FOR SUCH LOSS OR INJURY RESULTING FROM THE USE OF SUCH UNAUTHORIZED COMPONENTS, ACCESSORIES OR DEVICES.

## WARNING

INSTALL THIS UNIT ONLY IN A LOCATION AND POSITION AS SPECIFIED IN THE LOCATION REQUIREMENTS AND CONSIDERATIONS SECTION OF THESE INSTRUCTIONS. PROVIDE ADEQUATE COMBUSTION AND VENTILATION AIR TO THE UNIT SPACE AS SPECIFIED IN THE VENTING SECTION OF THESE INSTRUCTIONS.

## WARNING

PROVIDE ADEQUATE COMBUSTION AND VENTILATION AIR TO THE UNIT SPACE AS SPECIFIED IN THE COMBUSTION AND VENTILATION AIR SECTION OF THESE INSTRUCTIONS.

## II. INTRODUCTION

This booklet contains the installation and operating instructions for your combination gas heating/electric cooling unit. There are some precautions that should be taken to derive maximum satisfaction from it. Improper installation can result in unsatisfactory operation or dangerous conditions.

Read this booklet and any instructions packaged with separate equipment required to make up the system prior to installation. Give this booklet to the owner and explain its provisions. The owner should retain this booklet for future reference.

## III. CHECKING PRODUCT RECEIVED

Upon receiving the unit, inspect it for any damage from shipment. Claims for damage, either shipping or concealed, should be filed immediately with the shipping company.

**IMPORTANT:** Check the unit model number, heating size, electrical characteristics, and accessories to determine if they are correct.

## V. SPECIFICATIONS

### A. GENERAL

The Combination Gas Heating/Electric Cooling Rooftop is available in 100,000 and 135,000 BTU/Hr. heating inputs and cooling capacity of 6 nominal tons of cooling. Units are convertible from bottom supply and return to side supply and return by relocation of supply and return air access panels. See cover installation detail.

The units are weatherized for mounting outside of the building.

## WARNING

UNITS ARE NOT DESIGN CERTIFIED TO BE INSTALLED INSIDE THE STRUCTURE. DOING SO CAN CAUSE INADEQUATE UNIT PERFORMANCE AS WELL AS PROPERTY DAMAGE AND CARBON MONOXIDE POISONING RESULTING IN PERSONAL INJURY OR DEATH.

The information on the rating plate is in compliance with the FTC and DOE rating for single phase units. The following information is for three phase units which **are not** covered under the DOE certification program.

1. The energy consumption of the ignition system used with this unit is 9 watts.
2. The efficiency rating of this unit is a product thermal efficiency rating determined under continuous operating conditions independent of any installed system.

### B. MAJOR COMPONENTS

The unit includes a hermetically-sealed refrigerating system (consisting of a scroll compressor, condenser coil, evaporator coil with thermostatic expansion valve), a circulation air blower, a condenser fan, a heat exchanger assembly, gas burner and control assembly, combustion air motor and fan, and all necessary internal electrical wiring. The cooling system of these units is factory-evacuated, charged with R-410A refrigerant and performance tested. Refrigerant amount and type are indicated on rating plate.

### C. R410A REFRIGERANT

All units are factory charged with R-410A refrigerant.

#### 1. Specification of R-410A:

**Application:** R-410A is not a drop-in replacement for R-22; equipment designs must accommodate its higher pressures. It cannot be retrofitted into R-22 units.

**Pressure:** The pressure of R-410A is approximately 60% (1.6 times) greater than R-22. Recovery and recycle equipment, pumps, hoses and the like need to have design pressure ratings appropriate for R-410A. *Manifold sets need to range up to 800 psig high-side and 250 psig low-side with a 550 psig low-side retard. Hoses need to have a service pressure rating of 800 psig. Recovery cylinders need to have a 400 psig service pressure rating. DOT 4BA400 or DOT BW400.*

**Combustibility:** At pressures above 1 atmosphere, mixture of R-410A and air can become combustible. R-410A and air should never be mixed in tanks or supply

**lines, or be allowed to accumulate in storage tanks. Leak checking should never be done with a mixture of R-410A and air.** Leak checking can be performed safely with nitrogen or a mixture of R-410A and nitrogen.

## 2. Quick Reference Guide For R-410A

- R-410A refrigerant operates at approximately 60% higher pressure (1.6 times) than R-22. Ensure that servicing equipment is designed to operate with R-410A.
- R-410A refrigerant cylinders are pink.
- R-410A, as with other HFC's is only compatible with POE oils.
- Vacuum pumps will not remove moisture from POE oil.
- R-410A systems are to be charged with liquid refrigerants. Prior to March 1999, R-410A refrigerant cylinders had a dip tube. These cylinders should be kept upright for equipment charging. Post March 1999 cylinders do not have a dip tube and should be inverted to ensure liquid charging of the equipment.
- Do not install a suction line filter drier in the liquid line.
- A liquid line filter drier is standard on every unit.
- Desiccant (drying agent) must be compatible for POE oils and R-410A

## 3. Evaporator Coil / TXV

The thermostatic expansion valve is specifically designed to operate with R-410A. **DO NOT use an R-22 TXV. The existing evaporator must be replaced with the factory specified TXV evaporator specifically designed for R-410A.**

## 4. Tools Required For Installing & Servicing R-410A Models

Manifold Sets:

- Up to 800 PSIG High side
- Up to 250 PSIG Low Side
- 550 PSIG Low Side Retard

Manifold Hoses:

- Service Pressure Rating of 800 PSIG

Recovery Cylinders:

- 400 PSIG Pressure Rating
- Dept. of Transportation 4BA400 or BW400

### CAUTION

R-410A systems operate at higher pressures than R-22 systems. Do not use R-22 service equipment or components on R-410A equipment.

## V. SAFETY INFORMATION

### WARNING

**USE ONLY WITH TYPE OF GAS APPROVED FOR THIS UNIT. REFER TO THE UNIT RATING PLATE.**

# VI. UNIT DIMENSIONS

## RKKL 6 TON [21.1 kW] MODELS

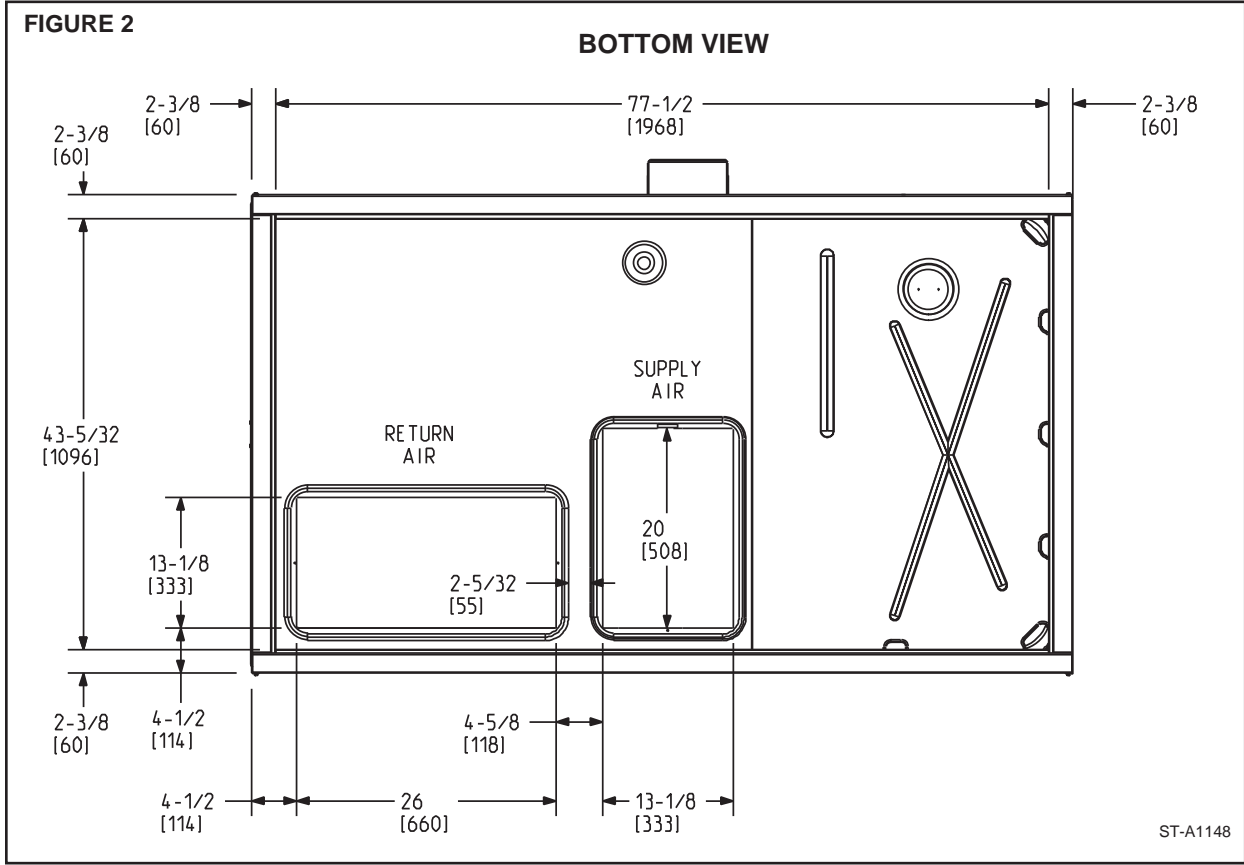
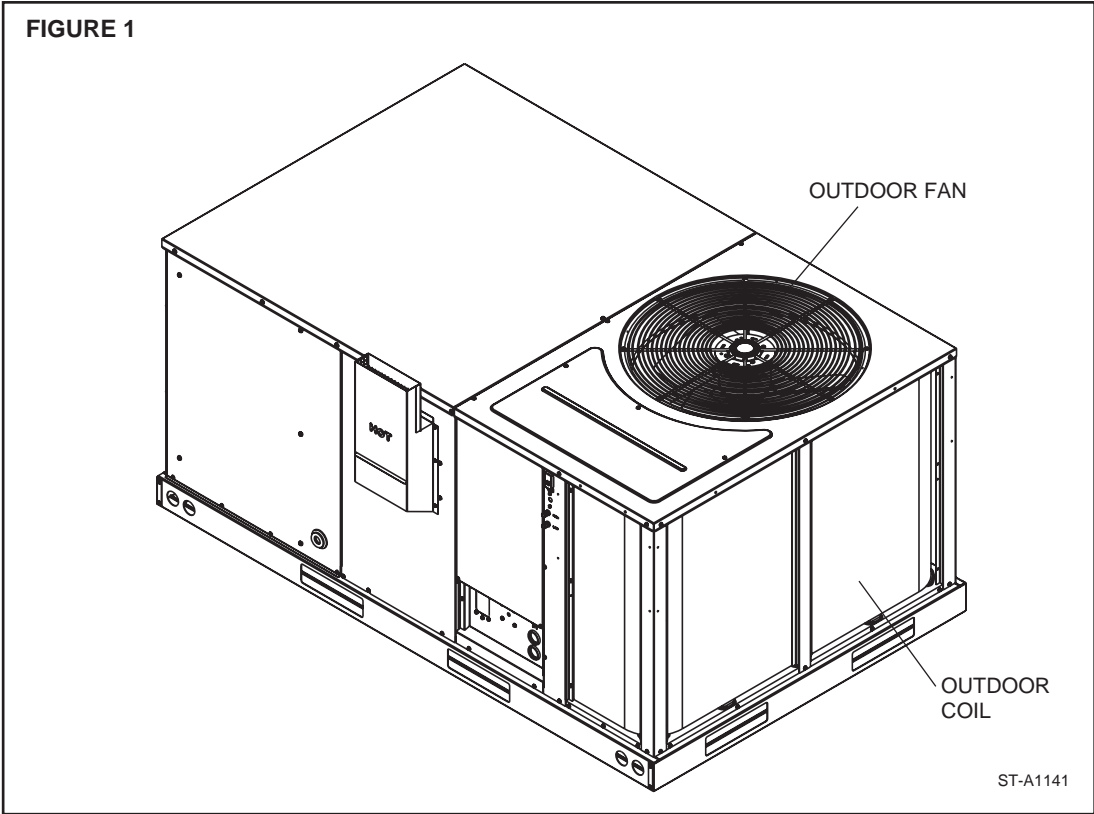

FIGURE 3

BACK VIEW

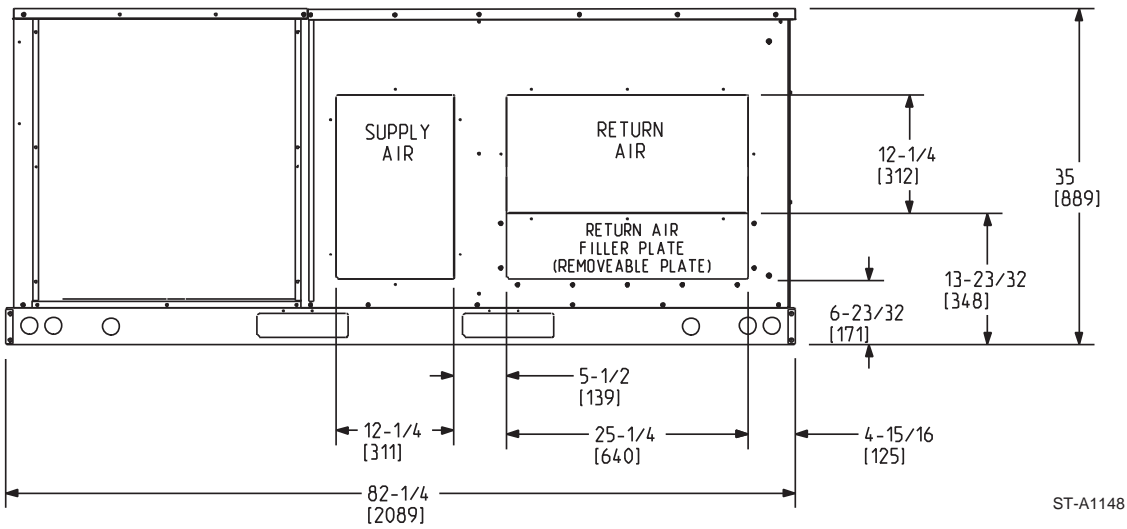

FIGURE 4

SIDE VIEW

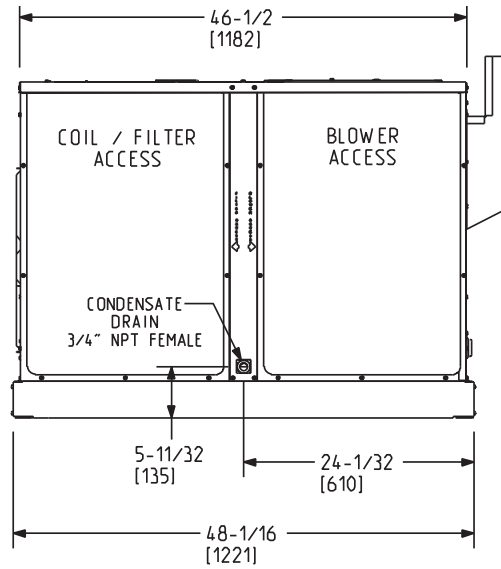
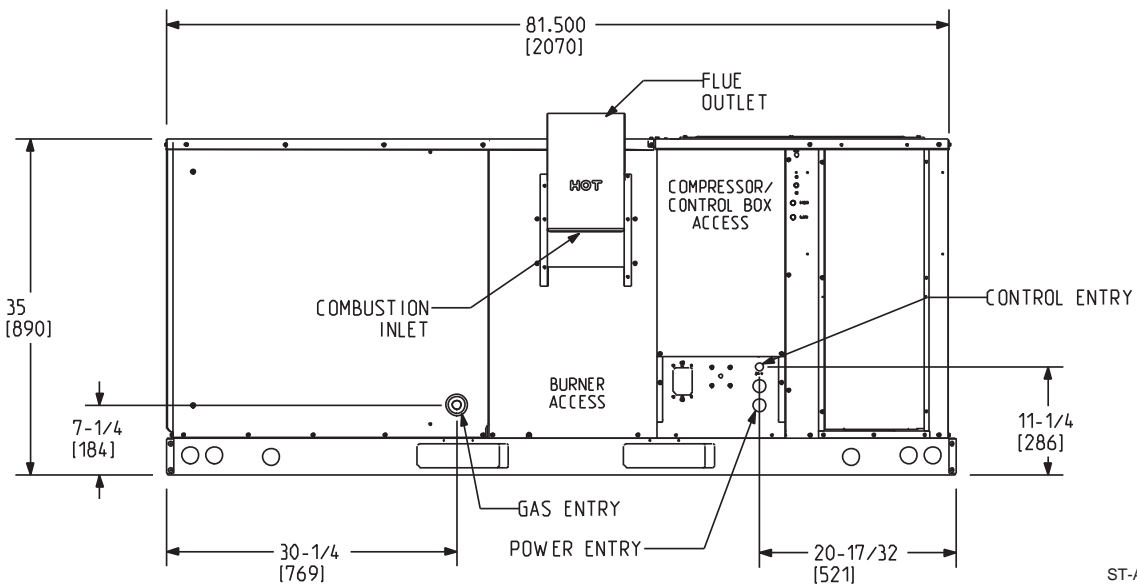

FIGURE 5

FRONT VIEW



## WARNING

NEVER TEST FOR GAS LEAKS WITH AN OPEN FLAME. USE A COMMERCIALY AVAILABLE SOAP SOLUTION MADE SPECIFICALLY FOR THE DETECTION OF LEAKS TO CHECK ALL CONNECTIONS, AS SPECIFIED IN GAS SUPPLY AND PIPING SECTION OF THESE INSTRUCTIONS.

## WARNING

ALWAYS INSTALL UNIT TO OPERATE WITHIN THE UNIT'S INTENDED TEMPERATURE-RISE RANGE WITH A DUCT SYSTEM WHICH HAS AN EXTERNAL STATIC PRESSURE WITHIN THE ALLOWABLE RANGE, AS SPECIFIED IN DUCTING SECTION OF THESE INSTRUCTIONS. SEE ALSO UNIT RATING PLATE.

## WARNING

WHEN A UNIT IS INSTALLED SO THAT SUPPLY DUCTS CARRY AIR CIRCULATED BY THE UNIT TO AREAS OUTSIDE THE SPACE CONTAINING THE UNIT, THE RETURN AIR SHALL ALSO BE HANDLED BY DUCT(S) SEALED TO THE UNIT CASING AND TERMINATING OUTSIDE THE SPACE CONTAINING THE UNIT.

# VII. INSTALLATION

## A. GENERAL

Install this unit in accordance with The American National Standard Z223.1-latest edition booklet entitled "National Fuel Gas Code," and the requirements or codes of the local utility or other authority having jurisdiction.

Additional helpful publications available from the "National Fire Protection Association" are: NFPA-90A - Installation of Air Conditioning and Ventilating Systems 1985 or latest edition. NFPA-90B - Warm Air Heating and Air Conditioning Systems 1984.

These publications are available from:

National Fire Protection Association, Inc.  
1 Batterymarch Park  
Quincy, MA 02169-7471  
[www.nfpa.org](http://www.nfpa.org)

1. PRE-INSTALLATION CHECK-POINTS — Before attempting any installation, carefully consider the following points:

Structural strength of supporting members  
(Rooftop Installation)  
Clearances and provision for servicing  
Power supply and wiring  
Gas supply and piping  
Air duct connections and sizing  
Drain facilities and connections  
Location for minimum noise and vibration - away from bedroom windows

2. LOCATION CONSIDERATIONS

The metal parts of this unit may be subject to rust or deterioration in adverse environmental conditions. This oxidation could shorten the equipment's useful life. Salt spray, fog or mist in seacoast areas, sulphur or chlorine from lawn watering systems, and various chemical contaminants from industries such as paper mills and petroleum refineries are especially corrosive.

**If the unit is to be installed in an area where contaminants are likely to be a problem, give special attention to the equipment location and exposure.**

1. Avoid having lawn sprinkler heads spray directly on the unit cabinet.
2. In coastal areas locate the unit on the side of the building away from the waterfront.
3. Shielding by a fence or shrubs may give some protection.

## WARNING

**DISCONNECT ALL POWER TO UNIT BEFORE STARTING MAINTENANCE. FAILURE TO DO SO CAN CAUSE ELECTRICAL SHOCK RESULTING IN PERSONAL INJURY OR DEATH. REGULAR MAINTENANCE WILL REDUCE THE BUILDUP OF CONTAMINANTS AND HELP TO PROTECT THE UNIT'S FINISH.**

1. Frequent washing of the cabinet, fan blade and coil with fresh water will remove most of the salt or other contaminants that build up on the unit.
2. Regular cleaning and waxing of the cabinet with a good automobile polish will provide some protection.
3. A good liquid cleaner may be used several times a year to remove matter that will not wash off with water.

Several different types of protective coatings are offered in some areas. These coatings may provide some benefit, but the effectiveness of such coating materials cannot be verified by the equipment manufacturer.

**The best protection is frequent cleaning, maintenance and minimal exposure to contaminants.**

## **⚠ WARNING**

THIS UNIT MAY BE USED TO HEAT THE BUILDING OR STRUCTURE DURING CONSTRUCTION IF THE FOLLOWING INSTALLATION REQUIREMENTS ARE MET. INSTALLATION MUST COMPLY WITH ALL INSTALLATION INSTRUCTIONS INCLUDING:

- PROPER VENT INSTALLATION;
- FURNACE OPERATING UNDER THERMOSTATIC CONTROL;
- RETURN AIR DUCT SEALED TO THE FURNACE;
- AIR FILTERS IN PLACE;
- SET FURNACE INPUT RATE AND TEMPERATURE RISE PER RATING PLATE MARKING;
- MEANS OF PROVIDING OUTDOOR AIR REQUIRED FOR COMBUSTION;
- RETURN AIR TEMPERATURE MAINTAINED BETWEEN 55°F (13°C) AND 80°F (27°C); AND
- INSTALLATION OF EXHAUST AND COMBUSTION AIR INLET HOODS COMPLETED;
- CLEAN FURNACE, DUCT WORK AND COMPONENTS UPON SUBSTANTIAL COMPLETION OF THE CONSTRUCTION PROCESS, AND VERIFY FURNACE OPERATING CONDITIONS INCLUDING IGNITION, INPUT RATE, TEMPERATURE RISE AND VENTING, ACCORDING TO THE INSTRUCTIONS.

**FIGURE 6**

**OUTSIDE SLAB INSTALLATION. CLOSET DISTRIBUTION SYSTEM. SLAB FLOOR CONSTRUCTION.**

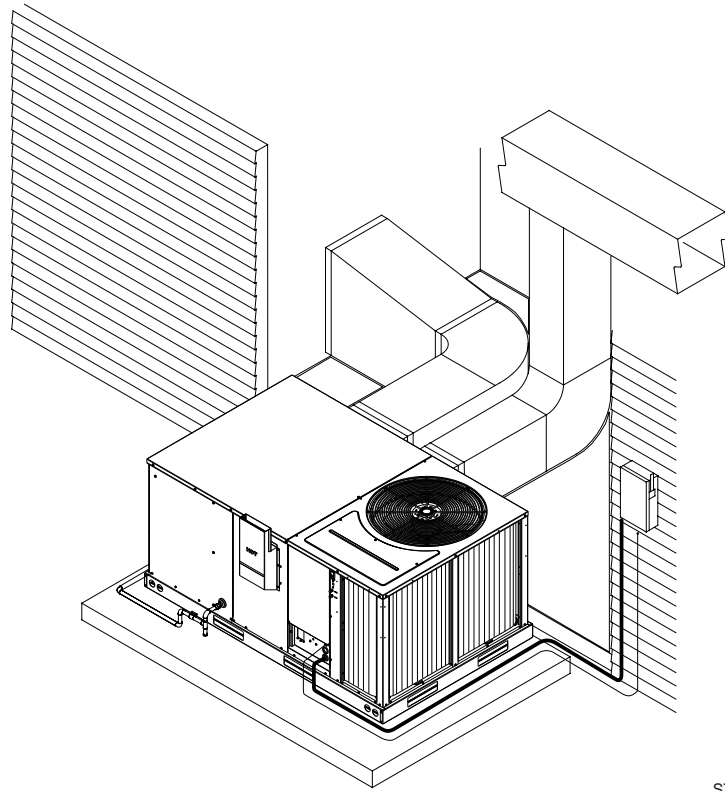

ST-A1141-12

## **B. OUTSIDE SLAB INSTALLATION**

### **⚠ WARNING**

THESE UNITS ARE DESIGNED CERTIFIED FOR OUTDOOR INSTALLATION ONLY. INSTALLATION INSIDE ANY PART OF A STRUCTURE CAN RESULT IN INADEQUATE UNIT PERFORMANCE AS WELL AS PROPERTY DAMAGE. INSTALLATION INSIDE CAN ALSO CAUSE RECIRCULATION OF FLUE PRODUCTS INTO THE CONDITIONED SPACE RESULTING IN PERSONAL INJURY OR DEATH.

(Typical outdoor slab installation is shown in Figure 6.)

1. Select a location where external water drainage cannot collect around unit.
2. Provide a level slab sufficiently high enough above grade to prevent surface water from entering the unit
3. The location of the unit should be such as to provide proper access for inspection and servicing as shown in Figure 8.
4. Locate unit where operating sounds will not disturb owner or neighbors.
5. Locate unit so roof runoff water does not pour directly on the unit. Provide gutter or other shielding at roof level. Do not locate unit in an area where excessive snow drifting may occur or accumulate.
6. Where snowfall is anticipated, the height of the unit above the ground level must be considered. Mount unit high enough to be above anticipated maximum area snowfall and to allow combustion air to enter the combustion air inlet.
7. Select an area which will keep the areas of the vent, air intake, and A/C condenser fins free and clear of obstructions such as weeds, shrubs, vines, snow, etc. Inform the user accordingly.
8. Remove compressor shipping supports (if so equipped) after installation.



## C. ATTACHING EXHAUST AND COMBUSTION AIR INLET HOODS

**IMPORTANT:** Do not operate this unit without the exhaust/combustion air inlet hood properly installed. This hood is shipped in a carton in the blower compartment inside the unit and must be attached when the unit is installed. See Figure 3.

To attach exhaust/combustion air inlet hood:

1. Remove screws securing blower access panel and remove access panel. For location of blower access panel, see Figure 2.
2. Remove exhaust/combustion air inlet hood from the carton, located inside the blower compartment.
3. Attach blower access panel.
4. Attach the combustion air inlet/exhaust hood with screws. Reference Figure 3 for proper location. Screws are in carton with the hood.
5. Vent the unit using the flue exhaust hood, as supplied from the factory, without alteration or addition.

## D. COVER PANEL INSTALLATION/CONVERSION PROCEDURE

### DOWNFLOW TO HORIZONTAL

1. Remove the screws and covers from the outside of the supply and return sections.
2. Install the covers in the bottom supply and return openings with the painted side up. See Figure 7. Use the existing gasket to seal the covers.
3. Secure the supply cover to the base of the unit with 1 screw, engaging prepunched tab in unit base.
4. Secure the return cover to the base of the unit with screws engaging prepunched holes in the unit base.

## E. CLEARANCES

The following minimum clearances must be observed for proper unit performance and serviceability. Reference Figure 8.

**NOTE:** Supply duct may be installed with "0" inch clearance to combustible materials, provided 1" minimum Fiberglass insulation is applied either inside or on the outside of the duct.

## F. ROOFTOP INSTALLATION

1. Before locating the unit on the roof, make sure that the roof structure is adequate to support the weight involved. (See Electrical & Physical Tables in this manual.) **THIS IS VERY IMPORTANT AND THE INSTALLER'S RESPONSIBILITY.**
2. For rigging and roofcurb details, see Figures 9, 10, 11 and 12.
3. The location of the unit on the roof should be such as to provide proper access for inspection and servicing.
4. Remove compressor shipping supports (if so equipped) after installation.

**IMPORTANT:** If unit will not be put into service immediately, block off supply and return air openings to prevent excessive condensation.

**FIGURE 7**  
COVER GASKET DETAIL FOR UNITS SHIPPED FOR DOWNFLOW APPLICATION  
BEING CONVERTED TO HORIZONTAL

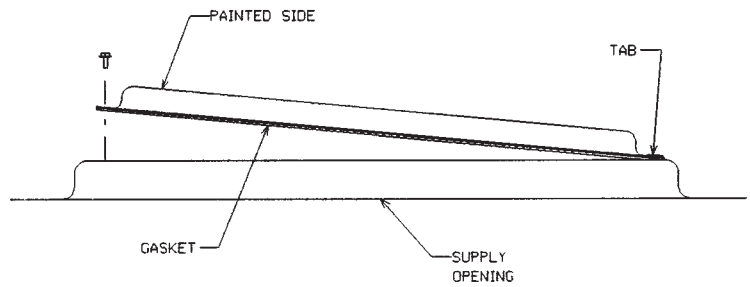

1631

**FIGURE 8**  
CLEARANCES

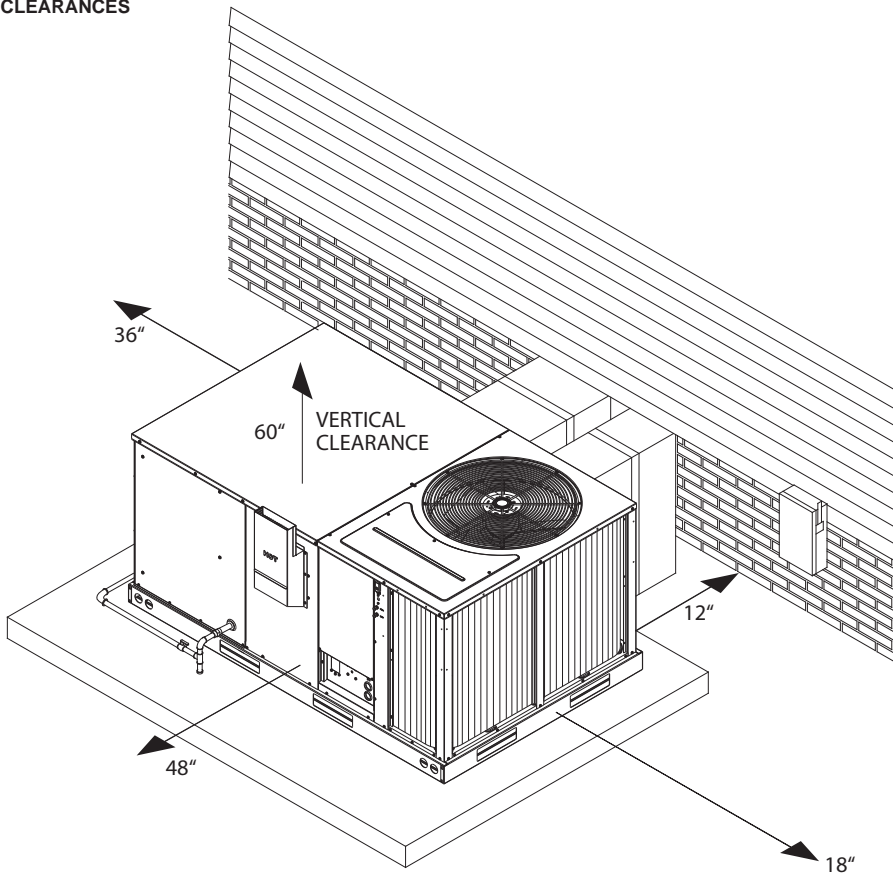

ST-A1141-13

Recommended Clearance	Location
48"	A - Front
18"	B - Condenser Coil
12"*	C - Duct Side
36"	D - Evaporator End
60"	E - Above

\*Without Economizer. 57 With Economizer

## G. DUCTWORK

The installing contractor should fabricate ductwork in accordance with local codes. Use industry manuals as a guide when sizing and designing the duct system. Contact Air Conditioning Contractors of America, 2800 Shirlington Road, Suite 300, Arlington, VA 22206, <http://www.acca.org>.

## **⚠ WARNING**

**DO NOT, UNDER ANY CIRCUMSTANCES, CONNECT RETURN DUCTWORK TO ANY OTHER HEAT PRODUCING DEVICE SUCH AS FIREPLACE INSERT, STOVE, ETC. UNAUTHORIZED USE OF SUCH DEVICES MAY RESULT IN FIRE, CARBON MONOXIDE POISONING, EXPLOSION, PERSONAL INJURY, PROPERTY DAMAGE OR DEATH.**

**FIGURE 9**  
FLAT ROOFTOP INSTALLATION, ATTIC OR DROP CEILING DISTRIBUTING SYSTEM. MOUNTED ON ROOFCURB. CURB MUST BE LEVEL.

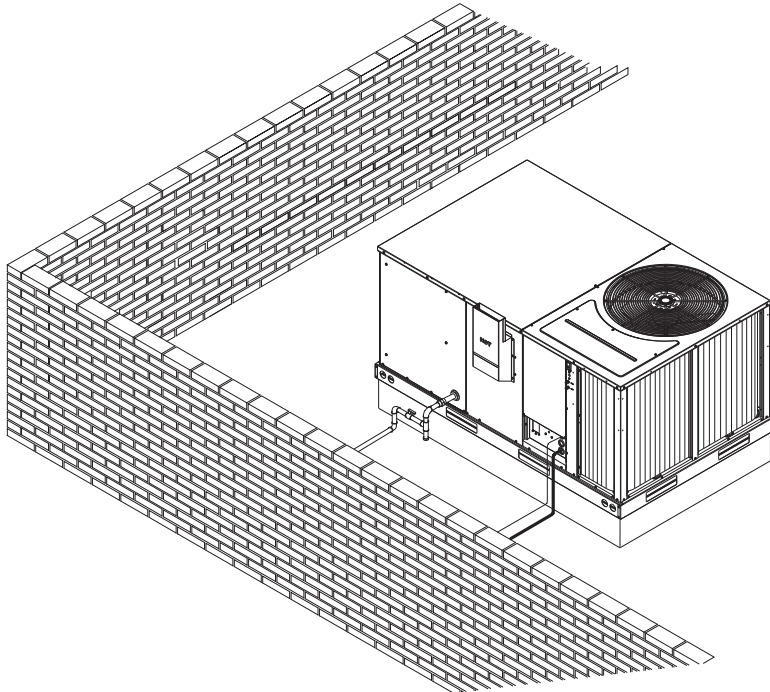

ST-A1141-10

Place the unit as close to the conditioned space as possible allowing clearances as indicated. Run ducts as directly as possible to supply and return outlets. Use of non-flammable weatherproof flexible connectors on both supply and return connections at unit to reduce noise transmission is recommended.

On ductwork exposed to outside temperature and humidity, use a minimum of 2" of insulation and a vapor barrier. Distribution system in attic, furred space or crawl space should be insulated with at least 2" of insulation. ½" to 1" thick insulation is usually sufficient for ductwork inside the air conditioned space.

Provide balancing dampers for each branch duct in the supply system. Properly support ductwork from the structure.

**IMPORTANT:** In the event that the return air ducts must be run through an "unconfined" space containing other fuel burning equipment, it is imperative that the user/homeowner must be informed against future changes in construction which might change this to a "confined space." Also, caution the user/homeowner against any future installation of additional equipment (such as power ventilators, clothes dryers, etc., within the existing unconfined and/or confined space which might create a negative pressure within the vicinity of other solid, liquid, or gas fueled appliances.

## **H. RETURN AIR**

### **⚠ WARNING**

**NEVER ALLOW PRODUCTS OF COMBUSTION OR THE FLUE PRODUCTS TO ENTER THE RETURN AIR DUCTWORK, OR THE CIRCULATING AIR SUPPLY. ALL RETURN DUCTWORK MUST BE ADEQUATELY SEALED AND SECURED TO THE FURNACE WITH SHEET METAL SCREWS, AND JOINTS TAPED. ALL OTHER DUCT JOINTS MUST BE SECURED WITH APPROVED CONNECTIONS AND SEALED AIRTIGHT.**

**FAILURE TO PREVENT PRODUCTS OF COMBUSTION FROM BEING CIRCULATED INTO THE LIVING SPACE CAN CREATE POTENTIALLY HAZARDOUS CONDITIONS, INCLUDING CARBON MONOXIDE POISONING THAT COULD RESULT IN PERSONAL INJURY OR DEATH.**

**FIGURE 10**  
**LIFTING DETAIL**

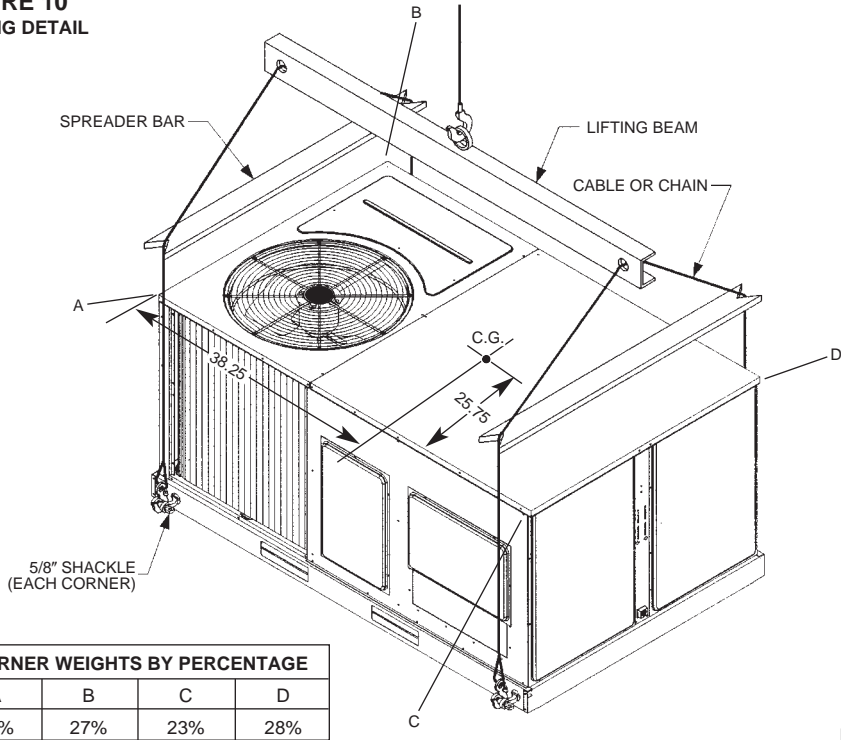

CORNER WEIGHTS BY PERCENTAGE			
A	B	C	D
22%	27%	23%	28%

I296

**FIGURE 11**  
**ROOFCURB**

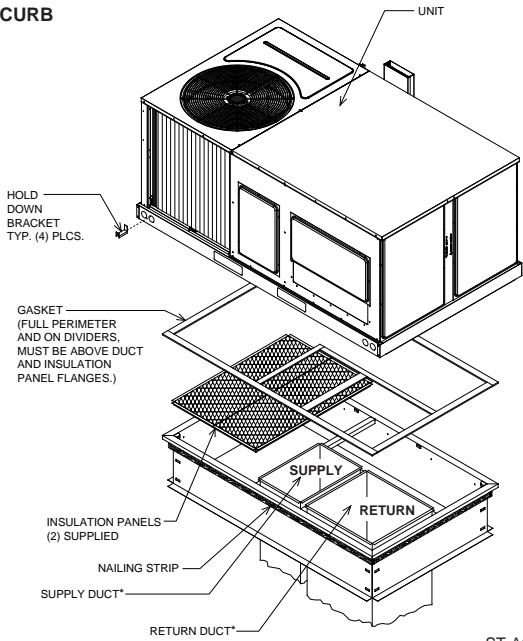

ST-A0801-19-01

**FIGURE 12**  
**ROOFCURB**

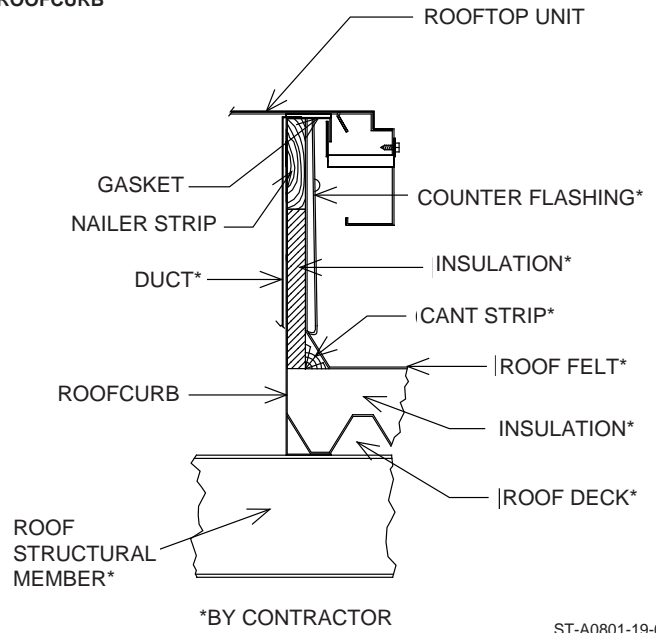

ST-A0801-19-01

# VIII. GAS SUPPLY, CONDENSATE DRAIN AND PIPING

## A. GAS CONNECTION

**IMPORTANT:** Connect this unit only to gas supplied by a commercial utility.

1. Install gas piping in accordance with local codes and regulations of the local utility company. In the absence of local codes, the installation must conform to the specifications of the National Fuel Gas Code, ANSI Z223.1 - latest edition.

**NOTE:** The use of flexible gas connectors is not recommended. If local codes allow the use of a corrugated stainless steel flexible gas appliance connector, always use a new listed connector. Do not use a connector which has previously serviced another gas appliance.

**NOTE:** The Commonwealth of Massachusetts requires the gas shut-off valve to be a T-handle gas cock.

2. Connect the gas line to the gas pipe inlet opening provided into the 1/2" inlet valve. See Figure 6 or 9 for typical piping.
3. Size the gas line to the furnace adequately to prevent undue pressure drop and never less than 1/2" nominal pipe size.
4. Install a drip leg or sediment trap in the gas supply line as close to the unit as possible.
5. Install an outside ground joint union to connect the gas supply to the control assembly at the burner tray.
6. Gas valves have been factory installed. Install a manual gas valve where local codes specify a shut-off valve outside the unit casing. (See Figure 13.)
7. Make sure piping is tight. **A pipe compound resistant to the action of liquefied petroleum gases must be used at all threaded pipe connections.**
8. **IMPORTANT:** Any additions, changes or conversions required for the furnace to satisfactorily meet the application should be made by a qualified installer, service agency or the gas supplier, using factory-specified or approved parts. In the commonwealth of Massachusetts, installation must be performed by a licensed plumber or gas fitter for appropriate fuel.

**IMPORTANT:** Disconnect the furnace and its individual shutoff valve from the gas supply piping during any pressure testing of that system at test pressures in excess of 1/2 pound per square inch gauge or isolate the system from the gas supply piping system by closing its individual manual shutoff valve during any pressure testing of this gas supply system at pressures equal to or less than 1/2 PSIG.

TO CHECK FOR GAS LEAKS, USE A SOAP AND WATER SOLUTION OR OTHER APPROVED METHOD. DO NOT USE AN OPEN FLAME.

### **WARNING**

**CHECK FOR LEAKS. THE USE OF AN OPEN FLAME CAN RESULT IN FIRE, EXPLOSION, PROPERTY DAMAGE, PERSONAL INJURY OR DEATH.**

**IMPORTANT:** Check the rating plate to make certain the appliance is equipped to burn the type of gas supplied. Care should be taken after installation of this equipment that the gas control valve not be subjected to high gas supply line pressure.

**FIGURE 13**  
SUGGESTED GAS PIPING

### ROOF OR GROUND LEVEL INSTALLATION

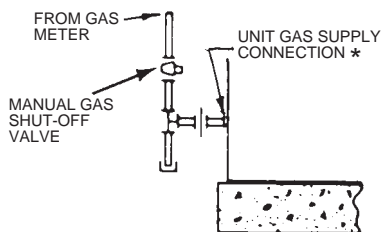

\*Factory supplied grommet must be utilized.

**TABLE 1**  
NATURAL GAS PIPE CAPACITY TABLE (CU. FT./HR.)

Nominal Iron Pipe Size, Inches	Equivalent Length of Pipe, Feet							
	10	20	30	40	50	60	70	80
1/2	132	92	73	63	56	50	46	43
3/4	278	190	152	130	115	105	96	90
1	520	350	285	245	215	195	180	170
1 1/4	1,050	730	590	500	440	400	370	350
1 1/2	1,600	1,100	890	760	670	610	560	530

In making gas connections, avoid strains as they may cause noise and damage the controls. Use a backup wrench on the valve to avoid damage.

The capacities of gas pipe of different diameters and lengths in cu. ft. per hr. with pressure drop of 0.3 in. and specific gravity of 0.60 (natural gas) are shown in Table 1.

After determining the pipe length, select the pipe size which will provide the minimum cubic feet per hour required for the gas input rating of the furnace. By formula:

$$\text{Cu. Ft. Per Hr. Required} = \frac{\text{Gas Input of Furnace (BTU/HR)}}{\text{Heating Value of Gas (BTU/FT}^3\text{)}}$$

The gas input of the furnace is marked on the furnace rating plate. The heating value of the gas (BTU/FT<sup>3</sup>) may be determined by consulting the local natural gas utility or the L.P. gas supplier.

## B. LP CONVERSION

### WARNING

**FACTORY FOR USE ON NATURAL GAS ONLY. CONVERSION TO LP GAS REQUIRES A SPECIAL KIT SUPPLIED BY THE DISTRIBUTOR OR MANUFACTURER. MAILING ADDRESSES ARE LISTED ON THE FURNACE RATING PLATE, PARTS LIST AND WARRANTY. FAILURE TO USE THE PROPER CONVERSION KIT CAN CAUSE FIRE, CARBON MONOXIDE POISONING, EXPLOSION, PERSONAL INJURY, PROPERTY DAMAGE OR DEATH.**

Convert the valve to use liquefied petroleum (LP) gas by replacing the pressure regulator spring with the conversion kit spring. This LP kit spring allows the regulator to maintain the proper manifold pressure for LP gas. The correct burner LP orifices are included in the kit. See Figure 14.

**IMPORTANT:** To remove the gas valve, remove the four screws securing the manifold pipe to the burner tray. Remove the manifold pipe with gas valve attached. See Figure 15.

**NOTE:** Order the correct LP conversion kit from the furnace manufacturer. **See Conversion Kit Index shipped with unit for proper LP kit number. Furnace conversion to LP gas must be performed by a qualified technician.**

## C. NOx MODELS

When converting units equipped with NOx inserts to LP gas, the stainless steel screen mesh inserts in the entrance of the tubular exchangers are not required to meet SCAQMD NOx emission levels. These inserts and 1/8" diameter retaining rod should be carefully removed before firing this furnace on LP gas. **IMPORTANT:** This furnace is not designed to operate on LP gas with the NOx inserts in place.

Step by step instructions on removing the NOx inserts and retaining rod are included in the Conversion Kit Installation Instructions.

**TABLE 2**  
**LP GAS PIPE CAPACITY TABLE (CU. FT./HR.)**

Maximum capacity of pipe in thousands of BTU per hour of undiluted liquefied petroleum gases (at 11 inches water column inlet pressure).  
(Based on a Pressure Drop of 0.5 Inch Water Column)

Nominal Iron Pipe Size, Inches	Length of Pipe, Feet											
	10	20	30	40	50	60	70	80	90	100	125	150
1/2	275	189	152	129	114	103	96	89	83	78	69	63
3/4	567	393	315	267	237	217	196	182	173	162	146	132
1	1,071	732	590	504	448	409	378	346	322	307	275	252
1-1/4	2,205	1,496	1,212	1,039	913	834	771	724	677	630	567	511
1-1/2	3,307	2,299	1,858	1,559	1,417	1,275	1,181	1,086	1,023	976	866	787
2	6,221	4,331	3,465	2,992	2,646	2,394	2,205	2,047	1,921	1,811	1,606	1,496

Example (LP): Input BTU requirement of unit, 150,000  
Equivalent length of pipe, 60 ft. = 3/4" IPS required.

FIGURE 14



FIGURE 15



MANIFOLD PIPE

### D. ADJUSTING OR CHECKING FURNACE INPUT

- Natural Gas Line Pressure 5" - 10.5" W.C.
- LP Gas Line Pressure 11" - 13" W.C.
- Natural Gas Manifold Pressure 3.5" W.C
- LP Gas Manifold Pressure - 10" W.C.

Supply and manifold pressure taps are located on the gas valve body 1/8" N.P.T. and on the manifold.

Use a properly calibrated manometer gauge for accurate gas pressure readings.

Only small variations in the gas flow should be made by means of the pressure regulator adjustment. Furnaces functioning on LP gas must be set by means of the tank or branch supply regulators. The furnace manifold pressure should be set at 10" W.C. at the gas control valve.

To adjust the pressure regulator, remove the regulator cap and turn the adjustment screw clockwise to increase pressure or counterclockwise to decrease pressure. **Then replace the regulator cap securely.**

Any necessary major changes in the gas flow rate should be made by changing the size of the burner orifices. To change orifice spuds, shut off the manual main gas valve and remove the gas manifold.

For elevations up to 2,000 feet, rating plate input ratings apply. For high altitudes (elevations over 2,000 ft.), see conversion kit index 92-21519-XX for derating and orifice spud sizes.

**Check of input is important to prevent over-firing of the furnace beyond its design-rated input. NEVER SET INPUT ABOVE THAT SHOWN ON THE RATING PLATE. Use the following table or formula to determine input rate.**

$$\text{Cu. Ft. Per Hr. Required} = \frac{\text{Heating Value of Gas (BTU/Cu. Ft.)} \times 3600}{\text{Time in Seconds (for 1 Cu. Ft.) of Gas}}$$

Start the furnace and measure the time required to burn one cubic foot of gas. Prior to checking the furnace input, make certain that all other gas appliances are shut off, with the exception of pilot burners. Time the meter with only the furnace in operation.

**IMPORTANT NOTE FOR ALTITUDES ABOVE 2,000 FEET (610 METERS):** The main burner orifices in your furnace and in these kits are sized for the nameplate input and intended for installations at elevations up to 2,000 feet in the USA or Canada, or for elevations of 2,000 - 4,500 feet (610 -1,373 meters) in Canada if the unit has been derated at the factory. For elevations above 2,000 feet (610 meters) IN THE USA ONLY (see ANSI-Z223.1), the burner orifices must be sized to reduce the input 4% for each 1,000 feet (305 meters) above sea level.

**TABLE 3**

METER TIME IN MINUTES AND SECONDS FOR NORMAL INPUT RATING OF FURNACES EQUIPPED FOR NATURAL OR LP GAS											
INPUT BTU/HR	METER SIZE CU. FT.	HEATING VALUE OF GAS BTU PER CU. FT.									
		900		1000		1040		1100		2500	
		MIN.	SEC.	MIN.	SEC.	MIN.	SEC.	MIN.	SEC.	MIN.	SEC.
40,000	ONE TEN	1	21	1	30	1	34	1	39	3	45
		13	30	15	0	15	36	16	30	37	30
60,000	ONE TEN	0	54	1	0	1	3	1	6	2	30
		9	0	10	0	10	24	11	0	25	0
80,000	ONE TEN	0	41	0	45	0	47	0	50	1	53
		6	45	7	30	7	48	8	15	18	45
100,000	ONE TEN	0	33	0	36	0	38	0	40	1	30
		5	24	6	0	6	15	6	36	15	0

**FIGURE 16**  
CONDENSATE DRAIN

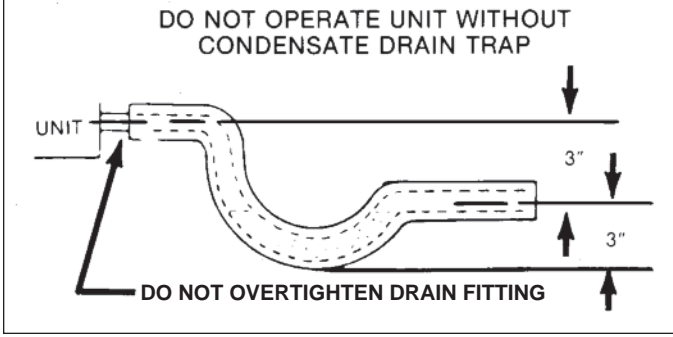

**TABLE 4**  
ALTERNATE METHOD FOR CANADIAN HIGH-ALTITUDE DERATE NATURAL GAS

Altitude	Input	Output	Orifice Size	Manifold Pressure
0'-2000'	40,000	32,000	#45	3.5" W.C.
	60,000	48,000		
	80,000	64,000		
	100,000	80,000		
	120,000	96,000		
	135,000	108,000	#43	
2001'-4500'	36,000	28,800	#45	2.9" W.C.
	54,000	43,200		
	72,000	57,600		
	90,000	72,000		
	108,000	86,400		
	121,500	97,200	#43	

**LP GAS**

Altitude	Input	Output	Orifice Size	Manifold Pressure
0'-2000'	40,000	32,000	#55	10" W.C.
	60,000	48,000		
	80,000	64,000		
	100,000	80,000		
	120,000	96,000		
	135,000	108,000		
2001'-4500'	36,000	28,800	#55	8.1" W.C.
	54,000	43,200		
	72,000	57,600		
	90,000	72,000		
	108,000	86,400		
	121,500	97,200		

**FIGURE 17**  
MANIFOLD PRESSURE CHANGE LABEL

The manifold pressure of this appliance has been field adjusted to obtain the correct input rating for installation at altitudes between 2,000 feet and 4,500 feet elevation.

La pression du distributeur d'alimentation de cet appareil a été ajustée sur les lieux afin d'obtenir la bonne puissance d'entrée pour une installation entre 2000 et 4500 pieds d'altitude.

**Alternate Method for Canadian High-Altitude Derate for Residential and Light Commercial Gas/Electric Package Units**

In Canada, unless an orifice change is specifically mandated by local codes, an alternate method of altitude deration through a reduction in manifold pressure is acceptable as described in Table 4.

The information in Table 1 is based on a heating value of 1000 BTU per cubic feet of natural gas, and 2500 BTU per cubic feet of LP gas.

**Important: Actual input rates must be measured on-site with manifold pressure adjustment to ensure that an actual 10% reduction in input rate is achieved.**

Once this field adjustment has been made, the label shown in Figure 17 must be affixed in a conspicuous location on the front of the furnace cabinet.

**NOTE:** This label is supplied in the information package shipped with each unit.



**FIGURE 18**  
RECOMMENDED BRANCH CIRCUIT DISCONNECT LOCATION

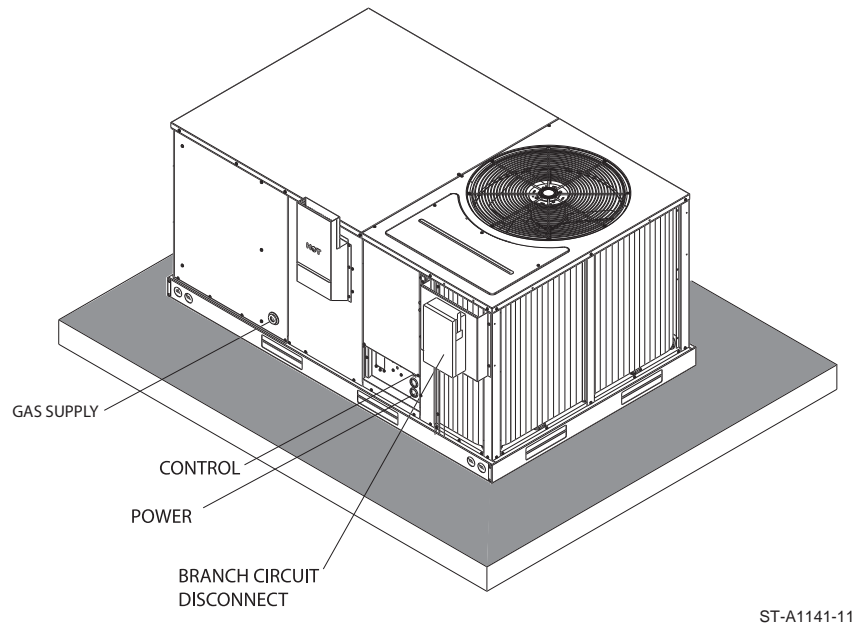

**TABLE 5**  
BRANCH CIRCUIT COPPER WIRE SIZE  
(Based on 1% Voltage Drop)\*

200	6	4	4	4	3	3	2	2
150	8	6	6	4	4	4	3	3
100	10	8	8	6	6	6	4	4
50	14	12	10	10	8	8	6	6
	15	20	25	30	35	40	45	50

**BRANCH CIRCUIT AMPACITY**

**SUPPLY WIRE  
LENGTH-FEET**

\*Taken from National Electric Code

**E. CONDENSATE DRAIN**

The condensate drain connection of the evaporator is threaded 3/4" nominal P.V.C. pipe. **IMPORTANT:** Install a condensate trap to ensure proper condensate drainage. See Figure 16.

**IX. WIRING**

**A. POWER SUPPLY**

**⚠ WARNING**

**TURN OFF THE MAIN ELECTRICAL POWER AT THE BRANCH CIRCUIT DISCONNECT CLOSEST TO THE UNIT BEFORE ATTEMPTING ANY WIRING. FAILURE TO DO SO CAN CAUSE ELECTRICAL SHOCK RESULTING IN PERSONAL INJURY OR DEATH.**

- All wiring should be made in accordance with the National Electrical Code.** Consult the local power company to determine the availability of sufficient power to operate the unit. Check the voltage at power supply to make sure it corresponds to the unit's RATED VOLTAGE REQUIREMENT. Install a branch circuit disconnect near the rooftop, in accordance with the N.E.C., C.E.C. or local codes. A bracket is provided with the unit for mounting of the disconnect. See Figure 17.
- It is important that proper electrical power is available at the unit. Voltage should not vary more than 10% from that stamped on the unit nameplate. On three phase units, phases must be balanced within 3%.
- For branch circuit wiring (main power supply to unit disconnect), the minimum wire size for the length of run can be determined from Table 3 using the circuit ampacity found on the unit rating plate. Use the smallest wire size allowable in Table 4 from the unit disconnect to unit.

**TABLE 6**

AWG Copper Wire Size	AWG Aluminum Wire Size	Connector Type and Size (or equivalent)
#12	#10	T & B Wire Nut PT2
#10	# 8	T & B Wire Nut PT3
# 8	# 6	Sherman Split Bolt TSP6
# 6	# 4	Sherman Split Bolt TSP4
# 4	# 2	Sherman Split Bolt TSP2

**FIGURE 19**

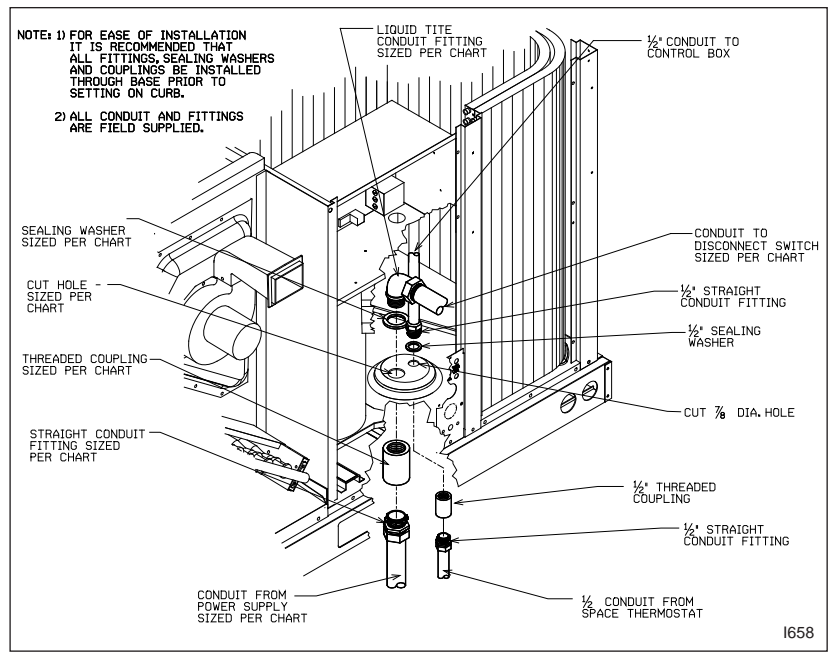

**FIGURE 20  
TYPICAL THERMOSTAT WIRING**

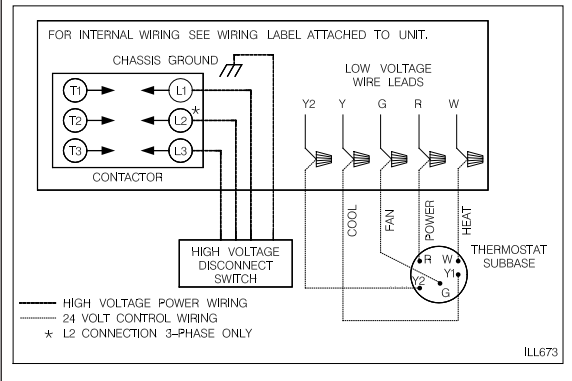

	WIRE SIZE, AWG											
	14	12	10	8	6	4	3	2	1	0	00	000
<b>CONDUIT SIZE</b>	1/2"	1/2"	1/2"	3/4"	1"	1"	1-1/4"	1-1/4"	1-1/2"	1-1/2"	2"	2"
<b>HOLE SIZE</b>	7/8"	7/8"	7/8"	1-31/32"	1-23/64"	1-23/64"	1-23/32"	1-23/32"	1-31/32"	1-31/32"	2-15/32"	2-15/32"

- NOTES:**
1. DETERMINE REQUIRED WIRE SIZE FROM MINIMUM CIRCUIT AMPACITY SHOWN IN INSTALLATION & OPERATING INSTRUCTION.
  2. BOTTOM POWER ENTRY WILL NOT ACCOMMODATE WIRE LARGER THAN #2 AWG (SHADED AREA).

**NOTE:** A bracket is provided with the unit for mounting the branch circuit disconnect to the unit. This is the recommended location for the disconnect. See Figure 17.

4. For through the base wiring entry reference **Figure 18**. All fittings and conduit are field supplied for this application. Reference the chart with **Figure 18** for proper hole and conduit size.

**NOTES:**

1. Wire size based on 60°C rated wire insulation and 30°C Ambient Temp. (86°F).
2. For more than 3 conductors in a raceway or cable, see the N.E.C. for derating the ampacity of each conductor.

When installed, the unit must be electrically grounded in accordance with local codes or, in the absence of local codes, with the National Electrical Code, **ANSI/NFPA 70**, if an external electrical source is utilized.

**IMPORTANT: THIS UNIT IS APPROVED FOR USE WITH COPPER CONDUCTORS ONLY CONNECTED TO UNIT CONTACTOR.**

**WARRANTY MAY BE JEOPARDIZED IF ALUMINUM WIRE IS CONNECTED TO UNIT CONTACTOR.**

**Special instructions apply for power wiring with aluminum conductors: Warranty is void if connections are not made per instructions.**

Attach a length (6" or more) of recommended size copper wire to the unit contactor terminals L1 and L3 for single phase, L1, L2 and L3 for three phase.

Select the equivalent aluminum wire size from Table 6:

Splice copper wire pigtails to aluminum wire with U.L. recognized connectors for copper-aluminum splices. Please exercise the following instructions very carefully to obtain a positive and lasting connection:

1. Strip insulation from aluminum conductor.
2. Coat the stripped end of the aluminum wire with the recommended inhibitor, and wire brush the aluminum surface through inhibitor. INHIBITORS: Brundy-Pentex "A"; Alcoa-No. 2EJC; T & B-KPOR Shield.
3. Clean and recoat aluminum conductor with inhibitor.

**TABLE 7**

FIELD WIRE SIZE FOR 24 VOLT THERMOSTAT CIRCUITS						
Thermostat Load - Amps	SOLID COPPER WIRE - AWG.					
	3.0	16	14	12	10	10
2.5	16	14	12	12	12	10
2.0	18	16	14	12	12	10
	50	100	150	200	250	300
	<b>Length of Run – Feet (1)</b>					

(1) The total wire length is the distance from the furnace to the thermostat and back to the furnace.

NOTE: DO NOT USE CONTROL WIRING SMALLER THAN NO. 18 AWG.

4. Make the splice using the wire nuts or split bolt connectors shown in Table 6.
5. Coat the entire connection with inhibitor and wrap with electrical insulating tape.

## B. HOOK-UP

To wire unit, refer to the following hook-up diagram.

Refer to Figures 3 and 18 for location of wiring entrances.

Wiring to be done in the field between the unit and devices not attached to the unit, or between separate devices which are field installed and located, shall conform with the temperature limitation for Type T wire [63°F rise (35°C)] when installed in accordance with the manufacturer's instructions.

## C. INTERNAL WIRING

**IMPORTANT:** Some single phase units are equipped with a single pole contactor. Caution must be exercised when servicing as only one leg of the power supply is broken with the contactor.

Some models are equipped with electronically commutated blower motors which are constantly energized, unless the main unit disconnect is in the off position.

A diagram of the internal wiring of this unit is located under the electrical box cover and this manual. If any of the original wire as supplied with the appliance must be replaced, the wire gauge and insulation must be same as original wiring.

Transformer is factory wired for 230 volts on 208/230 volt models and must be changed for 208 volt applications. See unit wiring diagram for 208 volt wiring.

## D. THERMOSTAT

The room thermostat must be compatible with the spark ignition control on the unit. Generally, all thermostats that are not of the "current robbing" type are compatible with the integrated furnace control. The low voltage wiring should be sized as shown in Table 6.

Install the room thermostat in accordance with the instruction sheet packed in the box with the thermostat. Run the thermostat lead wires inside the compressor access panel compartment and connect to low voltage terminals as shown on the wiring diagram. Never install the thermostat on an outside wall or where it will be influenced by drafts, concealed hot or cold water pipes or ducts, lighting fixtures, radiation from fireplace, sun rays, lamps, televisions, radios or air streams from registers. Refer to instructions packed with the thermostat for "heater" selection or adjustment.

The following are the recommended thermostats available through the manufacturer to be used:

W/O Economizer	W/Economizer
(-)HC-TST101GESS	(-)HC-TST103UNMS
(-)HC-TST103UNMS	(-)HC-TST203UNMS
(-)HC-TST201GESS	(-)HC-TST302UNMS
(-)HC-TST203UNMS	(-)HC-TST303UNMS
(-)HC-TST301GESS	(-)HC-TST304UNMS
(-)HC-TST302UNMS	
(-)HC-TST303UNMS	
(-)HC-TST304UNMS	

# X. FURNACE SECTION CONTROLS AND IGNITION SYSTEM

## NORMAL FURNACE OPERATING SEQUENCE

This unit is equipped with an integrated direct spark ignition control.

1. The thermostat calls for heat.
2. The control board will run a self check to verify that the limit control and manual reset overtemperature control are closed and that the pressure switch is open.
3. Upon closure of the pressure switch, the control board energizes the induced draft blower for a 15 second prepurge.
4. After the 15 second prepurge, the gas valve opens and the spark is initiated for 7 second trial for ignition.
5. Burners ignite and flame sensor proves all burners have lit.
6. The circulating air blower is energized after 30 seconds.
7. The control board enters a normal operation loop in which all safety controls are monitored continuously.
8. Thermostat is satisfied and opens.
9. The gas valve is de-energized and closes, shutting down the burner flame.
10. The control board will de-energize the inducer after a five second post purge.
11. The circulating air blower is de-energized after 90 seconds.

The integrated control is a three ignition system.

After a total of three cycles without sensing main burner flame, the system goes into a 100% lockout mode. After one hour, the ignition control repeats the prepurge and ignition cycles for 3 tries and then go into 100% lockout mode again. It continues this sequence of cycles and lockout each hour until ignition is successful or power is interrupted. During the lockout mode, neither the ignitor or gas valve will be energized until the system is reset by turning the thermostat to the "OFF" position or interrupting the electrical power to the unit for 3 seconds or longer. The induced draft blower and main burner will shut off when the thermostat is satisfied.

The circulating air blower will start and run on the heating speed if the thermostat fan switch is in the "ON" position.

The integrated furnace control is equipped with diagnostic LED. The LED is lit continuously when there is power to the control, with or without a call for heat. If the LED is not lit, there is either no power to the control or there is an internal component failure within the control, and the control should be replaced.

If the control detects the following failures, the LED will flash on for approximately 1/4 second, then off for 3/4 second for designated failure detections.

- 1 Flash: Failed to detect flame within the three tries for ignition.
- 2 Flash: Pressure switch or induced draft blower problem detected.
- 3 Flash: High limit or auxiliary limit open.
- 4 Flash: Flame sensed and gas valve not energized or flame sensed with no "W" signal.
- 5 Flash: Overtemperature switch open.

## OPERATING INSTRUCTIONS

This appliance is equipped with integrated furnace control. This device lights the main burners each time the room thermostat (closes) calls for heat. See operating instructions on the back of the furnace/controls access panel.

### **WARNING**

**DO NOT ATTEMPT TO MANUALLY LIGHT THIS FURNACE WITH A MATCH OR ANY OPEN FLAME. ATTEMPTING TO DO SO CAN CAUSE AN EXPLOSION OR FIRE RESULTING IN PROPERTY DAMAGE, PERSONAL INJURY OR DEATH.**

### **TO START THE FURNACE**

1. STOP! Read the safety information on the Operating Instructions label located on this appliance.

### **WARNING**

**IF YOU DO NOT FOLLOW THESE INSTRUCTIONS EXACTLY, A FIRE OR EXPLOSION MAY RESULT CAUSING PROPERTY DAMAGE, PERSONAL INJURY OR LOSS OF LIFE.**

2. Set the thermostat to its lowest setting.
3. Turn off all electric power to the appliance.
4. This appliance does not have a pilot. It is equipped with an ignition device which automatically lights the burner. Do NOT try to light the burner by hand.

5. Remove control door/access panel.
6. Move switch to the "OFF" position.
7. Wait five (5) minutes to clear out any gas. Then smell for gas, including near the floor. If you smell gas, STOP!
  - Do not try to light any appliance.
  - Do not touch any electric switch; do not use any phone in your building.
  - Immediately call your gas supplier from a neighbor's phone. Follow the gas supplier's instructions.
  - If you cannot reach your gas supplier, call the fire department.
 If you don't smell gas, go to the next step.
8. Move "OFF" position to "ON" position.
9. Replace the control door.
10. Turn on all electric power to the appliance.
11. Set the thermostat to the desired setting.
12. If the appliance will not operate, follow the instructions below on how to shut down the furnace.

## **WARNING**

**THE SPARK IGNITOR AND IGNITION LEAD FROM THE IGNITION CONTROL ARE HIGH VOLTAGE. KEEP HANDS OR TOOLS AWAY TO PREVENT ELECTRICAL SHOCK. SHUT OFF ELECTRICAL POWER BEFORE SERVICING ANY OF THE CONTROLS. FAILURE TO ADHERE TO THIS WARNING CAN RESULT IN PERSONAL INJURY OR DEATH.**

The initial start-up on a new installation may require the control system to be energized for some time until air has bled through the system and fuel gas is available at the burners.

### **TO SHUT DOWN FURNACE**

1. Set the thermostat to the lowest setting.
2. Turn off all electric power to the appliance if service is to be performed.
3. Remove control door.
4. Move switch to the "OFF" position.
5. Replace control door.

## **WARNING**

**SHOULD OVERHEATING OCCUR OR THE GAS SUPPLY FAIL TO SHUT OFF, SHUT OFF THE MANUAL GAS VALVE TO THE APPLIANCE BEFORE SHUTTING OFF THE ELECTRICAL SUPPLY. FAILURE TO DO SO CAN RESULT IN AN EXPLOSION OR FIRE CAUSING PROPERTY DAMAGE, SEVERE PERSONAL INJURY OR DEATH!**

## **BURNERS**

Burners for these units have been designed so that field adjustment is not required. Burners are tray-mounted and accessible for easy cleaning when required.

## **MANUAL RESET OVERTEMPERATURE CONTROL**

Two manual reset overtemperature controls (one on 80,000 BTUH) are located on the burner shield. These devices sense blockage in the heat exchanger or insufficient combustion air. This shuts off the main burners if excessive temperatures occur in the burner compartment.

Operation of this control indicates an abnormal condition. Therefore, the unit should be examined by a qualified installer, service agency, or the gas supplier before being placed back into operation.

## **WARNING**

**DO NOT JUMPER THIS DEVICE! DO NOT reset the overtemperature control without taking corrective action to assure that an adequate supply of combustion air is maintained under all conditions of operation. Failure to do so can result in carbon monoxide poisoning or death. Replace this control only with the identical replacement part.**

## **PRESSURE SWITCH**

This furnace has a pressure switch for sensing a blocked exhaust or a failed induced draft blower. It is normally open and closes when the induced draft blower starts, indicating air flow through the combustion chamber.

## LIMIT CONTROL

The supply air high temperature limit cut-off is set at the factory and cannot be adjusted. It is calibrated to prevent the air temperature leaving the furnace from exceeding the maximum outlet air temperature.

### **WARNING**

**DO NOT JUMPER THIS DEVICE! DOING SO CAN CAUSE A FIRE OR EXPLOSION RESULTING IN PROPERTY DAMAGE, PERSONAL INJURY OR DEATH.**

***IMPORTANT:** Replace this control only with the identical replacement part.*

## XI. SYSTEM OPERATING INFORMATION

### ADVISE THE CUSTOMER

1. Change the air filters regularly. The heating system operates better, more efficiently and more economically.
2. Arrange the furniture and drapes so that the supply air registers and the return air grilles are unobstructed.
3. Close doors and windows. This reduces the heating and cooling load on the system.
4. Avoid excessive use of exhaust fans.
5. Do not permit the heat generated by television, lamps or radios to influence the thermostat operation.
6. Except for the mounting platform, keep all combustible articles three feet from the unit and exhaust system.
7. ***IMPORTANT:** Replace all blower doors and compartment cover after servicing the unit. Do not operate the unit without all panels and doors securely in place.*
8. Do not allow snow or other debris to accumulate in the vicinity of the appliance.

### FURNACE SECTION MAINTENANCE

The unit's furnace should operate for many years without excessive scale build-up in flue passageways; however, it is recommended that a qualified installer, service agency, or the gas supplier annually inspect the flue passageways, the exhaust system and the burners for continued safe operation, paying particular attention to deterioration from corrosion or other sources.

If during inspection the flue passageways and exhaust system are determined to require cleaning, the following procedures should be followed (**by a qualified installer, service agency, or gas supplier**):

1. **Turn off the electrical power to the unit and set the thermostat to the lowest temperature.**
2. **Shut off the gas supply to the unit either at the meter or at manual valve in the supply piping.**

### **WARNING**

**LABEL ALL WIRES PRIOR TO DISCONNECTION WHEN SERVICING CONTROLS. WIRING ERRORS CAN CAUSE IMPROPER AND DANGEROUS OPERATION RESULTING IN FIRE, ELECTRICAL SHOCK, PROPERTY DAMAGE, PERSONAL INJURY OR DEATH.**

3. Remove the furnace controls access panel and the control box cover.
4. Disconnect the gas supply piping from the gas valve.
5. Disconnect the wiring to the induced draft blower motor, gas valve, flame sensor, and flame roll-out control, and ignitor cable. **Mark all wires disconnected for proper reconnection.**
6. Remove the screws (4) connecting the burner tray to the heat exchanger mounting panel.
7. Remove the burner tray and the manifold assembly from the unit.
8. Remove the screws (5) connecting the induced draft blower to the collector box and screws (18) connecting the collector box to the heat exchanger center panel. Remove the induced draft blower and the collector box from the unit.
9. Remove the screws (3) connecting the divider plate to the heat exchanger center panel.
10. Remove the turbulators from inside the heat exchangers by inserting the blade of a screwdriver under the locking tabs. Pop the tabs out of the expanded grooves of the heat exchanger. Slide the turbulators out of the heat exchangers.

11. Direct a water hose into the outlet of the heat exchanger top. Flush the inside of each heat exchanger tube with water. Blow out each tube with air to remove excessive moisture.
12. Reassemble (steps 1 through 10 in reverse order). **Be careful not to strip out the screw holes used to mount the collector box and inducer blower. Replace inducer blower gasket and collector box gasket with factory replacements if damaged.**

### **WARNING**

**HOLES IN THE EXHAUST TRANSITION OR HEAT EXCHANGER CAN CAUSE TOXIC FUMES TO ENTER THE HOME. THE EXHAUST TRANSITION OR HEAT EXCHANGER MUST BE REPLACED IF THEY HAVE HOLES OR CRACKS IN THEM. FAILURE TO DO SO CAN CAUSE CARBON MONOXIDE POISONING RESULTING IN PERSONAL INJURY OR DEATH.**

The manufacturer recommends that a qualified installer, service agency or the gas supplier visually inspect the burner flames for the desired flame appearance at the beginning of the heating season and approximately midway in heating season.

The manufacturer also recommends that a qualified installer, service agency or the gas supplier clean the flame sensor with steel wool at the beginning of the heating season.

### **WARNING**

**DISCONNECT MAIN ELECTRICAL POWER TO THE UNIT BEFORE ATTEMPTING MAINTENANCE. FAILURE TO DO SO MAY RESULT IN ELECTRICAL SHOCK OR SEVERE PERSONAL INJURY OR DEATH.**

## **LUBRICATION**

**IMPORTANT: DO NOT** attempt to lubricate the bearings on the blower motor or the induced draft blower motor. Addition of lubricants can reduce the motor life and void the warranty.

The blower motor and induced draft blower motor are prelubricated by the manufacturer and do not require further attention.

A qualified installer, service agency or the gas supplier must periodically clean the motors to prevent the possibility of overheating due to an accumulation of dust and dirt on the windings or on the motor exterior. And, as suggested elsewhere in these instructions, the air filters should be kept clean because dirty filters can restrict air flow and the motor depends upon sufficient air flowing across and through it to prevent overheating.

## **COOLING SECTION MAINTENANCE**

### **WARNING**

**DISCONNECT MAIN ELECTRICAL POWER TO THE UNIT BEFORE ATTEMPTING MAINTENANCE. FAILURE TO DO SO CAN CAUSE ELECTRICAL SHOCK RESULTING IN SEVERE PERSONAL INJURY OR DEATH.**

It is recommended that at the beginning of each cooling season a qualified installer or service agency inspect and clean the cooling section of this unit. The following areas should be addressed: evaporator coil, condenser coil, condenser fan motor and venturi area.

#### **To inspect the evaporator coil:**

1. Remove the filter access panel and the blower/evaporator coil access panel. Remove the filters.

### **WARNING**

**LABEL ALL WIRES PRIOR TO DISCONNECTION WHEN SERVICING THE UNIT. WIRING ERRORS CAN CAUSE IMPROPER AND DANGEROUS OPERATION RESULTING IN FIRE, ELECTRICAL SHOCK, PROPERTY DAMAGE, SEVERE PERSONAL INJURY OR DEATH.**

2. Shine a flashlight on the evaporator coil (both sides) and inspect for accumulation of lint, insulation, etc.
3. If coil requires cleaning, follow the steps shown below.

#### **Cleaning Evaporator Coil**

1. The coil should be cleaned when it is dry. If the coil is coated with dirt or lint, vacuum it with a soft brush attachment. Be careful not to bend the coil fins.

2. If the coil is coated with oil or grease, clean it with a mild detergent-and-water solution. Rinse the coil thoroughly with water. **IMPORTANT:** Do not use excessive water pressure. Excessive water pressure can bend the fins and tubing of the coil and lead to inadequate unit performance. Be careful not to splash water excessively into unit.
3. Inspect the drain pan and condensate drain at the same time the evaporator coil is checked. Clean the drain pan by flushing with water and removing any matters of obstructions which may be present.
4. Go to next section for cleaning the condenser coil.

#### **Cleaning Condenser Coil, Condenser Fan, Circulation Air Blower and Venturi**

1. Remove the compressor access panel. Disconnect the wires to the condenser fan motor in the control box (see wiring diagram). Remove the wires from the opening in the bottom of the control box.
2. Remove the screws securing the condenser top panel and remove the panel with condenser fan motor and grille attached.
3. The coil should be cleaned when it is dry. If the coil is coated with dirt or lint, vacuum it with a soft brush attachment. Be careful not to bend the coil fins.
4. If the coil is coated with oil or grease, clean it with a mild detergent-and-water solution. Rinse the coil thoroughly with water. **IMPORTANT:** Do not use excessive water pressure. Excessive water pressure can bend the fins and tubing of the coil and lead to inadequate unit performance. Be careful not to splash water excessively into unit.
5. The venturi should also be inspected for items of obstruction such as collections of grass, dirt or spider webs. Remove any that are present.
6. Inspect the circulating air blower wheel and motor for accumulation of lint, dirt or other obstruction and clean it necessary. Inspect the blower motor mounts and the blower housing for loose mounts or other damage. Repair or replace if necessary.

#### **Re-assembly**

1. Place the condenser top panel back on the unit and replace all screws.
2. Run the fan motor wires through the hole in the bottom of the control box. Reconnect fan motor wires per the wiring diagram attached to the back of the cover.
3. Replace the filter and blower/evaporator coil access panels.
4. Replace the control box cover and controls access panel.
5. Restore electrical power to the unit and check for proper operation, especially the condenser fan motor.

### **REPLACEMENT PARTS**

Contact your local distributor for a complete parts list.

### **TROUBLESHOOTING**

Refer to Troubleshooting Chart included in this manual.

### **WIRING DIAGRAMS**

Refer to the appropriate wiring diagram included in this manual.

### **CHARGING**

Refer to the appropriate charge chart included in this manual.



# XII. GENERAL DATA - RKKL MODELS

## NOMINAL SIZES 6 TON [21.1 kW]

Model RKKL - Series	B072CL10E	B072CL13E	B072CM10E	B072CM13E
<b>Cooling Performance<sup>1</sup></b>				<b>Continued -&gt;</b>
Gross Cooling Capacity Btu [kW]	73,000 [21.39]	73,000 [21.39]	73,000 [21.39]	73,000 [21.39]
EER/SEER <sup>2</sup>	11.2/NA	11.2/NA	11.2/NA	11.2/NA
Nominal CFM/ARI Rated CFM [L/s]	2400/2050 [1133/967]	2400/2050 [1133/967]	2400/2050 [1133/967]	2400/2050 [1133/967]
ARI Net Cooling Capacity Btu [kW]	70,000 [20.51]	70,000 [20.51]	70,000 [20.51]	70,000 [20.51]
Net Sensible Capacity Btu [kW]	49,700 [14.56]	49,700 [14.56]	49,700 [14.56]	49,700 [14.56]
Net Latent Capacity Btu [kW]	20,300 [5.95]	20,300 [5.95]	20,300 [5.95]	20,300 [5.95]
Integrated Part Load Value <sup>3</sup>	N/A	N/A	N/A	N/A
Net System Power kW	6.21	6.21	6.21	6.21
<b>Heating Performance (Gas)<sup>4</sup></b>				
Heating Performance (Gas) <sup>4</sup>	100,000 [29.3]	135,000 [39.55]	100,000 [29.3]	135,000 [39.55]
Heating Performance (Gas) <sup>4</sup>	81,000 [23.73]	109,400 [32.05]	81,000 [23.73]	109,400 [32.05]
Temperature Rise Range °F [°C]	20-50 [11.1/27.8]	30-60 [16.7/33.3]	20-50 [11.1/27.8]	30-60 [16.7/33.3]
Steady State Efficiency (%)	81	81	81	81
No. Burners	5	6	5	6
No. Stages	1	1	1	1
Gas Connection Pipe Size in. [mm]	0.5 [12.7]	0.5 [12.7]	0.5 [12.7]	0.5 [12.7]
<b>Compressor</b>				
No./Type	1/Scroll	1/Scroll	1/Scroll	1/Scroll
<b>Outdoor Sound Rating (dB)<sup>5</sup></b>	83	83	83	83
<b>Outdoor Coil - Fin Type</b>	Louvered	Louvered	Louvered	Louvered
Tube Type	Rifled	Rifled	Rifled	Rifled
Tube Size in. [mm] OD	0.375 [9.5]	0.375 [9.5]	0.375 [9.5]	0.375 [9.5]
Face Area sq. ft. [sq. m]	16.56 [1.54]	16.56 [1.54]	16.56 [1.54]	16.56 [1.54]
Rows / FPI [FPcm]	2 / 22 [9]	2 / 22 [9]	2 / 22 [9]	2 / 22 [9]
<b>Indoor Coil - Fin Type</b>	Corrugated	Corrugated	Corrugated	Corrugated
Tube Type	Rifled	Rifled	Rifled	Rifled
Tube Size in. [mm]	0.375 [9.5]	0.375 [9.5]	0.375 [9.5]	0.375 [9.5]
Face Area sq. ft. [sq. m]	6.5 [0.6]	6.5 [0.6]	6.5 [0.6]	6.5 [0.6]
Rows / FPI [FPcm]	4 / 12 [5]	4 / 12 [5]	4 / 12 [5]	4 / 12 [5]
Refrigerant Control	TX Valves	TX Valves	TX Valves	TX Valves
Drain Connection No./Size in. [mm]	1/1 [25.4]	1/1 [25.4]	1/1 [25.4]	1/1 [25.4]
<b>Outdoor Fan - Type</b>	Propeller	Propeller	Propeller	Propeller
No. Used/Diameter in. [mm]	1/24 [609.6]	1/24 [609.6]	1/24 [609.6]	1/24 [609.6]
Drive Type/No. Speeds	Direct/1	Direct/1	Direct/1	Direct/1
CFM [L/s]	4000 [1888]	4000 [1888]	4000 [1888]	4000 [1888]
No. Motors/HP	1 at 1/3 HP	1 at 1/3 HP	1 at 1/3 HP	1 at 1/3 HP
Motor RPM	1075	1075	1075	1075
<b>Indoor Fan - Type</b>	FC Centrifugal	FC Centrifugal	FC Centrifugal	FC Centrifugal
No. Used/Diameter in. [mm]	1/11x10 [279x254]	1/11x10 [279x254]	1/11x10 [279x254]	1/11x10 [279x254]
Drive Type/No. Speeds	Belt/Variable	Belt/Variable	Belt/Variable	Belt/Variable
No. Motors	1	1	1	1
Motor HP	1 1/2	1 1/2	1 1/2	1 1/2
Motor RPM	1725	1725	1725	1725
Motor Frame Size	0	0	0	0
<b>Filter - Type</b>	Disposable	Disposable	Disposable	Disposable
Furnished	Yes	Yes	Yes	Yes
(NO.) Size Recommended in. [mm x mm x mm]	(4)2x16x16 [51x406x406]	(4)2x16x16 [51x406x406]	(4)2x16x16 [51x406x406]	(4)2x16x16 [51x406x406]
<b>Refrigerant Charge Oz. [g]</b>	191 [5415]	191 [5415]	191 [5415]	191 [5415]
<b>Weights</b>				
Net Weight lbs. [kg]	689 [312.5]	689 [312.5]	689 [312.5]	689 [312.5]
Ship Weight lbs. [kg]	696 [315.7]	696 [315.7]	696 [315.7]	696 [315.7]

### NOTES:

- Cooling Performance is rated at 95° F ambient, 80° F entering dry bulb, 67° F entering wet bulb. Gross capacity does not include the effect of fan motor heat. ARI capacity is net and includes the effect of fan motor heat. Units are suitable for operation to ±20% of nominal cfm. Units are certified in accordance with the Unitary Air Conditioner Equipment certification program, which is based on ARI Standard 210/240 or 360.
- EER and/or SEER are rated at ARI conditions and in accordance with DOE test procedures.
- Heating Performance limit settings and rating data were established and approved under laboratory test conditions using American National Standard Institute standards. Ratings shown are for elevations up to 2000 feet. For elevations above 2000 feet, ratings should be reduced at the rate of 4% for each 1000 feet above sea level.
- Outdoor Sound Rating shown is tested in accordance with ARI Standard 270.

# GENERAL DATA - RKKL MODELS

## NOMINAL SIZES 6 TON [21.1 kW]

Model RKKL - Series	B072DL10E	B072DL13E	B072DM10E	B072DM13E
<b>Cooling Performance<sup>1</sup></b>				<b>Continued -&gt;</b>
Gross Cooling Capacity Btu [kW]	73,000 [21.39]	73,000 [21.39]	73,000 [21.39]	73,000 [21.39]
EER/SEER <sup>2</sup>	11.2/NA	11.2/NA	11.2/NA	11.2/NA
Nominal CFM/ARI Rated CFM [L/s]	2400/2050 [1133/967]	2400/2050 [1133/967]	2400/2050 [1133/967]	2400/2050 [1133/967]
ARI Net Cooling Capacity Btu [kW]	70,000 [20.51]	70,000 [20.51]	70,000 [20.51]	70,000 [20.51]
Net Sensible Capacity Btu [kW]	49,700 [14.56]	49,700 [14.56]	49,700 [14.56]	49,700 [14.56]
Net Latent Capacity Btu [kW]	20,300 [5.95]	20,300 [5.95]	20,300 [5.95]	20,300 [5.95]
Integrated Part Load Value <sup>3</sup>	N/A	N/A	N/A	N/A
Net System Power kW	6.21	6.21	6.21	6.21
<b>Heating Performance (Gas)<sup>4</sup></b>				
Heating Performance (Gas) <sup>4</sup>	100,000 [29.3]	135,000 [39.55]	100,000 [29.3]	135,000 [39.55]
Heating Performance (Gas) <sup>4</sup>	81,000 [23.73]	109,400 [32.05]	81,000 [23.73]	109,400 [32.05]
Temperature Rise Range °F [°C]	20-50 [11.1/27.8]	30-60 [16.7/33.3]	20-50 [11.1/27.8]	30-60 [16.7/33.3]
Steady State Efficiency (%)	81	81	81	81
No. Burners	5	6	5	6
No. Stages	1	1	1	1
Gas Connection Pipe Size in. [mm]	0.5 [12.7]	0.5 [12.7]	0.5 [12.7]	0.5 [12.7]
<b>Compressor</b>				
No./Type	1/Scroll	1/Scroll	1/Scroll	1/Scroll
<b>Outdoor Sound Rating (dB)<sup>5</sup></b>	83	83	83	83
<b>Outdoor Coil - Fin Type</b>	Louvered	Louvered	Louvered	Louvered
Tube Type	Rifled	Rifled	Rifled	Rifled
Tube Size in. [mm] OD	0.375 [9.5]	0.375 [9.5]	0.375 [9.5]	0.375 [9.5]
Face Area sq. ft. [sq. m]	16.56 [1.54]	16.56 [1.54]	16.56 [1.54]	16.56 [1.54]
Rows / FPI [FPcm]	2 / 22 [9]	2 / 22 [9]	2 / 22 [9]	2 / 22 [9]
<b>Indoor Coil - Fin Type</b>	Corrugated	Corrugated	Corrugated	Corrugated
Tube Type	Rifled	Rifled	Rifled	Rifled
Tube Size in. [mm]	0.375 [9.5]	0.375 [9.5]	0.375 [9.5]	0.375 [9.5]
Face Area sq. ft. [sq. m]	6.5 [0.6]	6.5 [0.6]	6.5 [0.6]	6.5 [0.6]
Rows / FPI [FPcm]	4 / 12 [5]	4 / 12 [5]	4 / 12 [5]	4 / 12 [5]
Refrigerant Control	TX Valves	TX Valves	TX Valves	TX Valves
Drain Connection No./Size in. [mm]	1/1 [25.4]	1/1 [25.4]	1/1 [25.4]	1/1 [25.4]
<b>Outdoor Fan - Type</b>	Propeller	Propeller	Propeller	Propeller
No. Used/Diameter in. [mm]	1/24 [609.6]	1/24 [609.6]	1/24 [609.6]	1/24 [609.6]
Drive Type/No. Speeds	Direct/1	Direct/1	Direct/1	Direct/1
CFM [L/s]	4000 [1888]	4000 [1888]	4000 [1888]	4000 [1888]
No. Motors/HP	1 at 1/3 HP	1 at 1/3 HP	1 at 1/3 HP	1 at 1/3 HP
Motor RPM	1075	1075	1075	1075
<b>Indoor Fan - Type</b>	FC Centrifugal	FC Centrifugal	FC Centrifugal	FC Centrifugal
No. Used/Diameter in. [mm]	1/11x10 [279x254]	1/11x10 [279x254]	1/11x10 [279x254]	1/11x10 [279x254]
Drive Type/No. Speeds	Belt/Variable	Belt/Variable	Belt/Variable	Belt/Variable
No. Motors	1	1	1	1
Motor HP	1 1/2	1 1/2	1 1/2	1 1/2
Motor RPM	1725	1725	1725	1725
Motor Frame Size	0	0	0	0
<b>Filter - Type</b>	Disposable	Disposable	Disposable	Disposable
Furnished	Yes	Yes	Yes	Yes
(NO.) Size Recommended in. [mm x mm x mm]	(4)2x16x16 [51x406x406]	(4)2x16x16 [51x406x406]	(4)2x16x16 [51x406x406]	(4)2x16x16 [51x406x406]
<b>Refrigerant Charge Oz. [g]</b>	191 [5415]	191 [5415]	191 [5415]	191 [5415]
<b>Weights</b>				
Net Weight lbs. [kg]	689 [312.5]	689 [312.5]	689 [312.5]	689 [312.5]
Ship Weight lbs. [kg]	696 [315.7]	696 [315.7]	696 [315.7]	696 [315.7]

### NOTES:

- Cooling Performance is rated at 95° F ambient, 80° F entering dry bulb, 67° F entering wet bulb. Gross capacity does not include the effect of fan motor heat. ARI capacity is net and includes the effect of fan motor heat. Units are suitable for operation to ±20% of nominal cfm. Units are certified in accordance with the Unitary Air Conditioner Equipment certification program, which is based on ARI Standard 210/240 or 360.
- EER and/or SEER are rated at ARI conditions and in accordance with DOE test procedures.
- Heating Performance limit settings and rating data were established and approved under laboratory test conditions using American National Standard Institute standards. Ratings shown are for elevations up to 2000 feet. For elevations above 2000 feet, ratings should be reduced at the rate of 4% for each 1000 feet above sea level.
- Outdoor Sound Rating shown is tested in accordance with ARI Standard 270.

# GENERAL DATA - RKKL MODELS

## NOMINAL SIZES 6 TON [21.1 kW]

Model RKKL - Series	B072YL13E	B072YM13E
<b>Cooling Performance<sup>1</sup></b>		
Gross Cooling Capacity Btu [kW]	73,000 [21.39]	73,000 [21.39]
EER/SEER <sup>2</sup>	11.2/NA	11.2/NA
Nominal CFM/ARI Rated CFM [L/s]	2400/2050 [1133/967]	2400/2050 [1133/967]
ARI Net Cooling Capacity Btu [kW]	70,000 [20.51]	70,000 [20.51]
Net Sensible Capacity Btu [kW]	49,700 [14.56]	49,700 [14.56]
Net Latent Capacity Btu [kW]	20,300 [5.95]	20,300 [5.95]
Integrated Part Load Value <sup>3</sup>	N/A	N/A
Net System Power kW	6.21	6.21
<b>Heating Performance (Gas)<sup>4</sup></b>		
Heating Performance (Gas) <sup>4</sup>	135,000 [39.55]	135,000 [39.55]
Heating Performance (Gas) <sup>4</sup>	109,400 [32.05]	109,400 [32.05]
Temperature Rise Range °F [°C]	30-60 [16.7/33.3]	30-60 [16.7/33.3]
Steady State Efficiency (%)	81	81
No. Burners	6	6
No. Stages	1	1
Gas Connection Pipe Size in. [mm]	0.5 [12.7]	0.5 [12.7]
<b>Compressor</b>		
No./Type	1/Scroll	1/Scroll
<b>Outdoor Sound Rating (dB)<sup>5</sup></b>		
	83	83
<b>Outdoor Coil - Fin Type</b>		
Tube Type	Louvered	Louvered
Tube Size in. [mm] OD	Rifled	Rifled
Face Area sq. ft. [sq. m]	0.375 [9.5]	0.375 [9.5]
Rows / FPI [FPcm]	16.56 [1.54]	16.56 [1.54]
	2 / 22 [9]	2 / 22 [9]
<b>Indoor Coil - Fin Type</b>		
Tube Type	Corrugated	Corrugated
Tube Size in. [mm]	Rifled	Rifled
Face Area sq. ft. [sq. m]	0.375 [9.5]	0.375 [9.5]
Rows / FPI [FPcm]	6.5 [0.6]	6.5 [0.6]
Refrigerant Control	4 / 12 [5]	4 / 12 [5]
Drain Connection No./Size in. [mm]	TX Valves	TX Valves
	1/1 [25.4]	1/1 [25.4]
<b>Outdoor Fan - Type</b>		
No. Used/Diameter in. [mm]	Propeller	Propeller
Drive Type/No. Speeds	1/24 [609.6]	1/24 [609.6]
CFM [L/s]	Direct/1	Direct/1
No. Motors/HP	4000 [1888]	4000 [1888]
Motor RPM	1 at 1/3 HP	1 at 1/3 HP
	1075	1075
<b>Indoor Fan - Type</b>		
No. Used/Diameter in. [mm]	FC Centrifugal	FC Centrifugal
Drive Type/No. Speeds	1/11x10 [279x254]	1/11x10 [279x254]
No. Motors	Belt/Variable	Belt/Variable
Motor HP	1	1
Motor RPM	1 1/2	1 1/2
Motor Frame Size	1725	1725
	0	0
<b>Filter - Type</b>		
Furnished	Disposable	Disposable
(NO.) Size Recommended in. [mm x mm x mm]	Yes	Yes
	(4)2x16x16 [51x406x406]	(4)2x16x16 [51x406x406]
<b>Refrigerant Charge Oz. [g]</b>		
	191 [5415]	191 [5415]
<b>Weights</b>		
Net Weight lbs. [kg]	689 [312.5]	689 [312.5]
Ship Weight lbs. [kg]	696 [315.7]	696 [315.7]

### NOTES:

- Cooling Performance is rated at 95° F ambient, 80° F entering dry bulb, 67° F entering wet bulb. Gross capacity does not include the effect of fan motor heat. ARI capacity is net and includes the effect of fan motor heat. Units are suitable for operation to ±20% of nominal cfm. Units are certified in accordance with the Unitary Air Conditioner Equipment certification program, which is based on ARI Standard 210/240 or 360.
- EER and/or SEER are rated at ARI conditions and in accordance with DOE test procedures.
- Heating Performance limit settings and rating data were established and approved under laboratory test conditions using American National Standard Institute standards. Ratings shown are for elevations up to 2000 feet. For elevations above 2000 feet, ratings should be reduced at the rate of 4% for each 1000 feet above sea level.
- Outdoor Sound Rating shown is tested in accordance with ARI Standard 270.

# XIII. MISCELLANEOUS

ELECTRICAL DATA – RKKL SERIES							
		B072CL	B072CM	B072DL	B072DM	B072YL	B072YM
Unit Information	Unit Operating Voltage Range	187-253	187-253	414-506	414-506	518-632	518-632
	Volts	208/230	208/230	460	460	575	575
	Minimum Circuit Ampacity	33/33	33/33	17	17	13	13
	Minimum Overcurrent Protection Device Size	40/40	40/40	20	20	15	15
	Maximum Overcurrent Protection Device Size	50/50	50/50	20	20	15	15
Compressor Motor	No.	1	1	1	1	1	1
	Volts	208/230	208/230	460	460	575	575
	Phase	3	3	3	3	3	3
	RPM	3450	3450	3450	3450	3450	3450
	HP, Compressor 1	5	5	5	5	5	5
	Amps (RLA), Comp. 1	19.1/0	19.1/0	9.8	9.8	7.5	7.5
	Amps (LRA), Comp. 1	123/0	123/0	62	62	50	50
Condenser Motor	No.	1	1	1	1	1	1
	Volts	208/230	208/230	460	460	575	575
	Phase	1	1	1	1	1	1
	HP	1/3	1/3	1/3	1/3	1/3	1/3
	Amps (FLA, each)	2.6/2.6	2.6/2.6	1.25	1.25	0.9	0.9
	Amps (LRA, each)	4.7/4.7	4.7/4.7	2.4	2.4	1.5	1.5
Evaporator Fan	No.	1	1	1	1	1	1
	Volts	208/230	208/230	460	460	575	575
	Phase	3	3	3	3	3	3
	HP	1 1/2	1 1/2	1 1/2	1 1/2	1 1/2	1 1/2
	Amps (FLA, each)	5.8/5.8	5.8/5.8	2.8	2.8	2.1	2.1
	Amps (LRA)	34/34	34/34	17	17	13.1	13.1

# AIRFLOW PERFORMANCE – 6 TON [21.10 kW] THREE PHASE BELT DRIVE

AIR FLOW CFM [L/s]		EXTERNAL STATIC PRESSURE—INCHES OF WATER [KPA]																													
		0.1 [.02]		0.2 [.05]		0.3 [.07]		0.4 [.10]		0.5 [.12]		0.6 [.15]		0.7 [.17]		0.8 [.20]		0.9 [.22]		1.0 [.25]		1.1 [.27]		1.2 [.30]		1.3 [.32]		1.4 [.35]		1.5 [.37]	
		RPM	W	RPM	W	RPM	W	RPM	W	RPM	W	RPM	W	RPM	W	RPM	W	RPM	W	RPM	W	RPM	W	RPM	W	RPM	W	RPM	W	RPM	W
1800 [850]	—	—	—	—	785	560	605	895	650	930	670	720	1010	760	1050	800	1090	850	1120	890	1150	940	1180	980	1210	1015	—	—	—	—	
1900 [897]	—	—	—	785	580	615	875	680	915	700	955	740	990	770	1020	815	1070	855	1135	960	1165	1015	1195	1075	1220	1115	—	—	—	—	
2000 [944]	—	775	600	815	625	860	880	740	920	870	955	820	985	880	1030	960	1100	1025	1130	1060	1190	1180	1220	1250	1240	1295	—	—	—	—	
2100 [991]	—	810	650	840	680	880	740	920	870	945	850	880	1015	930	1050	1000	1120	1100	1145	1180	1220	1205	1260	1230	1330	1255	1380	—	—	—	—
2200 [1038]	780	660	825	700	865	750	910	810	945	850	980	880	1015	930	1050	1000	1120	1100	1145	1180	1220	1205	1260	1230	1330	1255	1380	—	—	—	—
2300 [1085]	815	720	855	760	890	830	930	870	960	910	1000	960	1035	1005	1100	1130	1135	1180	1250	1200	1325	1220	1370	1240	1425	—	—	—	—	—	—
2400 [1133]	845	780	880	835	920	900	950	945	990	1025	1050	1055	1110	1085	1155	1120	1215	1150	1335	1185	1355	1220	1430	1235	1470	1255	1525	—	—	—	—
2500 [1180]	870	855	910	915	945	975	980	1020	1020	1085	1045	1140	1080	1200	1110	1260	1135	1300	1205	1450	1230	1530	1250	1560	1295	1630	—	—	—	—	—
2600 [1227]	900	945	940	1005	975	1060	1005	1105	1040	1175	1065	1225	1100	1295	1135	1350	1165	1425	1200	1505	1240	1635	1270	1665	—	—	—	—	—	—	—
2700 [1274]	930	1075	970	1100	1000	1145	1030	1200	1060	1260	1090	1335	1125	1385	1155	1470	1185	1540	1220	1615	1255	1730	—	—	—	—	—	—	—	—	—
2800 [1321]	960	1150	1000	1195	1025	1240	1055	1305	1085	1350	1115	1440	1145	1510	1180	1560	1210	1620	1235	1740	1295	1825	—	—	—	—	—	—	—	—	—

**NOTE:** L-Drive left of bold line, M-Drive right of bold line.

DRIVE PACKAGE	L						M							
MOTOR H.P. [W]	1-1/2 [1119]						1-1/2 [1119]							
BLOWER SHEAVE	6.4" PITCH DIAMETER						6.4" PITCH DIAMETER							
MOTOR SHEAVE	2.8" - 3.8" PITCH DIAMETER—ADJ.						3.4" - 4.4" PITCH DIAMETER—ADJ.							
TURNS OPEN	0	1	2	3	4	5	6	0	1	2	3	4	5	6
RPM	1100	1050	<b>1000</b>	945	895	845	780	1295	1230	1195	<b>1145</b>	1100	1050	1000

- NOTES: 1. Factory sheave settings are shown in bold print.  
 2. Re-adjustment of sheave required to achieve rated airflow at ARI minimum E.S.P.  
 3. Do not operate above blower RPM shown as motor overloading will occur.

**[ ] Designates Metric Conversions**

**FIGURE 21**  
**WIRING DIAGRAM**

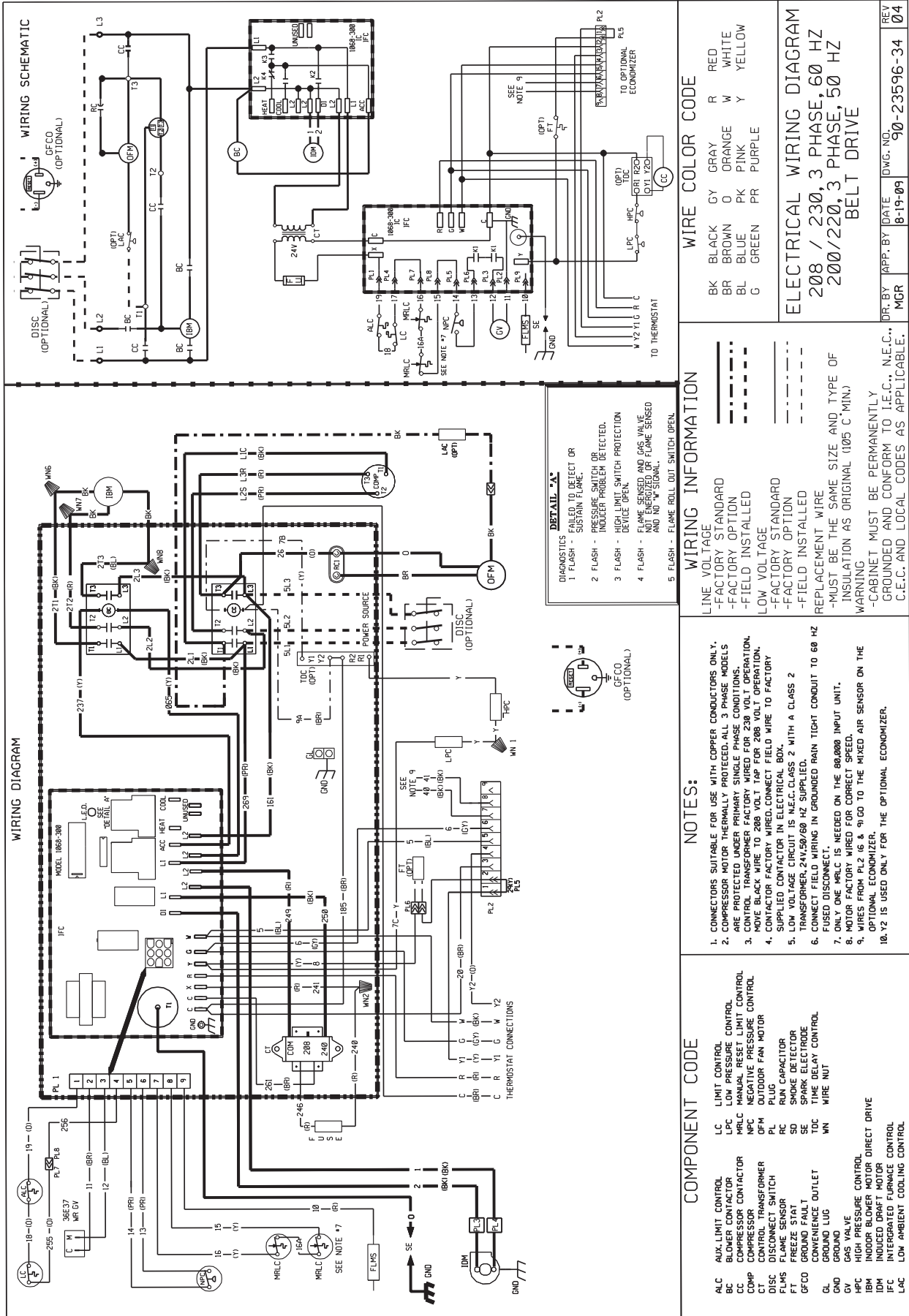

**WIRE COLOR CODE**

BK	BLACK	GY	GRAY	R	RED
BR	BROWN	O	ORANGE	W	WHITE
BL	BLUE	PK	PINK	Y	YELLOW
G	GREEN	PR	PURPLE		

**ELECTRICAL WIRING DIAGRAM**  
208 / 230, 3 PHASE, 60 HZ  
200/220, 3 PHASE, 50 HZ  
BELT DRIVE

DR. BY: APP. BY: DATE: DWG. NO.: REV  
MGR: 8-19-09 90-23596-34 04

**WIRING INFORMATION**

- LINE VOLTAGE
- FACTORY STANDARD
- FACTORY OPTION
- FIELD INSTALLED
- LOW VOLTAGE
- FACTORY STANDARD
- FIELD INSTALLED
- REPLACEMENT WIRE
- MUST BE THE SAME SIZE AND TYPE OF INSULATION AS ORIGINAL (105 C MIN.)
- WARNING
- CABINET MUST BE PERMANENTLY GROUNDED AND CONFORM TO I.E.C., N.E.C., C.E.C. AND LOCAL CODES AS APPLICABLE.

- DETAIL - A**
- DIAGNOSTICS - FAILED TO DETECT OR SUSTAIN FLAME.
  - 1 FLASH - PRESSURE SWITCH OR INDUCER PROBLEM DETECTED.
  - 2 FLASH - HIGH LIMIT SWITCH PROTECTION DEVICE OPEN.
  - 3 FLASH - FLAME SENSED AND GAS VALVE AND NO SIGNAL.
  - 4 FLASH - FLAME SENSED AND NO SIGNAL.
  - 5 FLASH - FLAME ROLL OUT SWITCH OPEN.

**NOTES:**

1. CONNECTORS SUITABLE FOR USE WITH COPPER CONDUCTORS ONLY.
2. COMPRESSOR MOTOR THERMALLY PROTECTED. ALL 3 PHASE MODELS ARE PROTECTED UNDER PRIMARY SINGLE PHASE CONDITIONS.
3. CONTROL TRANSFORMER FACTORY WIRE FOR 230 VOLT OPERATION. MOVE BLACK WIRE TO 208 VOLT TAP FOR 208 VOLT OPERATION.
4. CONTRACTOR FACTORY WIRE. CONNECT FIELD WIRE TO FACTORY SUPPLIED CONTACTOR IN ELECTRICAL BOX.
5. LOW VOLTAGE CIRCUIT IS N.E.C. CLASS 2 WITH A CLASS 2 TRANSFORMER, 24V/250/60 HZ SUPPLIED.
6. CONNECT FIELD WIRING IN GROUNDED RAIN TIGHT CONDUIT TO 60 HZ FUSED DISCONNECT.
7. ONLY ONE MPLC IS NEEDED ON THE 60,000 INPUT UNIT.
8. MOTOR FACTORY WIRE FOR CORRECT SPEED.
9. WIRES FROM PLZ 16 & 9 GO TO THE MIXED AIR SENSOR ON THE OPTIONAL ECONOMIZER.
10. YZ IS USED ONLY FOR THE OPTIONAL ECONOMIZER.

**COMPONENT CODE**

- ALC AUX LIMIT CONTROL
- BLM BLOWER CONTROL
- CC COMPRESSOR CONTACTOR
- COMP COMPRESSOR
- CONTR CONTROL TRANSFORMER
- DISC DISCONNECT SWITCH
- FLMS FLAME SENSING
- FT FREEZE STAT
- GFCO GROUND FAULT CONVENIENCE OUTLET
- GV GAS VALVE
- HPC HIGH PRESSURE CONTROL
- IDM INDOOR BLOWER MOTOR DIRECT DRIVE
- INDUC INDUCED DRAFT MOTOR
- INTGRT INTEGRATED FURNACE CONTROL
- LAC LOW AMBIENT COOLING CONTROL
- LPC LIMIT CONTROL
- LOW PRESSURE CONTROL
- MPLC MANUAL RESET LIMIT CONTROL
- MPC NEGATIVE PRESSURE CONTROL
- PL PLUG
- RC RUN CAPACITOR
- SD SHOCK DETECTOR
- SE SPARK ELECTRODE
- TIME DELAY CONTROL
- WN WIRE NUT

**FIGURE 22**  
**WIRING DIAGRAM**

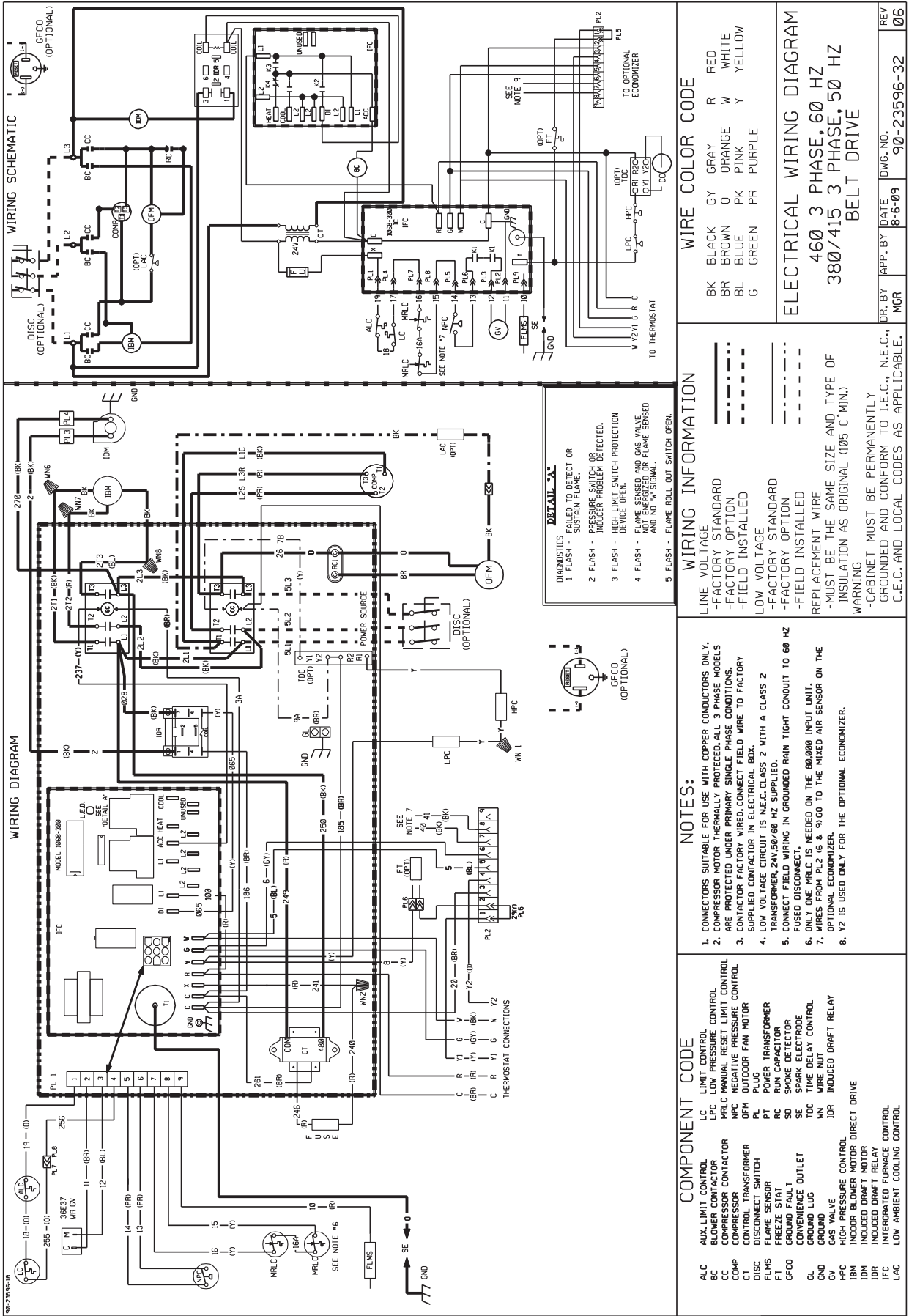

**WIRE COLOR CODE**

BK	BLACK	GY	GRAY	R	RED
BR	BROWN	O	ORANGE	W	WHITE
BL	BLUE	PK	PINK	Y	YELLOW
G	GREEN	PR	PURPLE		

**ELECTRICAL WIRING DIAGRAM**  
460 3 PHASE, 60 HZ  
380/415 3 PHASE, 50 HZ  
BELT DRIVE

**WIRING INFORMATION**

LINE VOLTAGE  
-FACTORY STANDARD  
-FACTORY OPTION  
-FIELD INSTALLED  
LOW VOLTAGE  
-FACTORY STANDARD  
-FACTORY OPTION  
-FIELD INSTALLED

REPLACEMENT WIRE  
-MUST BE THE SAME SIZE AND TYPE OF INSULATION AS ORIGINAL (105 C MIN.)  
WARNING  
-CABINET MUST BE PERMANENTLY GROUNDED AND CONFORM TO I.E.C., N.E.C., C.E.C. AND LOCAL CODES AS APPLICABLE.

**NOTES:**

- CONNECTORS SUITABLE FOR USE WITH COPPER CONDUCTORS ONLY.
- COMPRESSOR MOTOR THERMALLY PROTECTED, ALL 3 PHASE MODELS ARE PROTECTED UNDER PRIMARY SINGLE PHASE CONDITIONS.
- CONTRACTOR FACTORY WIRE, CONNECT FIELD WIRE TO FACTORY SUPPLIED CONTACTOR IN ELECTRICAL BOX.
- LOW VOLTAGE CIRCUIT IS N.E.C. CLASS 2 WITH A CLASS 2 TRANSFORMER, 24V/50/60 HZ SUPPLIED.
- CONNECT FIELD WIRING IN GROUNDED RAIN TIGHT CONDUIT TO 60 HZ FUSED DISCONNECT.
- ONLY ONE MRLC IS NEEDED ON THE 80,000 INPUT UNIT.
- WIRES FROM PL 2 (6 & 9) GO TO THE MIXED AIR SENSOR ON THE OPTIONAL ECONOMIZER.
- Y2 IS USED ONLY FOR THE OPTIONAL ECONOMIZER.

**COMPONENT CODE**

ALC	AUX LIMIT CONTROL	LC	LIMIT CONTROL
BLM	BLOWER CONTACTOR	LPC	LOW PRESSURE LIMIT CONTROL
BC	COMPRESSOR CONTACTOR	MRLC	MANUAL RESET LIMIT CONTROL
CC	COMPRESSOR	NFC	NEGATIVE PRESSURE CONTROL
COMP	CONTROL TRANSFORMER	ODM	OUTDOOR FAN MOTOR
CT	CONTACTOR	PL	PLUG
DISC	DISCONNECT SWITCH	PT	POWER TRANSFORMER
FLMS	FLAME SENSOR	RC	RAIN CHUTE RELAY
FT	FREEZE START	RL	ROOM SELECTOR
GC	GAS CONTROL VALVE	SE	SPARK ELECTRODE
GV	GAS VALVE	TDC	TIME DELAY CONTROL
GRD	GROUND LUG	WV	WIRE NUT
GN	GROUND	IDR	INDUCED DRAFT RELAY
HPC	HIGH PRESSURE CONTROL	IND	INDUCED DRAFT RELAY
IBM	INDOOR BLOWER MOTOR	DIR	DIRECT DRIVE
IBD	INDOOR DRAFT MOTOR	IFC	INDUCED DRAFT MOTOR
IDR	INDUCED DRAFT RELAY	IFC	INDUCED DRAFT MOTOR
LAC	LOW AMBIENT COOLING CONTROL		

DR. BY APP. BY DATE DWG. NO.  
MCR 8-6-09 90-23596-32 REV 06



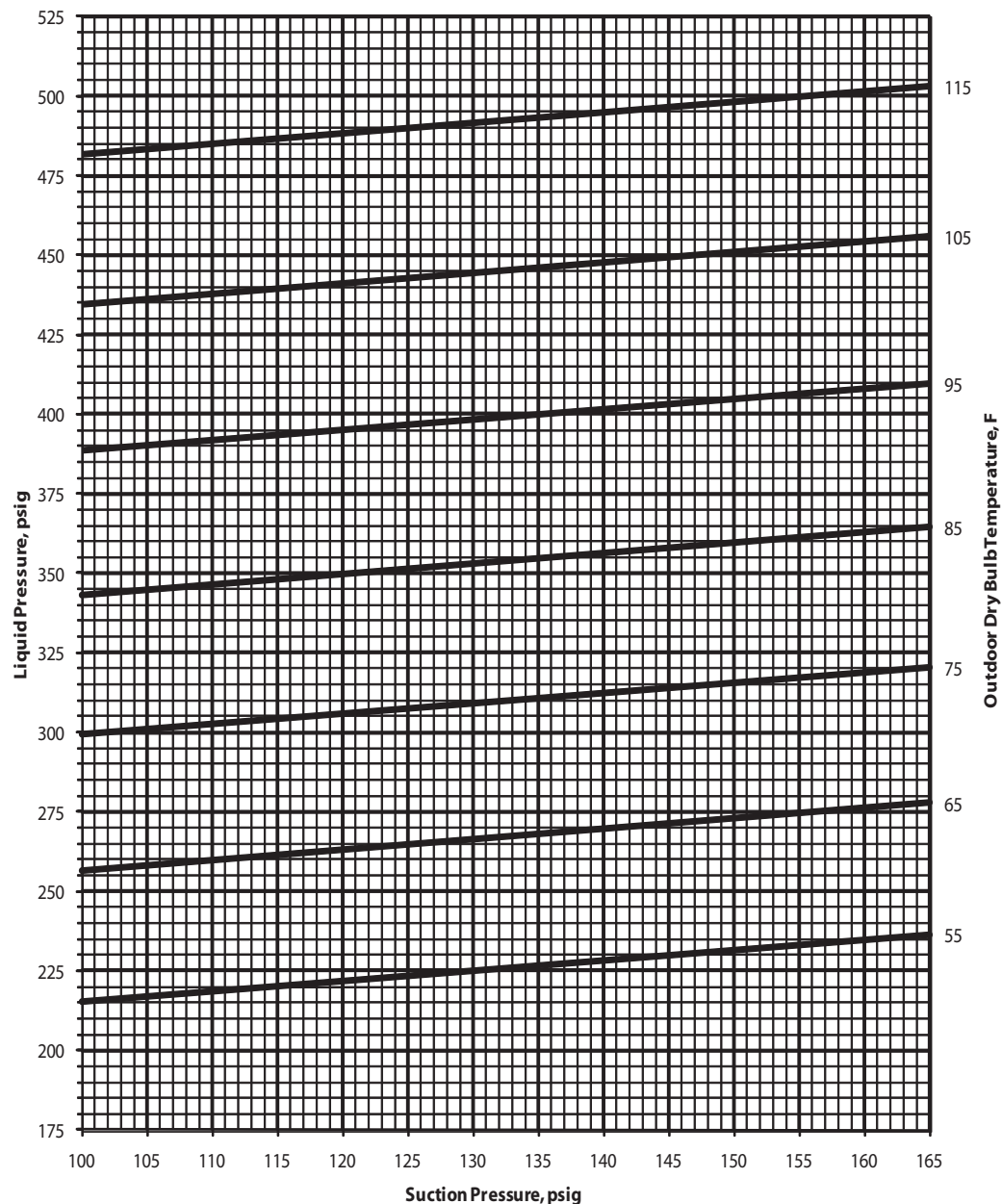

**FIGURE 24**  
SYSTEM CHARGE CHARTS

# 6 TON COOLING

SYSTEM CHARGE CHART - REFRIGERANT 410A  
6 TON, CIRCUIT 1

- CAUTION:** 1. RETURN AIR TEMPERATURE MUST BE WITHIN COMFORT CONDITIONS BEFORE FINAL REFRIGERANT CHECK!
- INSTRUCTIONS:** 1. MEASURE PRESSURE AT COMPRESSOR SUCTION AND LIQUID.  
2. MEASURE OUTDOOR AMBIENT TO UNIT.  
3. PLACE (X) ON CHART WHERE SUCTION AND LIQUID INTERSECT.  
4. IF (X) IS BELOW OUTDOOR AMBIENT LINE, ADD CHARGE AND REPEAT STEPS 1-3.  
5. IF (X) IS ABOVE OUTDOOR AMBIENT LINE, RECOVER EXCESS CHARGE AND REPEAT STEPS 1-3.



92-102259-18-00

# COOLING TROUBLE SHOOTING CHART

**▲ WARNING**

DISCONNECT ALL POWER TO UNIT BEFORE SERVICING. CONTACTOR MAY BREAK ONLY ONE SIDE. FAILURE TO SHUT OFF POWER CAN CAUSE ELECTRICAL SHOCK RESULTING IN PERSONAL INJURY OR DEATH.

SYMPTOM	POSSIBLE CAUSE	REMEDY
Unit will not run	<ul style="list-style-type: none"> <li>• Power off or loose electrical connection</li> <li>• Thermostat out of calibration-set too high</li> <li>• Failed contactor</li> <li>• Blown fuses</li> <li>• Transformer defective</li> <li>• High pressure control open (if provided)</li> <li>• Interconnecting low voltage wiring damaged</li> </ul>	<ul style="list-style-type: none"> <li>• Check for correct voltage at compressor contactor in control box</li> <li>• Reset</li> <li>• Check for 24 volts at contactor coil - replace if contacts are open</li> <li>• Replace fuses</li> <li>• Check wiring-replace transformer</li> <li>• Reset-also see high head pressure remedy-The high pressure control opens at 610 PSIG</li> <li>• Replace thermostat wiring</li> </ul>
Condenser fan runs, compressor doesn't	<ul style="list-style-type: none"> <li>• Run or start capacitor failed (single phase only)</li> <li>• Start relay defective (single phase only)</li> <li>• Loose connection</li> <li>• Compressor stuck, grounded or open motor winding open internal overload.</li> <li>• Low voltage condition</li> <li>• Low voltage condition</li> </ul>	<ul style="list-style-type: none"> <li>• Replace</li> <li>• Replace</li> <li>• Check for correct voltage at compressor - check &amp; tighten all connections</li> <li>• Wait at least 2 hours for overload to reset. If still open, replace the compressor.</li> <li>• At compressor terminals, voltage must be within 10% of rating plate volts when unit is operating.</li> <li>• Add start kit components</li> </ul>
Insufficient cooling	<ul style="list-style-type: none"> <li>• Improperly sized unit</li> <li>• Improper airflow</li> <li>• Incorrect refrigerant charge</li> <li>• Air, non-condensibles or moisture in system</li> <li>• Incorrect voltage</li> </ul>	<ul style="list-style-type: none"> <li>• Recalculate load</li> <li>• Check - should be approximately 400 CFM per ton.</li> <li>• Charge per procedure attached to unit service panel.</li> <li>• Recover refrigerant, evacuate &amp; recharge, add filter drier</li> <li>• At compressor terminals, voltage must be within 10% of rating plate volts when unit is operating.</li> </ul>
Compressor short cycles	<ul style="list-style-type: none"> <li>• Incorrect voltage</li> <li>• Defective overload protector</li> <li>• Refrigerant undercharge</li> </ul>	<ul style="list-style-type: none"> <li>• At compressor terminals, voltage must be <math>\pm 10\%</math> of nameplate marking when unit is operating.</li> <li>• Replace - check for correct voltage</li> <li>• Add refrigerant</li> </ul>
Registers sweat	<ul style="list-style-type: none"> <li>• Low evaporator airflow</li> </ul>	<ul style="list-style-type: none"> <li>• Increase speed of blower or reduce restriction - replace air filter</li> </ul>
High head-low vapor pressures	<ul style="list-style-type: none"> <li>• Restriction in liquid line, expansion device or filter drier</li> <li>• Flow check piston size too small</li> <li>• Incorrect capillary tubes</li> <li>• TXV does not open</li> </ul>	<ul style="list-style-type: none"> <li>• Remove or replace defective component</li> <li>• Change to correct size piston</li> <li>• Change coil assembly</li> <li>• Replace TXV</li> </ul>
High head-high or normal vapor pressure - Cooling mode	<ul style="list-style-type: none"> <li>• Dirty condenser coil</li> <li>• Refrigerant overcharge</li> <li>• Condenser fan not running</li> <li>• Air or non-condensibles in system</li> </ul>	<ul style="list-style-type: none"> <li>• Clean coil</li> <li>• Correct system charge</li> <li>• Repair or replace</li> <li>• Recover refrigerant, evacuate &amp; recharge</li> </ul>
Low head-high vapor pressures	<ul style="list-style-type: none"> <li>• Defective Compressor valves</li> <li>• Incorrect capillary tubes</li> </ul>	<ul style="list-style-type: none"> <li>• Replace compressor</li> <li>• Replace coil assembly</li> </ul>
Low vapor - cool compressor - iced evaporator coil	<ul style="list-style-type: none"> <li>• Low evaporator airflow</li> <li>• Operating below 65°F outdoors</li> <li>• Moisture in system</li> </ul>	<ul style="list-style-type: none"> <li>• Increase speed of blower or reduce restriction - replace air filter</li> <li>• Add Low Ambient Kit</li> <li>• Recover refrigerant - evacuate &amp; recharge - add filter drier</li> </ul>
High vapor pressure	<ul style="list-style-type: none"> <li>• Excessive load</li> <li>• Defective compressor</li> </ul>	<ul style="list-style-type: none"> <li>• Recheck load calculation</li> <li>• Replace</li> </ul>
Fluctuating head & vapor pressures	<ul style="list-style-type: none"> <li>• TXV hunting</li> <li>• Air or non-condensibles in system</li> </ul>	<ul style="list-style-type: none"> <li>• Check TXV bulb clamp - check air distribution on coil - replace TXV</li> <li>• Recover refrigerant, evacuate &amp; recharge</li> </ul>
Gurgle or pulsing noise at expansion device or liquid line	<ul style="list-style-type: none"> <li>• Air or non-condensibles in system</li> </ul>	<ul style="list-style-type: none"> <li>• Recover refrigerant, evacuate &amp; recharge</li> </ul>
Circulating air blower & inducer run continuously, compressor will not start	<ul style="list-style-type: none"> <li>• Manual reset overtemperature control tripped</li> <li>• Wire loose in limit circuit</li> </ul>	<ul style="list-style-type: none"> <li>• Reset or replace</li> <li>• Check wiring</li> </ul>

# FURNACE TROUBLESHOOTING GUIDE

(COMBINATION HEATING AND COOLING UNITS WITH DIRECT SPARK IGNITION)

## ⚠ WARNING



**HAZARDOUS VOLTAGE**  
LINE VOLTAGE CON-  
NECTIONS

**DISCONNECT POWER BEFORE**  
SERVICING.  
SERVICE MUST BE BY A TRAINED,  
QUALIFIED SERVICE TECHNICIAN.

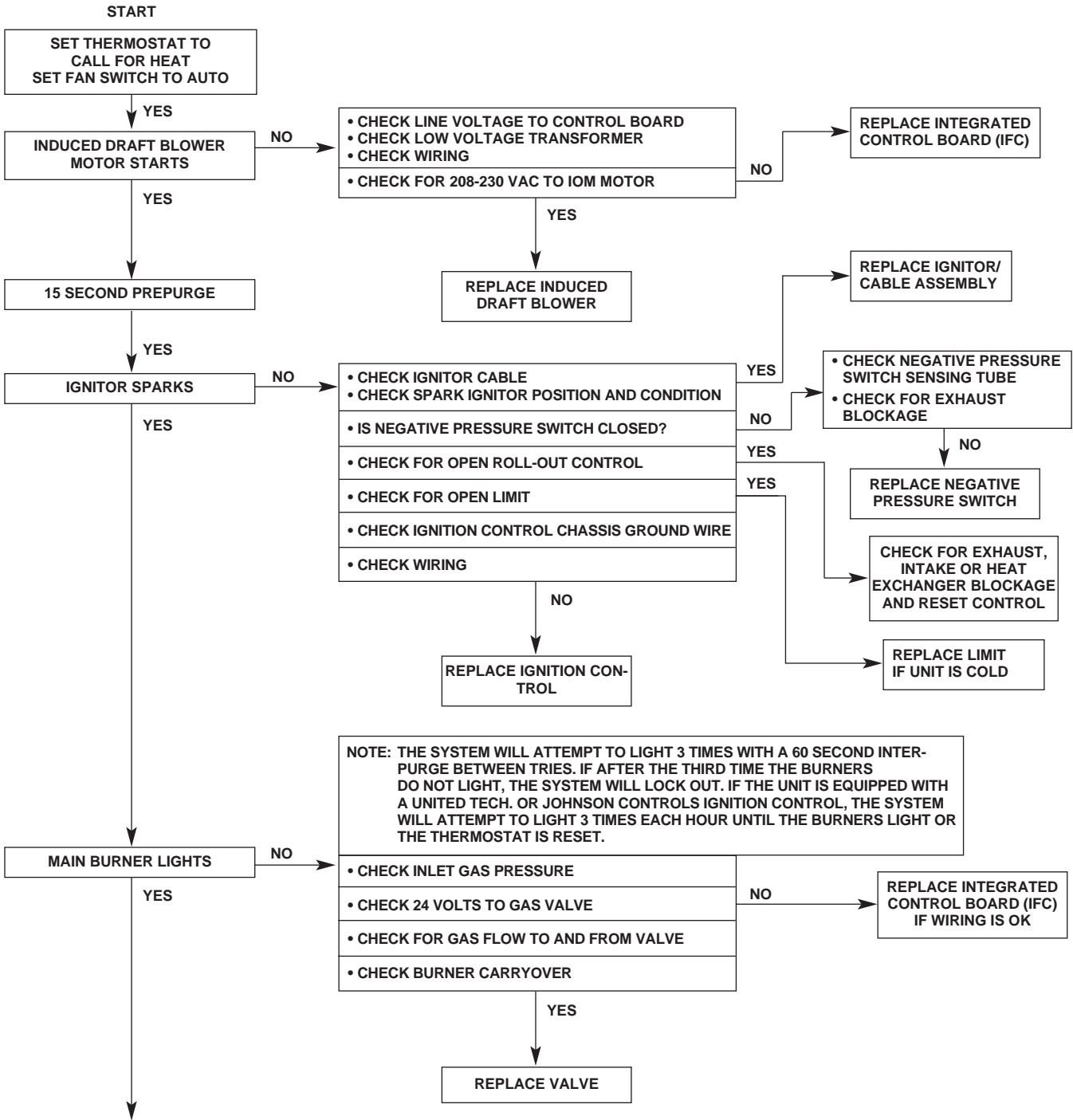

FLOW CHART CONTINUED ON NEXT PAGE

