

AIR CONDITIONER

Floor type



DESIGN & TECHNICAL MANUAL

INDOOR



RIFH09AVFJ
RIFH12AVFJ
RIFH15AVFJ

OUTDOOR



ROSH09AFFJ
ROSH12AFFJ
ROSH15AFFJ

1. INDOOR UNIT

FLOOR TYPE :

RIFH09AVFJ

RIFH12AVFJ

RIFH15AVFJ

CONTENTS

1. INDOOR UNIT

1. FEATURES	01 - 01
2. WIRELESS REMOTE CONTROLLER	01 - 04
3. SPECIFICATIONS	01 - 06
4. DIMENSIONS	01 - 07
5. WIRING DIAGRAMS	01 - 08
6. CAPACITY TABLE	01 - 09
6-1. COOLING CAPACITY.....	01 - 09
6-2. HEATING CAPACITY	01 - 12
7. FAN PERFORMANCE AND CAPACITY	01 - 14
7-1. AIR VELOCITY DISTRIBUTION.....	01 - 14
7-2. AIRFLOW.....	01 - 15
8. OPERATION NOISE (SOUND PRESSURE)	01 - 17
8-1. NOISE LEVEL CURVE	01 - 17
8-2. SOUND LEVEL CHECK POINT	01 - 19
9. ELECTRIC CHARACTERISTICS	01 - 20
10. SAFETY DEVICES	01 - 21
11. EXTERNAL INPUT & OUTPUT	01 - 22
11-1. EXTERNAL INPUT	01 - 22
11-2. EXTERNAL OUTPUT.....	01 - 24
12. FUNCTION SETTINGS	01 - 26
12-1. INDOOR UNIT (Setting by remote controller).....	01 - 26
13. OPTIONAL PARTS	01 - 32
13-1. CONTROLLER.....	01 - 32
13-2. OTHERS.....	01 - 32

1. FEATURES

■ MODEL

RIFH09AVFJ / ROSH09AFFJ
 RIFH12AVFJ / ROSH12AVFJ
 RIFH15AVFJ / ROSH15AVFJ



■ FEATURES

● Energy Efficiency

	MODEL		
	RIFH09AVFJ	RIFH12AVFJ	RIFH15AVFJ
Seasonal Energy Efficiency Ratio (SEER)	26.0	22.7	20.3
Heating Seasonal Performance Factor (HSPF)	12.6	11.6	11.2

MEASUREMENT CONDITIONS
 ANSI/ASHRAE STANDARD 37-1988

● 2-Fan & Wide airflow

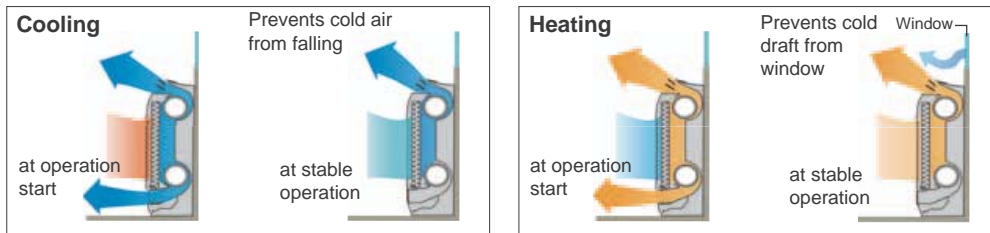

● Low outdoor air temperature correspondence

Corresponds to heating operation at -5 °F(-21°C) outdoor air temperature

Heating
-5 to 75 °F (-21 to 24°C)

● Powerful heating

Heating capacity was improved at low outdoor temperature. This new model can operate even at -5°F (-21°C) low outdoor temperature.

● Powerful operation

Continuous operation by maximum air flow and maximum compressor speed after a certain period of time allows the temperature to reach the setting temp. quickly.

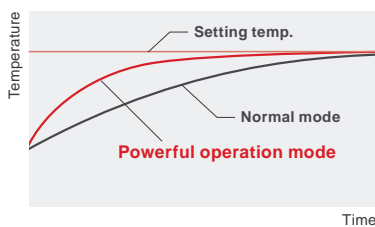

● Flexible & easy installation

Piping space is wide and connection work is easy.



Choice of 6-direction drain & piping connection

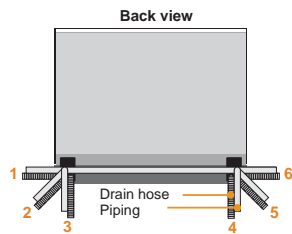

Space is wide and piping work is easy

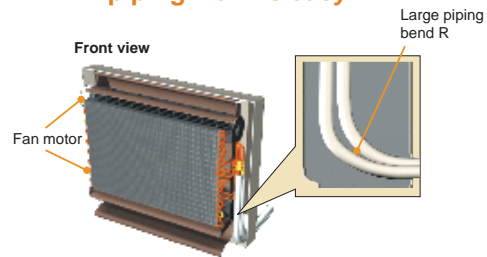

● Super quiet operation

Air flow mode can be set in 4 steps and more detailed air flow setting is possible.

● MIN. HEAT Operation *Only available with Wireless RC.

The room temperature can be set to go no lower than 50°F (10°C), thus ensuring that the room does not get too cold when not occupied

Caution)

- When the room temperature is higher than 50°F (10°C), "MIN. HEAT" operation does not start. Operation starts and maintains the room temperature at 50°F (10°C) when the temperature drops below 50°F (10°C).
- When "MIN. HEAT" operation stops, the room set temperature quickly returns to the preset temperature.

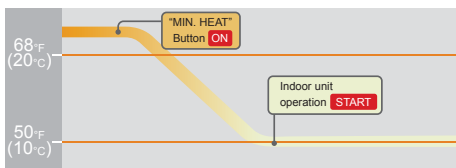

● Economy operation

Limits the maximum operation current, and the power consumption is cut down and the maximum load is suppressed.

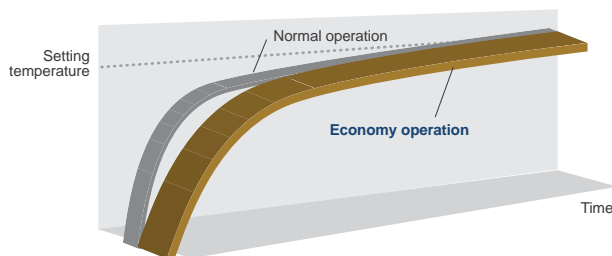

● **Air conditioner filter feature**

Apple-catechin filter



Long-life ion deodorization filter



2. WIRELESS REMOTE CONTROLLER

■ FEATURES



- *4 mode timer setup available (ON / OFF / PROGRAM / SLEEP).
- *Easy operation.
- *Easy to change custom code (max. 4 custom codes) by button operation.

● Built-in timers

Select from four different timer programs (On / Off / Program / Sleep).

● Program timer

The program timer operates the on and off timer once within a 24-hour period.

● Sleep timer

The sleep timer function automatically corrects the temperature thermostat setting according to the timer setting to prevent excessive cooling and heating while sleeping.

Cooling operation/dry operation

When the sleep timer is set, the set temperature automatically rises 2°F (1°C) every hour. The set temperature can rise up to a maximum of 4°F (2°C).

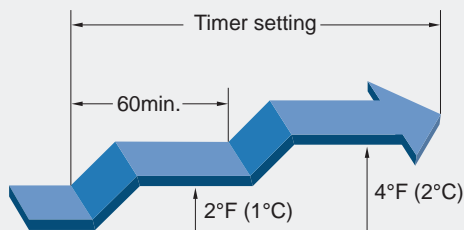

Heating operation

When the sleep timer is set, the set temperature automatically drops 2°F (1°C) every 30 minutes. The set temperature can drop to a maximum of 8°F (4°C).

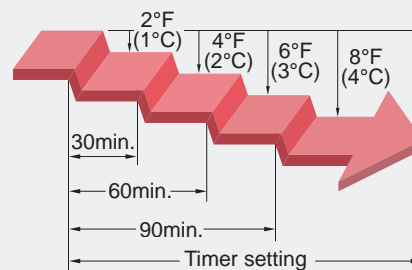

● Simple function setting

Setting of the air conditioner selection function is performed by remote controller.

● Switching remote controller custom code

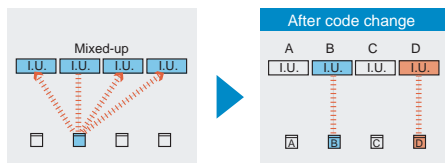

- Code selector switch eliminates unit being wrongly switched.
(Up to 4 custom codes can be set.)

*I.U.=Indoor unit

● To change the temperature unit

Easy to change the temperature unit (°F ↔ °C) by button operation.

FUNCTIONS

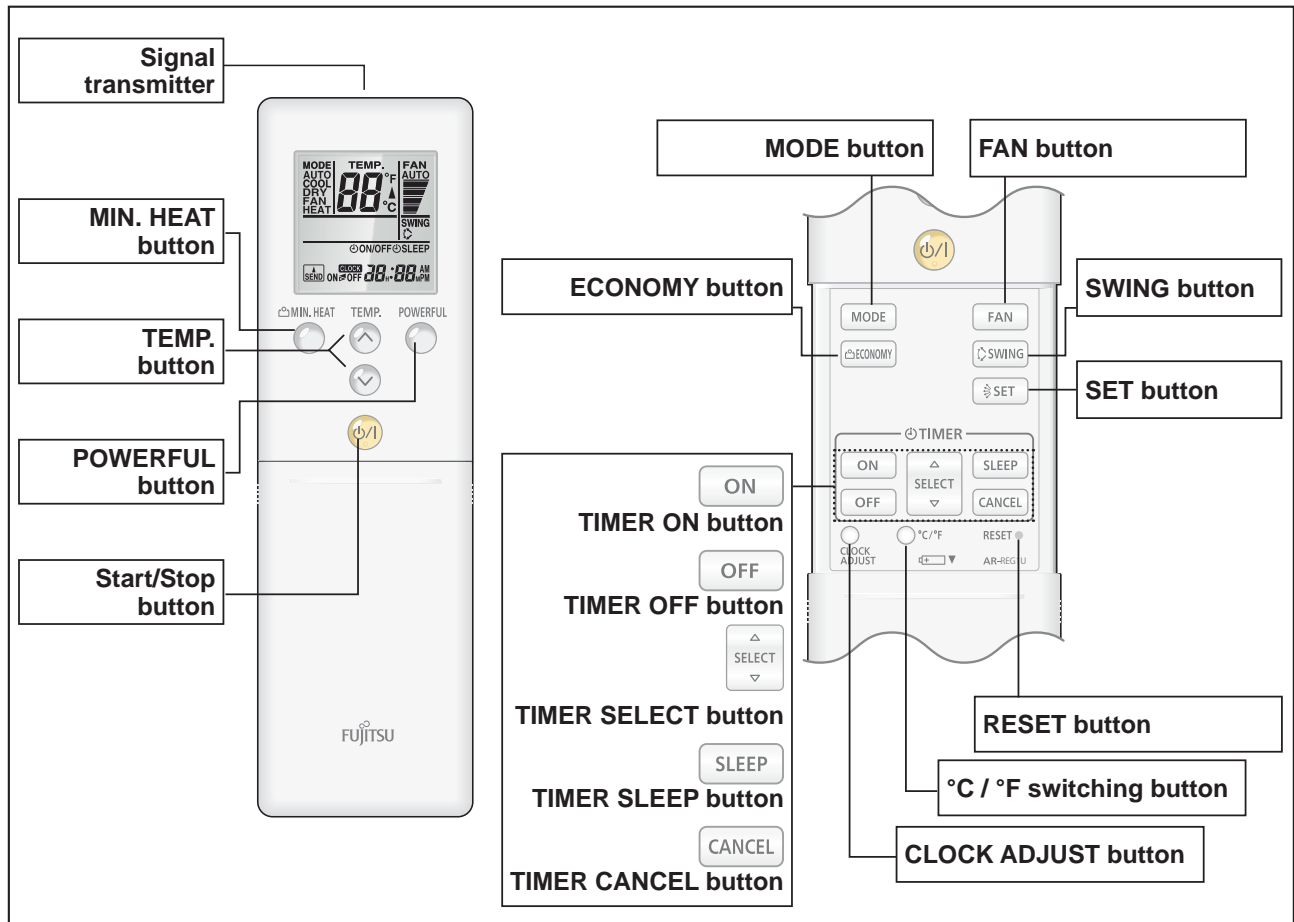

Display panel

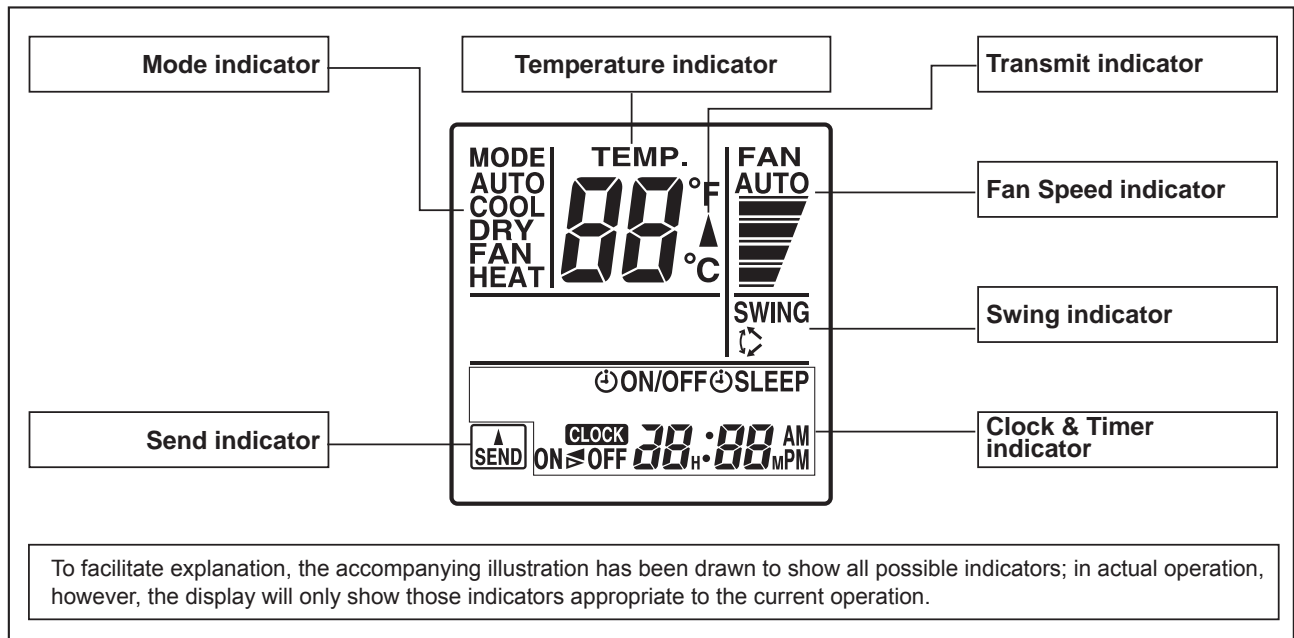

SPECIFICATION

DIMENSIONS [H × W × D]: in. (mm)	8-1/16 (205) × 2-3/8 (61) × 11/16 (17)
WEIGHT oz. (g)	4.3 (122)
ACCESSORY	Holder

NOTE: Some button operations may not be available for all units or systems. For details, refer to the operation manual.

3. SPECIFICATIONS

Type				FLOOR TYPE		
				INVERTER HEAT PUMP		
Model name				RIFH09AVFJ	RIFH12AVFJ	RIFH15AVFJ
Power source				208 / 230 V ~ 60 Hz		
Available voltage range				187 - 253 V		
Capacity	Cooling	Rated	kW	2.64	3.52	4.16
			Btu/h	9000	12000	14,200
		Min. - Max.	kW	0.90 - 3.80	0.90 - 4.20	0.90 - 5.20
	Heating	Rated	Btu/h	3100 - 13,000	3100 - 14,300	3100 - 17,700
			kW	3.52	4.69	5.28
		Min. - Max.	Btu/h	12000	16000	18000
Input power	Cooling	Rated	kW	0.90 - 5.50	0.90 - 5.70	0.90 - 6.10
			Btu/h	3100 - 18,800	3100 - 19,500	3100 - 20,800
		Min. - Max.	kW	0.56	0.91	1.13
	Heating	Rated	kW	0.20 - 2.05	0.20 - 2.05	0.18 - 2.16
			Btu/h	4.71	3.87	3.68
		Min. - Max.	kW	0.88	1.44	1.58
Current	Cooling	Rated	A	2.9	4.2	5.1
	Heating		A	4.1	6.7	7.0
EER	Cooling	kW/kW	4.71	3.87	3.68	
		Btu/hW	16.0	13.1	12.5	
COP	Heating	kW/kW	4.00	3.27	3.34	
		Btu/hW	13.6	11.1	11.3	
SEER	Cooling	Btu/hW	26.0	22.7	20.3	
HSPF	Heating	Btu/hW	12.6	11.6	11.2	
Power factor	Cooling	%	84	94	96	
	Heating	%	93	93	98	
Moisture removal			pints/h (l/h)	2.7 (1.3)	3.8 (1.8)	4.4 (2.1)
Maximum operating current *1			Cooling	9.3	9.3	9.8
			Heating	10.8	10.8	13.8
Fan	Airflow rate	Cooling	High	336 (570)		383 (650)
			Med	271 (460)		306 (520)
			Low	212 (360)		235 (400)
			Quiet	159 (270)		159 (270)
		Heating	High	353 (600)		383 (650)
			Med	283 (480)		306 (520)
			Low	218 (370)		230 (390)
			Quiet	159 (270)		159 (270)
	Type × Q'ty			Cross flow fan × 2		
	Motor output			W	16 × 2	
Sound pressure level *2			Cooling	High	40	44
				Med	35	38
				Low	29	31
				Quiet	23	23
			Heating	High	40	43
				Med	35	37
				Low	29	29
				Quiet	23	23
Heat exchanger type			Dimensions (H × W × D)	in. (mm)		14-7/8 × 21-5/8 × 1-1/16 (378 × 550 × 26.6)
			Fin pitch	FPI	21	
			Rows × Stages	2 × 18		
			Pipe type	Copper		
			Fin type	Aluminum		
Enclosure			Material	Polystyrene		
			Color	White Approximate color of MUNSELL N9.25/		
Dimensions (H × W × D)		Net	inch	23-5/8 × 29-1/8 × 7-7/8		
			mm	600 × 740 × 200		
		Gross	inch	27-9/16 × 32-5/16 × 12-3/16		
			mm	700 × 820 × 310		
Weight		Net	lbs. (kg)	31 (14)		
			Gross	37 (17)		
Connection pipe		Size	Liquid	Ø1/4 (Ø6.35)		
				Gas	Ø3/8 (Ø9.52)	Ø1/2 (Ø12.70)
Method			Flare			
Operation range			Cooling	°F (°C)	64 to 90 (18 to 32)	
				%RH	80 or less	
			Heating	°F (°C)	60 to 88 (16 to 30)	
Remote controller type			Wireless			
Drain hose		Material		PP + LLDPE		
		Size	in.(mm)	Ø9/16(Ø13.8) (I.D.), Ø5/8 to Ø11/16(Ø15.8 to Ø16.7) (O.D.)		

Note :

Specifications are based on the following conditions.

Cooling : Indoor temperature of 80°F (26.67°C) DB / 67°F (19.44°C) WB, and outdoor temperature of 95°F (35°C) DB / 75°F (23.9°C) WB.

Heating : Indoor temperature of 70°F (21.11°C) DB / 59°F (15°C) WB, and outdoor temperature of 47°F (8.33°C) DB / 43°F (6.11°C) WB.

Pipe length : 24ft.(7.5m), Height difference:0 m. (Outdoor unit-Indoor unit)

The protective function might work when using it outside the operation range.

*1: The maximum current is the maximum value when operated within the operation range.

*2: These are the measured values in the manufacturer's anechoic chamber.

Because of the surrounding sound environment, the sound levels measured in actual installation conditions might be higher than the specified values here.

4. DIMENSIONS

■ MODEL: RIFH09AVFJ, RIFH12AVFJ, RIFH15AVFJ

Unit: in. (mm)

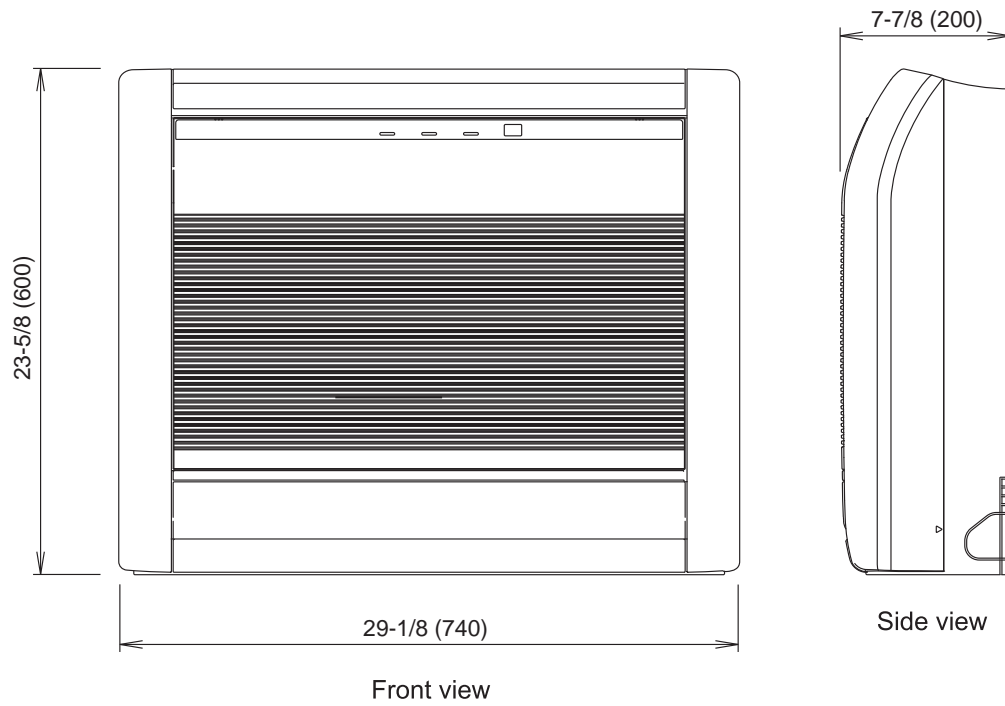

■ INSTALLATION PLACE

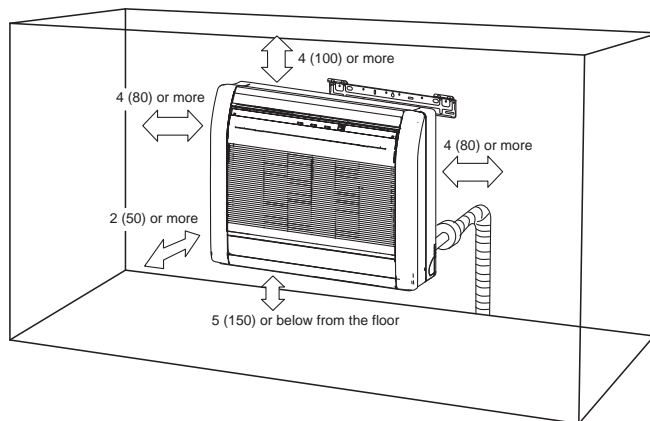

5. WIRING DIAGRAMS

■MODEL: RIFH09AVFJ, RIFH12AVFJ, RIFH15AVFJ

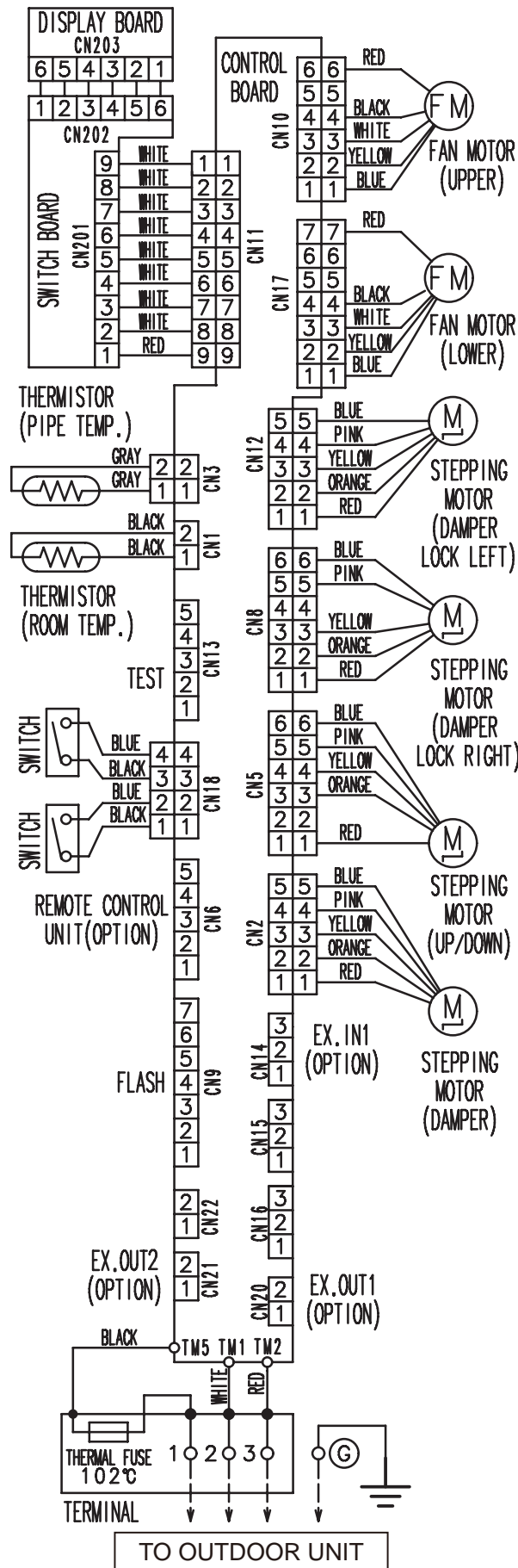

6. CAPACITY TABLE

6-1. COOLING CAPACITY

■MODEL: RIFH09AVFJ

AFR	336
-----	-----

		Indoor temperature																				
		°FDB			64			70			75			80			85			90		
		°FWB			54			60			63			67			71			73		
Outdoor temperature	°FDB	TC	SHC	IP	TC	SHC	IP	TC	SHC	IP	TC	SHC	IP	TC	SHC	IP	TC	SHC	IP			
	15	7.84	6.74	0.20	8.86	6.73	0.21	9.34	7.43	0.21	10.00	7.79	0.21	10.69	7.98	0.21	11.02	8.86	0.21			
	23	7.52	6.44	0.22	8.50	6.44	0.23	8.96	7.10	0.23	9.59	7.45	0.23	10.25	7.62	0.24	10.57	8.47	0.24			
	32	7.11	6.23	0.22	8.04	6.22	0.23	8.47	6.86	0.23	9.07	7.20	0.23	9.70	7.37	0.24	9.99	8.19	0.24			
	41	6.89	6.07	0.23	7.79	6.06	0.24	8.21	6.68	0.24	8.79	7.01	0.24	9.40	7.17	0.25	9.69	7.97	0.25			
	50	6.87	6.04	0.22	7.76	6.03	0.23	8.18	6.65	0.23	8.76	6.98	0.23	9.36	7.14	0.24	9.65	7.94	0.24			
	59	6.11	5.44	0.24	6.90	5.44	0.25	7.27	6.00	0.25	7.79	6.29	0.25	8.33	6.44	0.26	8.58	7.15	0.26			
	67	6.88	6.10	0.26	7.77	6.09	0.27	8.20	6.72	0.27	8.78	7.05	0.27	9.38	7.21	0.28	9.67	8.02	0.28			
	77	7.79	6.88	0.44	8.80	6.87	0.45	9.28	7.58	0.45	9.93	7.95	0.45	10.62	8.14	0.46	10.95	9.04	0.46			
	87	7.36	6.49	0.49	8.32	6.48	0.50	8.77	7.15	0.51	9.39	7.50	0.51	10.04	7.67	0.52	10.35	8.53	0.52			
	95	7.06	6.23	0.54	7.97	6.22	0.55	8.41	6.86	0.55	9.00	7.20	0.56	9.62	7.37	0.57	9.92	8.19	0.57			
	104	6.54	5.77	0.56	7.39	5.76	0.57	7.79	6.35	0.57	8.34	6.67	0.58	8.92	6.82	0.59	9.19	7.58	0.59			
115	6.43	5.69	0.57	7.27	5.68	0.58	7.66	6.26	0.59	8.20	6.57	0.59	8.77	6.73	0.60	9.04	7.48	0.60				

AFR : Air Flow Rate (CFM)
 TC : Total Capacity (kBtu/h)
 SHC : Sensible Heat Capacity (kBtu/h)
 IP : Input Power (kW)

AFR	9.5
-----	-----

		Indoor temperature																				
		°CDB			17.8			21.1			23.9			26.7			29.4			32.2		
		°CWB			12.2			15.6			17.7			19.4			21.7			22.8		
Outdoor temperature	°CDB	TC	SHC	IP	TC	SHC	IP	TC	SHC	IP	TC	SHC	IP	TC	SHC	IP	TC	SHC	IP			
	-10.0	2.30	1.98	0.20	2.60	1.97	0.21	2.74	2.18	0.21	2.93	2.28	0.21	3.13	2.34	0.21	3.23	2.60	0.21			
	-5.0	2.20	1.89	0.22	2.49	1.89	0.23	2.62	2.08	0.23	2.81	2.18	0.23	3.00	2.23	0.24	3.10	2.48	0.24			
	0.0	2.08	1.83	0.22	2.36	1.82	0.23	2.48	2.01	0.23	2.66	2.11	0.23	2.84	2.16	0.24	2.93	2.40	0.24			
	5.0	2.02	1.78	0.23	2.28	1.78	0.24	2.41	1.96	0.24	2.58	2.06	0.24	2.75	2.10	0.25	2.84	2.34	0.25			
	10.0	2.01	1.77	0.22	2.27	1.77	0.23	2.40	1.95	0.23	2.57	2.05	0.23	2.74	2.09	0.24	2.83	2.33	0.24			
	15.0	1.79	1.60	0.24	2.02	1.59	0.25	2.13	1.76	0.25	2.28	1.84	0.25	2.44	1.89	0.26	2.52	2.10	0.26			
	19.4	2.02	1.79	0.26	2.28	1.79	0.27	2.40	1.97	0.27	2.57	2.07	0.27	2.75	2.11	0.28	2.83	2.35	0.28			
	25.0	2.28	2.02	0.44	2.58	2.01	0.45	2.72	2.22	0.45	2.91	2.33	0.45	3.11	2.38	0.46	3.21	2.65	0.46			
	30.6	2.16	1.90	0.49	2.44	1.90	0.50	2.57	2.09	0.51	2.75	2.20	0.51	2.94	2.25	0.52	3.03	2.50	0.52			
	35.0	2.07	1.83	0.54	2.34	1.82	0.55	2.46	2.01	0.55	2.64	2.11	0.56	2.82	2.16	0.57	2.91	2.40	0.57			
	40.0	1.92	1.69	0.56	2.17	1.69	0.57	2.28	1.86	0.57	2.44	1.95	0.58	2.61	2.00	0.59	2.69	2.22	0.59			
46.0	1.89	1.67	0.57	2.13	1.66	0.58	2.25	1.84	0.59	2.40	1.93	0.59	2.57	1.97	0.60	2.65	2.19	0.60				

AFR : Air Flow Rate (m³/min)
 TC : Total Capacity (kW)
 SHC : Sensible Heat Capacity (kW)
 IP : Input Power (kW)

MODEL: RIFH12AVFJ

AFR	336
-----	-----

		Indoor temperature																				
		°FDB			64			70			75			80			85			90		
		°FWB			54			60			63			67			71			73		
Outdoor temperature	°FDB	TC	SHC	IP	TC	SHC	IP	TC	SHC	IP	TC	SHC	IP	TC	SHC	IP	TC	SHC	IP			
	15	10.08	8.23	0.30	11.39	8.22	0.30	12.01	9.06	0.31	12.86	9.51	0.31	13.74	9.73	0.31	14.17	10.81	0.32			
	23	9.57	7.90	0.34	10.81	7.89	0.34	11.40	8.70	0.34	12.21	9.13	0.35	13.05	9.35	0.35	13.45	10.39	0.35			
	32	9.27	7.55	0.36	10.48	7.54	0.37	11.05	8.31	0.37	11.83	8.72	0.38	12.64	8.93	0.38	13.04	9.92	0.38			
	41	9.06	7.46	0.38	10.24	7.45	0.39	10.79	8.22	0.39	11.55	8.62	0.40	12.35	8.82	0.40	12.73	9.80	0.40			
	50	9.03	7.40	0.39	10.21	7.39	0.40	10.76	8.15	0.40	11.52	8.55	0.41	12.31	8.75	0.41	12.70	9.73	0.41			
	59	8.20	6.92	0.37	9.27	6.92	0.38	9.77	7.63	0.38	10.46	8.01	0.39	11.18	8.19	0.39	11.52	9.10	0.39			
	67	9.18	7.71	0.42	10.37	7.70	0.43	10.93	8.50	0.44	11.70	8.91	0.44	12.51	9.12	0.45	12.90	10.14	0.45			
	77	10.40	8.70	0.71	11.76	8.69	0.72	12.39	9.58	0.73	13.27	10.06	0.74	14.18	10.29	0.74	14.62	11.44	0.75			
	87	9.82	8.23	0.80	11.10	8.22	0.82	11.70	9.07	0.82	12.52	9.52	0.83	13.39	9.74	0.84	13.80	10.82	0.85			
	95	9.41	7.87	0.88	10.63	7.86	0.89	11.21	8.67	0.90	12.00	9.10	0.91	12.83	9.31	0.92	13.22	10.35	0.93			
	104	8.74	7.31	0.91	9.87	7.30	0.93	10.41	8.05	0.94	11.14	8.45	0.95	11.91	8.65	0.96	12.28	9.61	0.96			
115	8.57	7.19	0.92	9.69	7.18	0.94	10.22	7.92	0.95	10.94	8.31	0.96	11.69	8.51	0.97	12.05	9.45	0.97				

AFR : Air Flow Rate (CFM)
 TC : Total Capacity (kBtu/h)
 SHC : Sensible Heat Capacity (kBtu/h)
 IP : Input Power (kW)

AFR	9.5
-----	-----

		Indoor temperature																				
		°CDB			17.8			21.1			23.9			26.7			29.4			32.2		
		°CWB			12.2			15.6			17.7			19.4			21.7			22.8		
Outdoor temperature	°CDB	TC	SHC	IP	TC	SHC	IP	TC	SHC	IP	TC	SHC	IP	TC	SHC	IP	TC	SHC	IP			
	-10.0	2.95	2.41	0.30	3.34	2.41	0.30	3.52	2.66	0.31	3.77	2.79	0.31	4.03	2.85	0.31	4.15	3.17	0.32			
	-5.0	2.80	2.32	0.34	3.17	2.31	0.34	3.34	2.55	0.34	3.58	2.68	0.35	3.82	2.74	0.35	3.94	3.04	0.35			
	0.0	2.72	2.21	0.36	3.07	2.21	0.37	3.24	2.44	0.37	3.47	2.56	0.38	3.71	2.62	0.38	3.82	2.91	0.38			
	5.0	2.65	2.19	0.38	3.00	2.18	0.39	3.16	2.41	0.39	3.39	2.53	0.40	3.62	2.59	0.40	3.73	2.87	0.40			
	10.0	2.65	2.17	0.39	2.99	2.17	0.40	3.15	2.39	0.40	3.38	2.51	0.41	3.61	2.56	0.41	3.72	2.85	0.41			
	15.0	2.40	2.03	0.37	2.72	2.03	0.38	2.86	2.24	0.38	3.06	2.35	0.39	3.28	2.40	0.39	3.38	2.67	0.39			
	19.4	2.69	2.26	0.42	3.04	2.26	0.43	3.20	2.49	0.44	3.43	2.61	0.44	3.67	2.67	0.45	3.78	2.97	0.45			
	25.0	3.05	2.55	0.71	3.45	2.55	0.72	3.63	2.81	0.73	3.89	2.95	0.74	4.16	3.02	0.74	4.29	3.35	0.75			
	30.6	2.88	2.41	0.80	3.25	2.41	0.82	3.43	2.66	0.82	3.67	2.79	0.83	3.92	2.85	0.84	4.05	3.17	0.85			
	35.0	2.76	2.31	0.88	3.12	2.30	0.89	3.28	2.54	0.90	3.52	2.67	0.91	3.76	2.73	0.92	3.88	3.03	0.93			
	40.0	2.56	2.14	0.91	2.89	2.14	0.93	3.05	2.36	0.94	3.27	2.48	0.95	3.49	2.53	0.96	3.60	2.82	0.96			
46.0	2.51	2.11	0.92	2.84	2.10	0.94	2.99	2.32	0.95	3.21	2.44	0.96	3.43	2.49	0.97	3.53	2.77	0.97				

AFR : Air Flow Rate (m³/min)
 TC : Total Capacity (kW)
 SHC : Sensible Heat Capacity (kW)
 IP : Input Power (kW)

MODEL: RIFH15AVFJ

AFR	383
-----	-----

		Indoor temperature																				
		°FDB			64			70			75			80			85			90		
		°FWB			54			60			63			67			71			73		
Outdoor temperature	°FDB	TC	SHC	IP	TC	SHC	IP	TC	SHC	IP	TC	SHC	IP	TC	SHC	IP	TC	SHC	IP			
	15	12.17	9.38	0.40	13.75	9.37	0.41	14.49	10.33	0.41	15.52	10.84	0.42	16.59	11.09	0.42	17.10	12.33	0.42			
	23	11.85	9.06	0.43	13.39	9.05	0.44	14.12	9.98	0.44	15.11	10.47	0.45	16.16	10.71	0.45	16.65	11.91	0.45			
	32	11.53	8.77	0.44	13.03	8.75	0.45	13.74	9.66	0.45	14.71	10.13	0.46	15.72	10.37	0.46	16.21	11.52	0.46			
	41	11.40	8.71	0.45	12.88	8.70	0.46	13.58	9.59	0.46	14.54	10.07	0.47	15.54	10.30	0.47	16.02	11.45	0.47			
	50	11.37	8.68	0.47	12.85	8.67	0.48	13.55	9.56	0.48	14.50	10.03	0.49	15.51	10.26	0.49	15.98	11.41	0.49			
	59	10.71	8.62	0.48	12.10	8.61	0.49	12.76	9.50	0.49	13.66	9.97	0.50	14.60	10.20	0.50	15.05	11.33	0.50			
	67	11.59	9.12	0.61	13.10	9.11	0.62	13.81	10.05	0.62	14.79	10.54	0.63	15.81	10.78	0.64	16.29	11.99	0.64			
	77	12.30	9.64	0.90	13.90	9.63	0.91	14.65	10.62	0.92	15.69	11.14	0.93	16.77	11.40	0.94	17.29	12.67	0.95			
	87	11.63	9.11	1.00	13.14	9.10	1.02	13.85	10.04	1.03	14.83	10.53	1.04	15.85	10.78	1.05	16.34	11.98	1.06			
	95	11.13	8.74	1.09	12.58	8.73	1.11	13.26	9.62	1.12	14.20	10.10	1.13	15.18	10.33	1.14	15.65	11.48	1.15			
	104	9.89	7.75	1.14	11.17	7.74	1.16	11.78	8.53	1.17	12.61	8.96	1.18	13.48	9.16	1.19	13.90	10.18	1.20			
115	9.33	7.31	1.15	10.54	7.30	1.17	11.12	8.05	1.18	11.90	8.45	1.19	12.72	8.65	1.20	13.11	9.61	1.21				

AFR : Air Flow Rate (CFM)
 TC : Total Capacity (kBtu/h)
 SHC : Sensible Heat Capacity (kBtu/h)
 IP : Input Power (kW)

AFR	10.8
-----	------

		Indoor temperature																				
		°CDB			17.8			21.1			23.9			26.7			29.4			32.2		
		°CWB			12.2			15.6			17.7			19.4			21.7			22.8		
Outdoor temperature	°CDB	TC	SHC	IP	TC	SHC	IP	TC	SHC	IP	TC	SHC	IP	TC	SHC	IP	TC	SHC	IP			
	-10.0	3.57	2.75	0.40	4.03	2.74	0.41	4.25	3.03	0.41	4.55	3.18	0.42	4.86	3.25	0.42	5.01	3.61	0.42			
	-5.0	3.47	2.65	0.43	3.92	2.65	0.44	4.14	2.92	0.44	4.43	3.07	0.45	4.73	3.14	0.45	4.88	3.49	0.45			
	0.0	3.38	2.57	0.44	3.82	2.57	0.45	4.03	2.83	0.45	4.31	2.97	0.46	4.61	3.04	0.46	4.75	3.38	0.46			
	5.0	3.34	2.55	0.45	3.78	2.55	0.46	3.98	2.81	0.46	4.26	2.95	0.47	4.55	3.02	0.47	4.70	3.35	0.47			
	10.0	3.33	2.54	0.47	3.77	2.54	0.48	3.97	2.80	0.48	4.25	2.94	0.49	4.54	3.01	0.49	4.68	3.34	0.49			
	15.0	3.14	2.53	0.48	3.55	2.52	0.49	3.74	2.78	0.49	4.00	2.92	0.50	4.28	2.99	0.50	4.41	3.32	0.50			
	19.4	3.40	2.67	0.61	3.84	2.67	0.62	4.05	2.94	0.62	4.33	3.09	0.63	4.63	3.16	0.64	4.78	3.51	0.64			
	25.0	3.60	2.83	0.90	4.07	2.82	0.91	4.29	3.11	0.92	4.60	3.27	0.93	4.92	3.34	0.94	5.07	3.71	0.95			
	30.6	3.41	2.67	1.00	3.85	2.67	1.02	4.06	2.94	1.03	4.35	3.09	1.04	4.65	3.16	1.05	4.79	3.51	1.06			
	35.0	3.26	2.56	1.09	3.69	2.56	1.11	3.89	2.82	1.12	4.16	2.96	1.13	4.45	3.03	1.14	4.59	3.37	1.15			
	40.0	2.90	2.27	1.14	3.27	2.27	1.16	3.45	2.50	1.17	3.70	2.62	1.18	3.95	2.69	1.19	4.07	2.98	1.20			
46.0	2.73	2.14	1.15	3.09	2.14	1.17	3.26	2.36	1.18	3.49	2.48	1.19	3.73	2.53	1.20	3.84	2.82	1.21				

AFR : Air Flow Rate (m³/min)
 TC : Total Capacity (kW)
 SHC : Sensible Heat Capacity (kW)
 IP : Input Power (kW)

6-2. HEATING CAPACITY

This table is created using the maximum capacity.

MODEL: RIFH09AVFJ

AFR	353
-----	-----

		Indoor temperature									
		°FDB		60		65		70		75	
		°FDB	°FWB	TC	IP	TC	IP	TC	IP	TC	IP
Outdoor temperature	-5	-7	12.55	1.94	12.15	2.00	11.74	2.06	11.33	2.13	
	5	3	14.38	2.04	13.92	2.11	13.45	2.17	12.98	2.24	
	14	12	14.96	2.07	14.48	2.14	14.00	2.20	13.51	2.27	
	23	19	15.46	2.00	14.97	2.06	14.47	2.12	13.96	2.19	
	32	28	15.89	1.77	15.39	1.82	14.87	1.88	14.35	1.94	
	41	37	18.47	1.72	17.88	1.76	17.28	1.82	16.68	1.87	
	47	43	20.09	1.74	19.46	1.78	18.80	1.84	18.14	1.89	
	50	47	22.20	1.74	21.50	1.79	20.77	1.85	20.05	1.90	
	59	50	23.02	1.75	22.30	1.80	21.54	1.86	20.79	1.91	

AFR : Air Flow Rate (CFM)
TC : Total Capacity (kBtu/h)
IP : Input Power (kW)

AFR	10.0
-----	------

		Indoor temperature									
		°CDB		15.6		18.3		21.1		23.9	
		°CDB	°CWB	TC	IP	TC	IP	TC	IP	TC	IP
Outdoor temperature	-20.6	-21.7	3.68	1.94	3.56	2.00	3.44	2.06	3.32	2.13	
	-15.0	-16.1	4.21	2.04	4.08	2.11	3.94	2.17	3.80	2.24	
	-10.0	-11.1	4.38	2.07	4.25	2.14	4.10	2.20	3.96	2.27	
	-5.0	-7.2	4.53	2.00	4.39	2.06	4.24	2.12	4.09	2.19	
	0.0	-2.2	4.66	1.77	4.51	1.82	4.36	1.88	4.21	1.94	
	5.0	2.8	5.41	1.72	5.24	1.76	5.06	1.82	4.89	1.87	
	8.3	6.1	5.88	1.74	5.69	1.78	5.50	1.84	5.31	1.89	
	10.0	8.3	6.51	1.74	6.30	1.79	6.09	1.85	5.88	1.90	
	15.0	10.0	6.75	1.75	6.53	1.80	6.31	1.86	6.09	1.91	

AFR : Air Flow Rate (m³/min)
TC : Total Capacity (kW)
IP : Input Power (kW)

MODEL: RIFH12AVFJ

AFR	353
-----	-----

		Indoor temperature									
		°FDB		60		65		70		75	
		°FDB	°FWB	TC	IP	TC	IP	TC	IP	TC	IP
Outdoor temperature	-5	-7	14.25	1.94	13.80	2.00	13.33	2.06	12.87	2.13	
	5	3	16.08	2.04	15.58	2.11	15.05	2.17	14.52	2.24	
	14	12	16.31	2.07	15.79	2.14	15.26	2.20	14.72	2.27	
	23	19	16.53	2.00	16.01	2.06	15.46	2.12	14.92	2.19	
	32	28	16.73	1.77	16.20	1.82	15.66	1.88	15.11	1.94	
	41	37	19.23	1.72	18.62	1.76	17.99	1.82	17.36	1.87	
	47	43	20.84	1.74	20.18	1.78	19.50	1.84	18.82	1.89	
	50	47	23.02	1.74	22.30	1.79	21.54	1.85	20.79	1.90	
	59	50	23.86	1.75	23.10	1.80	22.32	1.86	21.54	1.91	

AFR : Air Flow Rate (CFM)
TC : Total Capacity (kBtu/h)
IP : Input Power (kW)

AFR	10.0
-----	------

		Indoor temperature									
		°CDB		15.6		18.3		21.1		23.9	
		°CDB	°CWB	TC	IP	TC	IP	TC	IP	TC	IP
Outdoor temperature	-20.6	-21.7	4.18	1.94	4.04	2.00	3.91	2.06	3.77	2.13	
	-15.0	-16.1	4.71	2.04	4.57	2.11	4.41	2.17	4.26	2.24	
	-10.0	-11.1	4.78	2.07	4.63	2.14	4.47	2.20	4.32	2.27	
	-5.0	-7.2	4.84	2.00	4.69	2.06	4.53	2.12	4.37	2.19	
	0.0	-2.2	4.90	1.77	4.75	1.82	4.59	1.88	4.43	1.94	
	5.0	2.8	5.64	1.72	5.46	1.76	5.27	1.82	5.09	1.87	
	8.3	6.1	6.09	1.74	5.90	1.78	5.70	1.84	5.50	1.89	
	10.0	8.3	6.75	1.74	6.54	1.79	6.31	1.85	6.09	1.90	
	15.0	10.0	6.99	1.75	6.77	1.80	6.54	1.86	6.31	1.91	

AFR : Air Flow Rate (m³/min)
TC : Total Capacity (kW)
IP : Input Power (kW)

MODEL: RIFH15AVFJ

AFR	383
-----	-----

		Indoor temperature									
		°FDB		60		65		70		75	
		°FDB	°FWB	TC	IP	TC	IP	TC	IP	TC	IP
Outdoor temperature	-5	-7	17.12	2.77	16.58	2.85	16.02	2.94	15.46	3.03	
	5	3	18.95	2.87	18.35	2.95	17.73	3.04	17.11	3.13	
	14	12	20.07	2.79	19.44	2.87	18.78	2.96	18.12	3.05	
	23	19	20.92	2.59	20.26	2.67	19.57	2.75	18.89	2.83	
	32	28	21.34	2.20	20.67	2.26	19.97	2.33	19.27	2.40	
	41	37	21.93	1.96	21.24	2.01	20.52	2.07	19.81	2.13	
	47	43	22.23	1.90	21.53	1.95	20.80	2.01	20.07	2.07	
	50	47	24.55	1.97	23.78	2.02	22.97	2.08	22.17	2.14	
	59	50	25.46	1.98	24.65	2.03	23.82	2.09	22.99	2.15	

AFR : Air Flow Rate (CFM)
 TC : Total Capacity (kBtu/h)
 IP : Input Power (kW)

AFR	10.8
-----	------

		Indoor temperature									
		°CDB		15.6		18.3		21.1		23.9	
		°CDB	°CWB	TC	IP	TC	IP	TC	IP	TC	IP
Outdoor temperature	-20.6	-21.7	5.02	2.77	4.86	2.85	4.69	2.94	4.53	3.03	
	-15.0	-16.1	5.55	2.87	5.38	2.95	5.20	3.04	5.01	3.13	
	-10.0	-11.1	5.88	2.79	5.70	2.87	5.50	2.96	5.31	3.05	
	-5.0	-7.2	6.13	2.59	5.94	2.67	5.74	2.75	5.54	2.83	
	0.0	-2.2	6.26	2.20	6.06	2.26	5.85	2.33	5.65	2.40	
	5.0	2.8	6.43	1.96	6.23	2.01	6.02	2.07	5.80	2.13	
	8.3	6.1	6.52	1.90	6.31	1.95	6.10	2.01	5.88	2.07	
	10.0	8.3	7.20	1.97	6.97	2.02	6.73	2.08	6.50	2.14	
	15.0	10.0	7.46	1.98	7.23	2.03	6.98	2.09	6.74	2.15	

AFR : Air Flow Rate (m³/min)
 TC : Total Capacity (kW)
 IP : Input Power (kW)

7. FAN PERFORMANCE AND CAPACITY 7-1.

AIR VELOCITY DISTRIBUTION

■ MODEL: RIFH09AVFJ, RIFH12AVFJ, RIFH15AVFJ

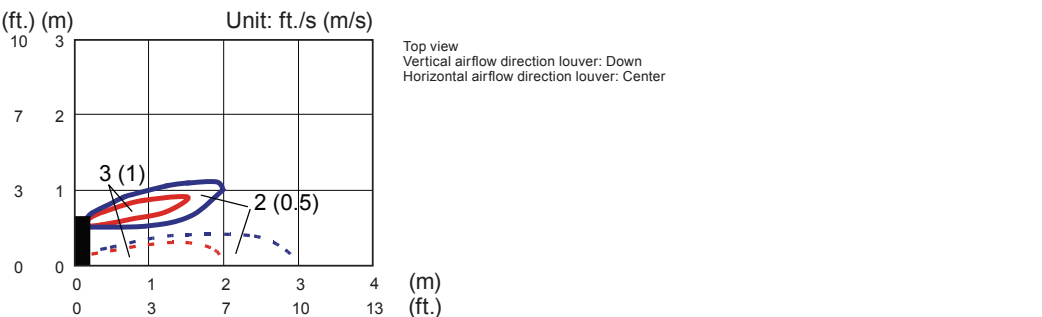
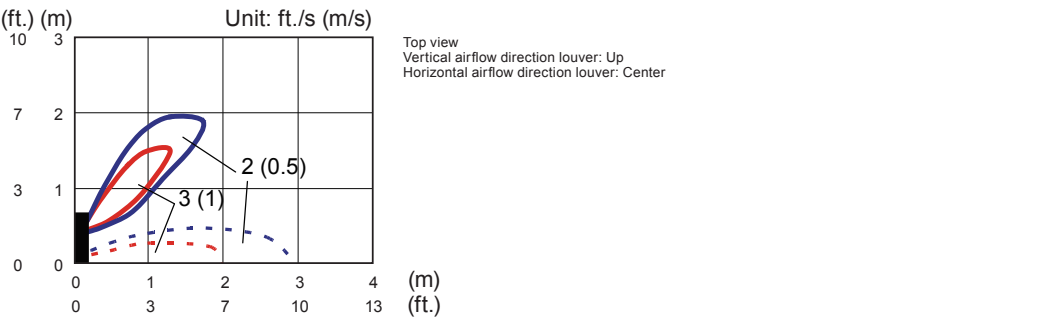
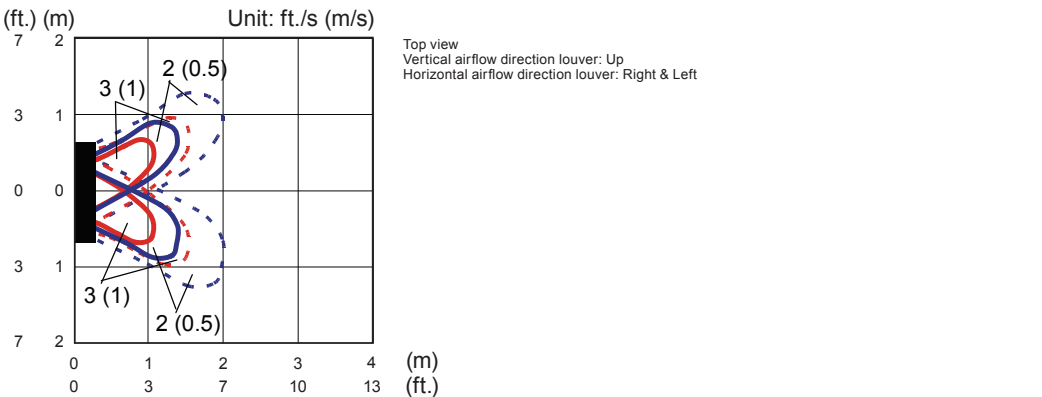
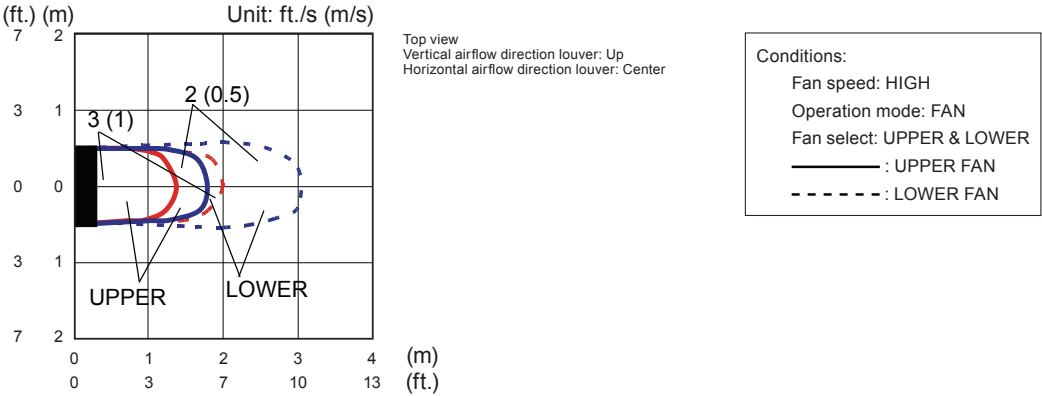

7-2. AIRFLOW

■MODEL: RIFH09AVFJ,RIFH12AVFJ

●Cooling

Fan speed	Number of rotations [r.p.m] (UPPER/LOWER)	Airflow	
HIGH	1190/1000	m ³ /h	570
		l/s	158
		CFM	336
MED	1000/850	m ³ /h	460
		l/s	128
		CFM	271
LOW	820/690	m ³ /h	360
		l/s	100
		CFM	212
QUIET	660/560	m ³ /h	270
		l/s	75
		CFM	159

●Heating

Fan speed	Number of rotations [r.p.m] (UPPER/LOWER)	Airflow	
HIGH	1240/1040	m ³ /h	600
		l/s	167
		CFM	353
MED	1040/880	m ³ /h	480
		l/s	133
		CFM	283
LOW	840/700	m ³ /h	370
		l/s	103
		CFM	218
QUIET	660/560	m ³ /h	270
		l/s	75
		CFM	159

■ MODEL: RIFH15AVFJ

● Cooling

Fan speed	Number of rotations [r.p.m] (UPPER/LOWER)	Airflow	
HIGH	1330/1120	m ³ /h	650
		l/s	181
		CFM	383
MED	1100/930	m ³ /h	520
		l/s	144
		CFM	306
LOW	890/750	m ³ /h	400
		l/s	111
		CFM	235
QUIET	660/560	m ³ /h	270
		l/s	75
		CFM	159

● Heating

Fan speed	Number of rotations [r.p.m] (UPPER/LOWER)	Airflow	
HIGH	1330/1120	m ³ /h	650
		l/s	181
		CFM	383
MED	1100/930	m ³ /h	520
		l/s	144
		CFM	306
LOW	860/730	m ³ /h	390
		l/s	108
		CFM	230
QUIET	660/560	m ³ /h	270
		l/s	75
		CFM	159

8. OPERATION NOISE (SOUND PRESSURE)

8-1. NOISE LEVEL CURVE

■ MODEL: RIFH09AVFJF

● Cooling

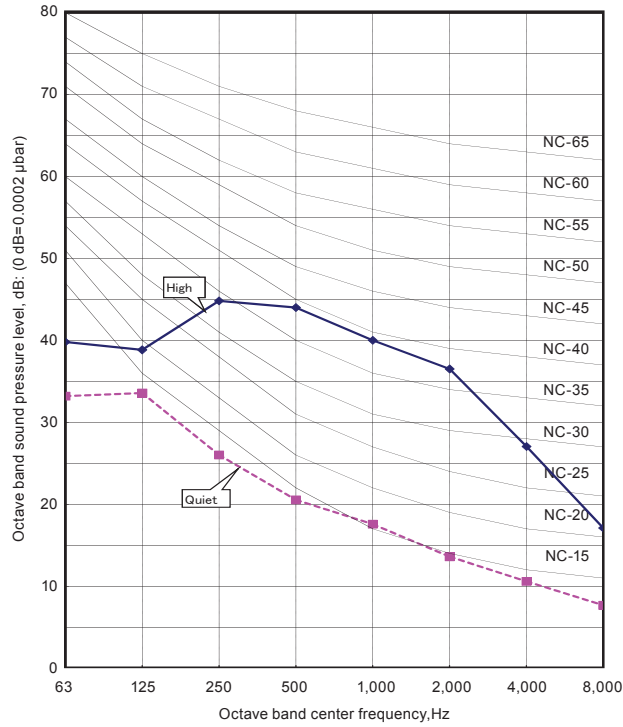

● Heating

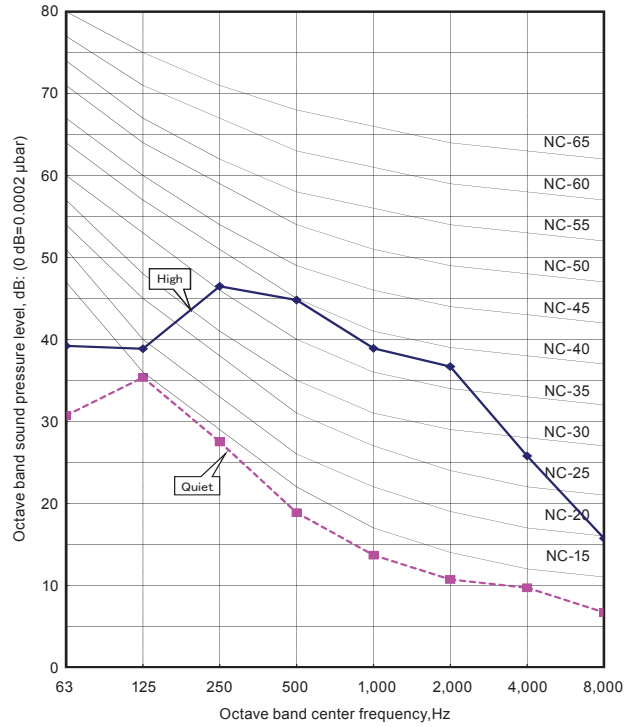

■ MODEL: RIFH12AVFJ

● Cooling

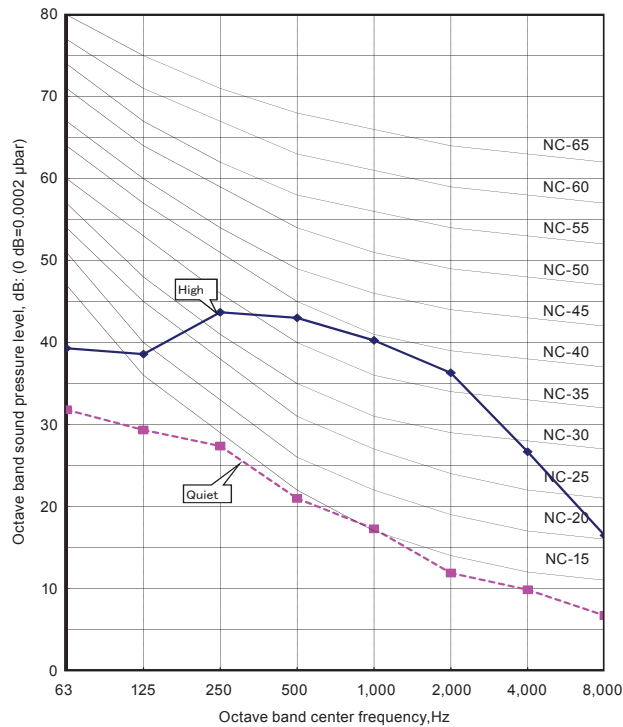

● Heating

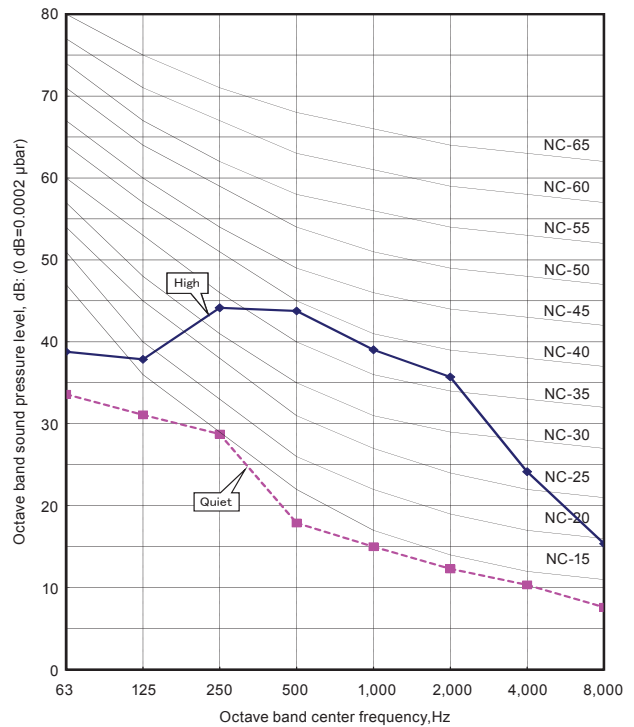

MODEL: RIFH15AVFJ

● Cooling

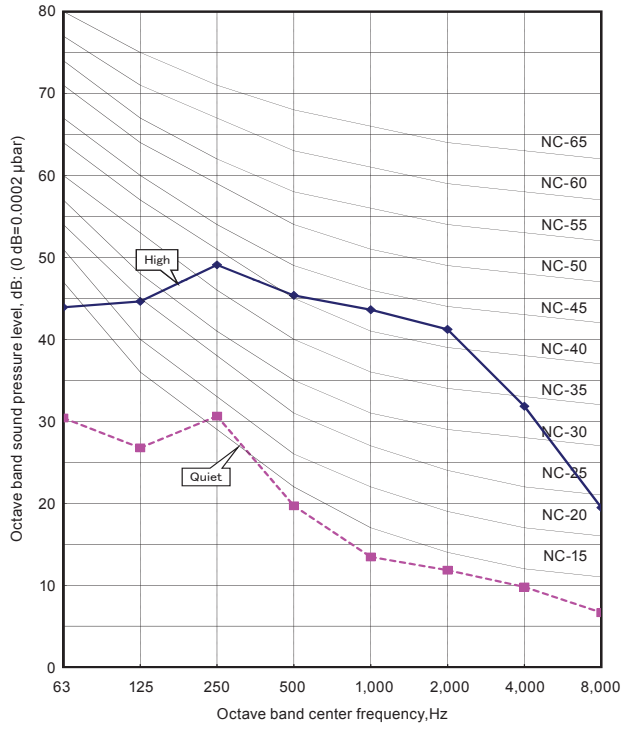

● Heating

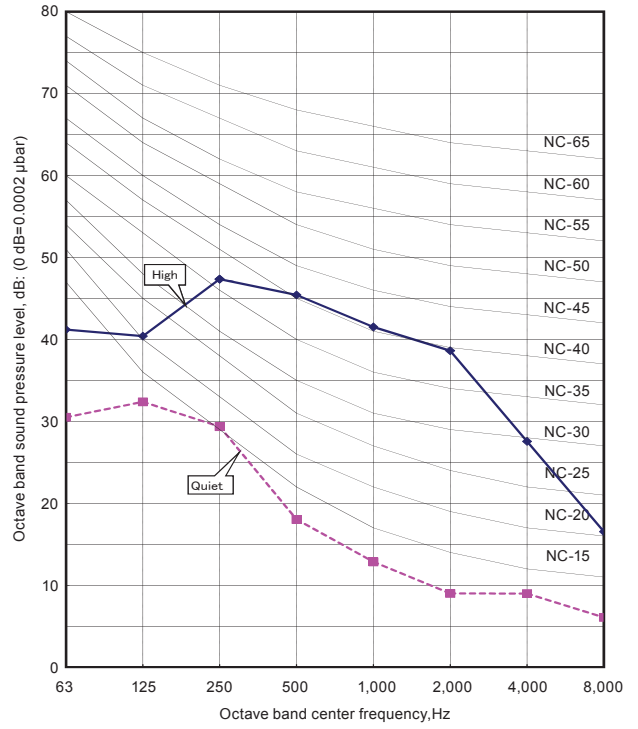

8-2. SOUND LEVEL CHECK POINT

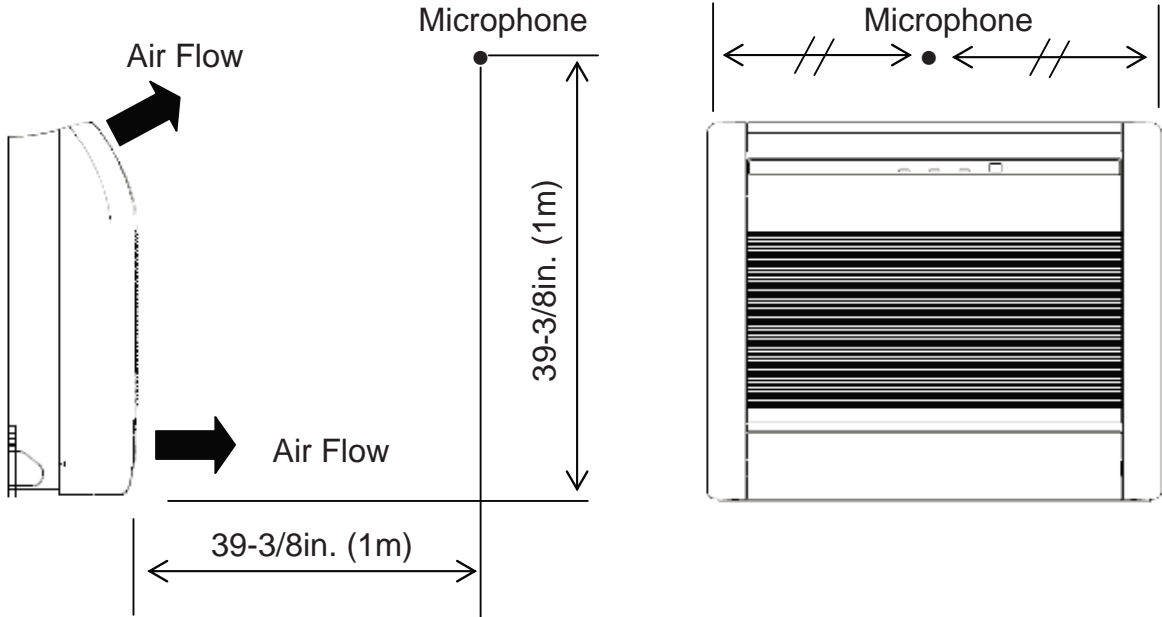

9. ELECTRIC CHARACTERISTICS

Model Name			RIFH09AVFJ	RIFH12AVFJ	RIFH15AVFJ
Power Supply	Voltage	V	208 / 230 ~		
	Frequency	Hz	60		
Max Operating Current		A	0.7		
*)Wiring Spec	Connection Cable	AWG	14		
	Limited wiring length	ft. (m)	69 (21)		

*) Wiring Spec
 Selected Sample
 (Selected based on Japan Electrotechnical Standard and Codes Committee E0005)

10. SAFETY DEVICES

	Protection form	Model		
		RIFH09AVFJ	RIFH12AVFJ	RIFH15AVFJ
Circuit protection	Current fuse (PCB)	250V 3.15A		
Terminal protection	Current (thermal) fuse	250V 3A		
Fan motor protection	Terminal protection program	OFF: 302 ± 27 °F (150 ± 15 °C) ON: 248 ± 27 °F (120 ± 15 °C)		

11. EXTERNAL INPUT & OUTPUT

Connector	INPUT	OUTPUT	REMARKS
CN14	Control input	-	See external input/output settings for details.
CN20	-	Operation status output	
CN21	-	Error status output	

11-1. EXTERNAL INPUT

■ CONTROL INPUT (Operation/Stop or Forced stop)

The air conditioner can be remotely operated by means of the following on-site work.

"Operation/Stop" mode or "Forced stop" mode can be selected with function setting of indoor unit.

Unit operation is started at the following contents by adding the contact input of a commercial ON/OFF switch to a connector on the external control PC board and turning it ON.

Unit operation	Initial setting after power is ON	Starting mode other than initial setting
Operation mode	Auto changeover	Mode at previous operation
Set temperature	76°F (24°C)	Temperature at previous operation
Airflow mode	AUTO	Mode at previous operation
Air direction (swing)	Standard air direction (swing OFF)	Air direction at previous operation

● Circuit diagram example

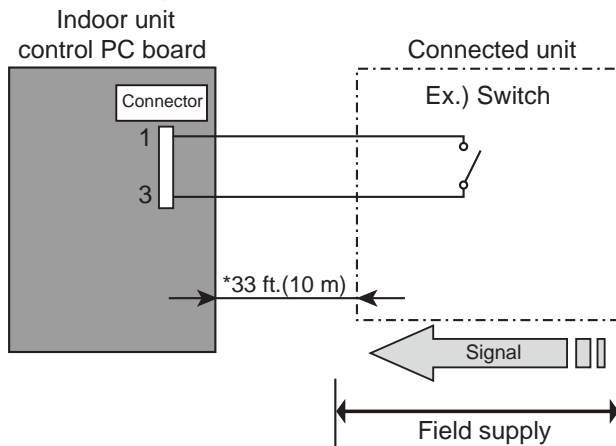

*: Make the distance from the PC board to the connected unit within 33 ft.(10 m).
Contact capacity: DC 24 V or more, 10 mA or more.

● When function setting is in "Operation/Stop" mode

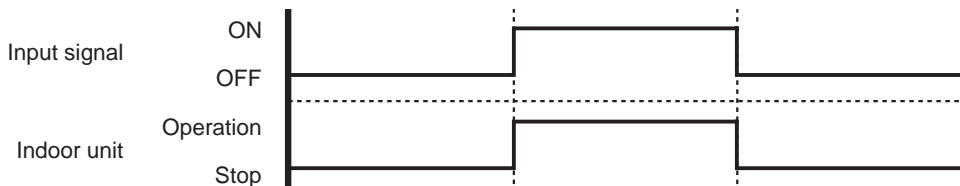

● When function setting is "Forced stop" mode

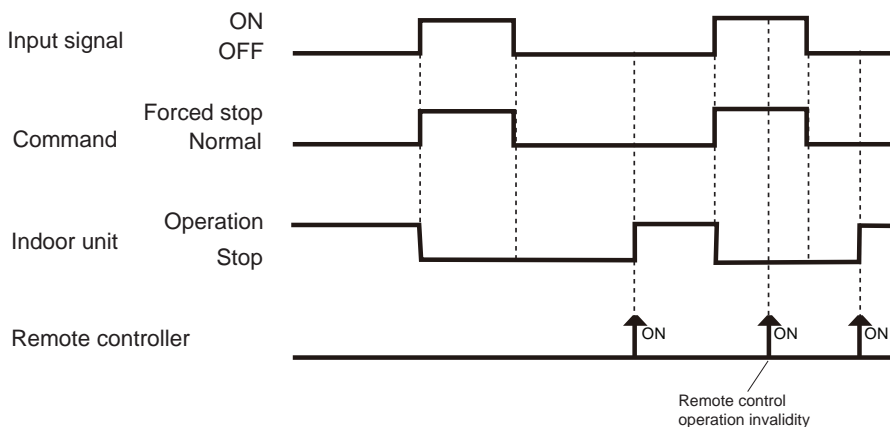

● **Parts (Optional)**

Parts name	Model name
External connect kit	RXXWZXZ5

Wire (External input) : RXXWZXZ5



11-2. EXTERNAL OUTPUT

■ OPERATION STATUS OUTPUT

An air conditioner operation status signal can be output.

● Circuit diagram example

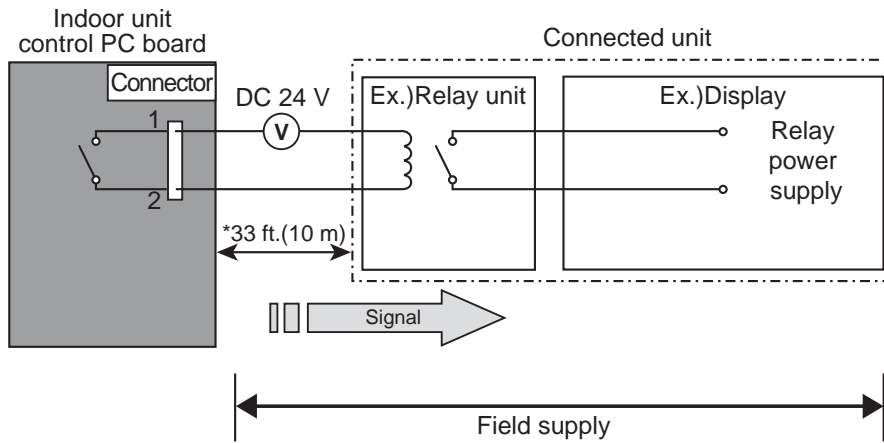

*: Make the distance from the PC board to the connected unit within 33 ft.(10 m).
Relay spec.: Max. DC 24 V, 10 mA to less than 500 mA.

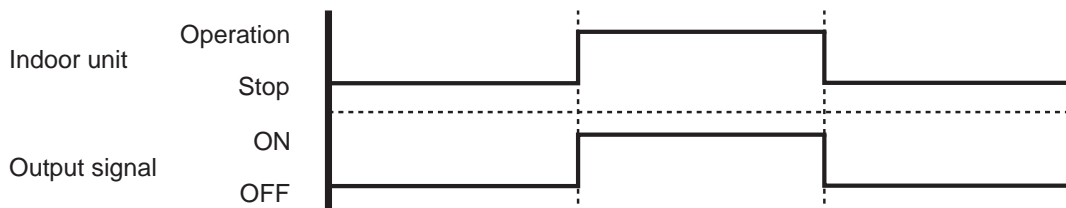

● Parts (Optional)

Parts name	Model name
External connect kit	RXXWZXZ5

Wire (External output) : RXXWZXZ5



■ ERROR STATUS OUTPUT

An air conditioner error status signal can be output.

● Circuit diagram example

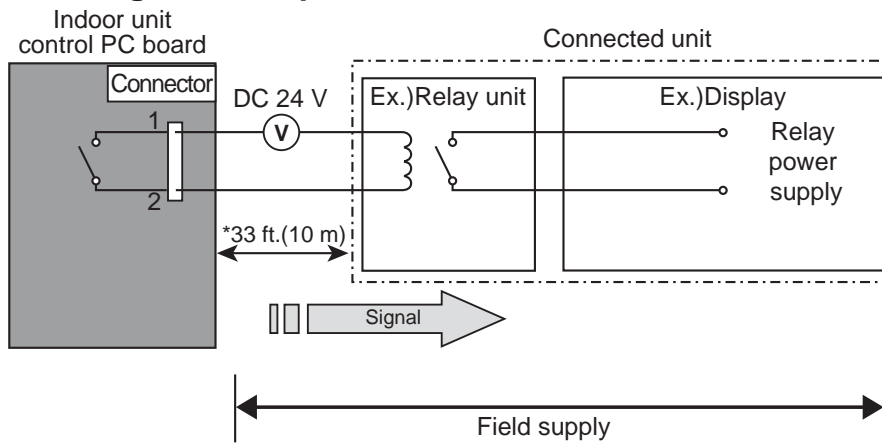

*: Make the distance from the PC board to the connected unit within 33 ft.(10 m).
Relay spec.: Max. DC 24 V, 10 mA to less than 500 mA.

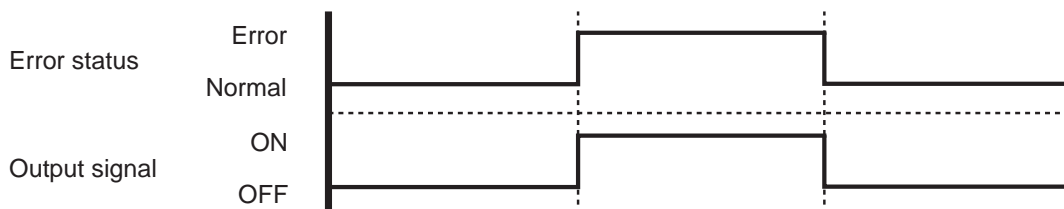

● Parts (Optional)

Parts name	Model name
External connect kit	RXXWZXZ5

Wire (External output) : RXXWZXZ5



12. FUNCTION SETTINGS

12-1. INDOOR UNIT (Setting by remote controller)

- The function settings of the control of the indoor unit can be changed by this procedure according to the installation conditions. Incorrect settings can cause the indoor unit to malfunction.
- After the power is turned on, perform the Function Setting according to the installation conditions using the remote controller.
- The settings may be selected between the following two: Function Number and Setting Value.
- Settings will not be changed if invalid numbers or setting values are selected.

■ PREPARATION

- Before turning on the power of the indoor unit:
 - Confirm whether the piping air-tight test and vacuuming have been conducted.
 - Reconfirm whether there is no miswiring.
- Turn on the power of the indoor units.

■ FUNCTION SETTING METHOD (for Wireless remote controller)

Entering the Function Setting Mode

- While pressing the POWERFUL button and SET TEMP. (Λ) simultaneously, press the RESET button to enter the function setting mode.

STEP 1

Setting the Remote controller Custom Code

Use the following steps to select the custom code of the remote controller. (Note that the air conditioner cannot receive a signal if the air conditioner has not been set for the matching custom code.) The custom codes that are set through this process are applicable only during the Function Setting process. For details on how to set the custom codes through the normal process, refer to "REMOTE CONTROLLER CUSTOM CODE SETTING".

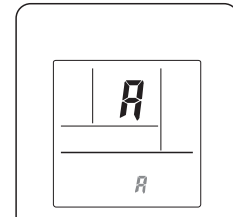

1. Press the SET TEMP. (Λ) (V) button to change the custom code between $\bar{A} \rightarrow \bar{b} \rightarrow \bar{c} \rightarrow \bar{d}$.
Match the code on the display to the air conditioner custom code. (initially set to \bar{A})
(If the custom code does not need to be selected, press the MIN. HEAT button and proceed to **STEP 2**.)
2. Press the MODE button and check that the indoor unit can receive signals at the displayed custom code.
3. Press the MIN. HEAT button to accept the custom code, and proceed to **STEP 2**.

The air conditioner custom code is set to "A" prior to shipment.

The remote controller resets to custom code A when the batteries in the remote controller are replaced. If you use a custom code other than custom code A, reset the custom code after replacing the batteries.
If you do not know the air conditioner custom code setting, try each of the custom codes ($\bar{A} \rightarrow \bar{b} \rightarrow \bar{c} \rightarrow \bar{d}$) until you find the code which operates the air conditioner.

STEP 2

Selecting the Function Number and Setting Value

1. Press the SET TEMP. (Λ) (V) buttons to select the function number.
(Press the MIN. HEAT button to switch between the left and right digits.)
2. Press the POWERFUL button to proceed to setting the value.
(Press the POWERFUL button again to return to the function number selection.)
3. Press the SET TEMP. (Λ) (V) buttons to select the setting value.
(Press the MIN. HEAT button to switch between the left and right digits.)
4. Press the MODE button, then the START/STOP button in order to fix the settings.
5. Press the RESET button to end the function setting mode.
6. After completing the Function Setting, be sure to turn off the power and turn it on again.

Function number

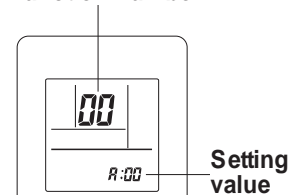

⚠ CAUTION

After turning off the power, wait 30 seconds or more before turning on it again.
The Function Setting will not become active unless the power is turned off then on again.

■ FUNCTION DETAILS

Functions	
1)	Filter sign
2)	Vertical airflow direction range control
3)	Room temperature control for indoor unit sensor
4)	Auto restart
5)	Room temperature sensor switching
6)	Remote controller custom code
7)	External input control
8)	Room temperature sensor switching (Aux.)
9)	Indoor unit fan control for energy saving for cooling
10)	Room temperature control for wired remote controller sensor
11)	Heat Insulation condition (building insulation)

1) Filter sign

Select appropriate intervals for displaying the filter sign on the indoor unit according to the estimated amount of dust in the air of the room.

If the indication is not required, select "No indication" (03).

◆... Factory setting)

Function number	Setting value	Setting description
11	00	Standard (400 hours)
	01	Long interval (1000 hours)
	02	Short interval (200 hours)
	03	No indication ◆

2) Vertical airflow direction range control

In a concealed installation, change the setting to "Fixed" (02) to restrict the movement of the upper air outlet so that the airflow is only towards the horizontal direction.

(◆... Factory setting)

Function number	Setting value	Setting description
23	00	Standard ◆
	01	(Setting prohibited)
	02	Fixed (Concealed)

3) Room temperature control for indoor unit sensor

Refer to Function 95, before performing this setting.

Depending on the installed environment, correction of the room temperature sensor may be required.

Select the appropriate control setting according to the installed environment.

The temperature correction values show the difference from the Standard setting "00" (manufacturer's recommended value).

*When Function 95-01(High insulation) is set, the Standard setting "00" will be the same as No correction "01" [0.0°F (0.0°C)].

(◆... Factory setting)

Function number	Setting value	Setting description	
30 (For cooling)	31 (For heating)	00	Standard setting*
		01	No correction 0.0°F 0.0°C
		02	-1°F (-0.5°C)
		03	-2°F (-1.0°C)
		04	-3°F (-1.5°C)
		05	-4°F (-2.0°C)
		06	-5°F (-2.5°C)
		07	-6°F (-3.0°C)
		08	-7°F (-3.5°C)
		09	-8°F (-4.0°C)
		10	+1°F (+0.5°C)
		11	+2°F (+1.0°C)
		12	+3°F (+1.5°C)
		13	+4°F (+2.0°C)
		14	+5°F (+2.5°C)
		15	+6°F (+3.0°C)
		16	+7°F (+3.5°C)
17	+8°F (+4.0°C)		

4) Auto restart

Enable or disable automatic restart after a power interruption.

(◆... Factory setting)

Function number	Setting value	Setting description
40	00	Enable
	01	Disable

*Auto restart is an emergency function such as for power outage etc.
Do not attempt to use this function in normal operation.
Be sure to operate the unit by remote controller or external device.

5) Room temperature sensor switching

(Only for wired remote controller)

When using the Wired remote controller temperature sensor, change the setting to "Both" (01).

(◆... Factory setting)

Function number	Setting value	Setting description
42	00	Indoor unit
	01	Both

00: Sensor on the indoor unit is active.

01: Sensors on both indoor unit and wired remote controller are active.

*Remote controller sensor must be turned on by using the remote controller.

6) Remote controller custom code

(Only for wireless remote controller)

The indoor unit custom code can be changed.

Select the appropriate custom code.

(◆... Factory setting)

Function number	Setting value	Setting description
44	00	A
	01	B
	02	C
	03	D

7) External input control

"Operation/Stop" mode or "Forced stop" mode can be selected.

(◆. . .Factory setting)

Function number	Setting value	Setting description
46	00	Operation/Stop mode
	01	(Setting prohibited)
	02	Forced stop mode

8) Room temperature sensor switching (Aux.)

To use the temperature sensor on the wired remote controller only, change the setting to "Wired remote controller" (01). This function will only work if the function setting 42 is set at "Both" (01).

(◆. . .Factory setting)

Function number	Setting value	Setting description
48	00	Both
	01	Wired remote controller

9) Indoor unit fan control for energy saving for cooling

Enables or disables the power-saving function by controlling the indoor unit fan rotation when the outdoor unit is stopped during cooling operation.

(◆. . .Factory setting)

Function number	Setting value	Setting description
49	00	Disable
	01	Enable

00: When the outdoor unit is stopped, the indoor unit fan operates continuously following the setting on the remote controller.

01: When the outdoor unit is stopped, the indoor unit fan operates intermittently at a very low speed.

10) Room temperature control for wired remote controller sensor

Refer to Function 95, before performing this setting.

Depending on the installed environment, correction of the wired remote controller temperature sensor may be required.

Select the appropriate control setting according to the installed environment.

To change this setting, set Function 42 to Both "01".

Ensure that the Thermo Sensor icon is displayed on the remote controller screen.

(◆ . . .Factory setting)

Function number	Setting value	Setting description		
92 (For cooling)	93 (For heating)	00	No correction 0.0°F 0.0°C ◆	
		01	No correction 0.0°F 0.0°C	
		02	-1°F (-0.5°C)	More cooling Less heating
		03	-2°F (-1.0°C)	
		04	-3°F (-1.5°C)	
		05	-4°F (-2.0°C)	
		06	-5°F (-2.5°C)	
		07	-6°F (-3.0°C)	
		08	-7°F (-3.5°C)	
		09	-8°F (-4.0°C)	Less cooling More heating
		10	+1°F (+0.5°C)	
		11	+2°F (+1.0°C)	
		12	+3°F (+1.5°C)	
		13	+4°F (+2.0°C)	
		14	+5°F (+2.5°C)	
		15	+6°F (+3.0°C)	
		16	+7°F (+3.5°C)	
17	+8°F (+4.0°C)			

11) Heat Insulation condition (building insulation)

Heat insulation conditions differ according to the installed environment.

Standard insulation "00" allows system to rapidly respond to the cooling or heating load changes. High insulation "01" is when the heat insulation structure of the building is high and does not require system to rapidly respond to cooling or heating load changes.

When High insulation "01" is selected;

- Overheating (overcooling) is prevented at the start-up.
- All room temp. control settings (Function 30, 31, 92, 93) will reset to No correction [0.0°F (0.0°C)].

(◆ . . .Factory setting)

Function number	Setting value	Setting description	
95	00	Standard insulation	◆
	01	High insulation	

NOTE:

When changing Function 95, perform this setting before other Room temp. control settings (Function 30, 31, 92, 93). IF Function 95 is not set first, Room temperature control settings (Function 30, 31, 92, 93) will be reset and you must re-do them again.

■ REMOTE CONTROLLER CUSTOM CODE SETTING

Use the following steps to select the custom code of the remote controller.

1. (Note that the air conditioner cannot receive a signal if the air conditioner has not been set for the matching custom code.) Press the START/STOP button until only the clock is displayed on the remote controller display.
2. Press the MODE button for at least five seconds to display the current custom code (initially set to **A**).
3. Press the SET TEMP. (\wedge) (\vee) button to change the custom code between **A** \rightarrow **b** \rightarrow **c** \rightarrow **d**. Match the code on the display to the air conditioner custom code.
4. Press the MODE button again to return to the clock display. The custom code will be changed.

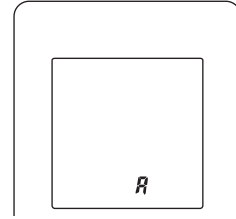

If no buttons are pressed within 30 seconds after the custom code is displayed, the system returns to the original clock display. In this case, start again from step 1.

The air conditioner custom code is set to A prior to shipment.

The remote controller resets to custom code A when the batteries in the remote controller are replaced. If you use a custom code other than custom code A, reset the custom code after replacing the batteries. If you do not know the air conditioner custom code setting, try each of the custom codes (**A** \rightarrow **b** \rightarrow **c** \rightarrow **d**) until you find the code which operates the air conditioner.

■ REMOTE CONTROLLER TEMPERATURE UNIT

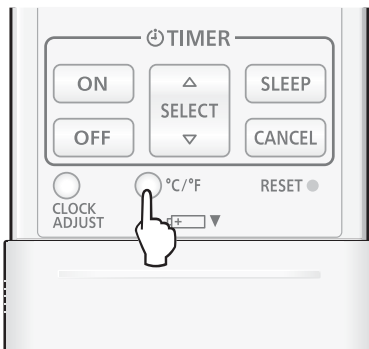

To change the temperature unit:

- Press the °C / °F switching button to select the preferred temperature unit. (Factory setting is °F.)

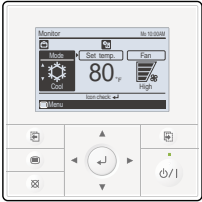

13. OPTIONAL PARTS

13-1. CONTROLLER

Exterior	Parts name	Model No.	Summary
	Wired remote controller	RXRVNUM	Large and full-dot liquid crystal screen, wide and large keys easy to press, user-intuitive arrow key.
	Wired remote controller	RXRNNUM	The room temperature can be controlled by detecting the temperature accurately with built-in thermo sensor.
	Simple remote controller	RXRSNUM	Compact remote controller concentrates on the basic functions such as Start/Stop, Fan Control, Temperature Setting and Operation mode.

13-2. OTHERS

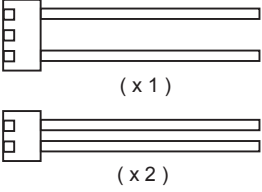
Exterior	Parts name	Model No.	Summary
	External connect kit	RXXWZXZ5	Required when external device is connected.

2. OUTDOOR UNIT

SINGLE TYPE :

ROSH09AFFJ

ROSH12AFFJ

ROSH15AFFJ

CONTENTS

2. OUTDOOR UNIT

1. SPECIFICATIONS.....	02 - 01
2. DIMENSIONS	02 - 02
3. REFRIGERANT CIRCUIT	02 - 03
4. WIRING DIAGRAMS.....	02 - 05
5. CAPACITY COMPENSATION RATE FOR PIPE LENGTH AND HEIGHT DIFFERENCE	02 - 07
6. ADDITIONAL CHARGE CALCULATION.....	02 - 09
7. AIRFLOW	02 - 10
8. OPERATION NOISE.....	02 - 12
8-1. NOISE LEVEL CURVE	02 - 12
8-2. SOUND LEVEL CHECK POINT	02 - 14
9. ELECTRIC CHARACTERISTICS.....	02 - 15
10. SAFETY DEVICES	02 - 16

1. SPECIFICATIONS

Type			INVERTER HEAT PUMP			
Model name			ROSH09AFFJ	ROSH12AFFJ	ROSH15AFFJ	
Power source			208 / 230V ~ 60Hz			
Available voltage range			187 - 253V ~ 60Hz			
Starting current			A	4.1	6.7	7.0
Fan	Airflow rate	Cooling	CFM (m ³ /h)	1207 (2050)	1457 (2475)	1457 (2475)
		Heating		1207 (2050)	1207 (2050)	1386 (2355)
	Type × Q'ty	Propeller fan × 1				
Motor output			W	115		
Sound pressure level		Cooling	dB (A)	49	53	54
		Heating		50	52	54
Heat exchanger type		Dimensions (H × W × D)	in.	23-1/8 × 34-11/16 × 1-7/16		
			mm	588 × 881 × 36.4		
		Fin pitch	FPI	20		
		Rows × Stages	2 × 28			
		Pipe type	Copper			
		Fin Type	Aluminum			
Compressor	Type × Q'ty		Rotary × 1			
	Motor output		W	850	1000	
Refrigerant		Type	R410A			
		Charge	lbs.oz.	2lbs.10oz.	2lbs.12oz.	
			kg	1.20	1.25	
Refrigerant oil		Type	FREOL α68SZ			
Enclosure		Material	Steel			
		Color	Beige Approximate color of MUNSELL 10YR7.5/1.0			
Dimensions (H × W × D)	Net		in.	24-7/16 × 31-1/8 × 11-7/16		
			mm	620 × 790 × 290		
	Gross		in.	28-1/16 × 37-3/16 × 15-9/16		
			mm	713 × 945 × 395		
Weight	Net	lbs.(kg)	84 (38)		86 (39)	
	Gross		93 (42)		95 (43)	
Connention pipe	Size	Liquid	in. (mm)	Ø 1/4 (Ø 6.35)		
		Gas		Ø 3/8 (Ø 9.52)	Ø 1/2 (Ø 12.7)	
	Method		Flare			
	Pre - charge length		ft. (m)	49 (15)		
	Max. length			66 (20)		
	Min. length			10 (3)		
Max. height difference		49 (15)				
Operation range		Cooling	°F (°C)	14 to 115 (-10 to 46)		
		Heating		-5 to 75 (-21 to 24)		

NOTE:

Specifications are based on the following conditions.

Cooling : Indoor temperature of 80°F (26.67°C) DB / 67°F (19.44°C) WB, and outdoor temperature of 95°F (35°C) DB / 75°F (23.9°C) WB.

Heating : Indoor temperature of 70°F (21.11°C) DB / 59°F (15°C) WB, and outdoor temperature of 47°F (8.33°C) DB / 43°F (6.11°C) WB.

Pipe length : 24ft.(7.5m), Height difference:0 m. (Outdoor unit - Indoor unit)

The protective function might work when using it outside the operation range.

2. DIMENSIONS

■MODEL: ROSH09AFFJ, ROSH12AFFJ, ROSH15AFFJ

Unit: in. (mm)

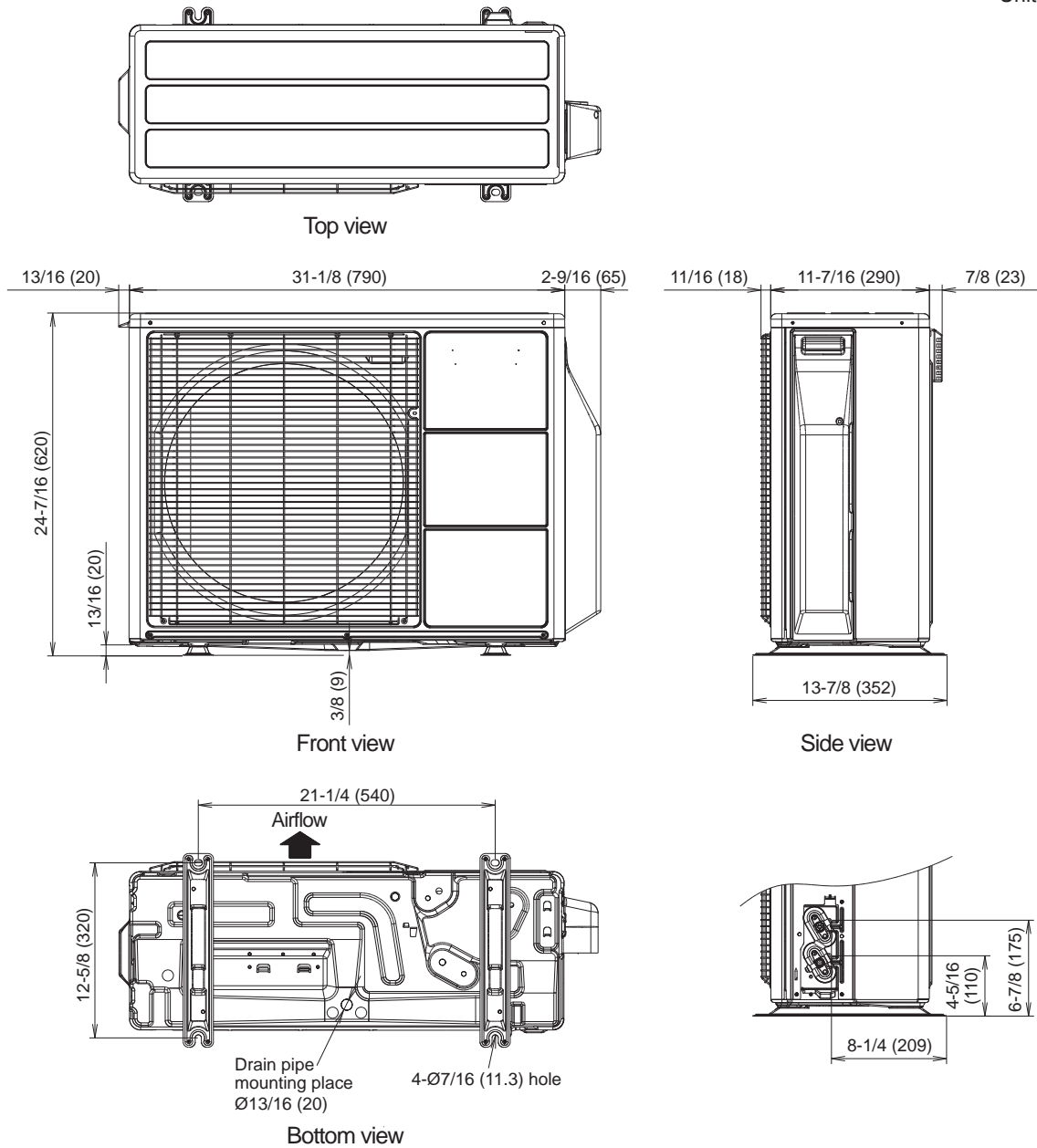

■ INSTALLATION PLACE

When there are obstacles at the back or front sides.

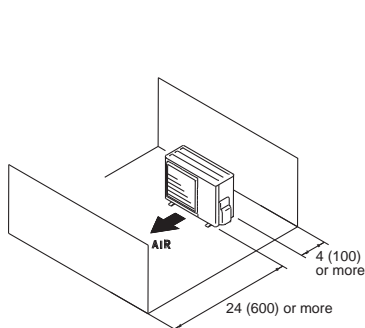

When there are obstacles at the back, side(s), and top.

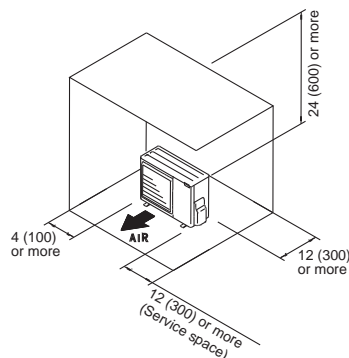

When there are obstacles at the back, side with the installation of more than one unit.

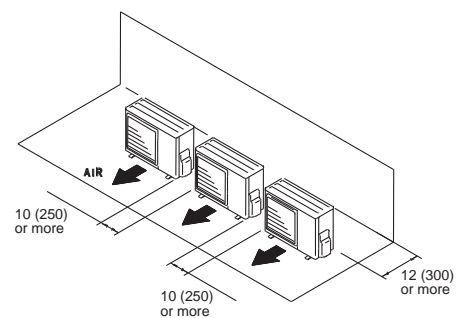

3. REFRIGERANT CIRCUIT

■MODEL: ROSH09AFFJ,ROSH12AFFJ

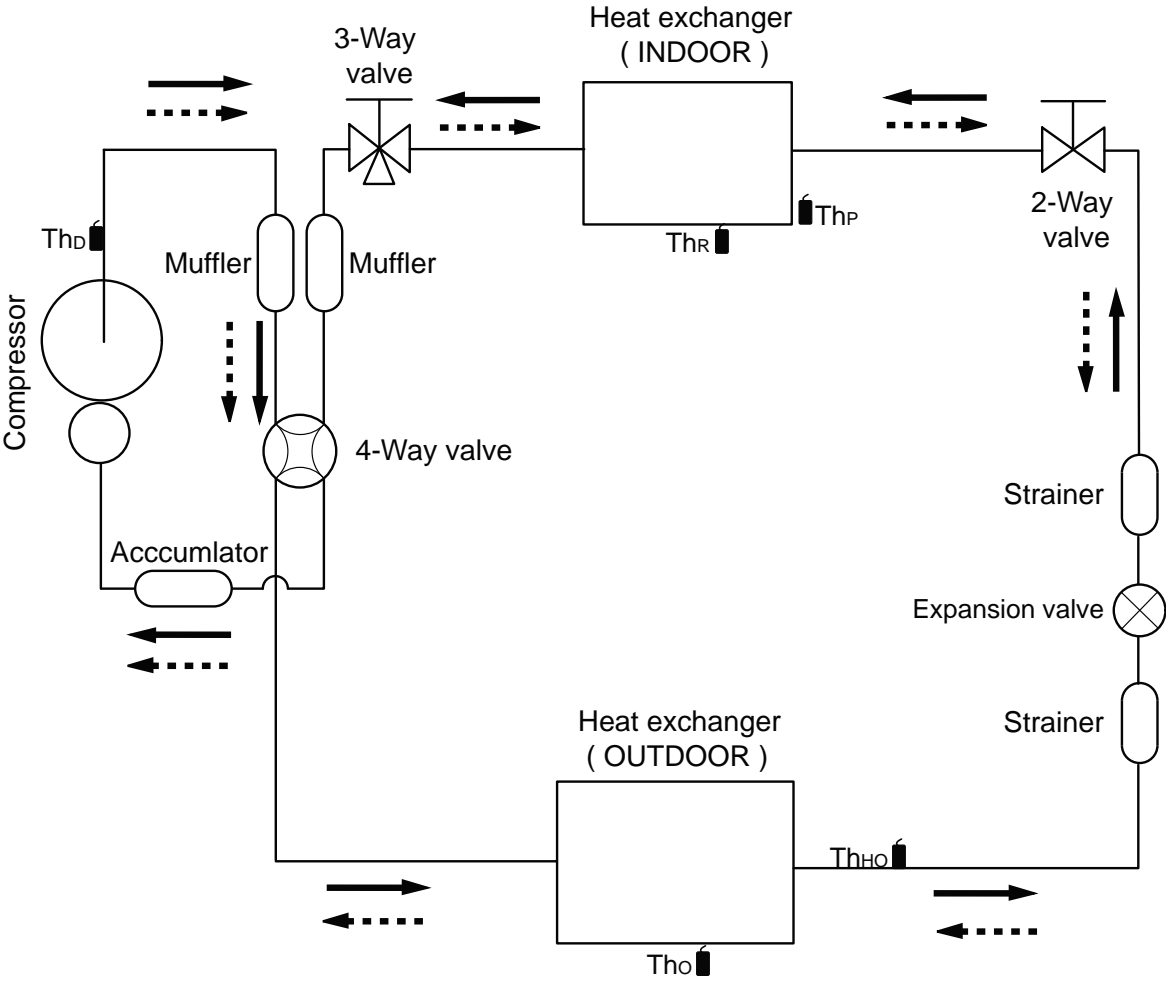

→ Cooling
 Heating

- Th_D : Thermistor (Discharge Temp.)
- Th_O : Thermistor (Outdoor Temp.)
- Th_{HO} : Thermistor (Heat Exchanger Out Temp.)
- Th_R : Thermistor (Room Temp.)
- Th_P : Thermistor (Pipe Temp.)

Refrigerant pipe diameter
 Liquid: 1/4" (6.35 mm)
 Gas: 3/8" (9.52 mm): 9/12RLFF

■ **MODEL: ROSH15AFFJ**

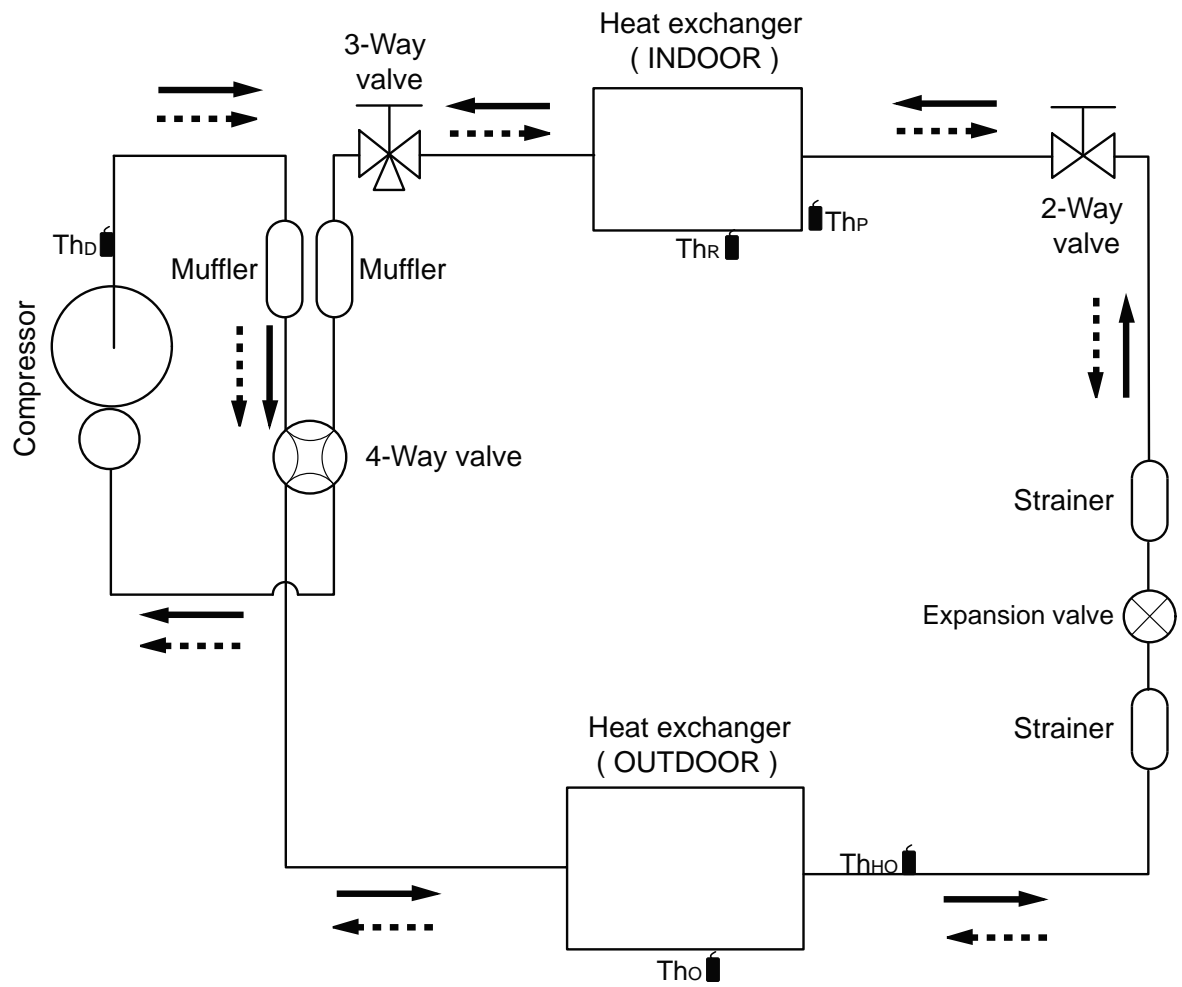

Cooling
 Heating

- ThD : Thermistor (Discharge Temp.)
- ThO : Thermistor (Outdoor Temp.)
- ThHO : Thermistor (Heat Exchanger Out Temp.)
- ThR : Thermistor (Room Temp.)
- ThP : Thermistor (Pipe Temp.)

Refrigerant pipe diameter
 Liquid: 1/4" (6.35 mm)
 Gas: 1/2" (12.70 mm): 15

4. WIRING DIAGRAMS

■MODEL: ROSH09AFFJ,ROSH12AFFJ

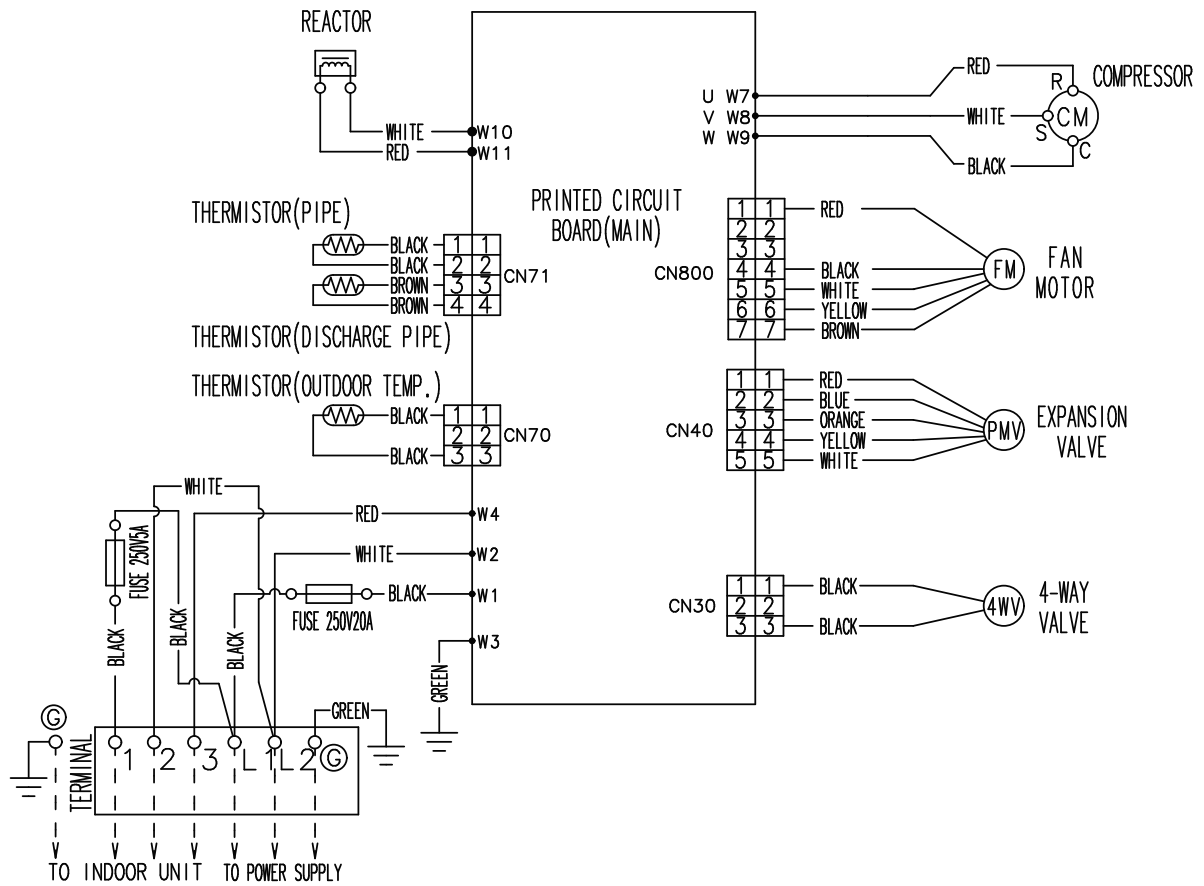

MODEL: ROSH15AFFJ

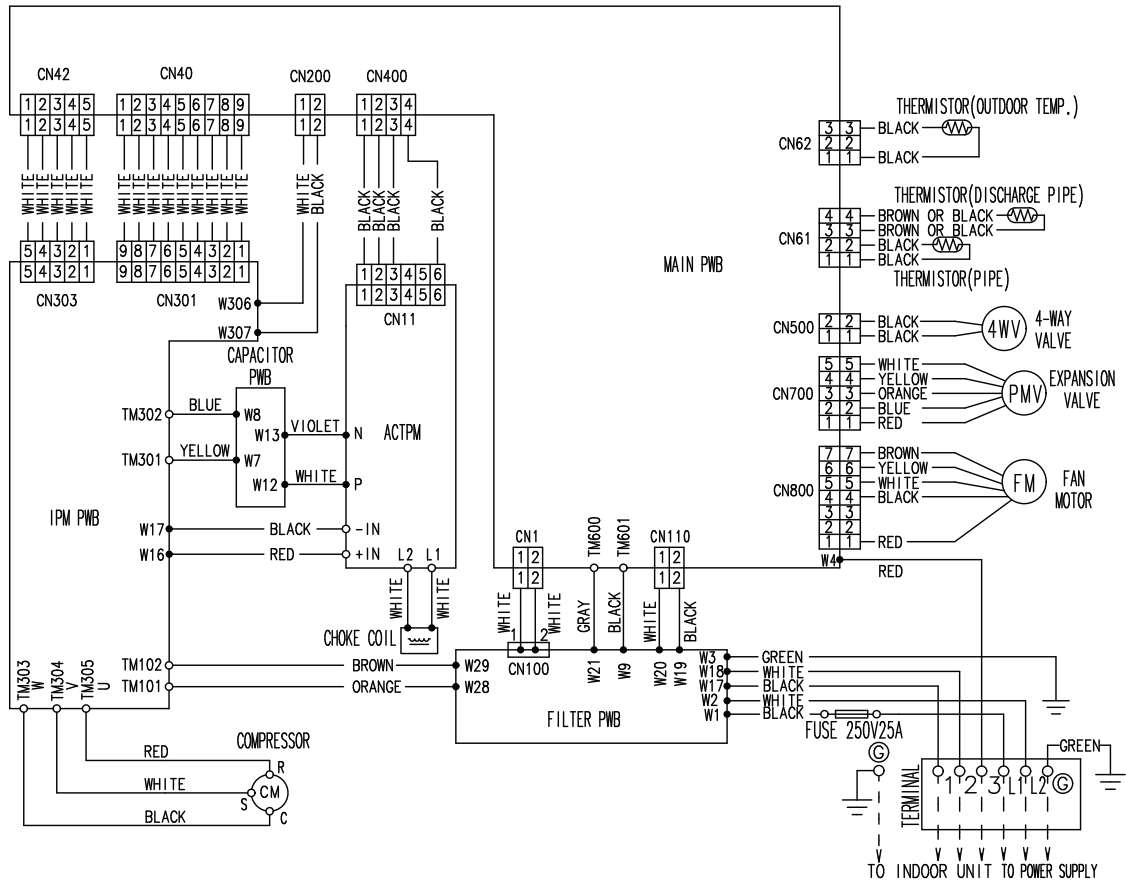

5. CAPACITY COMPENSATION RATE FOR PIPE LENGTH AND HEIGHT DIFFERENCE

■MODEL: ROSH09AFFJ,ROSH12AFFJ

COOLING				Pipe length (m)				
				5m	7.5m	10m	15m	20m
				17ft.	25ft.	33ft.	50ft.	67ft.
Height difference H	*1 Indoor unit is higher than outdoor unit.	15m	50ft.	-	-	-	0.893	0.909
		10m	33ft.	-	-	0.955	0.908	0.924
		7.5m	25ft.	-	0.975	0.959	0.912	0.928
		5m	17ft.	0.992	0.979	0.963	0.916	0.931
		0m	0ft.	1.000	0.987	0.970	0.923	0.939
	*2 Indoor unit is lower than outdoor unit	-5m	-17ft.	1.000	0.987	0.970	0.923	0.939
		-7.5m	-25ft.	-	0.987	0.970	0.923	0.939
		-10m	-33ft.	-	-	0.970	0.923	0.939
		-15m	-50ft.	-	-	-	0.923	0.939

HEATING				Pipe length (m)				
				5m	7.5m	10m	15m	20m
				17ft.	25ft.	33ft.	50ft.	67ft.
Height difference H	*1 Indoor unit is higher than outdoor unit.	15m	50ft.	-	-	-	0.956	0.938
		10m	33ft.	-	-	1.004	0.956	0.938
		7.5m	25ft.	-	1.013	1.004	0.956	0.938
		5m	17ft.	1.000	1.013	1.004	0.956	0.938
		0m	0ft.	1.000	1.013	1.004	0.956	0.938
	*2 Indoor unit is lower than outdoor unit	-5m	-17ft.	0.995	1.008	0.999	0.951	0.933
		-7.5m	-25ft.	-	1.005	0.997	0.948	0.931
		-10m	-33ft.	-	-	0.994	0.946	0.929
		-15m	-50ft.	-	-	-	0.937	0.919

Height difference H

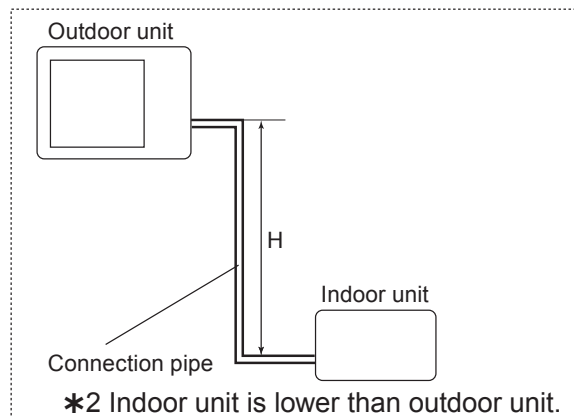
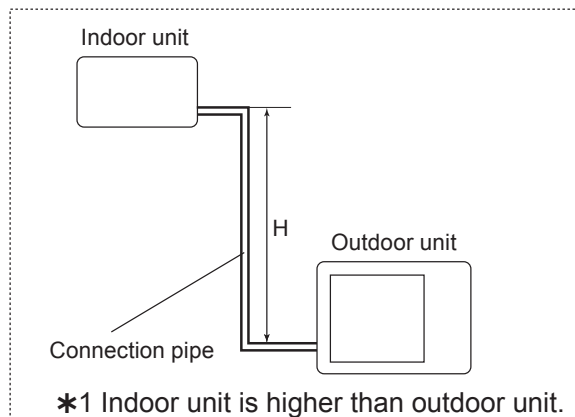

MODEL: ROSH15AFFJ

COOLING				Pipe length (m)				
				5m	7.5m	10m	15m	20m
				17ft.	25ft.	33ft.	50ft.	67ft.
Height difference H	*1 Indoor unit is higher than outdoor unit.	15m	50ft.	-	-	-	0.951	0.950
		10m	33ft.	-	-	0.979	0.967	0.966
		7.5m	25ft.	-	0.988	0.983	0.971	0.970
		5m	17ft.	0.994	0.992	0.987	0.975	0.974
	*2 Indoor unit is lower than outdoor unit	0m	0ft.	1.002	1.000	0.995	0.983	0.982
		-5m	-17ft.	1.002	1.000	0.995	0.983	0.982
		-7.5m	-25ft.	-	1.000	0.995	0.983	0.982
		-10m	-33ft.	-	-	0.995	0.983	0.982
		-15m	-50ft.	-	-	-	0.983	0.982

HEATING				Pipe length (m)				
				5m	7.5m	10m	15m	20m
				17ft.	25ft.	33ft.	50ft.	67ft.
Height difference H	*1 Indoor unit is higher than outdoor unit.	15m	50ft.	-	-	-	0.994	0.979
		10m	33ft.	-	-	1.012	0.994	0.979
		7.5m	25ft.	-	1.000	1.012	0.994	0.979
		5m	17ft.	0.969	1.000	1.012	0.994	0.979
	*2 Indoor unit is lower than outdoor unit	0m	0ft.	0.969	1.000	1.012	0.994	0.979
		-5m	-17ft.	0.964	0.995	1.007	0.989	0.974
		-7.5m	-25ft.	-	0.993	1.004	0.986	0.972
		-10m	-33ft.	-	-	1.002	0.984	0.969
		-15m	-50ft.	-	-	-	0.974	0.959

Height difference H

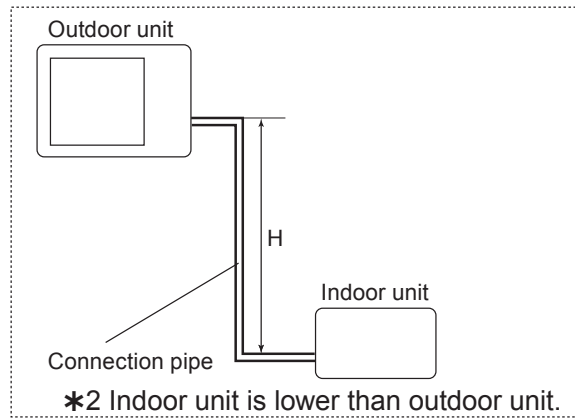
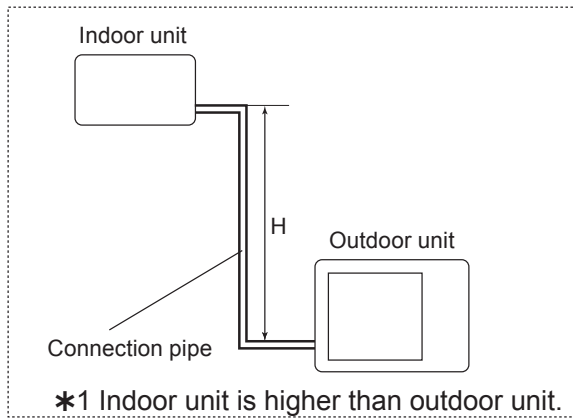

6. ADDITIONAL CHARGE CALCULATION ■

MODEL: ROSH09AFFJ,ROSH12AFFJ

Refrigerant type		R410A
Refrigerant amount	lbs. oz.	2lbs.10oz.
	g	1200

● Refrigerant charge

Pipe length	ft.	49 or less	66 (MAX)	0.22oz./ft. (20g/m)
	m	15 or less	20 (MAX)	
Additional charge	oz.	0	+3.5	
	g	0	+100	

■MODEL: ROSH15AFFJ

Refrigerant type		R410A
Refrigerant amount	lbs. oz.	2lbs.12oz.
	g	1250

● Refrigerant charge

Pipe length	ft.	49 or less	66 (MAX)	0.22oz./ft. (20g/m)
	m	15 or less	20 (MAX)	
Additional charge	oz.	0	+3.5	
	g	0	+100	

7. AIRFLOW

■MODEL: ROSH09AFFJ

●Cooling

Number of rotations (r.p.m.)	Airflow	
	870	m ³ /h
l/s		569
CFM		1207

●Heating

Number of rotations (r.p.m.)	Airflow	
	870	m ³ /h
l/s		569
CFM		1207

■MODEL: ROSH12AFFJ

●Cooling

Number of rotations (r.p.m.)	Airflow	
	1050	m ³ /h
l/s		688
CFM		1457

●Heating

Number of rotations (r.p.m.)	Airflow	
	870	m ³ /h
l/s		569
CFM		1207

■MODEL: ROSH15AFFJ

●Cooling

Number of rotations (r.p.m.)	Airflow	
	1050	m ³ /h
l/s		688
CFM		1457

●Heating

Number of rotations (r.p.m.)	Airflow	
	1000	m ³ /h
l/s		654
CFM		1386

8. OPERATION NOISE

8-1. NOISE LEVEL CURVE

MODEL: ROSH09AFFJ

Cooling

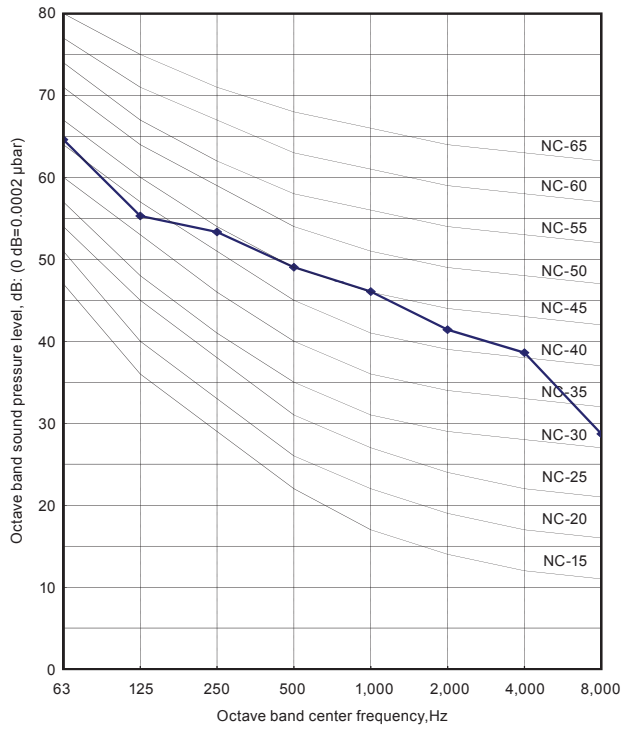

Heating

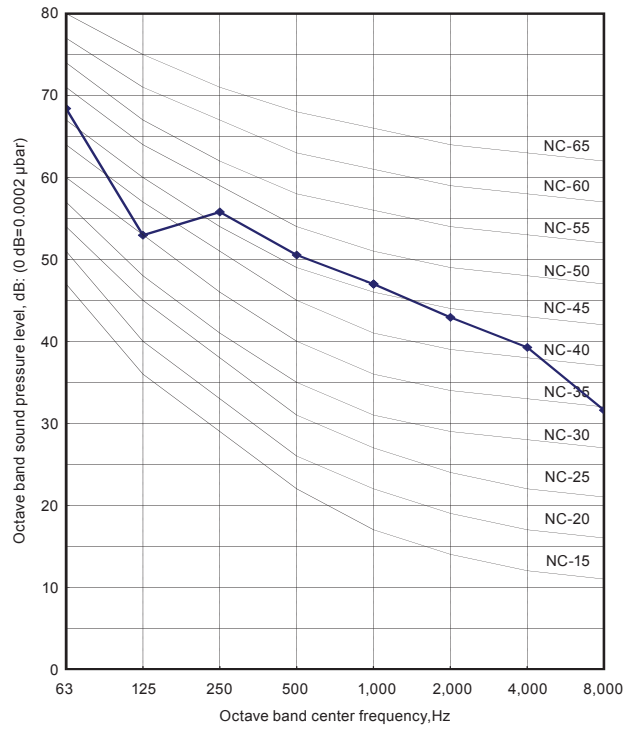

MODEL: ROSH12AFFJ

Cooling

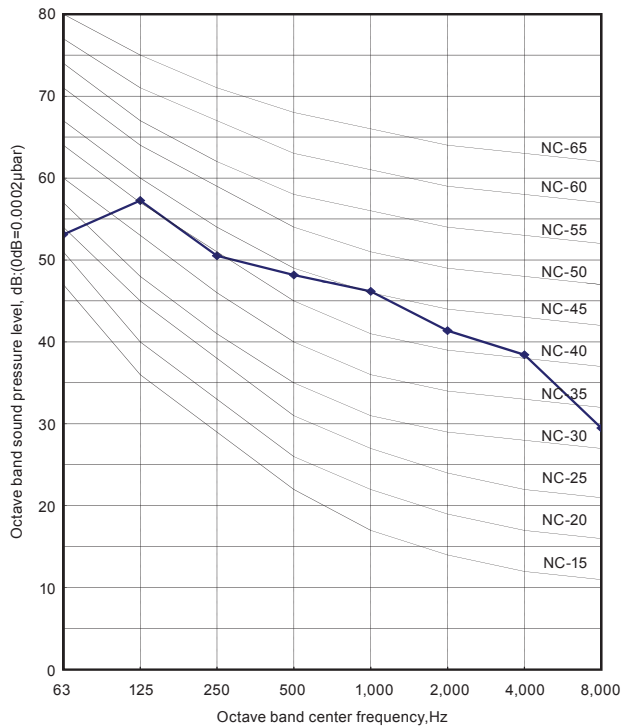

Heating

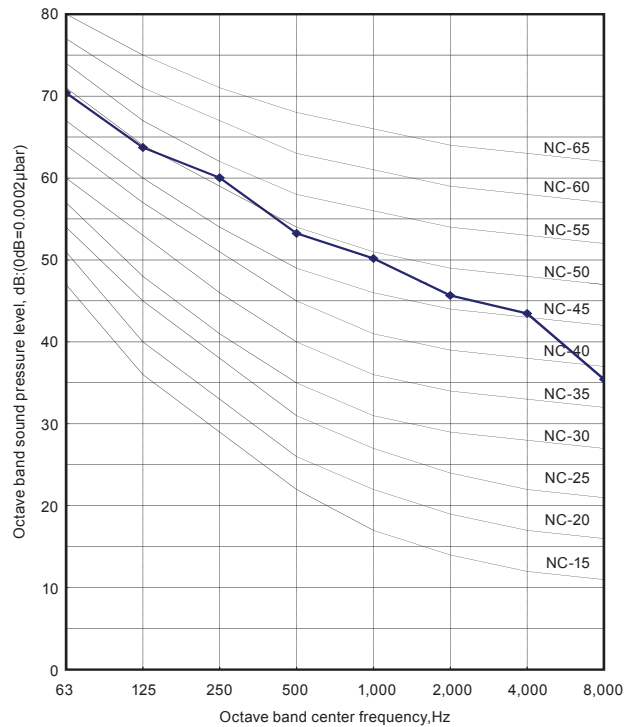

MODEL: ROSH15AFFJ

● Cooling

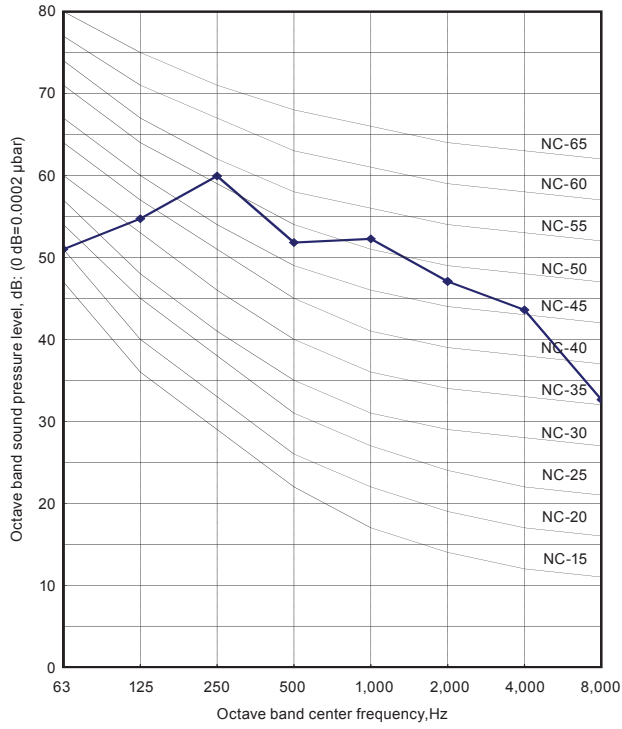

● Heating

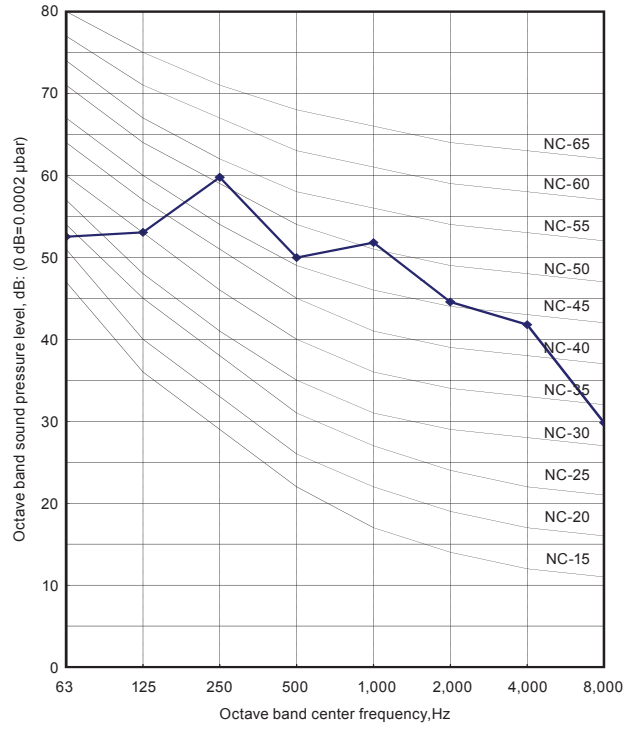

8-2. SOUND LEVEL CHECK POINT

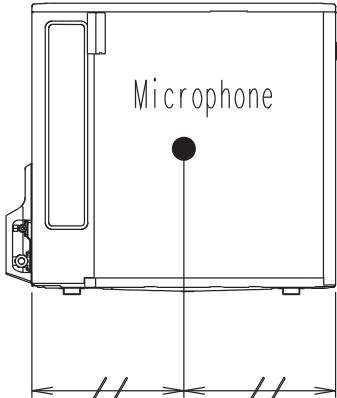
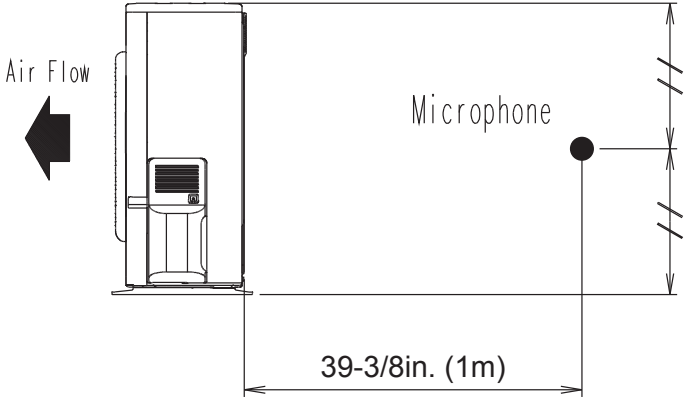

9. ELECTRIC CHARACTERISTICS

Model name			ROSH09AFFJ	ROSH12AFFJ	ROSH15AFFJ
Power supply	Voltage	V	208 / 230 ~		
	Frequency	Hz	60		
MCA		A	10.8		13.8
Starting Current		A	4.1	6.7	7.0
*1) Wiring Spec.:	MAX. CKT. BKR	A	15		20
	Power Cable	AWG	14		12

*1) Wiring Spec.:

Selected Sample

(Selected based on Japan Electrotechnical Standard and Codes Committee E0005)

MCA: Min Circuit Amp(Calculation based on UL1995)

MAX. CKT. BKR: Maximum Circuit Breaker

10. SAFETY DEVICES

	Protection form	Model		
		ROSH09AFFJ	ROSH15AFFJ	ROSH15AFFJ
Circuit protection	Current fuse (Near the terminal)	250V 20A		250V 25A
		250V 5A		
	Current fuse (Main printed circuit board)	250V 15A		250V 10A
		250V 3.15A		250V 3.15A
Fan motor protection	Thermal protection program	OFF: 212 ± 27 °F (100 ± 15 °C) ON: 203 ± 18 °F (95 ± 10 °C)		
Compressor protection	Thermal protection program (Discharge temp.)	OFF: 230 °F (110 °C) ON: After 7 minutes		