

# INSTALLATION INSTRUCTIONS

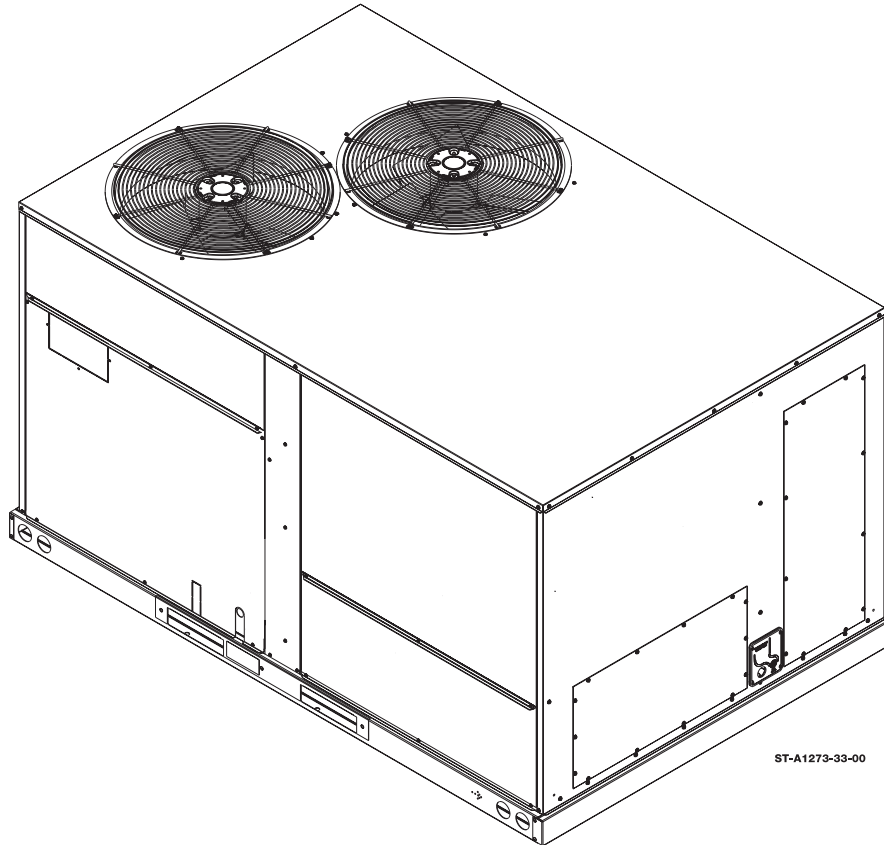
## PACKAGE HEAT PUMPS FEATURING

## INDUSTRY STANDARD R410A REFRIGERANT



### RHPD SERIES 7.5 & 10 TON [26.4 & 35.2 kW]

### 60 Hz MODELS



ST-A1273-33-00



Recognize this symbol as an indication of Important Safety Information!

## DO NOT DESTROY

PLEASE READ CAREFULLY AND KEEP IN A SAFE PLACE FOR FUTURE REFERENCE.

### ▲ WARNING

THESE INSTRUCTIONS ARE INTENDED AS AN AID TO QUALIFIED, LICENSED SERVICE PERSONNEL FOR PROPER INSTALLATION, ADJUSTMENT AND OPERATION OF THIS UNIT. READ THESE INSTRUCTIONS THOROUGHLY BEFORE ATTEMPTING INSTALLATION OR OPERATION. FAILURE TO FOLLOW THESE INSTRUCTIONS MAY RESULT IN IMPROPER INSTALLATION, ADJUSTMENT, SERVICE OR MAINTENANCE POSSIBLY RESULTING IN FIRE, ELECTRICAL SHOCK, PROPERTY DAMAGE, PERSONAL INJURY OR DEATH.



[ ] Designates metric conversions

92-106169-01-01

# TABLE OF CONTENTS

I. Safety Information	3
II. Introduction	4
III. Checking Product Received	4
IV. Equipment Protection	4
V. Specifications	4
A. General	4
B. Major Components	5
C. R-410A Refrigerant	5
Unit Dimensions	6-7
General Data	8-35
Electrical Data Tables	36-47
VI. Installation	48
A. General	48
1. Pre-Installation Check Points	48
2. Location	48
B. Outside Slab Installation	48
C. Clearances	48
D. Rooftop Installation	49
VII. Ductwork	49
VIII. Filters	50
IX. Conversion Procedure	50
X. Condensate Drain	50
XI. Condensate Drain, Outdoor Coil	51
XII. Electrical Wiring	51
A. Power Wiring	51
RXJJ-Series Heater Kit Installation Instructions	52-57
B. Control Wiring	57
C. Internal Wiring	57
D. Grounding	58
E. Thermostat	58
XIII. Indoor Air Flow Data	58
XIV. Crankcase Heat	58
XV. Pre-Start Check	58
XVI. Startup	59
XVII. Operation	59
Cooling Mode	59
Heating Mode	59
XVIII. Auxiliary Heat	59
XIX. Demand Defrost Control	59-61
XX. Airflow Data Tables	62-67
Heater Kit Characteristics	68-81
Troubleshooting Chart	82
Wiring Diagrams	83-94
Charge Charts	95-100



**▲ NOTICE**

**BREAK-IN PERIOD**

PRIOR TO AGENCY TESTING, RUN THE COMPRESSOR FOR 16 HOURS AT 115°F OUTDOOR AMBIENT TEMPERATURE AND 80° DRY BULB/75° WET BULB INDOOR AMBIENT TEMPERATURE.

**▲ NOTICE**

**EFFICIENCY TESTING NOTICE**

FOR PURPOSES OF VERIFYING OR TESTING EFFICIENCY RATINGS, THE TEST PROCEDURE IN TITLE 10 PART 431 APPENDIX A TO SUBPART F (UNIFORM TEST METHOD FOR MEASURING THE ENERGY CONSUMPTION OF SMALL, LARGE, AND VERY LARGE COMMERCIAL PACKAGE AIR CONDITIONING AND HEATING EQUIPMENT), AND THE CLARIFYING PROVISIONS PROVIDED IN THE AHRI OPERATIONS MANUALS FOR UNITARY LARGE EQUIPMENT 340/360, 365 THAT WERE APPLICABLE AT THE DATE OF MANUFACTURE SHOULD BE USED FOR TEST SET UP AND PERFORMANCE.

**I. SAFETY INFORMATION**

**▲ WARNING**

THE MANUFACTURER'S WARRANTY DOES NOT COVER ANY DAMAGE OR DEFECT TO THE AIR CONDITIONER CAUSED BY THE ATTACHMENT OR USE OF ANY COMPONENTS, ACCESSORIES OR DEVICES (OTHER THAN THOSE AUTHORIZED BY THE MANUFACTURER) INTO, ONTO OR IN CONJUNCTION WITH THE AIR CONDITIONER. YOU SHOULD BE AWARE THAT THE USE OF UNAUTHORIZED COMPONENTS, ACCESSORIES OR DEVICES MAY ADVERSELY AFFECT THE OPERATION OF THE AIR CONDITIONER AND MAY ALSO ENDANGER LIFE AND PROPERTY. THE MANUFACTURER DISCLAIMS ANY RESPONSIBILITY FOR SUCH LOSS OR INJURY RESULTING FROM THE USE OF SUCH UNAUTHORIZED COMPONENTS, ACCESSORIES OR DEVICES.

**▲ WARNING**

DISCONNECT ALL POWER TO THE UNIT BEFORE STARTING MAINTENANCE. FAILURE TO DO SO CAN RESULT IN SEVERE ELECTRICAL SHOCK OR DEATH.

**▲ CAUTION**

R-410A systems operate at higher pressures than R-22 systems. Do not use R-22 service equipment or components on R-410A equipment.

**▲ WARNING**

DO NOT, UNDER ANY CIRCUMSTANCES, CONNECT RETURN DUCTWORK TO ANY OTHER HEAT PRODUCING DEVICE SUCH AS A FIREPLACE INSERT, STOVE, ETC. UNAUTHORIZED USE OF SUCH DEVICES MAY RESULT IN FIRE, CARBON MONOXIDE POISONING, EXPLOSION, PROPERTY DAMAGE, SEVERE PERSONAL INJURY OR DEATH.

**▲ WARNING**

THE UNIT MUST BE PERMANENTLY GROUNDED. A GROUNDING LUG IS PROVIDED IN THE ELECTRIC HEAT ACCESS AREA FOR A GROUND WIRE. FAILURE TO GROUND THIS UNIT CAN RESULT IN FIRE OR ELECTRICAL SHOCK CAUSING PROPERTY DAMAGE, SEVERE PERSONAL INJURY OR DEATH.

**▲ WARNING**

ONLY ELECTRIC HEATER KITS SUPPLIED BY THIS MANUFACTURER AS DESCRIBED IN THIS PUBLICATION HAVE BEEN DESIGNED, TESTED, AND EVALUATED FOR USE WITH THIS UNIT. USE OF ANY OTHER MANUFACTURED ELECTRIC HEATERS INSTALLED WITHIN THIS UNIT MAY CAUSE HAZARDOUS CONDITIONS RESULTING IN PROPERTY DAMAGE, FIRE, BODILY INJURY OR DEATH.

## II. INTRODUCTION

### ▲ WARNING

THE MANUFACTURER'S WARRANTY DOES NOT COVER ANY DAMAGE OR DEFECT TO THE HEAT PUMP CAUSED BY THE ATTACHMENT OR USE OF ANY COMPONENTS, ACCESSORIES OR DEVICES (OTHER THAN THOSE AUTHORIZED BY THE MANUFACTURER) INTO, ONTO OR IN CONJUNCTION WITH THE HEAT PUMP. YOU SHOULD BE AWARE THAT THE USE OF UNAUTHORIZED COMPONENTS, ACCESSORIES OR DEVICES MAY ADVERSELY AFFECT THE OPERATION OF THE HEAT PUMP AND MAY ALSO ENDANGER LIFE AND PROPERTY. THE MANUFACTURER DISCLAIMS ANY RESPONSIBILITY FOR SUCH LOSS OR INJURY RESULTING FROM THE USE OF SUCH UNAUTHORIZED COMPONENTS, ACCESSORIES OR DEVICES.

This booklet contains the installation and operating instructions for your package heat pump. There are a few precautions that should be taken to derive maximum satisfaction from it. Improper installation can result in unsatisfactory operation or dangerous conditions.

Read this booklet and any instructions packaged with separate equipment required to make up the system prior to installation. Give this booklet to the owner and explain its provisions. The owner should retain this booklet for future reference.

## III. CHECKING PRODUCT RECEIVED

Upon receiving the unit, inspect it for any damage from shipment. Claims for damage, either shipping or concealed, should be filed immediately with the shipping company. Check the unit model number, heating size, electrical characteristics, and accessories to determine if they are correct.

## IV. EQUIPMENT PROTECTION FROM THE ENVIRONMENT

The metal parts of this unit may be subject to rust or deterioration in adverse environmental conditions. This oxidation could shorten the equipment's useful life. Salt spray, fog or mist in seacoast areas, sulphur or chlorine from lawn watering systems, and various chemical contaminants from industries such as paper mills and petroleum refineries are especially corrosive.

**If the unit is to be installed in an area where contaminants are likely to be a problem, special attention should be given to the equipment location and exposure.**

1. Avoid having lawn sprinkler heads spray direction on the unit cabinet.
2. In coastal areas, locate the unit on the side of the building away from the waterfront.
3. Shielding provided by a fence or shrubs may give some protection.

**Regular maintenance will reduce the buildup of contaminants and help to protect the unit's finish.**

### ▲ WARNING

DISCONNECT ALL POWER TO THE UNIT BEFORE STARTING MAINTENANCE. FAILURE TO DO SO CAN RESULT IN SEVERE ELECTRICAL SHOCK OR DEATH.

1. Frequent washing of the cabinet, fan blade and coil with fresh water will remove most of the salt or other contaminants that build up on the unit.
2. Regular cleaning and waxing of the cabinet with a good automobile polish will provide some protection.
3. A good liquid cleaner may be used several times a year to remove matter that will not wash off with water.

Several different types of protective coatings are offered in some areas. These coatings may provide some benefit, but the effectiveness of such coating materials cannot be verified by the equipment manufacturer.

**The best protection is frequent cleaning, maintenance and minimal exposure to contaminants.**

## V. SPECIFICATIONS

### A. GENERAL

The Packaged Heat Pump is available without auxiliary heat or with 15, 20, 30 or 40 kW electric heat. Cooling and heating capacities of 7½, and 10 nominal tons are available. Units are convertible from horizontal supply and return to bottom supply and return by relocation of supply and return air access panels. See cover installation detail.

The units are weatherized for mounting outside of the building.

The information on the rating plate is in compliance with the FTC and DOE rating for single phase units. The following information is for three phase units which **are not** covered under the DOE certification program.

1. The efficiency rating of this unit is a product thermal efficiency rating determined under continuous operating conditions independent of any installed system.

### B. MAJOR COMPONENTS

The unit includes a hermetically-sealed refrigerating system (consisting of a compressor, condenser coil, evaporator coil biflow thermal expansion valve, reversing valve), a circulation air blower, a condenser fan, and all necessary internal electrical wiring. The cooling system of these units is factory-evacuated, charged and performance tested. Refrigerant amount and type are indicated on rating plate.

### C. R-410A REFRIGERANT

All units are factory charged with R-410A refrigerant.

1. Specification of R-410A:

**Application:** R-410A is not a drop-in replacement for R-22; equipment designs must accommodate its higher pressures. It cannot be retrofitted into R-22 units.

**Pressure:** The pressure of R-410A is approximately 60% (1.6 times) greater than R-22. Recovery and recycle equipment, pumps, hoses and the like need to have design pressure ratings appropriate for R-410A. *Manifold sets need to range up to 800 psig high-side and 250 psig low-side with a 550 psig low-side retard. Hoses need to have a service pressure rating of 800 psig. Recovery cylinders need to have a 400 psig service pressure rating.* DOT 4BA400 or DOT BW400.

**Combustibility:** At pressures above 1 atmosphere, mixture of R-410A and air can become combustible. R-410A and air should never be mixed in tanks or supply lines, or be allowed to accumulate in storage tanks. Leak checking should never be done with a mixture of R-410A and air. Leak checking can be performed safely with nitrogen or a mixture of R-410A and nitrogen.

2. Quick Reference Guide For R-410A

- R-410A refrigerant operates at approximately 60% higher pressure (1.6 times) than R-22. Ensure that servicing equipment is designed to operate with R-410A.
- R-410A refrigerant cylinders are pink.
- R-410A, as with other HFC's is only compatible with POE oils.
- Vacuum pumps will not remove moisture from POE oil.
- R-410A systems are to be charged with liquid refrigerants.

Prior to March 1999, R-410A refrigerant cylinders had a dip tube. These cylinders should be kept upright for equipment charging. Post March 1999 cylinders do not have a dip tube and should be inverted to ensure liquid charging of the equipment.

- Do not install a suction line filter drier in the liquid line.
- A liquid line filter drier is standard on every unit.
- Desiccant (drying agent) must be compatible for POE oils and R-410A.

### 3. Thermostatic Expansion Valve (TXV)

The Bi-Flow TXV is specifically designed to operate with R-410A heat pumps. **Replacement of the TXV should only be made with the factory specified bi-flow R-410A valve. Do not use an R-22 TXV.**

### 4. Tools Required For Installing & Servicing R-410A Models

Manifold Sets:

- Up to 800 PSIG High side
- Up to 250 PSIG Low Side
- 550 PSIG Low Side Retard

Manifold Hoses:

- Service Pressure Rating of 800 PSIG

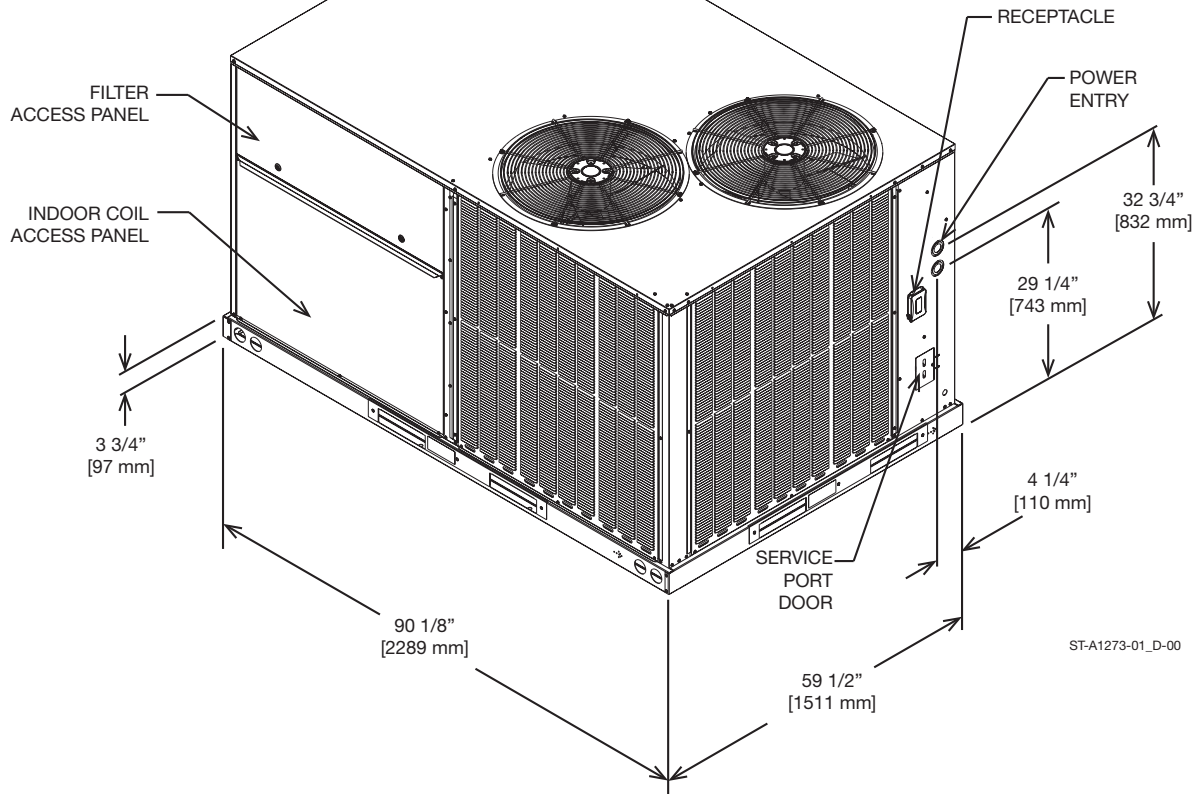
Recovery Cylinders:

- 400 PSIG Pressure Rating
- Dept. of Transportation 4BA400 or BW400

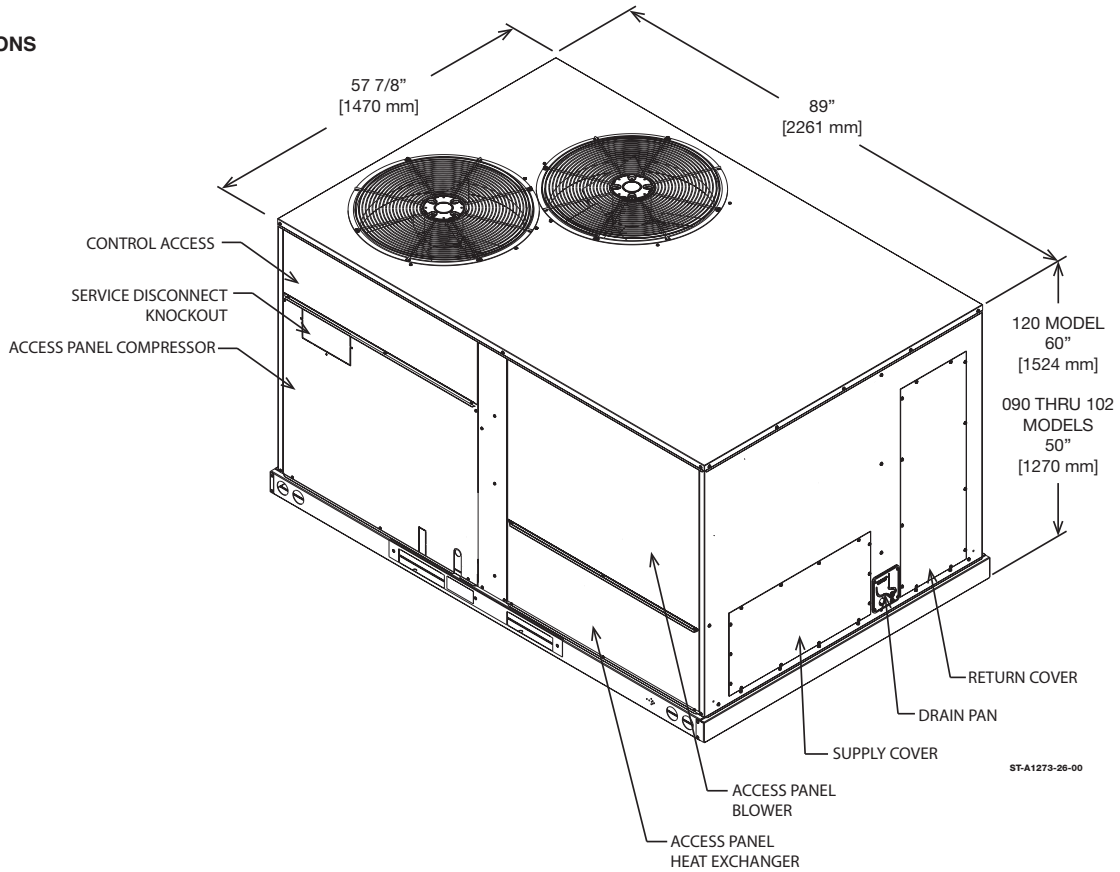
#### **▲ CAUTION**

R-410A systems operate at higher pressures than R-22 systems. Do not use R-22 service equipment or components on R-410A equipment.

**FIGURE 1**  
UNIT DIMENSIONS AND ACCESS LOCATIONS

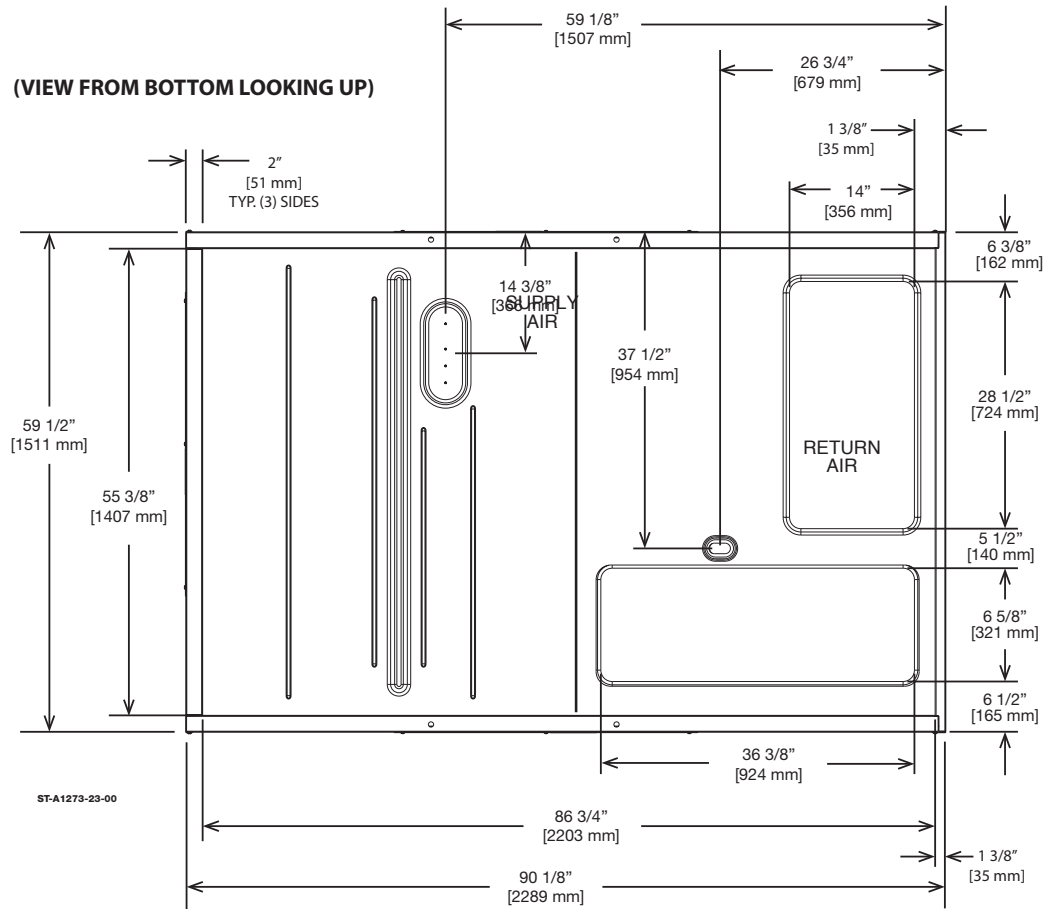


**FIGURE 2**  
UNIT DIMENSIONS

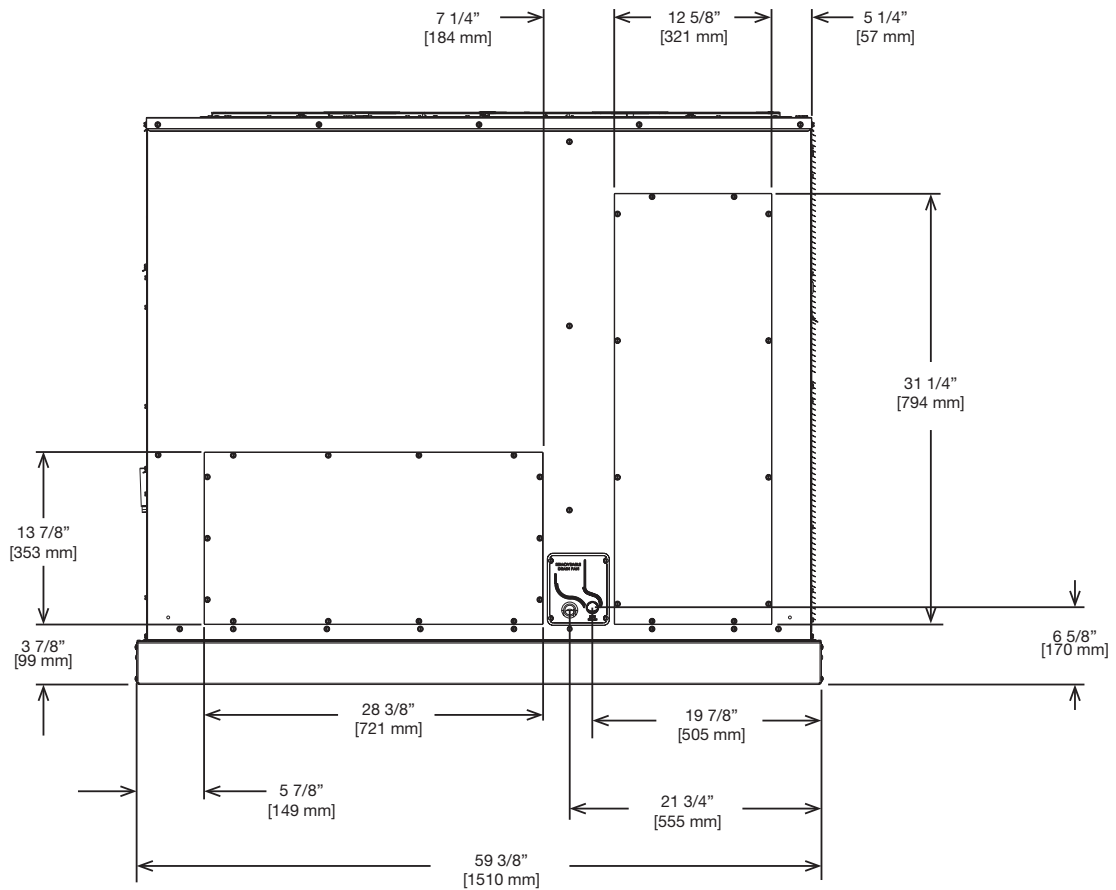


**FIGURE 3  
BOTTOM VIEW**

(VIEW FROM BOTTOM LOOKING UP)



**FIGURE 4  
REAR VIEW**



## GENERAL DATA

Model -HPDZR Series	090ACA	090ACB	090ACC	090ADA
Cooling Performance <sup>1</sup>				Continued ->
Gross Cooling Capacity Btu [kW]	89,000 [26.08]	89,000 [26.08]	89,000 [26.08]	89,000 [26.08]
EER/SEER <sup>2</sup>	11/NA	11/NA	11/NA	11/NA
Nominal CFM/AHRI Rated CFM [L/s]	3000/3030 [1416/1430]	3000/3030 [1416/1430]	3000/3030 [1416/1430]	3000/3030 [1416/1430]
AHRI Net Cooling Capacity Btu [kW]	86,000 [25.2]	86,000 [25.2]	86,000 [25.2]	86,000 [25.2]
Net Sensible Capacity Btu [kW]	62,800 [18.4]	62,800 [18.4]	62,800 [18.4]	62,800 [18.4]
Net Latent Capacity Btu [kW]	23,200 [6.8]	23,200 [6.8]	23,200 [6.8]	23,200 [6.8]
IEER <sup>3</sup>	12.2	12.2	12.2	12.2
Net System Power kW	7.55	7.55	7.55	7.55
Heating Performance (Heat Pumps)				
High Temp. Btuh [kW] Rating	84,000 [24.6]	84,000 [24.6]	84,000 [24.6]	84,000 [24.6]
System Power KW / COP	6.84/3.3	6.84/3.3	6.84/3.3	6.84/3.3
Low Temp. Btuh [kW] Rating	48,000 [14.06]	48,000 [14.06]	48,000 [14.06]	48,000 [14.06]
System Power KW / COP	6.44/2.25	6.44/2.25	6.44/2.25	6.44/2.25
Compressor				
No./Type	1/Scroll	1/Scroll	1/Scroll	1/Scroll
Outdoor Sound Rating (dB) <sup>5</sup>	88	88	88	88
Outdoor Coil - Fin Type	Louvered	Louvered	Louvered	Louvered
Tube Type	MicroChannel	MicroChannel	MicroChannel	MicroChannel
MicroChannel Depth in. [mm]	1 [25.4]	1 [25.4]	1 [25.4]	1 [25.4]
Face Area sq. ft. [sq. m]	22.8 [2.12]	22.8 [2.12]	22.8 [2.12]	22.8 [2.12]
Rows / FPI [FPcm]	1 / 16 [6]	1 / 16 [6]	1 / 16 [6]	1 / 16 [6]
Refrigerant Control	TX Valves	TX Valves	TX Valves	TX Valves
Indoor Coil - Fin Type	Louvered	Louvered	Louvered	Louvered
Tube Type	MicroChannel	MicroChannel	MicroChannel	MicroChannel
MicroChannel Depth in. [mm]	1.26 [32]	1.26 [32]	1.26 [32]	1.26 [32]
Face Area sq. ft. [sq. m]	10.9 [1.01]	10.9 [1.01]	10.9 [1.01]	10.9 [1.01]
Rows / FPI [FPcm]	1 / 20 [8]	1 / 20 [8]	1 / 20 [8]	1 / 20 [8]
Refrigerant Control	TX Valves	TX Valves	TX Valves	TX Valves
Drain Connection No./Size in. [mm]	1/0.75 [19.05]	1/0.75 [19.05]	1/0.75 [19.05]	1/0.75 [19.05]
Outdoor Fan - Type	Propeller	Propeller	Propeller	Propeller
No. Used/Diameter in. [mm]	2/24 [609.6]	2/24 [609.6]	2/24 [609.6]	2/24 [609.6]
Drive Type/No. Speeds	Direct/1	Direct/1	Direct/1	Direct/1
CFM [L/s]	8000 [3775]	8000 [3775]	8000 [3775]	8000 [3775]
No. Motors/HP	2 at 1/2 HP	2 at 1/2 HP	2 at 1/2 HP	2 at 1/2 HP
Motor RPM	1075	1075	1075	1075
Indoor Fan - Type	FC Centrifugal	FC Centrifugal	FC Centrifugal	FC Centrifugal
No. Used/Diameter in. [mm]	1/15x15 [381x381]	1/15x15 [381x381]	1/15x15 [381x381]	1/15x15 [381x381]
Drive Type	Belt (Adjustable)	Belt (Adjustable)	Belt (Adjustable)	Belt (Adjustable)
No. Speeds	Single	Single	Single	Single
No. Motors	1	1	1	1
Motor HP	2	3	3	2
Motor RPM	1725	1725	1725	1725
Motor Frame Size	56	56	56	56
Filter - Type	Disposable	Disposable	Disposable	Disposable
Furnished	Yes	Yes	Yes	Yes
(NO.) Size Recommended in. [mm x mm x mm]	(4)2x20x20 [51x508x508]	(4)2x20x20 [51x508x508]	(4)2x20x20 [51x508x508]	(4)2x20x20 [51x508x508]
Refrigerant Charge Oz. [g]	179 [5075]	179 [5075]	179 [5075]	179 [5075]
Weights				
Net Weight lbs. [kg]	775 [352]	775 [352]	786 [357]	775 [352]
Ship Weight lbs. [kg]	814 [369]	814 [369]	825 [374]	814 [369]

### NOTES:

- Cooling Performance is rated at 95° F ambient, 80° F entering dry bulb, 67° F entering wet bulb. Gross capacity does not include the effect of fan motor heat. AHRI capacity is net and includes the effect of fan motor heat. Units are suitable for operation to ±20% of nominal cfm. Units are certified in accordance with the Unitary Air Conditioner Equipment certification program, which is based on AHRI Standard 210/240 or 360.
- EER and/or SEER are rated at AHRI conditions and in accordance with DOE test procedures.
- Integrated Part Load Value is rated in accordance with AHRI Standard 210/240 or 360. Units are rated at 80° F ambient, 80° F entering dry bulb, and 67° F entering wet bulb at AHRI rated cfm.
- Outdoor Sound Rating shown is tested in accordance with AHRI Standard 270.

## GENERAL DATA

Model -HPDZR Series	090ADB	090ADC	090AYA	090AYB
Cooling Performance <sup>1</sup>				Continued ->
Gross Cooling Capacity Btu [kW]	89,000 [26.08]	89,000 [26.08]	89,000 [26.08]	89,000 [26.08]
EER/SEER <sup>2</sup>	11/NA	11/NA	11/NA	11/NA
Nominal CFM/AHRI Rated CFM [L/s]	3000/3030 [1416/1430]	3000/3030 [1416/1430]	3000/3030 [1416/1430]	3000/3030 [1416/1430]
AHRI Net Cooling Capacity Btu [kW]	86,000 [25.2]	86,000 [25.2]	86,000 [25.2]	86,000 [25.2]
Net Sensible Capacity Btu [kW]	62,800 [18.4]	62,800 [18.4]	62,800 [18.4]	62,800 [18.4]
Net Latent Capacity Btu [kW]	23,200 [6.8]	23,200 [6.8]	23,200 [6.8]	23,200 [6.8]
IEER <sup>3</sup>	12.2	12.2	12.2	12.2
Net System Power kW	7.55	7.55	7.55	7.55
Heating Performance (Heat Pumps)				
High Temp. Btuh [kW] Rating	84,000 [24.6]	84,000 [24.6]	84,000 [24.6]	84,000 [24.6]
System Power KW / COP	6.84/3.3	6.84/3.3	6.84/3.3	6.84/3.3
Low Temp. Btuh [kW] Rating	48,000 [14.06]	48,000 [14.06]	48,000 [14.06]	48,000 [14.06]
System Power KW / COP	6.44/2.25	6.44/2.25	6.44/2.25	6.44/2.25
Compressor				
No./Type	1/Scroll	1/Scroll	1/Scroll	1/Scroll
Outdoor Sound Rating (dB) <sup>5</sup>	88	88	88	88
Outdoor Coil - Fin Type	Louvered	Louvered	Louvered	Louvered
Tube Type	MicroChannel	MicroChannel	MicroChannel	MicroChannel
MicroChannel Depth in. [mm]	1 [25.4]	1 [25.4]	1 [25.4]	1 [25.4]
Face Area sq. ft. [sq. m]	22.8 [2.12]	22.8 [2.12]	22.8 [2.12]	22.8 [2.12]
Rows / FPI [FPcm]	1 / 16 [6]	1 / 16 [6]	1 / 16 [6]	1 / 16 [6]
Refrigerant Control	TX Valves	TX Valves	TX Valves	TX Valves
Indoor Coil - Fin Type	Louvered	Louvered	Louvered	Louvered
Tube Type	MicroChannel	MicroChannel	MicroChannel	MicroChannel
MicroChannel Depth in. [mm]	1.26 [32]	1.26 [32]	1.26 [32]	1.26 [32]
Face Area sq. ft. [sq. m]	10.9 [1.01]	10.9 [1.01]	10.9 [1.01]	10.9 [1.01]
Rows / FPI [FPcm]	1 / 20 [8]	1 / 20 [8]	1 / 20 [8]	1 / 20 [8]
Refrigerant Control	TX Valves	TX Valves	TX Valves	TX Valves
Drain Connection No./Size in. [mm]	1/0.75 [19.05]	1/0.75 [19.05]	1/0.75 [19.05]	1/0.75 [19.05]
Outdoor Fan - Type	Propeller	Propeller	Propeller	Propeller
No. Used/Diameter in. [mm]	2/24 [609.6]	2/24 [609.6]	2/24 [609.6]	2/24 [609.6]
Drive Type/No. Speeds	Direct/1	Direct/1	Direct/1	Direct/1
CFM [L/s]	8000 [3775]	8000 [3775]	8000 [3775]	8000 [3775]
No. Motors/HP	2 at 1/2 HP	2 at 1/2 HP	2 at 1/2 HP	2 at 1/2 HP
Motor RPM	1075	1075	1075	1075
Indoor Fan - Type	FC Centrifugal	FC Centrifugal	FC Centrifugal	FC Centrifugal
No. Used/Diameter in. [mm]	1/15x15 [381x381]	1/15x15 [381x381]	1/15x15 [381x381]	1/15x15 [381x381]
Drive Type	Belt (Adjustable)	Belt (Adjustable)	Belt (Adjustable)	Belt (Adjustable)
No. Speeds	Single	Single	Single	Single
No. Motors	1	1	1	1
Motor HP	3	3	2	3
Motor RPM	1725	1725	1725	1725
Motor Frame Size	56	56	56	56
Filter - Type	Disposable	Disposable	Disposable	Disposable
Furnished	Yes	Yes	Yes	Yes
(NO.) Size Recommended in. [mm x mm x mm]	(4)2x20x20 [51x508x508]	(4)2x20x20 [51x508x508]	(4)2x20x20 [51x508x508]	(4)2x20x20 [51x508x508]
Refrigerant Charge Oz. [g]	179 [5075]	179 [5075]	179 [5075]	179 [5075]
Weights				
Net Weight lbs. [kg]	775 [352]	775 [352]	775 [352]	785 [356]
Ship Weight lbs. [kg]	814 [369]	814 [369]	814 [369]	824 [374]

### NOTES:

- Cooling Performance is rated at 95° F ambient, 80° F entering dry bulb, 67° F entering wet bulb. Gross capacity does not include the effect of fan motor heat. AHRI capacity is net and includes the effect of fan motor heat. Units are suitable for operation to ±20% of nominal cfm. Units are certified in accordance with the Unitary Air Conditioner Equipment certification program, which is based on AHRI Standard 210/240 or 360.
- EER and/or SEER are rated at AHRI conditions and in accordance with DOE test procedures.
- Integrated Part Load Value is rated in accordance with AHRI Standard 210/240 or 360. Units are rated at 80° F ambient, 80° F entering dry bulb, and 67° F entering wet bulb at AHRI rated cfm.
- Outdoor Sound Rating shown is tested in accordance with AHRI Standard 270.



## GENERAL DATA

Model -HPDZR Series	090AYC	102ACA	102ACB	102ACC
Cooling Performance <sup>1</sup>				Continued ->
Gross Cooling Capacity Btu [kW]	89,000 [26.08]	101,000 [29.59]	101,000 [29.59]	101,000 [29.59]
EER/SEER2	11/NA	11/NA	11/NA	11/NA
Nominal CFM/AHRI Rated CFM [L/s]	3000/3030 [1416/1430]	3400/3345 [1604/1579]	3400/3345 [1604/1579]	3400/3345 [1604/1579]
AHRI Net Cooling Capacity Btu [kW]	86,000 [25.2]	98,000 [28.71]	98,000 [28.71]	98,000 [28.71]
Net Sensible Capacity Btu [kW]	62,800 [18.4]	71,000 [20.8]	71,000 [20.8]	71,000 [20.8]
Net Latent Capacity Btu [kW]	23,200 [6.8]	27,000 [7.91]	27,000 [7.91]	27,000 [7.91]
IEER3	12.2	12.2	12.2	12.2
Net System Power kW	7.55	8.47	8.47	8.47
Heating Performance (Heat Pumps)				
High Temp. Btuh [kW] Rating	84,000 [24.6]	98,000 [28.71]	98,000 [28.71]	98,000 [28.71]
System Power KW / COP	6.84/3.3	7.99/3.3	7.99/3.3	7.99/3.3
Low Temp. Btuh [kW] Rating	48,000 [14.06]	60,000 [17.58]	60,000 [17.58]	60,000 [17.58]
System Power KW / COP	6.44/2.25	7.54/2.25	7.54/2.25	7.54/2.25
Compressor				
No./Type	1/Scroll	1/Scroll	1/Scroll	1/Scroll
Outdoor Sound Rating (dB)5				
	88	88	88	88
Outdoor Coil - Fin Type				
Tube Type	Louvered	Louvered	Louvered	Louvered
MicroChannel Depth in. [mm]	MicroChannel	MicroChannel	MicroChannel	MicroChannel
Face Area sq. ft. [sq. m]	1 [25.4]	1.26 [32]	1.26 [32]	1.26 [32]
Rows / FPI [FPcm]	22.8 [2.12]	22.4 [2.08]	22.4 [2.08]	22.4 [2.08]
Refrigerant Control	1 / 16 [6]	1 / 16 [6]	1 / 16 [6]	1 / 16 [6]
	TX Valves	TX Valves	TX Valves	TX Valves
Indoor Coil - Fin Type				
Tube Type	Louvered	Louvered	Louvered	Louvered
MicroChannel Depth in. [mm]	MicroChannel	MicroChannel	MicroChannel	MicroChannel
Face Area sq. ft. [sq. m]	1.26 [32]	1.26 [32]	1.26 [32]	1.26 [32]
Rows / FPI [FPcm]	10.9 [1.01]	10.9 [1.01]	10.9 [1.01]	10.9 [1.01]
Refrigerant Control	1 / 20 [8]	1 / 20 [8]	1 / 20 [8]	1 / 20 [8]
	TX Valves	TX Valves	TX Valves	TX Valves
Drain Connection No./Size in. [mm]	1/0.75 [19.05]	1/0.75 [19.05]	1/0.75 [19.05]	1/0.75 [19.05]
Outdoor Fan - Type				
No. Used/Diameter in. [mm]	Propeller	Propeller	Propeller	Propeller
Drive Type/No. Speeds	2/24 [609.6]	2/24 [609.6]	2/24 [609.6]	2/24 [609.6]
CFM [L/s]	Direct/1	Direct/1	Direct/1	Direct/1
No. Motors/HP	8000 [3775]	8000 [3775]	8000 [3775]	8000 [3775]
Motor RPM	2 at 1/2 HP	2 at 1/2 HP	2 at 1/2 HP	2 at 1/2 HP
	1075	1075	1075	1075
Indoor Fan - Type				
No. Used/Diameter in. [mm]	FC Centrifugal	FC Centrifugal	FC Centrifugal	FC Centrifugal
Drive Type	1/15x15 [381x381]	1/15x15 [381x381]	1/15x15 [381x381]	1/15x15 [381x381]
No. Speeds	Belt (Adjustable)	Belt (Adjustable)	Belt (Adjustable)	Belt (Adjustable)
No. Motors	Single	Single	Single	Single
Motor HP	1	1	1	1
Motor RPM	3	2	3	3
Motor Frame Size	1725	1725	1725	1725
	56	56	56	56
Filter - Type				
Furnished	Disposable	Disposable	Disposable	Disposable
(NO.) Size Recommended in. [mm x mm x mm]	Yes	Yes	Yes	Yes
	(4)2x20x20 [51x508x508]	(4)2x20x20 [51x508x508]	(4)2x20x20 [51x508x508]	(4)2x20x20 [51x508x508]
Refrigerant Charge Oz. [g]	179 [5075]	197 [5585]	197 [5585]	197 [5585]
Weights				
Net Weight lbs. [kg]	786 [357]	811 [368]	811 [368]	822 [373]
Ship Weight lbs. [kg]	825 [374]	850 [386]	850 [386]	861 [391]

- NOTES:**
- Cooling Performance is rated at 95° F ambient, 80° F entering dry bulb, 67° F entering wet bulb. Gross capacity does not include the effect of fan motor heat. AHRI capacity is net and includes the effect of fan motor heat. Units are suitable for operation to ±20% of nominal cfm. Units are certified in accordance with the Unitary Air Conditioner Equipment certification program, which is based on AHRI Standard 210/240 or 360.
  - EER and/or SEER are rated at AHRI conditions and in accordance with DOE test procedures.
  - Integrated Part Load Value is rated in accordance with AHRI Standard 210/240 or 360. Units are rated at 80° F ambient, 80° F entering dry bulb, and 67° F entering wet bulb at AHRI rated cfm.
  - Outdoor Sound Rating shown is tested in accordance with AHRI Standard 270.



## GENERAL DATA

Model -HPDZR Series	102ADA	102ADB	102ADC	102AYA
Cooling Performance <sup>1</sup>				Continued ->
Gross Cooling Capacity Btu [kW]	101,000 [29.59]	101,000 [29.59]	101,000 [29.59]	101,000 [29.59]
EER/SEER <sup>2</sup>	11/NA	11/NA	11/NA	11/NA
Nominal CFM/AHRI Rated CFM [L/s]	3400/3345 [1604/1579]	3400/3345 [1604/1579]	3400/3345 [1604/1579]	3400/3345 [1604/1579]
AHRI Net Cooling Capacity Btu [kW]	98,000 [28.71]	98,000 [28.71]	98,000 [28.71]	98,000 [28.71]
Net Sensible Capacity Btu [kW]	71,000 [20.8]	71,000 [20.8]	71,000 [20.8]	71,000 [20.8]
Net Latent Capacity Btu [kW]	27,000 [7.91]	27,000 [7.91]	27,000 [7.91]	27,000 [7.91]
IEER <sup>3</sup>	12.2	12.2	12.2	12.2
Net System Power kW	8.47	8.47	8.47	8.47
Heating Performance (Heat Pumps)				
High Temp. Btuh [kW] Rating	98,000 [28.71]	98,000 [28.71]	98,000 [28.71]	98,000 [28.71]
System Power KW / COP	7.99/3.3	7.99/3.3	7.99/3.3	7.99/3.3
Low Temp. Btuh [kW] Rating	60,000 [17.58]	60,000 [17.58]	60,000 [17.58]	60,000 [17.58]
System Power KW / COP	7.54/2.25	7.54/2.25	7.54/2.25	7.54/2.25
Compressor				
No./Type	1/Scroll	1/Scroll	1/Scroll	1/Scroll
Outdoor Sound Rating (dB) <sup>5</sup>	88	88	88	88
Outdoor Coil - Fin Type	Louvered	Louvered	Louvered	Louvered
Tube Type	MicroChannel	MicroChannel	MicroChannel	MicroChannel
MicroChannel Depth in. [mm]	1.26 [32]	1.26 [32]	1.26 [32]	1.26 [32]
Face Area sq. ft. [sq. m]	22.4 [2.08]	22.4 [2.08]	22.4 [2.08]	22.4 [2.08]
Rows / FPI [FPcm]	1 / 16 [6]	1 / 16 [6]	1 / 16 [6]	1 / 16 [6]
Refrigerant Control	TX Valves	TX Valves	TX Valves	TX Valves
Indoor Coil - Fin Type	Louvered	Louvered	Louvered	Louvered
Tube Type	MicroChannel	MicroChannel	MicroChannel	MicroChannel
MicroChannel Depth in. [mm]	1.26 [32]	1.26 [32]	1.26 [32]	1.26 [32]
Face Area sq. ft. [sq. m]	10.9 [1.01]	10.9 [1.01]	10.9 [1.01]	10.9 [1.01]
Rows / FPI [FPcm]	1 / 20 [8]	1 / 20 [8]	1 / 20 [8]	1 / 20 [8]
Refrigerant Control	TX Valves	TX Valves	TX Valves	TX Valves
Drain Connection No./Size in. [mm]	1/0.75 [19.05]	1/0.75 [19.05]	1/0.75 [19.05]	1/0.75 [19.05]
Outdoor Fan - Type	Propeller	Propeller	Propeller	Propeller
No. Used/Diameter in. [mm]	2/24 [609.6]	2/24 [609.6]	2/24 [609.6]	2/24 [609.6]
Drive Type/No. Speeds	Direct/1	Direct/1	Direct/1	Direct/1
CFM [L/s]	8000 [3775]	8000 [3775]	8000 [3775]	8000 [3775]
No. Motors/HP	2 at 1/2 HP	2 at 1/2 HP	2 at 1/2 HP	2 at 1/2 HP
Motor RPM	1075	1075	1075	1075
Indoor Fan - Type	FC Centrifugal	FC Centrifugal	FC Centrifugal	FC Centrifugal
No. Used/Diameter in. [mm]	1/15x15 [381x381]	1/15x15 [381x381]	1/15x15 [381x381]	1/15x15 [381x381]
Drive Type	Belt (Adjustable)	Belt (Adjustable)	Belt (Adjustable)	Belt (Adjustable)
No. Speeds	Single	Single	Single	Single
No. Motors	1	1	1	1
Motor HP	2	3	3	2
Motor RPM	1725	1725	1725	1725
Motor Frame Size	56	56	56	56
Filter - Type	Disposable	Disposable	Disposable	Disposable
Furnished	Yes	Yes	Yes	Yes
(NO.) Size Recommended in. [mm x mm x mm]	(4)2x20x20 [51x508x508]	(4)2x20x20 [51x508x508]	(4)2x20x20 [51x508x508]	(4)2x20x20 [51x508x508]
Refrigerant Charge Oz. [g]	197 [5585]	197 [5585]	197 [5585]	197 [5585]
Weights				
Net Weight lbs. [kg]	811 [368]	821 [372]	822 [373]	811 [368]
Ship Weight lbs. [kg]	850 [386]	860 [390]	861 [391]	850 [386]

### NOTES:

- Cooling Performance is rated at 95° F ambient, 80° F entering dry bulb, 67° F entering wet bulb. Gross capacity does not include the effect of fan motor heat. AHRI capacity is net and includes the effect of fan motor heat. Units are suitable for operation to ±20% of nominal cfm. Units are certified in accordance with the Unitary Air Conditioner Equipment certification program, which is based on AHRI Standard 210/240 or 360.
- EER and/or SEER are rated at AHRI conditions and in accordance with DOE test procedures.
- Integrated Part Load Value is rated in accordance with AHRI Standard 210/240 or 360. Units are rated at 80° F ambient, 80° F entering dry bulb, and 67° F entering wet bulb at AHRI rated cfm.
- Outdoor Sound Rating shown is tested in accordance with AHRI Standard 270.

## GENERAL DATA

Model -HPDZR Series	102AYB	102AYC	120ACA	120ACB
Cooling Performance <sup>1</sup>				Continued ->
Gross Cooling Capacity Btu [kW]	101,000 [29.59]	101,000 [29.59]	119,000 [34.87]	119,000 [34.87]
EER/SEER2	11/NA	11/NA	11/NA	11/NA
Nominal CFM/AHRI Rated CFM [L/s]	3400/3345 [1604/1579]	3400/3345 [1604/1579]	4000/4060 [1888/1916]	4000/4060 [1888/1916]
AHRI Net Cooling Capacity Btu [kW]	98,000 [28.71]	98,000 [28.71]	114,000 [33.4]	114,000 [33.4]
Net Sensible Capacity Btu [kW]	71,000 [20.8]	71,000 [20.8]	82,800 [24.26]	82,800 [24.26]
Net Latent Capacity Btu [kW]	27,000 [7.91]	27,000 [7.91]	31,200 [9.14]	31,200 [9.14]
IEER3	12.2	12.2	12.2	12.2
Net System Power kW	8.47	8.47	10.13	10.13
Heating Performance (Heat Pumps)				
High Temp. Btuh [kW] Rating	98,000 [28.71]	98,000 [28.71]	112,000 [32.8]	112,000 [32.8]
System Power KW / COP	7.99/3.3	7.99/3.3	9.03/3.3	9.03/3.3
Low Temp. Btuh [kW] Rating	60,000 [17.58]	60,000 [17.58]	68,000 [20.0]	68,000 [20.0]
System Power KW / COP	7.54/2.25	7.54/2.25	8.3/2.25	8.3/2.25
Compressor				
No./Type	1/Scroll	1/Scroll	1/Scroll	1/Scroll
Outdoor Sound Rating (dB)5	88	88	88	88
Outdoor Coil - Fin Type	Louvered	Louvered	Louvered	Louvered
Tube Type	MicroChannel	MicroChannel	MicroChannel	MicroChannel
MicroChannel Depth in. [mm]	1.26 [32]	1.26 [32]	1.26 [32]	1.26 [32]
Face Area sq. ft. [sq. m]	22.4 [2.08]	22.4 [2.08]	28.8 [2.68]	28.8 [2.68]
Rows / FPI [FPcm]	1 / 16 [6]	1 / 16 [6]	1 / 16 [6]	1 / 16 [6]
Refrigerant Control	TX Valves	TX Valves	TX Valves	TX Valves
Indoor Coil - Fin Type	Louvered	Louvered	Louvered	Louvered
Tube Type	MicroChannel	MicroChannel	MicroChannel	MicroChannel
MicroChannel Depth in. [mm]	1.26 [32]	1.26 [32]	1.26 [32]	1.26 [32]
Face Area sq. ft. [sq. m]	10.9 [1.01]	10.9 [1.01]	13.2 [1.23]	13.2 [1.23]
Rows / FPI [FPcm]	1 / 20 [8]	1 / 20 [8]	1 / 20 [8]	1 / 20 [8]
Refrigerant Control	TX Valves	TX Valves	TX Valves	TX Valves
Drain Connection No./Size in. [mm]	1/0.75 [19.05]	1/0.75 [19.05]	1/0.75 [19.05]	1/0.75 [19.05]
Outdoor Fan - Type	Propeller	Propeller	Propeller	Propeller
No. Used/Diameter in. [mm]	2/24 [609.6]	2/24 [609.6]	2/24 [609.6]	2/24 [609.6]
Drive Type/No. Speeds	Direct/1	Direct/1	Direct/1	Direct/1
CFM [L/s]	8000 [3775]	8000 [3775]	8000 [3775]	8000 [3775]
No. Motors/HP	2 at 1/2 HP	2 at 1/2 HP	2 at 1/2 HP	2 at 1/2 HP
Motor RPM	1075	1075	1075	1075
Indoor Fan - Type	FC Centrifugal	FC Centrifugal	FC Centrifugal	FC Centrifugal
No. Used/Diameter in. [mm]	1/15x15 [381x381]	1/15x15 [381x381]	1/15x15 [381x381]	1/15x15 [381x381]
Drive Type	Belt (Adjustable)	Belt (Adjustable)	Belt (Adjustable)	Belt (Adjustable)
No. Speeds	Single	Single	Single	Single
No. Motors	1	1	1	1
Motor HP	3	3	2	3
Motor RPM	1725	1725	1725	1725
Motor Frame Size	56	56	56	56
Filter - Type	Disposable	Disposable	Disposable	Disposable
Furnished	Yes	Yes	Yes	Yes
(NO.) Size Recommended in. [mm x mm x mm]	(4)2x20x20 [51x508x508]	(4)2x20x20 [51x508x508]	(4)2x25x20 [51x635x508]	(4)2x25x20 [51x635x508]
Refrigerant Charge Oz. [g]	197 [5585]	197 [5585]	214.4 [6078.14]	214.4 [6078.14]
Weights				
Net Weight lbs. [kg]	821 [372]	822 [373]	863 [391]	863 [391]
Ship Weight lbs. [kg]	860 [390]	861 [391]	902 [409]	902 [409]

### NOTES:

- Cooling Performance is rated at 95° F ambient, 80° F entering dry bulb, 67° F entering wet bulb. Gross capacity does not include the effect of fan motor heat. AHRI capacity is net and includes the effect of fan motor heat. Units are suitable for operation to ±20% of nominal cfm. Units are certified in accordance with the Unitary Air Conditioner Equipment certification program, which is based on AHRI Standard 210/240 or 360.
- EER and/or SEER are rated at AHRI conditions and in accordance with DOE test procedures.
- Integrated Part Load Value is rated in accordance with AHRI Standard 210/240 or 360. Units are rated at 80° F ambient, 80° F entering dry bulb, and 67° F entering wet bulb at AHRI rated cfm.
- Outdoor Sound Rating shown is tested in accordance with AHRI Standard 270.

## GENERAL DATA

Model -HPDZR Series	120ACC	120ADA	120ADB	120ADC
Cooling Performance <sup>1</sup>				Continued ->
Gross Cooling Capacity Btu [kW]	119,000 [34.87]	119,000 [34.87]	119,000 [34.87]	119,000 [34.87]
EER/SEER2	11/NA	11/NA	11/NA	11/NA
Nominal CFM/AHRI Rated CFM [L/s]	4000/4060 [1888/1916]	4000/4060 [1888/1916]	4000/4060 [1888/1916]	4000/4060 [1888/1916]
AHRI Net Cooling Capacity Btu [kW]	114,000 [33.4]	114,000 [33.4]	114,000 [33.4]	114,000 [33.4]
Net Sensible Capacity Btu [kW]	82,800 [24.26]	82,800 [24.26]	82,800 [24.26]	82,800 [24.26]
Net Latent Capacity Btu [kW]	31,200 [9.14]	31,200 [9.14]	31,200 [9.14]	31,200 [9.14]
IEER3	12.2	12.2	12.2	12.2
Net System Power kW	10.13	10.13	10.13	10.13
Heating Performance (Heat Pumps)				
High Temp. Btuh [kW] Rating	112,000 [32.8]	112,000 [32.8]	112,000 [32.8]	112,000 [32.8]
System Power KW / COP	9.03/3.3	9.03/3.3	9.03/3.3	9.03/3.3
Low Temp. Btuh [kW] Rating	68,000 [20.0]	68,000 [20.0]	68,000 [20.0]	68,000 [20.0]
System Power KW / COP	8.3/2.25	8.3/2.25	8.3/2.25	8.3/2.25
Compressor				
No./Type	1/Scroll	1/Scroll	1/Scroll	1/Scroll
Outdoor Sound Rating (dB)5	88	88	88	88
Outdoor Coil - Fin Type				
Tube Type	Louvered	Louvered	Louvered	Louvered
MicroChannel Depth in. [mm]	MicroChannel	MicroChannel	MicroChannel	MicroChannel
Face Area sq. ft. [sq. m]	1.26 [32]	1.26 [32]	1.26 [32]	1.26 [32]
Rows / FPI [FPcm]	28.8 [2.68]	28.8 [2.68]	28.8 [2.68]	28.8 [2.68]
Refrigerant Control	1 / 16 [6]	1 / 16 [6]	1 / 16 [6]	1 / 16 [6]
	TX Valves	TX Valves	TX Valves	TX Valves
Indoor Coil - Fin Type				
Tube Type	Louvered	Louvered	Louvered	Louvered
MicroChannel Depth in. [mm]	MicroChannel	MicroChannel	MicroChannel	MicroChannel
Face Area sq. ft. [sq. m]	1.26 [32]	1.26 [32]	1.26 [32]	1.26 [32]
Rows / FPI [FPcm]	13.2 [1.23]	13.2 [1.23]	13.2 [1.23]	13.2 [1.23]
Refrigerant Control	1 / 20 [8]	1 / 20 [8]	1 / 20 [8]	1 / 20 [8]
Drain Connection No./Size in. [mm]	TX Valves	TX Valves	TX Valves	TX Valves
	1/0.75 [19.05]	1/0.75 [19.05]	1/0.75 [19.05]	1/0.75 [19.05]
Outdoor Fan - Type				
No. Used/Diameter in. [mm]	Propeller	Propeller	Propeller	Propeller
Drive Type/No. Speeds	2/24 [609.6]	2/24 [609.6]	2/24 [609.6]	2/24 [609.6]
CFM [L/s]	Direct/1	Direct/1	Direct/1	Direct/1
No. Motors/HP	8000 [3775]	8000 [3775]	8000 [3775]	8000 [3775]
Motor RPM	2 at 1/2 HP	2 at 1/2 HP	2 at 1/2 HP	2 at 1/2 HP
	1075	1075	1075	1075
Indoor Fan - Type				
No. Used/Diameter in. [mm]	FC Centrifugal	FC Centrifugal	FC Centrifugal	FC Centrifugal
Drive Type	1/15x15 [381x381]	1/15x15 [381x381]	1/15x15 [381x381]	1/15x15 [381x381]
No. Speeds	Belt (Adjustable)	Belt (Adjustable)	Belt (Adjustable)	Belt (Adjustable)
No. Motors	Single	Single	Single	Single
Motor HP	1	1	1	1
Motor RPM	3	2	3	3
Motor Frame Size	1725	1725	1725	1725
	56	56	56	56
Filter - Type				
Furnished	Disposable	Disposable	Disposable	Disposable
(NO.) Size Recommended in. [mm x mm x mm]	Yes	Yes	Yes	Yes
	(4)2x25x20 [51x635x508]	(4)2x25x20 [51x635x508]	(4)2x25x20 [51x635x508]	(4)2x25x20 [51x635x508]
Refrigerant Charge Oz. [g]	214.4 [6078.14]	214.4 [6078.14]	214.4 [6078.14]	214.4 [6078.14]
Weights				
Net Weight lbs. [kg]	874 [396]	863 [391]	863 [391]	874 [396]
Ship Weight lbs. [kg]	913 [414]	902 [409]	902 [409]	913 [414]

### NOTES:

- Cooling Performance is rated at 95° F ambient, 80° F entering dry bulb, 67° F entering wet bulb. Gross capacity does not include the effect of fan motor heat. AHRI capacity is net and includes the effect of fan motor heat. Units are suitable for operation to ±20% of nominal cfm. Units are certified in accordance with the Unitary Air Conditioner Equipment certification program, which is based on AHRI Standard 210/240 or 360.
- EER and/or SEER are rated at AHRI conditions and in accordance with DOE test procedures.
- Integrated Part Load Value is rated in accordance with AHRI Standard 210/240 or 360. Units are rated at 80° F ambient, 80° F entering dry bulb, and 67° F entering wet bulb at AHRI rated cfm.
- Outdoor Sound Rating shown is tested in accordance with AHRI Standard 270.

## GENERAL DATA

Model -HPDZR Series	120AYA	120AYB	120AYC
<b>Cooling Performance<sup>1</sup></b>			
Gross Cooling Capacity Btu [kW]	119,000 [34.87]	119,000 [34.87]	119,000 [34.87]
EER/SEER2	11/NA	11/NA	11/NA
Nominal CFM/AHRI Rated CFM [L/s]	4000/4060 [1888/1916]	4000/4060 [1888/1916]	4000/4060 [1888/1916]
AHRI Net Cooling Capacity Btu [kW]	114,000 [33.4]	114,000 [33.4]	114,000 [33.4]
Net Sensible Capacity Btu [kW]	82,800 [24.26]	82,800 [24.26]	82,800 [24.26]
Net Latent Capacity Btu [kW]	31,200 [9.14]	31,200 [9.14]	31,200 [9.14]
IEER3	12.2	12.2	12.2
Net System Power kW	10.13	10.13	10.13
<b>Heating Performance (Heat Pumps)</b>			
High Temp. Btuh [kW] Rating	112,000 [32.8]	112,000 [32.8]	112,000 [32.8]
System Power KW / COP	9.03/3.3	9.03/3.3	9.03/3.3
Low Temp. Btuh [kW] Rating	68,000 [20.0]	68,000 [20.0]	68,000 [20.0]
System Power KW / COP	8.3/2.25	8.3/2.25	8.3/2.25
<b>Compressor</b>			
No./Type	1/Scroll	1/Scroll	1/Scroll
<b>Outdoor Sound Rating (dB)5</b>			
	88	88	88
<b>Outdoor Coil - Fin Type</b>			
Tube Type	MicroChannel	MicroChannel	MicroChannel
MicroChannel Depth in. [mm]	1.26 [32]	1.26 [32]	1.26 [32]
Face Area sq. ft. [sq. m]	28.8 [2.68]	28.8 [2.68]	28.8 [2.68]
Rows / FPI [FPcm]	1 / 16 [6]	1 / 16 [6]	1 / 16 [6]
Refrigerant Control	TX Valves	TX Valves	TX Valves
<b>Indoor Coil - Fin Type</b>			
Tube Type	MicroChannel	MicroChannel	MicroChannel
MicroChannel Depth in. [mm]	1.26 [32]	1.26 [32]	1.26 [32]
Face Area sq. ft. [sq. m]	13.2 [1.23]	13.2 [1.23]	13.2 [1.23]
Rows / FPI [FPcm]	1 / 20 [8]	1 / 20 [8]	1 / 20 [8]
Refrigerant Control	TX Valves	TX Valves	TX Valves
Drain Connection No./Size in. [mm]	1/0.75 [19.05]	1/0.75 [19.05]	1/0.75 [19.05]
<b>Outdoor Fan - Type</b>			
No. Used/Diameter in. [mm]	2/24 [609.6]	2/24 [609.6]	2/24 [609.6]
Drive Type/No. Speeds	Direct/1	Direct/1	Direct/1
CFM [L/s]	8000 [3775]	8000 [3775]	8000 [3775]
No. Motors/HP	2 at 1/2 HP	2 at 1/2 HP	2 at 1/2 HP
Motor RPM	1075	1075	1075
<b>Indoor Fan - Type</b>			
No. Used/Diameter in. [mm]	1/15x15 [381x381]	1/15x15 [381x381]	1/15x15 [381x381]
Drive Type	Belt (Adjustable)	Belt (Adjustable)	Belt (Adjustable)
No. Speeds	Single	Single	Single
No. Motors	1	1	1
Motor HP	2	3	3
Motor RPM	1725	1725	1725
Motor Frame Size	56	56	56
<b>Filter - Type</b>			
Furnished	Yes	Yes	Yes
(NO.) Size Recommended in. [mm x mm x mm]	(4)2x25x20 [51x635x508]	(4)2x25x20 [51x635x508]	(4)2x25x20 [51x635x508]
<b>Refrigerant Charge Oz. [g]</b>			
	214.4 [6078.14]	214.4 [6078.14]	214.4 [6078.14]
<b>Weights</b>			
Net Weight lbs. [kg]	863 [391]	873 [396]	874 [396]
Ship Weight lbs. [kg]	902 [409]	912 [414]	913 [414]

**Continued ->**

### NOTES:

- Cooling Performance is rated at 95° F ambient, 80° F entering dry bulb, 67° F entering wet bulb. Gross capacity does not include the effect of fan motor heat. AHRI capacity is net and includes the effect of fan motor heat. Units are suitable for operation to ±20% of nominal cfm. Units are certified in accordance with the Unitary Air Conditioner Equipment certification program, which is based on AHRI Standard 210/240 or 360.
- EER and/or SEER are rated at AHRI conditions and in accordance with DOE test procedures.
- Integrated Part Load Value is rated in accordance with AHRI Standard 210/240 or 360. Units are rated at 80° F ambient, 80° F entering dry bulb, and 67° F entering wet bulb at AHRI rated cfm.
- Outdoor Sound Rating shown is tested in accordance with AHRI Standard 270.

## GENERAL DATA

Model -HPDZS Series	090ACA	090ACB	090ACC	090ACF
Cooling Performance <sup>1</sup>				Continued ->
Gross Cooling Capacity Btu [kW]	89,000 [26.08]	89,000 [26.08]	89,000 [26.08]	89,000 [26.08]
EER/SEER2	11/NA	11/NA	11/NA	11/NA
Nominal CFM/AHRI Rated CFM [L/s]	3000/3030 [1416/1430]	3000/3030 [1416/1430]	3000/3030 [1416/1430]	3000/3030 [1416/1430]
AHRI Net Cooling Capacity Btu [kW]	86,000 [25.2]	86,000 [25.2]	86,000 [25.2]	86,000 [25.2]
Net Sensible Capacity Btu [kW]	62,800 [18.4]	62,800 [18.4]	62,800 [18.4]	62,800 [18.4]
Net Latent Capacity Btu [kW]	23,200 [6.8]	23,200 [6.8]	23,200 [6.8]	23,200 [6.8]
IEER3	12.2	12.2	12.2	12.2
Net System Power kW	7.55	7.55	7.55	7.55
Heating Performance (Heat Pumps)				
High Temp. Btuh [kW] Rating	84,000 [24.6]	84,000 [24.6]	84,000 [24.6]	84,000 [24.6]
System Power KW / COP	6.84/3.3	6.84/3.3	6.84/3.3	6.84/3.3
Low Temp. Btuh [kW] Rating	48,000 [14.06]	48,000 [14.06]	48,000 [14.06]	48,000 [14.06]
System Power KW / COP	6.44/2.25	6.44/2.25	6.44/2.25	6.44/2.25
Compressor				
No./Type	1/Scroll	1/Scroll	1/Scroll	1/Scroll
Outdoor Sound Rating (dB)5	88	88	88	88
Outdoor Coil - Fin Type	Louvered	Louvered	Louvered	Louvered
Tube Type	MicroChannel	MicroChannel	MicroChannel	MicroChannel
MicroChannel Depth in. [mm]	1 [25.4]	1 [25.4]	1 [25.4]	1 [25.4]
Face Area sq. ft. [sq. m]	22.8 [2.12]	22.8 [2.12]	22.8 [2.12]	22.8 [2.12]
Rows / FPI [FPcm]	1 / 16 [6]	1 / 16 [6]	1 / 16 [6]	1 / 16 [6]
Refrigerant Control	TX Valves	TX Valves	TX Valves	TX Valves
Indoor Coil - Fin Type	Louvered	Louvered	Louvered	Louvered
Tube Type	MicroChannel	MicroChannel	MicroChannel	MicroChannel
MicroChannel Depth in. [mm]	1.26 [32]	1.26 [32]	1.26 [32]	1.26 [32]
Face Area sq. ft. [sq. m]	10.9 [1.01]	10.9 [1.01]	10.9 [1.01]	10.9 [1.01]
Rows / FPI [FPcm]	1 / 20 [8]	1 / 20 [8]	1 / 20 [8]	1 / 20 [8]
Refrigerant Control	TX Valves	TX Valves	TX Valves	TX Valves
Drain Connection No./Size in. [mm]	1/0.75 [19.05]	1/0.75 [19.05]	1/0.75 [19.05]	1/0.75 [19.05]
Outdoor Fan - Type	Propeller	Propeller	Propeller	Propeller
No. Used/Diameter in. [mm]	2/24 [609.6]	2/24 [609.6]	2/24 [609.6]	2/24 [609.6]
Drive Type/No. Speeds	Direct/1	Direct/1	Direct/1	Direct/1
CFM [L/s]	8000 [3775]	8000 [3775]	8000 [3775]	8000 [3775]
No. Motors/HP	2 at 1/2 HP	2 at 1/2 HP	2 at 1/2 HP	2 at 1/2 HP
Motor RPM	1075	1075	1075	1075
Indoor Fan - Type	FC Centrifugal	FC Centrifugal	FC Centrifugal	FC Centrifugal
No. Used/Diameter in. [mm]	1/15x15 [381x381]	1/15x15 [381x381]	1/15x15 [381x381]	1/15x15 [381x381]
Drive Type	Belt (Adjustable)	Belt (Adjustable)	Belt (Adjustable)	Belt (Adjustable)
No. Speeds	Single	Single	Single	Single
No. Motors	1	1	1	1
Motor HP	2	3	3	2
Motor RPM	1725	1725	1725	1725
Motor Frame Size	56	56	56	56
Filter - Type	Disposable	Disposable	Disposable	Disposable
Furnished	Yes	Yes	Yes	Yes
(NO.) Size Recommended in. [mm x mm x mm]	(4)2x20x20 [51x508x508]	(4)2x20x20 [51x508x508]	(4)2x20x20 [51x508x508]	(4)2x20x20 [51x508x508]
Refrigerant Charge Oz. [g]	179 [5075]	179 [5075]	179 [5075]	179 [5075]
Weights				
Net Weight lbs. [kg]	775 [352]	785 [356]	786 [357]	775 [352]
Ship Weight lbs. [kg]	814 [369]	824 [374]	825 [374]	814 [369]

### NOTES:

- Cooling Performance is rated at 95° F ambient, 80° F entering dry bulb, 67° F entering wet bulb. Gross capacity does not include the effect of fan motor heat. AHRI capacity is net and includes the effect of fan motor heat. Units are suitable for operation to ±20% of nominal cfm. Units are certified in accordance with the Unitary Air Conditioner Equipment certification program, which is based on AHRI Standard 210/240 or 360.
- EER and/or SEER are rated at AHRI conditions and in accordance with DOE test procedures.
- Integrated Part Load Value is rated in accordance with AHRI Standard 210/240 or 360. Units are rated at 80° F ambient, 80° F entering dry bulb, and 67° F entering wet bulb at AHRI rated cfm.
- Outdoor Sound Rating shown is tested in accordance with AHRI Standard 270.

## GENERAL DATA

Model -HPDZS Series	090ACG	090ACH	090ADA	090ADB
Cooling Performance <sup>1</sup>				Continued ->
Gross Cooling Capacity Btu [kW]	89,000 [26.08]	89,000 [26.08]	89,000 [26.08]	89,000 [26.08]
EER/SEER2	11/NA	11/NA	11/NA	11/NA
Nominal CFM/AHRI Rated CFM [L/s]	3000/3030 [1416/1430]	3000/3030 [1416/1430]	3000/3030 [1416/1430]	3000/3030 [1416/1430]
AHRI Net Cooling Capacity Btu [kW]	86,000 [25.2]	86,000 [25.2]	86,000 [25.2]	86,000 [25.2]
Net Sensible Capacity Btu [kW]	62,800 [18.4]	62,800 [18.4]	62,800 [18.4]	62,800 [18.4]
Net Latent Capacity Btu [kW]	23,200 [6.8]	23,200 [6.8]	23,200 [6.8]	23,200 [6.8]
IEER3	12.2	12.2	12.2	12.2
Net System Power kW	7.55	7.55	7.55	7.55
Heating Performance (Heat Pumps)				
High Temp. Btuh [kW] Rating	84,000 [24.6]	84,000 [24.6]	84,000 [24.6]	84,000 [24.6]
System Power KW / COP	6.84/3.3	6.84/3.3	6.84/3.3	6.84/3.3
Low Temp. Btuh [kW] Rating	48,000 [14.06]	48,000 [14.06]	48,000 [14.06]	48,000 [14.06]
System Power KW / COP	6.44/2.25	6.44/2.25	6.44/2.25	6.44/2.25
Compressor				
No./Type	1/Scroll	1/Scroll	1/Scroll	1/Scroll
Outdoor Sound Rating (dB)5	88	88	88	88
Outdoor Coil - Fin Type	Louvered	Louvered	Louvered	Louvered
Tube Type	MicroChannel	MicroChannel	MicroChannel	MicroChannel
MicroChannel Depth in. [mm]	1 [25.4]	1 [25.4]	1 [25.4]	1 [25.4]
Face Area sq. ft. [sq. m]	22.8 [2.12]	22.8 [2.12]	22.8 [2.12]	22.8 [2.12]
Rows / FPI [FPcm]	1 / 16 [6]	1 / 16 [6]	1 / 16 [6]	1 / 16 [6]
Refrigerant Control	TX Valves	TX Valves	TX Valves	TX Valves
Indoor Coil - Fin Type	Louvered	Louvered	Louvered	Louvered
Tube Type	MicroChannel	MicroChannel	MicroChannel	MicroChannel
MicroChannel Depth in. [mm]	1.26 [32]	1.26 [32]	1.26 [32]	1.26 [32]
Face Area sq. ft. [sq. m]	10.9 [1.01]	10.9 [1.01]	10.9 [1.01]	10.9 [1.01]
Rows / FPI [FPcm]	1 / 20 [8]	1 / 20 [8]	1 / 20 [8]	1 / 20 [8]
Refrigerant Control	TX Valves	TX Valves	TX Valves	TX Valves
Drain Connection No./Size in. [mm]	1/0.75 [19.05]	1/0.75 [19.05]	1/0.75 [19.05]	1/0.75 [19.05]
Outdoor Fan - Type	Propeller	Propeller	Propeller	Propeller
No. Used/Diameter in. [mm]	2/24 [609.6]	2/24 [609.6]	2/24 [609.6]	2/24 [609.6]
Drive Type/No. Speeds	Direct/1	Direct/1	Direct/1	Direct/1
CFM [L/s]	8000 [3775]	8000 [3775]	8000 [3775]	8000 [3775]
No. Motors/HP	2 at 1/2 HP	2 at 1/2 HP	2 at 1/2 HP	2 at 1/2 HP
Motor RPM	1075	1075	1075	1075
Indoor Fan - Type	FC Centrifugal	FC Centrifugal	FC Centrifugal	FC Centrifugal
No. Used/Diameter in. [mm]	1/15x15 [381x381]	1/15x15 [381x381]	1/15x15 [381x381]	1/15x15 [381x381]
Drive Type	Belt (Adjustable)	Belt (Adjustable)	Belt (Adjustable)	Belt (Adjustable)
No. Speeds	Single	Single	Single	Single
No. Motors	1	1	1	1
Motor HP	3	3	2	3
Motor RPM	1725	1725	1725	1725
Motor Frame Size	56	56	56	56
Filter - Type	Disposable	Disposable	Disposable	Disposable
Furnished	Yes	Yes	Yes	Yes
(NO.) Size Recommended in. [mm x mm x mm]	(4)2x20x20 [51x508x508]	(4)2x20x20 [51x508x508]	(4)2x20x20 [51x508x508]	(4)2x20x20 [51x508x508]
Refrigerant Charge Oz. [g]	179 [5075]	179 [5075]	179 [5075]	179 [5075]
Weights				
Net Weight lbs. [kg]	785 [356]	786 [357]	775 [352]	785 [356]
Ship Weight lbs. [kg]	824 [374]	825 [374]	814 [369]	824 [374]

### NOTES:

- Cooling Performance is rated at 95° F ambient, 80° F entering dry bulb, 67° F entering wet bulb. Gross capacity does not include the effect of fan motor heat. AHRI capacity is net and includes the effect of fan motor heat. Units are suitable for operation to ±20% of nominal cfm. Units are certified in accordance with the Unitary Air Conditioner Equipment certification program, which is based on AHRI Standard 210/240 or 360.
- EER and/or SEER are rated at AHRI conditions and in accordance with DOE test procedures.
- Integrated Part Load Value is rated in accordance with AHRI Standard 210/240 or 360. Units are rated at 80° F ambient, 80° F entering dry bulb, and 67° F entering wet bulb at AHRI rated cfm.
- Outdoor Sound Rating shown is tested in accordance with AHRI Standard 270.



## GENERAL DATA

Model -HPDZS Series	090ADC	090ADF	090ADG	090ADH
Cooling Performance <sup>1</sup>				Continued ->
Gross Cooling Capacity Btu [kW]	89,000 [26.08]	89,000 [26.08]	89,000 [26.08]	89,000 [26.08]
EER/SEER2	11/NA	11/NA	11/NA	11/NA
Nominal CFM/AHRI Rated CFM [L/s]	3000/3030 [1416/1430]	3000/3030 [1416/1430]	3000/3030 [1416/1430]	3000/3030 [1416/1430]
AHRI Net Cooling Capacity Btu [kW]	86,000 [25.2]	86,000 [25.2]	86,000 [25.2]	86,000 [25.2]
Net Sensible Capacity Btu [kW]	62,800 [18.4]	62,800 [18.4]	62,800 [18.4]	62,800 [18.4]
Net Latent Capacity Btu [kW]	23,200 [6.8]	23,200 [6.8]	23,200 [6.8]	23,200 [6.8]
IEER3	12.2	12.2	12.2	12.2
Net System Power kW	7.55	7.55	7.55	7.55
Heating Performance (Heat Pumps)				
High Temp. Btuh [kW] Rating	84,000 [24.6]	84,000 [24.6]	84,000 [24.6]	84,000 [24.6]
System Power KW / COP	6.84/3.3	6.84/3.3	6.84/3.3	6.84/3.3
Low Temp. Btuh [kW] Rating	48,000 [14.06]	48,000 [14.06]	48,000 [14.06]	48,000 [14.06]
System Power KW / COP	6.44/2.25	6.44/2.25	6.44/2.25	6.44/2.25
Compressor				
No./Type	1/Scroll	1/Scroll	1/Scroll	1/Scroll
Outdoor Sound Rating (dB)5	88	88	88	88
Outdoor Coil - Fin Type				
Tube Type	Louvered	Louvered	Louvered	Louvered
MicroChannel Depth in. [mm]	MicroChannel	MicroChannel	MicroChannel	MicroChannel
Face Area sq. ft. [sq. m]	1 [25.4]	1 [25.4]	1 [25.4]	1 [25.4]
Rows / FPI [FPcm]	22.8 [2.12]	22.8 [2.12]	22.8 [2.12]	22.8 [2.12]
Refrigerant Control	1 / 16 [6]	1 / 16 [6]	1 / 16 [6]	1 / 16 [6]
Refrigerant Control	TX Valves	TX Valves	TX Valves	TX Valves
Indoor Coil - Fin Type				
Tube Type	Louvered	Louvered	Louvered	Louvered
MicroChannel Depth in. [mm]	MicroChannel	MicroChannel	MicroChannel	MicroChannel
Face Area sq. ft. [sq. m]	1.26 [32]	1.26 [32]	1.26 [32]	1.26 [32]
Rows / FPI [FPcm]	10.9 [1.01]	10.9 [1.01]	10.9 [1.01]	10.9 [1.01]
Refrigerant Control	1 / 20 [8]	1 / 20 [8]	1 / 20 [8]	1 / 20 [8]
Refrigerant Control	TX Valves	TX Valves	TX Valves	TX Valves
Drain Connection No./Size in. [mm]	1/0.75 [19.05]	1/0.75 [19.05]	1/0.75 [19.05]	1/0.75 [19.05]
Outdoor Fan - Type				
No. Used/Diameter in. [mm]	Propeller	Propeller	Propeller	Propeller
Drive Type/No. Speeds	2/24 [609.6]	2/24 [609.6]	2/24 [609.6]	2/24 [609.6]
CFM [L/s]	Direct/1	Direct/1	Direct/1	Direct/1
No. Motors/HP	8000 [3775]	8000 [3775]	8000 [3775]	8000 [3775]
Motor RPM	2 at 1/2 HP	2 at 1/2 HP	2 at 1/2 HP	2 at 1/2 HP
Motor RPM	1075	1075	1075	1075
Indoor Fan - Type				
No. Used/Diameter in. [mm]	FC Centrifugal	FC Centrifugal	FC Centrifugal	FC Centrifugal
Drive Type	1/15x15 [381x381]	1/15x15 [381x381]	1/15x15 [381x381]	1/15x15 [381x381]
No. Speeds	Belt (Adjustable)	Belt (Adjustable)	Belt (Adjustable)	Belt (Adjustable)
No. Motors	Single	Single	Single	Single
Motor HP	1	1	1	1
Motor RPM	3	2	3	3
Motor RPM	1725	1725	1725	1725
Motor Frame Size	56	56	56	56
Filter - Type				
Furnished	Disposable	Disposable	Disposable	Disposable
(NO.) Size Recommended in. [mm x mm x mm]	Yes	Yes	Yes	Yes
Refrigerant Charge Oz. [g]	(4)2x20x20 [51x508x508]	(4)2x20x20 [51x508x508]	(4)2x20x20 [51x508x508]	(4)2x20x20 [51x508x508]
Weights				
Net Weight lbs. [kg]	179 [5075]	179 [5075]	179 [5075]	179 [5075]
Ship Weight lbs. [kg]	786 [357]	775 [352]	785 [356]	786 [357]
	825 [374]	814 [369]	824 [374]	825 [374]

### NOTES:

- Cooling Performance is rated at 95° F ambient, 80° F entering dry bulb, 67° F entering wet bulb. Gross capacity does not include the effect of fan motor heat. AHRI capacity is net and includes the effect of fan motor heat. Units are suitable for operation to ±20% of nominal cfm. Units are certified in accordance with the Unitary Air Conditioner Equipment certification program, which is based on AHRI Standard 210/240 or 360.
- EER and/or SEER are rated at AHRI conditions and in accordance with DOE test procedures.
- Integrated Part Load Value is rated in accordance with AHRI Standard 210/240 or 360. Units are rated at 80° F ambient, 80° F entering dry bulb, and 67° F entering wet bulb at AHRI rated cfm.
- Outdoor Sound Rating shown is tested in accordance with AHRI Standard 270.

## GENERAL DATA

Model -HPDZS Series	090AYA	090AYB	090AYC	090AYF
Cooling Performance <sup>1</sup>				Continued ->
Gross Cooling Capacity Btu [kW]	89,000 [26.08]	89,000 [26.08]	89,000 [26.08]	89,000 [26.08]
EER/SEER2	11/NA	11/NA	11/NA	11/NA
Nominal CFM/AHRI Rated CFM [L/s]	3000/3030 [1416/1430]	3000/3030 [1416/1430]	3000/3030 [1416/1430]	3000/3030 [1416/1430]
AHRI Net Cooling Capacity Btu [kW]	86,000 [25.2]	86,000 [25.2]	86,000 [25.2]	86,000 [25.2]
Net Sensible Capacity Btu [kW]	62,800 [18.4]	62,800 [18.4]	62,800 [18.4]	62,800 [18.4]
Net Latent Capacity Btu [kW]	23,200 [6.8]	23,200 [6.8]	23,200 [6.8]	23,200 [6.8]
IEER3	12.2	12.2	12.2	12.2
Net System Power kW	7.55	7.55	7.55	7.55
Heating Performance (Heat Pumps)				
High Temp. Btuh [kW] Rating	84,000 [24.6]	84,000 [24.6]	84,000 [24.6]	84,000 [24.6]
System Power KW / COP	6.84/3.3	6.84/3.3	6.84/3.3	6.84/3.3
Low Temp. Btuh [kW] Rating	48,000 [14.06]	48,000 [14.06]	48,000 [14.06]	48,000 [14.06]
System Power KW / COP	6.44/2.25	6.44/2.25	6.44/2.25	6.44/2.25
Compressor				
No./Type	1/Scroll	1/Scroll	1/Scroll	1/Scroll
Outdoor Sound Rating (dB)5	88	88	88	88
Outdoor Coil - Fin Type				
Tube Type	Louvered	Louvered	Louvered	Louvered
MicroChannel Depth in. [mm]	1 [25.4]	1 [25.4]	1 [25.4]	1 [25.4]
Face Area sq. ft. [sq. m]	22.8 [2.12]	22.8 [2.12]	22.8 [2.12]	22.8 [2.12]
Rows / FPI [FPcm]	1 / 16 [6]	1 / 16 [6]	1 / 16 [6]	1 / 16 [6]
Refrigerant Control	TX Valves	TX Valves	TX Valves	TX Valves
Indoor Coil - Fin Type				
Tube Type	Louvered	Louvered	Louvered	Louvered
MicroChannel Depth in. [mm]	1.26 [32]	1.26 [32]	1.26 [32]	1.26 [32]
Face Area sq. ft. [sq. m]	10.9 [1.01]	10.9 [1.01]	10.9 [1.01]	10.9 [1.01]
Rows / FPI [FPcm]	1 / 20 [8]	1 / 20 [8]	1 / 20 [8]	1 / 20 [8]
Refrigerant Control	TX Valves	TX Valves	TX Valves	TX Valves
Drain Connection No./Size in. [mm]	1/0.75 [19.05]	1/0.75 [19.05]	1/0.75 [19.05]	1/0.75 [19.05]
Outdoor Fan - Type				
No. Used/Diameter in. [mm]	2/24 [609.6]	2/24 [609.6]	2/24 [609.6]	2/24 [609.6]
Drive Type/No. Speeds	Direct/1	Direct/1	Direct/1	Direct/1
CFM [L/s]	8000 [3775]	8000 [3775]	8000 [3775]	8000 [3775]
No. Motors/HP	2 at 1/2 HP	2 at 1/2 HP	2 at 1/2 HP	2 at 1/2 HP
Motor RPM	1075	1075	1075	1075
Indoor Fan - Type				
No. Used/Diameter in. [mm]	1/15x15 [381x381]	1/15x15 [381x381]	1/15x15 [381x381]	1/15x15 [381x381]
Drive Type	Belt (Adjustable)	Belt (Adjustable)	Belt (Adjustable)	Belt (Adjustable)
No. Speeds	Single	Single	Single	Single
No. Motors	1	1	1	1
Motor HP	2	3	3	2
Motor RPM	1725	1725	1725	1725
Motor Frame Size	56	56	56	56
Filter - Type				
Furnished	Yes	Yes	Yes	Yes
(NO.) Size Recommended in. [mm x mm x mm]	(4)2x20x20 [51x508x508]	(4)2x20x20 [51x508x508]	(4)2x20x20 [51x508x508]	(4)2x20x20 [51x508x508]
Refrigerant Charge Oz. [g]	179 [5075]	179 [5075]	179 [5075]	179 [5075]
Weights				
Net Weight lbs. [kg]	775 [352]	785 [356]	786 [357]	775 [352]
Ship Weight lbs. [kg]	814 [369]	824 [374]	825 [374]	814 [369]

### NOTES:

- Cooling Performance is rated at 95° F ambient, 80° F entering dry bulb, 67° F entering wet bulb. Gross capacity does not include the effect of fan motor heat. AHRI capacity is net and includes the effect of fan motor heat. Units are suitable for operation to ±20% of nominal cfm. Units are certified in accordance with the Unitary Air Conditioner Equipment certification program, which is based on AHRI Standard 210/240 or 360.
- EER and/or SEER are rated at AHRI conditions and in accordance with DOE test procedures.
- Integrated Part Load Value is rated in accordance with AHRI Standard 210/240 or 360. Units are rated at 80° F ambient, 80° F entering dry bulb, and 67° F entering wet bulb at AHRI rated cfm.
- Outdoor Sound Rating shown is tested in accordance with AHRI Standard 270.



## GENERAL DATA

Model -HPDZS Series	090AYG	090AYH	102ACA	102ACB
Cooling Performance <sup>1</sup>				Continued ->
Gross Cooling Capacity Btu [kW]	89,000 [26.08]	89,000 [26.08]	101,000 [29.59]	101,000 [29.59]
EER/SEER2	11/NA	11/NA	11/NA	11/NA
Nominal CFM/AHRI Rated CFM [L/s]	3000/3030 [1416/1430]	3000/3030 [1416/1430]	3400/3345 [1604/1579]	3400/3345 [1604/1579]
AHRI Net Cooling Capacity Btu [kW]	86,000 [25.2]	86,000 [25.2]	98,000 [28.71]	98,000 [28.71]
Net Sensible Capacity Btu [kW]	62,800 [18.4]	62,800 [18.4]	71,000 [20.8]	71,000 [20.8]
Net Latent Capacity Btu [kW]	23,200 [6.8]	23,200 [6.8]	27,000 [7.91]	27,000 [7.91]
IEER3	12.2	12.2	12.2	12.2
Net System Power kW	7.55	7.55	8.47	8.47
Heating Performance (Heat Pumps)				
High Temp. Btuh [kW] Rating	84,000 [24.6]	84,000 [24.6]	98,000 [28.71]	98,000 [28.71]
System Power KW / COP	6.84/3.3	6.84/3.3	7.99/3.3	7.99/3.3
Low Temp. Btuh [kW] Rating	48,000 [14.06]	48,000 [14.06]	60,000 [17.58]	60,000 [17.58]
System Power KW / COP	6.44/2.25	6.44/2.25	7.54/2.25	7.54/2.25
Compressor				
No./Type	1/Scroll	1/Scroll	1/Scroll	1/Scroll
Outdoor Sound Rating (dB)5	88	88	88	88
Outdoor Coil - Fin Type	Louvered	Louvered	Louvered	Louvered
Tube Type	MicroChannel	MicroChannel	MicroChannel	MicroChannel
MicroChannel Depth in. [mm]	1 [25.4]	1 [25.4]	1.26 [32]	1.26 [32]
Face Area sq. ft. [sq. m]	22.8 [2.12]	22.8 [2.12]	22.4 [2.08]	22.4 [2.08]
Rows / FPI [FPcm]	1 / 16 [6]	1 / 16 [6]	1 / 16 [6]	1 / 16 [6]
Refrigerant Control	TX Valves	TX Valves	TX Valves	TX Valves
Indoor Coil - Fin Type	Louvered	Louvered	Louvered	Louvered
Tube Type	MicroChannel	MicroChannel	MicroChannel	MicroChannel
MicroChannel Depth in. [mm]	1.26 [32]	1.26 [32]	1.26 [32]	1.26 [32]
Face Area sq. ft. [sq. m]	10.9 [1.01]	10.9 [1.01]	10.9 [1.01]	10.9 [1.01]
Rows / FPI [FPcm]	1 / 20 [8]	1 / 20 [8]	1 / 20 [8]	1 / 20 [8]
Refrigerant Control	TX Valves	TX Valves	TX Valves	TX Valves
Drain Connection No./Size in. [mm]	1/0.75 [19.05]	1/0.75 [19.05]	1/0.75 [19.05]	1/0.75 [19.05]
Outdoor Fan - Type	Propeller	Propeller	Propeller	Propeller
No. Used/Diameter in. [mm]	2/24 [609.6]	2/24 [609.6]	2/24 [609.6]	2/24 [609.6]
Drive Type/No. Speeds	Direct/1	Direct/1	Direct/1	Direct/1
CFM [L/s]	8000 [3775]	8000 [3775]	8000 [3775]	8000 [3775]
No. Motors/HP	2 at 1/2 HP	2 at 1/2 HP	2 at 1/2 HP	2 at 1/2 HP
Motor RPM	1075	1075	1075	1075
Indoor Fan - Type	FC Centrifugal	FC Centrifugal	FC Centrifugal	FC Centrifugal
No. Used/Diameter in. [mm]	1/15x15 [381x381]	1/15x15 [381x381]	1/15x15 [381x381]	1/15x15 [381x381]
Drive Type	Belt (Adjustable)	Belt (Adjustable)	Belt (Adjustable)	Belt (Adjustable)
No. Speeds	Single	Single	Single	Single
No. Motors	1	1	1	1
Motor HP	3	3	2	3
Motor RPM	1725	1725	1725	1725
Motor Frame Size	56	56	56	56
Filter - Type	Disposable	Disposable	Disposable	Disposable
Furnished	Yes	Yes	Yes	Yes
(NO.) Size Recommended in. [mm x mm x mm]	(4)2x20x20 [51x508x508]	(4)2x20x20 [51x508x508]	(4)2x20x20 [51x508x508]	(4)2x20x20 [51x508x508]
Refrigerant Charge Oz. [g]	179 [5075]	179 [5075]	197 [5585]	197 [5585]
Weights				
Net Weight lbs. [kg]	785 [356]	786 [357]	811 [368]	821 [372]
Ship Weight lbs. [kg]	824 [374]	825 [374]	850 [386]	860 [390]

### NOTES:

- Cooling Performance is rated at 95° F ambient, 80° F entering dry bulb, 67° F entering wet bulb. Gross capacity does not include the effect of fan motor heat. AHRI capacity is net and includes the effect of fan motor heat. Units are suitable for operation to ±20% of nominal cfm. Units are certified in accordance with the Unitary Air Conditioner Equipment certification program, which is based on AHRI Standard 210/240 or 360.
- EER and/or SEER are rated at AHRI conditions and in accordance with DOE test procedures.
- Integrated Part Load Value is rated in accordance with AHRI Standard 210/240 or 360. Units are rated at 80° F ambient, 80° F entering dry bulb, and 67° F entering wet bulb at AHRI rated cfm.
- Outdoor Sound Rating shown is tested in accordance with AHRI Standard 270.

## GENERAL DATA

Model -HPDZS Series	102ACC	102ACF	102ACG	102ACH
Cooling Performance <sup>1</sup>				Continued ->
Gross Cooling Capacity Btu [kW]	101,000 [29.59]	101,000 [29.59]	101,000 [29.59]	101,000 [29.59]
EER/SEER2	11/NA	11/NA	11/NA	11/NA
Nominal CFM/AHRI Rated CFM [L/s]	3400/3345 [1604/1579]	3400/3345 [1604/1579]	3400/3345 [1604/1579]	3400/3345 [1604/1579]
AHRI Net Cooling Capacity Btu [kW]	98,000 [28.71]	98,000 [28.71]	98,000 [28.71]	98,000 [28.71]
Net Sensible Capacity Btu [kW]	71,000 [20.8]	71,000 [20.8]	71,000 [20.8]	71,000 [20.8]
Net Latent Capacity Btu [kW]	27,000 [7.91]	27,000 [7.91]	27,000 [7.91]	27,000 [7.91]
IEER3	12.2	12.2	12.2	12.2
Net System Power kW	8.47	8.47	8.47	8.47
Heating Performance (Heat Pumps)				
High Temp. Btuh [kW] Rating	98,000 [28.71]	98,000 [28.71]	98,000 [28.71]	98,000 [28.71]
System Power KW / COP	7.99/3.3	7.99/3.3	7.99/3.3	7.99/3.3
Low Temp. Btuh [kW] Rating	60,000 [17.58]	60,000 [17.58]	60,000 [17.58]	60,000 [17.58]
System Power KW / COP	7.54/2.25	7.54/2.25	7.54/2.25	7.54/2.25
Compressor				
No./Type	1/Scroll	1/Scroll	1/Scroll	1/Scroll
Outdoor Sound Rating (dB)5	88	88	88	88
Outdoor Coil - Fin Type				
Tube Type	Louvered	Louvered	Louvered	Louvered
MicroChannel Depth in. [mm]	MicroChannel	MicroChannel	MicroChannel	MicroChannel
Face Area sq. ft. [sq. m]	1.26 [32]	1.26 [32]	1.26 [32]	1.26 [32]
Rows / FPI [FPcm]	22.4 [2.08]	22.4 [2.08]	22.4 [2.08]	22.4 [2.08]
Refrigerant Control	1 / 16 [6]	1 / 16 [6]	1 / 16 [6]	1 / 16 [6]
Indoor Coil - Fin Type				
Tube Type	TX Valves	TX Valves	TX Valves	TX Valves
MicroChannel Depth in. [mm]	Louvered	Louvered	Louvered	Louvered
Face Area sq. ft. [sq. m]	MicroChannel	MicroChannel	MicroChannel	MicroChannel
Rows / FPI [FPcm]	1.26 [32]	1.26 [32]	1.26 [32]	1.26 [32]
Refrigerant Control	10.9 [1.01]	10.9 [1.01]	10.9 [1.01]	10.9 [1.01]
Drain Connection No./Size in. [mm]	1 / 20 [8]	1 / 20 [8]	1 / 20 [8]	1 / 20 [8]
Outdoor Fan - Type				
No. Used/Diameter in. [mm]	Propeller	Propeller	Propeller	Propeller
Drive Type/No. Speeds	2/24 [609.6]	2/24 [609.6]	2/24 [609.6]	2/24 [609.6]
CFM [L/s]	Direct/1	Direct/1	Direct/1	Direct/1
No. Motors/HP	8000 [3775]	8000 [3775]	8000 [3775]	8000 [3775]
Motor RPM	2 at 1/2 HP	2 at 1/2 HP	2 at 1/2 HP	2 at 1/2 HP
Indoor Fan - Type				
No. Used/Diameter in. [mm]	1075	1075	1075	1075
Drive Type	FC Centrifugal	FC Centrifugal	FC Centrifugal	FC Centrifugal
No. Speeds	1/15x15 [381x381]	1/15x15 [381x381]	1/15x15 [381x381]	1/15x15 [381x381]
No. Motors	Belt (Adjustable)	Belt (Adjustable)	Belt (Adjustable)	Belt (Adjustable)
Motor HP	Single	Single	Single	Single
Motor RPM	1	1	1	1
Motor Frame Size	3	2	3	3
Filter - Type				
Furnished	1725	1725	1725	1725
(NO.) Size Recommended in. [mm x mm x mm]	56	56	56	56
Refrigerant Charge Oz. [g]				
	Disposible	Disposible	Disposible	Disposible
	Yes	Yes	Yes	Yes
	(4)2x20x20 [51x508x508]	(4)2x20x20 [51x508x508]	(4)2x20x20 [51x508x508]	(4)2x20x20 [51x508x508]
Weights				
Net Weight lbs. [kg]	197 [5585]	197 [5585]	197 [5585]	197 [5585]
Ship Weight lbs. [kg]	822 [373]	811 [368]	821 [372]	822 [373]
	861 [391]	850 [386]	860 [390]	861 [391]

### NOTES:

- Cooling Performance is rated at 95° F ambient, 80° F entering dry bulb, 67° F entering wet bulb. Gross capacity does not include the effect of fan motor heat. AHRI capacity is net and includes the effect of fan motor heat. Units are suitable for operation to ±20% of nominal cfm. Units are certified in accordance with the Unitary Air Conditioner Equipment certification program, which is based on AHRI Standard 210/240 or 360.
- EER and/or SEER are rated at AHRI conditions and in accordance with DOE test procedures.
- Integrated Part Load Value is rated in accordance with AHRI Standard 210/240 or 360. Units are rated at 80° F ambient, 80° F entering dry bulb, and 67° F entering wet bulb at AHRI rated cfm.
- Outdoor Sound Rating shown is tested in accordance with AHRI Standard 270.

## GENERAL DATA

Model -HPDZS Series	102ADA	102ADB	102ADC	102ADF
Cooling Performance <sup>1</sup>				Continued ->
Gross Cooling Capacity Btu [kW]	101,000 [29.59]	101,000 [29.59]	101,000 [29.59]	101,000 [29.59]
EER/SEER2	11/NA	11/NA	11/NA	11/NA
Nominal CFM/AHRI Rated CFM [L/s]	3400/3345 [1604/1579]	3400/3345 [1604/1579]	3400/3345 [1604/1579]	3400/3345 [1604/1579]
AHRI Net Cooling Capacity Btu [kW]	98,000 [28.71]	98,000 [28.71]	98,000 [28.71]	98,000 [28.71]
Net Sensible Capacity Btu [kW]	71,000 [20.8]	71,000 [20.8]	71,000 [20.8]	71,000 [20.8]
Net Latent Capacity Btu [kW]	27,000 [7.91]	27,000 [7.91]	27,000 [7.91]	27,000 [7.91]
IEER3	12.2	12.2	12.2	12.2
Net System Power kW	8.47	8.47	8.47	8.47
Heating Performance (Heat Pumps)				
High Temp. Btuh [kW] Rating	98,000 [28.71]	98,000 [28.71]	98,000 [28.71]	98,000 [28.71]
System Power KW / COP	7.99/3.3	7.99/3.3	7.99/3.3	7.99/3.3
Low Temp. Btuh [kW] Rating	60,000 [17.58]	60,000 [17.58]	60,000 [17.58]	60,000 [17.58]
System Power KW / COP	7.54/2.25	7.54/2.25	7.54/2.25	7.54/2.25
Compressor				
No./Type	1/Scroll	1/Scroll	1/Scroll	1/Scroll
Outdoor Sound Rating (dB)5	88	88	88	88
Outdoor Coil - Fin Type				
Tube Type	Louvered	Louvered	Louvered	Louvered
MicroChannel Depth in. [mm]	MicroChannel	MicroChannel	MicroChannel	MicroChannel
Face Area sq. ft. [sq. m]	1.26 [32]	1.26 [32]	1.26 [32]	1.26 [32]
Rows / FPI [FPcm]	22.4 [2.08]	22.4 [2.08]	22.4 [2.08]	22.4 [2.08]
Refrigerant Control	1 / 16 [6]	1 / 16 [6]	1 / 16 [6]	1 / 16 [6]
Indoor Coil - Fin Type				
Tube Type	TX Valves	TX Valves	TX Valves	TX Valves
MicroChannel Depth in. [mm]	Louvered	Louvered	Louvered	Louvered
Face Area sq. ft. [sq. m]	MicroChannel	MicroChannel	MicroChannel	MicroChannel
Rows / FPI [FPcm]	1.26 [32]	1.26 [32]	1.26 [32]	1.26 [32]
Refrigerant Control	10.9 [1.01]	10.9 [1.01]	10.9 [1.01]	10.9 [1.01]
Drain Connection No./Size in. [mm]	1 / 20 [8]	1 / 20 [8]	1 / 20 [8]	1 / 20 [8]
Outdoor Fan - Type				
No. Used/Diameter in. [mm]	Propeller	Propeller	Propeller	Propeller
Drive Type/No. Speeds	2/24 [609.6]	2/24 [609.6]	2/24 [609.6]	2/24 [609.6]
CFM [L/s]	Direct/1	Direct/1	Direct/1	Direct/1
No. Motors/HP	8000 [3775]	8000 [3775]	8000 [3775]	8000 [3775]
Motor RPM	2 at 1/2 HP	2 at 1/2 HP	2 at 1/2 HP	2 at 1/2 HP
Indoor Fan - Type				
No. Used/Diameter in. [mm]	1075	1075	1075	1075
Drive Type	FC Centrifugal	FC Centrifugal	FC Centrifugal	FC Centrifugal
No. Speeds	1/15x15 [381x381]	1/15x15 [381x381]	1/15x15 [381x381]	1/15x15 [381x381]
No. Motors	Belt (Adjustable)	Belt (Adjustable)	Belt (Adjustable)	Belt (Adjustable)
Motor HP	Single	Single	Single	Single
Motor RPM	1	1	1	1
Motor Frame Size	2	3	3	2
Filter - Type				
Furnished	Disposable	Disposable	Disposable	Disposable
(NO.) Size Recommended in. [mm x mm x mm]	Yes	Yes	Yes	Yes
Refrigerant Charge Oz. [g]				
	197 [5585]	197 [5585]	197 [5585]	197 [5585]
Weights				
Net Weight lbs. [kg]	811 [368]	821 [372]	822 [373]	811 [368]
Ship Weight lbs. [kg]	850 [386]	860 [390]	861 [391]	850 [386]

### NOTES:

- Cooling Performance is rated at 95° F ambient, 80° F entering dry bulb, 67° F entering wet bulb. Gross capacity does not include the effect of fan motor heat. AHRI capacity is net and includes the effect of fan motor heat. Units are suitable for operation to ±20% of nominal cfm. Units are certified in accordance with the Unitary Air Conditioner Equipment certification program, which is based on AHRI Standard 210/240 or 360.
- EER and/or SEER are rated at AHRI conditions and in accordance with DOE test procedures.
- Integrated Part Load Value is rated in accordance with AHRI Standard 210/240 or 360. Units are rated at 80° F ambient, 80° F entering dry bulb, and 67° F entering wet bulb at AHRI rated cfm.
- Outdoor Sound Rating shown is tested in accordance with AHRI Standard 270.

## GENERAL DATA

Model -HPDZS Series	102ADG	102ADH	102AYA	102AYB
Cooling Performance <sup>1</sup>				Continued ->
Gross Cooling Capacity Btu [kW]	101,000 [29.59]	101,000 [29.59]	101,000 [29.59]	101,000 [29.59]
EER/SEER2	11/NA	11/NA	11/NA	11/NA
Nominal CFM/AHRI Rated CFM [L/s]	3400/3345 [1604/1579]	3400/3345 [1604/1579]	3400/3345 [1604/1579]	3400/3345 [1604/1579]
AHRI Net Cooling Capacity Btu [kW]	98,000 [28.71]	98,000 [28.71]	98,000 [28.71]	98,000 [28.71]
Net Sensible Capacity Btu [kW]	71,000 [20.8]	71,000 [20.8]	71,000 [20.8]	71,000 [20.8]
Net Latent Capacity Btu [kW]	27,000 [7.91]	27,000 [7.91]	27,000 [7.91]	27,000 [7.91]
IEER3	12.2	12.2	12.2	12.2
Net System Power kW	8.47	8.47	8.47	8.47
Heating Performance (Heat Pumps)				
High Temp. Btuh [kW] Rating	98,000 [28.71]	98,000 [28.71]	98,000 [28.71]	98,000 [28.71]
System Power KW / COP	7.99/3.3	7.99/3.3	7.99/3.3	7.99/3.3
Low Temp. Btuh [kW] Rating	60,000 [17.58]	60,000 [17.58]	60,000 [17.58]	60,000 [17.58]
System Power KW / COP	7.54/2.25	7.54/2.25	7.54/2.25	7.54/2.25
Compressor				
No./Type	1/Scroll	1/Scroll	1/Scroll	1/Scroll
Outdoor Sound Rating (dB) <sup>5</sup>	88	88	88	88
Outdoor Coil - Fin Type				
Tube Type	Louvered	Louvered	Louvered	Louvered
MicroChannel Depth in. [mm]	MicroChannel	MicroChannel	MicroChannel	MicroChannel
Face Area sq. ft. [sq. m]	1.26 [32]	1.26 [32]	1.26 [32]	1.26 [32]
Rows / FPI [FPcm]	22.4 [2.08]	22.4 [2.08]	22.4 [2.08]	22.4 [2.08]
Refrigerant Control	1 / 16 [6]	1 / 16 [6]	1 / 16 [6]	1 / 16 [6]
Indoor Coil - Fin Type				
Tube Type	TX Valves	TX Valves	TX Valves	TX Valves
MicroChannel Depth in. [mm]	Louvered	Louvered	Louvered	Louvered
Face Area sq. ft. [sq. m]	MicroChannel	MicroChannel	MicroChannel	MicroChannel
Rows / FPI [FPcm]	1.26 [32]	1.26 [32]	1.26 [32]	1.26 [32]
Refrigerant Control	10.9 [1.01]	10.9 [1.01]	10.9 [1.01]	10.9 [1.01]
Drain Connection No./Size in. [mm]	1 / 20 [8]	1 / 20 [8]	1 / 20 [8]	1 / 20 [8]
Outdoor Fan - Type				
No. Used/Diameter in. [mm]	Propeller	Propeller	Propeller	Propeller
Drive Type/No. Speeds	2/24 [609.6]	2/24 [609.6]	2/24 [609.6]	2/24 [609.6]
CFM [L/s]	Direct/1	Direct/1	Direct/1	Direct/1
No. Motors/HP	8000 [3775]	8000 [3775]	8000 [3775]	8000 [3775]
Motor RPM	2 at 1/2 HP	2 at 1/2 HP	2 at 1/2 HP	2 at 1/2 HP
Indoor Fan - Type				
No. Used/Diameter in. [mm]	1075	1075	1075	1075
Drive Type	FC Centrifugal	FC Centrifugal	FC Centrifugal	FC Centrifugal
No. Speeds	1/15x15 [381x381]	1/15x15 [381x381]	1/15x15 [381x381]	1/15x15 [381x381]
No. Motors	Belt (Adjustable)	Belt (Adjustable)	Belt (Adjustable)	Belt (Adjustable)
Motor HP	Single	Single	Single	Single
Motor RPM	1	1	1	1
Motor Frame Size	3	3	3	3
Filter - Type				
Furnished	1725	1725	1725	1725
(NO.) Size Recommended in. [mm x mm x mm]	56	56	56	56
Refrigerant Charge Oz. [g]				
	Disposable	Disposable	Disposable	Disposable
	Yes	Yes	Yes	Yes
	(4)2x20x20 [51x508x508]	(4)2x20x20 [51x508x508]	(4)2x20x20 [51x508x508]	(4)2x20x20 [51x508x508]
Weights				
Net Weight lbs. [kg]	197 [5585]	197 [5585]	197 [5585]	197 [5585]
Ship Weight lbs. [kg]	821 [372]	822 [373]	811 [368]	821 [372]
	860 [390]	861 [391]	850 [386]	860 [390]

### NOTES:

- Cooling Performance is rated at 95° F ambient, 80° F entering dry bulb, 67° F entering wet bulb. Gross capacity does not include the effect of fan motor heat. AHRI capacity is net and includes the effect of fan motor heat. Units are suitable for operation to ±20% of nominal cfm. Units are certified in accordance with the Unitary Air Conditioner Equipment certification program, which is based on AHRI Standard 210/240 or 360.
- EER and/or SEER are rated at AHRI conditions and in accordance with DOE test procedures.
- Integrated Part Load Value is rated in accordance with AHRI Standard 210/240 or 360. Units are rated at 80° F ambient, 80° F entering dry bulb, and 67° F entering wet bulb at AHRI rated cfm.
- Outdoor Sound Rating shown is tested in accordance with AHRI Standard 270.

## GENERAL DATA

Model -HPDZS Series	102AYC	102AYF	102AYG	102AYH
Cooling Performance <sup>1</sup>				Continued ->
Gross Cooling Capacity Btu [kW]	101,000 [29.59]	101,000 [29.59]	101,000 [29.59]	101,000 [29.59]
EER/SEER2	11/NA	11/NA	11/NA	11/NA
Nominal CFM/AHRI Rated CFM [L/s]	3400/3345 [1604/1579]	3400/3345 [1604/1579]	3400/3345 [1604/1579]	3400/3345 [1604/1579]
AHRI Net Cooling Capacity Btu [kW]	98,000 [28.71]	98,000 [28.71]	98,000 [28.71]	98,000 [28.71]
Net Sensible Capacity Btu [kW]	71,000 [20.8]	71,000 [20.8]	71,000 [20.8]	71,000 [20.8]
Net Latent Capacity Btu [kW]	27,000 [7.91]	27,000 [7.91]	27,000 [7.91]	27,000 [7.91]
IEER3	12.2	12.2	12.2	12.2
Net System Power kW	8.47	8.47	8.47	8.47
Heating Performance (Heat Pumps)				
High Temp. Btuh [kW] Rating	98,000 [28.71]	98,000 [28.71]	98,000 [28.71]	98,000 [28.71]
System Power KW / COP	7.99/3.3	7.99/3.3	7.99/3.3	7.99/3.3
Low Temp. Btuh [kW] Rating	60,000 [17.58]	60,000 [17.58]	60,000 [17.58]	60,000 [17.58]
System Power KW / COP	7.54/2.25	7.54/2.25	7.54/2.25	7.54/2.25
Compressor				
No./Type	1/Scroll	1/Scroll	1/Scroll	1/Scroll
Outdoor Sound Rating (dB)5	88	88	88	88
Outdoor Coil - Fin Type				
Tube Type	Louvered	Louvered	Louvered	Louvered
MicroChannel Depth in. [mm]	MicroChannel	MicroChannel	MicroChannel	MicroChannel
Face Area sq. ft. [sq. m]	1.26 [32]	1.26 [32]	1.26 [32]	1.26 [32]
Rows / FPI [FPcm]	22.4 [2.08]	22.4 [2.08]	22.4 [2.08]	22.4 [2.08]
Refrigerant Control	1 / 16 [6]	1 / 16 [6]	1 / 16 [6]	1 / 16 [6]
Refrigerant Control	TX Valves	TX Valves	TX Valves	TX Valves
Indoor Coil - Fin Type				
Tube Type	Louvered	Louvered	Louvered	Louvered
MicroChannel Depth in. [mm]	MicroChannel	MicroChannel	MicroChannel	MicroChannel
Face Area sq. ft. [sq. m]	1.26 [32]	1.26 [32]	1.26 [32]	1.26 [32]
Rows / FPI [FPcm]	10.9 [1.01]	10.9 [1.01]	10.9 [1.01]	10.9 [1.01]
Refrigerant Control	1 / 20 [8]	1 / 20 [8]	1 / 20 [8]	1 / 20 [8]
Refrigerant Control	TX Valves	TX Valves	TX Valves	TX Valves
Drain Connection No./Size in. [mm]	1/0.75 [19.05]	1/0.75 [19.05]	1/0.75 [19.05]	1/0.75 [19.05]
Outdoor Fan - Type				
No. Used/Diameter in. [mm]	Propeller	Propeller	Propeller	Propeller
Drive Type/No. Speeds	2/24 [609.6]	2/24 [609.6]	2/24 [609.6]	2/24 [609.6]
CFM [L/s]	Direct/1	Direct/1	Direct/1	Direct/1
No. Motors/HP	8000 [3775]	8000 [3775]	8000 [3775]	8000 [3775]
Motor RPM	2 at 1/2 HP	2 at 1/2 HP	2 at 1/2 HP	2 at 1/2 HP
Motor RPM	1075	1075	1075	1075
Indoor Fan - Type				
No. Used/Diameter in. [mm]	FC Centrifugal	FC Centrifugal	FC Centrifugal	FC Centrifugal
Drive Type	1/15x15 [381x381]	1/15x15 [381x381]	1/15x15 [381x381]	1/15x15 [381x381]
No. Speeds	Belt (Adjustable)	Belt (Adjustable)	Belt (Adjustable)	Belt (Adjustable)
No. Motors	Single	Single	Single	Single
Motor HP	1	1	1	1
Motor RPM	3	2	3	3
Motor RPM	1725	1725	1725	1725
Motor Frame Size	56	56	56	56
Filter - Type				
Furnished	Disposable	Disposable	Disposable	Disposable
(NO.) Size Recommended in. [mm x mm x mm]	Yes	Yes	Yes	Yes
	(4)2x20x20 [51x508x508]	(4)2x20x20 [51x508x508]	(4)2x20x20 [51x508x508]	(4)2x20x20 [51x508x508]
Refrigerant Charge Oz. [g]	197 [5585]	197 [5585]	197 [5585]	197 [5585]
Weights				
Net Weight lbs. [kg]	822 [373]	811 [368]	821 [372]	822 [373]
Ship Weight lbs. [kg]	861 [391]	850 [386]	860 [390]	861 [391]

### NOTES:

- Cooling Performance is rated at 95° F ambient, 80° F entering dry bulb, 67° F entering wet bulb. Gross capacity does not include the effect of fan motor heat. AHRI capacity is net and includes the effect of fan motor heat. Units are suitable for operation to ±20% of nominal cfm. Units are certified in accordance with the Unitary Air Conditioner Equipment certification program, which is based on AHRI Standard 210/240 or 360.
- EER and/or SEER are rated at AHRI conditions and in accordance with DOE test procedures.
- Integrated Part Load Value is rated in accordance with AHRI Standard 210/240 or 360. Units are rated at 80° F ambient, 80° F entering dry bulb, and 67° F entering wet bulb at AHRI rated cfm.
- Outdoor Sound Rating shown is tested in accordance with AHRI Standard 270.

## GENERAL DATA

Model -HPDZS Series	120ACA	120ACB	120ACC	120ACF
Cooling Performance <sup>1</sup>				Continued ->
Gross Cooling Capacity Btu [kW]	119,000 [34.87]	119,000 [34.87]	119,000 [34.87]	119,000 [34.87]
EER/SEER2	11/NA	11/NA	11/NA	11/NA
Nominal CFM/AHRI Rated CFM [L/s]	4000/4060 [1888/1916]	4000/4060 [1888/1916]	4000/4060 [1888/1916]	4000/4060 [1888/1916]
AHRI Net Cooling Capacity Btu [kW]	114,000 [33.4]	114,000 [33.4]	114,000 [33.4]	114,000 [33.4]
Net Sensible Capacity Btu [kW]	82,800 [24.26]	82,800 [24.26]	82,800 [24.26]	82,800 [24.26]
Net Latent Capacity Btu [kW]	31,200 [9.14]	31,200 [9.14]	31,200 [9.14]	31,200 [9.14]
IEER3	12.2	12.2	12.2	12.2
Net System Power kW	10.13	10.13	10.13	10.13
Heating Performance (Heat Pumps)				
High Temp. Btuh [kW] Rating	112,000 [32.8]	112,000 [32.8]	112,000 [32.8]	112,000 [32.8]
System Power KW / COP	9.03/3.3	9.03/3.3	9.03/3.3	9.03/3.3
Low Temp. Btuh [kW] Rating	68,000 [20.0]	68,000 [20.0]	68,000 [20.0]	68,000 [20.0]
System Power KW / COP	8.3/2.25	8.3/2.25	8.3/2.25	8.3/2.25
Compressor				
No./Type	1/Scroll	1/Scroll	1/Scroll	1/Scroll
Outdoor Sound Rating (dB)5	88	88	88	88
Outdoor Coil - Fin Type				
Tube Type	Louvered	Louvered	Louvered	Louvered
MicroChannel Depth in. [mm]	MicroChannel	MicroChannel	MicroChannel	MicroChannel
Face Area sq. ft. [sq. m]	1.26 [32]	1.26 [32]	1.26 [32]	1.26 [32]
Rows / FPI [FPcm]	28.8 [2.68]	28.8 [2.68]	28.8 [2.68]	28.8 [2.68]
Refrigerant Control	1 / 16 [6]	1 / 16 [6]	1 / 16 [6]	1 / 16 [6]
Indoor Coil - Fin Type				
Tube Type	TX Valves	TX Valves	TX Valves	TX Valves
MicroChannel Depth in. [mm]	Louvered	Louvered	Louvered	Louvered
Face Area sq. ft. [sq. m]	MicroChannel	MicroChannel	MicroChannel	MicroChannel
Rows / FPI [FPcm]	1.26 [32]	1.26 [32]	1.26 [32]	1.26 [32]
Refrigerant Control	13.2 [1.23]	13.2 [1.23]	13.2 [1.23]	13.2 [1.23]
Drain Connection No./Size in. [mm]	1 / 20 [8]	1 / 20 [8]	1 / 20 [8]	1 / 20 [8]
Outdoor Fan - Type				
No. Used/Diameter in. [mm]	Propeller	Propeller	Propeller	Propeller
Drive Type/No. Speeds	2/24 [609.6]	2/24 [609.6]	2/24 [609.6]	2/24 [609.6]
CFM [L/s]	Direct/1	Direct/1	Direct/1	Direct/1
No. Motors/HP	8000 [3775]	8000 [3775]	8000 [3775]	8000 [3775]
Motor RPM	2 at 1/2 HP	2 at 1/2 HP	2 at 1/2 HP	2 at 1/2 HP
Indoor Fan - Type				
No. Used/Diameter in. [mm]	1075	1075	1075	1075
Drive Type	FC Centrifugal	FC Centrifugal	FC Centrifugal	FC Centrifugal
No. Speeds	1/15x15 [381x381]	1/15x15 [381x381]	1/15x15 [381x381]	1/15x15 [381x381]
No. Motors	Belt (Adjustable)	Belt (Adjustable)	Belt (Adjustable)	Belt (Adjustable)
Motor HP	Single	Single	Single	Single
Motor RPM	1	1	1	1
Motor Frame Size	2	3	3	2
Filter - Type				
Furnished	1725	1725	1725	1725
(NO.) Size Recommended in. [mm x mm x mm]	56	56	56	56
Refrigerant Charge Oz. [g]				
Weights	214.4 [6078.14]	214.4 [6078.14]	214.4 [6078.14]	214.4 [6078.14]
Net Weight lbs. [kg]	863 [391]	873 [396]	874 [396]	863 [391]
Ship Weight lbs. [kg]	902 [409]	912 [414]	913 [414]	902 [409]

### NOTES:

- Cooling Performance is rated at 95° F ambient, 80° F entering dry bulb, 67° F entering wet bulb. Gross capacity does not include the effect of fan motor heat. AHRI capacity is net and includes the effect of fan motor heat. Units are suitable for operation to ±20% of nominal cfm. Units are certified in accordance with the Unitary Air Conditioner Equipment certification program, which is based on AHRI Standard 210/240 or 360.
- EER and/or SEER are rated at AHRI conditions and in accordance with DOE test procedures.
- Integrated Part Load Value is rated in accordance with AHRI Standard 210/240 or 360. Units are rated at 80° F ambient, 80° F entering dry bulb, and 67° F entering wet bulb at AHRI rated cfm.
- Outdoor Sound Rating shown is tested in accordance with AHRI Standard 270.



## GENERAL DATA

Model -HPDZS Series	120ACG	120ACH	120ADA	120ADB
Cooling Performance <sup>1</sup>				Continued ->
Gross Cooling Capacity Btu [kW]	119,000 [34.87]	119,000 [34.87]	119,000 [34.87]	119,000 [34.87]
EER/SEER2	11/NA	11/NA	11/NA	11/NA
Nominal CFM/AHRI Rated CFM [L/s]	4000/4060 [1888/1916]	4000/4060 [1888/1916]	4000/4060 [1888/1916]	4000/4060 [1888/1916]
AHRI Net Cooling Capacity Btu [kW]	114,000 [33.4]	114,000 [33.4]	114,000 [33.4]	114,000 [33.4]
Net Sensible Capacity Btu [kW]	82,800 [24.26]	82,800 [24.26]	82,800 [24.26]	82,800 [24.26]
Net Latent Capacity Btu [kW]	31,200 [9.14]	31,200 [9.14]	31,200 [9.14]	31,200 [9.14]
IEER3	12.2	12.2	12.2	12.2
Net System Power kW	10.13	10.13	10.13	10.13
Heating Performance (Heat Pumps)				
High Temp. Btuh [kW] Rating	112,000 [32.8]	112,000 [32.8]	112,000 [32.8]	112,000 [32.8]
System Power KW / COP	9.03/3.3	9.03/3.3	9.03/3.3	9.03/3.3
Low Temp. Btuh [kW] Rating	68,000 [20.0]	68,000 [20.0]	68,000 [20.0]	68,000 [20.0]
System Power KW / COP	8.3/2.25	8.3/2.25	8.3/2.25	8.3/2.25
Compressor				
No./Type	1/Scroll	1/Scroll	1/Scroll	1/Scroll
Outdoor Sound Rating (dB) <sup>5</sup>	88	88	88	88
Outdoor Coil - Fin Type	Louvered	Louvered	Louvered	Louvered
Tube Type	MicroChannel	MicroChannel	MicroChannel	MicroChannel
MicroChannel Depth in. [mm]	1.26 [32]	1.26 [32]	1.26 [32]	1.26 [32]
Face Area sq. ft. [sq. m]	28.8 [2.68]	28.8 [2.68]	28.8 [2.68]	28.8 [2.68]
Rows / FPI [FPcm]	1 / 16 [6]	1 / 16 [6]	1 / 16 [6]	1 / 16 [6]
Refrigerant Control	TX Valves	TX Valves	TX Valves	TX Valves
Indoor Coil - Fin Type	Louvered	Louvered	Louvered	Louvered
Tube Type	MicroChannel	MicroChannel	MicroChannel	MicroChannel
MicroChannel Depth in. [mm]	1.26 [32]	1.26 [32]	1.26 [32]	1.26 [32]
Face Area sq. ft. [sq. m]	13.2 [1.23]	13.2 [1.23]	13.2 [1.23]	13.2 [1.23]
Rows / FPI [FPcm]	1 / 20 [8]	1 / 20 [8]	1 / 20 [8]	1 / 20 [8]
Refrigerant Control	TX Valves	TX Valves	TX Valves	TX Valves
Drain Connection No./Size in. [mm]	1/0.75 [19.05]	1/0.75 [19.05]	1/0.75 [19.05]	1/0.75 [19.05]
Outdoor Fan - Type	Propeller	Propeller	Propeller	Propeller
No. Used/Diameter in. [mm]	2/24 [609.6]	2/24 [609.6]	2/24 [609.6]	2/24 [609.6]
Drive Type/No. Speeds	Direct/1	Direct/1	Direct/1	Direct/1
CFM [L/s]	8000 [3775]	8000 [3775]	8000 [3775]	8000 [3775]
No. Motors/HP	2 at 1/2 HP	2 at 1/2 HP	2 at 1/2 HP	2 at 1/2 HP
Motor RPM	1075	1075	1075	1075
Indoor Fan - Type	FC Centrifugal	FC Centrifugal	FC Centrifugal	FC Centrifugal
No. Used/Diameter in. [mm]	1/15x15 [381x381]	1/15x15 [381x381]	1/15x15 [381x381]	1/15x15 [381x381]
Drive Type	Belt (Adjustable)	Belt (Adjustable)	Belt (Adjustable)	Belt (Adjustable)
No. Speeds	Single	Single	Single	Single
No. Motors	1	1	1	1
Motor HP	3	3	2	3
Motor RPM	1725	1725	1725	1725
Motor Frame Size	56	56	56	56
Filter - Type	Disposable	Disposable	Disposable	Disposable
Furnished	Yes	Yes	Yes	Yes
(NO.) Size Recommended in. [mm x mm x mm]	(4)2x25x20 [51x635x508]	(4)2x25x20 [51x635x508]	(4)2x25x20 [51x635x508]	(4)2x25x20 [51x635x508]
Refrigerant Charge Oz. [g]	214.4 [6078.14]	214.4 [6078.14]	214.4 [6078.14]	214.4 [6078.14]
Weights				
Net Weight lbs. [kg]	873 [396]	874 [396]	863 [391]	873 [396]
Ship Weight lbs. [kg]	912 [414]	913 [414]	902 [409]	912 [414]

### NOTES:

- Cooling Performance is rated at 95° F ambient, 80° F entering dry bulb, 67° F entering wet bulb. Gross capacity does not include the effect of fan motor heat. AHRI capacity is net and includes the effect of fan motor heat. Units are suitable for operation to ±20% of nominal cfm. Units are certified in accordance with the Unitary Air Conditioner Equipment certification program, which is based on AHRI Standard 210/240 or 360.
- EER and/or SEER are rated at AHRI conditions and in accordance with DOE test procedures.
- Integrated Part Load Value is rated in accordance with AHRI Standard 210/240 or 360. Units are rated at 80° F ambient, 80° F entering dry bulb, and 67° F entering wet bulb at AHRI rated cfm.
- Outdoor Sound Rating shown is tested in accordance with AHRI Standard 270.

## GENERAL DATA

Model -HPDZS Series	120ADC	120ADF	120ADG	120ADH
Cooling Performance <sup>1</sup>				Continued ->
Gross Cooling Capacity Btu [kW]	119,000 [34.87]	119,000 [34.87]	119,000 [34.87]	119,000 [34.87]
EER/SEER2	11/NA	11/NA	11/NA	11/NA
Nominal CFM/AHRI Rated CFM [L/s]	4000/4060 [1888/1916]	4000/4060 [1888/1916]	4000/4060 [1888/1916]	4000/4060 [1888/1916]
AHRI Net Cooling Capacity Btu [kW]	114,000 [33.4]	114,000 [33.4]	114,000 [33.4]	114,000 [33.4]
Net Sensible Capacity Btu [kW]	82,800 [24.26]	82,800 [24.26]	82,800 [24.26]	82,800 [24.26]
Net Latent Capacity Btu [kW]	31,200 [9.14]	31,200 [9.14]	31,200 [9.14]	31,200 [9.14]
IEER3	12.2	12.2	12.2	12.2
Net System Power kW	10.13	10.13	10.13	10.13
Heating Performance (Heat Pumps)				
High Temp. Btuh [kW] Rating	112,000 [32.8]	112,000 [32.8]	112,000 [32.8]	112,000 [32.8]
System Power KW / COP	9.03/3.3	9.03/3.3	9.03/3.3	9.03/3.3
Low Temp. Btuh [kW] Rating	68,000 [20.0]	68,000 [20.0]	68,000 [20.0]	68,000 [20.0]
System Power KW / COP	8.3/2.25	8.3/2.25	8.3/2.25	8.3/2.25
Compressor				
No./Type	1/Scroll	1/Scroll	1/Scroll	1/Scroll
Outdoor Sound Rating (dB)5	88	88	88	88
Outdoor Coil - Fin Type				
Tube Type	Louvered	Louvered	Louvered	Louvered
MicroChannel Depth in. [mm]	MicroChannel	MicroChannel	MicroChannel	MicroChannel
Face Area sq. ft. [sq. m]	1.26 [32]	1.26 [32]	1.26 [32]	0.26 [6.6]
Rows / FPI [FPcm]	28.8 [2.68]	28.8 [2.68]	28.8 [2.68]	28.8 [2.68]
Refrigerant Control	1 / 16 [6]	1 / 16 [6]	1 / 16 [6]	1 / 16 [6]
Indoor Coil - Fin Type				
Tube Type	Louvered	Louvered	Louvered	Louvered
MicroChannel Depth in. [mm]	MicroChannel	MicroChannel	MicroChannel	MicroChannel
Face Area sq. ft. [sq. m]	1.26 [32]	1.26 [32]	1.26 [32]	1.26 [32]
Rows / FPI [FPcm]	13.2 [1.23]	13.2 [1.23]	13.2 [1.23]	13.2 [1.23]
Refrigerant Control	1 / 20 [8]	1 / 20 [8]	1 / 20 [8]	1 / 20 [8]
Drain Connection No./Size in. [mm]	TX Valves	TX Valves	TX Valves	TX Valves
Outdoor Fan - Type				
No. Used/Diameter in. [mm]	Propeller	Propeller	Propeller	Propeller
Drive Type/No. Speeds	2/24 [609.6]	2/24 [609.6]	2/24 [609.6]	2/24 [609.6]
CFM [L/s]	Direct/1	Direct/1	Direct/1	Direct/1
No. Motors/HP	8000 [3775]	8000 [3775]	8000 [3775]	8000 [3775]
Motor RPM	2 at 1/2 HP	2 at 1/2 HP	2 at 1/2 HP	2 at 1/2 HP
Indoor Fan - Type				
No. Used/Diameter in. [mm]	FC Centrifugal	FC Centrifugal	FC Centrifugal	FC Centrifugal
Drive Type	1/15x15 [381x381]	1/15x15 [381x381]	1/15x15 [381x381]	1/15x15 [381x381]
No. Speeds	Belt (Adjustable)	Belt (Adjustable)	Belt (Adjustable)	Belt (Adjustable)
No. Motors	Single	Single	Single	Single
Motor HP	1	1	1	1
Motor RPM	3	2	3	3
Motor Frame Size	1725	1725	1725	1725
Filter - Type				
Furnished	Disposable	Disposable	Disposable	Disposable
(NO.) Size Recommended in. [mm x mm x mm]	Yes	Yes	Yes	Yes
Refrigerant Charge Oz. [g]				
	214.4 [6078.14]	214.4 [6078.14]	214.4 [6078.14]	214.4 [6078.14]
Weights				
Net Weight lbs. [kg]	874 [396]	863 [391]	873 [396]	874 [396]
Ship Weight lbs. [kg]	913 [414]	902 [409]	912 [414]	913 [414]

### NOTES:

- Cooling Performance is rated at 95° F ambient, 80° F entering dry bulb, 67° F entering wet bulb. Gross capacity does not include the effect of fan motor heat. AHRI capacity is net and includes the effect of fan motor heat. Units are suitable for operation to ±20% of nominal cfm. Units are certified in accordance with the Unitary Air Conditioner Equipment certification program, which is based on AHRI Standard 210/240 or 360.
- EER and/or SEER are rated at AHRI conditions and in accordance with DOE test procedures.
- Integrated Part Load Value is rated in accordance with AHRI Standard 210/240 or 360. Units are rated at 80° F ambient, 80° F entering dry bulb, and 67° F entering wet bulb at AHRI rated cfm.
- Outdoor Sound Rating shown is tested in accordance with AHRI Standard 270.



## GENERAL DATA

Model -HPDZS Series	120AYA	120AYB	120AYC	120AYF
Cooling Performance <sup>1</sup>				Continued ->
Gross Cooling Capacity Btu [kW]	119,000 [34.87]	119,000 [34.87]	119,000 [34.87]	119,000 [34.87]
EER/SEER2	11/NA	11/NA	11/NA	11/NA
Nominal CFM/AHRI Rated CFM [L/s]	4000/4060 [1888/1916]	4000/4060 [1888/1916]	4000/4060 [1888/1916]	4000/4060 [1888/1916]
AHRI Net Cooling Capacity Btu [kW]	114,000 [33.4]	114,000 [33.4]	114,000 [33.4]	114,000 [33.4]
Net Sensible Capacity Btu [kW]	82,800 [24.26]	82,800 [24.26]	82,800 [24.26]	82,800 [24.26]
Net Latent Capacity Btu [kW]	31,200 [9.14]	31,200 [9.14]	31,200 [9.14]	31,200 [9.14]
IEER3	12.2	12.2	12.2	12.2
Net System Power kW	10.13	10.13	10.13	10.13
Heating Performance (Heat Pumps)				
High Temp. Btuh [kW] Rating	112,000 [32.8]	112,000 [32.8]	112,000 [32.8]	112,000 [32.8]
System Power KW / COP	9.03/3.3	9.03/3.3	9.03/3.3	9.03/3.3
Low Temp. Btuh [kW] Rating	68,000 [20.0]	68,000 [20.0]	68,000 [20.0]	68,000 [20.0]
System Power KW / COP	8.3/2.25	8.3/2.25	8.3/2.25	8.3/2.25
Compressor				
No./Type	1/Scroll	1/Scroll	1/Scroll	1/Scroll
Outdoor Sound Rating (dB)5	88	88	88	88
Outdoor Coil - Fin Type	Louvered	Louvered	Louvered	Louvered
Tube Type	MicroChannel	MicroChannel	MicroChannel	MicroChannel
MicroChannel Depth in. [mm]	1.26 [32]	1.26 [32]	1.26 [32]	1.26 [32]
Face Area sq. ft. [sq. m]	28.8 [2.68]	28.8 [2.68]	28.8 [2.68]	28.8 [2.68]
Rows / FPI [FPcm]	1 / 16 [6]	1 / 16 [6]	1 / 16 [6]	1 / 16 [6]
Refrigerant Control	TX Valves	TX Valves	TX Valves	TX Valves
Indoor Coil - Fin Type	Louvered	Louvered	Louvered	Louvered
Tube Type	MicroChannel	MicroChannel	MicroChannel	MicroChannel
MicroChannel Depth in. [mm]	1.26 [32]	1.26 [32]	1.26 [32]	1.26 [32]
Face Area sq. ft. [sq. m]	13.2 [1.23]	13.2 [1.23]	13.2 [1.23]	13.2 [1.23]
Rows / FPI [FPcm]	1 / 20 [8]	1 / 20 [8]	1 / 20 [8]	1 / 20 [8]
Refrigerant Control	TX Valves	TX Valves	TX Valves	TX Valves
Drain Connection No./Size in. [mm]	1/0.75 [19.05]	1/0.75 [19.05]	1/0.75 [19.05]	1/0.75 [19.05]
Outdoor Fan - Type	Propeller	Propeller	Propeller	Propeller
No. Used/Diameter in. [mm]	2/24 [609.6]	2/24 [609.6]	2/24 [609.6]	2/24 [609.6]
Drive Type/No. Speeds	Direct/1	Direct/1	Direct/1	Direct/1
CFM [L/s]	8000 [3775]	8000 [3775]	8000 [3775]	8000 [3775]
No. Motors/HP	2 at 1/2 HP	2 at 1/2 HP	2 at 1/2 HP	2 at 1/2 HP
Motor RPM	1075	1075	1075	1075
Indoor Fan - Type	FC Centrifugal	FC Centrifugal	FC Centrifugal	FC Centrifugal
No. Used/Diameter in. [mm]	1/15x15 [381x381]	1/15x15 [381x381]	1/15x15 [381x381]	1/15x15 [381x381]
Drive Type	Belt (Adjustable)	Belt (Adjustable)	Belt (Adjustable)	Belt (Adjustable)
No. Speeds	Single	Single	Single	Single
No. Motors	1	1	1	1
Motor HP	2	3	3	2
Motor RPM	1725	1725	1725	1725
Motor Frame Size	56	56	56	56
Filter - Type	Disposable	Disposable	Disposable	Disposable
Furnished	Yes	Yes	Yes	Yes
(NO.) Size Recommended in. [mm x mm x mm]	(4)2x25x20 [51x635x508]	(4)2x25x20 [51x635x508]	(4)2x25x20 [51x635x508]	(4)2x25x20 [51x635x508]
Refrigerant Charge Oz. [g]	214.4 [6078.14]	214.4 [6078.14]	214.4 [6078.14]	214.4 [6078.14]
Weights				
Net Weight lbs. [kg]	863 [391]	873 [396]	874 [396]	863 [391]
Ship Weight lbs. [kg]	902 [409]	912 [414]	913 [414]	902 [409]

### NOTES:

- Cooling Performance is rated at 95° F ambient, 80° F entering dry bulb, 67° F entering wet bulb. Gross capacity does not include the effect of fan motor heat. AHRI capacity is net and includes the effect of fan motor heat. Units are suitable for operation to ±20% of nominal cfm. Units are certified in accordance with the Unitary Air Conditioner Equipment certification program, which is based on AHRI Standard 210/240 or 360.
- EER and/or SEER are rated at AHRI conditions and in accordance with DOE test procedures.
- Integrated Part Load Value is rated in accordance with AHRI Standard 210/240 or 360. Units are rated at 80° F ambient, 80° F entering dry bulb, and 67° F entering wet bulb at AHRI rated cfm.
- Outdoor Sound Rating shown is tested in accordance with AHRI Standard 270.

## GENERAL DATA

Model -HPDZS Series	120AYG	120AYH
<b>Continued -&gt;</b>		
<b>Cooling Performance<sup>1</sup></b>		
Gross Cooling Capacity Btu [kW]	119,000 [34.87]	119,000 [34.87]
EER/SEER <sup>2</sup>	11/NA	11/NA
Nominal CFM/AHRI Rated CFM [L/s]	4000/4060 [1888/1916]	4000/4060 [1888/1916]
AHRI Net Cooling Capacity Btu [kW]	114,000 [33.4]	114,000 [33.4]
Net Sensible Capacity Btu [kW]	82,800 [24.26]	82,800 [24.26]
Net Latent Capacity Btu [kW]	31,200 [9.14]	31,200 [9.14]
IEER <sup>3</sup>	12.2	12.2
Net System Power kW	10.13	10.13
<b>Heating Performance (Heat Pumps)</b>		
High Temp. Btuh [kW] Rating	112,000 [32.8]	112,000 [32.8]
System Power KW / COP	9.03/3.3	9.03/3.3
Low Temp. Btuh [kW] Rating	68,000 [20.0]	68,000 [20.0]
System Power KW / COP	8.3/2.25	8.3/2.25
<b>Compressor</b>		
No./Type	1/Scroll	1/Scroll
<b>Outdoor Sound Rating (dB)<sup>5</sup></b>		
	88	88
<b>Outdoor Coil - Fin Type</b>		
Tube Type	Louvered	Louvered
MicroChannel Depth in. [mm]	1.26 [32]	1.26 [32]
Face Area sq. ft. [sq. m]	28.8 [2.68]	28.8 [2.68]
Rows / FPI [FPcm]	1 / 16 [6]	1 / 16 [6]
Refrigerant Control	TX Valves	TX Valves
<b>Indoor Coil - Fin Type</b>		
Tube Type	Louvered	Louvered
MicroChannel Depth in. [mm]	1.26 [32]	1.26 [32]
Face Area sq. ft. [sq. m]	13.2 [1.23]	13.2 [1.23]
Rows / FPI [FPcm]	1 / 20 [8]	1 / 20 [8]
Refrigerant Control	TX Valves	TX Valves
Drain Connection No./Size in. [mm]	1/0.75 [19.05]	1/0.75 [19.05]
<b>Outdoor Fan - Type</b>		
No. Used/Diameter in. [mm]	2/24 [609.6]	2/24 [609.6]
Drive Type/No. Speeds	Direct/1	Direct/1
CFM [L/s]	8000 [3775]	8000 [3775]
No. Motors/HP	2 at 1/2 HP	2 at 1/2 HP
Motor RPM	1075	1075
<b>Indoor Fan - Type</b>		
No. Used/Diameter in. [mm]	1/15x15 [381x381]	1/15x15 [381x381]
Drive Type	Belt (Adjustable)	Belt (Adjustable)
No. Speeds	Single	Single
No. Motors	1	1
Motor HP	3	3
Motor RPM	1725	1725
Motor Frame Size	56	56
<b>Filter - Type</b>		
Furnished	Yes	Yes
(NO.) Size Recommended in. [mm x mm x mm]	(4)2x25x20 [51x635x508]	(4)2x25x20 [51x635x508]
<b>Refrigerant Charge Oz. [g]</b>		
	214.4 [6078.14]	214.4 [6078.14]
<b>Weights</b>		
Net Weight lbs. [kg]	873 [396]	874 [396]
Ship Weight lbs. [kg]	912 [414]	913 [414]

### NOTES:

- Cooling Performance is rated at 95° F ambient, 80° F entering dry bulb, 67° F entering wet bulb. Gross capacity does not include the effect of fan motor heat. AHRI capacity is net and includes the effect of fan motor heat. Units are suitable for operation to ±20% of nominal cfm. Units are certified in accordance with the Unitary Air Conditioner Equipment certification program, which is based on AHRI Standard 210/240 or 360.
- EER and/or SEER are rated at AHRI conditions and in accordance with DOE test procedures.
- Integrated Part Load Value is rated in accordance with AHRI Standard 210/240 or 360. Units are rated at 80° F ambient, 80° F entering dry bulb, and 67° F entering wet bulb at AHRI rated cfm.
- Outdoor Sound Rating shown is tested in accordance with AHRI Standard 270.

## GENERAL DATA

Model -HPDZT Series	090ACF	090ACG	090ACH	090ADF
Cooling Performance <sup>1</sup>				Continued ->
Gross Cooling Capacity Btu [kW]	89,000 [26.08]	89,000 [26.08]	89,000 [26.08]	89,000 [26.08]
EER/SEER <sup>2</sup>	11/NA	11/NA	11/NA	11/NA
Nominal CFM/AHRI Rated CFM [L/s]	3000/3030 [1416/1430]	3000/3030 [1416/1430]	3000/3030 [1416/1430]	3000/3030 [1416/1430]
AHRI Net Cooling Capacity Btu [kW]	86,000 [25.2]	86,000 [25.2]	86,000 [25.2]	86,000 [25.2]
Net Sensible Capacity Btu [kW]	62,800 [18.4]	62,800 [18.4]	62,800 [18.4]	62,800 [18.4]
Net Latent Capacity Btu [kW]	23,200 [6.8]	23,200 [6.8]	23,200 [6.8]	23,200 [6.8]
IEER <sup>3</sup>	14.1	14.1	14.1	14.1
Net System Power kW	7.55	7.55	7.55	7.55
Heating Performance (Heat Pumps)				
High Temp. Btuh [kW] Rating	84,000 [24.6]	84,000 [24.6]	84,000 [24.6]	84,000 [24.6]
System Power KW / COP	6.84/3.4	6.84/3.4	6.84/3.4	6.84/3.4
Low Temp. Btuh [kW] Rating	48,000 [14.06]	48,000 [14.06]	48,000 [14.06]	48,000 [14.06]
System Power KW / COP	6.44/2.25	6.44/2.25	6.44/2.25	6.44/2.25
Compressor				
No./Type	1/Scroll	1/Scroll	1/Scroll	1/Scroll
Outdoor Sound Rating (dB) <sup>5</sup>	88	88	88	88
Outdoor Coil - Fin Type	Louvered	Louvered	Louvered	Louvered
Tube Type	MicroChannel	MicroChannel	MicroChannel	MicroChannel
MicroChannel Depth in. [mm]	1 [25.4]	1 [25.4]	1 [25.4]	1 [25.4]
Face Area sq. ft. [sq. m]	22.8 [2.12]	22.8 [2.12]	22.8 [2.12]	22.8 [2.12]
Rows / FPI [FPcm]	1 / 16 [6]	1 / 16 [6]	1 / 16 [6]	1 / 16 [6]
Refrigerant Control	TX Valves	TX Valves	TX Valves	TX Valves
Indoor Coil - Fin Type	Louvered	Louvered	Louvered	Louvered
Tube Type	MicroChannel	MicroChannel	MicroChannel	MicroChannel
MicroChannel Depth in. [mm]	1.26 [32]	1.26 [32]	1.26 [32]	1.26 [32]
Face Area sq. ft. [sq. m]	10.9 [1.01]	10.9 [1.01]	10.9 [1.01]	10.9 [1.01]
Rows / FPI [FPcm]	1 / 20 [8]	1 / 20 [8]	1 / 20 [8]	1 / 20 [8]
Refrigerant Control	TX Valves	TX Valves	TX Valves	TX Valves
Drain Connection No./Size in. [mm]	1/0.75 [19.05]	1/0.75 [19.05]	1/0.75 [19.05]	1/0.75 [19.05]
Outdoor Fan - Type	Propeller	Propeller	Propeller	Propeller
No. Used/Diameter in. [mm]	2/24 [609.6]	2/24 [609.6]	2/24 [609.6]	2/24 [609.6]
Drive Type/No. Speeds	Direct/1	Direct/1	Direct/1	Direct/1
CFM [L/s]	8000 [3775]	8000 [3775]	8000 [3775]	8000 [3775]
No. Motors/HP	2 at 1/2 HP	2 at 1/2 HP	2 at 1/2 HP	2 at 1/2 HP
Motor RPM	1075	1075	1075	1075
Indoor Fan - Type	FC Centrifugal	FC Centrifugal	FC Centrifugal	FC Centrifugal
No. Used/Diameter in. [mm]	1/15x15 [381x381]	1/15x15 [381x381]	1/15x15 [381x381]	1/15x15 [381x381]
Drive Type	Belt (Adjustable)	Belt (Adjustable)	Belt (Adjustable)	Belt (Adjustable)
No. Speeds	Dual	Dual	Dual	Dual
No. Motors	1	1	1	1
Motor HP	2	3	3	2
Motor RPM	1725	1725	1725	1725
Motor Frame Size	56	56	56	56
Filter - Type	Disposable	Disposable	Disposable	Disposable
Furnished	Yes	Yes	Yes	Yes
(NO.) Size Recommended in. [mm x mm x mm]	(4)2x20x20 [51x508x508]	(4)2x20x20 [51x508x508]	(4)2x20x20 [51x508x508]	(4)2x20x20 [51x508x508]
Refrigerant Charge Oz. [g]	179 [5075]	179 [5075]	179 [5075]	179 [5075]
Weights				
Net Weight lbs. [kg]	775 [352]	785 [356]	786 [357]	775 [352]
Ship Weight lbs. [kg]	814 [369]	824 [374]	825 [374]	814 [369]

### NOTES:

- Cooling Performance is rated at 95° F ambient, 80° F entering dry bulb, 67° F entering wet bulb. Gross capacity does not include the effect of fan motor heat. AHRI capacity is net and includes the effect of fan motor heat. Units are suitable for operation to ±20% of nominal cfm. Units are certified in accordance with the Unitary Air Conditioner Equipment certification program, which is based on AHRI Standard 210/240 or 360.
- EER and/or SEER are rated at AHRI conditions and in accordance with DOE test procedures.
- Integrated Part Load Value is rated in accordance with AHRI Standard 210/240 or 360. Units are rated at 80° F ambient, 80° F entering dry bulb, and 67° F entering wet bulb at AHRI rated cfm.
- Outdoor Sound Rating shown is tested in accordance with AHRI Standard 270.

## GENERAL DATA

Model -HPDZT Series	090ADG	090ADH	090AYF	090AYG
Cooling Performance <sup>1</sup>				Continued ->
Gross Cooling Capacity Btu [kW]	89,000 [26.08]	89,000 [26.08]	89,000 [26.08]	89,000 [26.08]
EER/SEER <sup>2</sup>	11/NA	11/NA	11/NA	11/NA
Nominal CFM/AHRI Rated CFM [L/s]	3000/3030 [1416/1430]	3000/3030 [1416/1430]	3000/3030 [1416/1430]	3000/3030 [1416/1430]
AHRI Net Cooling Capacity Btu [kW]	86,000 [25.2]	86,000 [25.2]	86,000 [25.2]	86,000 [25.2]
Net Sensible Capacity Btu [kW]	62,800 [18.4]	62,800 [18.4]	62,800 [18.4]	62,800 [18.4]
Net Latent Capacity Btu [kW]	23,200 [6.8]	23,200 [6.8]	23,200 [6.8]	23,200 [6.8]
IEER <sup>3</sup>	14.1	14.1	14.1	14.1
Net System Power kW	7.55	7.55	7.55	7.55
Heating Performance (Heat Pumps)				
High Temp. Btuh [kW] Rating	84,000 [24.6]	84,000 [24.6]	84,000 [24.6]	84,000 [24.6]
System Power KW / COP	6.84/3.4	6.84/3.4	6.84/3.4	6.84/3.4
Low Temp. Btuh [kW] Rating	48,000 [14.06]	48,000 [14.06]	48,000 [14.06]	48,000 [14.06]
System Power KW / COP	6.44/2.25	6.44/2.25	6.44/2.25	6.44/2.25
Compressor				
No./Type	1/Scroll	1/Scroll	1/Scroll	1/Scroll
Outdoor Sound Rating (dB) <sup>5</sup>	88	88	88	88
Outdoor Coil - Fin Type				
Tube Type	Louvered	Louvered	Louvered	Louvered
MicroChannel Depth in. [mm]	1 [25.4]	1 [25.4]	1 [25.4]	1 [25.4]
Face Area sq. ft. [sq. m]	22.8 [2.12]	22.8 [2.12]	22.8 [2.12]	22.8 [2.12]
Rows / FPI [FPcm]	1 / 16 [6]	1 / 16 [6]	1 / 16 [6]	1 / 16 [6]
Refrigerant Control	TX Valves	TX Valves	TX Valves	TX Valves
Indoor Coil - Fin Type				
Tube Type	Louvered	Louvered	Louvered	Louvered
MicroChannel Depth in. [mm]	1.26 [32]	1.26 [32]	1.26 [32]	1.26 [32]
Face Area sq. ft. [sq. m]	10.9 [1.01]	10.9 [1.01]	10.9 [1.01]	10.9 [1.01]
Rows / FPI [FPcm]	1 / 20 [8]	1 / 20 [8]	1 / 20 [8]	1 / 20 [8]
Refrigerant Control	TX Valves	TX Valves	TX Valves	TX Valves
Drain Connection No./Size in. [mm]	1/0.75 [19.05]	1/0.75 [19.05]	1/0.75 [19.05]	1/0.75 [19.05]
Outdoor Fan - Type				
No. Used/Diameter in. [mm]	2/24 [609.6]	2/24 [609.6]	2/24 [609.6]	2/24 [609.6]
Drive Type/No. Speeds	Direct/1	Direct/1	Direct/1	Direct/1
CFM [L/s]	8000 [3775]	8000 [3775]	8000 [3775]	8000 [3775]
No. Motors/HP	2 at 1/2 HP	2 at 1/2 HP	2 at 1/2 HP	2 at 1/2 HP
Motor RPM	1075	1075	1075	1075
Indoor Fan - Type				
No. Used/Diameter in. [mm]	1/15x15 [381x381]	1/15x15 [381x381]	1/15x15 [381x381]	1/15x15 [381x381]
Drive Type	Belt (Adjustable)	Belt (Adjustable)	Belt (Adjustable)	Belt (Adjustable)
No. Speeds	Dual	Dual	Dual	Dual
No. Motors	1	1	1	1
Motor HP	3	3	2	3
Motor RPM	1725	1725	1725	1725
Motor Frame Size	56	56	56	56
Filter - Type				
Furnished	Yes	Yes	Yes	Yes
(NO.) Size Recommended in. [mm x mm x mm]	(4)2x20x20 [51x508x508]	(4)2x20x20 [51x508x508]	(4)2x20x20 [51x508x508]	(4)2x20x20 [51x508x508]
Refrigerant Charge Oz. [g]	179 [5075]	179 [5075]	179 [5075]	179 [5075]
Weights				
Net Weight lbs. [kg]	785 [356]	786 [357]	775 [352]	785 [356]
Ship Weight lbs. [kg]	824 [374]	825 [374]	814 [369]	824 [374]

### NOTES:

- Cooling Performance is rated at 95° F ambient, 80° F entering dry bulb, 67° F entering wet bulb. Gross capacity does not include the effect of fan motor heat. AHRI capacity is net and includes the effect of fan motor heat. Units are suitable for operation to ±20% of nominal cfm. Units are certified in accordance with the Unitary Air Conditioner Equipment certification program, which is based on AHRI Standard 210/240 or 360.
- EER and/or SEER are rated at AHRI conditions and in accordance with DOE test procedures.
- Integrated Part Load Value is rated in accordance with AHRI Standard 210/240 or 360. Units are rated at 80° F ambient, 80° F entering dry bulb, and 67° F entering wet bulb at AHRI rated cfm.
- Outdoor Sound Rating shown is tested in accordance with AHRI Standard 270.

## GENERAL DATA

Model -HPDZT Series	090AYH	102ACF	102ACG	102ACH
Cooling Performance <sup>1</sup>				Continued ->
Gross Cooling Capacity Btu [kW]	89,000 [26.08]	101,000 [29.59]	101,000 [29.59]	101,000 [29.59]
EER/SEER <sup>2</sup>	11/NA	11/NA	11/NA	11/NA
Nominal CFM/AHRI Rated CFM [L/s]	3000/3030 [1416/1430]	3400/3345 [1604/1579]	3400/3345 [1604/1579]	3400/3345 [1604/1579]
AHRI Net Cooling Capacity Btu [kW]	86,000 [25.2]	98,000 [28.71]	98,000 [28.71]	98,000 [28.71]
Net Sensible Capacity Btu [kW]	62,800 [18.4]	71,000 [20.8]	71,000 [20.8]	71,000 [20.8]
Net Latent Capacity Btu [kW]	23,200 [6.8]	27,000 [7.91]	27,000 [7.91]	27,000 [7.91]
IEER <sup>3</sup>	14.1	14.1	14.1	14.1
Net System Power kW	7.55	8.47	8.47	8.47
Heating Performance (Heat Pumps)				
High Temp. Btuh [kW] Rating	84,000 [24.6]	98,000 [28.71]	98,000 [28.71]	98,000 [28.71]
System Power KW / COP	6.84/3.4	7.99/3.4	7.99/3.4	7.99/3.4
Low Temp. Btuh [kW] Rating	48,000 [14.06]	60,000 [17.58]	60,000 [17.58]	60,000 [17.58]
System Power KW / COP	6.44/2.25	7.54/2.25	7.54/2.25	7.54/2.25
Compressor				
No./Type	1/Scroll	1/Scroll	1/Scroll	1/Scroll
Outdoor Sound Rating (dB) <sup>5</sup>	88	88	88	88
Outdoor Coil - Fin Type	Louvered	Louvered	Louvered	Louvered
Tube Type	MicroChannel	MicroChannel	MicroChannel	MicroChannel
MicroChannel Depth in. [mm]	1 [25.4]	1.26 [32]	1.26 [32]	1.26 [32]
Face Area sq. ft. [sq. m]	22.8 [2.12]	22.4 [2.08]	22.4 [2.08]	22.4 [2.08]
Rows / FPI [FPcm]	1 / 16 [6]	1 / 16 [6]	1 / 16 [6]	1 / 16 [6]
Refrigerant Control	TX Valves	TX Valves	TX Valves	TX Valves
Indoor Coil - Fin Type	Louvered	Louvered	Louvered	Louvered
Tube Type	MicroChannel	MicroChannel	MicroChannel	MicroChannel
MicroChannel Depth in. [mm]	1.26 [32]	1.26 [32]	1.26 [32]	1.26 [32]
Face Area sq. ft. [sq. m]	10.9 [1.01]	10.9 [1.01]	10.9 [1.01]	10.9 [1.01]
Rows / FPI [FPcm]	1 / 20 [8]	1 / 20 [8]	1 / 20 [8]	1 / 20 [8]
Refrigerant Control	TX Valves	TX Valves	TX Valves	TX Valves
Drain Connection No./Size in. [mm]	1/0.75 [19.05]	1/0.75 [19.05]	1/0.75 [19.05]	1/0.75 [19.05]
Outdoor Fan - Type	Propeller	Propeller	Propeller	Propeller
No. Used/Diameter in. [mm]	2/24 [609.6]	2/24 [609.6]	2/24 [609.6]	2/24 [609.6]
Drive Type/No. Speeds	Direct/1	Direct/1	Direct/1	Direct/1
CFM [L/s]	8000 [3775]	8000 [3775]	8000 [3775]	8000 [3775]
No. Motors/HP	2 at 1/2 HP	2 at 1/2 HP	2 at 1/2 HP	2 at 1/2 HP
Motor RPM	1075	1075	1075	1075
Indoor Fan - Type	FC Centrifugal	FC Centrifugal	FC Centrifugal	FC Centrifugal
No. Used/Diameter in. [mm]	1/15x15 [381x381]	1/15x15 [381x381]	1/15x15 [381x381]	1/15x15 [381x381]
Drive Type	Belt (Adjustable)	Belt (Adjustable)	Belt (Adjustable)	Belt (Adjustable)
No. Speeds	Dual	Dual	Dual	Dual
No. Motors	1	1	1	1
Motor HP	3	2	3	3
Motor RPM	1725	1725	1725	1725
Motor Frame Size	56	56	56	56
Filter - Type	Disposable	Disposable	Disposable	Disposable
Furnished	Yes	Yes	Yes	Yes
(NO.) Size Recommended in. [mm x mm x mm]	(4)2x20x20 [51x508x508]	(4)2x20x20 [51x508x508]	(4)2x20x20 [51x508x508]	(4)2x20x20 [51x508x508]
Refrigerant Charge Oz. [g]	179 [5075]	197 [5585]	197 [5585]	197 [5585]
Weights				
Net Weight lbs. [kg]	786 [357]	811 [368]	821 [372]	822 [373]
Ship Weight lbs. [kg]	825 [374]	850 [386]	860 [390]	861 [391]

### NOTES:

- Cooling Performance is rated at 95° F ambient, 80° F entering dry bulb, 67° F entering wet bulb. Gross capacity does not include the effect of fan motor heat. AHRI capacity is net and includes the effect of fan motor heat. Units are suitable for operation to ±20% of nominal cfm. Units are certified in accordance with the Unitary Air Conditioner Equipment certification program, which is based on AHRI Standard 210/240 or 360.
- EER and/or SEER are rated at AHRI conditions and in accordance with DOE test procedures.
- Integrated Part Load Value is rated in accordance with AHRI Standard 210/240 or 360. Units are rated at 80° F ambient, 80° F entering dry bulb, and 67° F entering wet bulb at AHRI rated cfm.
- Outdoor Sound Rating shown is tested in accordance with AHRI Standard 270.

## GENERAL DATA

Model -HPDZT Series	102ADF	102ADG	102ADH	102AYF
Cooling Performance <sup>1</sup>				Continued ->
Gross Cooling Capacity Btu [kW]	101,000 [29.59]	101,000 [29.59]	101,000 [29.59]	101,000 [29.59]
EER/SEER <sup>2</sup>	11/NA	11/NA	11/NA	11/NA
Nominal CFM/AHRI Rated CFM [L/s]	3400/3345 [1604/1579]	3400/3345 [1604/1579]	3400/3345 [1604/1579]	3400/3345 [1604/1579]
AHRI Net Cooling Capacity Btu [kW]	98,000 [28.71]	98,000 [28.71]	98,000 [28.71]	98,000 [28.71]
Net Sensible Capacity Btu [kW]	71,000 [20.8]	71,000 [20.8]	71,000 [20.8]	71,000 [20.8]
Net Latent Capacity Btu [kW]	27,000 [7.91]	27,000 [7.91]	27,000 [7.91]	27,000 [7.91]
IEER <sup>3</sup>	14.1	14.1	14.1	14.1
Net System Power kW	8.47	8.47	8.47	8.47
Heating Performance (Heat Pumps)				
High Temp. Btuh [kW] Rating	98,000 [28.71]	98,000 [28.71]	98,000 [28.71]	98,000 [28.71]
System Power KW / COP	7.99/3.4	7.99/3.4	7.99/3.4	7.99/3.4
Low Temp. Btuh [kW] Rating	60,000 [17.58]	60,000 [17.58]	60,000 [17.58]	60,000 [17.58]
System Power KW / COP	7.54/2.25	7.54/2.25	7.54/2.25	7.54/2.25
Compressor				
No./Type	1/Scroll	1/Scroll	1/Scroll	1/Scroll
Outdoor Sound Rating (dB) <sup>5</sup>	88	88	88	88
Outdoor Coil - Fin Type	Louvered	Louvered	Louvered	Louvered
Tube Type	MicroChannel	MicroChannel	MicroChannel	MicroChannel
MicroChannel Depth in. [mm]	1.26 [32]	1.26 [32]	1.26 [32]	1.26 [32]
Face Area sq. ft. [sq. m]	22.4 [2.08]	22.4 [2.08]	22.4 [2.08]	22.4 [2.08]
Rows / FPI [FPcm]	1 / 16 [6]	1 / 16 [6]	1 / 16 [6]	1 / 16 [6]
Refrigerant Control	TX Valves	TX Valves	TX Valves	TX Valves
Indoor Coil - Fin Type	Louvered	Louvered	Louvered	Louvered
Tube Type	MicroChannel	MicroChannel	MicroChannel	MicroChannel
MicroChannel Depth in. [mm]	1.26 [32]	1.26 [32]	1.26 [32]	1.26 [32]
Face Area sq. ft. [sq. m]	10.9 [1.01]	10.9 [1.01]	10.9 [1.01]	10.9 [1.01]
Rows / FPI [FPcm]	1 / 20 [8]	1 / 20 [8]	1 / 20 [8]	1 / 20 [8]
Refrigerant Control	TX Valves	TX Valves	TX Valves	TX Valves
Drain Connection No./Size in. [mm]	1/0.75 [19.05]	1/0.75 [19.05]	1/0.75 [19.05]	1/0.75 [19.05]
Outdoor Fan - Type	Propeller	Propeller	Propeller	Propeller
No. Used/Diameter in. [mm]	2/24 [609.6]	2/24 [609.6]	2/24 [609.6]	2/24 [609.6]
Drive Type/No. Speeds	Direct/1	Direct/1	Direct/1	Direct/1
CFM [L/s]	8000 [3775]	8000 [3775]	8000 [3775]	8000 [3775]
No. Motors/HP	2 at 1/2 HP	2 at 1/2 HP	2 at 1/2 HP	2 at 1/2 HP
Motor RPM	1075	1075	1075	1075
Indoor Fan - Type	FC Centrifugal	FC Centrifugal	FC Centrifugal	FC Centrifugal
No. Used/Diameter in. [mm]	1/15x15 [381x381]	1/15x15 [381x381]	1/15x15 [381x381]	1/15x15 [381x381]
Drive Type	Belt (Adjustable)	Belt (Adjustable)	Belt (Adjustable)	Belt (Adjustable)
No. Speeds	Dual	Dual	Dual	Dual
No. Motors	1	1	1	1
Motor HP	2	3	3	2
Motor RPM	1725	1725	1725	1725
Motor Frame Size	56	56	56	56
Filter - Type	Disposable	Disposable	Disposable	Disposable
Furnished	Yes	Yes	Yes	Yes
(NO.) Size Recommended in. [mm x mm x mm]	(4)2x20x20 [51x508x508]	(4)2x20x20 [51x508x508]	(4)2x20x20 [51x508x508]	(4)2x20x20 [51x508x508]
Refrigerant Charge Oz. [g]	197 [5585]	197 [5585]	197 [5585]	197 [5585]
Weights				
Net Weight lbs. [kg]	811 [368]	821 [372]	822 [373]	811 [368]
Ship Weight lbs. [kg]	850 [386]	860 [390]	861 [391]	850 [386]

### NOTES:

- Cooling Performance is rated at 95° F ambient, 80° F entering dry bulb, 67° F entering wet bulb. Gross capacity does not include the effect of fan motor heat. AHRI capacity is net and includes the effect of fan motor heat. Units are suitable for operation to ±20% of nominal cfm. Units are certified in accordance with the Unitary Air Conditioner Equipment certification program, which is based on AHRI Standard 210/240 or 360.
- EER and/or SEER are rated at AHRI conditions and in accordance with DOE test procedures.
- Integrated Part Load Value is rated in accordance with AHRI Standard 210/240 or 360. Units are rated at 80° F ambient, 80° F entering dry bulb, and 67° F entering wet bulb at AHRI rated cfm.
- Outdoor Sound Rating shown is tested in accordance with AHRI Standard 270.



## GENERAL DATA

Model -HPDZT Series	102AYG	102AYH	120ACF	120ACG
Cooling Performance <sup>1</sup>				Continued ->
Gross Cooling Capacity Btu [kW]	101,000 [29.59]	101,000 [29.59]	119,000 [34.87]	119,000 [34.87]
EER/SEER2	11/NA	11/NA	11/NA	11/NA
Nominal CFM/AHRI Rated CFM [L/s]	3400/3345 [1604/1579]	3400/3345 [1604/1579]	4000/4060 [1888/1916]	4000/4060 [1888/1916]
AHRI Net Cooling Capacity Btu [kW]	98,000 [28.71]	98,000 [28.71]	114,000 [33.4]	114,000 [33.4]
Net Sensible Capacity Btu [kW]	71,000 [20.8]	71,000 [20.8]	82,800 [24.26]	82,800 [24.26]
Net Latent Capacity Btu [kW]	27,000 [7.91]	27,000 [7.91]	31,200 [9.14]	31,200 [9.14]
IEER3	14.1	14.1	14.1	14.1
Net System Power kW	8.47	8.47	10.13	10.13
Heating Performance (Heat Pumps)				
High Temp. Btuh [kW] Rating	98,000 [28.71]	98,000 [28.71]	112,000 [32.8]	112,000 [32.8]
System Power KW / COP	7.99/3.4	7.99/3.4	9.03/3.4	9.03/3.4
Low Temp. Btuh [kW] Rating	60,000 [17.58]	60,000 [17.58]	68,000 [20.0]	68,000 [20.0]
System Power KW / COP	7.54/2.25	7.54/2.25	8.3/2.25	8.3/2.25
Compressor				
No./Type	1/Scroll	1/Scroll	1/Scroll	1/Scroll
Outdoor Sound Rating (dB)5	88	88	88	88
Outdoor Coil - Fin Type	Louvered	Louvered	Louvered	Louvered
Tube Type	MicroChannel	MicroChannel	MicroChannel	MicroChannel
MicroChannel Depth in. [mm]	1.26 [32]	1.26 [32]	1.26 [32]	1.26 [32]
Face Area sq. ft. [sq. m]	22.4 [2.08]	22.4 [2.08]	28.8 [2.68]	28.8 [2.68]
Rows / FPI [FPcm]	1 / 16 [6]	1 / 16 [6]	1 / 16 [6]	1 / 16 [6]
Refrigerant Control	TX Valves	TX Valves	TX Valves	TX Valves
Indoor Coil - Fin Type	Louvered	Louvered	Louvered	Louvered
Tube Type	MicroChannel	MicroChannel	MicroChannel	MicroChannel
MicroChannel Depth in. [mm]	1.26 [32]	1.26 [32]	1.26 [32]	1.26 [32]
Face Area sq. ft. [sq. m]	10.9 [1.01]	10.9 [1.01]	13.2 [1.23]	13.2 [1.23]
Rows / FPI [FPcm]	1 / 20 [8]	1 / 20 [8]	1 / 20 [8]	1 / 20 [8]
Refrigerant Control	TX Valves	TX Valves	TX Valves	TX Valves
Drain Connection No./Size in. [mm]	1/0.75 [19.05]	1/0.75 [19.05]	1/0.75 [19.05]	1/0.75 [19.05]
Outdoor Fan - Type	Propeller	Propeller	Propeller	Propeller
No. Used/Diameter in. [mm]	2/24 [609.6]	2/24 [609.6]	2/24 [609.6]	2/24 [609.6]
Drive Type/No. Speeds	Direct/1	Direct/1	Direct/1	Direct/1
CFM [L/s]	8000 [3775]	8000 [3775]	8000 [3775]	8000 [3775]
No. Motors/HP	2 at 1/2 HP	2 at 1/2 HP	2 at 1/2 HP	2 at 1/2 HP
Motor RPM	1075	1075	1075	1075
Indoor Fan - Type	FC Centrifugal	FC Centrifugal	FC Centrifugal	FC Centrifugal
No. Used/Diameter in. [mm]	1/15x15 [381x381]	1/15x15 [381x381]	1/15x15 [381x381]	1/15x15 [381x381]
Drive Type	Belt (Adjustable)	Belt (Adjustable)	Belt (Adjustable)	Belt (Adjustable)
No. Speeds	Dual	Dual	Dual	Dual
No. Motors	1	1	1	1
Motor HP	3	3	2	3
Motor RPM	1725	1725	1725	1725
Motor Frame Size	56	56	56	56
Filter - Type	Disposable	Disposable	Disposable	Disposable
Furnished	Yes	Yes	Yes	Yes
(NO.) Size Recommended in. [mm x mm x mm]	(4)2x20x20 [51x508x508]	(4)2x20x20 [51x508x508]	(4)2x25x20 [51x635x508]	(4)2x25x20 [51x635x508]
Refrigerant Charge Oz. [g]	197 [5585]	197 [5585]	214.4 [6078.14]	214.4 [6078.14]
Weights				
Net Weight lbs. [kg]	821 [372]	822 [373]	863 [391]	873 [396]
Ship Weight lbs. [kg]	860 [390]	861 [391]	902 [409]	912 [414]

### NOTES:

- Cooling Performance is rated at 95° F ambient, 80° F entering dry bulb, 67° F entering wet bulb. Gross capacity does not include the effect of fan motor heat. AHRI capacity is net and includes the effect of fan motor heat. Units are suitable for operation to ±20% of nominal cfm. Units are certified in accordance with the Unitary Air Conditioner Equipment certification program, which is based on AHRI Standard 210/240 or 360.
- EER and/or SEER are rated at AHRI conditions and in accordance with DOE test procedures.
- Integrated Part Load Value is rated in accordance with AHRI Standard 210/240 or 360. Units are rated at 80° F ambient, 80° F entering dry bulb, and 67° F entering wet bulb at AHRI rated cfm.
- Outdoor Sound Rating shown is tested in accordance with AHRI Standard 270.

## GENERAL DATA

Model -HPDZT Series	120ACH	120ADF	120ADG	120ADH
Cooling Performance <sup>1</sup>				Continued ->
Gross Cooling Capacity Btu [kW]	119,000 [34.87]	119,000 [34.87]	119,000 [34.87]	119,000 [34.87]
EER/SEER <sup>2</sup>	11/NA	11/NA	11/NA	11/NA
Nominal CFM/AHRI Rated CFM [L/s]	4000/4060 [1888/1916]	4000/4060 [1888/1916]	4000/4060 [1888/1916]	4000/4060 [1888/1916]
AHRI Net Cooling Capacity Btu [kW]	114,000 [33.4]	114,000 [33.4]	114,000 [33.4]	114,000 [33.4]
Net Sensible Capacity Btu [kW]	82,800 [24.26]	82,800 [24.26]	82,800 [24.26]	82,800 [24.26]
Net Latent Capacity Btu [kW]	31,200 [9.14]	31,200 [9.14]	31,200 [9.14]	31,200 [9.14]
IEER <sup>3</sup>	14.1	14.1	14.1	14.1
Net System Power kW	10.13	10.13	10.13	10.13
Heating Performance (Heat Pumps)				
High Temp. Btuh [kW] Rating	112,000 [32.8]	112,000 [32.8]	112,000 [32.8]	112,000 [32.8]
System Power KW / COP	9.03/3.4	9.03/3.4	9.03/3.4	9.03/3.4
Low Temp. Btuh [kW] Rating	68,000 [20.0]	68,000 [20.0]	68,000 [20.0]	68,000 [20.0]
System Power KW / COP	8.3/2.25	8.3/2.25	8.3/2.25	8.3/2.25
Compressor				
No./Type	1/Scroll	1/Scroll	1/Scroll	1/Scroll
Outdoor Sound Rating (dB) <sup>5</sup>	88	88	88	88
Outdoor Coil - Fin Type				
Tube Type	Louvered	Louvered	Louvered	Louvered
MicroChannel Depth in. [mm]	1.26 [32]	1.26 [32]	1.26 [32]	1.26 [32]
Face Area sq. ft. [sq. m]	28.8 [2.68]	28.8 [2.68]	28.8 [2.68]	28.8 [2.68]
Rows / FPI [FPcm]	1 / 16 [6]	1 / 16 [6]	1 / 16 [6]	1 / 16 [6]
Refrigerant Control	TX Valves	TX Valves	TX Valves	TX Valves
Indoor Coil - Fin Type				
Tube Type	Louvered	Louvered	Louvered	Louvered
MicroChannel Depth in. [mm]	1.26 [32]	1.26 [32]	1.26 [32]	1.26 [32]
Face Area sq. ft. [sq. m]	13.2 [1.23]	13.2 [1.23]	13.2 [1.23]	13.2 [1.23]
Rows / FPI [FPcm]	1 / 20 [8]	1 / 20 [8]	1 / 20 [8]	1 / 20 [8]
Refrigerant Control	TX Valves	TX Valves	TX Valves	TX Valves
Drain Connection No./Size in. [mm]	1/0.75 [19.05]	1/0.75 [19.05]	1/0.75 [19.05]	1/0.75 [19.05]
Outdoor Fan - Type				
No. Used/Diameter in. [mm]	2/24 [609.6]	2/24 [609.6]	2/24 [609.6]	2/24 [609.6]
Drive Type/No. Speeds	Direct/1	Direct/1	Direct/1	Direct/1
CFM [L/s]	8000 [3775]	8000 [3775]	8000 [3775]	8000 [3775]
No. Motors/HP	2 at 1/2 HP	2 at 1/2 HP	2 at 1/2 HP	2 at 1/2 HP
Motor RPM	1075	1075	1075	1075
Indoor Fan - Type				
No. Used/Diameter in. [mm]	1/15x15 [381x381]	1/15x15 [381x381]	1/15x15 [381x381]	1/15x15 [381x381]
Drive Type	Belt (Adjustable)	Belt (Adjustable)	Belt (Adjustable)	Belt (Adjustable)
No. Speeds	Dual	Dual	Dual	Dual
No. Motors	1	1	1	1
Motor HP	3	2	3	3
Motor RPM	1725	1725	1725	1725
Motor Frame Size	56	56	56	56
Filter - Type				
Furnished	Yes	Yes	Yes	Yes
(NO.) Size Recommended in. [mm x mm x mm]	(4)2x25x20 [51x635x508]	(4)2x25x20 [51x635x508]	(4)2x25x20 [51x635x508]	(4)2x25x20 [51x635x508]
Refrigerant Charge Oz. [g]	214.4 [6078.14]	214.4 [6078.14]	214.4 [6078.14]	214.4 [6078.14]
Weights				
Net Weight lbs. [kg]	874 [396]	863 [391]	873 [396]	874 [396]
Ship Weight lbs. [kg]	913 [414]	902 [409]	912 [414]	913 [414]

### NOTES:

- Cooling Performance is rated at 95° F ambient, 80° F entering dry bulb, 67° F entering wet bulb. Gross capacity does not include the effect of fan motor heat. AHRI capacity is net and includes the effect of fan motor heat. Units are suitable for operation to ±20% of nominal cfm. Units are certified in accordance with the Unitary Air Conditioner Equipment certification program, which is based on AHRI Standard 210/240 or 360.
- EER and/or SEER are rated at AHRI conditions and in accordance with DOE test procedures.
- Integrated Part Load Value is rated in accordance with AHRI Standard 210/240 or 360. Units are rated at 80° F ambient, 80° F entering dry bulb, and 67° F entering wet bulb at AHRI rated cfm.
- Outdoor Sound Rating shown is tested in accordance with AHRI Standard 270.



## GENERAL DATA

Model -HPDZT Series	120AYF	120AYG	120AYH
<b>Cooling Performance<sup>1</sup></b>			
Gross Cooling Capacity Btu [kW]	119,000 [34.87]	119,000 [34.87]	119,000 [34.87]
EER/SEER <sup>2</sup>	11/NA	11/NA	11/NA
Nominal CFM/AHRI Rated CFM [L/s]	4000/4060 [1888/1916]	4000/4060 [1888/1916]	4000/4060 [1888/1916]
AHRI Net Cooling Capacity Btu [kW]	114,000 [33.4]	114,000 [33.4]	114,000 [33.4]
Net Sensible Capacity Btu [kW]	82,800 [24.26]	82,800 [24.26]	82,800 [24.26]
Net Latent Capacity Btu [kW]	31,200 [9.14]	31,200 [9.14]	31,200 [9.14]
IEER <sup>3</sup>	14.1	14.1	14.1
Net System Power kW	10.13	10.13	10.13
<b>Heating Performance (Heat Pumps)</b>			
High Temp. Btuh [kW] Rating	112,000 [32.8]	112,000 [32.8]	112,000 [32.8]
System Power KW / COP	9.03/3.4	9.03/3.4	9.03/3.4
Low Temp. Btuh [kW] Rating	68,000 [20.0]	68,000 [20.0]	68,000 [20.0]
System Power KW / COP	8.3/2.25	8.3/2.25	8.3/2.25
<b>Compressor</b>			
No./Type	1/Scroll	1/Scroll	1/Scroll
<b>Outdoor Sound Rating (dB)<sup>5</sup></b>			
	88	88	88
<b>Outdoor Coil - Fin Type</b>			
Tube Type	Louvered	Louvered	Louvered
MicroChannel Depth in. [mm]	1.26 [32]	1.26 [32]	1.26 [32]
Face Area sq. ft. [sq. m]	28.8 [2.68]	28.8 [2.68]	28.8 [2.68]
Rows / FPI [FPcm]	1 / 16 [6]	1 / 16 [6]	1 / 16 [6]
Refrigerant Control	TX Valves	TX Valves	TX Valves
<b>Indoor Coil - Fin Type</b>			
Tube Type	Louvered	Louvered	Louvered
MicroChannel Depth in. [mm]	1.26 [32]	1.26 [32]	1.26 [32]
Face Area sq. ft. [sq. m]	13.2 [1.23]	13.2 [1.23]	13.2 [1.23]
Rows / FPI [FPcm]	1 / 20 [8]	1 / 20 [8]	1 / 20 [8]
Refrigerant Control	TX Valves	TX Valves	TX Valves
Drain Connection No./Size in. [mm]	1/0.75 [19.05]	1/0.75 [19.05]	1/0.75 [19.05]
<b>Outdoor Fan - Type</b>			
No. Used/Diameter in. [mm]	2/24 [609.6]	2/24 [609.6]	2/24 [609.6]
Drive Type/No. Speeds	Direct/1	Direct/1	Direct/1
CFM [L/s]	8000 [3775]	8000 [3775]	8000 [3775]
No. Motors/HP	2 at 1/2 HP	2 at 1/2 HP	2 at 1/2 HP
Motor RPM	1075	1075	1075
<b>Indoor Fan - Type</b>			
No. Used/Diameter in. [mm]	1/15x15 [381x381]	1/15x15 [381x381]	1/15x15 [381x381]
Drive Type	Belt (Adjustable)	Belt (Adjustable)	Belt (Adjustable)
No. Speeds	Dual	Dual	Dual
No. Motors	1	1	1
Motor HP	2	3	3
Motor RPM	1725	1725	1725
Motor Frame Size	56	56	56
<b>Filter - Type</b>			
Furnished	Yes	Yes	Yes
(NO.) Size Recommended in. [mm x mm x mm]	(4)2x25x20 [51x635x508]	(4)2x25x20 [51x635x508]	(4)2x25x20 [51x635x508]
<b>Refrigerant Charge Oz. [g]</b>			
	214.4 [6078.14]	214.4 [6078.14]	214.4 [6078.14]
<b>Weights</b>			
Net Weight lbs. [kg]	863 [391]	873 [396]	874 [396]
Ship Weight lbs. [kg]	902 [409]	912 [414]	913 [414]

### NOTES:

- Cooling Performance is rated at 95° F ambient, 80° F entering dry bulb, 67° F entering wet bulb. Gross capacity does not include the effect of fan motor heat. AHRI capacity is net and includes the effect of fan motor heat. Units are suitable for operation to ±20% of nominal cfm. Units are certified in accordance with the Unitary Air Conditioner Equipment certification program, which is based on AHRI Standard 210/240 or 360.
- EER and/or SEER are rated at AHRI conditions and in accordance with DOE test procedures.
- Integrated Part Load Value is rated in accordance with AHRI Standard 210/240 or 360. Units are rated at 80° F ambient, 80° F entering dry bulb, and 67° F entering wet bulb at AHRI rated cfm.
- Outdoor Sound Rating shown is tested in accordance with AHRI Standard 270.

**ELECTRICAL DATA - HPDZR SERIES**

		090ACA	090ACB	090ACC	090ADA	090ADB	090ADC	090AYA	090AYB	090AYC
<b>Unit Information</b>	Unit Operating Voltage Range	187-253	187-253	187-253	414-506	414-506	414-506	517-632	517-632	517-632
	Volts	208/230	208/230	208/230	460	460	460	575	575	575
	Phase	3	3	3	3	3	3	3	3	3
	Hz	60	60	60	60	60	60	60	60	60
	Minimum Circuit Ampacity	43	46	46	23	24	24	17	18	18
	Minimum Overcurrent Protection Device Size	50	60	60	30	30	30	20	25	25
	Maximum Overcurrent Protection Device Size	60	70	70	35	35	35	25	25	25
<b>Compressor Motor</b>	No.	1	1	1	1	1	1	1	1	1
	Volts	200/230	200/230	200/230	460	460	460	575	575	575
	Phase	3	3	3	3	3	3	3	3	3
	RPM	3450	3450	3450	3450	3450	3450	3450	3450	3450
	HP, Compressor 1	7	7	7	7	7	7	7	7	7
	Amps (RLA), Comp. 1	25	25	25	12.8	12.8	12.8	9.6	9.6	9.6
	Amps (LRA), Comp. 1	164	164	164	100	100	100	78	78	78
	HP, Compressor 2									
	Amps (RLA), Comp. 2									
Amps (LRA), Comp. 2										
<b>Condenser Motor</b>	No.	2	2	2	2	2	2	2	2	2
	Volts	208/230	208/230	208/230	460	460	460	575	575	575
	Phase	1	1	1	1	1	1	1	1	1
	HP	1/2	1/2	1/2	1/2	1/2	1/2	1/2	1/2	1/2
	Amps (FLA, each)	2.5	2.5	2.5	1.5	1.5	1.5	1.1	1.1	1.1
	Amps (LRA, each)	5.6	5.6	5.6	3.1	3.1	3.1	1.5	1.5	1.5
<b>Evaporator Fan</b>	No.	1	1	1	1	1	1	1	1	1
	Volts	208/230	208/230	208/230	460	460	460	575	575	575
	Phase	3	3	3	3	3	3	3	3	3
	HP	2	3	3	2	3	3	2	3	3
	Amps (FLA, each)	6.6	9.1	9.1	3.2	4.6	4.6	2.5	3.5	3.5
	Amps (LRA, each)	45	74.5	74.5	45	38.1	38.1	19	20	20

**ELECTRICAL DATA - HPDZR SERIES**

		102ACA	102ACB	102ACC	102ADA	102ADB	102ADC	102AYA	102AYB	102AYC
Unit Information	Unit Operating Voltage Range	187-253	187-253	187-253	414-506	414-506	414-506	517-632	517-632	517-632
	Volts	208/230	208/230	208/230	460	460	460	575	575	575
	Phase	3	3	3	3	3	3	3	3	3
	Hz	60	60	60	60	60	60	60	60	60
	Minimum Circuit Ampacity	47	49	52	23	24	25	17	18	18
	Minimum Overcurrent Protection Device Size	60	60	60	30	30	30	20	25	25
	Maximum Overcurrent Protection Device Size	70	70	70	35	35	35	25	25	25
Compressor Motor	No.	1	1	1	1	1	1	1	1	1
	Volts	200/230	200/230	200/230	460	460	460	575	575	575
	Phase	3	3	3	3	3	3	3	3	3
	RPM	3450	3450	3450	3450	3450	3450	3450	3450	3450
	HP, Compressor 1	7 1/2	7 1/2	7 1/2	7 1/2	7 1/2	7 1/2	7 1/2	7 1/2	7 1/2
	Amps (RLA), Comp. 1	27.6	27.6	27.6	12.8	12.8	12.8	9.6	9.6	9.6
	Amps (LRA), Comp. 1	191	191	191	100	100	100	78	78	78
	HP, Compressor 2									
	Amps (RLA), Comp. 2									
	Amps (LRA), Comp. 2									
Condenser Motor	No.	2	2	2	2	2	2	2	2	2
	Volts	208/230	208/230	208/230	460	460	460	575	575	575
	Phase	1	1	1	1	1	1	1	1	1
	HP	1/2	1/2	1/2	1/2	1/2	1/2	1/2	1/2	1/2
	Amps (FLA, each)	2.5	2.5	2.5	1.5	1.5	1.5	1.1	1.1	1.1
	Amps (LRA, each)	5.6	5.6	5.6	3.1	3.1	3.1	1.5	1.5	1.5
Evaporator Fan	No.	1	1	1	1	1	1	1	1	1
	Volts	208/230	208/230	208/230	460	460	460	575	575	575
	Phase	3	3	3	3	3	3	3	3	3
	HP	2	3	3	2	3	3	2	3	3
	Amps (FLA, each)	7	8.9	12	3.5	4.4	6	2.5	3.5	3.5
	Amps (LRA, each)	45	74.5	74.5	22.5	38.1	38.1	19	20	20

**ELECTRICAL DATA - HPDZR SERIES**

		120ACA	120ACB	120ACC	120ADA	120ADB	120ADC	120AYA	120AYB	120AYC
Unit Information	Unit Operating Voltage Range	187-253	187-253	187-253	414-506	414-506	414-506	517-632	517-632	517-632
	Volts	208/230	208/230	208/230	460	460	460	575	575	575
	Phase	3	3	3	3	3	3	3	3	3
	Hz	60	60	60	60	60	60	60	60	60
	Minimum Circuit Ampacity	48	51	53	26	27	28	19	20	20
	Minimum Overcurrent Protection Device Size	60	60	60	30	35	35	25	25	25
	Maximum Overcurrent Protection Device Size	70	70	80	40	40	40	30	30	30
Compressor Motor	No.	1	1	1	1	1	1	1	1	1
	Volts	200/230	200/230	200/230	460	460	460	575	575	575
	Phase	3	3	3	3	3	3	3	3	3
	RPM	3450	3450	3450	3450	3450	3450	3450	3450	3450
	HP, Compressor 1	10	10	10	10	10	10	10	10	10
	Amps (RLA), Comp. 1	28.2	28.2	28.2	14.7	14.7	14.7	11.3	11.3	11.3
	Amps (LRA), Comp. 1	239	239	239	130	130	130	93.7	93.7	93.7
	HP, Compressor 2									
	Amps (RLA), Comp. 2									
Amps (LRA), Comp. 2										
Condenser Motor	No.	2	2	2	2	2	2	2	2	2
	Volts	208/230	208/230	208/230	460	460	460	575	575	575
	Phase	1	1	1	1	1	1	1	1	1
	HP	1/2	1/2	1/2	1/2	1/2	1/2	1/2	1/2	1/2
	Amps (FLA, each)	2.5	2.5	2.5	1.5	1.5	1.5	1.1	1.1	1.1
	Amps (LRA, each)	5.6	5.6	5.6	3.1	3.1	3.1	1.5	1.5	1.5
Evaporator Fan	No.	1	1	1	1	1	1	1	1	1
	Volts	208/230	208/230	208/230	460	460	460	575	575	575
	Phase	3	3	3	3	3	3	3	3	3
	HP	2	3	3	2	3	3	2	3	3
	Amps (FLA, each)	7.7	10.4	12	3.9	5.2	6	2.5	3.5	3.5
	Amps (LRA, each)	45	74.5	74.5	23.5	38.1	38.1	19	20	20

**ELECTRICAL DATA - HPDZS SERIES**

		090ACA	090ACB	090ACC	090ACF	090ACG	090ACH	090ADA	090ADB	090ADC
Unit Information	Unit Operating Voltage Range	187-253	187-253	187-253	187-253	187-253	187-253	414-506	414-506	414-506
	Volts	208/230	208/230	208/230	208/230	208/230	208/230	460	460	460
	Phase	3	3	3	3	3	3	3	3	3
	Hz	60	60	60	60	60	60	60	60	60
	Minimum Circuit Ampacity	44	46	46	44	46	46	19	20	20
	Minimum Overcurrent Protection Device Size	50	60	60	50	60	60	25	25	25
	Maximum Overcurrent Protection Device Size	60	70	70	60	70	70	25	25	25
Compressor Motor	No.	1	1	1	1	1	1	1	1	1
	Volts	200/230	200/230	200/230	200/230	200/230	200/230	460	460	460
	Phase	3	3	3	3	3	3	3	3	3
	RPM	3450	3450	3450	3450	3450	3450	3450	3450	3450
	HP, Compressor 1	7	7	7	7	7	7	7	7	7
	Amps (RLA), Comp. 1	25.3	25.3	25.3	25.3	25.3	25.3	9.6	9.6	9.6
	Amps (LRA), Comp. 1	184	184	184	184	184	184	84	84	84
	HP, Compressor 2									
	Amps (RLA), Comp. 2									
	Amps (LRA), Comp. 2									
Condenser Motor	No.	2	2	2	2	2	2	2	2	2
	Volts	208/230	208/230	208/230	208/230	208/230	208/230	460	460	460
	Phase	1	1	1	1	1	1	1	1	1
	HP	1/2	1/2	1/2	1/2	1/2	1/2	1/2	1/2	1/2
	Amps (FLA, each)	2.5	2.5	2.5	2.5	2.5	2.5	1.5	1.5	1.5
	Amps (LRA, each)	5.6	5.6	5.6	5.6	5.6	5.6	3.1	3.1	3.1
Evaporator Fan	No.	1	1	1	1	1	1	1	1	1
	Volts	208/230	208/230	208/230	208/230	208/230	208/230	460	460	460
	Phase	3	3	3	3	3	3	3	3	3
	HP	2	3	3	2	3	3	2	3	3
	Amps (FLA, each)	6.6	9.1	9.1	6.6	9.1	9.1	3.2	4.6	4.6
	Amps (LRA, each)	45	74.5	74.5	45	74.5	74.5	45	38.1	38.1

**ELECTRICAL DATA - HPDZS SERIES**

		090ADF	090ADG	090ADH	090AYA	090AYB	090AYC	090AYF	090AYG	090AYH
Unit Information	Unit Operating Voltage Range	414-506	414-506	414-506	517-632	517-632	517-632	517-632	517-632	517-632
	Volts	460	460	460	575	575	575	575	575	575
	Phase	3	3	3	3	3	3	3	3	3
	Hz	60	60	60	60	60	60	60	60	60
	Minimum Circuit Ampacity	19	20	20	14	15	15	14	15	15
	Minimum Overcurrent Protection Device Size	25	25	25	20	20	20	20	20	20
	Maximum Overcurrent Protection Device Size	25	25	25	20	20	20	20	20	20
Compressor Motor	No.	1	1	1	1	1	1	1	1	1
	Volts	460	460	460	575	575	575	575	575	575
	Phase	3	3	3	3	3	3	3	3	3
	RPM	3450	3450	3450	3450	3450	3450	3450	3450	3450
	HP, Compressor 1	7	7	7	7	7	7	7	7	7
	Amps (RLA), Comp. 1	9.6	9.6	9.6	7.1	7.1	7.1	7.1	7.1	7.1
	Amps (LRA), Comp. 1	84	84	84	60	60	60	60	60	60
	HP, Compressor 2									
	Amps (RLA), Comp. 2									
	Amps (LRA), Comp. 2									
Condenser Motor	No.	2	2	2	2	2	2	2	2	2
	Volts	460	460	460	575	575	575	575	575	575
	Phase	1	1	1	1	1	1	1	1	1
	HP	1/2	1/2	1/2	1/2	1/2	1/2	1/2	1/2	1/2
	Amps (FLA, each)	1.5	1.5	1.5	1.1	1.1	1.1	1.1	1.1	1.1
	Amps (LRA, each)	3.1	3.1	3.1	1.5	1.5	1.5	1.5	1.5	1.5
Evaporator Fan	No.	1	1	1	1	1	1	1	1	1
	Volts	460	460	460	575	575	575	575	575	575
	Phase	3	3	3	3	3	3	3	3	3
	HP	2	3	3	2	3	3	2	3	3
	Amps (FLA, each)	3.2	4.6	4.6	2.5	3.5	3.5	2.5	3.5	3.5
	Amps (LRA, each)	45	38.1	38.1	19	20	20	19	20	20



**ELECTRICAL DATA - HPDZS SERIES**

		102ACA	102ACB	102ACC	102ACF	102ACG	102ACH	102ADA	102ADB	102ADC
Unit Information	Unit Operating Voltage Range	187-253	187-253	187-253	187-253	187-253	187-253	414-506	414-506	414-506
	Volts	208/230	208/230	208/230	208/230	208/230	208/230	460	460	460
	Phase	3	3	3	3	3	3	3	3	3
	Hz	60	60	60	60	60	60	60	60	60
	Minimum Circuit Ampacity	48	50	53	48	50	53	23	24	25
	Minimum Overcurrent Protection Device Size	60	60	70	60	60	70	30	30	30
	Maximum Overcurrent Protection Device Size	70	70	80	70	70	80	30	35	35
Compressor Motor	No.	1	1	1	1	1	1	1	1	1
	Volts	200/230	200/230	200/230	200/230	200/230	200/230	460	460	460
	Phase	3	3	3	3	3	3	3	3	3
	RPM	3450	3450	3450	3450	3450	3450	3450	3450	3450
	HP, Compressor 1	7 1/2	7 1/2	7 1/2	7 1/2	7 1/2	7 1/2	7 1/2	7 1/2	7 1/2
	Amps (RLA), Comp. 1	28.8	28.8	28.8	28.8	28.8	28.8	12.5	12.5	12.5
	Amps (LRA), Comp. 1	191	191	191	191	191	191	100	100	100
	HP, Compressor 2									
	Amps (RLA), Comp. 2									
	Amps (LRA), Comp. 2									
Condenser Motor	No.	2	2	2	2	2	2	2	2	2
	Volts	208/230	208/230	208/230	208/230	208/230	208/230	460	460	460
	Phase	1	1	1	1	1	1	1	1	1
	HP	1/2	1/2	1/2	1/2	1/2	1/2	1/2	1/2	1/2
	Amps (FLA, each)	2.5	2.5	2.5	2.5	2.5	2.5	1.5	1.5	1.5
	Amps (LRA, each)	5.6	5.6	5.6	5.6	5.6	5.6	3.1	3.1	3.1
Evaporator Fan	No.	1	1	1	1	1	1	1	1	1
	Volts	208/230	208/230	208/230	208/230	208/230	208/230	460	460	460
	Phase	3	3	3	3	3	3	3	3	3
	HP	2	3	3	2	3	3	2	3	3
	Amps (FLA, each)	7	8.9	12	7	8.9	12	3.5	4.4	6
	Amps (LRA, each)	45	74.5	74.5	45	74.5	74.5	22.5	38.1	38.1

**ELECTRICAL DATA - HPDZS SERIES**

		102ADF	102ADG	102ADH	102AYA	102AYB	102AYC	102AYF	102AYG	102AYH
<b>Unit Information</b>	Unit Operating Voltage Range	414-506	414-506	414-506	517-632	517-632	517-632	517-632	517-632	517-632
	Volts	460	460	460	575	575	575	575	575	575
	Phase	3	3	3	3	3	3	3	3	3
	Hz	60	60	60	60	60	60	60	60	60
	Minimum Circuit Ampacity	23	24	25	17	18	18	17	18	18
	Minimum Overcurrent Protection Device Size	30	30	30	20	25	25	20	25	25
	Maximum Overcurrent Protection Device Size	30	35	35	25	25	25	25	25	25
<b>Compressor Motor</b>	No.	1	1	1	1	1	1	1	1	1
	Volts	460	460	460	575	575	575	575	575	575
	Phase	3	3	3	3	3	3	3	3	3
	RPM	3450	3450	3450	3450	3450	3450	3450	3450	3450
	HP, Compressor 1	7 1/2	7 1/2	7 1/2	7 1/2	7 1/2	7 1/2	7 1/2	7 1/2	7 1/2
	Amps (RLA), Comp. 1	12.5	12.5	12.5	9.7	9.7	9.7	9.7	9.7	9.7
	Amps (LRA), Comp. 1	100	100	100	70	70	70	70	70	70
	HP, Compressor 2									
	Amps (RLA), Comp. 2									
	Amps (LRA), Comp. 2									
<b>Condenser Motor</b>	No.	2	2	2	2	2	2	2	2	2
	Volts	460	460	460	575	575	575	575	575	575
	Phase	1	1	1	1	1	1	1	1	1
	HP	1/2	1/2	1/2	1/2	1/2	1/2	1/2	1/2	1/2
	Amps (FLA, each)	1.5	1.5	1.5	1.1	1.1	1.1	1.1	1.1	1.1
	Amps (LRA, each)	3.1	3.1	3.1	1.5	1.5	1.5	1.5	1.5	1.5
<b>Evaporator Fan</b>	No.	1	1	1	1	1	1	1	1	1
	Volts	460	460	460	575	575	575	575	575	575
	Phase	3	3	3	3	3	3	3	3	3
	HP	2	3	3	2	3	3	2	3	3
	Amps (FLA, each)	3.5	4.4	6	2.5	3.5	3.5	2.5	3.5	3.5
	Amps (LRA, each)	22.5	38.1	38.1	19	20	20	19	20	20

**ELECTRICAL DATA - HPDZS SERIES**

		120ACA	120ACB	120ACC	120ACF	120ACG	120ACH	120ADA	120ADB	120ADC
Unit Information	Unit Operating Voltage Range	187-253	187-253	187-253	187-253	187-253	187-253	414-506	414-506	414-506
	Volts	208/230	208/230	208/230	208/230	208/230	208/230	460	460	460
	Phase	3	3	3	3	3	3	3	3	3
	Hz	60	60	60	60	60	60	60	60	60
	Minimum Circuit Ampacity	54	57	58	54	57	58	26	27	28
	Minimum Overcurrent Protection Device Size	70	70	70	70	70	70	30	35	35
	Maximum Overcurrent Protection Device Size	80	80	90	80	80	90	40	40	40
Compressor Motor	No.	1	1	1	1	1	1	1	1	1
	Volts	200/230	200/230	200/230	200/230	200/230	200/230	460	460	460
	Phase	3	3	3	3	3	3	3	3	3
	RPM	3450	3450	3450	3450	3450	3450	3450	3450	3450
	HP, Compressor 1	10	10	10	10	10	10	10	10	10
	Amps (RLA), Comp. 1	32.6	32.6	32.6	32.6	32.6	32.6	14.8	14.8	14.8
	Amps (LRA), Comp. 1	240	240	240	240	240	240	130	130	130
	HP, Compressor 2									
	Amps (RLA), Comp. 2									
	Amps (LRA), Comp. 2									
Condenser Motor	No.	2	2	2	2	2	2	2	2	2
	Volts	208/230	208/230	208/230	208/230	208/230	208/230	460	460	460
	Phase	1	1	1	1	1	1	1	1	1
	HP	1/2	1/2	1/2	1/2	1/2	1/2	1/2	1/2	1/2
	Amps (FLA, each)	2.5	2.5	2.5	2.5	2.5	2.5	1.5	1.5	1.5
	Amps (LRA, each)	5.6	5.6	5.6	5.6	5.6	5.6	3.1	3.1	3.1
Evaporator Fan	No.	1	1	1	1	1	1	1	1	1
	Volts	208/230	208/230	208/230	208/230	208/230	208/230	460	460	460
	Phase	3	3	3	3	3	3	3	3	3
	HP	2	3	3	2	3	3	2	3	3
	Amps (FLA, each)	7.7	10.4	12	7.7	10.4	12	3.9	5.2	6
	Amps (LRA, each)	45	74.5	74.5	45	74.5	74.5	23.5	38.1	38.1

**ELECTRICAL DATA - HPDZS SERIES**

		120ADF	120ADG	120ADH	120AYA	120AYB	120AYC	120AYF	120AYG	120AYH
Unit Information	Unit Operating Voltage Range	414-506	414-506	414-506	517-632	517-632	517-632	517-632	517-632	517-632
	Volts	460	460	460	575	575	575	575	575	575
	Phase	3	3	3	3	3	3	3	3	3
	Hz	60	60	60	60	60	60	60	60	60
	Minimum Circuit Ampacity	26	27	28	19	20	20	19	20	20
	Minimum Overcurrent Protection Device Size	30	35	35	25	25	25	25	25	25
	Maximum Overcurrent Protection Device Size	40	40	40	25	30	30	25	30	30
Compressor Motor	No.	1	1	1	1	1	1	1	1	1
	Volts	460	460	460	575	575	575	575	575	575
	Phase	3	3	3	3	3	3	3	3	3
	RPM	3450	3450	3450	3450	3450	3450	3450	3450	3450
	HP, Compressor 1	10	10	10	10	10	10	10	10	10
	Amps (RLA), Comp. 1	14.8	14.8	14.8	11.1	11.1	11.1	11.1	11.1	11.1
	Amps (LRA), Comp. 1	130	130	130	93.7	93.7	93.7	93.7	93.7	93.7
	HP, Compressor 2									
	Amps (RLA), Comp. 2									
	Amps (LRA), Comp. 2									
Condenser Motor	No.	2	2	2	2	2	2	2	2	2
	Volts	460	460	460	575	575	575	575	575	575
	Phase	1	1	1	1	1	1	1	1	1
	HP	1/2	1/2	1/2	1/2	1/2	1/2	1/2	1/2	1/2
	Amps (FLA, each)	1.5	1.5	1.5	1.1	1.1	1.1	1.1	1.1	1.1
	Amps (LRA, each)	3.1	3.1	3.1	1.5	1.5	1.5	1.5	1.5	1.5
Evaporator Fan	No.	1	1	1	1	1	1	1	1	1
	Volts	460	460	460	575	575	575	575	575	575
	Phase	3	3	3	3	3	3	3	3	3
	HP	2	3	3	2	3	3	2	3	3
	Amps (FLA, each)	3.9	5.2	6	2.5	3.5	3.5	2.5	3.5	3.5
	Amps (LRA, each)	23.5	38.1	38.1	19	20	20	19	20	20

**ELECTRICAL DATA - HPDZT SERIES**

		090ACF	090ACG	090ACH	090ADF	090ADG	090ADH	090AYF	090AYG	090AYH
Unit Information	Unit Operating Voltage Range	187-253	187-253	187-253	414-506	414-506	414-506	517-632	517-632	517-632
	Volts	208/230	208/230	208/230	460	460	460	575	575	575
	Phase	3	3	3	3	3	3	3	3	3
	Hz	60	60	60	60	60	60	60	60	60
	Minimum Circuit Ampacity	44	46	46	19	20	20	14	15	15
	Minimum Overcurrent Protection Device Size	50	60	60	25	25	25	20	20	20
	Maximum Overcurrent Protection Device Size	60	70	70	25	25	25	20	20	20
Compressor Motor	No.	1	1	1	1	1	1	1	1	1
	Volts	200/230	200/230	200/230	460	460	460	575	575	575
	Phase	3	3	3	3	3	3	3	3	3
	RPM	3450	3450	3450	3450	3450	3450	3450	3450	3450
	HP, Compressor 1	7	7	7	7	7	7	7	7	7
	Amps (RLA), Comp. 1	25.3	25.3	25.3	9.6	9.6	9.6	7.1	7.1	7.1
	Amps (LRA), Comp. 1	184	184	184	84	84	84	60	60	60
	HP, Compressor 2									
	Amps (RLA), Comp. 2									
	Amps (LRA), Comp. 2									
Condenser Motor	No.	2	2	2	2	2	2	2	2	2
	Volts	208/230	208/230	208/230	460	460	460	575	575	575
	Phase	1	1	1	1	1	1	1	1	1
	HP	1/2	1/2	1/2	1/2	1/2	1/2	1/2	1/2	1/2
	Amps (FLA, each)	2.5	2.5	2.5	1.5	1.5	1.5	1.1	1.1	1.1
	Amps (LRA, each)	5.6	5.6	5.6	3.1	3.1	3.1	1.5	1.5	1.5
Evaporator Fan	No.	1	1	1	1	1	1	1	1	1
	Volts	208/230	208/230	208/230	460	460	460	575	575	575
	Phase	3	3	3	3	3	3	3	3	3
	HP	2	3	3	2	3	3	2	3	3
	Amps (FLA, each)	6.6	9.1	9.1	3.2	4.6	4.6	2.5	3.5	3.5
	Amps (LRA, each)	45	74.5	74.5	45	38.1	38.1	19	20	20

**ELECTRICAL DATA - HPDZT SERIES**

		102ACF	102ACG	102ACH	102ADF	102ADG	102ADH	102AYF	102AYG	102AYH
<b>Unit Information</b>	Unit Operating Voltage Range	187-253	187-253	187-253	414-506	414-506	414-506	517-632	517-632	517-632
	Volts	208/230	208/230	208/230	460	460	460	575	575	575
	Phase	3	3	3	3	3	3	3	3	3
	Hz	60	60	60	60	60	60	60	60	60
	Minimum Circuit Ampacity	48	50	53	23	24	25	17	18	18
	Minimum Overcurrent Protection Device Size	60	60	70	30	30	30	20	25	25
	Maximum Overcurrent Protection Device Size	70	70	80	30	35	35	25	25	25
<b>Compressor Motor</b>	No.	1	1	1	1	1	1	1	1	1
	Volts	200/230	200/230	200/230	460	460	460	575	575	575
	Phase	3	3	3	3	3	3	3	3	3
	RPM	3450	3450	3450	3450	3450	3450	3450	3450	3450
	HP, Compressor 1	7 1/2	7 1/2	7 1/2	7 1/2	7 1/2	7 1/2	7 1/2	7 1/2	7 1/2
	Amps (RLA), Comp. 1	28.8	28.8	28.8	12.5	12.5	12.5	9.7	9.7	9.7
	Amps (LRA), Comp. 1	191	191	191	100	100	100	70	70	70
	HP, Compressor 2									
	Amps (RLA), Comp. 2									
Amps (LRA), Comp. 2										
<b>Condenser Motor</b>	No.	2	2	2	2	2	2	2	2	2
	Volts	208/230	208/230	208/230	460	460	460	575	575	575
	Phase	1	1	1	1	1	1	1	1	1
	HP	1/2	1/2	1/2	1/2	1/2	1/2	1/2	1/2	1/2
	Amps (FLA, each)	2.5	2.5	2.5	1.5	1.5	1.5	1.1	1.1	1.1
	Amps (LRA, each)	5.6	5.6	5.6	3.1	3.1	3.1	1.5	1.5	1.5
<b>Evaporator Fan</b>	No.	1	1	1	1	1	1	1	1	1
	Volts	208/230	208/230	208/230	460	460	460	575	575	575
	Phase	3	3	3	3	3	3	3	3	3
	HP	2	3	3	2	3	3	2	3	3
	Amps (FLA, each)	7	8.9	12	3.5	4.4	6	2.5	3.5	3.5
	Amps (LRA, each)	45	74.5	74.5	22.5	38.1	38.1	19	20	20



**ELECTRICAL DATA - HPDZT SERIES**

		120ACF	120ACG	120ACH	120ADF	120ADG	120ADH	120AYF	120AYG	120AYH
<b>Unit Information</b>	Unit Operating Voltage Range	187-253	187-253	187-253	414-506	414-506	414-506	517-632	517-632	517-632
	Volts	208/230	208/230	208/230	460	460	460	575	575	575
	Phase	3	3	3	3	3	3	3	3	3
	Hz	60	60	60	60	60	60	60	60	60
	Minimum Circuit Ampacity	54	57	58	26	27	28	19	20	20
	Minimum Overcurrent Protection Device Size	70	70	70	30	35	35	25	25	25
	Maximum Overcurrent Protection Device Size	80	80	90	40	40	40	25	30	30
<b>Compressor Motor</b>	No.	1	1	1	1	1	1	1	1	1
	Volts	200/230	200/230	200/230	460	460	460	575	575	575
	Phase	3	3	3	3	3	3	3	3	3
	RPM	3450	3450	3450	3450	3450	3450	3450	3450	3450
	HP, Compressor 1	10	10	10	10	10	10	10	10	10
	Amps (RLA), Comp. 1	32.6	32.6	32.6	14.8	14.8	14.8	11.1	11.1	11.1
	Amps (LRA), Comp. 1	240	240	240	130	130	130	93.7	93.7	93.7
	HP, Compressor 2									
	Amps (RLA), Comp. 2									
	Amps (LRA), Comp. 2									
<b>Condenser Motor</b>	No.	2	2	2	2	2	2	2	2	2
	Volts	208/230	208/230	208/230	460	460	460	575	575	575
	Phase	1	1	1	1	1	1	1	1	1
	HP	1/2	1/2	1/2	1/2	1/2	1/2	1/2	1/2	1/2
	Amps (FLA, each)	2.5	2.5	2.5	1.5	1.5	1.5	1.1	1.1	1.1
	Amps (LRA, each)	5.6	5.6	5.6	3.1	3.1	3.1	1.5	1.5	1.5
<b>Evaporator Fan</b>	No.	1	1	1	1	1	1	1	1	1
	Volts	208/230	208/230	208/230	460	460	460	575	575	575
	Phase	3	3	3	3	3	3	3	3	3
	HP	2	3	3	2	3	3	2	3	3
	Amps (FLA, each)	7.7	10.4	12	3.9	5.2	6	2.5	3.5	3.5
	Amps (LRA, each)	45	74.5	74.5	23.5	38.1	38.1	19	20	20

## VI. INSTALLATION

### A. GENERAL

#### 1. PRE-INSTALLATION CHECK-POINTS

Before attempting any installation, the following points should be carefully considered:

- Structural strength of supporting members. (rooftop installation)
- Clearances and provision for servicing.
- Power supply and wiring.
- Air duct connections.
- Drain facilities and connections.
- Location for minimum noise.

#### 2. LOCATION

These units are designed for outdoor installations. They can be mounted on a slab or rooftop. They are not to be installed within any part of a structure such as an attic, crawl space, closet, or any other place where condenser air flow is restricted or other than outdoor ambient conditions prevail. Since the application of the units is of the outdoor type, it is important to consult your local code authorities at the time the first installation is made.

### B. OUTSIDE SLAB INSTALLATION (Typical outdoor slab installations are shown in Figures 5 and 6.)

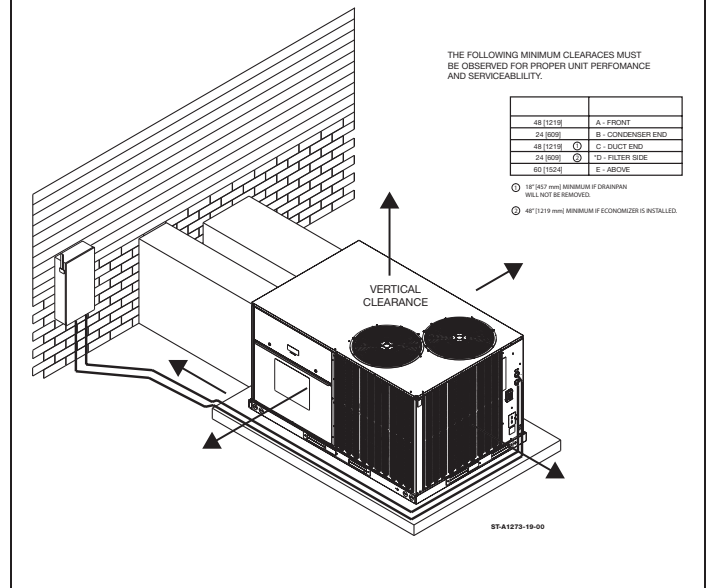
- Select a location where external water drainage cannot collect around the unit.
- Provide a level concrete slab extending 3" [76.2 mm] beyond all four sides of the unit. The slab should be sufficient above grade to prevent ground water from entering the unit. **IMPORTANT:** To prevent transmission of noise or vibration, slab should not be connected to building structure.
- The location of the unit should be such as to provide proper access for inspection and servicing.
- Locate unit where operating sounds will not disturb owner or neighbors.
- Locate unit so roof runoff water does not pour directly on the unit. Provide gutter or other shielding at roof level. Do not locate unit in an area where excessive snow drifting may occur or accumulate.
- It is essential that the unit be elevated above the base pad to allow for condensate drainage and possible refreezing of condensation. Provide a base pad which is slightly pitched away from the structure. Route condensate off base pad to an area which will not become slippery and result in personal injury.
- Where snowfall is anticipated, the height of the unit above the ground level must be considered. Mount unit high enough to be above average area snowfall and to allow for proper condensate drainage.

### C. CLEARANCES

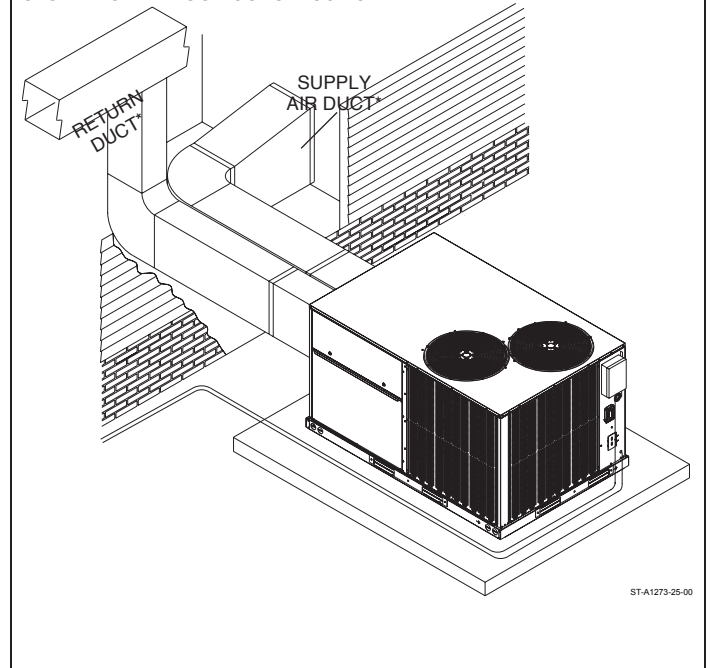
The following minimum clearances must be observed for proper unit performance and serviceability.

- Unit is design certified for application on combustible flooring with 0" minimum clearance.
- See Figure 5 for illustration of minimum installation-service clearances.

**FIGURE 5**  
**PACKAGED HEAT PUMP**  
OUTSIDE SLAB INSTALLATION, BASEMENT OR CRAWL SPACE DISTRIBUTION SYSTEM



**FIGURE 6**  
**PACKAGED HEAT PUMP**  
OUTSIDE SLAB INSTALLATION, CLOSET DISTRIBUTION SYSTEM. SLAB FLOOR CONSTRUCTION

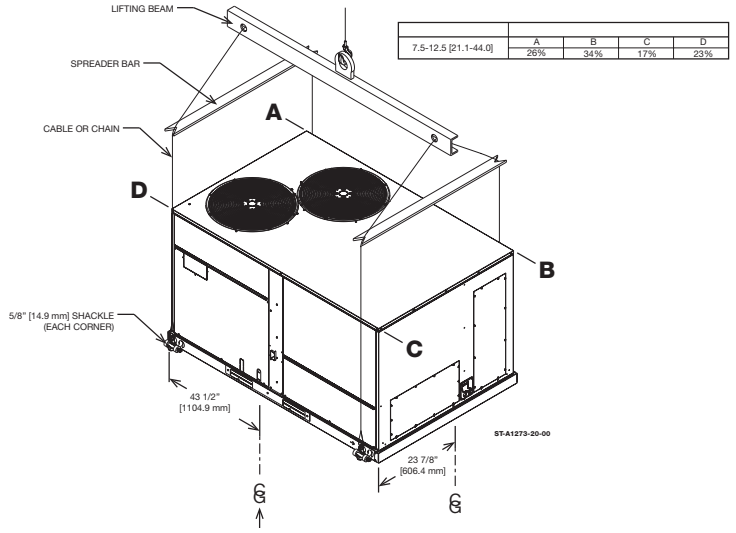


D. ROOFTOP INSTALLATION

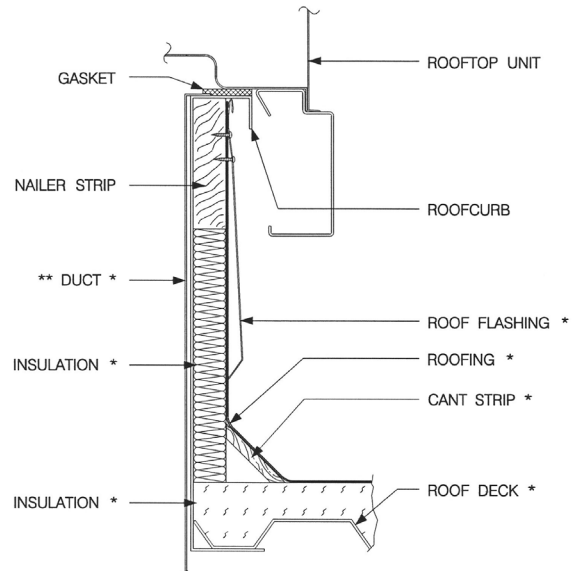
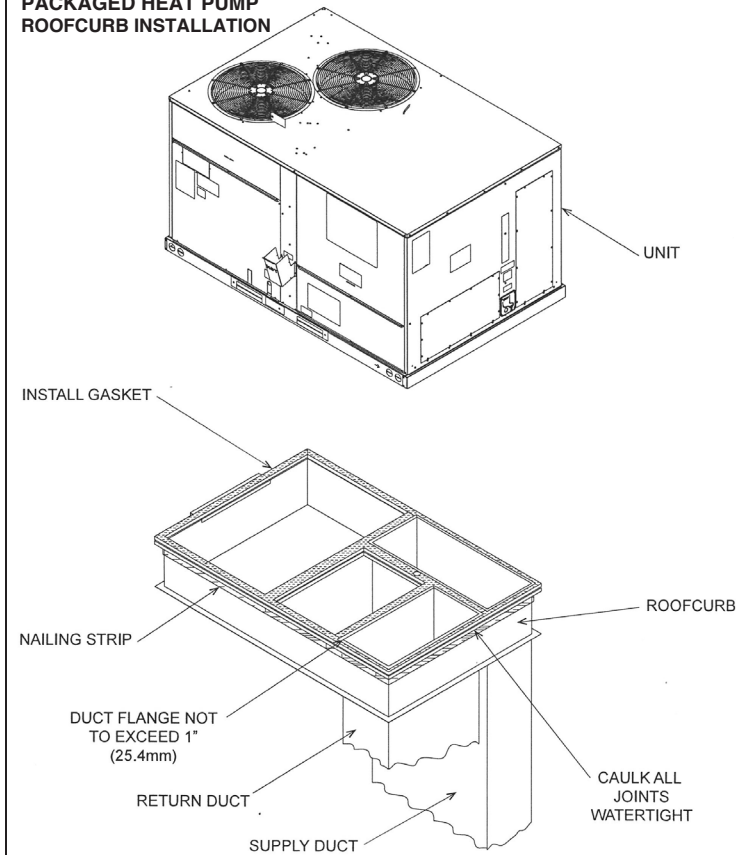
1. Before locating the unit on the roof, make sure that the strength of the roof and beams is adequate at that point to support the weight involved. **This is very important and user's responsibility.**
2. For rigging and roofcurb details, see Figures 7 and 8. Use field-furnished spreaders.
3. For roofcurb assembly, see Roofcurb Installation Instructions.
4. If the roofcurb is not used, provisions for disposing of condensate water runoff during defrosting must be provided.
5. The unit should be placed on a solid and level roofcurb or platform of adequate strength. See Figure 8.
6. The location of the unit on the roof should be such as to provide proper access for inspection and servicing.

**IMPORTANT:** If unit will not be put into service immediately, cover supply and return openings to prevent excessive condensation.

**FIGURE 7  
PACKAGED HEAT PUMP  
RIGGING FOR LIFTING**



**FIGURE 8  
PACKAGED HEAT PUMP  
ROOFCURB INSTALLATION**

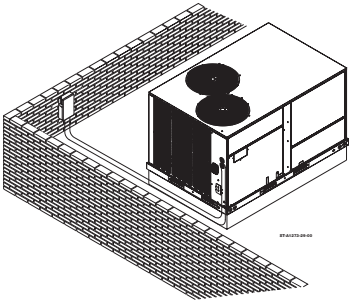
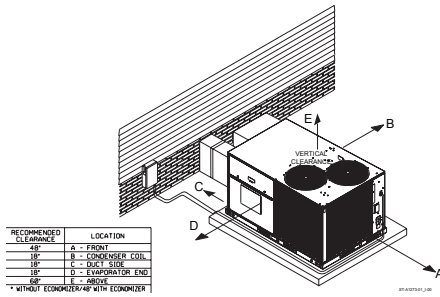


\* BY CONTRACTOR  
 \*\* FOR INSTALLATION OF DUCT AS SHOWN, USE RECOMMENDED DUCT SIZES FROM ROOFCURB INSTALLATION INSTRUCTIONS. FOR DUCT FLANGE ATTACHMENT TO UNIT, SEE UNIT INSTALLATION INSTRUCTIONS FOR RECOMMENDED DUCT SIZES.

ST-A1273-01\_N-00

**FIGURE 9****PACKAGED HEAT PUMP**

FLAT ROOFTOP INSTALLATION, ATTIC OR DROP CEILING  
DISTRIBUTION SYSTEM. MOUNTED ON  
ROOFCURB. CURB MUST BE LEVEL.

**VII. DUCTWORK**

Ductwork should be fabricated by the installing contractor in accordance with local codes and NFPA90A. Industry manuals may be used as a guide when sizing and designing the duct system - contact Air Conditioning Contractors of America, 1513 16th St. N.W., Washington, D.C. 20036.

**▲ WARNING**

**DO NOT, UNDER ANY CIRCUMSTANCES, CONNECT RETURN DUCTWORK TO ANY OTHER HEAT PRODUCING DEVICE SUCH AS A FIREPLACE INSERT, STOVE, ETC. UNAUTHORIZED USE OF SUCH DEVICES MAY RESULT IN FIRE, CARBON MONOXIDE POISONING, EXPLOSION, PROPERTY DAMAGE, SEVERE PERSONAL INJURY OR DEATH.**

The unit should be placed as close to the space to be air conditioned as possible allowing clearance dimensions as indicated. Ducts should be run as directly as possible to supply and return outlets. Use of non-flammable waterproof flexible connectors on both supply and return connections at the unit to reduce noise transmission is recommended.

It is preferable to install the unit on the roof of the structure if the registers or diffusers are located on the wall or in the ceiling. A slab installation could be considered when the registers are low on a wall or in the floor.

On ductwork exposed to outside air conditions of temperature and humidity, use a minimum of 2" [50.8 mm] of insulation and a vapor barrier. Distribution system in attic, furred space or crawl space should be insulated with at least 2" [50.8 mm] of insulation with vapor barrier. One-half to 1" [25.4 mm] thickness of insulation is usually sufficient for ductwork inside the air conditioned space.

Balancing dampers should be provided for each branch duct in the supply system. Ductwork should be properly supported from the structure.

When installing ductwork, consider the following items:

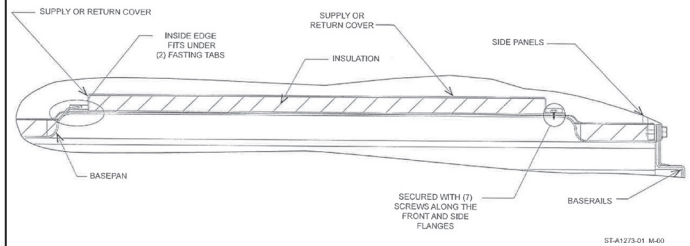
1. Noncombustible flexible connectors should be used between ductwork and unit to reduce noise and vibration transmission into the ductwork.
2. When auxiliary heaters are installed, use noncombustible flexible connectors and clearance to combustible material of 0" for the first 3 feet [0.91 m] of discharge duct. Clearance to unit top and side is 0".

**VIII. FILTERS**

This unit is provided with 4 - 2" x 20" x 20" [51 mm x 508 mm x 508 mm] disposable filters. When replacing filters, ensure they are inserted fully to the back to prevent bypass.

**IX. CONVERSION PROCEDURE****DOWNFLOW TO HORIZONTAL**

1. Remove the screws and covers from the outside of the supply and return sections.
2. Install the covers over the bottom supply and return openings, painted side up inserting the leading flange under the bracket provided. Place the back flange to the top of the front bracket provided. See Figure 10.
3. Secure the return and supply cover to the front bracket with screws.

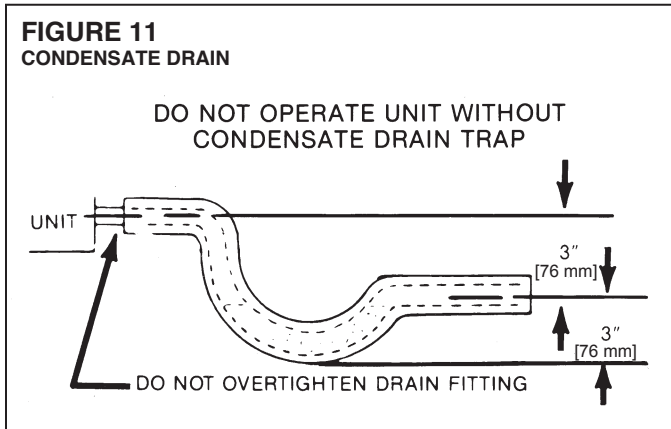
**FIGURE 10  
COVER GASKET DETAIL****X. CONDENSATE DRAIN**

**IMPORTANT: Install a condensate trap to ensure proper condensate drainage. See Figure 11.**

The condensate drain pan has a threaded female 3.4" [19.1 mm] NPT (11.5 TPI) connection. Consult local codes or ordinances for specific requirements of condensate drain piping and disposal.

- To use the removable drain pan feature of this unit, some of the condensate line joints should be assembled for easy removal and cleaning.
- Use a thin layer of Teflon tape or paste on drain pan connections and install only hand tight.
- Do not over tighten drain pan connections as damage to the drain pan may occur.

- Drain line MUST NOT block service access panels.
- Drain line must be no smaller than drain pan outlet and adequately sized to accommodate the condensate discharge from the unit.
- Drain line should slope away from unit a minimum of 1/8" per foot to ensure proper drainage.
- Drain line must be routed to an acceptable drain or outdoors in accordance with local codes.
- Do not connect condensate drain line to a closed sewer pipe.
- Drain line may need insulation or freeze protection in certain applications.



## XI. CONDENSATE DRAIN, OUTDOOR COIL

The outdoor coil during heating operation will sweat or run water off. The outdoor coil will also run water off during the defrost cycle. See Section VI, Installation, Page 48 for mounting precautions.

## XII. ELECTRICAL WIRING

Field wiring must comply with the National Electrical Code (CEC in Canada) and local ordinances that may apply.

### A. POWER WIRING

1. This unit incorporates dual point electrical connections for the unit and electric heat accessory. A single point wiring accessory kit is available for field installation.
2. It is important that proper electrical power is available to the unit. Voltage should not vary more than 10% from the values marked on the unit rating plate. Phase voltages must be balanced within 3%.
3. Install a branch circuit disconnect within sight of the unit. See Figure 17. Use the unit rating plate or RHPD Electrical Data to determine the required size.
4. The branch circuit wire must be sized in accordance with the National Electrical Code (C.E.C. in Canada) and local ordinances that may apply using the minimum circuit ampacity found on the unit rating plate.
5. Field-installed power wiring must be run through grounded rain-tight conduit attached to the unit power entry panel and connected as follows:

# **RXJJ-Series Heater Kit Installation Instructions**

**IMPORTANT:** To ensure proper installation and operation, please read all instructions prior to assembly, installation, operation, maintenance, or repair of this product. After unpacking the heater kit, inspect all parts for damage prior to installation and start up.

## **INTRODUCTION**

The information contained in these instructions has been prepared to assist in the proper installation and operation of the auxiliary electric heaters. Improper installation can result in unsatisfactory operation or dangerous conditions not covered by the unit warranty and may invalidate the Underwriters Laboratories listing.

## **CHECKING PRODUCT RECEIVED**

Upon receiving the heater and any related accessories, inspect all items for shipping damage. Claims for damage should be filed immediately with the shipping company,

Check heater kit and accessory model numbers to determine that they are the correct series for the unit and are of the desired kW size and voltage.

## **APPLICATION**

These auxiliary electric resistance heater kits are designed for installation in the discharge air compartment of the indoor blower. Improper usage can cause results which may be dangerous. Do not use heater kits other than those referenced on the unit rating plate and unit Installation Instructions.

## **OPERATION**

The heater elements are energized through controllers operated by the 24V thermostat circuit in conjunction with the unit integrated electric furnace control board (IFC).

## **TOOLS NEEDED**

The following tools can be helpful in installing the heater kits:

- Slotted screwdrivers and 5/16" nut driver.
- Some kits may require the use of Allen wrenches.
- Needle-nose pliers, large slip-joint pliers.
- Wire cutters and strippers

## **INDOOR BLOWER SPEED**

Refer to the indoor blower airflow tables in the unit installations instructions to set the proper blower speed for your airflow CFM and external static pressure requirements.

**WARNING! DISCONNECT ALL POWER BEFORE BEGINNING HEATER KIT INSTALLATION. FAILURE TO DO SO CAN RESULT IN SEVERE ELECTRICAL SHOCK OR DEATH.**

## **ELECTRICAL WIRING**

Field wiring must comply with applicable National, State, and Local electrical codes and ordinances.



## **POWER WIRING**

If the unit has been in operation without an electric heater kit installed, it may be necessary to change the field installed power wiring. The added current of the electric heater kit may require larger gauge wiring than that required for the unit alone. Refer to the unit rating plate or installation instructions for the required supply circuit ampacity and overcurrent protection.

It is important that adequate electrical power is available to the unit and heater kit. Voltage should not vary more than 10% from that marked on the unit rating plate. Phase voltages must be balanced within 3%.

A properly size disconnect switch or switches shall be located within sight of the unit or as required by applicable National and Local codes.

Power wiring and ground conductor must be routed in rain-tight conduit.

Refer to the unit installation instructions, the illustrations in these instructions, and the unit wiring diagram for power entry, connection, and component locations.

## **HEATER KIT INSTALLATION**

### **Dual Circuit Power Supply Wiring** - (separate heater kit and unit power wiring)

1. Remove package unit blower and heater compartment access panel.
2. Remove unit control box and compressor access panels.
3. Install heater kit in opening under blower deck and secure with the four provided screws (**figure 16**).
4. Route heater power supply wiring from code-compliant disconnect, circuit breaker, or fuse box in rain tight conduit through lower knockout in unit corner post to knockout in outdoor section bulkhead. Label on bulkhead shows knockout location (**figure 12**).
5. Connect heater kit field power wiring to terminal block on heater kit.
6. Connect heater kit grounding conductor to ground lug on heater kit.
7. Connect heater kit control plug to receptacle in heater kit area.
8. Route unit power supply wiring from code-compliant disconnect, circuit breaker, or fuse box in rain tight conduit through upper knockout in unit corner post to opening in bottom of control box below unit contactor.
9. Connect unit field power supply wiring to unit contactor.
10. Connect unit grounding conductor to ground lug in unit control box.
11. Reinstall all access panel.
12. Verify proper unit operation.

**Single-Point Unit Wiring** - (unit and heater kit power supplied from a single circuit) requires optional **RXJX**-series single-point connection box kit.

KIT MODEL #	VOLTS	UNIT APPLICATION
RXJX-AC0605	C VOLTAGE 240V	ACD 090/102
RXJX-AC0805	C VOLTAGE 240V	ACD 120
RXJX-AD0605	D VOLTAGE 480/600V	ACD 090/102/120
RXJX-AC0805	C VOLTAGE 240V	HPD 090/102
RXJX-AD0405	D VOLTAGE 480/600V	HPD 090/102
RXJX-AC0909	C VOLTAGE 240V	ACD 150
RXJX-AD0609	D VOLTAGE 480/600V	ACD 150
RXJX-AC0909	C VOLTAGE 240V	HPD 120
RXJX-AD0409	D VOLTAGE 480/600V	HPD 120

1. Verify that you have the correct RXJX kit. Refer to above table.
2. Remove package unit blower and heater kit access panels.
3. Remove package unit control box and compressor access panels.
4. Install heater kit in opening under blower deck and secure to blower deck flange and unit base rail with the four screws provided (**figure 16**).
5. Install RXJX single-point connection box as described below.
  - a. Remove and retain three screws in bulkhead (**figure 12**).
  - b. Remove knockout from bulkhead blockoff (**figure 12**, label indicates location).
  - c. Remove left side top and bottom panels from single-point box to allow access to bulkhead securement screws (**figure 13**).
  - d. Position single-point box directly against blower bulkhead. Note that the flange on the bulkhead blockoff slides through the slot in the right side of the box (**figure 13**).
  - e. Secure box to bulkhead with the three screws removed in step “5a” above.
  - f. Secure box to unit base pan with two additional screws included with kit (**figure 13**).
  - g. Remove concentric knock-out from left side bottom panel as required
  - h. Reinstall left side top and bottom panels (**figures 14 & 15**).
  - i. Install snap bushing through hole in single-point box and blower bulkhead (**figure 16**).
6. Route power supply wiring from code-compliant disconnect, circuit breaker, or fuse box in rain tight conduit through lower knockout in unit corner post to knockout in side of single-point connection box.
7. Connect power wiring to terminal block in single-point box.
8. Connect grounding conductor to ground lug in single-point box.
9. Connect unit power leads from fuse block to L1, L2, L3 on unit contactor in unit control box.
10. Connect heater kit wiring leads from terminal block in single-point kit through bulkhead opening to terminal block on heater kit.
11. Connect heater kit control plug to receptacle in heater kit area.
12. Reinstall all access panels.
13. Verify proper unit operation.

FIGURE 12

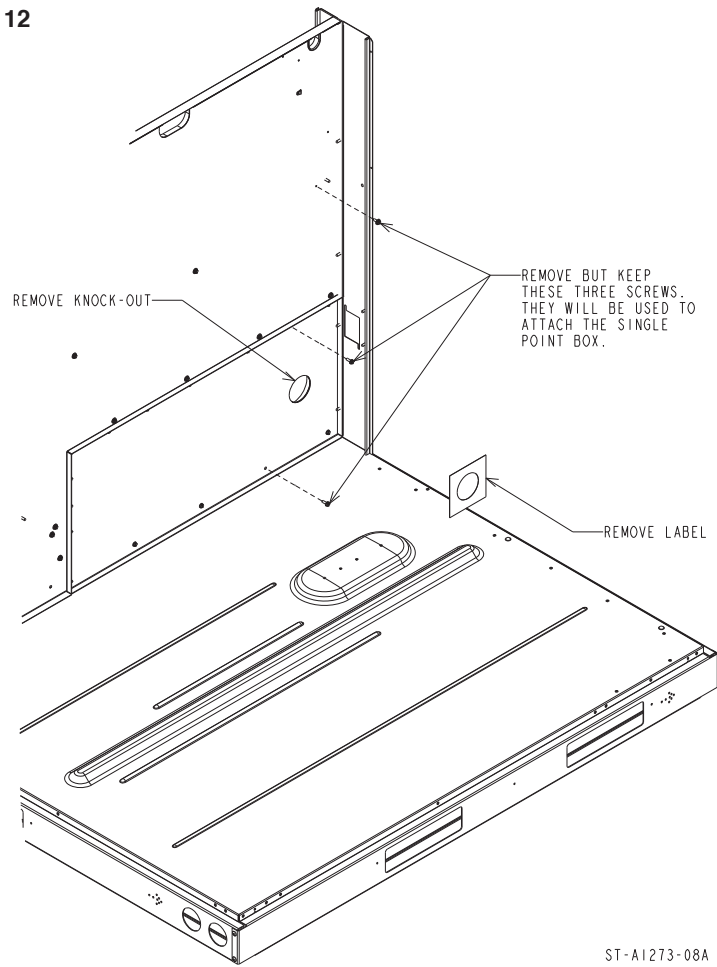


FIGURE 13

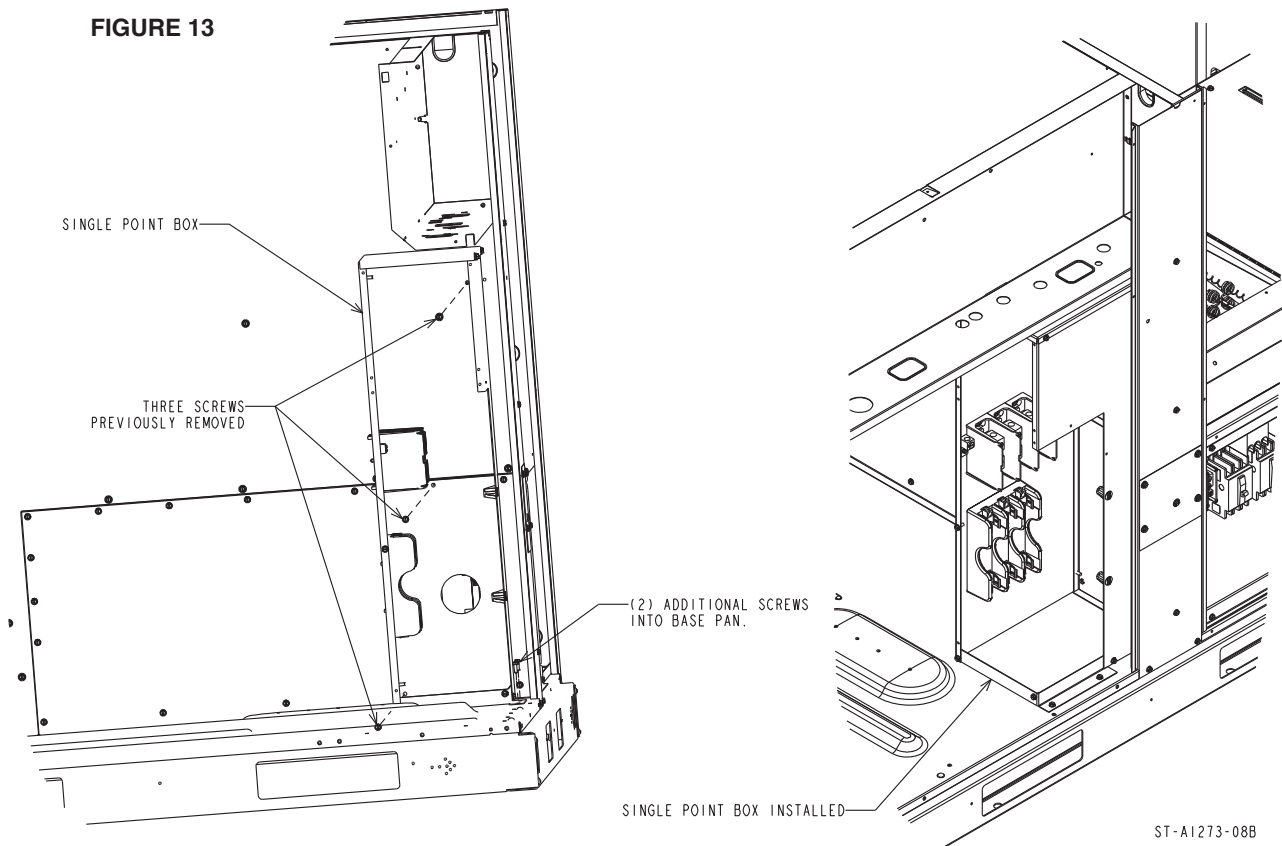


FIGURE 14

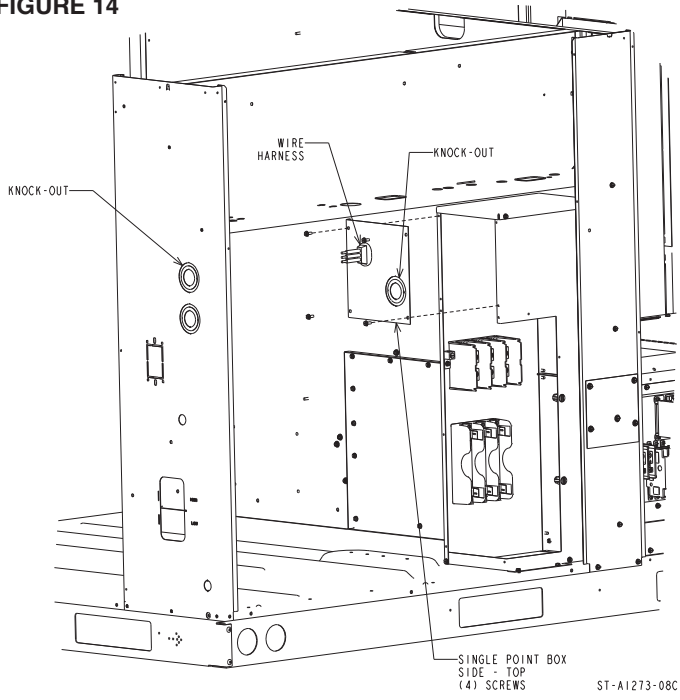


FIGURE 15

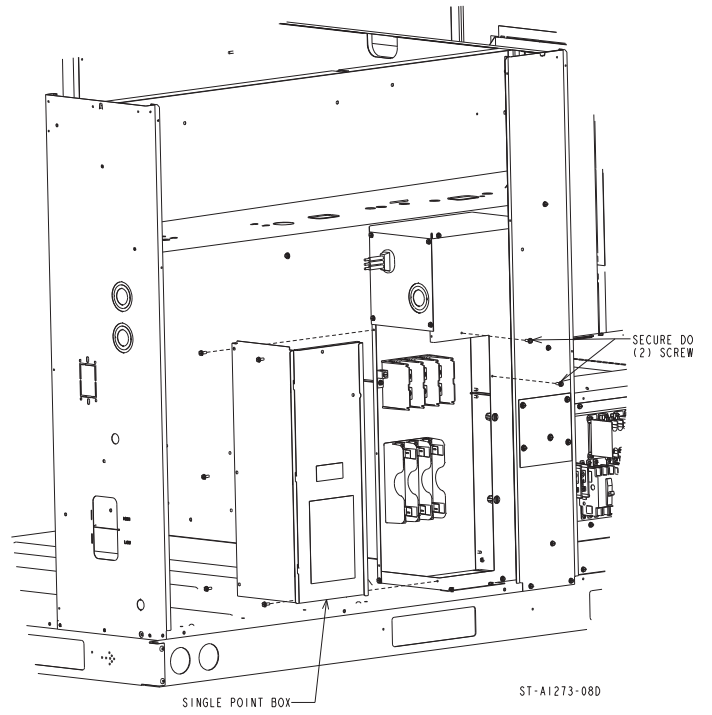
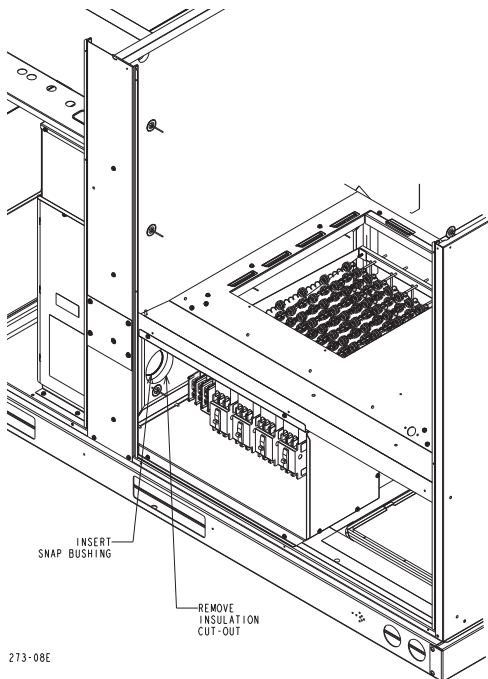
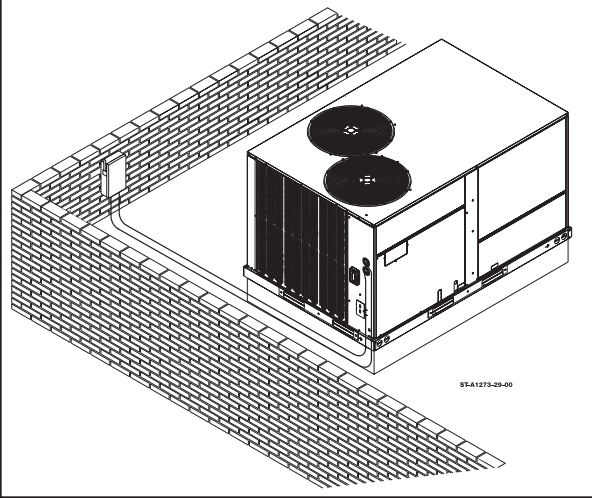


FIGURE 16



**FIGURE 17**  
**BRANCH CIRCUIT DISCONNECT LOCATION**



**B. CONTROL WIRING (Class II)**

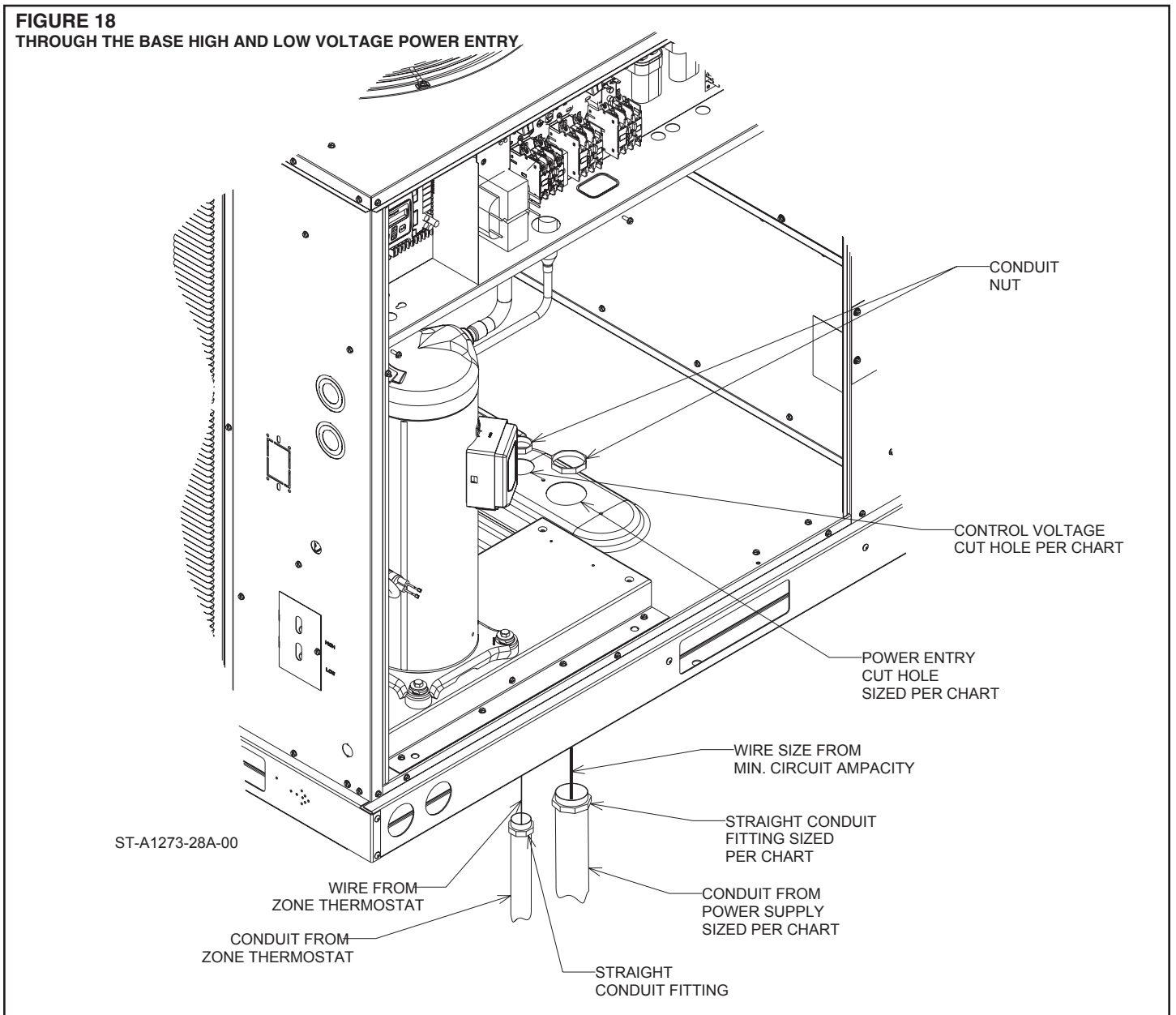
1. Low voltage wiring should not be run in conduit with power wiring.
2. Control wiring is routed through the 7/8" [22 mm] hole in the unit side panel. Use a minimum #18 AWG thermostat wire. For wire lengths exceeding 50' [15.24 m] use #16 AWG thermostat wire. Connect the control wiring to the low voltage terminal block located on the unit integrated control. Route wires under the control voltage shield. See Figure 15.
3. It is necessary that only approved thermostats be used. Please contact your distributor for part number information. See thermostat specification catalog for recommended thermostat.
4. Figure 18 shows representative low voltage connection diagrams. Read your thermostat installation instructions for any special requirements for your specific thermostat.

**C. INTERNAL WIRING**

1. A diagram of the internal wiring of this unit is located on the inside of the control access panel and in this manual. If any of the original wiring must be replaced, the wire gauge and insulation must be the same as original wiring.

Transformer is factory-wired for 230 volts on 208/230 volt models and must be changed for 208-volt applications. See unit wiring diagram for 208-volt wiring.

**FIGURE 18**  
**THROUGH THE BASE HIGH AND LOW VOLTAGE POWER ENTRY**



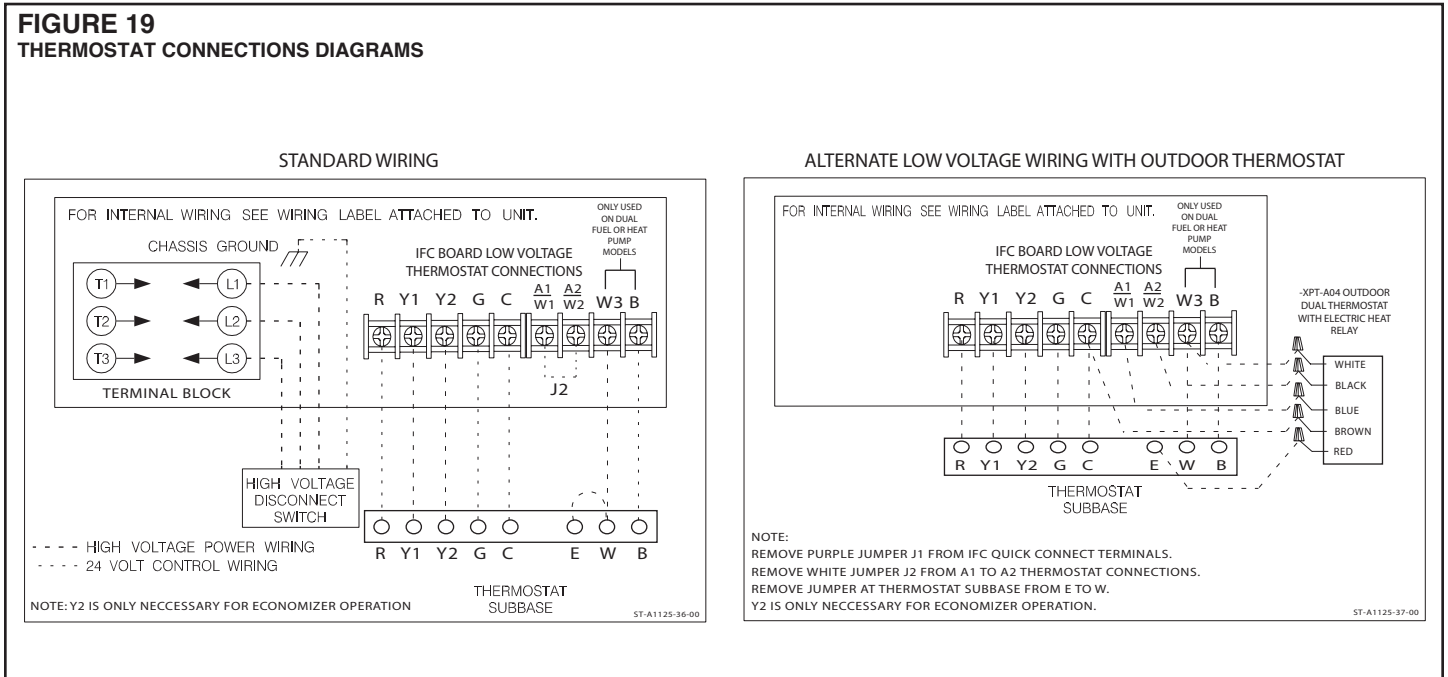
**TABLE 1. COPPER WIRE SIZE — AWG (1% VOLTAGE DROP)**

	300	4	3	2	2	1	1/0	1/0	2/0	2/0	3/0	3/0	3/0	4/0	4/0	4/0	250	250	250	250	300	300	300
Supply	250	4	4	3	3	2	1	1	1/0	1/0	2/0	2/0	2/0	3/0	3/0	3/0	4/0	4/0	4/0	4/0	250	250	250
Wire	200	6	4	4	4	3	2	2	1	1	1/0	1/0	1/0	2/0	2/0	2/0	3/0	3/0	3/0	3/0	4/0	4/0	4/0
Length	150	8	6	6	4	4	4	3	3	2	2	1	1	1/0	1/0	1/0	2/0	2/0	2/0	2/0	2/0	3/0	3/0
Feet	100	10	8	8	6	6	6	4	4	4	3	3	2	2	2	1	1	1	1	1	1/0	1/0	1/0
	50	14	12	10	10	8	8	6	6	6	4	4	4	3	3	3	2	2	2	2	2	1	1
		15	20	25	30	35	40	45	50	55	60	65	70	75	80	85	90	95	100	105	110	115	120

Circuit Ampacity

NOTE:  
 1. Wire size based on 60°C type copper conductors below 100 ampacity. 2. Wire size based on 75°C type copper conductors for 100 ampacity and above.

**FIGURE 19  
THERMOSTAT CONNECTIONS DIAGRAMS**



**D. GROUNDING**

**▲ WARNING**

**THE UNIT MUST BE PERMANENTLY GROUNDED. A GROUNDING LUG IS PROVIDED IN THE ELECTRIC HEAT ACCESS AREA FOR A GROUND WIRE. FAILURE TO GROUND THIS UNIT CAN RESULT IN FIRE OR ELECTRICAL SHOCK CAUSING PROPERTY DAMAGE, SEVERE PERSONAL INJURY OR DEATH.**

GROUNDING MAY ALSO BE ACCOMPLISHED BY GROUNDING THE POWER LINE CONDUIT TO THE UNIT. MAKE SURE THE CONDUIT NUT LOCKING TEETH HAVE PIERCED THE INSULATING PAINT FILM OF THE SIDE PANEL.

**E. THERMOSTAT**

The thermostat should be mounted on an inside wall about five feet above the floor in a location where it will not be affected by unconditioned air, sun, or drafts from open doors or other sources. READ installation instructions in heat pump thermostat package CAREFULLY because each has some different wiring requirements.

**XIII. INDOOR AIR FLOW DATA**

Belt-drive blower models have motor sheaves set for proper CFM at a typical external static. See Airflow Data Tables to determine if adjustments are necessary.

**XIV. CRANKCASE HEAT**

Crankcase heat is standard on 7½ & 10 ton models. The auxiliary switch on the compressor contactor turns off the heater when the compressor is running.

**XV. PRE-START CHECK**

1. Is unit properly located and slightly slanted toward indoor condensate drain?
2. Is ductwork insulated, weatherproofed, with proper spacing to combustible materials?
3. Is air free to travel to and from outdoor coil? (See Figure 5.)
4. Is the wiring correct, tight, and according to unit wiring diagram?
5. Is unit grounded?
6. Are field supplied air filters in place and clean?
7. Do the outdoor fan and indoor blower turn freely without rubbing, and are they tight on the motor shafts?
8. Is unit elevated to allow for outdoor coil condensate drainage during heating operation and defrost?

**XVI. STARTUP**



1. Turn thermostat to "OFF," turn "on" power supply at disconnect switch.
2. Turn temperature setting as high as it will go.
3. Turn fan switch to "ON."
4. Indoor blower should run. Be sure it is running in the right direction.
5. Turn fan switch to "AUTO." Turn system switch to "COOL" and turn temperature setting below room temperature. Unit should run in cooling mode after 5 minute compressor on-delay has expired.
6. Are outdoor fans operating correctly in the right direction?
7. Is compressor running correctly?
8. Record the following after the unit has run some time.
  - A. Operating Mode \_\_\_\_\_
  - B. Discharge Pressures (High) \_\_\_\_\_ PSIG
  - C. Vapor Pressure at Compressors (Low) \_\_\_\_\_ PSIG
  - D. Vapor Line Temperature at Compressors \_\_\_\_\_ °F.
  - E. Indoor Dry Bulb \_\_\_\_\_ °F.
  - F. Indoor Wet Bulb \_\_\_\_\_ °F.
  - G. Outdoor Dry Bulb \_\_\_\_\_ °F.
  - H. Outdoor Wet Bulb \_\_\_\_\_ °F.
  - I. Voltage at Contactor \_\_\_\_\_ Volts
  - J. Current at Contactors \_\_\_\_\_ Amps
  - K. Model Number \_\_\_\_\_
  - L. Serial Number \_\_\_\_\_
  - M. Location \_\_\_\_\_
  - N. Owner \_\_\_\_\_
  - O. Date \_\_\_\_\_
9. Turn thermostat system switch to "HEAT." Unit should stop. Raise temperature setting to above room temperature. Unit should run in heating mode after 5 minute delay. Auxiliary heaters, if installed, will energize 30 to 50 seconds after the initiation of a "W3" call.
10. Check the refrigerant charge using the instructions located on compressor access panel cover. Replace service port caps. Service port cores are for system access only and will leak if not tightly capped.
11. Adjust discharge air grilles and balance system.
12. Check ducts for condensation and air leaks.
13. Check unit for tubing and sheet metal rattles.
14. Instruct the owner on operation and maintenance.
15. Leave "INSTALLATION" and "USE AND CARE" instructions with owner.

## XVII. OPERATION

### COOLING MODE

With thermostat in the cool mode, fan auto and the room temperature higher than the thermostat setting:

- A. Indoor blower contactor is energized through thermostat contact (G).
- B. Compressor contactor is energized through thermostat contact (Y1). A 5 minute short cycle delay is standard on this unit. Compressor will start immediately if test pins on the defrost board are shorted and released.
- C. Reversing valve is de-energized in the cooling mode through thermostat contact (B).
- D. Economizer enthalpy control (if installed) controls operation of first-stage cooling and positions fresh air damper to maintain mixed air temperature. Second-stage cooling operates normally as required by second stage of thermostats.
- E. The system will continue in cooling operation as long as all safety controls are closed, until the thermostat is satisfied.

### HEATING MODE

With thermostat in the heat mode, fan auto and the room temperature lower than the thermostat setting:

- A. Indoor blower contactor is energized through thermostat contact (G).
- B. Compressor contactor is energized through thermostat contact (Y1). A 5 minute short cycle delay is standard on this unit. Compressor will start immediately if test pins on the defrost board are shorted and released.
- C. Reversing valve is energized in the heating mode through thermostat contact (B).
- D. Economizer enthalpy control (if installed) is electrically bypassed with the heat pump control relay during heating operation.
- E. Should the heat requirement be more than the heat pump can supply, a portion of the electric heat accessory (if supplied) is energized through thermostat contact (W3).
- F. The system will continue in heating operation as long as all safety controls are closed, until the thermostat is satisfied.
- G. The unit will function in a defrost mode, reversing the refrigerant cycle to cooling and energizing the electric heat (if supplied) as required through the defrost relay.
- H. If the refrigerant system becomes inoperable during a need for heating, the thermostat may be set to emergency heat which will energize the electric heat (if supplied).

At initial start-up or after extended shutdown periods make sure the crankcase heater is energized for at least 12 hours before the compressor is started.

## XVIII. AUXILIARY HEAT

The amount of auxiliary heat required depends on the heat loss of the structure to be heated and the capacity of the heat pump. It is good practice to install strip heat to maintain at least 60°F indoor temperatures in case of compressor failure. The auxiliary heat is energized by the second stage of the thermostat. The amount of electric heat that is allowed to come on, as determined by the output of the heat pump, may be controlled by an outdoor thermostat.

### ▲ WARNING

**ONLY ELECTRIC HEATER KITS SUPPLIED BY THIS MANUFACTURER AS DESCRIBED IN THIS PUBLICATION HAVE BEEN DESIGNED, TESTED, AND EVALUATED BY A NATIONALLY RECOGNIZED SAFETY TESTING AGENCY FOR USE WITH THIS UNIT. USE OF ANY OTHER MANUFACTURED ELECTRIC HEATERS INSTALLED WITHIN THIS UNIT MAY CAUSE HAZARDOUS CONDITIONS RESULTING IN PROPERTY DAMAGE, FIRE, BODILY INJURY OR DEATH.**

## XIX. DEMAND DEFROST CONTROL AND HIGH/LOW PRESSURE CONTROLS

The demand defrost control monitors the outdoor ambient temperature, outdoor coil temperature and the compressor run time to determine when a defrost cycle is required.

**Enhanced Feature Demand Defrost Control:** This defrost control has high and low pressure control inputs with unique pressure switch logic built into the microprocessor to provide compressor and system protection without nuisance lockouts. The control cycles the compressor off for 30 seconds at the beginning and the end of the defrost cycle to eliminate the increased compressor noise caused by rapidly changing system pressures when the reversing valve switches. See next page for diagnostic flash codes and sensor resistance values at various temperatures.

## DEFROST INITIATION

A defrost will be initiated when the three conditions below are satisfied:

- 1.The outdoor coil temperature is below 35°F as measured by a good coil sensor,
- 2.The compressor has operated for at least 34 minutes with the outdoor coil temperature below 35°F and
- 3.The measured difference between the ambient temperature and the outdoor coil temperature is greater than the calculated difference determined by the defrost control micro-processor.

## DEFROST TERMINATION

Once a defrost is initiated, the defrost will continue until fourteen minutes has elapsed or the coil temperature has reached the selected termination temperature. The factory setting is 70°F but can be changed to 50°F, 60°F, or 80°F by relocating the jumper on the control board.

## TEMPERATURE SENSORS

The coil sensor is located on the outdoor coil near the point fed by the distribution tubes from the expansion device, on the top most cross-over tube. The ambient air sensor is located outside the control box so it can sense outdoor temperatures.

If the ambient sensor fails, the defrost control will initiate a defrost every 34 minutes of compressor run time with the coil temperature below 35°F.

If the coil sensor fails, the defrost control will not initiate a defrost.

## TEST MODE

The test mode is initiated by shorting the TEST pins. The unit must have an active heat pump heating call to enter the test mode. In this mode of operation, the enable temperature is ignored and all timers are sped up. To initiate a manual defrost, short and hold the TEST pins. Remove the short when the system switches to defrost mode after the compressor noise abatement delay. The defrost will terminate on time (14 minutes) or when the termination temperature has been reached.

Test Sequence of Operation:

- 1)Provide a heating call to the heat pump.
- 2)Short test pins to bypass anti-short cycle timer. (If unit is running, this step is not necessary.)
- 3)Short test pins and hold them shorted to enter defrost mode.
- 4)Release test pins once control exits noise abatement delay.
- 5)Monitor coil temperature when control exits defrost.
- 6)Unit should return to heating mode.

## TROUBLESHOOTING DEMAND DEFROST

During the test mode the coil temperature should be monitored. If the system exits defrost at approximately the termination temperature, the control is operating normally. If not, check the coil and ambient temperature sensor resistances, using the sensor temperature vs. resistance table at the end of this section.

Immerse the sensor in water and measure the resistance of the sensor. At 35°F the resistance of the sensor should be approximately 30,000 ohms.

Ensure that the coil sensor is properly installed that is not loose or touching the cabinet.

## HIGH/LOW PRESSURE CONTROL MONITORING -

## ENHANCED DEFROST CONTROL

Status of high and low pressure controls is monitored by the enhanced feature demand defrost control and the following actions are taken.

**High Pressure Control** – Provides active protection in both cooling and heating modes at all outdoor ambient temperatures. The high pressure control is an automatic reset type and opens at approximately 610 psig and closes at approximately 420 psig. The compressor and fan motor will stop when the high pressure control opens and will start again if the high side pressure drops to approximately 420 psig where the automatic reset high pressure control resets. If the high pressure control opens 3 times within a particular call for heating or cooling operation, the defrost control will lock out compressor and outdoor fan operation.

**Low Pressure Control** – Provides active protection in both heating and cooling modes at all outdoor ambient temperatures. The low pressure control is an automatic reset type and opens at approximately 15 psig and closes at approximately 40 psig. Operation is slightly different between cooling and heating modes.

**Cooling Mode:** The compressor and fan motor will stop when the low pressure control opens and will start again when the low side pressure rises to approximately 40 psig after the low pressure control automatically resets. If the low pressure switch opens 3 times within a particular call for cooling operation, the defrost control will lock out compressor and outdoor fan operation.

**Heating Mode:** The compressor and outdoor fan motor will stop when the low pressure control opens and will start again when the low side pressure rises to approximately 40 psig when the low pressure control automatically resets. If the low pressure switch trips 3 times within 120 minutes of operation during a particular call for heating operation, the defrost control will lock out compressor and outdoor fan operation. If the lock-out due to low pressure occurs at an outdoor ambient temperature below 5°F, the defrost control will automatically exit the lock-out mode when the outdoor ambient temperature rises to 5°F. This feature is necessary since the low pressure control could possibly have opened due to the outdoor ambient being very low rather than an actual system fault.

**Exiting Lock-Out Mode:** To exit the lock-out mode, remove 24 volts to the defrost control by removing power to the unit or by shorting the two defrost control pins together.

## ENHANCED FEATURE DEFROST CONTROL DIAGNOSTIC CODES SENSOR TEMPERATURE VS. RESISTANCE

## TABLE REPLACEMENT PARTS

LED 1	LED 2	Control Board Status
OFF	OFF	No Power
ON	ON	Coil Sensor Failure
OFF	ON	Ambient Sensor Failure
FLASH	FLASH	Normal
OFF	FLASH	Low Pressure Lockout (short test pins to reset)
FLASH	OFF	High Pressure Lockout (short test pins to reset)
ON	FLASH	Low Pressure Control Open
FLASH	ON	High Pressure Control Open
Alternate Flashing		5 Minute Time Delay

Contact your local distributor for a complete parts list.

Degrees C	Degrees F	Ohms
-20	-4	96,974
-10	14	55,298
0	32	32,650
10	50	19,903
20	68	12,493
25	77	10,000
30	86	8,056
40	104	5,324

## CHARGE INFORMATION

Refer to the appropriate charge chart on the unit, or in this booklet.

## TROUBLESHOOTING

Refer to the troubleshooting chart included in this manual.

## WIRING DIAGRAMS

Refer to the appropriate wiring diagram included in this manual.

# AIRFLOW PERFORMANCE — RHPDZ\*090\*

## AIRFLOW PERFORMANCE — 7.5 TON [26.4kW] — 60 Hz — DOWNFLOW

Air Flow CFM [L/s]		External Static Pressure — Inches of Water [kPa]																																						
		0.1 [0.02]	0.2 [0.05]	0.3 [0.07]	0.4 [0.10]	0.5 [0.12]	0.6 [0.15]	0.7 [0.17]	0.8 [0.20]	0.9 [0.22]	1.0 [0.25]	1.1 [0.27]	1.2 [0.30]	1.3 [0.32]	1.4 [0.35]	1.5 [0.37]	1.6 [0.40]	1.7 [0.42]	1.8 [0.45]	1.9 [0.47]	2.0 [0.50]																			
2400 [1133]	—	551	782	585	814	619	848	652	885	684	926	717	969	748	1016	780	1066	810	1118	841	1174	870	1233	900	1294	929	1359	957	1427	985	1498	1012	1572	1039	1649	1065	1729	1091	1813	
2500 [1180]	—	562	816	596	848	629	884	661	923	693	984	725	1009	756	1057	787	1108	817	1162	846	1219	876	1279	904	1343	933	1409	960	1478	987	1550	1014	1626	1040	1704	1066	1786	1092	1870	
2600 [1227]	—	574	851	607	885	639	922	671	962	702	1006	733	1062	764	1101	794	1153	823	1209	852	1267	881	1329	909	1393	937	1461	964	1531	990	1605	1016	1682	1042	1762	1067	1844	1092	1930	
2700 [1274]	553	585	889	618	925	650	963	681	1004	712	1049	742	1096	772	1147	801	1201	830	1258	858	1317	886	1380	914	1446	941	1515	967	1587	993	1662	1019	1740	1044	1821	1068	1905	1092	1993	
2800 [1321]	565	896	597	930	629	966	660	1006	691	1049	721	1095	751	1144	780	1196	808	1251	837	1308	864	1370	892	1434	919	1501	945	1572	971	1645	996	1721	1021	1801	1045	1883	1069	1969	1093	2057
2900 [1368]	577	937	609	972	640	1010	670	1051	701	1096	730	1143	759	1193	788	1246	816	1303	843	1362	871	1425	897	1490	923	1559	949	1630	974	1705	999	1783	1023	1864	1047	1948	1070	2035	1093	2124
3000 [1416]	590	981	1017	651	1057	681	1099	710	1145	739	1193	768	1245	796	1300	823	1357	850	1418	877	1482	903	1549	928	1619	953	1692	978	1768	1002	1847	1026	1929	1049	2014	1072	2103	1094	2194	
3100 [1463]	602	1027	633	1085	662	1105	692	1149	720	1196	749	1246	777	1299	804	1355	831	1414	857	1476	883	1541	908	1610	933	1681	958	1755	982	1833	1005	1913	1028	1997	1051	2083	1073	2173	1094	2266
3200 [1510]	615	1075	645	1114	674	1157	702	1202	731	1250	758	1301	785	1356	812	1413	838	1473	864	1535	891	1600	916	1673	944	1743	967	1800	989	1970	1012	2053	1033	2139	1055	2229	1075	2321	1096	2416
3300 [1557]	628	1126	657	1166	685	1210	713	1256	741	1306	768	1359	794	1414	820	1473	846	1535	871	1600	896	1668	920	1739	944	1813	967	1890	989	1970	1012	2053	1033	2139	1055	2229	1075	2321	1096	2416
3400 [1604]	640	1179	669	1221	697	1266	724	1314	751	1365	777	1419	803	1476	829	1536	854	1599	878	1665	902	1734	926	1807	949	1882	971	1960	993	2042	1015	2126	1036	2214	1057	2305	1077	2398	1097	2495
3500 [1652]	653	1235	681	1278	708	1324	735	1373	761	1425	787	1481	812	1539	837	1601	861	1665	885	1733	909	1803	932	1877	954	1954	976	2034	997	2116	1018	2202	1039	2291	1059	2383	1078	2478	1097	2576
3600 [1699]	666	1292	693	1337	720	1384	746	1435	771	1489	797	1545	821	1605	845	1668	869	1734	892	1803	915	1875	938	1950	959	2028	981	2109	1001	2193	1022	2280	1042	2371	1061	2464	1080	2560	1098	2660

NOTE: A/F-Drive left of bold line, B/G-Drive right of bold line, C/H-Drive right of double line.

Drive Package	A/F	B/G	C/H
Motor H.P. [W]	2 [1491.4]	3 [2237.1]	3 [2237.1]
Blower Sheave	AK84H	AK84H	AK84H
Motor Sheave	1V1.40*7/8	1VP50*7/8	1VP56*7/8
Belt	A49	A50	A51
Turns Open	0	1	2
RPM	767	721	678
			635
			590
			548
			992
			949
			908
			866
			823
			782
			740
			698
			656
			614
			572
			530
			488
			446
			404
			362
			320
			278
			236
			194
			152
			110
			68
			26

- NOTES: 1. Factory sheave settings are shown in bold type.  
 2. Do not set motor sheave below minimum or maximum turns open shown.  
 3. Re-adjustment of sheave required to achieve rated airflow at AHR1 minimum External Static Pressure  
 4. Drive data shown is for vertical airflow with dry coil. Add component resistance (below) to duct resistance to determine total External Static Pressure.

Airflow	AIRFLOW CORRECTION FACTORS *		COMPONENT AIRFLOW RESISTANCE			
	CFM [L/s]	Total MBH	Sensible MBH	Power kW	Resistance — Inches of Water [kPa]	Wet Coil
2400 [1133]	0.97	0.92	0.93	0.99	0.01 [0.00]	Concentric Diffuser RXRN-AEF2000 & Concentric Adapter RXMC-DD01 (Flush)
2500 [1180]	0.97	0.93	0.95	0.99	0.06 [0.01]	Concentric Diffuser RXRN-AED2000 & Concentric Adapter RXMC-DD01 (Drop)
2600 [1227]	0.98	0.96	0.98	0.99	0.02 [0.00]	Vertical Economizer RA Damper Open
2700 [1274]	0.99	0.96	0.99	0.99	0.06 [0.01]	Concentric Diffuser RXRN-AEF2000 & Concentric Adapter RXMC-DD01 (Flush)
2800 [1321]	0.99	0.98	1.00	1.00	0.07 [0.02]	Concentric Diffuser RXRN-AED2000 & Concentric Adapter RXMC-DD01 (Drop)
2900 [1368]	1.00	1.00	1.00	1.00	0.04 [0.01]	Vertical Economizer RA Damper Open
3000 [1416]	1.01	1.01	1.01	1.00	0.04 [0.01]	Concentric Diffuser RXRN-AEF2000 & Concentric Adapter RXMC-DD01 (Flush)
3100 [1463]	1.01	1.03	1.03	1.00	0.05 [0.01]	Concentric Diffuser RXRN-AED2000 & Concentric Adapter RXMC-DD01 (Drop)
3200 [1510]	1.02	1.04	1.04	1.01	0.06 [0.02]	Vertical Economizer RA Damper Open
3300 [1557]	1.02	1.06	1.06	1.01	0.07 [0.02]	Concentric Diffuser RXRN-AEF2000 & Concentric Adapter RXMC-DD01 (Flush)
3400 [1604]	1.03	1.08	1.08	1.01	0.08 [0.02]	Concentric Diffuser RXRN-AED2000 & Concentric Adapter RXMC-DD01 (Drop)
3500 [1652]	1.04	1.09	1.09	1.01	0.09 [0.02]	Vertical Economizer RA Damper Open
3600 [1699]	1.04	1.11	1.11	1.02	0.10 [0.02]	Concentric Diffuser RXRN-AEF2000 & Concentric Adapter RXMC-DD01 (Flush)

\* Multiply correction factor times gross performance data — resulting sensible capacity cannot exceed total capacity. [ ] Designates Metric Conversions

# AIRFLOW PERFORMANCE — RHPDZ\*090\*

## AIRFLOW PERFORMANCE — 7.5 TON [26.4kW] — 60 Hz — SIDEFLOW

**Model RHPDZ\*090\*** Voltage 208/230, 460, 575 — 3 phase 60 Hz

Air Flow CFM [L/s]	External Static Pressure — Inches of Water [kPa]																																								
	0.1 [.02]		0.2 [.05]		0.3 [.07]		0.4 [.10]		0.5 [.12]		0.6 [.15]		0.7 [.17]		0.8 [.20]		0.9 [.22]		1.0 [.25]		1.1 [.27]		1.2 [.30]		1.3 [.32]		1.4 [.35]		1.5 [.37]		1.6 [.40]		1.7 [.42]		1.8 [.45]		1.9 [.47]		2.0 [.50]		
	RPM	W	RPM	W	RPM	W	RPM	W	RPM	W	RPM	W	RPM	W	RPM	W	RPM	W	RPM	W	RPM	W	RPM	W	RPM	W	RPM	W	RPM	W	RPM	W	RPM	W	RPM	W	RPM	W	RPM	W	RPM
2400 [1133]	—	—	—	558	822	594	853	629	887	663	925	697	965	730	1009	763	1056	794	1106	826	1159	856	1216	886	1275	915	1338	943	1404	971	1474	998	1546	1025	1622	1051	1700	1076	1782		
2500 [1180]	—	—	—	568	848	604	881	638	917	672	956	705	988	738	1044	769	1092	801	1144	831	1199	861	1258	890	1319	919	1384	947	1452	974	1523	1001	1597	1027	1674	1052	1755	1077	1838		
2600 [1227]	—	—	543	846	579	877	613	912	647	681	991	713	1035	745	1082	777	1132	807	1186	837	1243	867	1303	895	1366	923	1433	951	1502	978	1575	1004	1651	1029	1730	1054	1812	1078	1898		
2700 [1274]	—	—	554	877	589	910	623	946	657	689	1029	722	1074	753	1124	784	1176	814	1231	844	1290	872	1352	901	1417	928	1485	955	1556	981	1631	1007	1708	1032	1789	1056	1873	1079	1961		
2800 [1321]	—	—	566	911	600	946	634	984	666	699	1070	730	1118	751	1169	792	1223	821	1280	850	1340	878	1404	906	1470	933	1540	959	1613	985	1689	1010	1769	1034	1852	1058	1938	1081	2027		
2900 [1368]	543	916	577	949	611	986	644	1026	676	708	1115	739	1164	770	1217	799	1273	828	1332	857	1394	885	1459	912	1528	938	1599	964	1674	989	1752	1014	1833	1037	1918	1061	2005	1083	2096		
3000 [1416]	555	955	589	990	622	1029	655	1070	687	718	1163	748	1214	778	1269	807	1326	836	1387	864	1451	891	1518	918	1588	944	1662	969	1738	994	1818	1017	1901	1041	1987	1063	2077	1085	2169		
3100 [1463]	568	998	601	1035	634	1075	666	1118	697	728	1215	758	1268	787	1324	816	1383	844	1445	871	1511	898	1580	924	1652	949	1727	974	1806	998	1887	1022	1972	1044	2060	1066	2151	1088	2245		
3200 [1510]	581	1044	614	1083	646	1125	677	1170	708	738	1270	768	1324	796	1382	824	1443	852	1503	879	1575	905	1646	931	1719	955	1796	980	1876	1003	1960	1026	2046	1048	2136	1070	2229	1091	2325		
3300 [1557]	594	1093	626	1134	658	1178	689	1225	719	749	1328	778	1384	806	1444	833	1507	860	1567	887	1642	912	1714	937	1790	962	1869	985	1951	1008	2036	1031	2124	1052	2216	1073	2310	1094	2408		
3400 [1604]	607	1146	639	1189	670	1224	701	1283	730	760	1335	788	1448	815	1509	843	1574	869	1642	895	1713	920	1787	944	1864	968	1945	991	2028	1014	2115	1036	2205	1057	2298	1077	2395	1097	2494		
3500 [1652]	621	1203	652	1247	683	1294	713	1344	742	772	1398	806	1465	832	1528	852	1604	878	1714	903	1786	928	1862	952	1941	975	2024	997	2109	1019	2198	1041	2290	1061	2385	1081	2483	1101	2584		
3600 [1699]	635	1262	666	1308	696	1357	725	1409	754	784	1465	782	1523	809	1585	836	1650	862	1718	887	1789	912	1864	936	1941	959	2022	982	2106	1004	2194	1025	2284	1046	2378	1066	2474	1086	2574	1104	2677

NOTE: A/F-Drive left of bold line, B/G-Drive right of bold line, C/H-Drive right of double line.

Drive Package	A/F	B/G	C/H																
Motor H.P. [W]	2 [1491.4]	3 [2237.1]	3 [2237.1]																
Blower Sheave	AK84H	AK84H	AK84H																
Motor Sheave	1V140*7/8	1VP50*7/8	1VP56*7/8																
Belt	A49	A50	A51																
Turns Open	0	1	2	3	4	5	0	1	2	3	4	5	0	1	2	3	4	5	
RPM	765	720	<b>676</b>	633	589	544	989	949	908	865	823	<b>780</b>	740	1108	1067	1029	987	946	<b>905</b>

NOTES: 1. Factory sheave settings are shown in bold type.

2. Do not set motor sheave below minimum or maximum turns open shown.

3. Re-adjustment of sheave required to achieve rated airflow at AHRl minimum External Static Pressure

4. Drive data shown is for horizontal airflow with dry coil. Add component resistance (below) to duct resistance to determine total External Static Pressure.

Airflow	AIRFLOW CORRECTION FACTORS *			Wet Coil			Horizontal Economizer RA Damper Open			Concentric Diffuser RXRN-AEF2000 & Concentric Adapter RXMC-DD01 (Flush)			Concentric Diffuser RXRN-AED2000 & Concentric Adapter RXMC-DD01 (Drop)		
	Total MBH	Sensible MBH	Power kW	Resistance — Inches of Water [kPa]			Resistance — Inches of Water [kPa]			Resistance — Inches of Water [kPa]			Resistance — Inches of Water [kPa]		
	CFM [L/s]	CFM [L/s]	CFM [L/s]	CFM [L/s]	CFM [L/s]	CFM [L/s]	CFM [L/s]	CFM [L/s]	CFM [L/s]	CFM [L/s]	CFM [L/s]	CFM [L/s]	CFM [L/s]	CFM [L/s]	CFM [L/s]
2400 [1133]	0.97	0.92	0.99	0.06	[.01]	0.01	[.00]	0.66	[.16]	0.53	[.13]	0.71	[.18]	0.57	[.14]
2500 [1180]	0.97	0.93	0.99	0.06	[.01]	0.02	[.00]	0.71	[.18]	0.57	[.14]	0.75	[.19]	0.60	[.15]
2600 [1227]	0.98	0.95	0.99	0.06	[.02]	0.02	[.00]	0.75	[.19]	0.65	[.16]	0.80	[.20]	0.65	[.16]
2700 [1274]	0.99	0.96	0.99	0.07	[.02]	0.03	[.01]	0.80	[.20]	0.69	[.17]	0.85	[.21]	0.69	[.17]
2800 [1321]	0.99	0.98	1.00	0.07	[.02]	0.04	[.01]	0.85	[.21]	0.74	[.18]	0.91	[.23]	0.79	[.20]
2900 [1368]	1.00	1.00	1.00	0.08	[.02]	0.04	[.01]	0.91	[.23]	0.86	[.21]	0.96	[.24]	0.86	[.21]
3000 [1416]	1.01	1.01	1.00	0.08	[.02]	0.05	[.01]	0.96	[.24]	0.92	[.23]	1.02	[.25]	0.92	[.23]
3100 [1463]	1.01	1.03	1.00	0.09	[.02]	0.06	[.01]	1.02	[.25]	0.99	[.25]	1.08	[.27]	0.99	[.25]
3200 [1510]	1.02	1.04	1.01	0.10	[.02]	0.07	[.02]	1.08	[.27]	1.05	[.26]	1.15	[.29]	1.05	[.26]
3300 [1557]	1.02	1.06	1.01	0.10	[.03]	0.08	[.02]	1.15	[.29]	1.11	[.27]	1.21	[.30]	1.11	[.27]
3400 [1604]	1.03	1.08	1.01	0.11	[.03]	0.09	[.02]	1.21	[.30]	1.13	[.28]	1.29	[.32]	1.13	[.28]
3500 [1652]	1.04	1.09	1.01	0.11	[.03]	0.10	[.02]	1.29	[.32]	1.16	[.29]	1.36	[.34]	1.16	[.29]
3600 [1699]	1.04	1.11	1.02	0.12	[.03]	0.11	[.03]	1.36	[.34]	1.18	[.29]	1.41	[.35]	1.18	[.29]



# AIRFLOW PERFORMANCE — RHPDZ\*102\*

## AIRFLOW PERFORMANCE — 8.5 TON [29.9kW] — 60 Hz — DOWNFLOW

Model RHPDZ*102*		Voltage 208/230, 460, 575 — 3 phase 60 Hz																																						
Air Flow CFM [L/s]		External Static Pressure — Inches of Water [kPa]																																						
		0.1 [0.02]		0.2 [0.05]		0.3 [0.07]		0.4 [0.10]		0.5 [0.12]		0.6 [0.15]		0.7 [0.17]		0.8 [0.20]		0.9 [0.22]		1.0 [0.25]		1.1 [0.27]		1.2 [0.30]		1.3 [0.32]		1.4 [0.35]		1.5 [0.37]		1.6 [0.40]		1.7 [0.42]		1.8 [0.45]		1.9 [0.47]		2.0 [0.50]
RPM	W	RPM	W	RPM	W	RPM	W	RPM	W	RPM	W	RPM	W	RPM	W	RPM	W	RPM	W	RPM	W	RPM	W	RPM	W	RPM	W	RPM	W	RPM	W	RPM	W	RPM	W	RPM	W			
2700 [1274]	—	561	894	596	934	631	975	665	1018	698	1062	730	1108	762	1155	793	1203	823	1253	853	1304	882	1357	910	1411	937	1467	964	1524	990	1583	1015	1643	1039	1704	1063	1767	1086	1832	
2800 [1321]	—	573	927	608	969	642	1013	676	1058	708	1104	740	1152	771	1201	802	1252	832	1304	861	1358	889	1413	917	1470	943	1528	970	1587	995	1648	1020	1711	1044	1775	1067	1840	1090	1907	
2900 [1368]	—	586	964	620	1008	654	1054	687	1101	719	1150	750	1200	781	1252	811	1305	840	1360	869	1416	897	1473	924	1532	950	1593	976	1654	1001	1718	1025	1782	1048	1848	1071	1916	1093	1985	
3000 [1416]	564	959	599	1004	633	1051	666	1099	698	1149	730	1200	761	1253	791	1307	820	1362	849	1419	877	1477	904	1537	931	1598	957	1661	982	1725	1006	1791	1030	1858	1053	1926	1075	1996	1097	2067
3100 [1463]	578	1001	612	1048	645	1098	678	1148	710	1200	741	1254	771	1308	801	1365	830	1423	858	1482	886	1542	912	1605	939	1668	964	1733	989	1800	1012	1868	1036	1937	1058	2008	1080	2080	1101	2154
3200 [1510]	592	1046	625	1096	658	1148	690	1201	721	1255	752	1311	782	1368	811	1427	840	1487	867	1548	894	1611	921	1676	946	1742	971	1809	995	1878	1019	1948	1041	2020	1063	2093	1085	2168	1105	2244
3300 [1557]	605	1096	638	1148	671	1202	702	1257	733	1314	763	1372	793	1432	821	1493	849	1555	877	1619	903	1684	929	1751	954	1819	979	1889	1002	1960	1025	2033	1047	2107	1069	2182	1090	2259	1110	2337
3400 [1604]	619	1149	652	1204	684	1260	715	1317	745	1376	775	1437	804	1499	832	1562	860	1627	886	1693	912	1761	938	1830	962	1900	986	1972	1009	2046	1032	2121	1053	2197	1074	2275	1095	2354	1114	2435
3500 [1652]	634	1206	666	1263	697	1322	728	1382	758	1443	787	1506	815	1570	843	1635	870	1702	898	1771	922	1841	946	1912	970	1985	994	2060	1017	2135	1038	2213	1060	2291	1080	2371	1100	2453	1119	2536
3600 [1699]	648	1267	680	1326	711	1387	741	1449	770	1513	799	1578	827	1645	854	1713	880	1782	906	1853	931	1925	955	1999	979	2074	1002	2151	1024	2229	1045	2308	1066	2389	1086	2472	1105	2556	1124	2641
3700 [1746]	663	1332	694	1393	724	1456	754	1521	783	1587	811	1654	838	1723	865	1793	891	1865	916	1938	941	2013	965	2089	988	2167	1010	2246	1032	2326	1053	2408	1073	2491	1092	2576	1111	2662	1129	2750
3800 [1793]	678	1400	708	1464	738	1529	767	1596	795	1665	823	1734	850	1805	876	1878	902	1952	926	2028	951	2103	974	2183	996	2263	1018	2344	1039	2427	1060	2511	1080	2597	1099	2684	1117	2772	1134	2862
3900 [1840]	693	1472	723	1538	752	1606	781	1675	808	1746	836	1818	862	1892	888	1966	913	2043	937	2121	951	2200	983	2281	1005	2363	1027	2447	1048	2532	1067	2618	1087	2706	1105	2796	1123	2886	1140	2979
4000 [1888]	708	1548	737	1617	766	1687	794	1758	822	1831	848	1906	874	1981	900	2059	924	2137	948	2218	971	2299	993	2382	1015	2467	1036	2553	1056	2640	1075	2729	1094	2819	1112	2911	1129	3004	1146	3099
4100 [1935]	723	1628	752	1699	781	1771	808	1845	835	1920	861	1997	887	2075	911	2155	935	2236	959	2318	981	2402	1003	2488	1024	2574	1045	2663	1064	2752	1083	2844	1101	2936	1119	3030	1136	3126	1152	3223

NOTE: A/F—Drive left of bold line; B/G—Drive right of bold line; C/H—Drive right of double line.

Drive Package	A/F	B/G	C/H
Motor H.P. [W]	2 [1491.4]	3 [2237.1]	3 [2237.1]
Blower Sheave	AK79H	AK79H	AK79H
Motor Sheave	1V140*7/8	1VP50*7/8	1VP56*7/8
Belt	A49	A50	A51
Turns Open	0	1	2
RPM	804	758	710
		661	616
		559	514
		1048	1003
		959	914
		872	826
		1168	1128
		1087	1044
		1002	1002
		5	5

- NOTES: 1. Factory sheave settings are shown in bold type.  
 2. Do not set motor sheave below minimum or maximum turns open shown.  
 3. Re-adjustment of sheave required to achieve rated airflow at AHR minimum External Static Pressure  
 4. Drive data shown is for vertical airflow with dry coil. Add component resistance (below) to duct resistance to determine total External Static Pressure.

Airflow CFM [L/s]	AIRFLOW CORRECTION FACTORS *			COMPONENT AIRFLOW RESISTANCE		
	Total MBH	Sensible MBH	Power kW	Vertical Economizer RA Damper Open	Wet Coil	Concentric Diffuser RXRN-AEF2000 & Concentric Adapter RXMC-DD01 (Flush)
2700 [1274]	0.99	0.96	0.99	0.03 [0.01]	0.07 [0.02]	0.80 [0.20]
2800 [1321]	0.99	0.98	1.00	0.03 [0.01]	0.07 [0.02]	0.85 [0.21]
2900 [1368]	1.00	1.00	1.00	0.04 [0.01]	0.08 [0.02]	0.91 [0.23]
3000 [1416]	1.01	1.01	1.00	0.05 [0.01]	0.08 [0.02]	0.96 [0.24]
3100 [1463]	1.01	1.03	1.00	0.06 [0.01]	0.09 [0.02]	1.02 [0.25]
3200 [1510]	1.02	1.04	1.01	0.07 [0.02]	0.10 [0.02]	1.08 [0.27]
3300 [1557]	1.02	1.06	1.01	0.08 [0.02]	0.10 [0.02]	1.15 [0.29]
3400 [1604]	1.03	1.08	1.01	0.09 [0.02]	0.11 [0.03]	1.21 [0.30]
3500 [1652]	1.04	1.09	1.01	0.10 [0.02]	0.11 [0.03]	1.29 [0.32]
3600 [1699]	1.04	1.11	1.02	0.11 [0.03]	0.12 [0.03]	1.36 [0.34]
3700 [1746]	1.05	1.12	1.02	0.12 [0.03]	0.13 [0.03]	1.43 [0.29]
3800 [1793]	1.05	1.14	1.02	0.13 [0.03]	0.13 [0.03]	1.50 [0.37]
3900 [1840]	1.06	1.16	1.02	0.14 [0.03]	0.15 [0.04]	1.59 [0.40]
4000 [1888]	1.07	1.17	1.02	0.16 [0.04]	0.15 [0.04]	1.68 [0.42]
4100 [1935]	1.07	1.19	1.03	0.17 [0.04]	0.15 [0.04]	1.74 [0.43]

\* Multiply correction factor times gross performance data — resulting sensible capacity cannot exceed total capacity. [ ] Designates Metric Conversions

# AIRFLOW PERFORMANCE – RHPDZ\*102\*

## AIRFLOW PERFORMANCE — 8.5 TON [29.9kW] — 60 Hz — SIDEFLOW

**Model RHPDZ\*102\* Voltage 208/230, 460, 575 — 3 phase 60 Hz**

Air Flow CFM [L/s]	External Static Pressure — Inches of Water [kPa]																																										
	0.1 [0.02]		0.2 [0.05]		0.3 [0.07]		0.4 [0.10]		0.5 [0.12]		0.6 [0.15]		0.7 [0.17]		0.8 [0.20]		0.9 [0.22]		1.1 [0.29]		1.2 [0.30]		1.3 [0.32]		1.4 [0.35]		1.5 [0.37]		1.6 [0.40]		1.7 [0.42]		1.8 [0.45]		1.9 [0.47]		2.0 [0.50]						
	RPM	W	RPM	W	RPM	W	RPM	W	RPM	W	RPM	W	RPM	W	RPM	W	RPM	W	RPM	W	RPM	W	RPM	W	RPM	W	RPM	W	RPM	W	RPM	W	RPM	W	RPM	W	RPM	W	RPM	W	RPM	W	RPM
2700 [1274]	—	—	—	—	—	577	932	611	989	644	1009	677	1052	710	1088	742	1147	774	1189	806	1254	837	1312	868	1373	898	1437	929	1505	959	1575	988	1648	1017	1725	1046	1804	1074	1886	1102	1972		
2800 [1321]	—	—	—	—	556	926	589	962	622	1000	655	1042	687	1087	719	1134	751	1185	783	1239	814	1295	844	1355	875	1418	905	1484	934	1553	963	1624	992	1699	1021	1777	1049	1858	1077	1942	1105	2029	
2900 [1368]	—	—	—	—	568	958	601	995	633	1036	666	1079	697	1125	729	1174	760	1227	791	1282	821	1340	851	1402	881	1466	911	1533	940	1604	968	1677	997	1754	1025	1834	1052	1916	1080	2002	1107	2090	
3000 [1416]	—	—	—	—	580	994	613	1033	645	1074	676	1119	708	1167	738	1218	767	1272	799	1329	829	1389	859	1452	888	1518	917	1587	945	1659	973	1734	1001	1812	1029	1894	1056	1978	1082	2065	1109	2155	
3100 [1463]	561	986	593	1033	624	1073	656	1117	687	1163	718	1213	748	1265	778	1321	808	1379	837	1441	866	1506	895	1573	923	1644	951	1718	978	1794	1006	1874	1033	1957	1059	2043	1085	2132	1111	2224			
3200 [1510]	574	1037	605	1076	636	1118	667	1163	698	1211	728	1262	758	1316	787	1373	816	1434	845	1497	873	1563	902	1632	929	1705	957	1780	984	1858	1010	1940	1037	2024	1063	2112	1088	2202	1113	2296			
3300 [1557]	587	1082	618	1122	648	1166	679	1212	709	1262	738	1315	767	1371	796	1430	825	1491	853	1556	881	1624	908	1695	936	1769	962	1846	989	1926	1015	2009	1041	2095	1066	2184	1091	2276	1116	2372			
3400 [1604]	600	1130	630	1172	660	1217	690	1266	720	1317	749	1371	777	1429	806	1489	834	1553	861	1619	888	1689	915	1761	942	1837	968	1916	994	1997	1020	2082	1045	2170	1070	2260	1094	2354	1118	2451			
3500 [1652]	613	1182	643	1226	672	1273	702	1323	730	1376	759	1432	787	1491	815	1553	842	1618	869	1686	896	1757	922	1831	948	1909	974	1989	999	2072	1024	2168	1049	2248	1073	2340	1097	2436	1121	2534			
3600 [1699]	626	1238	656	1283	685	1332	713	1383	741	1438	769	1495	797	1556	824	1620	851	1687	877	1756	904	1829	929	1905	955	1984	980	2066	1005	2151	1029	2238	1053	2329	1077	2423	1103	2520	1128	2621			
3700 [1746]	640	1297	668	1344	697	1394	725	1447	753	1504	780	1563	807	1625	833	1690	860	1759	886	1830	911	1905	937	1982	961	2063	986	2146	1010	2233	1034	2322	1057	2415	1081	2510	1103	2608	1126	2711			
3800 [1793]	653	1360	681	1409	709	1460	737	1515	764	1573	790	1634	817	1698	843	1765	869	1835	894	1908	919	1984	944	2063	968	2145	992	2230	1016	2318	1039	2410	1062	2504	1084	2601	1107	2701	1128	2805			
3900 [1840]	667	1426	694	1477	721	1530	748	1567	775	1646	801	1709	827	1774	852	1843	878	1914	902	1988	927	2067	951	2147	975	2231	998	2318	1021	2408	1044	2500	1066	2596	1088	2696	1110	2797	1131	2902			
4000 [1888]	680	1496	707	1548	734	1604	760	1662	786	1723	812	1787	837	1854	862	1924	887	1988	911	2074	935	2153	958	2235	981	2321	1004	2409	1027	2501	1049	2596	1071	2693	1092	2793	1113	2897	1134	3003			
4100 [1935]	694	1570	720	1624	746	1681	772	1740	797	1803	822	1869	847	1938	872	1998	896	2064	919	2162	943	2243	965	2327	988	2414	1010	2504	1032	2597	1054	2693	1075	2792	1096	2896	1116	3000	1137	3108			

NOTE: A/F-Drive left of bold line, B/G-Drive right of bold line, C/H-Drive right of double line.

Drive Package	A/F										B/G										C/H									
Motor H.P. [W]	<b>2 [1491.4]</b>										<b>3 [2237.1]</b>										<b>3 [2237.1]</b>									
Blower Sheave	AK79H										AK79H										AK79H									
Motor Sheave	1V140*7/8										1VP50*7/8										1VP56*7/8									
Belt	A49										A50										A51									
Turns Open	0	1	2	3	4	5	6	7	8	9	0	1	2	3	4	5	6	7	8	9	0	1	2	3	4	5	6	7	8	9
RPM	802	754	707	662	616	555	1048	960	916	870	827	780	733	687	641	595	1170	1126	1085	1044	1000	956	912	868	824	780	736	692	648	604

- NOTES: 1. Factory sheave settings are shown in bold type.  
 2. Do not set motor sheave below minimum or maximum turns open shown.  
 3. Re-adjustment of sheave required to achieve rated airflow at AHR minimum External Static Pressure  
 4. Drive data shown is for horizontal airflow with dry coil. Add component resistance (below) to duct resistance to determine total External Static Pressure.

Airflow	AIRFLOW CORRECTION FACTORS *		COMPONENT AIRFLOW RESISTANCE				
	Total MBH	Sensible MBH	Power kW	Wet Coil	Horizontal Economizer RA Damper Open	Concentric Diffuser RXRN-AEF2000 & Concentric Adapter RXMC-DD01 (Flush)	Concentric Diffuser RXRN-AED2000 & Concentric Adapter RXMC-DD01 (Drop)
2700 [1274]	0.99	0.96	0.99	0.07 [0.02]	0.03 [0.01]	0.80 [0.20]	0.65 [0.16]
2800 [1321]	0.99	0.98	1.00	0.07 [0.02]	0.03 [0.01]	0.85 [0.21]	0.69 [0.17]
2900 [1368]	1.00	1.00	1.00	0.08 [0.02]	0.04 [0.01]	0.91 [0.23]	0.74 [0.18]
3000 [1416]	1.01	1.01	1.00	0.08 [0.02]	0.05 [0.01]	0.96 [0.24]	0.79 [0.20]
3100 [1463]	1.01	1.03	1.00	0.09 [0.02]	0.06 [0.01]	1.02 [0.25]	0.86 [0.21]
3200 [1510]	1.02	1.04	1.01	0.07 [0.02]	0.07 [0.02]	1.08 [0.27]	0.92 [0.23]
3300 [1557]	1.02	1.06	1.01	0.10 [0.03]	0.08 [0.02]	1.15 [0.29]	0.99 [0.25]
3400 [1604]	1.03	1.08	1.01	0.11 [0.03]	0.09 [0.02]	1.21 [0.30]	1.05 [0.26]
3500 [1652]	1.04	1.09	1.01	0.11 [0.03]	0.10 [0.02]	1.29 [0.32]	1.09 [0.27]
3600 [1699]	1.04	1.11	1.02	0.12 [0.03]	0.11 [0.03]	1.36 [0.34]	1.13 [0.28]
3700 [1746]	1.05	1.12	1.02	0.13 [0.03]	0.12 [0.03]	1.43 [0.36]	1.18 [0.29]
3800 [1793]	1.05	1.14	1.02	0.13 [0.03]	0.13 [0.03]	1.50 [0.37]	1.23 [0.31]
3900 [1840]	1.06	1.16	1.02	0.14 [0.04]	0.15 [0.04]	1.59 [0.40]	1.31 [0.33]
4000 [1888]	1.07	1.17	1.02	0.15 [0.04]	0.16 [0.04]	1.68 [0.42]	1.38 [0.34]
4100 [1935]	1.07	1.19	1.03	0.15 [0.04]	0.17 [0.04]	1.74 [0.43]	1.44 [0.36]

\* Multiply correction factor times gross performance data — resulting sensible capacity cannot exceed total capacity. [ ] Designates Metric Conversions







**XX. HEATER KIT CHARACTERISTICS FOR  
TABLE 2. AUXILIARY HEATER KITS CHARACTERISTICS AND APPLICATION**

208/240 VOLT, THREE PHASE, 60 Hz, AUXILIARY ELECTRIC HEATER KITS CHARACTERISTICS AND APPLICATION														
Single Power Supply for Both Unit and Heater Kit														
RHEEM Model Number	RXJ- Heater Kit Nominal kW	No. of Sequence Steps	Heater Kit				Heat Pump				Separate Power Supply for Both Unit and Heater Kit			
			Rated Heater kW @ 208/240 V	Heater kBTU/Hr @ 208/240 V	Heater Amp. @ 208/240 V	Unit Min. Ckt. Ampacity @ 208/240 V	Over Current Protective Device Size		Min. Circuit Ampacity 208/240V	Max. Fuse Size 208/240V	Min. Circuit Ampacity 208/240V	Over Current Protective Device Size		
							Min./Max. @ 208 V	Min./Max. @ 240 V				Min./Max. @ 208 V	Min./Max. @ 240 V	
RHPDZR090ACA	No Heat	-----	-----	-----	-----	43/43	50/60	50/60	-----	43/43	50/60	50/60	50/60	
	DD10CP	1	7.4/9.9	25.25/33.78	20.6/23.8	69/73	80/80	80/90	26/30	43/43	50/60	50/60	50/60	
	DD15CP	1	10.8/14.4	36.85/49.13	30.0/34.6	81/87	90/90	90/100	38/44	43/43	50/60	50/60	50/60	
	DD20CP	1	14.9/19.8	50.84/67.56	41.3/47.6	95/103	100/100	110/110	52/60	43/43	50/60	50/60	50/60	
	DD30CP	1	21.6/28.8	73.70/98.27	60.0/69.3	118/130	125/125	150/150	75/87	43/43	50/60	50/60	50/60	
	DD40CP	1	29.7/39.6	101.34/135.12	82.5/95.2	146/162	150/150	175/175	104/119	43/43	50/60	50/60	50/60	
RHPDZR090ACB	No Heat	-----	-----	-----	-----	46/46	60/70	60/70	-----	46/46	60/70	60/70	60/70	
	DD10CP	1	7.4/9.9	25.25/33.78	20.6/23.8	72/76	80/90	80/90	26/30	46/46	60/70	60/70	60/70	
	DD15CP	1	10.8/14.4	36.85/49.13	30.0/34.6	83/89	90/100	100/100	38/44	46/46	60/70	60/70	60/70	
	DD20CP	1	14.9/19.8	50.84/67.56	41.3/47.6	97/105	110/110	110/110	52/60	46/46	60/70	60/70	60/70	
	DD30CP	1	21.6/28.8	73.70/98.27	60.0/69.3	121/132	125/125	150/150	75/87	46/46	60/70	60/70	60/70	
	DD40CP	1	29.7/39.6	101.34/135.12	82.5/95.2	149/165	175/175	175/175	104/119	46/46	60/70	60/70	60/70	
RHPDZR090ACC	No Heat	-----	-----	-----	-----	46/46	60/70	60/70	-----	46/46	60/70	60/70	60/70	
	DD10CP	1	7.4/9.9	25.25/33.78	20.6/23.8	72/76	80/90	80/90	26/30	46/46	60/70	60/70	60/70	
	DD15CP	1	10.8/14.4	36.85/49.13	30.0/34.6	83/89	90/100	100/100	38/44	46/46	60/70	60/70	60/70	
	DD20CP	1	14.9/19.8	50.84/67.56	41.3/47.6	97/105	110/110	110/110	52/60	46/46	60/70	60/70	60/70	
	DD30CP	1	21.6/28.8	73.70/98.27	60.0/69.3	121/132	125/125	150/150	75/87	46/46	60/70	60/70	60/70	
	DD40CP	1	29.7/39.6	101.34/135.12	82.5/95.2	149/165	175/175	175/175	104/119	46/46	60/70	60/70	60/70	
RHPDZR102ACA	No Heat	-----	-----	-----	-----	47/47	60/70	60/70	-----	47/47	60/70	60/70	60/70	
	DD10CP	1	7.4/9.9	25.25/33.78	20.6/23.8	73/77	80/90	80/90	26/30	47/47	60/70	60/70	60/70	
	DD15CP	1	10.8/14.4	36.85/49.13	30.0/34.6	84/90	90/100	100/100	38/44	47/47	60/70	60/70	60/70	
	DD20CP	1	14.9/19.8	50.84/67.56	41.3/47.6	99/106	110/110	110/110	52/60	47/47	60/70	60/70	60/70	
	DD30CP	1	21.6/28.8	73.70/98.27	60.0/69.3	122/134	125/125	150/150	75/87	47/47	60/70	60/70	60/70	
	DD40CP	1	29.7/39.6	101.34/135.12	82.5/95.2	150/166	175/175	175/175	104/119	47/47	60/70	60/70	60/70	
RHPDZR102ACB	No Heat	-----	-----	-----	-----	49/49	60/70	60/70	-----	49/49	60/70	60/70	60/70	
	DD10CP	1	7.4/9.9	25.25/33.78	20.6/23.8	75/79	80/90	90/90	26/30	49/49	60/70	60/70	60/70	
	DD15CP	1	10.8/14.4	36.85/49.13	30.0/34.6	86/92	90/100	100/110	38/44	49/49	60/70	60/70	60/70	



RHPDZS090ACB	No Heat	-----	-----	-----	-----	46/46	60/70	60/70	-----	46/46	60/70	60/70
	DD10CP	1	7.4/9.9	25.25/33.78	20.6/23.8	72/76	80/90	80/90	26/30	46/46	60/70	60/70
	DD15CP	1	10.8/14.4	36.85/49.13	30.0/34.6	84/89	90/100	100/100	38/44	46/46	60/70	60/70
	DD20CP	1	14.9/19.8	50.84/67.56	41.3/47.6	98/106	110/110	110/110	52/60	46/46	60/70	60/70
	DD30CP	1	21.6/28.8	73.70/98.27	60.0/69.3	121/133	125/125	150/150	75/87	46/46	60/70	60/70
	DD40CP	1	29.7/39.6	101.34/135.12	82.5/95.2	149/165	175/175	175/175	104/119	46/46	60/70	60/70
RHPDZS090ACC	No Heat	-----	-----	-----	-----	46/46	60/70	60/70	-----	46/46	60/70	60/70
	DD10CP	1	7.4/9.9	25.25/33.78	20.6/23.8	72/76	80/90	80/90	26/30	46/46	60/70	60/70
	DD15CP	1	10.8/14.4	36.85/49.13	30.0/34.6	84/89	90/100	100/100	38/44	46/46	60/70	60/70
	DD20CP	1	14.9/19.8	50.84/67.56	41.3/47.6	98/106	110/110	110/110	52/60	46/46	60/70	60/70
	DD30CP	1	21.6/28.8	73.70/98.27	60.0/69.3	121/133	125/125	150/150	75/87	46/46	60/70	60/70
	DD40CP	1	29.7/39.6	101.34/135.12	82.5/95.2	149/165	175/175	175/175	104/119	46/46	60/70	60/70
RHPDZS090ACF	No Heat	-----	-----	-----	-----	44/44	50/60	50/60	-----	44/44	50/60	50/60
	DD10CP	1	7.4/9.9	25.25/33.78	20.6/23.8	69/73	80/80	80/90	26/30	44/44	50/60	50/60
	DD15CP	1	10.8/14.4	36.85/49.13	30.0/34.6	81/87	90/90	90/100	38/44	44/44	50/60	50/60
	DD20CP	1	14.9/19.8	50.84/67.56	41.3/47.6	95/103	100/100	110/110	52/60	44/44	50/60	50/60
	DD30CP	1	21.6/28.8	73.70/98.27	60.0/69.3	119/130	125/125	150/150	75/87	44/44	50/60	50/60
	DD40CP	1	29.7/39.6	101.34/135.12	82.5/95.2	147/163	150/150	175/175	104/119	44/44	50/60	50/60
RHPDZS090ACG	No Heat	-----	-----	-----	-----	46/46	60/70	60/70	-----	46/46	60/70	60/70
	DD10CP	1	7.4/9.9	25.25/33.78	20.6/23.8	72/76	80/90	80/90	26/30	46/46	60/70	60/70
	DD15CP	1	10.8/14.4	36.85/49.13	30.0/34.6	84/89	90/100	100/100	38/44	46/46	60/70	60/70
	DD20CP	1	14.9/19.8	50.84/67.56	41.3/47.6	98/106	110/110	110/110	52/60	46/46	60/70	60/70
	DD30CP	1	21.6/28.8	73.70/98.27	60.0/69.3	121/133	125/125	150/150	75/87	46/46	60/70	60/70
	DD40CP	1	29.7/39.6	101.34/135.12	82.5/95.2	149/165	175/175	175/175	104/119	46/46	60/70	60/70
RHPDZS090ACH	No Heat	-----	-----	-----	-----	46/46	60/70	60/70	-----	46/46	60/70	60/70
	DD10CP	1	7.4/9.9	25.25/33.78	20.6/23.8	72/76	80/90	80/90	26/30	46/46	60/70	60/70
	DD15CP	1	10.8/14.4	36.85/49.13	30.0/34.6	84/89	90/100	100/100	38/44	46/46	60/70	60/70
	DD20CP	1	14.9/19.8	50.84/67.56	41.3/47.6	98/106	110/110	110/110	52/60	46/46	60/70	60/70
	DD30CP	1	21.6/28.8	73.70/98.27	60.0/69.3	121/133	125/125	150/150	75/87	46/46	60/70	60/70
	DD40CP	1	29.7/39.6	101.34/135.12	82.5/95.2	149/165	175/175	175/175	104/119	46/46	60/70	60/70
RHPDZS102ACA	No Heat	-----	-----	-----	-----	48/48	60/70	60/70	-----	48/48	60/70	60/70
	DD10CP	1	7.4/9.9	25.25/33.78	20.6/23.8	74/78	80/90	90/100	26/30	48/48	60/70	60/70



	DD40CP	1	29.7/39.6	101.34/135.12	82.5/95.2	157/172	175/175	200/200	104/119	110/125	53/53	70/80	70/80
RHPDZS120ACA	No Heat	-----	-----	-----	-----	54/54	70/80	70/80	-----	-----	54/54	70/80	70/80
	DD10CP	1	7.4/9.9	25.25/33.78	20.6/23.8	80/84	90/100	90/100	26/30	30/30	54/54	70/80	70/80
	DD15CP	1	10.8/14.4	36.85/49.13	30.0/34.6	91/97	100/110	100/110	38/44	40/45	54/54	70/80	70/80
	DD20CP	1	14.9/19.8	50.84/67.56	41.3/47.6	106/113	110/125	125/125	52/60	60/60	54/54	70/80	70/80
	DD30CP	1	21.6/28.8	73.70/98.27	60.0/69.3	129/141	150/150	150/150	75/87	80/90	54/54	70/80	70/80
	DD40CP	1	29.7/39.6	101.34/135.12	82.5/95.2	157/173	175/175	200/200	104/119	110/125	54/54	70/80	70/80
RHPDZS120ACB	No Heat	-----	-----	-----	-----	57/57	70/80	70/80	-----	-----	57/57	70/80	70/80
	DD10CP	1	7.4/9.9	25.25/33.78	20.6/23.8	82/86	90/100	90/110	26/30	30/30	57/57	70/80	70/80
	DD15CP	1	10.8/14.4	36.85/49.13	30.0/34.6	94/100	100/110	110/110	38/44	40/45	57/57	70/80	70/80
	DD20CP	1	14.9/19.8	50.84/67.56	41.3/47.6	108/116	125/125	125/125	52/60	60/60	57/57	70/80	70/80
	DD30CP	1	21.6/28.8	73.70/98.27	60.0/69.3	132/143	150/150	150/150	75/87	80/90	57/57	70/80	70/80
	DD40CP	1	29.7/39.6	101.34/135.12	82.5/95.2	160/176	175/175	200/200	104/119	110/125	57/57	70/80	70/80
RHPDZS120ACC	No Heat	-----	-----	-----	-----	58/58	70/90	70/90	-----	-----	58/58	70/90	70/90
	DD10CP	1	7.4/9.9	25.25/33.78	20.6/23.8	84/88	90/110	100/110	26/30	30/30	58/58	70/90	70/90
	DD15CP	1	10.8/14.4	36.85/49.13	30.0/34.6	96/101	100/110	110/110	38/44	40/45	58/58	70/90	70/90
	DD20CP	1	14.9/19.8	50.84/67.56	41.3/47.6	110/118	125/125	125/125	52/60	60/60	58/58	70/90	70/90
	DD30CP	1	21.6/28.8	73.70/98.27	60.0/69.3	133/145	150/150	150/150	75/87	80/90	58/58	70/90	70/90
	DD40CP	1	29.7/39.6	101.34/135.12	82.5/95.2	161/177	175/175	200/200	104/119	110/125	58/58	70/90	70/90
RHPDZS120ACF	No Heat	-----	-----	-----	-----	54/54	70/80	70/80	-----	-----	54/54	70/80	70/80
	DD10CP	1	7.4/9.9	25.25/33.78	20.6/23.8	80/84	90/100	90/100	26/30	30/30	54/54	70/80	70/80
	DD15CP	1	10.8/14.4	36.85/49.13	30.0/34.6	91/97	100/110	100/110	38/44	40/45	54/54	70/80	70/80
	DD20CP	1	14.9/19.8	50.84/67.56	41.3/47.6	106/113	110/125	125/125	52/60	60/60	54/54	70/80	70/80
	DD30CP	1	21.6/28.8	73.70/98.27	60.0/69.3	129/141	150/150	150/150	75/87	80/90	54/54	70/80	70/80
	DD40CP	1	29.7/39.6	101.34/135.12	82.5/95.2	157/173	175/175	200/200	104/119	110/125	54/54	70/80	70/80
RHPDZS120ACG	No Heat	-----	-----	-----	-----	57/57	70/80	70/80	-----	-----	57/57	70/80	70/80
	DD10CP	1	7.4/9.9	25.25/33.78	20.6/23.8	82/86	90/100	90/110	26/30	30/30	57/57	70/80	70/80
	DD15CP	1	10.8/14.4	36.85/49.13	30.0/34.6	94/100	100/110	110/110	38/44	40/45	57/57	70/80	70/80
	DD20CP	1	14.9/19.8	50.84/67.56	41.3/47.6	108/116	125/125	125/125	52/60	60/60	57/57	70/80	70/80
	DD30CP	1	21.6/28.8	73.70/98.27	60.0/69.3	132/143	150/150	150/150	75/87	80/90	57/57	70/80	70/80
	DD40CP	1	29.7/39.6	101.34/135.12	82.5/95.2	160/176	175/175	200/200	104/119	110/125	57/57	70/80	70/80
RHPDZS120ACH	No Heat	-----	-----	-----	-----	58/58	70/90	70/90	-----	-----	58/58	70/90	70/90







**480 VOLT, THREE PHASE, 60 Hz, AUXILIARY ELECTRIC HEATER KITS CHARACTERISTICS AND APPLICATION**

Single Power Supply for Both Unit and Heater Kit										Separate Power Supply for Both Unit and Heater Kit							
RHEEM Model Number	Heater Kit					Heat Pump					Heater Kit					Heat Pump	
	RXJ- Heater Kit Nominal kW	No. of Sequence Steps	Rated Heater kW @ 480 V	Heater KBTU/Hr @ 480 V	Heater Amp. @ 480 V	Unit Min. Ckt. Ampacity @ 480 V	Over Current Protective Device Size Min./Max. @ 480 V	Min. Ckt. Ampacity 480V	Max. Fuse Size 480V	Min. Circuit Ampacity 480V	Over Current Protective Device Size Min./Max. @ 480 V	Over Current Protective Device Size	Min. Circuit Ampacity 480V	Max. Fuse Size 480V	Min. Ckt. Ampacity 480V	Over Current Protective Device Size	
RHPDZR090ADA	No Heat	-----	-----	-----	-----	23	30/35	-----	-----	23	-----	-----	-----	-----	-----	-----	
	DD10DNNV	1	9.9	33.78	11.9	38	40/45	-----	-----	23	-----	-----	-----	-----	-----	-----	
	DD15DNNV	1	14.4	49.13	17.3	44	50/50	-----	-----	23	-----	-----	-----	-----	-----	-----	
	DD20DNNV	1	19.8	67.56	23.8	52	60/60	-----	-----	23	-----	-----	-----	-----	-----	-----	
	DD30DNNV	1	28.8	98.27	34.6	66	70/70	-----	-----	23	-----	-----	-----	-----	-----	-----	
	DD40DNNV	1	39.6	135.12	47.6	82	90/90	-----	-----	23	-----	-----	-----	-----	-----	-----	
RHPDZR090ADB	No Heat	-----	-----	-----	-----	24	30/35	-----	-----	24	-----	-----	-----	-----	-----	-----	
	DD10DNNV	1	9.9	33.78	11.9	39	45/45	-----	-----	24	-----	-----	-----	-----	-----	-----	
	DD15DNNV	1	14.4	49.13	17.3	46	50/50	-----	-----	24	-----	-----	-----	-----	-----	-----	
	DD20DNNV	1	19.8	67.56	23.8	54	60/60	-----	-----	24	-----	-----	-----	-----	-----	-----	
	DD30DNNV	1	28.8	98.27	34.6	67	70/70	-----	-----	24	-----	-----	-----	-----	-----	-----	
	DD40DNNV	1	39.6	135.12	47.6	84	90/90	-----	-----	24	-----	-----	-----	-----	-----	-----	
RHPDZR090ADC	No Heat	-----	-----	-----	-----	24	30/35	-----	-----	24	-----	-----	-----	-----	-----	-----	
	DD10DNNV	1	9.9	33.78	11.9	39	45/45	-----	-----	24	-----	-----	-----	-----	-----	-----	
	DD15DNNV	1	14.4	49.13	17.3	46	50/50	-----	-----	24	-----	-----	-----	-----	-----	-----	
	DD20DNNV	1	19.8	67.56	23.8	54	60/60	-----	-----	24	-----	-----	-----	-----	-----	-----	
	DD30DNNV	1	28.8	98.27	34.6	67	70/70	-----	-----	24	-----	-----	-----	-----	-----	-----	
	DD40DNNV	1	39.6	135.12	47.6	84	90/90	-----	-----	24	-----	-----	-----	-----	-----	-----	
RHPDZR102ADA	No Heat	-----	-----	-----	-----	23	30/35	-----	-----	23	-----	-----	-----	-----	-----	-----	
	DD10DNNV	1	9.9	33.78	11.9	38	40/45	-----	-----	23	-----	-----	-----	-----	-----	-----	
	DD15DNNV	1	14.4	49.13	17.3	45	50/50	-----	-----	23	-----	-----	-----	-----	-----	-----	
	DD20DNNV	1	19.8	67.56	23.8	53	60/60	-----	-----	23	-----	-----	-----	-----	-----	-----	
	DD30DNNV	1	28.8	98.27	34.6	66	70/70	-----	-----	23	-----	-----	-----	-----	-----	-----	
	DD40DNNV	1	39.6	135.12	47.6	82	90/90	-----	-----	23	-----	-----	-----	-----	-----	-----	
RHPDZR102ADB	No Heat	-----	-----	-----	-----	24	30/35	-----	-----	24	-----	-----	-----	-----	-----	-----	
	DD10DNNV	1	9.9	33.78	11.9	39	45/45	-----	-----	24	-----	-----	-----	-----	-----	-----	



	DD40DNNV	1	39.6	135.12	47.6	78	80/80	60	60	19	25/25	*****
RHPDZS090ADB	No Heat	*****	*****	*****	*****	20	25/25	*****	*****	20	25/25	*****
	DD10DNNV	1	9.9	33.78	11.9	35	40/40	15	15	20	25/25	*****
	DD15DNNV	1	14.4	49.13	17.3	42	45/45	22	25	20	25/25	*****
	DD20DNNV	1	19.8	67.56	23.8	50	60/60	30	30	20	25/25	*****
	DD30DNNV	1	28.8	98.27	34.6	63	70/70	44	45	20	25/25	*****
	DD40DNNV	1	39.6	135.12	47.6	80	90/90	60	60	20	25/25	*****
RHPDZS090ADC	No Heat	*****	*****	*****	*****	20	25/25	*****	*****	20	25/25	*****
	DD10DNNV	1	9.9	33.78	11.9	35	40/40	15	15	20	25/25	*****
	DD15DNNV	1	14.4	49.13	17.3	42	45/45	22	25	20	25/25	*****
	DD20DNNV	1	19.8	67.56	23.8	50	60/60	30	30	20	25/25	*****
	DD30DNNV	1	28.8	98.27	34.6	63	70/70	44	45	20	25/25	*****
	DD40DNNV	1	39.6	135.12	47.6	80	90/90	60	60	20	25/25	*****
RHPDZS090ADF	No Heat	*****	*****	*****	*****	19	25/25	*****	*****	19	25/25	*****
	DD10DNNV	1	9.9	33.78	11.9	34	35/35	15	15	19	25/25	*****
	DD15DNNV	1	14.4	49.13	17.3	40	45/45	22	25	19	25/25	*****
	DD20DNNV	1	19.8	67.56	23.8	48	50/50	30	30	19	25/25	*****
	DD30DNNV	1	28.8	98.27	34.6	62	70/70	44	45	19	25/25	*****
	DD40DNNV	1	39.6	135.12	47.6	78	80/80	60	60	19	25/25	*****
RHPDZS090ADG	No Heat	*****	*****	*****	*****	20	25/25	*****	*****	20	25/25	*****
	DD10DNNV	1	9.9	33.78	11.9	35	40/40	15	15	20	25/25	*****
	DD15DNNV	1	14.4	49.13	17.3	42	45/45	22	25	20	25/25	*****
	DD20DNNV	1	19.8	67.56	23.8	50	60/60	30	30	20	25/25	*****
	DD30DNNV	1	28.8	98.27	34.6	63	70/70	44	45	20	25/25	*****
	DD40DNNV	1	39.6	135.12	47.6	80	90/90	60	60	20	25/25	*****
RHPDZS090ADH	No Heat	*****	*****	*****	*****	20	25/25	*****	*****	20	25/25	*****
	DD10DNNV	1	9.9	33.78	11.9	35	40/40	15	15	20	25/25	*****
	DD15DNNV	1	14.4	49.13	17.3	42	45/45	22	25	20	25/25	*****
	DD20DNNV	1	19.8	67.56	23.8	50	60/60	30	30	20	25/25	*****
	DD30DNNV	1	28.8	98.27	34.6	63	70/70	44	45	20	25/25	*****
	DD40DNNV	1	39.6	135.12	47.6	80	90/90	60	60	20	25/25	*****
RHPDZS102ADA	No Heat	*****	*****	*****	*****	23	30/30	*****	*****	23	30/30	*****









	DD20DNV	1	19.8	67.56	23.8	53	60/60	30	30	30	24	30/35	.....
	DD30DNV	1	28.8	98.27	34.6	67	70/70	44	45	44	24	30/35	.....
	DD40DNV	1	39.6	135.12	47.6	83	90/90	60	60	60	24	30/35	.....
	No Heat	.....	.....	.....	.....	25	30/35	.....	.....	.....	25	30/35	.....
RHPDZT102ADH	DD10DNV	1	9.9	33.78	11.9	40	45/45	15	15	15	25	30/35	.....
	DD15DNV	1	14.4	49.13	17.3	47	50/50	22	25	25	25	30/35	.....
	DD20DNV	1	19.8	67.56	23.8	55	60/60	30	30	30	25	30/35	.....
	DD30DNV	1	28.8	98.27	34.6	68	80/80	44	45	45	25	30/35	.....
	DD40DNV	1	39.6	135.12	47.6	85	90/90	60	60	60	25	30/35	.....
	No Heat	.....	.....	.....	.....	26	35/40	.....	.....	.....	26	35/40	.....
RHPDZT120ADF	DD10DNV	1	9.9	33.78	11.9	41	45/50	15	15	15	26	35/40	.....
	DD15DNV	1	14.4	49.13	17.3	48	50/50	22	25	25	26	35/40	.....
	DD20DNV	1	19.8	67.56	23.8	56	60/60	30	30	30	26	35/40	.....
	DD30DNV	1	28.8	98.27	34.6	69	80/80	44	45	45	26	35/40	.....
	DD40DNV	1	39.6	135.12	47.6	85	90/90	60	60	60	26	35/40	.....
	No Heat	.....	.....	.....	.....	27	35/45	.....	.....	.....	27	35/45	.....
RHPDZT120ADG	DD10DNV	1	9.9	33.78	11.9	42	45/50	15	15	15	27	35/45	.....
	DD15DNV	1	14.4	49.13	17.3	49	60/60	22	25	25	27	35/45	.....
	DD20DNV	1	19.8	67.56	23.8	57	60/60	30	30	30	27	35/45	.....
	DD30DNV	1	28.8	98.27	34.6	70	80/80	44	45	45	27	35/45	.....
	DD40DNV	1	39.6	135.12	47.6	87	90/90	60	60	60	27	35/45	.....
	No Heat	.....	.....	.....	.....	28	35/40	.....	.....	.....	28	35/40	.....
RHPDZT120ADH	DD10DNV	1	9.9	33.78	11.9	43	45/50	15	15	15	28	35/40	.....
	DD15DNV	1	14.4	49.13	17.3	50	60/60	22	25	25	28	35/40	.....
	DD20DNV	1	19.8	67.56	23.8	58	60/60	30	30	30	28	35/40	.....
	DD30DNV	1	28.8	98.27	34.6	71	80/80	44	45	45	28	35/40	.....
	DD40DNV	1	39.6	135.12	47.6	87	90/90	60	60	60	28	35/40	.....

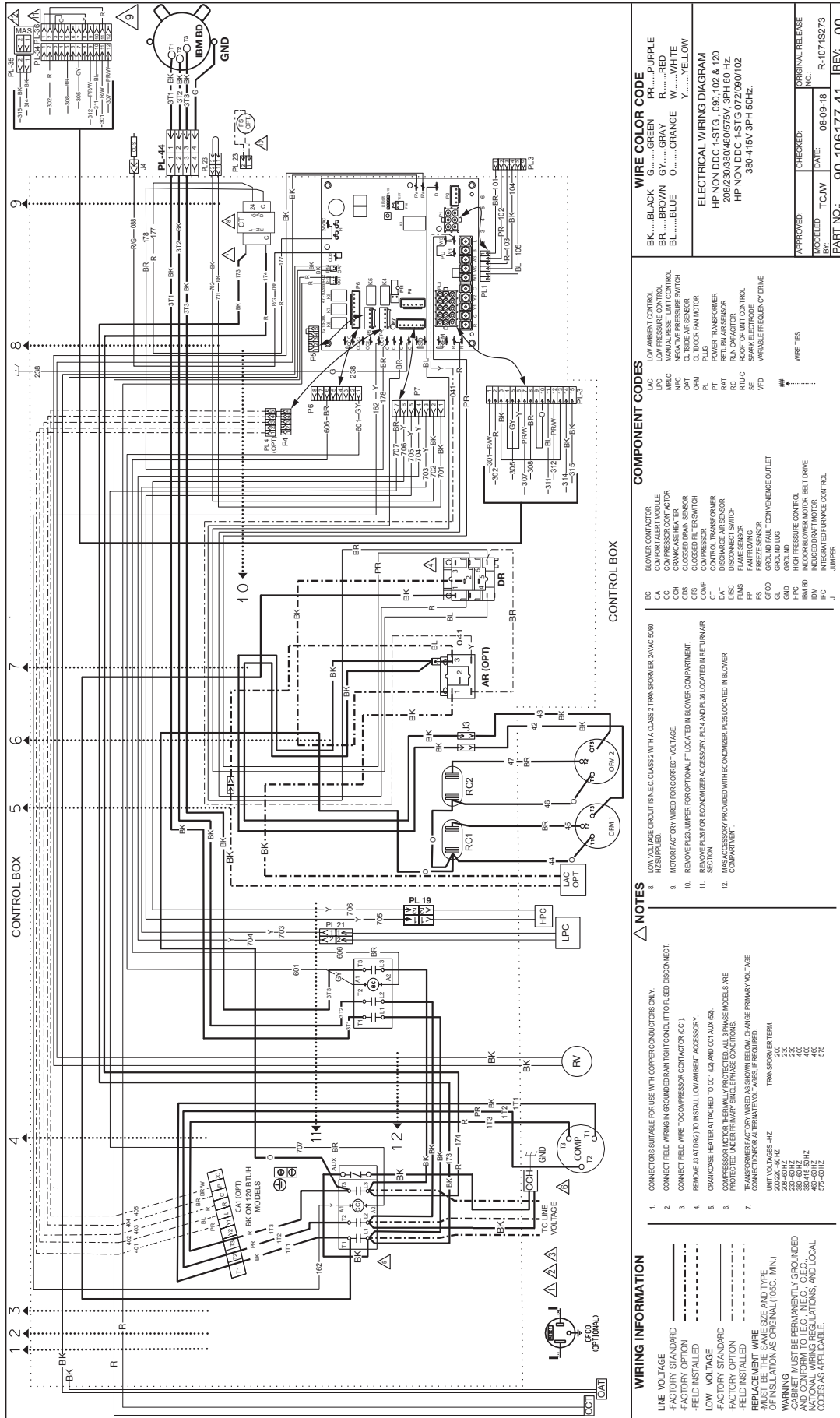
# TROUBLESHOOTING CHART

**▲ WARNING**

**DISCONNECT ALL POWER TO UNIT BEFORE SERVICING. CONTACTOR MAY BREAK ONLY ONE SIDE. FAILURE TO SHUT OFF POWER CAN CAUSE ELECTRICAL SHOCK RESULTING IN PERSONAL INJURY OR DEATH.**

SYMPTOM	POSSIBLE CAUSE	REMEDY
Unit will not run	<ul style="list-style-type: none"> <li>• Power off or loose electrical connection</li> <li>• Thermostat out of calibration-set too high</li> <li>• Defective contactor</li> <li>• Blown fuses</li> <li>• Transformer defective</li> <li>• High pressure control open (if provided)</li> <li>• Interconnecting low voltage wiring damaged</li> </ul>	<ul style="list-style-type: none"> <li>• Check for correct voltage at compressor contactor in control box</li> <li>• Reset</li> <li>• Check for 24 volts at contactor coil - replace if contacts are open</li> <li>• Replace fuses</li> <li>• Check wiring-replace transformer</li> <li>• Reset-also see high head pressure remedy-</li> <li>• Replace thermostat wiring</li> </ul>
Condenser fan runs, compressor doesn't	<ul style="list-style-type: none"> <li>• Run capacitor defective (single phase only)</li> <li>• Loose connection</li> <li>• Compressor stuck, grounded or open motor winding open internal overload.</li> <li>• Low voltage condition</li> </ul>	<ul style="list-style-type: none"> <li>• Replace</li> <li>• Check for correct voltage at compressor - check &amp; tighten all connections</li> <li>• Wait at least 2 hours for overload to reset. If still open, replace the compressor. At compressor terminals, voltage must be within 10% of rating plate volts when unit is operating.</li> </ul>
Insufficient cooling	<ul style="list-style-type: none"> <li>• Improperly sized unit</li> <li>• Improper airflow</li> <li>• Incorrect refrigerant charge</li> <li>• Air, non-condensibles or moisture in system</li> <li>• Incorrect voltage</li> </ul>	<ul style="list-style-type: none"> <li>• Recalculate load</li> <li>• Check - should be approximately 400 CFM per ton.</li> <li>• Charge per procedure attached to unit service panel.</li> <li>• Recover refrigerant, evacuate &amp; recharge, add filter drier</li> <li>• At compressor terminals, voltage must be within 10% of rating plate volts when unit is operating.</li> </ul>
Compressor short cycles	<ul style="list-style-type: none"> <li>• Incorrect voltage</li> <li>• Defective overload protector</li> <li>• Refrigerant undercharge</li> </ul>	<ul style="list-style-type: none"> <li>• At compressor terminals, voltage must be <math>\pm</math> 10% of nameplate marking when unit is operating.</li> <li>• Replace - check for correct voltage</li> <li>• Add refrigerant</li> </ul>
Registers sweat	<ul style="list-style-type: none"> <li>• Low evaporator airflow</li> </ul>	<ul style="list-style-type: none"> <li>• Increase speed of blower or reduce restriction - replace air filter</li> </ul>
High head-low vapor pressures	<ul style="list-style-type: none"> <li>• Restriction in liquid line, expansion device or filter drier</li> <li>• TXV does not open</li> </ul>	<ul style="list-style-type: none"> <li>• Remove or replace defective component</li> <li>• Replace TXV</li> </ul>
High head-high or normal vapor pressure - Cooling mode	<ul style="list-style-type: none"> <li>• Dirty condenser coil</li> <li>• Refrigerant overcharge</li> <li>• Condenser fan not running</li> <li>• Air or non-condensibles in system</li> </ul>	<ul style="list-style-type: none"> <li>• Clean coil</li> <li>• Correct system charge</li> <li>• Repair or replace</li> <li>• Recover refrigerant, evacuate &amp; recharge</li> </ul>
High head-high or normal vapor pressure - Heating mode	<ul style="list-style-type: none"> <li>• Low air flow - condenser coil</li> <li>• Refrigerant overcharge</li> <li>• Air or non-condensibles in system</li> <li>• Dirty condenser coil</li> </ul>	<ul style="list-style-type: none"> <li>• Check filters - correct to speed</li> <li>• Correct system charge</li> <li>• Recover refrigerant, evacuate &amp; recharge</li> <li>• Check filter - clean coil</li> </ul>
Low head-high vapor pressures	<ul style="list-style-type: none"> <li>• Defective Compressor valves</li> <li>• TXV won't close</li> </ul>	<ul style="list-style-type: none"> <li>• Replace compressor</li> <li>• Check TXV, replace</li> </ul>
Low vapor - cool compressor - iced evaporator coil	<ul style="list-style-type: none"> <li>• Low evaporator airflow</li> <li>• Operating below 65°F outdoors</li> <li>• Moisture in system</li> <li>• TXV limiting refrigerant flow</li> </ul>	<ul style="list-style-type: none"> <li>• Increase speed of blower or reduce restriction - replace air filter</li> <li>• Add Low Ambient Kit</li> <li>• Recover refrigerant - evacuate &amp; recharge - add filter drier</li> <li>• Replace TXV</li> </ul>
High vapor pressure	<ul style="list-style-type: none"> <li>• Excessive load</li> <li>• Defective compressor</li> </ul>	<ul style="list-style-type: none"> <li>• Recheck load calculation</li> <li>• Replace</li> </ul>
Fluctuating head & vapor pressures	<ul style="list-style-type: none"> <li>• TXV hunting</li> <li>• Air or non-condensibles in system</li> </ul>	<ul style="list-style-type: none"> <li>• Check TXV bulb clamp - check air distribution on coil - replace TXV</li> <li>• Recover refrigerant, evacuate &amp; recharge</li> </ul>
Gurgle or pulsing noise at expansion device or liquid line	<ul style="list-style-type: none"> <li>• Air or non-condensibles in system</li> </ul>	<ul style="list-style-type: none"> <li>• Recover refrigerant, evacuate &amp; recharge</li> </ul>

FIGURE 20



**WIRING INFORMATION**

- LINE VOLTAGE
- FACTORY STANDARD
- FIELD INSTALLED
- LOW VOLTAGE
- FACTORY OPTION
- FIELD INSTALLED
- REPLACEMENT WIRE
- MUST BE THE SAME SIZE AND TYPE OF INSULATION AS ORIGINAL (105C, MIN)

WARNING: WIRING MUST BE PERMANENTLY GROUNDED AND CONFORM TO I.E.C., N.E.C., C.E.C., NATIONAL WIRING REGULATIONS, AND LOCAL CODES AS APPLICABLE.

**NOTES**

1. CONNECTORS SUITABLE FOR USE WITH COPPER CONDUCTORS ONLY.
2. CONNECT FIELD WIRING IN GROUNDED RAIN TIGHT CONDUIT TO FUSED DISCONNECT.
3. CONNECT FIELD WIRE TO COMPRESSOR CONTACTOR (CC).
4. REMOVE DATA TAG TO INSTALL LOW AMBIENT ACCESSORY.
5. COMPRESSOR MOTOR THERMALLY PROTECTED ALL 3 PHASE MODELS ARE PROTECTED UNDER PRIMARY SINGLE PHASE CONDITION.
6. CONNECT ON FOR ALL THERMAL PROTECTORS IF REQUIRED.
7. UNIT VOLTAGES - HZ  
 TRANSFORMER TERN  
 208-220-230  
 230-240-250  
 380-400-420  
 460-480-500  
 575-600-630

**COMPONENT CODES**

- BC BLOWER CONTACTOR
- CC COMPRESSOR CONTACTOR
- CDH CRANKCASE HEATER
- CSB CLOSED BLIND SENSOR
- CSW CLOSURE SWITCH
- COMP COMPRESSOR
- CT CONTROL TRANSFORMER
- DISC DISCONNECT SWITCH
- FLMS FLAME SENSOR
- FP FAN PROOFING
- GFCD GROUND FAULT CONVENIENCE OUTLET
- GL GROUND LUG
- GND GROUND
- GRV GROUND RELEASE CONTROL
- IMED INDUCED BLOWER MOTOR BELT DRIVE
- IMD INDUCED DRAFT MOTOR
- INTC INTEGRATED FURNACE CONTROL JUMPER

**WIRE COLOR CODE**

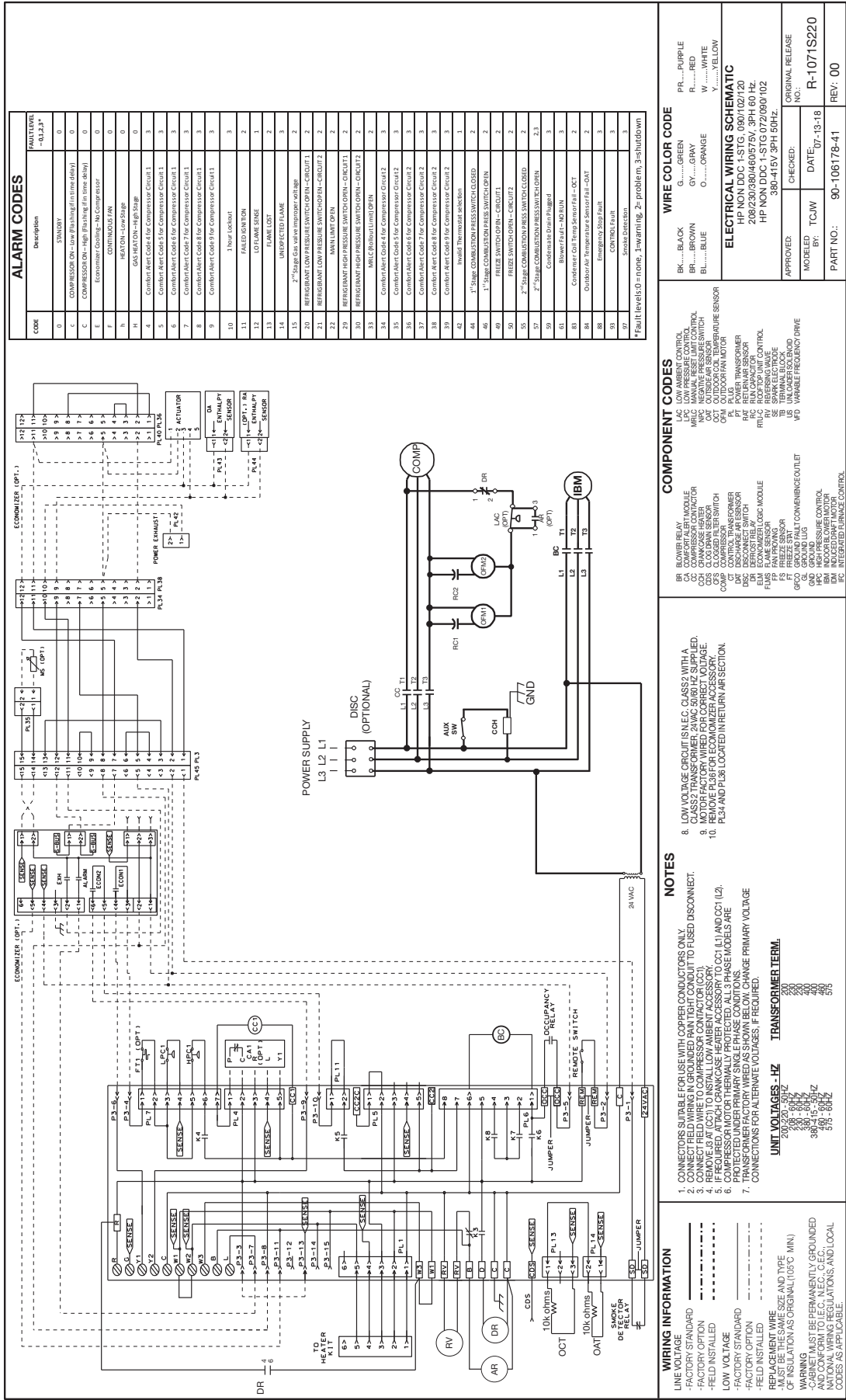
- BK.....BLACK
- G.....GREEN
- PR.....PURPLE
- BR.....BROWN
- GY.....GRAY
- R.....RED
- BL.....BLUE
- O.....ORANGE
- W.....WHITE
- Y.....YELLOW

**ELECTRICAL WIRING DIAGRAM**

HP NON DDC 1-STG. 090.102 & 120  
 208/230/380/460/575V. 3PH 60 HZ.  
 HP NON DDC 4-STG 072/090/102  
 380-415V 3PH 50HZ.

APPROVED:	CHECKED:	ORIGINAL RELEASE
BY:	DATE:	NO.:
TCJW	08-09-18	R-10715273
PART NO.:	90-106177-41	REV: 00

FIGURE 21



**WIRE COLOR CODE**

BK	BLACK
BR	BROWN
BL	BLUE
GR	GREEN
GY	GRAY
OR	ORANGE
PR	PURPLE
RD	RED
WH	WHITE
YL	YELLOW

**ELECTRICAL WIRING SCHEMATIC**

HP NON-DDC 1-5TG, 0807/0271/20  
4/2/22/24/24/24/24/24/24/24/24  
HP NON-DDC 1-5TG, 07/29/90/102

APPROVED: [Signature] DATE: 07-13-18  
MODELED BY: TCIW  
PART NO.: 90-106178-41 REV: 00

- COMPONENT CODES**
- BA BLOWER RELAY
  - CA COMBUSTION PRESSURE SWITCH
  - CC COMPRESSOR CONTACTOR
  - CS COOL DRAIN SENSOR
  - CO COOLING COIL
  - CO2 CO2 SENSOR
  - CCP COMPRESSOR
  - CT CONTROL TRANSFORMER
  - DC2 DISCONNECT SWITCH
  - ELM ECONOMIZER LOGIC MODULE
  - FS FLAME SENSOR
  - FLS FUEL SENSE
  - GT GROUND TERMINAL BLOCK
  - GND GROUND LUG
  - GFCI GROUND FAULT COUNTERMEASURE OUTLET
  - HC HIGH PRESSURE CONTROL
  - HM HUMIDITY SENSOR
  - IM INTEGRATED FURNACE CONTROL
  - LA LOW AMBIENT CONTROL
  - LAC LOW AMBIENT CONTROL
  - LS LIMIT SWITCH
  - MA MAIN AIRWAY MOTOR
  - PA PLUG
  - RAT RELAY
  - RFC ROOT TOP UNIT CONTROL
  - RTV RELAY
  - TB TERMINAL BLOCK
  - US UNIVERSAL MOTOR
  - VF VARIABLE FREQUENCY DRIVE

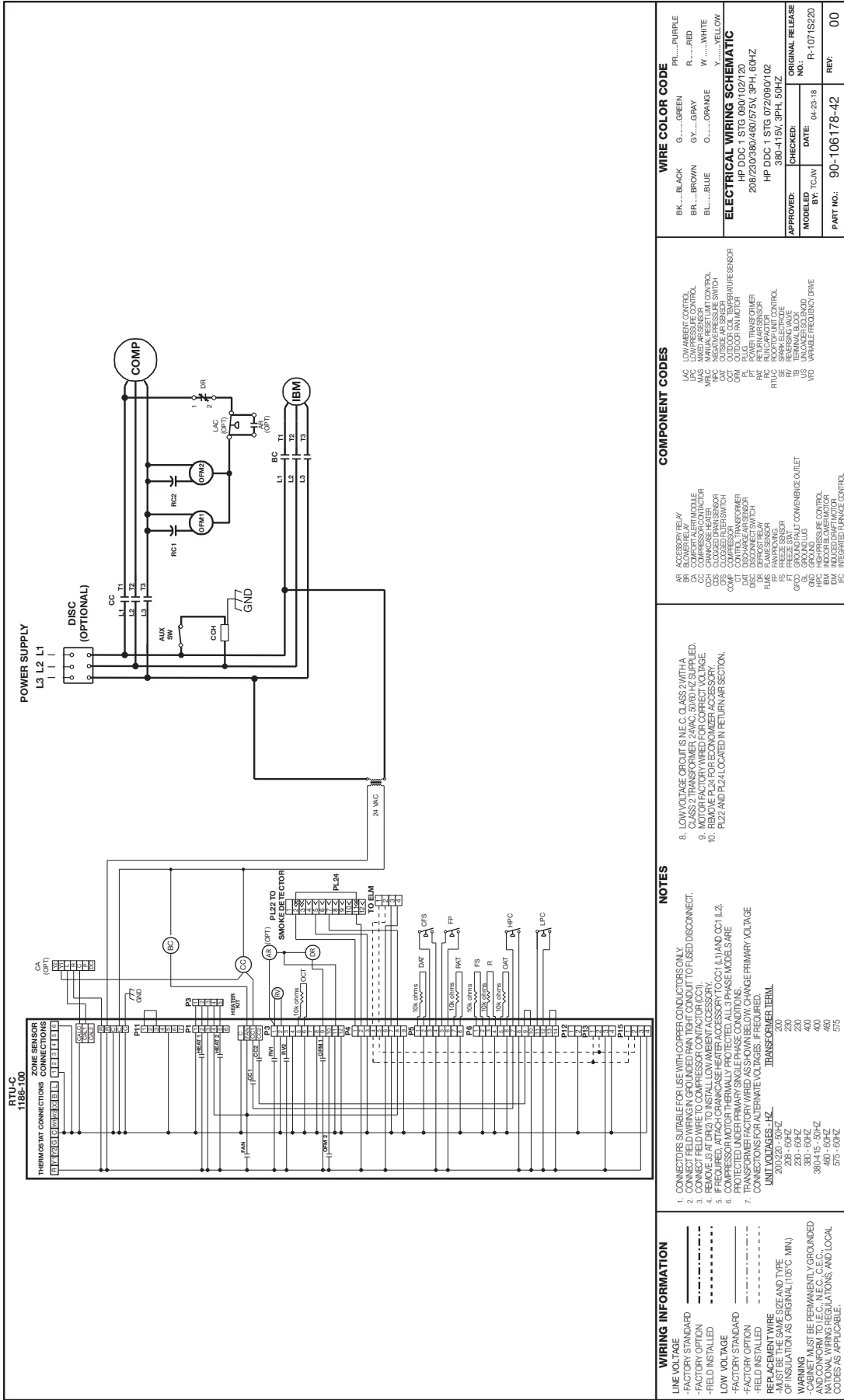
- NOTES**
1. CONNECTORS SUITABLE FOR USE WITH COPPER CONDUCTORS ONLY.
  2. CONNECT FIELD WIRE TO COMPRESSOR CONTACTOR (CC).
  3. REMOVE Jumper (CC) TO INSTALL LOW AMBIENT ACCESSORY.
  4. REMOVE Jumper (CC) TO INSTALL HEATER ACCESSORY TO CC1 (L1) AND CC2 (L2).
  5. IF REQUIRED, ATTACH CHANGEMAKE HEATER ACCESSORY TO CC1 (L1) AND CC2 (L2).
  6. PROTECTED UNDER PRIMARY SINGLE PHASE CONDITIONS. USE MODELS ARE CONNECTIONS FOR ALTERNATE VOLTAGES, IF REQUIRED.
  7. TRANSFORMER FACTORY WIRE AS SHOWN BELOW. CHANGE PRIMARY VOLTAGE CONNECTIONS FOR ALTERNATE VOLTAGES, IF REQUIRED.
- UNIT VOLTAGES - HZ**
- |               |                   |
|---------------|-------------------|
| 208/220-50/4Z | TRANSFORMER TERM. |
| 230-50/4Z     | 200               |
| 230-50/4Z     | 200               |
| 230-50/4Z     | 200               |
| 230-50/4Z     | 200               |
| 380-50/4Z     | 400               |
| 380-50/4Z     | 400               |
| 480-60/4Z     | 480               |
| 575-60/4Z     | 575               |

**WIRING INFORMATION**

- LINE VOLTAGE
- FACTORY WIRE
- FACTORY OPTION
- FIELD INSTALLED
- LOW VOLTAGE
- FACTORY STANDARD
- FACTORY OPTION
- FIELD INSTALLED
- REPLACE WIRE
- MUST BE THE SAME SIZE AND TYPE
- OF INSULATION AS ORIGINAL (USE C-MIN)
- WIRING MUST BE PERMANENTLY GROUNDING AND CONFORM TO I.E.C., N.E.C., C.E.C., AND NATIONAL WIRING REGULATIONS, AND LOCAL CODES AS APPLICABLE.



FIGURE 23



**WIRE COLOR CODE**

BK...BLACK	G...GREEN	PR...PURPLE
BR...BROWN	GY...GRAY	R...RED
BL...BLUE	OR...ORANGE	W...WHITE
		Y...YELLOW

**ELECTRICAL WIRING SCHEMATIC**

HP DDC 1 STG 900/102/120  
 208/230/380/480/575V, 3PH, 60HZ  
 HP DDC 1 STG 072/090/102  
 380-415V, 3PH, 50HZ

**APPROVED:** \_\_\_\_\_  
**MODELED BY:** TCAW  
**CHECKED:** \_\_\_\_\_  
**DATE:** 04-23-18

**ORIGINAL RELEASE NO.:** R-1071S220

**PART NO.:** 90-106178-42  
**REV:** 00

**COMPONENT CODES**

AR	ACCESSORY RELAY	LAC	LOW AMBIENT CONTROL
BR	BLOWER FAN	MAS	MAS WIND ANEMOMETER
CC	COMPRESSOR CONTACTOR	MCS	MCS NEGATIVE PRESSURE SWITCH
CC1	CLASS 2 TRANSFORMER 24VAC, 50/60 HZ SUPPLIED	OC	OUTDOOR AIR SENSOR
CC2	CLASS 2 TRANSFORMER 24VAC, 50/60 HZ SUPPLIED	OAT	OUTDOOR AIR TEMPERATURE SENSOR
CC3	CLASS 2 TRANSFORMER 24VAC, 50/60 HZ SUPPLIED	OFM	OUTDOOR FAN MOTOR
CC4	CLASS 2 TRANSFORMER 24VAC, 50/60 HZ SUPPLIED	PT	POWER TRANSFORMER
CC5	CLASS 2 TRANSFORMER 24VAC, 50/60 HZ SUPPLIED	RAT	RETURN AIR SENSOR
CC6	CLASS 2 TRANSFORMER 24VAC, 50/60 HZ SUPPLIED	RFL	RETURN AIR FAN MOTOR
CC7	CLASS 2 TRANSFORMER 24VAC, 50/60 HZ SUPPLIED	RFLC	RETURN AIR FAN MOTOR CONTROL
CC8	CLASS 2 TRANSFORMER 24VAC, 50/60 HZ SUPPLIED	RW	REFRESHING VALVE
CC9	CLASS 2 TRANSFORMER 24VAC, 50/60 HZ SUPPLIED	TR	THERMAL RELAY
CC10	CLASS 2 TRANSFORMER 24VAC, 50/60 HZ SUPPLIED	UB	UNIVERSAL BOARD
CC11	CLASS 2 TRANSFORMER 24VAC, 50/60 HZ SUPPLIED	VFD	VARIABLE FREQUENCY DRIVE

- NOTES**
- CONNECTORS SUITABLE FOR USE WITH COPPER CONDUCTORS ONLY.
  - CONNECT FIELD WIRE TO GROUND OR RAN TIGHT CONDUIT TO FIELD DISCONNECT.
  - REMOVE J1 AT DR2 TO INSTALL LOW AMBIENT ACCESSORY (CC1).
  - REMOVE J1 AT DR2 TO INSTALL LOW AMBIENT ACCESSORY (CC1, L1 AND CC1 (L1).
  - COMPRESSOR MOTOR THERMALLY PROTECTED. ALL 3 PHASE MODELS ARE PROTECTED UNDER PRIMARY SINGLE PHASE CONDITIONS.
  - TRANSFORMER FACTORY WIRE AS SHOWN BELOW. CHANGE PRIMARY VOLTAGE CONNECTIONS FOR ALTERNATE VOLTAGES. (IF REQUIRED).
  - TRANSFORMER TERMINAL VOLTAGE:
 

208-230-380HZ	230
230-60HZ	230
230-60HZ	230
380-415HZ	480
480-60HZ	480
575-60HZ	575

**WIRING INFORMATION**

LINE VOLTAGE \_\_\_\_\_

-FACTORY STANDARD \_\_\_\_\_

-FACTORY OPTION \_\_\_\_\_

-FIELD INSTALLED \_\_\_\_\_

LOW VOLTAGE \_\_\_\_\_

-FACTORY STANDARD \_\_\_\_\_

-FACTORY OPTION \_\_\_\_\_

-FIELD INSTALLED \_\_\_\_\_

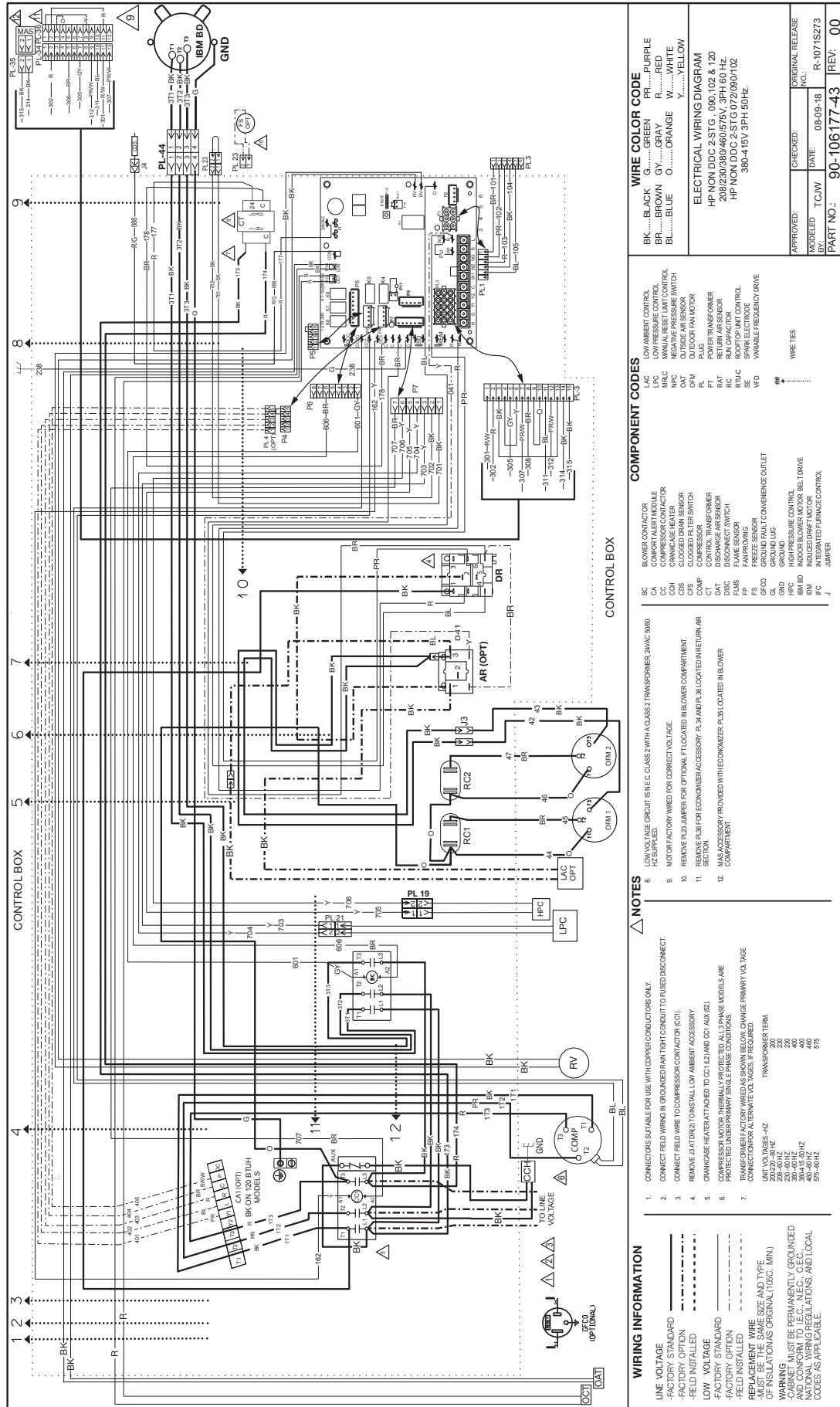
REPLACEMENT WIRE SIZE AND TYPE \_\_\_\_\_

OF INSULATION AS ORIGINAL (105°C MIN)

**WARNING**  
 -CABINET MUST BE PERMANENTLY GROUNDED  
 -WIRING MUST BE IN ACCORDANCE WITH LOCAL NATIONAL WIRING REGULATIONS, AND LOCAL CODES AS APPLICABLE.



FIGURE 24



**WIRING INFORMATION**

- LINE VOLTAGE
- FACTORY STANDARD
- FACTORY OPTION
- FIELD INSTALLED
- LOW VOLTAGE
- FACTORY STANDARD
- FACTORY OPTION
- FIELD INSTALLED
- REPLACEMENT WIRE
- MUST BE THE SAME SIZE AND TYPE
- MUST BE OF INSULATION AS ORIGINAL (105C. MIN.)
- WARNING
- MUST BE PERMANENTLY GROUNDED
- AND CONFORM TO I.E.C., N.E.C., C.E.C.
- NATIONAL WIRING REGULATIONS, AND LOCAL
- CODES AS APPLICABLE.

**NOTES**

1. CONNECTORS SUITABLE FOR USE WITH COPPER CONDUCTORS ONLY.
2. CONNECT FIELD WIRING IN GROUND/RAIN TIGHT CONDUIT TO FUSED DISCONNECT.
3. CONNECT FIELD WIRE TO COMPRESSOR CONTACTOR (CC).
4. CONNECT GROUND TO INSTALL LOW AMBIENT ACCESSORY.
5. CRANKCASE HEATER ATTACHED TO C11 AND OCT AUX (S).
6. COMPRESSOR MOTOR THERMALLY PROTECTED. ALL PHASE MODELS ARE PROTECTED UNDER PRIMARY SINGLE-PHASE CONDITIONS.
7. CONNECTIONS TO ALTERNATE VOLTAGES IF REQUIRED.
 

UNIT VOLTAGES -4HZ	TRANSFORMER TERM.
200-220-240HZ	200
220-240HZ	220
380-440-480HZ	400
480-500HZ	480
575-600HZ	575
8. LOW VOLTAGE CIRCUIT IS N.E.C. CLASS 2 WITH A CLASS 2 TRANSFORMER. 2WVAC 50/60 HZ SUPPLIED.
9. MOTOR FACTORY WIRED FOR CORRECT VOLTAGE.
10. REMOVE P423 JUMPER FOR OPTIONAL FT LOCATED IN BLOWER COMPARTMENT.
11. REMOVE P438 FOR ECONOMIZER ACCESSORY. FL 34 AND P438 LOCATED IN RETURN AIR SECTION.
12. GAS ACCESSORY PROVIDED WITH ECONOMIZER. P438 LOCATED IN BLOWER COMPARTMENT.

**COMPONENT CODES**

- B2 BLOWER CONTACTOR
- CC COMPRESSOR CONTACTOR
- CH CRANKCASE HEATER
- CS CLOSURE SAFETY SENSOR
- CSS CLOSED SAFETY SWITCH
- COMP COMPRESSOR
- CONTROL CONTROL TRANSFORMER
- DR DISCONNECT SWITCH
- FLS FLAME SENSOR
- FAN FAN MOTOR
- FP FAN PROTECT
- GFCO GROUND FAULT CONVENIENCE OUTLET
- GL GROUND LUG
- GND GROUND
- IND INDUCED DRAFT MOTOR
- BM BLOWER MOTOR BELT DRIVE
- DM INDUCED DRAFT MOTOR
- INT INTEGRATED FURNACE CONTROL
- J JUMPER

**WIRE COLOR CODE**

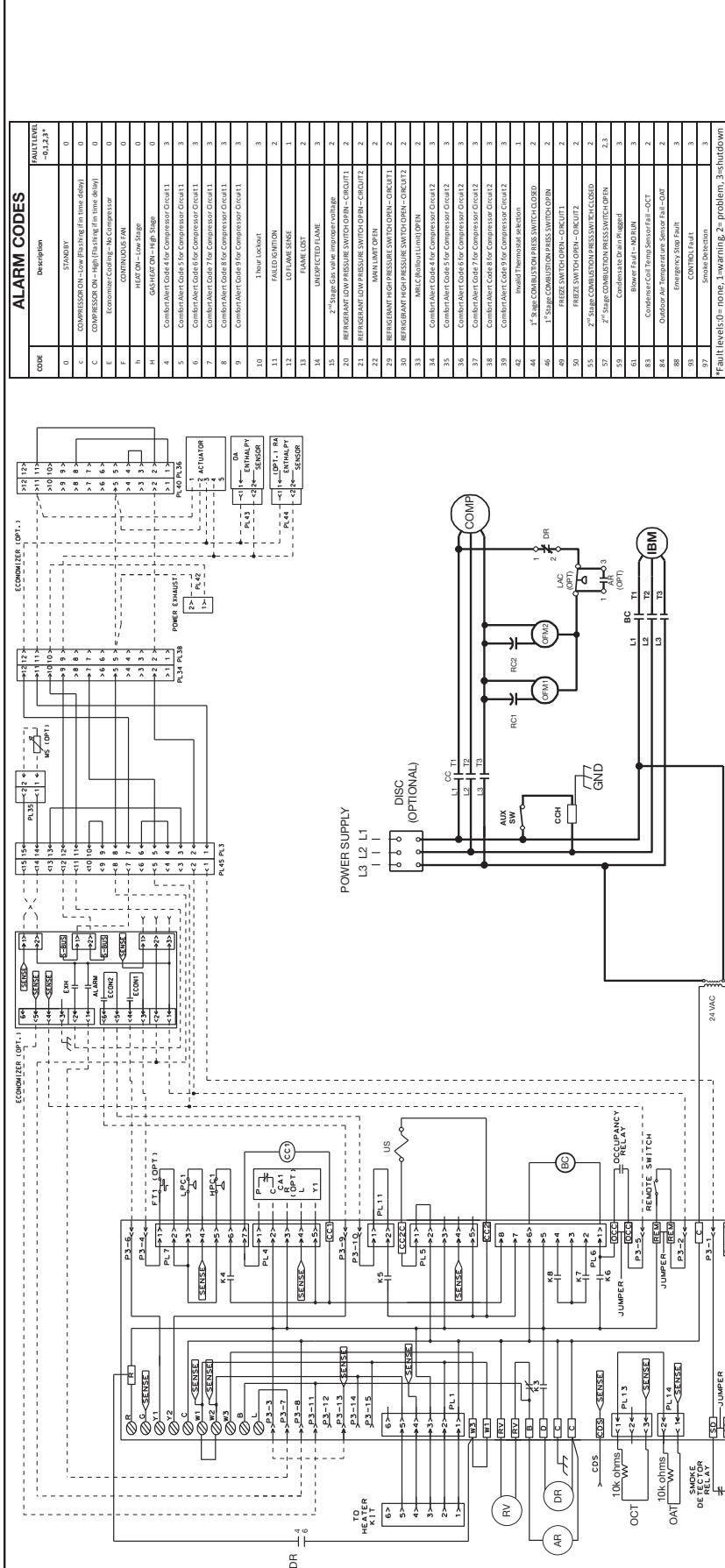
- BK.....BLACK
- G.....GREEN
- PR.....PURPLE
- BR.....BROWN
- GY.....GRAY
- R.....RED
- BL.....BLUE
- O.....ORANGE
- W.....WHITE
- Y.....YELLOW

**ELECTRICAL WIRING DIAGRAM**

HP NON DDC 2-STG. 090,102 & 120  
 208/230/380/460/575V, 3PH 60 HZ.  
 HP NON DDC 2-STG 072/090/102  
 380-415V 3PH 50HZ.

APPROVED:	CHECKED:	ORIGINAL RELEASE
TCJW	NO.:	R-1071S273
DATE: 08-09-18	BY:	
MODELED:		
PART NO.:	90-106177-43	REV: 00

FIGURE 25



ALARM CODES	
CODE	Description
0	STANDBY
1	COMPRESSOR ON - HIGH (Pressure Rise from Standby)
2	COMPRESSOR ON - High (Pressure Rise from Standby)
3	Compressor Cooling Re-Compressor
4	Control Board 1 - High Stage
5	Control Board 2 - High Stage
6	Control Board 3 - High Stage
7	Control Board 4 - High Stage
8	Control Board 5 - High Stage
9	Control Board 6 - High Stage
10	Control Board 7 - High Stage
11	Control Board 8 - High Stage
12	Control Board 9 - High Stage
13	Control Board 10 - High Stage
14	Control Board 11 - High Stage
15	Control Board 12 - High Stage
16	Control Board 13 - High Stage
17	Control Board 14 - High Stage
18	Control Board 15 - High Stage
19	Control Board 16 - High Stage
20	Control Board 17 - High Stage
21	Control Board 18 - High Stage
22	Control Board 19 - High Stage
23	Control Board 20 - High Stage
24	Control Board 21 - High Stage
25	Control Board 22 - High Stage
26	Control Board 23 - High Stage
27	Control Board 24 - High Stage
28	Control Board 25 - High Stage
29	Control Board 26 - High Stage
30	Control Board 27 - High Stage
31	Control Board 28 - High Stage
32	Control Board 29 - High Stage
33	Control Board 30 - High Stage
34	Control Board 31 - High Stage
35	Control Board 32 - High Stage
36	Control Board 33 - High Stage
37	Control Board 34 - High Stage
38	Control Board 35 - High Stage
39	Control Board 36 - High Stage
40	Control Board 37 - High Stage
41	Control Board 38 - High Stage
42	Control Board 39 - High Stage
43	Control Board 40 - High Stage
44	Control Board 41 - High Stage
45	Control Board 42 - High Stage
46	Control Board 43 - High Stage
47	Control Board 44 - High Stage
48	Control Board 45 - High Stage
49	Control Board 46 - High Stage
50	Control Board 47 - High Stage
51	Control Board 48 - High Stage
52	Control Board 49 - High Stage
53	Control Board 50 - High Stage
54	Control Board 51 - High Stage
55	Control Board 52 - High Stage
56	Control Board 53 - High Stage
57	Control Board 54 - High Stage
58	Control Board 55 - High Stage
59	Control Board 56 - High Stage
60	Control Board 57 - High Stage
61	Control Board 58 - High Stage
62	Control Board 59 - High Stage
63	Control Board 60 - High Stage
64	Control Board 61 - High Stage
65	Control Board 62 - High Stage
66	Control Board 63 - High Stage
67	Control Board 64 - High Stage
68	Control Board 65 - High Stage
69	Control Board 66 - High Stage
70	Control Board 67 - High Stage
71	Control Board 68 - High Stage
72	Control Board 69 - High Stage
73	Control Board 70 - High Stage
74	Control Board 71 - High Stage
75	Control Board 72 - High Stage
76	Control Board 73 - High Stage
77	Control Board 74 - High Stage
78	Control Board 75 - High Stage
79	Control Board 76 - High Stage
80	Control Board 77 - High Stage
81	Control Board 78 - High Stage
82	Control Board 79 - High Stage
83	Control Board 80 - High Stage
84	Control Board 81 - High Stage
85	Control Board 82 - High Stage
86	Control Board 83 - High Stage
87	Control Board 84 - High Stage
88	Control Board 85 - High Stage
89	Control Board 86 - High Stage
90	Control Board 87 - High Stage
91	Control Board 88 - High Stage
92	Control Board 89 - High Stage
93	Control Board 90 - High Stage
94	Control Board 91 - High Stage
95	Control Board 92 - High Stage
96	Control Board 93 - High Stage
97	Control Board 94 - High Stage

\*Fault levels: 0 = none, 1 = warning, 2 = problem, 3 = shutdown

WIRE COLOR CODE			
BL	BLACK	PR	PURPLE
BR	BROWN	RD	RED
BU	BLUE	W	WHITE
GY	GRAY	YL	YELLOW
OR	ORANGE		

ELECTRICAL WIRING SCHEMATIC			
HP	NON-DDC	2-STG	0801/02/120
HP	NON-DDC	460/575V	3PH 60 Hz
HP	NON-DDC	2-STG	0720/090/102
HP	NON-DDC	3PH	50Hz

APPROVED:			
CHECKED:	NO.	DATE:	
MODEL:	TCJW	DATE:	07-13-18
PART NO.:	90-106178-43	REV:	00

COMPONENT CODES	
BL	BLOWER RELAY
CA	CONTROL ALERT MODULE
CR	CRANKCASE HEATER
CS	CONDENSATE SWITCH
CT	COMPRESSOR THERMAL PROTECTION
DF	DISCHARGE AIR SENSOR
DR	DRY CONTACT SWITCH
EUM	ECONOMIZER LOGIC MODULE
FF	FAN FAN FLOW SWITCH
FR	FREEZE STAT
GC	GROUND FAULT COMMENCEMENT OUTLET
GR	GROUND RELAY
IC	INDUCED DRAFT MOTOR
IM	INDUCED DRAFT MOTOR
IN	INTEGRATED VOLTAGE CONTROL

8. LOW VOLTAGE CIRCUIT IS N.E.C. CLASS 2 WITH A GROUNDING REQUIREMENT FOR CORRECT VOLTAGE.  
 9. MOTOR FACTORY WIRE FOR CORRECT VOLTAGE.  
 10. REMOVE PL.38 FOR ECONOMIZER ACCESSORY.  
 PL.34 AND PL.38 LOCATED IN RETURN AIR SECTION.

**NOTES**

- CONNECTORS SUITABLE FOR USE WITH COPPER CONDUCTORS ONLY.
- CONNECT FIELD WIRING IN GROUNDED RAIN TIGHT CONDUIT TO FUSED DISCONNECT.
- REMOVE LEAF (CC) TO INSTALL LOW AMBIENT ACCESSORY.
- COMPRESSOR MOTOR THERMALLY PROTECTED. ALL 3 PHASE MODELS ARE PROTECTED UNDER PRIMARY SINGLE PHASE CONDITIONS.
- TRANSFORMER FACTORY WIRE AS SHOWN BELOW. CHANGE PRIMARY VOLTAGE CONNECTIONS FOR ALTERNATE VOLTAGES, IF REQUIRED.

UNIT VOLTAGES - HZ	TRANSFORMER TAP
200-220-50/60	200
230-240-50/60	230
240-250-50/60	250
380-415-50/60	400
460-480-50/60	460
575-600-50/60	575

**WIRING INFORMATION**

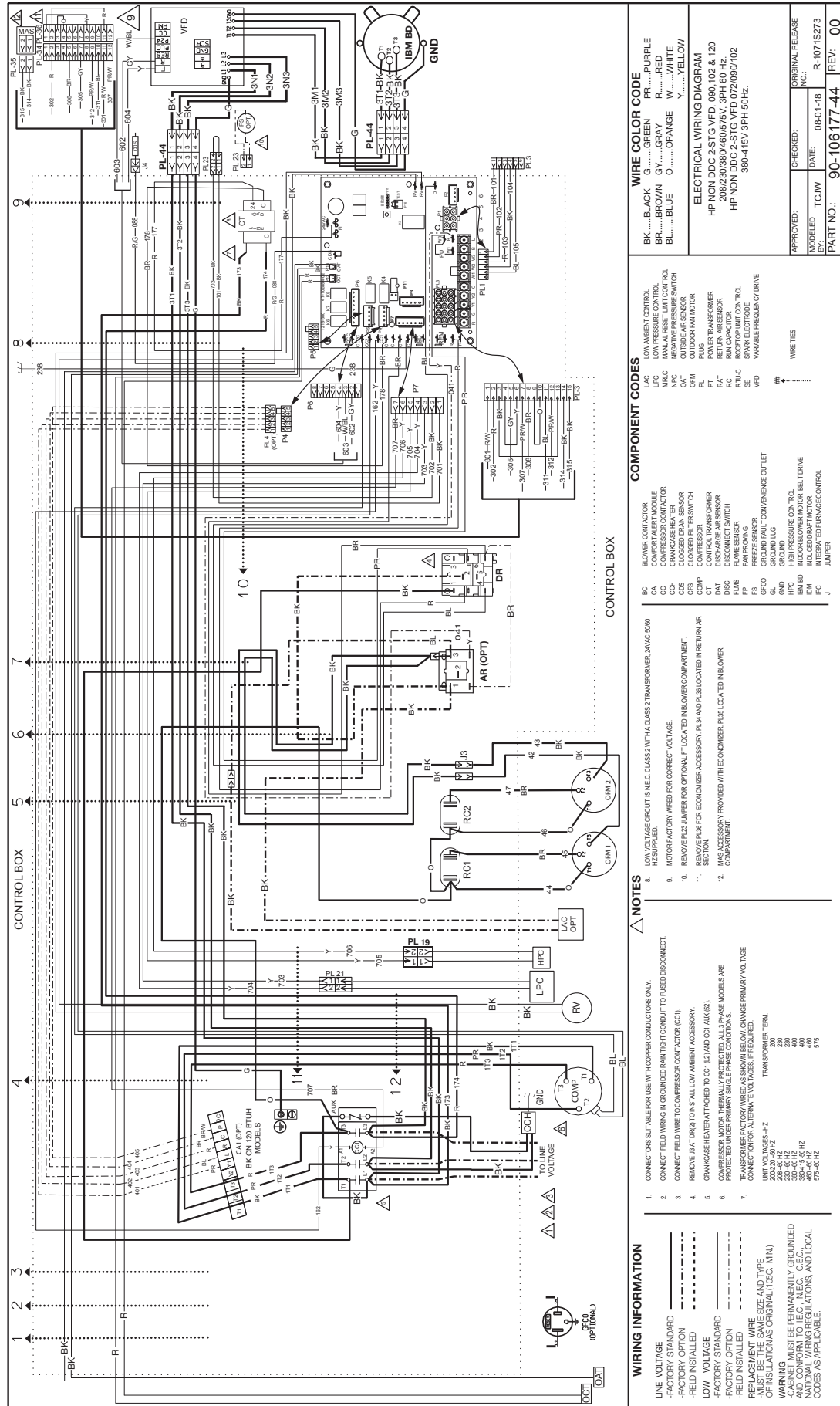
LINE VOLTAGE  
 -FACTORY STANDARD  
 -FACTORY OPTION  
 -FIELD INSTALLED

LOW VOLTAGE  
 -FACTORY STANDARD  
 -FACTORY OPTION  
 -FIELD INSTALLED

REPLACEMENT WIRE SIZE AND TYPE  
 OF INSULATION AS ORIGINAL (105°C MIN)

WARNING  
 -CABINET MUST BE PERMANENTLY GROUNDED  
 AND CONFORM TO I.E.C., N.E.C., C.E.C.  
 AND LOCAL ELECTRICAL REGULATIONS, AND LOCAL CODES AS APPLICABLE.

FIGURE 26



**WIRING INFORMATION**

- 1. CONNECTORS SUITABLE FOR USE WITH COPPER CONDUCTORS ONLY.
- 2. CONNECT FIELD WIRING IN GROUND/RAIN TIGHT CONDUIT TO FUSED DISCONNECT.
- 3. CONNECT FIELD WIRE TO COMPRESSOR CONTACTOR (C2).
- 4. REMOVE JUMPER TO INSTALL LOW AMBIENT ACCESSORY.
- 5. CRANKCASE HEATER THERMALLY PROTECTED. ALL 3-PHASE MODELS ARE PROTECTED UNDER PRIMARY SINGLE-PHASE CONDITIONS.
- 6. COMPRESSOR MOTOR THERMALLY PROTECTED. ALL 3-PHASE MODELS ARE PROTECTED UNDER PRIMARY SINGLE-PHASE CONDITIONS.
- 7. CONNECTIONS TO ALTERNATE VOLTAGES IF REQUIRED.

**NOTES**

- 8. LOW VOLTAGE CIRCUIT IS N.E.C. CLASS 2 WITH A CLASS 2 TRANSFORMER. 24VAC 50/60 HZ. SUPPLIED.
- 9. MOTOR FACTORY WIRED FOR CORRECT VOLTAGE.
- 10. REMOVE P423 JUMPER FOR OPTIONAL FT LOCATED IN BLOWER COMPARTMENT SECTION.
- 11. REMOVE P428 FOR ECONOMIZER ACCESSORY. P434 AND P438 LOCATED IN RETURN AIR COMPARTMENT.
- 12. GAS ACCESSORY PROVIDED WITH ECONOMIZER. P435 LOCATED IN BLOWER COMPARTMENT.

**COMPONENT CODES**

B2	BLOWER CONTACTOR
CC	COMPRESSOR CONTACTOR
CH	CRANKCASE HEATER
CS	CLOSED SWITCH
CS	CLOSED SWITCH
COMP	COMPRESSOR
CT	CONTROL TRANSFORMER
DISC	DISCONNECT SWITCH
FANS	FAN FLOW SWITCH
FP	FAN PROTECT
FT	FURNACE THERMISTOR
GFCO	GROUND FAULT CIRCUIT INTERRUPTER
GL	GROUND LUG
GND	GROUND
IND	INDUCED DRAFT MOTOR
INDM	INDUCED DRAFT MOTOR BELT DRIVE
INT	INTEGRATED FURNACE CONTROL
J	JUMPER

**WIRE COLOR CODE**

BK	BLACK	G	GREEN	PR	PURPLE
BR	BROWN	GY	GRAY	R	RED
BL	BLUE	O	ORANGE	W	WHITE
		Y	YELLOW		

**ELECTRICAL WIRING DIAGRAM**

HP NON DDC 2-STG VFD, 090, 102 & 120
208/230/380/460/575V, 3PH 60 HZ.
HP NON DDC 2-STG VFD 072/090/102
380-415V 3PH 50HZ.

**APPROVED:**

CHECKED:	DATE:	08-01-18
NO.:	BY:	TCJW
ORIGINAL RELEASE:	PART NO.:	90-106177-44
R-10715273	REV:	00

FIGURE 27

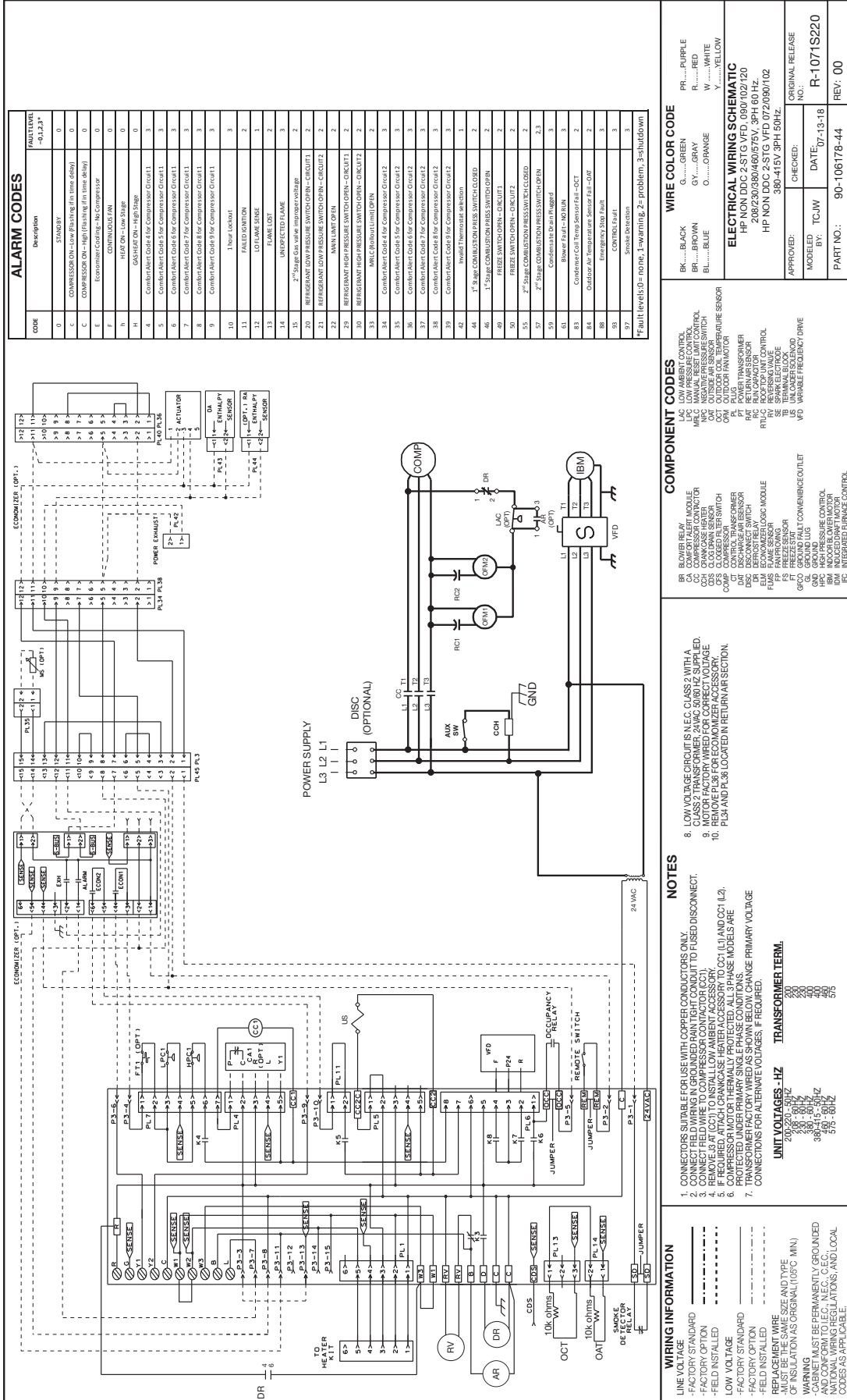
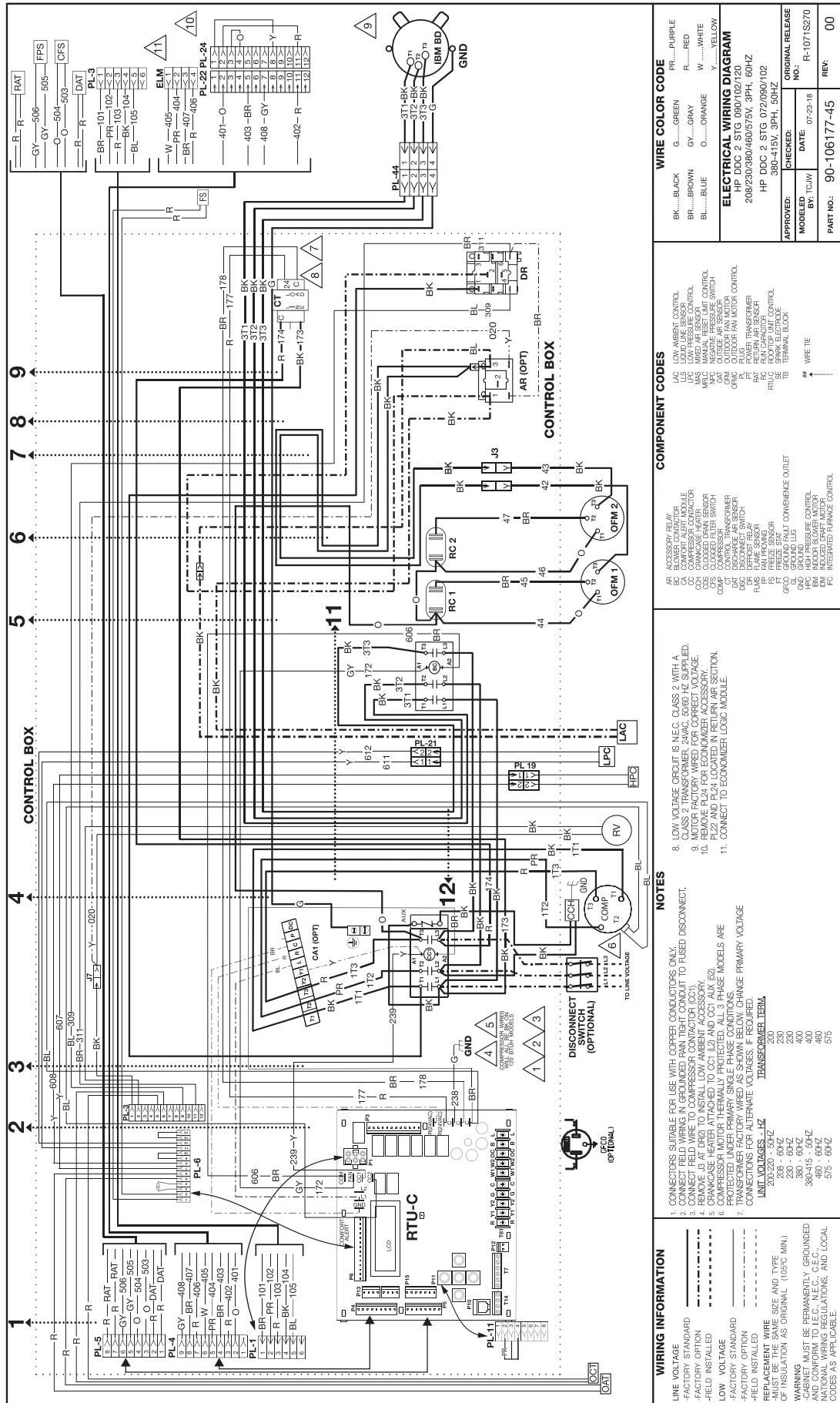


FIGURE 28



**WIRING INFORMATION**

LINE VOLTAGE  
 -FACTORY STANDARD  
 -FACTORY OPTION  
 -FIELD INSTALLED

LOW VOLTAGE  
 -FACTORY STANDARD  
 -FACTORY OPTION  
 -FIELD INSTALLED

REPLACEMENT WIRE SIZE AND TYPE  
 OF INSULATION AS ORIGINAL (105°C MIN.)

WARNING  
 -CABINET MUST BE PERMANENTLY GROUNDED  
 -WIRING MUST BE IN ACCORDANCE WITH ALL  
 NATIONAL WIRING REGULATIONS, AND LOCAL  
 CODES AS APPLICABLE.

**NOTES**

- CONNECTORS SUITABLE FOR USE WITH COPPER CONDUCTORS ONLY.
- CONNECT FIELD WIRING IN GROUNDED RAIN TIGHT CONDUIT TO FUSED DISCONNECT.
- REPLACE FUSED DISCONNECT WITH 15 AMPERE 250 VOLT CLASS 2 DISCONNECT.
- CRANKCASE HEATER ATTACHED TO CCI (L2) AND CCI AUX (E2).
- COMPRESSOR MOTOR THERMALLY PROTECTED. ALL 3 PHASE MODELS ARE PROTECTED UNDER PRIMARY SINGLE PHASE CONDITIONS.
- CONNECTIONS FOR ALTERNATE VOLTAGES, IF REQUIRED.

UNIT VOLTAGES - HZ

200-220	50-60
208-240	50-60
230	50-60
380-415	50-60
480-480	50-60
575-575	50-60

TRANSFORMER TAP

200  
230  
380  
480

8. LOW VOLTAGE CIRCUIT IS NEG. CLASS 2 WITH A CLASS 2 TRANSFORMER, 2WAC, 50/60 HZ SUPPLIED.

9. MOTOR FACTORY WIRED FOR CORRECT VOLTAGE.

10. RECONNECT TO ECONOMIZER ACCESSORY.

11. CONNECT TO ECONOMIZER LOGIC MODULE.

**COMPONENT CODES**

AR ACCESSORY RELAY  
 CA COMPACT ALERT MODULE  
 CCH CRANKCASE HEATER  
 CCI CRANKCASE HEATER  
 CDS CLOSED CIRCUIT SWITCH  
 COMP COMPRESSOR  
 DAT DATA TERMINAL BLOCK  
 DR DISCONNECT SWITCH  
 FLAS FLAME SENSOR  
 FS FREEZE SENSOR  
 GFD GROUND FAULT CONVENIENCE OUTLET  
 GL GROUND LUG  
 HPC HIGH PRESSURE CONTROL  
 HPS HIGH PRESSURE SWITCH  
 IM INDICATED MOTOR  
 FC INTEGRATED FLUANGE CONTROL

**WIRE COLOR CODE**

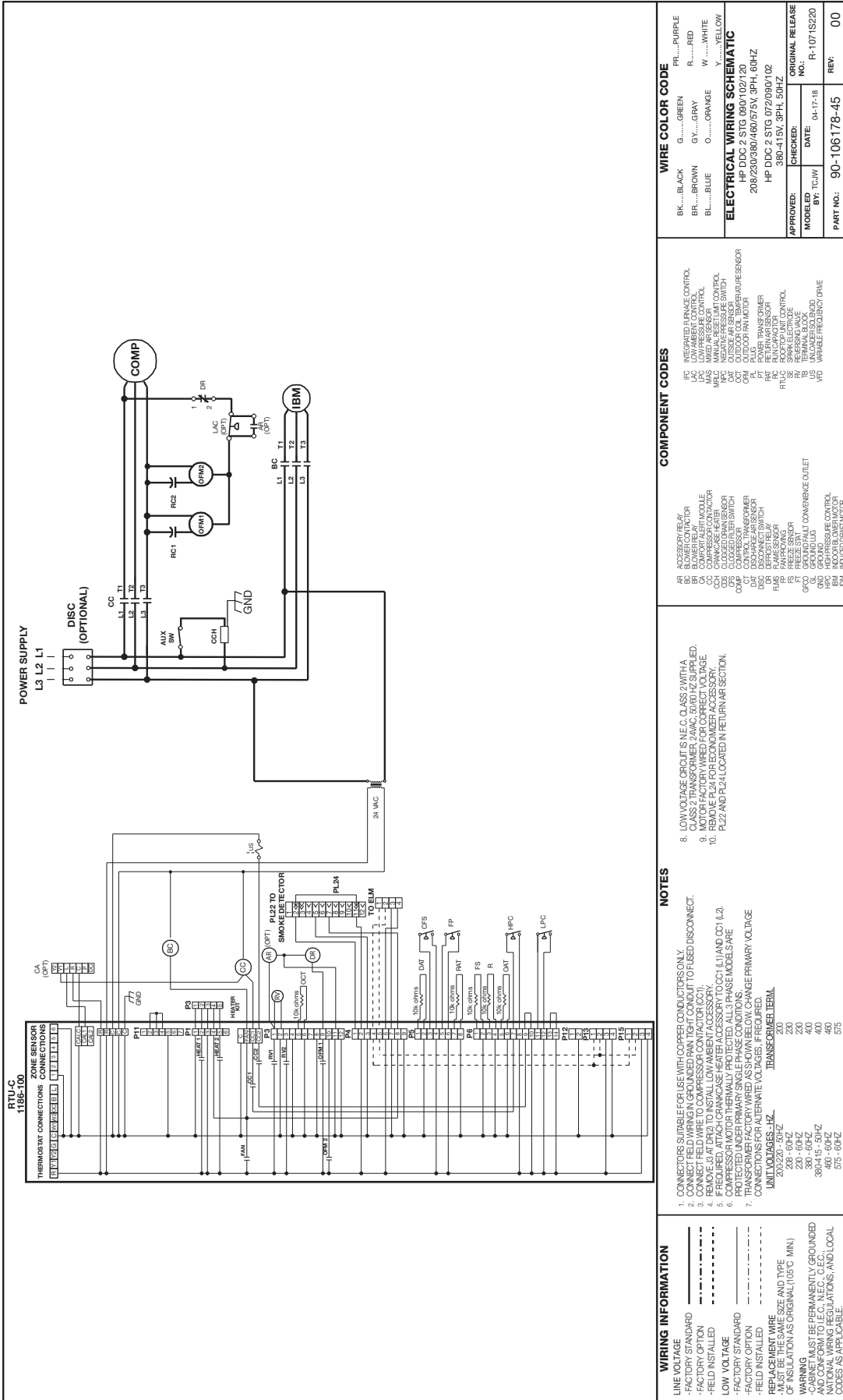
BK.....BLACK	GY.....GREEN	PR.....PURPLE
BR.....BROWN	GY.....GRAY	R.....RED
BL.....BLUE	O.....ORANGE	W.....WHITE
		Y.....YELLOW

**ELECTRICAL WIRING DIAGRAM**

HP DDC 2 STG 0601/02/130  
 208/230/380/480/575V, 3PH, 60HZ  
 HP DDC 2 STG 072/080/102  
 380-415V, 3PH, 50HZ

APPROVED: \_\_\_\_\_ CHECKED: \_\_\_\_\_ ORIGINAL RELEASE NO.: \_\_\_\_\_  
 MODELED BY: TCAV DATE: 07-23-18 R-10715270  
 PART NO.: 90-106177-45 REV: 00

FIGURE 29



WIRE COLOR CODE		
BK...BLACK	G.....GREEN	PR....PURPLE
BR...BROWN	OY.....GRAY	R.....RED
BL...BLUE	O.....ORANGE	W....WHITE
		Y....YELLOW

ELECTRICAL WIRING SCHEMATIC		
APPROVED:	CHECKED:	DATE:
208/230/380/480/575V, 3PH, 60HZ	HP DDC 2 STG, 0729/09/01/02	04-17-18
380-415V, 3PH, 50HZ		

COMPONENT CODES	
IFC	INTEGRATED FLUENCE CONTROL
LAC	LOW PRESSURE CONTROL
LPC	LOW PRESSURE CONTROL
MPC	MANUAL RESET LIMIT CONTROL
NPC	NEGATIVE PRESSURE SWITCH
OC	OVER CURRENT PROTECTION
OCT	OUTDOOR COIL TEMPERATURE SENSOR
PT	POWER TRANSFORMER
RC1	REVERSE CURRENT PROTECTION
RC2	REVERSE CURRENT PROTECTION
TR	TEMPERATURE SENSITIVE RESETTING DEVICE
US	UNDERVOLT SENSING DEVICE
VFD	VARIABLE FREQUENCY DRIVE

NOTES	
1.	CONNECTORS SUITABLE FOR USE WITH COPPER CONDUCTORS ONLY.
2.	CONNECT FIELD WIRE TO GROUNDING RAN TIGHT CONDUIT TO FIELD DISCONNECT.
3.	REMOVE LEAD FROM COMPRESSOR CONTACTOR (CC1).
4.	REMOVE LEAD FROM LOW AMBIENT ACCESSORY (CC11 AND CC11.1).
5.	COMPRESSOR MOTOR THERMALLY PROTECTED. ALL 3 PHASE MODELS ARE PROTECTED UNDER PRIMARY SINGLE PHASE CONDITIONS.
6.	CONNECTIONS FOR ALTERNATE VOLTAGES, IF REQUIRED, ARE SHOWN BELOW.
7.	TRANSFORMER FACTORY WIRE AS SHOWN BELOW, CHANGE PRIMARY VOLTAGE CONNECTIONS FOR ALTERNATE VOLTAGES, IF REQUIRED.

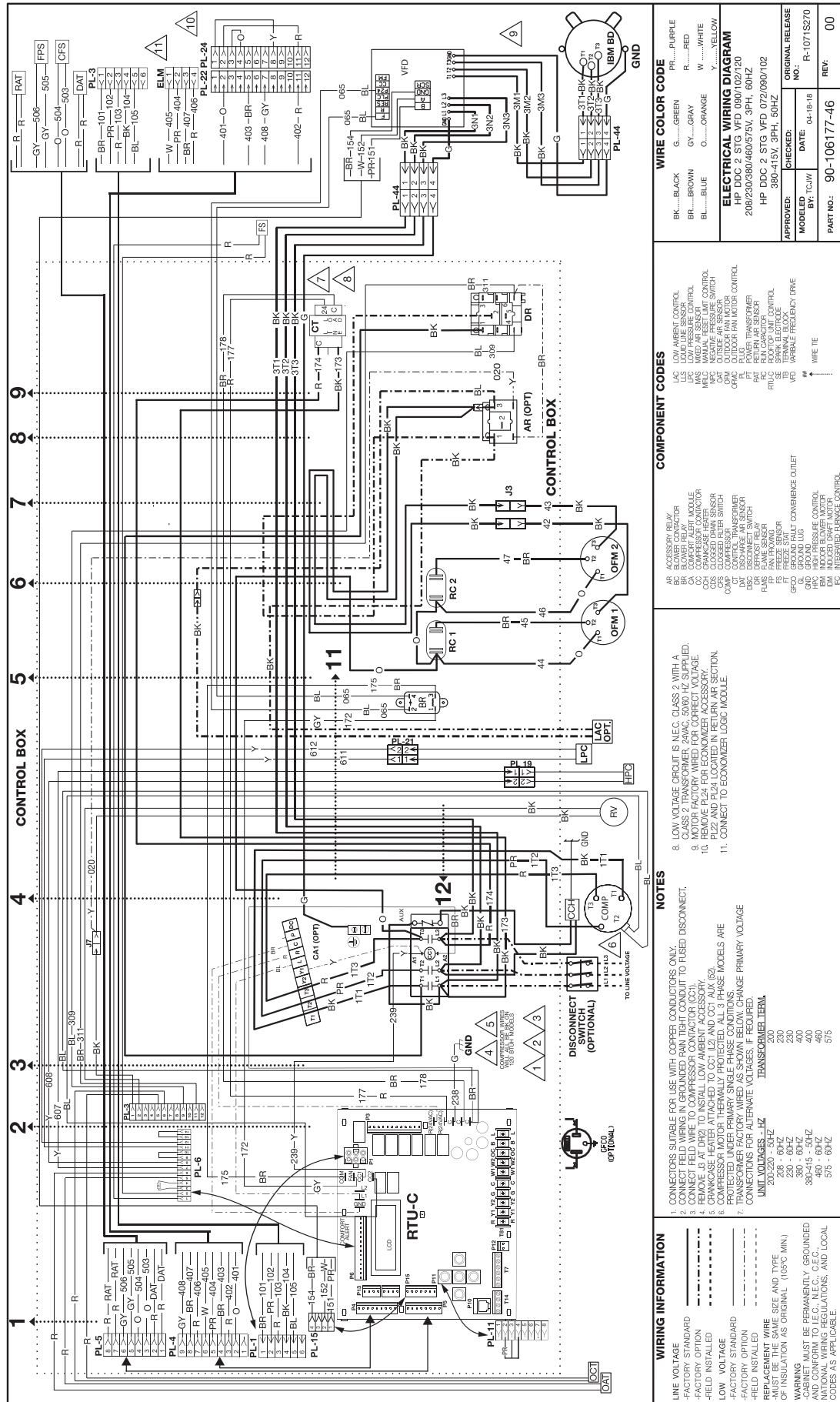
WIRING INFORMATION	
LINE VOLTAGE	STANDARD
-FACTORY STANDARD	STANDARD
-FACTORY OPTION	STANDARD
-FIELD INSTALLED	STANDARD
LOW VOLTAGE	STANDARD
-FACTORY STANDARD	STANDARD
-FACTORY OPTION	STANDARD
-FIELD INSTALLED	STANDARD
REPLACEMENT WIRE	STANDARD
-FACTORY STANDARD	STANDARD
-FACTORY OPTION	STANDARD
-FIELD INSTALLED	STANDARD

WARNING	
CABINET MUST BE PERMANENTLY GROUNDING	
GROUNDING MUST BE PERMANENTLY GROUNDING	
NATIONAL WIRING CODES AND LOCAL CODES AS APPLICABLE.	

PART NO.:	
90-106178-45	
REV:	00



FIGURE 30



**WIRE COLOR CODE**

BK.....BLACK	GY.....GREEN	PR.....PURPLE
BR.....BROWN	GR.....GRAY	R.....RED
BL.....BLUE	O.....ORANGE	W.....WHITE
		Y.....YELLOW

**ELECTRICAL WIRING DIAGRAM**  
 HP DDC 2 STG VFD 080/102/120  
 208/230/380/460/575V, 3PH, 60HZ  
 HP DDC 2 STG VFD 072/090/102  
 380-415V, 3PH, 50HZ

**APPROVED:** \_\_\_\_\_  
**MODELED:** \_\_\_\_\_  
**DATE:** 04-18-18  
**ORIGINAL RELEASE NO.:** R-10715270  
**PART NO.:** 90-106177-46  
**REV.:** 00

**COMPONENT CODES**

AR	ACCESSORY RELAY
BR	BLOWER RELAY
CC	COMPRESSOR CONTACTOR
CCS	COMPRESSOR SAFETY SWITCH
CR	CRANKCASE HEATER
CS	CLOSED RELAY SWITCH
CT	CONTROL TRANSFORMER
DC	DISCONNECT SWITCH
DR	DEFROST RELAY
FP	FAN FRACTION
FT	FREEZE SENSOR
GR	GROUND FAULT CONVENIENCE OUTLET
GS	GROUND LUG
IM	INDUCED DRAFT MOTOR
EM	INDUCTOR BLOWER MOTOR
PC	INSULATED BRIDGE CONTROL

8. LOW VOLTAGE (OP/JIT) IS NEG. CLASS 2 WITH A CLASS 2 TRANSFORMER, 2WAC, 50/60 HZ SUPPLIED.  
 9. MOTOR FIELD WIRING FOR CORRECT VOLTAGE.  
 10. ROOM FAN FOR ECONOMIZER ACCESSORY FUNCTION.  
 11. CONNECT TO ECONOMIZER LOGIC MODULE.

**NOTES**

1. CONNECTORS SUITABLE FOR USE WITH COPPER CONDUCTORS ONLY.  
 2. CONNECT FIELD WIRING IN GROUNDING RAIN TIGHT CONDUIT TO FUSED DISCONNECT.  
 3. CONNECT FIELD WIRING TO COMPRESSOR CONTACTOR SAFELY.  
 4. ROOM FAN IS NOT TO BE USED FOR ECONOMIZER ACCESSORY FUNCTION.  
 5. CRANKCASE HEATER ATTACHED TO CCI (L2) AND CCI AUX (E2).  
 6. COMPRESSOR MOTOR THERMALLY PROTECTED. ALL 3 PHASE MODELS ARE PROTECTED UNDER PRIMARY SINGLE PHASE CONDITIONS.  
 7. DISCONNECT SWITCH IS REQUIRED FOR ALL UNITS. CHANGE PRIMARY VOLTAGE UNIT VOLTAGES - HZ TRANSFORMER TAP.

200-220 - 50HZ	200
208 - 60HZ	230
230 - 60HZ	230
380-415 - 50HZ	400
380-415 - 60HZ	400
460 - 60HZ	460
575 - 60HZ	575

**WIRING INFORMATION**

LINE VOLTAGE \_\_\_\_\_  
 -FACTORY STANDARD \_\_\_\_\_  
 -FACTORY OPTION \_\_\_\_\_  
 -FIELD INSTALLED \_\_\_\_\_

LOW VOLTAGE \_\_\_\_\_  
 -FACTORY STANDARD \_\_\_\_\_  
 -FACTORY OPTION \_\_\_\_\_  
 -FIELD INSTALLED \_\_\_\_\_

REPLACEMENT WIRE SIZE AND TYPE \_\_\_\_\_  
 OF INSULATION AS ORIGINAL (105°C MIN.)

**WARNING**  
 -CABINET MUST BE PERMANENTLY GROUNDING  
 -WIRING MUST BE PERMANENTLY GROUNDING  
 -NATIONAL WIRING REGULATIONS, AND LOCAL CODES AS APPLICABLE.

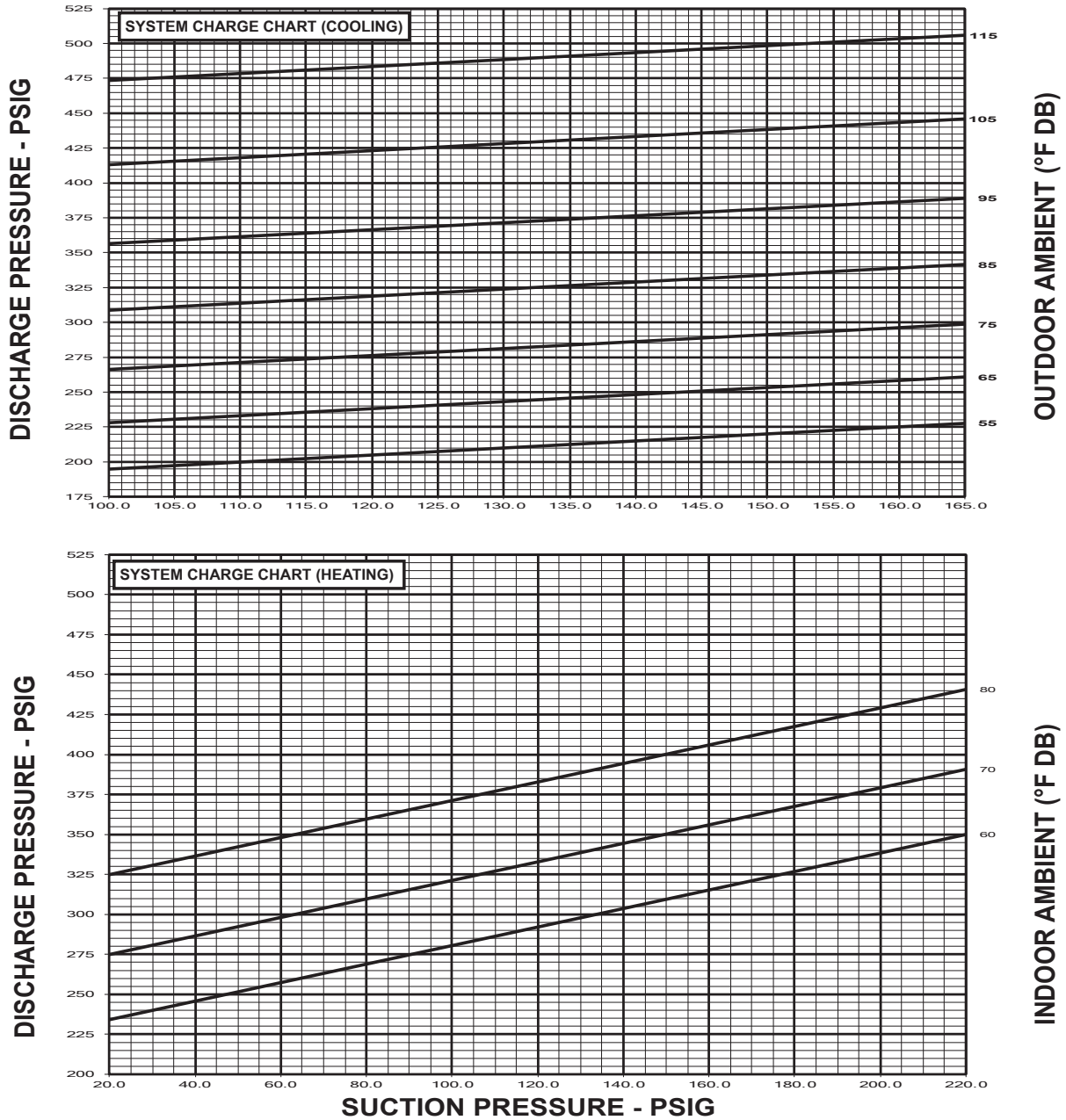




# CHARGING CHARTS

FIGURE 32

7.5 TON HP (R410A)

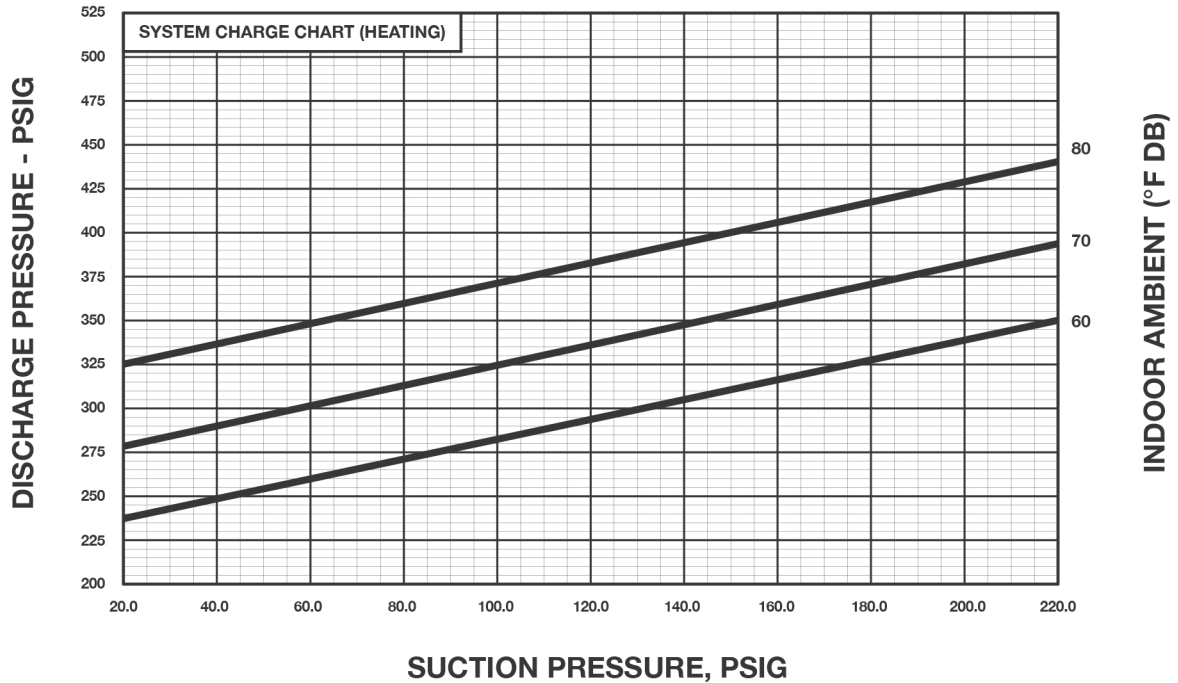
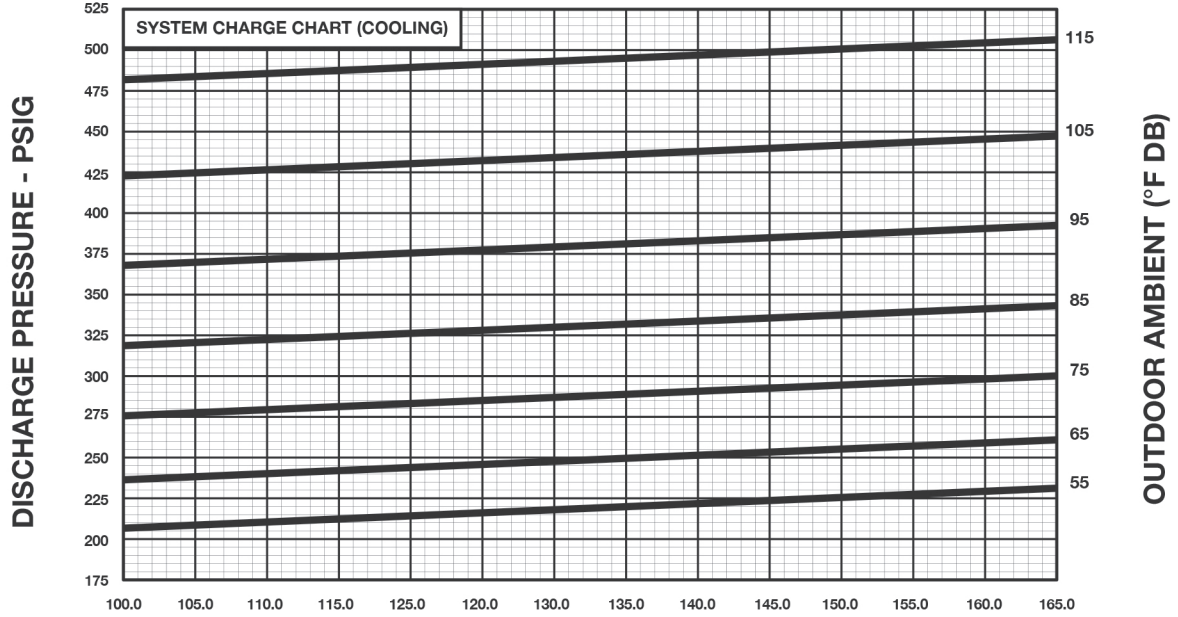


- CAUTION:** 1. RETURN AIR TEMPERATURE MUST BE WITHIN COMFORT CONDITIONS BEFORE FINAL REFRIGERANT CHECK!
- INSTRUCTIONS:** 1. MEASURE PRESSURE AT COMPRESSOR SUCTION AND DISCHARGE.  
 2. MEASURE OUTDOOR AMBIENT TO UNIT.  
 3. PLACE X ON CHART WHERE SUCTION AND DISCHARGE INTERSECT.  
 4. IF X IS BELOW OUTDOOR AMBIENT LINE, ADD CHARGE AND REPEAT STEPS 1-3.  
 5. IF X IS ABOVE OUTDOOR AMBIENT LINE, RECOVER EXCESS CHARGE AND REPEAT STEPS 1-3.

92-106139-01-01

FIGURE 33

8.5 - TON CHARGE CHARTS



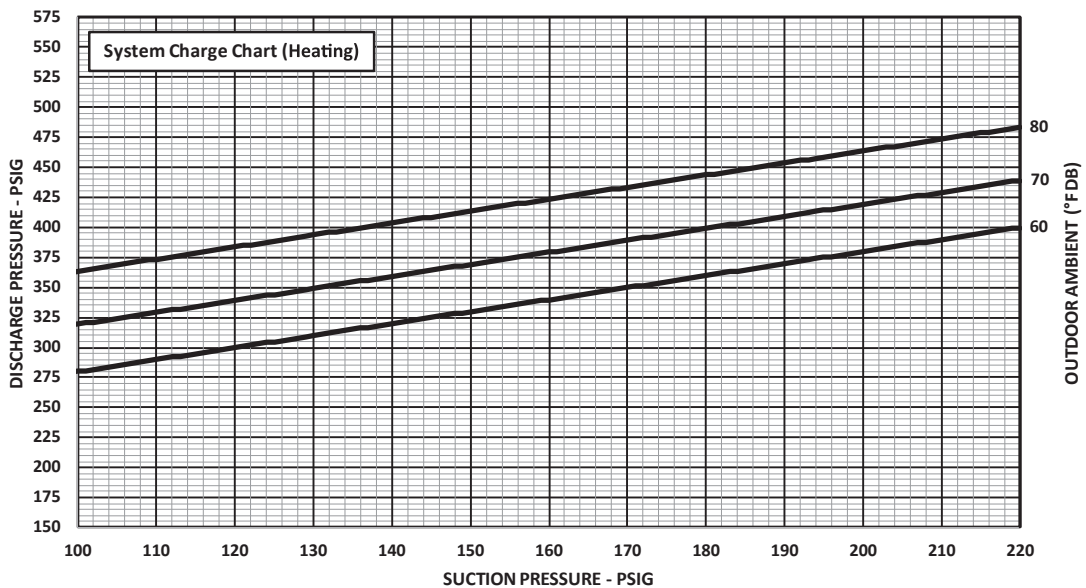
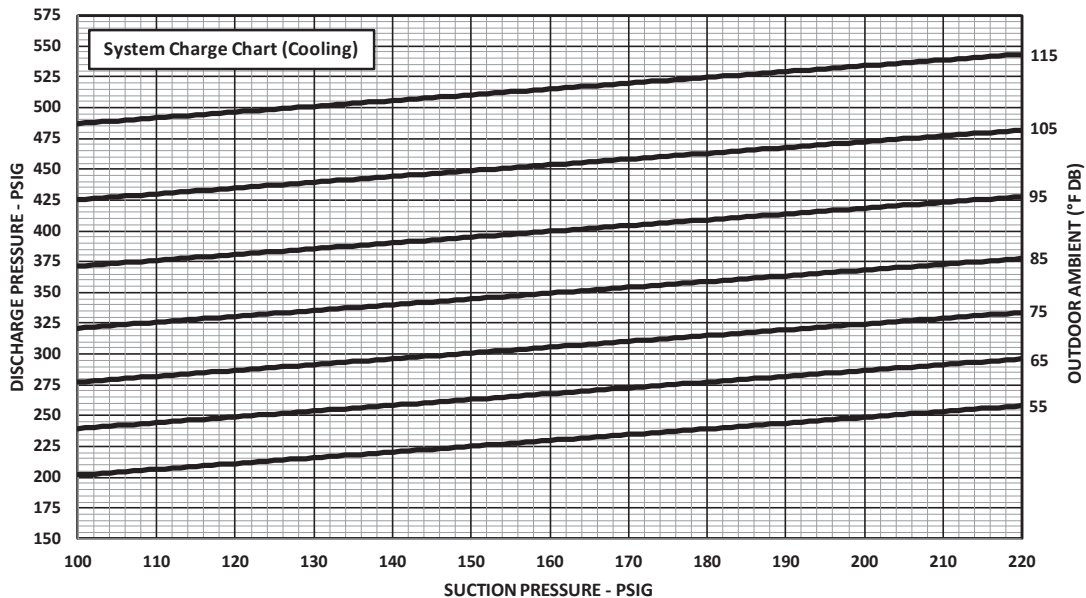
SUCTION PRESSURE, PSIG

- CAUTION:** 1. RETURN AIR TEMPERATURE MUST BE WITHIN COMFORT CONDITIONS BEFORE FINAL REFRIGERANT CHECK!
- INSTRUCTIONS:** 1. MEASURE PRESSURE AT COMPRESSOR SUCTION AND DISCHARGE.  
 2. MEASURE OUTDOOR AMBIENT TO UNIT.  
 3. PLACE X ON CHART WHERE SUCTION AND DISCHARGE INTERSECT.  
 4. IF X IS BELOW OUTDOOR AMBIENT LINE, ADD CHARGE AND REPEAT STEPS 1-3.  
 5. IF X IS ABOVE OUTDOOR AMBIENT LINE, RECOVER EXCESS CHARGE AND REPEAT STEPS 1-3.

92-106139-02-00

**FIGURE 34**

**10.0 TON HP (R410A)**

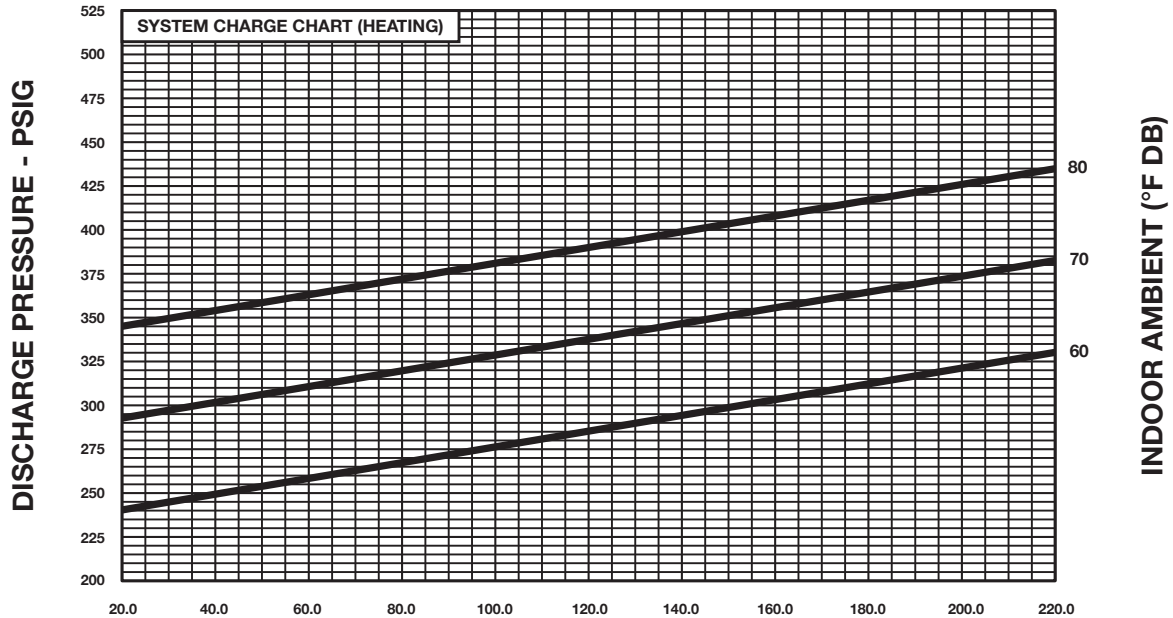
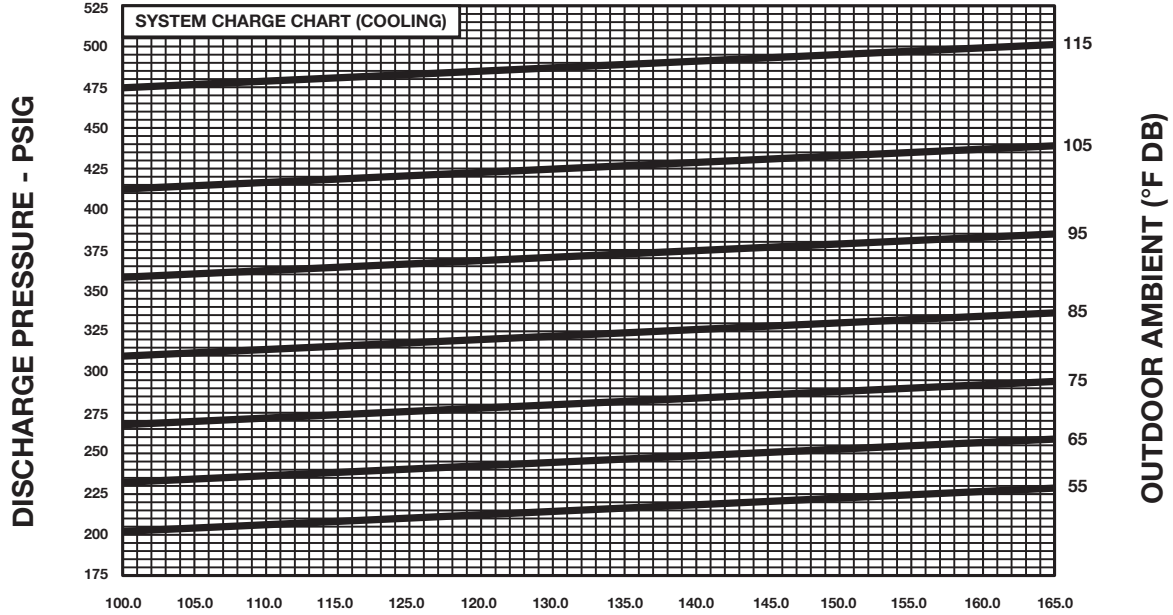


- CAUTION:** 1. RETURN AIR TEMPERATURE MUST BE WITHIN COMFORT CONDITIONS BEFORE FINAL REFRIGERANT CHECK!
- INSTRUCTIONS:**
1. MEASURE PRESSURE AT COMPRESSOR SUCTION AND DISCHARGE.
  2. MEASURE OUTDOOR AMBIENT TO UNIT.
  3. PLACE X ON CHART WHERE SUCTION AND DISCHARGE INTERSECT.
  4. IF X IS BELOW OUTDOOR AMBIENT LINE, ADD CHARGE AND REPEAT STEP 1-3.
  5. IF ABOVE OUTDOOR AMBIENT LINE, RECOVER EXCESS CHARGE AND REPEAT STEPS 1-3.

92-106139-03-02

FIGURE 35

7.5 - TON 2-STAGE CHARGE CHARTS



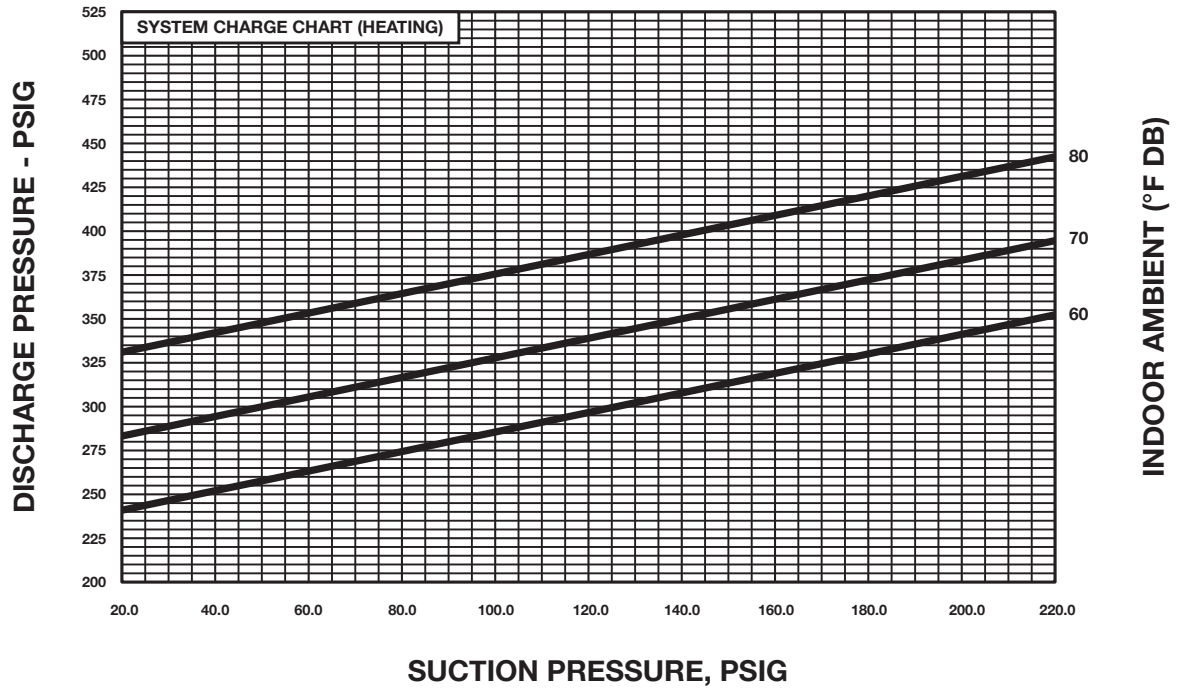
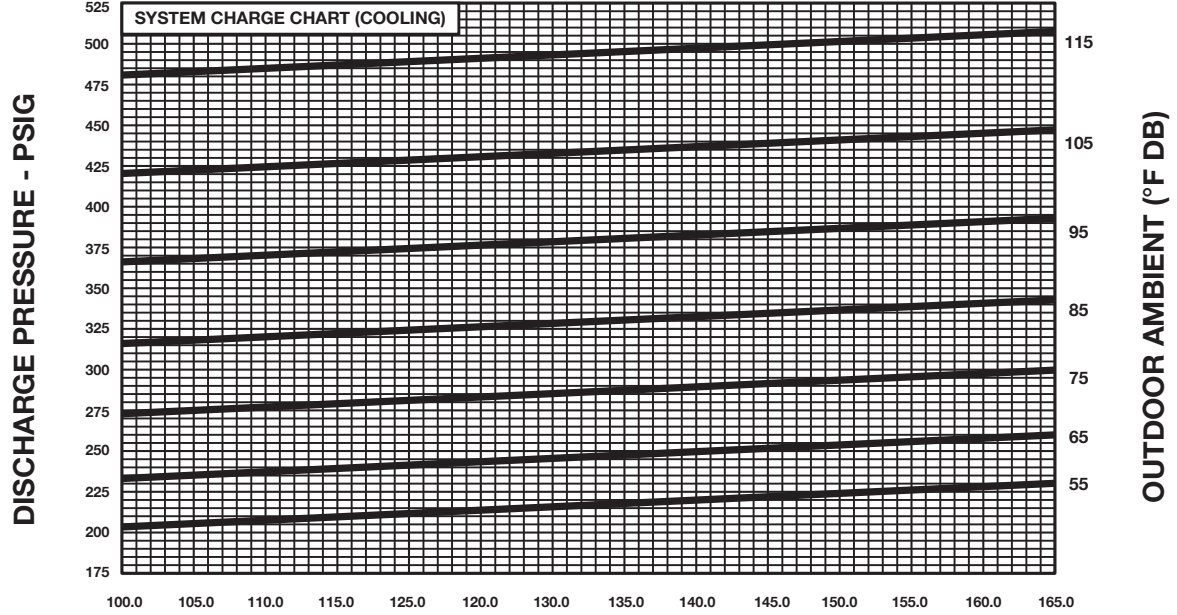
SUCTION PRESSURE, PSIG

- CAUTION:** 1. RETURN AIR TEMPERATURE MUST BE WITHIN COMFORT CONDITIONS BEFORE FINAL REFRIGERANT CHECK!
- INSTRUCTIONS:** 1. MEASURE PRESSURE AT COMPRESSOR SUCTION AND DISCHARGE.  
 2. MEASURE OUTDOOR AMBIENT TO UNIT.  
 3. PLACE X ON CHART WHERE SUCTION AND DISCHARGE INTERSECT.  
 4. IF X IS BELOW OUTDOOR AMBIENT LINE, ADD CHARGE AND REPEAT STEPS 1-3.  
 5. IF X IS ABOVE OUTDOOR AMBIENT LINE, RECOVER EXCESS CHARGE AND REPEAT STEPS 1-3.

92-106139-04-00

FIGURE 36

8.5 - TON 2-STAGE CHARGE CHARTS



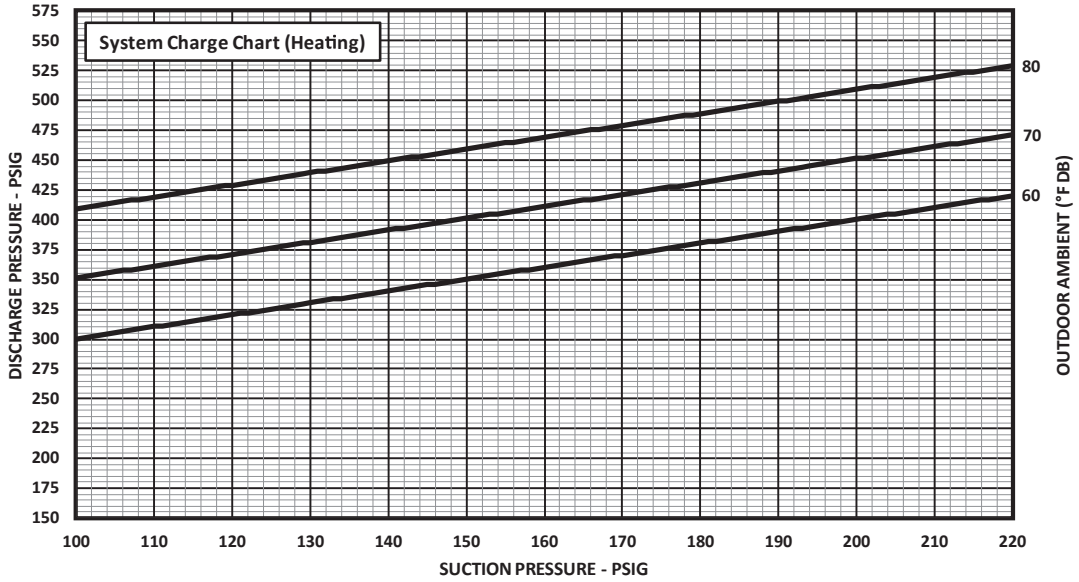
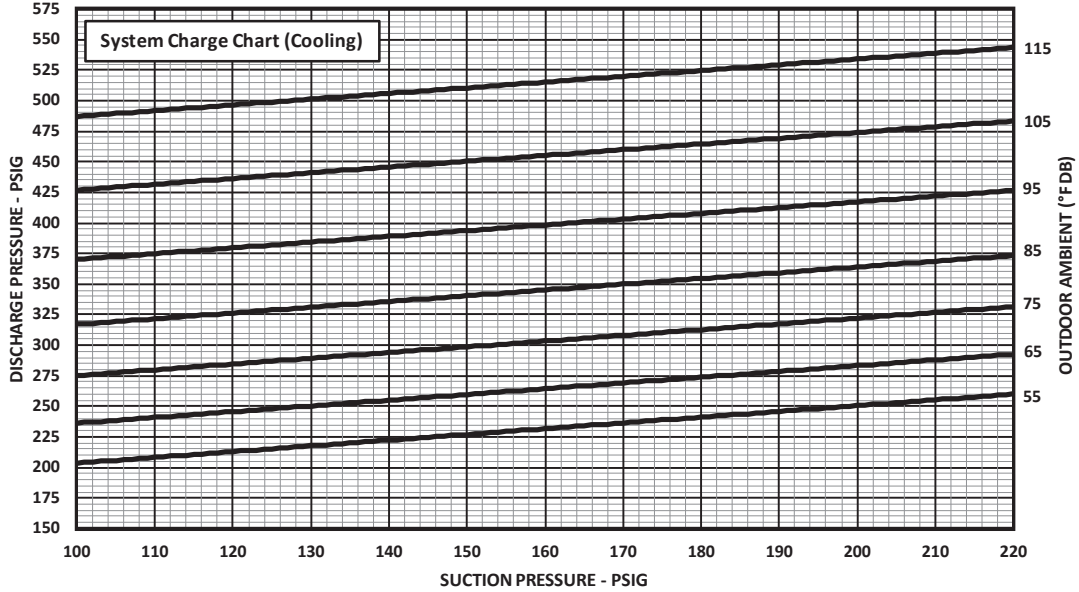
SUCTION PRESSURE, PSIG

- CAUTION: 1. RETURN AIR TEMPERATURE MUST BE WITHIN COMFORT CONDITIONS BEFORE FINAL REFRIGERANT CHECK!**
- INSTRUCTIONS:**
1. MEASURE PRESSURE AT COMPRESSOR SUCTION AND DISCHARGE.
  2. MEASURE OUTDOOR AMBIENT TO UNIT.
  3. PLACE X ON CHART WHERE SUCTION AND DISCHARGE INTERSECT.
  4. IF X IS BELOW OUTDOOR AMBIENT LINE, ADD CHARGE AND REPEAT STEPS 1-3.
  5. IF X IS ABOVE OUTDOOR AMBIENT LINE, RECOVER EXCESS CHARGE AND REPEAT STEPS 1-3.

92-106139-05-00

**FIGURE 37**

**10.0 TON 2-Stage HP (R410A)**



- CAUTION: 1. RETURN AIR TEMPERATURE MUST BE WITHIN COMFORT CONDITIONS BEFORE FINAL REFRIGERANT CHECK!
- INSTRUCTIONS: 1. MEASURE PRESSURE AT COMPRESSOR SUCTION AND DISCHARGE.  
 2. MEASURE OUTDOOR AMBIENT TO UNIT.  
 3. PLACE X ON CHART WHERE SUCTION AND DISCHARGE INTERSECT.  
 4. IF X IS BELOW OUTDOOR AMBIENT LINE, ADD CHARGE AND REPEAT STEP 1-3.  
 5. IF ABOVE OUTDOOR AMBIENT LINE, RECOVER EXCESS CHARGE AND REPEAT STEPS 1-3.
- 92-106139-06-01









*In keeping with its policy of continuous progress and product improvement, Rheem reserves the right to make changes without notice.*

Rheem Heating, Cooling & Water Heating • P.O. Box 17010  
Fort Smith, Arkansas 72917 • [www.rheem.com](http://www.rheem.com)

Rheem Canada Ltd./Ltée • 125 Edgeware Road, Unit 1  
Brampton, Ontario L6Y 0P5