

# INSTALLATION INSTRUCTIONS

## AIR HANDLERS

FEATURING INDUSTRY STANDARD R-410A REFRIGERANT 

(-)H1P Standard Efficiency with Aluminum Coil

(-)H2T High Efficiency with Aluminum Coil (2-Stage Non-Communicating)



**RECOGNIZE THIS SYMBOL AS AN INDICATION OF IMPORTANT SAFETY INFORMATION!**

### **WARNING**

These instructions are intended as an aid to qualified licensed service personnel for proper installation, adjustment and operation of this unit. Read these instructions thoroughly before attempting installation or operation. Failure to follow these instructions may result in improper installation, adjustment, service or maintenance possibly resulting in fire, electrical shock, property damage, personal injury or death.



**ISO 9001:2015**

**DO NOT DESTROY THIS MANUAL**

**PLEASE READ CAREFULLY AND KEEP IN A SAFE PLACE FOR FUTURE REFERENCE BY A SERVICEMAN**

# TABLE OF CONTENTS

<b>1.0 SAFETY INFORMATION</b> .....	<b>4</b>
<b>2.0 GENERAL INFORMATION</b> .....	<b>6</b>
2.1 IMPORTANT INFORMATION ABOUT EFFICIENCY & INDOOR AIR QUALITY .....	6
2.2 CHECKING PRODUCT RECEIVED .....	7
2.3 MODEL NUMBER NOMENCLATURE.....	7
2.4 AVAILABLE MODELS.....	8
2.5 Dimensions & Weight.....	9
2.5.1 DIMENSIONS & WEIGHTS: (-)H1P MODELS .....	9
2.5.2 DIMENSIONS & WEIGHTS: (-)H2T MODELS.....	10
2.6 IMPORTANCE OF PROPER INDOOR/OUTDOOR MATCH-UPS .....	11
2.7 IMPORTANCE OF QUALITY INSTALLATION .....	11
<b>3.0 INSTALLATION</b> .....	<b>11</b>
3.1 TOOLS & REFRIGERANT .....	11
3.1.1 TOOLS REQUIRED FOR INSTALLING AND SERVICING R-410A MODELS.....	11
3.1.2 SPECIFICATIONS OF R-410A.....	11
3.1.3 QUICK-REFERENCE GUIDE FOR R-410A .....	12
3.2 APPLICATIONS AND ORIENTATION.....	12
3.2.1 VERTICAL UPFLOW & HORIZONTAL LEFT DISCHARGE .....	12
3.2.2 VERTICAL DOWNFLOW & HORIZONTAL RIGHT DISCHARGE.....	12
3.2.3 INSTALLATION IN AN UNCONDITIONED SPACE .....	14
3.2.4 INSTALLATION IN MOBILE/MANUFACTURED HOMES .....	15
3.2.5 INSTALLATION IN CORROSIVE ENVIRONMENTS .....	16
3.2.6 SUPPORTING AIR-HANDLER IN HORIZONTAL APPLICATIONS .....	16
3.3 AUXILIARY OVERFLOW PAN .....	16
3.4 CLEARANCES.....	17
3.5 DUCT FLANGES .....	17
3.6 DUCTWORK.....	18
3.7 RETURN AIR FILTER.....	18
3.8 REFRIGERANT LINE CONNECTIONS & CHARGING .....	19
3.8.1 PREPARATION .....	19
3.8.2 LIQUID LINE FILTER DRIER.....	19
3.8.3 BRAZING .....	19
3.8.4 LEAK TESTING .....	19
3.8.5 EVACUATION.....	20
3.8.6 REFRIGERANT CHARGING.....	20
3.9 TXV SENSING BULB ATTACHMENT .....	20
3.10 CONDENSATE DRAIN.....	21
3.11 THERMOSTAT .....	21
3.12 ELECTRICAL WIRING.....	22
3.12.1 CONFIGURING UNIT FOR 208 VOLT POWER.....	22
3.12.2 GROUNDING.....	22
3.12.3 POWER WIRING .....	22
3.12.4 COPPER WIRE SIZE - AWG. (3% VOLTAGE DROP).....	23
3.12.5.1 ELECTRICAL DATA – BLOWER MOTOR ONLY – WITHOUT ELECTRIC HEAT: (-)H1PZ .....	23
3.12.5.2 ELECTRICAL DATA – BLOWER MOTOR ONLY – WITHOUT ELECTRIC HEAT: (-)H2T.....	23
3.12.6.1 ELECTRICAL DATA – WITH ELECTRIC HEAT: (-)H1PZ.....	24
3.12.6.2 ELECTRICAL DATA – WITH ELECTRIC HEAT: (-)H2T .....	27
3.12.7 ELECTRIC HEATER KIT SUPPLEMENTAL INFORMATION .....	30
3.12.8 CONTROL WIRING .....	31
3.13 AIRFLOW.....	31
3.12.9 THERMOSTAT & CONTROL WIRING CONNECTIONS .....	31
3.13.1 GENERAL AIRFLOW OPERATING LIMITS.....	32
3.13.2 SELECTING INDOOR BLOWER MOTOR SPEED .....	32
3.13.2.1 (-)H1P MODELS (PSC MOTOR).....	32
3.13.2.2 (-)H2T MODELS (CONSTANT TORQUE ECM MOTOR) - 2 STAGE AIR-FLOW .....	32
3.13.2.3 (-)H2T MODELS (CONSTANT TORQUE ECM MOTOR) – SINGLE STAGE AIR-FLOW .....	33
3.13.3.1 240V AIRFLOW PERFORMANCE DATA: (-)H1P (PSC MOTOR).....	34
3.13.3.2 115/208V AIRFLOW PERFORMANCE DATA: (-)H1P (PSC MOTOR).....	36

# TABLE OF CONTENTS (continued)

3.13.3.3 115/208/240V AIRFLOW PERFORMANCE DATA: (CONSTANT TORQUE MOTOR).....	38
<b>4.0 START-UP .....</b>	<b>42</b>
4.1 PRE-START CHECKLIST.....	42
4.2 SYSTEM START-UP AND OPERATIONAL CHECK-OUT .....	42
4.3 SEQUENCE OF OPERATION.....	42
4.3.1 COOLING MODE.....	42
4.3.2 ELECTRIC HEAT MODE.....	43
4.3.3 HEAT PUMP HEATING MODE .....	43
4.3.4 SUPPLEMENTAL ELECTRIC HEAT DURING DEFROST.....	43
4.3.5 EMERGENCY HEAT (HEAT PUMP).....	43
4.3.6 THERMOSTAT FAN SETTING.....	43
4.4 CORRECTING ELECTRIC HEAT KW FOR VOLTAGE.....	44
4.5 CALCULATING ELECTRIC HEAT CAPACITY IN BTUH .....	44
4.6 CHECKING INDOOR AIR-FLOW .....	44
4.6.1 ESTIMATING CFM USING EXTERNAL STATIC PRESSURE .....	44
4.6.2 ESTIMATING CFM USING ELECTRIC HEAT TEMPERATURE RISE .....	44
4.7 CHECKING REFRIGERANT CHARGE.....	45
<b>5.0 COMPONENTS &amp; CONTROLS.....</b>	<b>45</b>
5.1 BLOWER MOTOR .....	45
5.2 MOTOR RUN CAPACITOR.....	46
5.3 BLOWER CONTROL.....	46
5.4 BLOWER.....	47
5.5 TRANSFORMER .....	47
5.6 INDOOR COIL ASSEMBLY .....	47
<b>6.0 ACCESSORIES &amp; KITS.....</b>	<b>47</b>
6.1 ELECTRIC RESISTANCE HEATER KITS.....	47
6.2 JUMPER BAR KITS.....	48
6.3 AUXILIARY HORIZONTAL OVERFLOW PANS.....	48
6.4 EXTERNAL FILTER BASES .....	48
6.5 COMBUSTIBLE FLOOR BASES.....	48
6.6 HORIZONTAL ADAPTER KITS .....	49
<b>7.0 MAINTENANCE .....</b>	<b>49</b>
7.1 AIR FILTER.....	49
7.2 INDOOR COIL, DRAIN PAN, DRAIN LINE.....	49
7.3 BLOWER MOTOR AND WHEEL.....	49
7.4 MOTOR LUBRICATION.....	50
7.5 BLOWER ASSEMBLY REMOVAL & REPLACEMENT .....	50
7.6 MOTOR REPLACEMENT.....	50
7.7 BLOWER WHEEL REPLACEMENT .....	51
7.8 REPLACEMENT PARTS .....	51
<b>8.0 DIAGNOSTICS.....</b>	<b>52</b>
<b>9.0 WIRING DIAGRAMS.....</b>	<b>53</b>
9.1 WIRING DIAGRAM (-)H1P – 115V.....	53
9.2 WIRING DIAGRAM (-)H1P – 208/240V.....	54
9.3 WIRING DIAGRAM (-)H2T - 115V.....	55
9.4 WIRING DIAGRAM (-)H2T – 208/240V.....	56

**⚠ WARNING** (SEE SECTION 3.13: ELECTRICAL WIRING)

Disconnect all power to unit before installing or servicing. More than one disconnect switch may be required to de-energize the equipment. Hazardous voltage can cause severe personal injury or death.

**⚠ WARNING** (SEE SECTION 7.5: BLOWER ASSEMBLY REMOVAL & REPLACEMENT)

If removal of the blower assembly is required, all disconnect switches supplying power to the equipment must be de-energized and locked (if not in sight of unit) so the field power wires can be safely removed from the blower assembly. Failure to do so can cause electrical shock resulting in personal injury or death.

**⚠ WARNING**

Because of possible damage to equipment or personal injury, installation, service, and maintenance should be performed by a trained, qualified service personnel. Consumer service is recommended only for filter cleaning/replacement. Never operate the unit with the access panels removed.

# 1.0 SAFETY INFORMATION

**⚠ WARNING**

Duct leaks can create an unbalanced system and draw pollutants such as dirt, dust, fumes and odors into the home causing property damage. Fumes and odors from toxic, volatile or flammable chemicals, as well as automobile exhaust and carbon monoxide (CO), can be drawn into the living space through leaking ducts and unbalanced duct systems causing personal injury or death (see Figure 1).

- If air-moving equipment or ductwork is located in garages or off-garage storage areas - all joints, seams, and openings in the equipment and duct must be sealed to limit the migration of toxic fumes and odors including carbon monoxide from migrating into the living space.
- If air-moving equipment or ductwork is located in spaces containing fuel burning appliances such as water heaters or boilers - all joints, seams, and openings in the equipment and duct must also be sealed to prevent depressurization of the space and possible migration of combustion byproducts including carbon monoxide into the living space.

**⚠ WARNING**

These instructions are intended as an aid to qualified, licensed service personnel for proper installation, adjustment and operation of this unit. Read these instructions thoroughly before attempting installation or operation. Failure to follow these instructions may result in improper installation, adjustment, service or maintenance possibly resulting in fire, electrical shock, property damage, personal injury or death.

**⚠ WARNING** (SEE SECTION 3.2.2: VERTICAL DOWNFLOW)

The RXHB-17, RXHB-21 or RXHB-24 combustible floor base is required when some units with electric heat are applied downflow on combustible flooring. Failure to use the base can cause a fire resulting in property damage, personal injury or death. See **CLEARANCES** for units requiring a combustible floor base. See the accessory section in this manual for combustible floor base RXHB.

**⚠ WARNING** (SEE SECTION 3.13.2: GROUNDING)

The unit must be permanently grounded. Failure to do so can result in electrical shock causing personal injury or death.

**⚠ WARNING** (SEE SECTION 7.0: MAINTENANCE)

Units with circuit breaker(s) meet requirements as a service disconnect switch, however, if access is required to the line side (covered) of the circuit breaker, this side of the breaker(s) will be energized with the breaker(s) de-energized. Contact with the line side can cause electrical shock resulting in personal injury or death.

**⚠ WARNING** (SEE SECTION 3.6: DUCTWORK)

Do not, under any circumstances, connect return ductwork to any other heat producing device such as fireplace insert, stove, etc. Unauthorized use of such devices may result in fire, carbon monoxide poisoning, explosion, personal injury or property damage.

Continued on next page >

## **WARNING**

**PROPOSITION 65:** This appliance contains fiberglass insulation. Respirable particles of fiberglass are known to the State of California to cause cancer.

All manufacturer products meet current Federal **OSHA** Guidelines for safety. California Proposition 65 warnings are required for certain products, which are not covered by the **OSHA** standards.

California's Proposition 65 requires warnings for products sold in California that contain or produce any of over 600 listed chemicals known to the State of California to cause cancer or birth defects such as fiberglass insulation, lead in brass, and combustion products from natural gas.

All "new equipment" shipped for sale in California will have labels stating that the product contains and/or produces Proposition 65 chemicals. Although we have not changed our processes, having the same label on all our products facilitates manufacturing and shipping. We cannot always know "when, or if" products will be sold in the California market.

You may receive inquiries from customers about chemicals found in, or produced by, some of our heating and air-conditioning equipment, or found in natural gas used with some of our products. Listed below are those chemicals and substances commonly associated with similar equipment in our industry and other manufacturers.

- Glass Wool (Fiberglass) Insulation
- Carbon Monoxide (CO).
- Formaldehyde
- Benzene

More details are available at the websites for **OSHA** (Occupational Safety and Health Administration), at [www.osha.gov](http://www.osha.gov) and the State of California's OEHHA (Office of Environmental Health Hazard Assessment), at [www.oehha.org](http://www.oehha.org). Consumer education is important since the chemicals and substances on the list are found in our daily lives. Most consumers are aware that products present safety and health risks, when improperly used, handled and maintained.

## **WARNING** (SEE SECTION 3.7: AIR FILTER)

Do not operate the system without filters. A portion of the dust entrained in the air may temporarily lodge in the duct runs and at the supply registers. Any circulated dust particles could be heated and charred by contact with the heating elements. This residue could soil ceilings, walls, drapes, carpets and other articles in the house.

Soot damage may occur even with filters in place when certain types of candles, oil lamps or standing pilots are burned.

## **WARNING**

The first 36 inches of supply air plenum and ductwork must be constructed of sheet metal as required by NFPA 90B. The supply air plenum or duct must have a solid sheet metal bottom directly under the unit with no openings, registers or flexible air ducts located in it. If flexible supply air ducts are used they may be located only in the vertical walls of a rectangular plenum, a minimum of 6 inches from the solid bottom. Metal plenum or duct may be connected to the combustible floor base, if not, it must be connected to the unit supply duct flanges such that combustible floor or other combustible material is not exposed to the supply air opening from the downflow unit. Exposing combustible (non-metal) material to the supply opening of a downflow unit can cause a fire resulting in property damage, personal injury or death.

### **Exceptions to downflow warnings:**

- Installations on concrete floor slab with supply air plenum and ductwork completely encased in not less than 2 inches of concrete (See NFPA 90B).

## **CAUTION** (SEE SECTION 3.2.2: VERTICAL DOWNFLOW & HORIZONTAL RIGHT DISCHARGE)

Unit must be reconfigured for vertical down or horizontal right supply air discharge applications. The coil must be repositioned so the vertical drainpan is on the bottom for vertical down discharge applications or the horizontal drip pan is below coil for horizontal right discharge applications. Failure to reconfigure the unit for these applications can result in property damage and poor system performance.

## **CAUTION** (SEE SECTION 3.3: AUXILIARY OVERFLOW PAN)

In compliance with recognized codes, an auxiliary drain pan must be installed under all equipment containing evaporator coils that are located in any area of a structure where damage to the building or building contents may occur as a result of an overflow of the coil drain pan or a stoppage in the primary condensate drain piping. See Section 6.3 of this manual for auxiliary horizontal overflow pan accessory information (model RXBM).

## **NOTICE**

When used in cooling applications, excessive sweating may occur when unit is installed in an unconditioned space. This can result in property damage.

## **NOTICE**

Improper installation, or installation not made in accordance with the Underwriters Laboratory (UL) certification or these instructions, can result in unsatisfactory operation and/or dangerous conditions and are not covered by the unit warranty.

## ⚠ NOTICE

Use of this air-handler during construction is not recommended. If operation during construction is absolutely required, the following temporary installation requirements must be followed:

Installation must comply with all Installation Instructions in this manual including the following items:

- Properly sized power supply and circuit breaker/fuse
- Air-handler operating under thermostatic control;
- Return air duct sealed to the air-handler;
- Air filters must be in place;
- Correct air-flow setting for application
- Removing the coil and storing it in a clean safe place is highly recommended until construction is completed and the outdoor unit is installed.
- Clean air-handler, duct work, and components including coil upon completion of the construction process and verify proper air-handler operating conditions according as stated in this instruction manual.
- NOTE: Electric strip heater elements tend to emit a burning odor for a few days if dust has accumulated during construction. Heater elements are easily damaged. Take great care when cleaning them. Low pressure compressed air is recommended for cleaning elements.

**FIGURE 1**  
MIGRATION OF DANGEROUS SUBSTANCES, FUMES, AND ODORS INTO LIVING SPACES

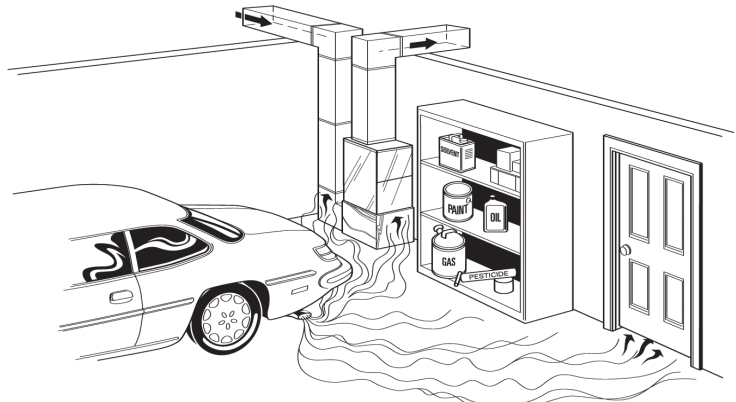

Adapted from *Residential Duct Diagnostics and Repair*, with permission of Air Conditioning Contractors of America (ACCA).

## ⚠ WARNING



### Carbon Monoxide (CO) Poisoning Can Cause Severe Injury or Death.

Carbon Monoxide from the exhaust of motor vehicles and other fuel burning devices can be drawn into the living space by the operation of the central heating and air conditioning system.

Exhaust from motor vehicles, generators, garden tractors, mowers, portable heaters, charcoal and gas grills, gasoline powered tools, and outdoor camping equipment contains carbon monoxide, a poisonous gas that can kill you. You cannot see it, smell it, or taste it.

- Do NOT operate an automobile or any engine in a garage for more than the few seconds it takes to enter or exit the garage.
- Do NOT operate any fuel-burning device in an enclosed or partly enclosed space, or near building windows, doors or air intakes.

The U.S. Consumer Product Safety Commission (CPSC) and Health Canada recommend the installation of UL or CSA certified Carbon Monoxide Alarm(s) in every home.

## ⚠ WARNING

Duct leaks can create an unbalanced system and draw pollutants such as dirt, dust, fumes and odors into the home causing property damage. Fumes and odors from toxic, volatile or flammable chemicals, as well as automobile exhaust and carbon monoxide (CO), can be drawn into the living space through leaking ducts and unbalanced duct systems causing personal injury or death (see Figure 1).

- If air-moving equipment or ductwork is located in garages or off-garage storage areas - all joints, seams, and openings in the equipment and duct must be sealed to limit the migration of toxic fumes and odors including carbon monoxide from migrating into the living space.
- If air-moving equipment or ductwork is located in spaces containing fuel burning appliances such as water heaters or boilers - all joints, seams, and openings in the equipment and duct must also be sealed to prevent depressurization of the space and possible migration of combustion byproducts including carbon monoxide into the living space.

## ⚠ NOTICE

Improper installation, or installation not made in accordance with the Underwriters Laboratory (UL) certification or these instructions, can result in unsatisfactory operation and/or dangerous conditions and are not covered by the unit warranty.

## 2.0 GENERAL INFORMATION

### 2.1 IMPORTANT INFORMATION ABOUT EFFICIENCY & INDOOR AIR QUALITY

Central cooling and heating equipment is only as efficient as the duct system that carries the cooled or heated air. To maintain efficiency, comfort and good indoor air quality,

it is important to have the proper balance between the air being supplied to each room and the air returning to the cooling and heating equipment.

Proper balance and sealing of the duct system improves the efficiency of the heating and air conditioning system and improves the indoor air quality of the home by reducing the amount of airborne pollutants that enter homes from spaces where the ductwork and/or equipment is located. The manufacturer and the U.S. Environmental Protection Agency's Energy Star Program recommend that central duct systems be checked by a qualified contractor for proper balance and sealing.

## 2.2 CHECKING PRODUCT RECEIVED

Immediately upon receipt, all cartons and contents should be inspected for transit damage. Units with damaged cartons should be opened immediately. If damage is found, it should be noted on the delivery documents and a damage claim filed with the delivering carrier.

After unit has been delivered to the job site, remove the unit from the carton taking care not to damage the unit. Check the unit rating plate for unit model number, unit size, coil model, voltage, phase, etc. to assure the unit matches the job specifications.

## 2.3 MODEL NUMBER NOMENCLATURE

**FIGURE 2**  
MODEL NUMBER NOMENCLATURE

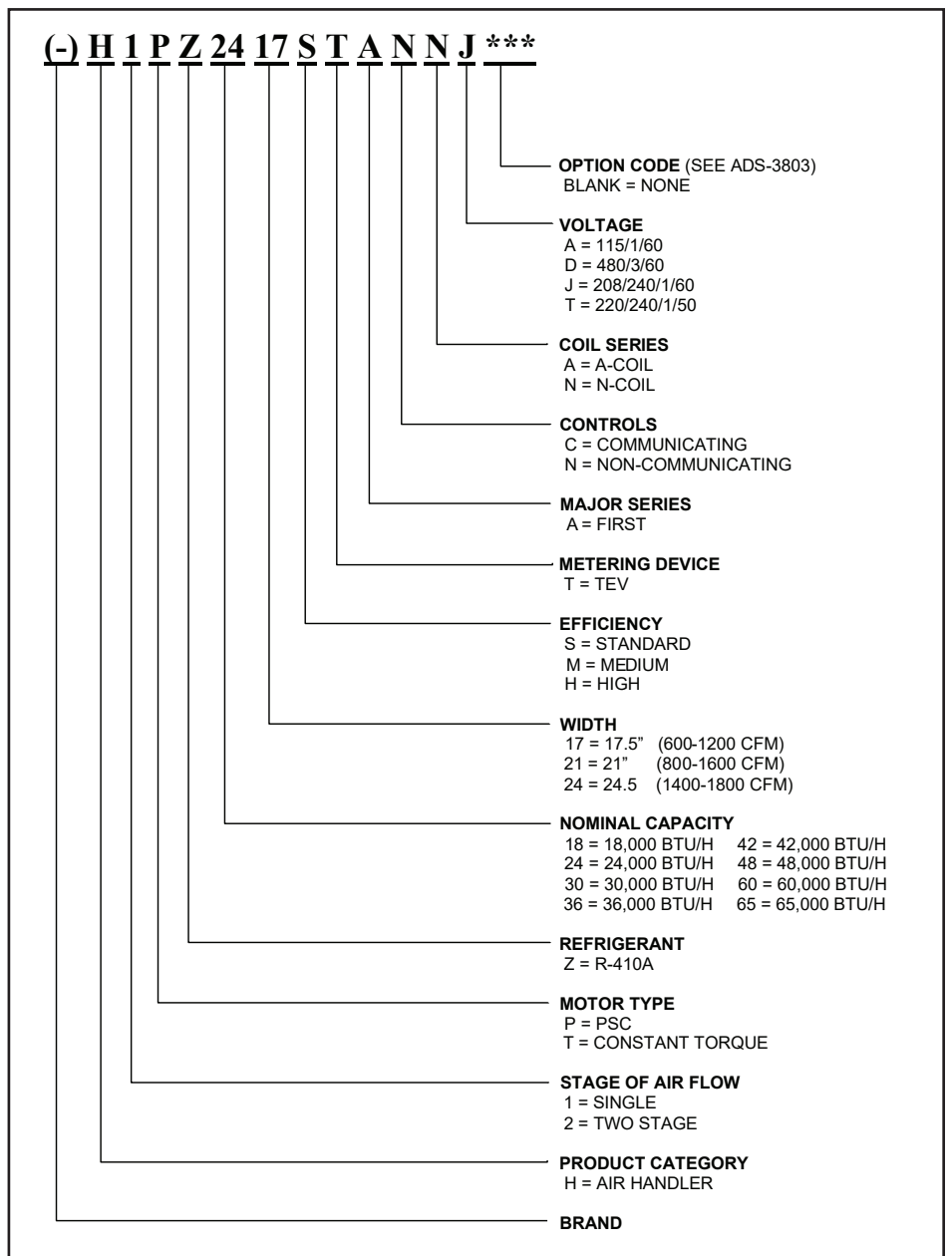

## 2.4 AVAILABLE MODELS

### AVAILABLE 115V MODELS

(-)H1PZ1817STANNA	(-)H2TZ4821STANNA
(-)H2TZ2417STANNA	(-)H1PZ4821STANNA
(-)H1PZ2417STANNA	(-)H2TZ4824STANNA
(-)H1PZ3017STANNA	(-)H2TZ6024STANNA
(-)H2TZ3617STANNA	(-)H2TZ3621MTANAA
(-)H1PZ3617STANNA	(-)H2TZ3621MTANNA
(-)H2TZ3621STANNA	(-)H2TZ4821STANAA
(-)H1PZ3621STANNA	(-)H2TZ6021STANAA
(-)H1PZ4221STANNA	

### AVAILABLE 208/240V MODELS

(-)H1PZ1817STANNJ	(-)H1PZ4824STANNJ
(-)H2TZ2417STANNJ	(-)H2TZ6024STANNJ
(-)H1PZ2417STANNJ	(-)H1PZ6024STANNJ
(-)H1PZ3017STANNJ	(-)H2TZ3621MTANAJ
(-)H2TZ3617STANNJ	(-)H2TZ3621MTANNJ
(-)H1PZ3617STANNJ	(-)H2TZ4821STANAJ
(-)H2TZ3621STANNJ	(-)H2TZ6021STANAJ
(-)H1PZ3621STANNJ	
(-)H1PZ4221STANNJ	
(-)H2TZ4821STANNJ	
(-)H1PZ4821STANNJ	
(-)H2TZ4824STANNJ	

#### Notes:

- J Voltage (208/240V) single phase air handler is designed to be used with single or three phase 208/240V power. When connecting 3-phase power to the air handler terminal block, bring only two leads to the terminal block. Cap, insulate and fully secure the third lead.
- The air handlers are shipped from the factory with the proper indoor coil installed, and cannot be ordered without a coil.
- These air handlers do not have an internal filter rack. An external filter rack or other means of filtration of return air is required.
- Electric resistance heaters are field installed items. (See Section 6.1)



# 2.5 Dimensions & Weight

## 2.5.1 DIMENSIONS & WEIGHTS: (-)H1P MODELS

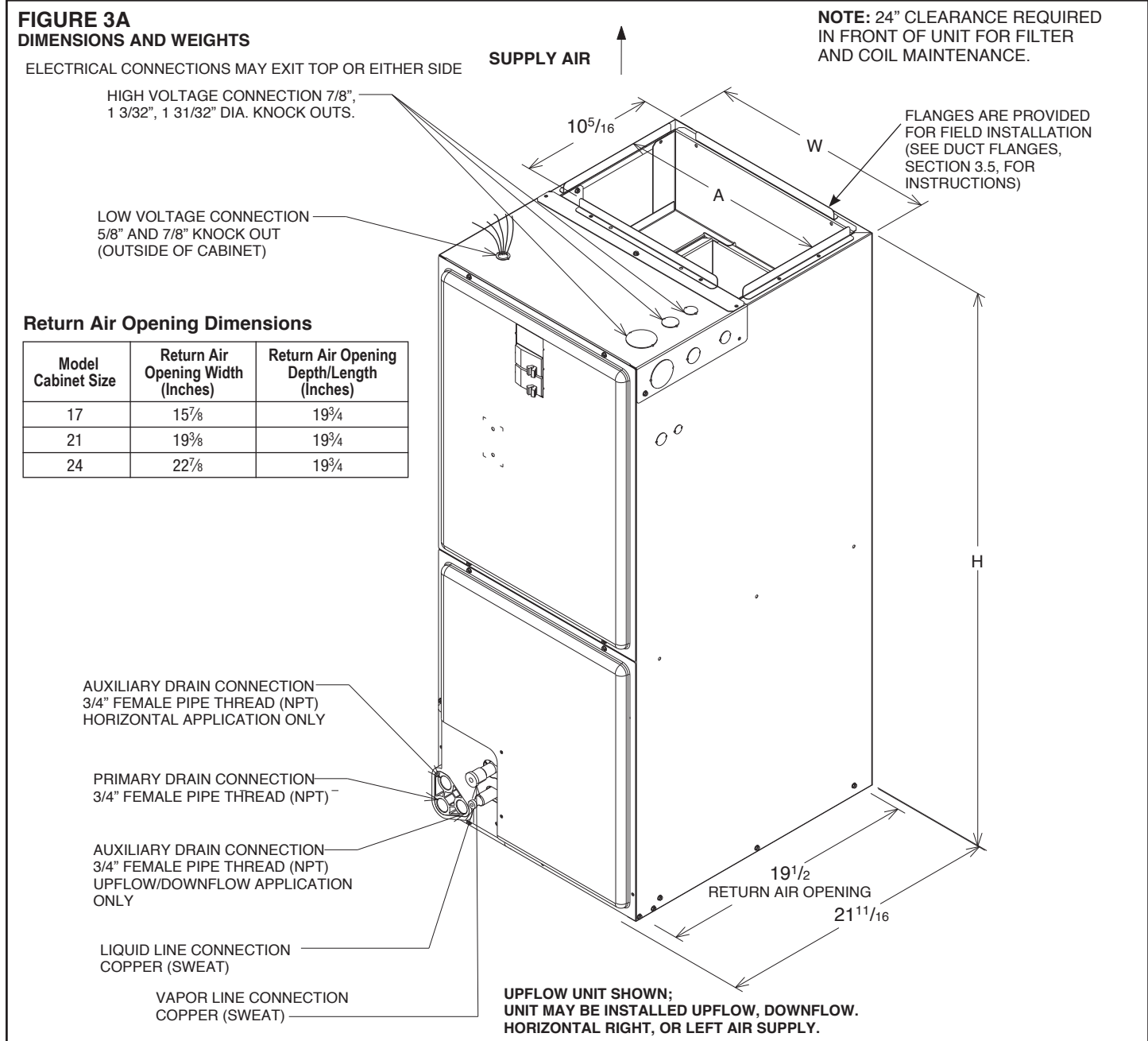

### DIMENSIONAL DATA

MODEL SIZE (-)H1PZ	REFRIGERANT CONNECTIONS		UNIT HEIGHT IN. [mm]	UNIT WIDTH "W" IN. [mm]	SUPPLY DUCT "A" IN. [mm]	UNIT WEIGHT / SHIPPING WEIGHT (LBS.) [kg]
	SWEAT (IN.) [MM] ID					UNIT WITH COIL (MAX. kW.)
	LIQUID	VAPOR				
1817S/2417S	3/8" [9.53]	3/4" [19.05]	42 1/2" [1080]	17 1/2" [444.5]	16" [406.4]	81/95 [37/43]
3017S/3617S	3/8" [9.53]	3/4" [19.05]	42 1/2" [1080]	17 1/2" [444.5]	16" [406.4]	90/104 [41/47]
3621S	3/8" [9.53]	7/8" [22.23]	42 1/2" [1080]	21" [533.4]	19 1/2" [495.3]	109/124 [49/56]
4221S/4821S	3/8" [9.53]	7/8" [22.23]	50 1/2" [1283]	21" [533.4]	19 1/2" [495.3]	130/146 [59/66]
4824S	3/8" [9.53]	7/8" [22.23]	50 1/2" [1283]	24 1/2" [622.3]	23" [584.2]	143/161 [65/73]
6024S	3/8" [9.53]	7/8" [22.23]	55 1/2" [1410]	24 1/2" [622.3]	23" [584.2]	164/181 [75/82]

## 2.5.2 DIMENSIONS & WEIGHTS: (-)H2T MODELS

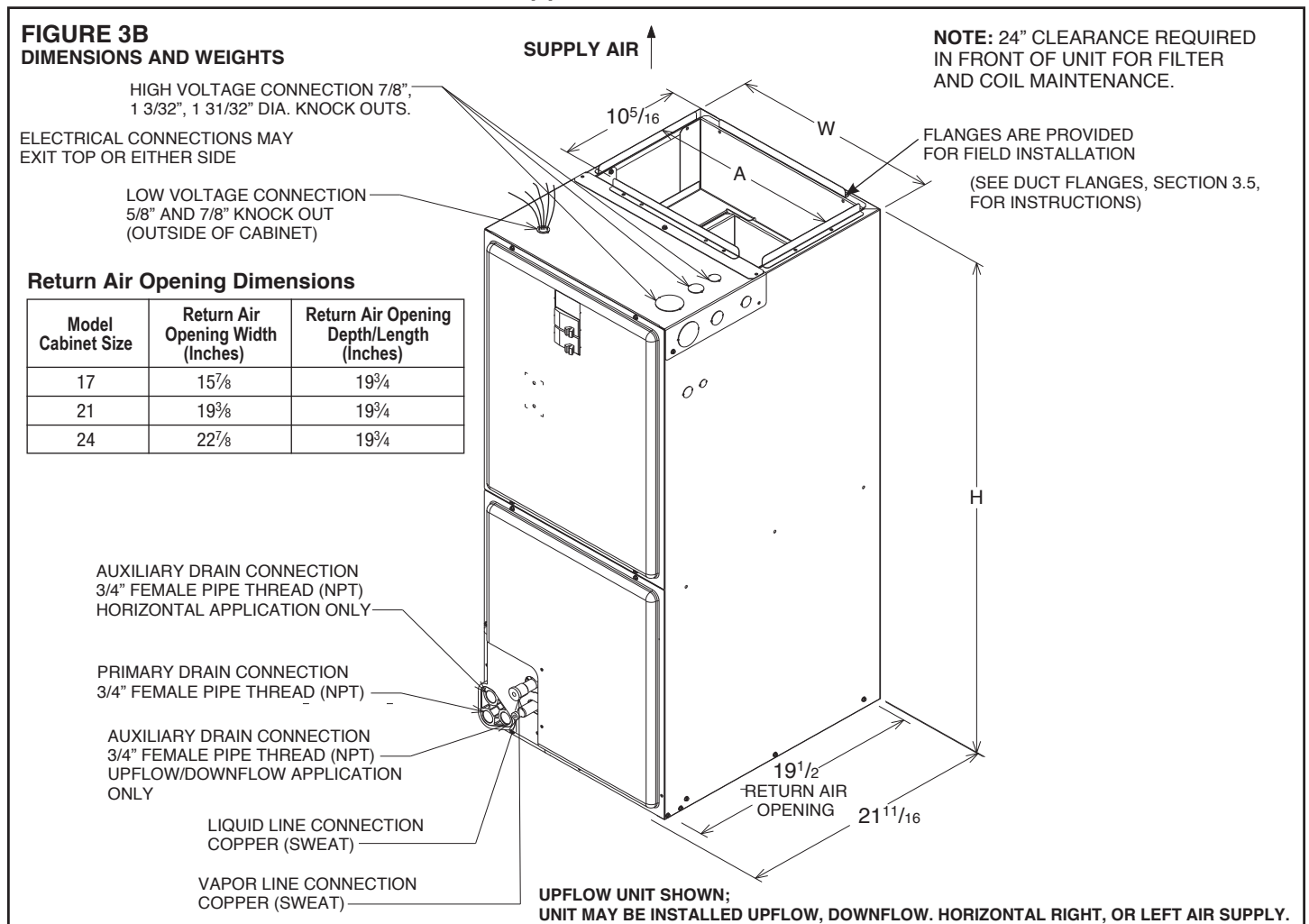

### DIMENSIONAL DATA

MODEL SIZE	REFRIGERANT CONNECTIONS		UNIT HEIGHT IN. [mm]	UNIT WIDTH "W" IN. [mm]	SUPPLY DUCT "A" IN. [mm]	UNIT WEIGHT / SHIPPING WEIGHT (LBS.) [kg]
	SWEAT (IN.) [mm] ID					UNIT WITH COIL (MAX. kW.)
(-)H2TZ	LIQUID	VAPOR				
2417S	<sup>3</sup> / <sub>8</sub> " [9.53]	<sup>3</sup> / <sub>4</sub> " [19.05]	42 <sup>1</sup> / <sub>2</sub> " [1080]	17 <sup>1</sup> / <sub>2</sub> " [445]	16" [409]	92/106 [42/48]
3617S	<sup>3</sup> / <sub>8</sub> " [9.53]	<sup>3</sup> / <sub>4</sub> " [19.05]	42 <sup>1</sup> / <sub>2</sub> " [1080]	17 <sup>1</sup> / <sub>2</sub> " [445]	16" [409]	96/110 [44/50]
3621M	<sup>3</sup> / <sub>8</sub> " [9.53]	<sup>7</sup> / <sub>8</sub> " [22.23]	50 <sup>1</sup> / <sub>2</sub> " [1282]	21" [533]	19 <sup>1</sup> / <sub>2</sub> " [495]	126/142 [57/64]
3621M	<sup>3</sup> / <sub>8</sub> " [9.53]	<sup>7</sup> / <sub>8</sub> " [22.23]	57 [1448]	21" [533]	19 <sup>1</sup> / <sub>2</sub> " [495]	137/149 [62/68]
4821S	<sup>3</sup> / <sub>8</sub> " [9.53]	<sup>7</sup> / <sub>8</sub> " [22.23]	50 <sup>1</sup> / <sub>2</sub> " [1282]	21" [533]	19 <sup>1</sup> / <sub>2</sub> " [495]	128/144 [56/65]
4821S	<sup>3</sup> / <sub>8</sub> " [9.53]	<sup>7</sup> / <sub>8</sub> " [22.23]	57 [1448]	21" [533]	19 <sup>1</sup> / <sub>2</sub> " [495]	139/151 [63/68]
6021S	<sup>3</sup> / <sub>8</sub> " [9.53]	<sup>7</sup> / <sub>8</sub> " [22.23]	57 [1448]	21" [533]	19 <sup>1</sup> / <sub>2</sub> " [495]	139/151 [63/68]
6024S	<sup>3</sup> / <sub>8</sub> " [9.53]	<sup>7</sup> / <sub>8</sub> " [22.23]	55 <sup>1</sup> / <sub>2</sub> " [1410]	24 <sup>1</sup> / <sub>2</sub> " [622]	159/176 [72/80]	159/176 [72/80]
4824S	<sup>3</sup> / <sub>8</sub> " [9.53]	<sup>7</sup> / <sub>8</sub> " [22.23]	55 <sup>1</sup> / <sub>2</sub> " [1410]	24 <sup>1</sup> / <sub>2</sub> " [622]	23" [585]	128/146 [58/66]

## 2.6 IMPORTANCE OF PROPER INDOOR/OUTDOOR MATCH-UPS

To assure many years of reliable operation and optimum customer comfort and to assure the outdoor unit warranty remains valid, an air-handler model should be selected that is properly matched to the outdoor unit. This is especially critical for heat pump systems to assure proper refrigerant charge balance between the cooling and heating modes. The recommended approach is to select an air-handler model that has an AHRI match with the outdoor unit. Refer to the AHRI directory at [www.ahridirectory.org](http://www.ahridirectory.org) to confirm the air-handler and outdoor unit are a certified combination in the AHRI Directory.

## 2.7 IMPORTANCE OF QUALITY INSTALLATION

A quality installation is critical to assure safety, reliability, comfort, and customer satisfaction. Strict adherence to applicable codes, the information in this installation manual, the outdoor unit installation manual, and the thermostat installation manual are key to a quality installation. Read the entire instruction manuals before starting the installation.

**IMPORTANT:** This product has been designed and manufactured to meet certified AHRI capacity and efficiency ratings with the appropriate outdoor units. However, proper refrigerant charge, proper airflow, and refrigerant line sizing are critical to achieve optimum capacity and efficiency and to assure reliable operation. Installation of this product should follow the manufacturer's refrigerant charging and airflow instructions located in the outdoor unit installation instructions and the charging chart label affixed to the outdoor unit. Failure to confirm proper charge and airflow may reduce energy efficiency and shorten equipment life.

The equipment has been evaluated in accordance with the Code of Federal Regulations, Chapter XX, Part 3280.

Install the unit in accordance with applicable national, state, and local codes. Latest editions are available from: "National Fire Protection Association, Inc., Batterymarch Park, Quincy, MA 02269." These publications are:

- ANSI/NFPA No. 70-(Latest Edition) National Electrical Code.
- NFPA90A Installation of Air Conditioning and Ventilating Systems.
- NFPA90B Installation of warm air heating and air conditioning systems.

Install the unit in such a way as to allow necessary access to the coil/filter rack and blower/control compartment.

# 3.0 INSTALLATION

## 3.1 TOOLS & REFRIGERANT

### 3.1.1 TOOLS REQUIRED FOR INSTALLING AND SERVICING R-410A MODELS

#### Manifold Sets:

- Up to 800 PSIG High-Side
- Up to 250 PSIG Low-Side
- 550 PSIG Low-Side Retard

#### Manifold Hoses:

- Service Pressure Rating of 800 PSIG

#### Recovery Cylinders:

- 400 PSIG Pressure Rating
- Dept. of Transportation 4BA400 or BW400

**▲ NOTICE**

R-410A systems operate at higher pressures than R-22 systems. Do not use R-22 service equipment or components on R-410A equipment.

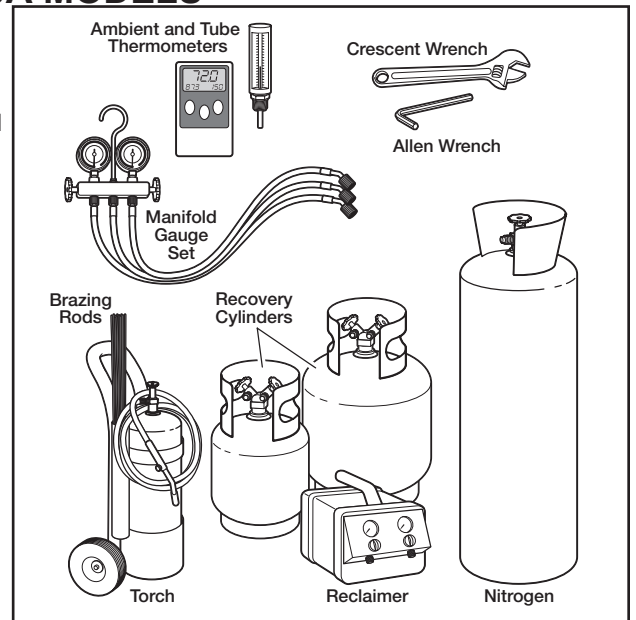

### 3.1.2 SPECIFICATIONS OF R-410A

**Application:** R-410A is not a drop-in replacement for R-22. Equipment designs must accommodate its higher pressures. It cannot be retrofitted into R-22 heat pumps.

**Physical Properties:** R-410A has an atmospheric boiling point of -62.9°F [-52.7°C] and its saturation pressure at 77°F [25°C] is 224.5 psig.

**Composition:** R-410A is a near-azeotropic mixture of 50% by weight difluoromethane (HFC-32) and 50% by weight pentafluoroethane (HFC-125).

**Pressure: The pressure of R-410A is approximately 60% (1.6 times) greater than R-22.** Recovery and recycle equipment, pumps, hoses, and the like must have design pressure ratings appropriate for R-410A. Manifold sets need to range up to 800 psig high-side and 250 psig low-side with a 550 psig low-side retard. Hoses need to have a service pressure rating of 800 psig. Recovery cylinders need to have a 400 psig service pressure rating, DOT 4BA400 or DOT BW400.

**Combustibility:** At pressures above 1 atmosphere, a mixture of R-410A and air can become combustible. **R-410A and air should never be mixed in tanks or supply lines or be allowed to accumulate in storage tanks. Leak checking should never be done with a mixture of R-410A and air.** Leak-checking can be performed safely with nitrogen or a mixture of R-410A and nitrogen.

### 3.1.3 QUICK-REFERENCE GUIDE FOR R-410A

- R-410A refrigerant operates at approximately 60% higher pressure (1.6 times) than R-22. Ensure that servicing equipment is designed to operate with R-410A.
- R-410A refrigerant cylinders are light rose in color.
- R-410A, as with other HFCs, is only compatible with POE oils.
- Vacuum pumps will not remove moisture from POE oil used in R-410A systems.
- R-410A systems are to be charged with liquid refrigerants. Prior to March 1999, R-410A refrigerant cylinders had a dip tube. These cylinders should be kept upright for equipment charging. Post-March 1999 cylinders do not have a dip tube and should be inverted to ensure liquid charging of the equipment.
- Do not install a suction line filter drier in the liquid line.
- A factory-approved outdoor liquid line filter drier is shipped with every unit and must be installed in the liquid line at the time of installation. If only the air-handler is being replaced on an existing system, the existing filter drier must be replaced at the time of installation with a field supplied filter drier. **IMPORTANT:** A bi-flow filter drier must be used for heat pump applications. Filter driers must be rated for minimum working pressure of 600 psig. The filter drier will only have adequate moisture-holding capacity if the system is properly evacuated.
- Desiccant (drying agent) must be compatible for POE oils and R-410A refrigerant.

## 3.2 APPLICATIONS AND ORIENTATION

### 3.2.1 VERTICAL UPFLOW & HORIZONTAL LEFT

#### DISCHARGE

- Vertical Upflow & Horizontal Left Discharge is the factory configuration for all models (see Figure 4).
- The return air plenum must be large enough to supply unit and strong enough to support unit weight.
- If return air is to be ducted through the floor, install duct flush with floor. Use fire-proof resilient gasket 1/8 to 1/4 in. thick between duct, unit and floor. Set unit on floor over opening.

**IMPORTANT:** Do not cut the side out of air-handler cabinet for a side return duct as this will result in the return air bypassing the coil. Instead, install air-handler on top of a field supplied sheet metal or wooden box and run the side return duct into the side of the box.

### 3.2.2 VERTICAL DOWNFLOW & HORIZONTAL RIGHT DISCHARGE

The unit as shipped from the factory is not configured for vertical down or horizontal right discharge applications and must be converted in the field to work in those applications. To make this conversion, remove the coil door and slide the indoor coil out of the cabinet.

When converting the air-handler for vertical down and horizontal right discharge applications, an additional set of 2 coil support rails must be installed before the coil can be reinstalled. These additional rails are supplied with the air-handler and are packaged with the duct flanges. Six screws are also provided for mounting the rails and can be found in the installation hardware bag. Clearance holes must be drilled in the sides of the cabinet for the mounting screws using the provided dimples as guides. Note that the shorter coil support rail with no notch must be mounted on the left-hand side to provide clearance for the drainpan condensate connection boss.

The vertical down/horizontal right coil support rails were not installed at the factory so the insulation under them would not be compressed which could result in exterior cabinet sweating in humid environments due to that location being in the cold downstream side of the indoor coil in vertical up and horizontal left discharge applications. The coil

**FIGURE 4**  
**DIMENSIONS FOR REFRIGERANT-TUBING & DRAIN CONNECTIONS**

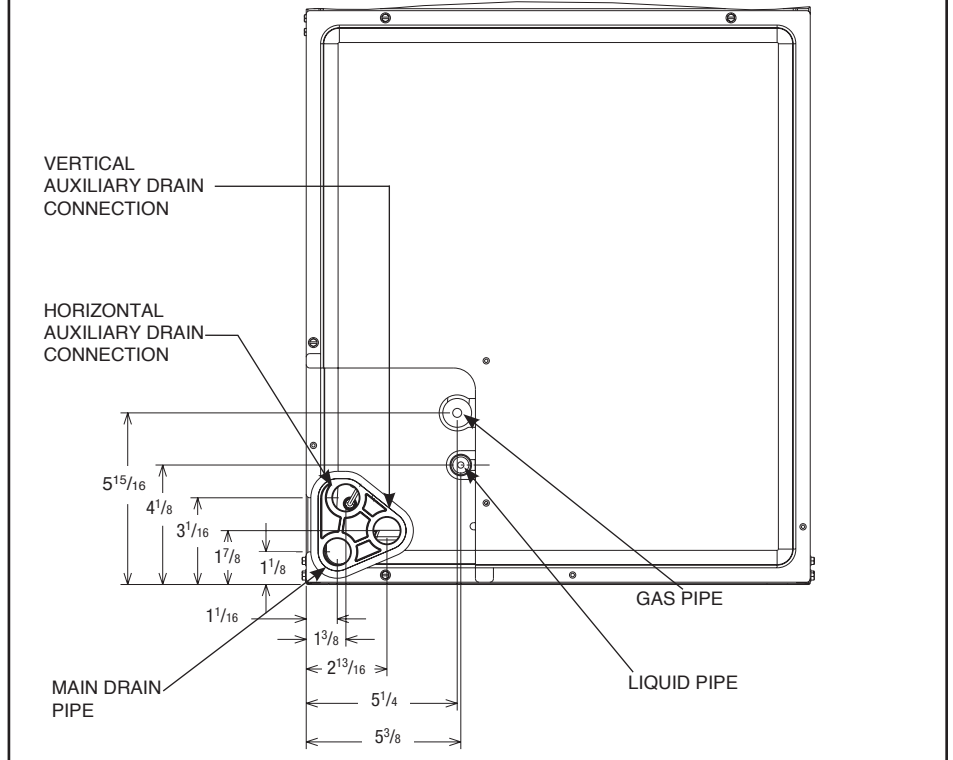

support rails installed at the factory should be left in place to help retain the cabinet insulation. They will be located on the warmer return side of the air-handler for down and horizontal right discharge applications and will therefore not pose a risk for cabinet sweating.

Once the additional coils support rails are installed, slide the coil back into the cabinet 180° from its original position, ensuring the retaining channel is fully engaged with the coil rail. (See Figure 6, Detail A.) Leave the coil door off until after the refrigerant tubing is brazed to the refrigerant stubs to allow TXV to be wrapped with a wet rag or heat sink compound during the brazing process. If the air-handler is not already in position, it can now be positioned so the blower discharge is either down or to the right depending on the application.

**FIGURE 5**  
**ROTATING CIRCUIT BREAKER**

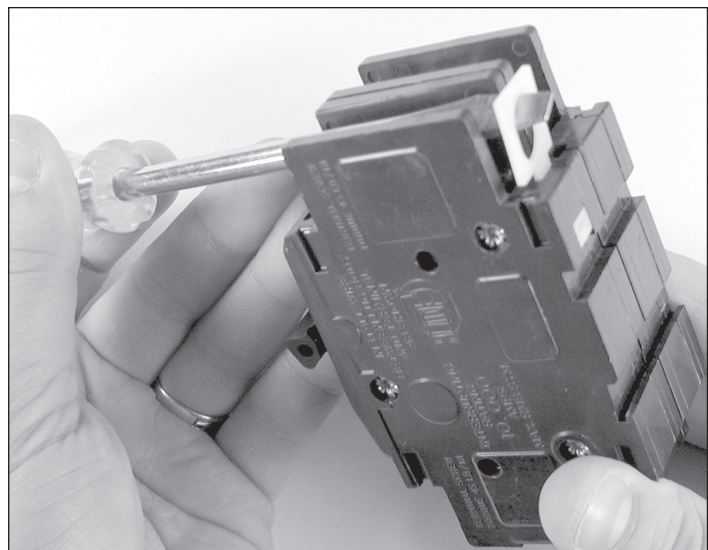

**DRIP LOOP NOTE:** When installing the unit in down or horizontal right discharge applications, make sure the wires going to the blower motor form a proper drip loop to force any condensate that might form on the wires to drip off the lowest point of the wiring instead of entering the motor or motor control. This may require cutting the wire-tie and installing a new wire-tie to form a new drip loop.

**IMPORTANT:** To comply with certification agencies and the National Electric Code for down discharge applications, the circuit breaker(s) on field-installed electric heater kits must be re-installed per procedure below so that the breaker switch “on” position and marking is up and the “off” position and marking is down.

1. To turn breaker(s): Rotate one breaker pair (circuit) at a time starting with the one on the right. Loosen both lugs on the load side of the breaker. Wires are bundles with wire ties, one bundle going to the right lug and one bundle going to the left lug.
2. Using a screwdriver or pencil, lift white plastic tab with hole away from breaker until breaker releases from mounting opening (see Figure 5).
3. With breaker held in hand, rotate breaker so that “on” position is up and the “off” position is down with unit in the vertical mounting position. Insert right wire bundle into top right breaker lug, ensuring all strands of all wires are inserted fully into lug, and no wire insulation is caught in lug.
4. Tighten lug as tight as possible while holding circuit breaker. Check wires and make sure each wire is secure and none are loose. Repeat for left wire bundle in left top circuit breaker lug.

**IMPORTANT:** Failure to securely hold the breaker will result in the plastic mounting boss on the breaker to be broken off when the lug is tightened.

1. Replace breaker by inserting breaker mounting tab opposite white pull tab in opening, hook mounting tab over edge in opening.
2. With screwdriver or pencil, pull white tab with hole away from breaker while setting that side of breaker into opening. When breaker is in place, release tab, locking circuit breaker into location in opening.
3. Repeat above operation for remaining breaker(s) (if more than one is provided).
4. If one is used, replace the single point wiring jumper bar on line side of breaker and tighten securely.
5. Double check wires and lugs to make sure all are secure and tight. Check to make sure unit wiring to circuit breaker load lugs match that shown on the unit wiring diagram.

### **WARNING**

**The RXHB-17, RXHB-21 or RXHB-24 combustible floor base is required when some units with electric heat are applied downflow on combustible flooring. Failure to use the base can cause a fire resulting in property damage, personal injury or death. See CLEARANCES (Section 3.4) for units requiring a combustible floor base. See the accessory section in this manual for combustible floor base RXHB.**

**IMPORTANT:** Units cannot be installed horizontally laying on or suspended from the back of the unit.

### **3.2.3 INSTALLATION IN AN UNCONDITIONED SPACE**

The exterior cabinet of an air handler has a greater risk of sweating when installed in an unconditioned space than when it is installed in the conditioned space. This is primarily due to the temperature of the conditioned air moving through the air handler and the air circulating around the unit where it is installed. For this reason, the following is recommended for all air handler applications, but special attention should be paid to those installed in unconditioned spaces:

- Duct sizing and airflow are critical and must be based on the equipment selected.
- Supply and return duct attachment: If other than the factory flanges are used, the attachment of ducting must be insulated and tight to prevent sweating.
- No perimeter supply flanges are provided. If a full perimeter supply duct is used, it is the responsibility of the installer to provide duct flanges as needed, to secure and seal the supply duct to prevent air leakage and the sweating that will result.
- Apply caulking around all cabinet penetrations such as power wires, control wires, refrigerant tubing and condensate line where they enter the cabinet. Seal the power wires on the inside where they exit conduit opening. Sealing is required to prevent air leakage into the unit which can result in condensate forming inside the unit, control box, and on electrical controls. Take care not to damage, remove or compress insulation when applying the caulk.
- In some cases, the entire air handler can be wrapped with insulation. This can be done as long as the unit is completely enclosed in insulation, sealed and service access is provided to prevent accumulation of moisture inside the insulation wrap.
- An auxiliary overflow pan is recommended to protect the structure from excessive cabinet sweating or a restricted coil drain line. (See Section 3.3)
- If an electric heater kit is installed, be sure the breaker or disconnect cover is sealed tightly to the door panel.

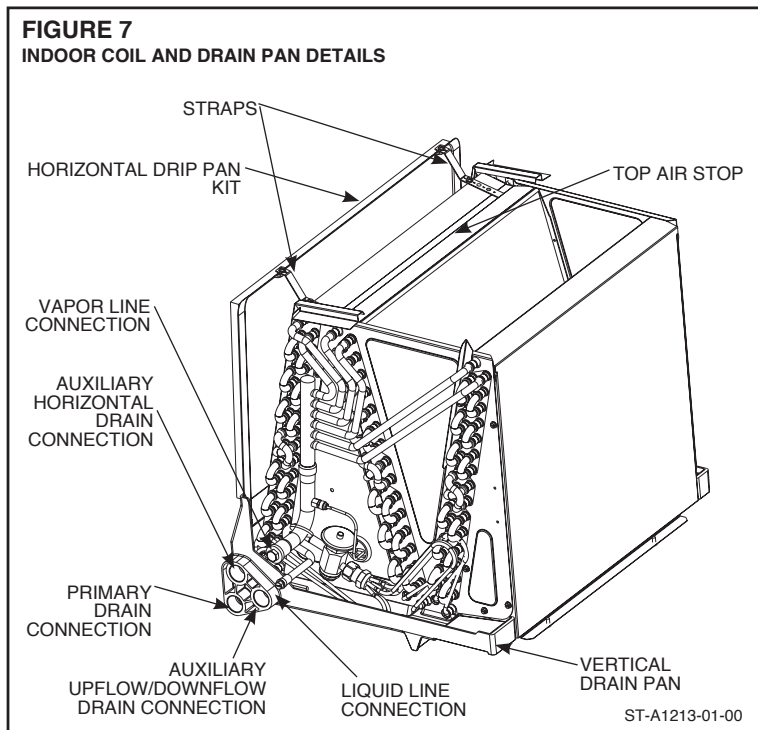
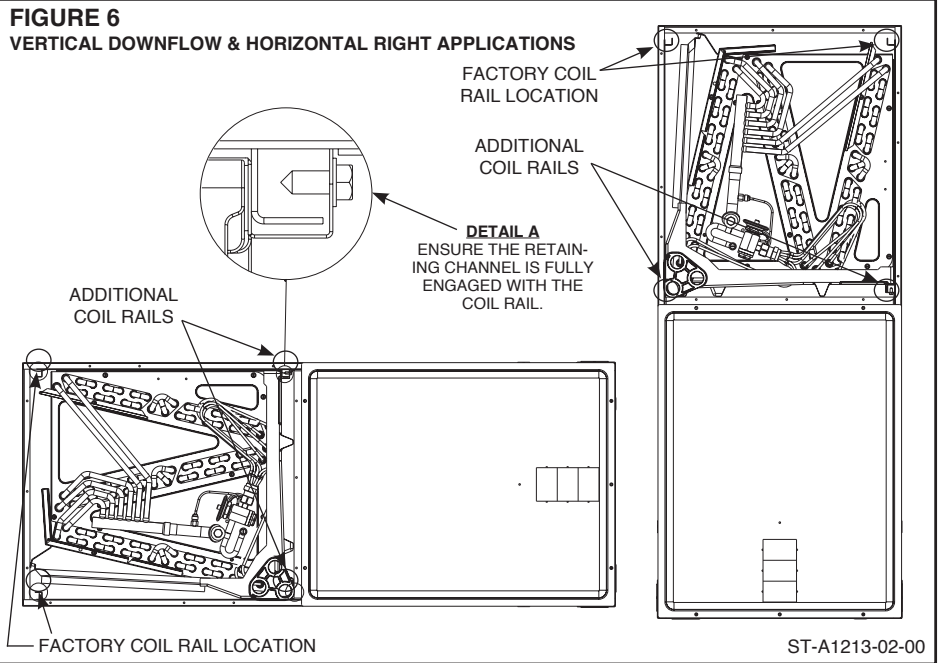

**CAUTION**

Auxiliary horizontal overflow pan kits RXBM- (or equivalent) are required when the unit is configured for the horizontal position over a finished ceiling and/or living space. (See Sections 3.3 and 6.3.) Failure to install overflow pan can result in property damage.

**3.2.4 INSTALLATION IN MOBILE/MANUFACTURED HOMES**

1. Air handler must be secured to the structure using “L” brackets or pipe strap.
2. Allow a minimum of 24 inches (610 mm) front clearance required to access doors.
3. Recommended method for securing air handler:
  - A. If air handler is against the wall, secure top of air handler to wall stud using two 16ga thick angle brackets one on each side. Attach brackets with No. 10 self-tapping 1/2” long screws to air handler and use 5/16” lag screws 1 1/2” long to wall stud. Secure bottom of unit with two 16ga “L” brackets with No. 10 self-tapping 1/2” long

screws to air handler and use  $\frac{5}{16}$ " lag screws  $1\frac{1}{2}$ " long to floor.

- B. If air handler is away from wall attach pipe strap to top of air handler using No. 10  $\frac{1}{2}$ " long self-tapping screws on both sides. Angle strap down and away from back of air handler, remove all slack, and fasten to wall stud of structure using  $\frac{5}{16}$ " lag screws  $1\frac{1}{2}$ " long. Secure bottom of unit with two 16ga "L" brackets with No. 10 self-tapping screws to air handler and use  $\frac{5}{16}$ " lag screws  $1\frac{1}{2}$ " long to floor.

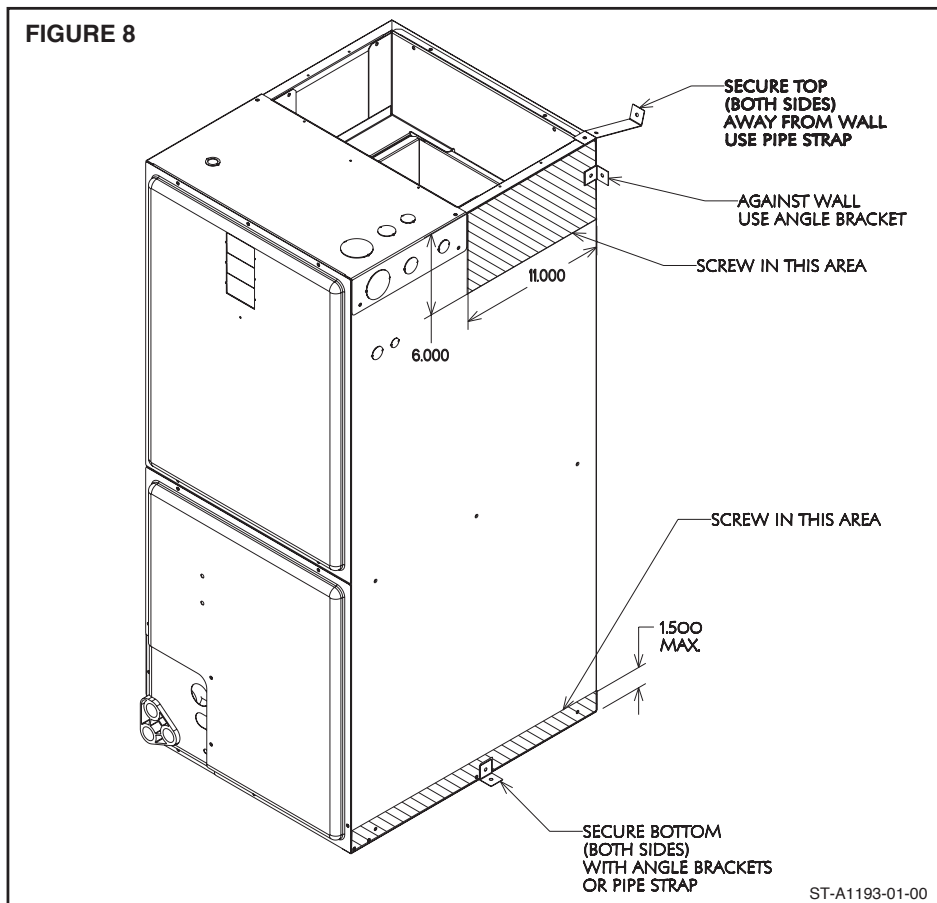

### 3.2.5 INSTALLATION IN CORROSIVE ENVIRONMENTS

The metal parts of this unit may be subject to rust or deterioration if exposed to a corrosive environment which can shorten its life. In addition to exposure to the exterior of the cabinet, chemical contaminants inside the building that can be drawn into the unit from the return air grille and attack structural metal parts, electrical components and the indoor coil, causing premature failure of the unit. If the unit is to be installed in an area where contaminants are likely to be a problem, special attention should be given to isolate the unit and return grille from contaminants.

### 3.2.6 SUPPORTING AIR-HANDLER IN HORIZONTAL APPLICATIONS

The air-handler must be adequately supported underneath if it is installed in the horizontal position to prevent it from sagging in the middle which can cause issues removing and re-installing the access panels. Position the unit on adequate supports or on support angles or channels (See Figure 9) before connecting ductwork to the unit. If an auxiliary overflow pan is required (See Section 3.3), the overflow pan will need to be adequately supported with the air-handler being supported underneath within the auxiliary overflow pan by angles and/or channels.

## 3.3 AUXILIARY OVERFLOW PAN

In compliance with recognized codes, an auxiliary overflow pan must be installed under all equipment containing evaporator coils that are located in any area of a structure where damage to the building or building contents may occur as a result of an overflow of the coil drain pan or a stoppage in the primary condensate drain piping. See Section 6.3 of this manual for information regarding the recommended auxiliary horizontal overflow pan (model RXBM) for this air-handler.



**FIGURE 9**  
**SUSPENDED HORIZONTAL AIR-HANDLER.**

**NOTE:**  
 HORIZONTAL LEFT ORIENTATION  
 DEPICTED IN ILLUSTRATION.  
 HORIZONTAL RIGHT ORIENTATION  
 IS SIMILAR IN INSTALLATION.

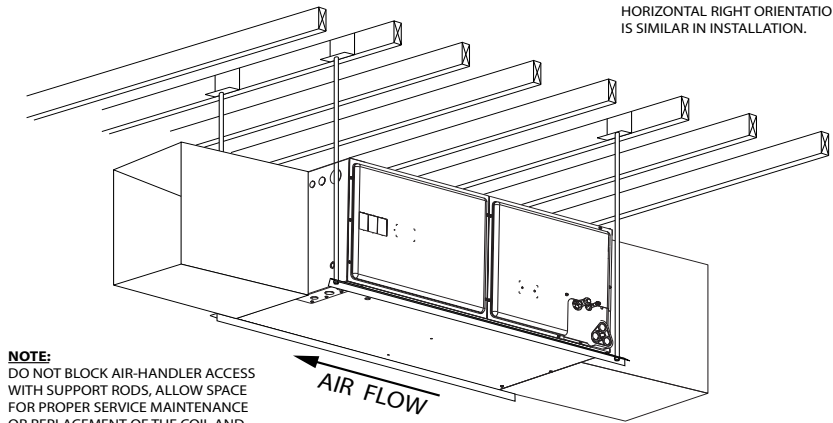

**NOTE:**  
 DO NOT BLOCK AIR-HANDLER ACCESS  
 WITH SUPPORT RODS, ALLOW SPACE  
 FOR PROPER SERVICE MAINTENANCE  
 OR REPLACEMENT OF THE COIL AND  
 BLOWER ASSEMBLY.

**SUPPORTING HORIZONTAL AIR-HANDLERS IN AUXILIARY  
 OVERFLOW PANS OR AIR-HANDLERS THAT ARE NOT SUSPENDED.**

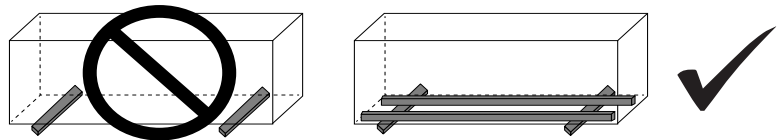

ST-A1298-01-00

### 3.4 CLEARANCES

- All units are designed for “0” inches clearance to combustible material on all cabinet surfaces except for downflow application with higher kW electric heat as noted below.
- Some units require a combustible floor base depending on the heating kW if installed in the downflow configuration on a combustible surface. The following table should be used to determine these requirements.

Model Cabinet Size	17	21	24
Maximum Model Designation kW	15	18	20

- Units with electric heating kW equal to or less than the values listed in the table do not require a combustible floor base. See Section 6.5 for Combustible Floor Base RXHB-XX.
- Units with electric heat require a one inch clearance to combustible material for the first three feet of supply plenum and ductwork.
- Vertical downflow applications require clearance on at least one side of the unit for electrical connections. Refrigerant and condensate drain connections are made on the front of the unit.
- All units require 24 inches minimum access to the front of the unit for service.
- These units may be installed in either ventilated or nonventilated spaces.

### 3.5 DUCT FLANGES

Duct flanges (4 pieces) are shipped with the unit and are to be field installed on the top of the air-handler using the following procedure and referring to Figure 10.

1. Loosen the screws attaching the heat barrier to the cabinet.
2. Form a 90° bend with the short leg length at approximately 9.9” from the end where the slot is cut in the flange to facilitate bending. The duct flanges are shipped sized for the 24.5” wide cabinet. For the 17.5” and 21” wide cabinets, cut the long leg as shown in Figure 10 to match the cabinet width.
3. Slide the duct flanges onto the screws loosened in step one above. Tighten the screws to secure the flanges.

**FIGURE 10**  
**DUCT FLANGE INSTALLATION**

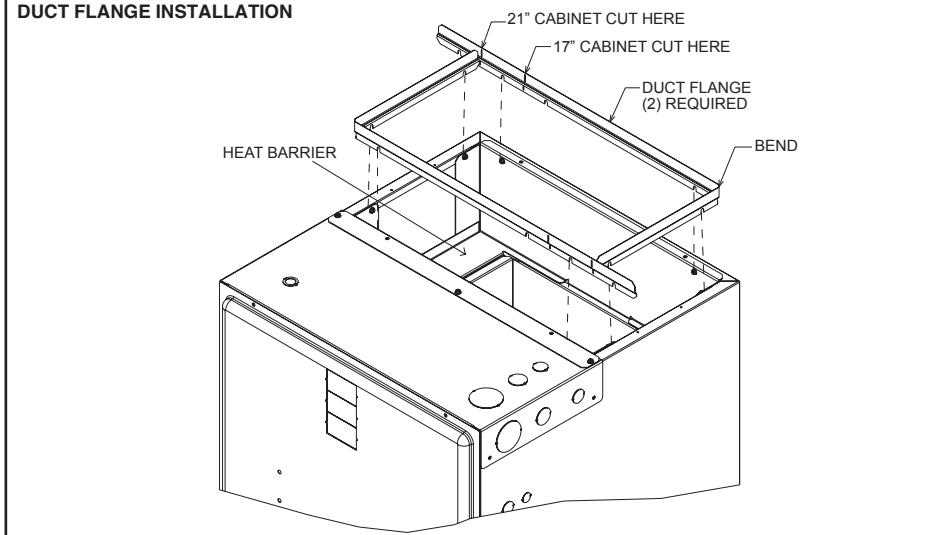

### 3.6 DUCTWORK

Field ductwork must comply with the National Fire Protection Association NFPA 90A, NFPA 90B and any applicable local ordinance.

#### **⚠ WARNING**

**Do not, under any circumstances, connect return ductwork to any other heat producing device such as fireplace insert, stove, etc. Unauthorized use of such devices may result in fire, carbon monoxide poisoning, explosion, personal injury or property damage.**

Sheet metal ductwork run in unconditioned spaces must be insulated and covered with a vapor barrier. Fibrous ductwork may be used if constructed and installed in accordance with SMACNA Construction Standard on Fibrous Glass Ducts. Ductwork must comply with National Fire Protection Association as tested by U/L Standard 181 for Class I Air Ducts. Check local codes for requirements on ductwork and insulation.

- Duct system must be designed within the range of external static pressure the unit is designed to operate against. It is important that the system airflow be adequate. Make sure supply and return ductwork, grilles, filters, accessories, etc. are accounted for in total resistance. Refer to the airflow performance tables in this manual to determine the available external static pressure for the particular air-handler model being installed.
- Design the duct system in accordance with “ACCA” Manual “D” Design for Residential Winter and Summer Air Conditioning and Equipment Selection. Latest editions are available from: “ACCA” Air Conditioning Contractors of America, 1513 16th Street, N.W., Washington, D.C. 20036. If duct system incorporates **flexible air duct**, be sure **pressure drop** information (straight length plus all turns) shown in “ACCA” Manual “D” is accounted for in system.
- Supply plenum is attached to the duct flanges supplied with the unit. See Section 3.5.
- **IMPORTANT:** If an elbow is included in the plenum close to the unit, it must not be smaller than the dimensions of the supply duct flange on the unit.
- **IMPORTANT:** The front flange on the return duct if connected to the blower casing must not be screwed into the area where the power wiring is located. Drills or sharp screw points can damage insulation on wires located inside unit.
- Secure the supply and return ductwork to the unit flanges, using proper fasteners for the type of duct used and tape or caulk the duct-to-unit joint as required to prevent air leaks.

### 3.7 RETURN AIR FILTER

An internal filter rack is not provided with this air-handler. Therefore, an external means of filtering the return air is required. External filters should be sized for a maximum of 300 feet/min air velocity or the maximum velocity recommended by the type of filter installed. One or more return air filter grilles, a filter rack attached to unit return air intake, or a filter rack installed between a sealed return air platform and the return duct are all acceptable means of filtration. All return ducts must be filtered, either at each return grille or at a common filter near the unit.

**Important:** Do not install a return air filter grille **and** a filter rack at the unit and do not install a filter in the supply duct system.

Filter type, sizing, and placement are critical to heating and cooling system performance. Reduced air-flow can shorten the life of system components such as the compressor, indoor coil, heater elements, over temperature limits, and relays. As filters near the end

of their useful life, the pressure drop through them increases. Therefore, it is important to factor the “end of life” (dirty) pressure drop of filters into the external static pressure of the duct system when selecting blower speeds and designing ductwork to assure the system is operating at the design CFM and system reliability is not compromised. Always verify that the system’s air-flow is within specifications by performing a temperature rise (heating mode) and/or temperature drop (cooling mode) with all filters in place.

**Important:** High efficiency pleated filters and electronic air cleaners typically have significantly higher pressure drop than standard efficiency fiberglass filters, especially when they get dirty. Do not use high efficiency filters or electronic air cleaners unless adequate filter area is provided to lower the filter pressure drop to an acceptable level.

## 3.8 REFRIGERANT LINE CONNECTIONS & CHARGING

### 3.8.1 PREPARATION

The coil is shipped with a low pressure (5-10 psig) charge of dry nitrogen which will be released when the rubber plugs are removed. Leave the rubber plugs in the refrigerant connection stubs on the air-handler until the refrigerant lines are ready to be brazed to the refrigerant connection stubs to prevent contaminants from entering the coil. Clean the ends of the tubing and coil connection stubs (inside and outside) with an alcohol wipe before inserting the line set tubes into the coil connection stubs to assure a quality leak-free braze joint.

Refer to the outdoor unit installation instructions for details on refrigerant line sizing and installation. Be sure to follow long line length guidelines if they apply.

Route the refrigerant tubing in a manner that does not block service access to the front of the air-handler.

### 3.8.2 LIQUID LINE FILTER DRIER

A new liquid filter drier must be installed every time any part of the system has been open to the atmosphere, even if it’s for a short period of time. The filter drier should be installed close to the air-handler for a system started up in the cooling mode and near the outdoor unit for a heat pump system started up in the heating mode. This allows the filter drier to catch any contaminants in the liquid line before they can enter the indoor or outdoor TXV inlet screen.

### 3.8.3 BRAZING

Air inside the tubing and coil should be displaced with dry nitrogen prior to the brazing process to prevent the formation of harmful copper oxide inside the tubing. It is very important not to pressurize the system with nitrogen while brazing or pin-hole leaks will form in the braze joint. This is accomplished by removing the gauge port valve core on one of the outdoor unit service valves to allow the pressure to be relieved as the heated nitrogen expands. Fill the system with dry nitrogen through the other service valve gauge port and then turn the nitrogen flow off just before brazing is begun.

Protect the TXV, copper to aluminum suction header joint, and outdoor unit service valves from overheating using a wet rag or heat sink compound. Leave the wet rag or heat sink material in place until the joint and surrounding tubing cools down to a safe temperature. Double tip torches can help minimize brazing time and heat conduction to the heat sensitive components if the flame is turned down and held on the joint just long enough to make the braze joint. With both single and double tip torches, turning the flame up too much and keeping the flame on the joint too long will damage the heat sensitive components even when a wet rag or heat sink compound is used.

Use a sheet metal shield to protect the cabinet’s paint from the torch flames during the brazing process. The vapor line insulation should be pushed back on the line about 12 inches from the joint and retained to prevent it from igniting or melting during the brazing process.

After the refrigerant brazed connections are made at the air-handler and the tubing has cooled down sufficiently, replace the coil section access panel if it has been removed and seal the air gap around the connection stubs with the foam rubber gasket included in the air-handler parts bag. Peel the self-adhesive backing off of the foam gasket and position it around the stubs with the adhesive side toward the cabinet, then press it firmly against the cabinet. The gasket is split to allow it to go over the stubs after the refrigerant tubes are brazed to the stubs. (See Figure 12 in Section 3.10)

After the foam gasket has been installed, the vapor line insulation should be pulled back in place so it contacts the air-handler cabinet to prevent condensate from forming on the cold tube and dripping off. A loosely fitting zip-tie placed around the insulation ½” from the end can be used to hold it in place so it doesn’t move away from the cabinet. For air-handlers with TXV’s, a section of the insulation will need to be cut out to make room for the externally mounted TXV bulb. (See Section 3.10) Once the bulb is mounted, insulate the bulb with the foam insulation included in the air-handler parts bag, making sure none of the vapor line is uninsulated.

### 3.8.4 LEAK TESTING

After all braze joints are completed, replace the valve core removed when purging with nitrogen and then leak test the system by pressurizing to 150 psig with dry nitrogen and allow the system to sit for at least 15 minutes (longer if possible) to assure the pressure does not drop.

### 3.8.5 EVACUATION

If no leaks are detected, evacuate the system down to 500 microns or below before charging the system or opening the service valves on the outdoor unit which will release the charge stored in the outdoor unit into the line set and air-handler coil. Failure to reach 500 microns of vacuum is a sign of a leak or excessive moisture inside the system.

### 3.8.6 REFRIGERANT CHARGING

Once the evacuation process is completed, break the vacuum with the refrigerant from a refrigerant cylinder or with refrigerant stored in the outdoor unit by opening the outdoor unit service valves. The charging process cannot be completed until the remaining steps in the installation process are completed and the indoor air-flow is adjusted to the proper level. See Section 4.7 for further details.

### 3.9 TXV SENSING BULB ATTACHMENT

**IMPORTANT:** DO NOT perform any brazing with the TXV bulb attached to the vapor line. After brazing operations have been completed and the tubing has cooled to the touch, clamp the TXV bulb securely on the vapor line at the 10 o'clock to 2 o'clock position (see Figures 11 and 12) with the strap provided in the parts bag. Insulate the TXV sensing bulb and suction line with the provided pressure sensitive insulation (size 4" x 7") and secure with provided wire ties.

**IMPORTANT:** TXV sensing bulb should be located on a horizontal section of suction line, just outside of coil box. The copper sensing bulb must never be placed on any aluminum tube as this will result in galvanic corrosion and eventual failure of the aluminum tube.

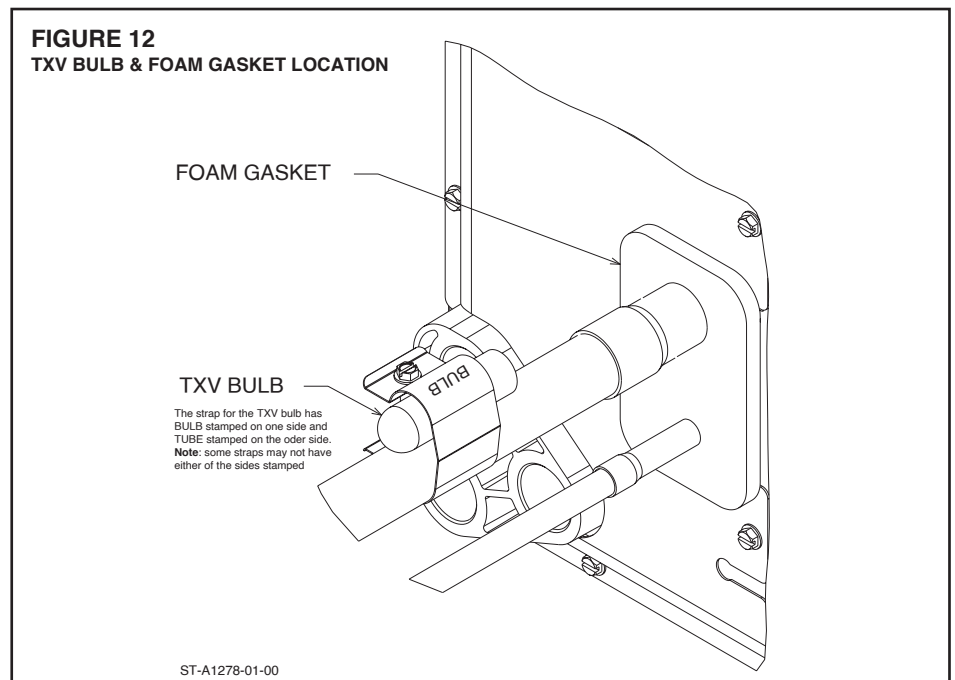
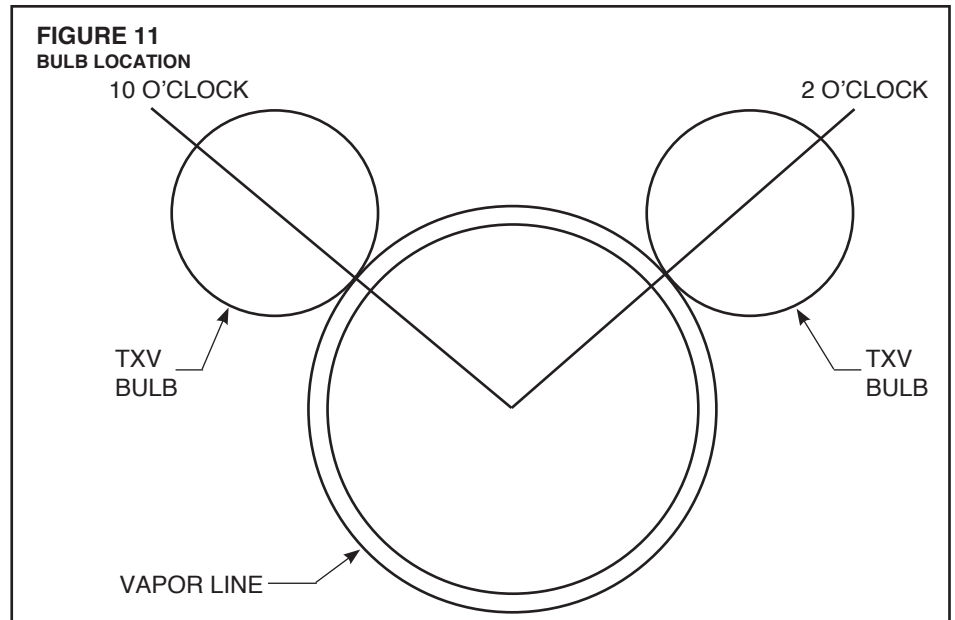

**FIGURE 13**  
**CONDENSATE DRAIN TRAP**

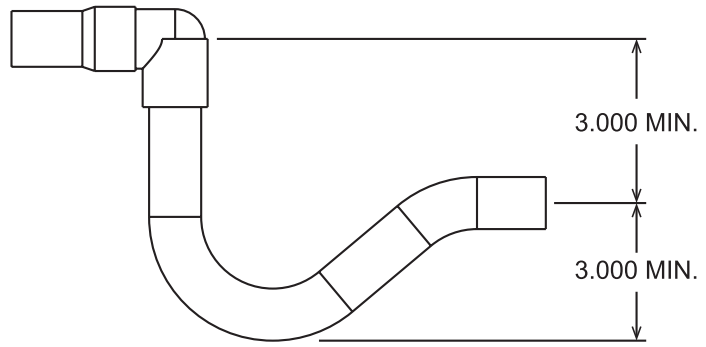

ST-A1244-01-00

### 3.10 CONDENSATE DRAIN

Consult local codes or ordinances for specific requirements.

**IMPORTANT:** When making drain fitting connections to the drain pan, use a thin layer of Teflon paste, silicone or Teflon tape and install hand tight.

**IMPORTANT:** When making drain fitting connections to drain pan, do not overtighten. Overtightening fittings can split pipe connections on the drain pan.

- Install drain lines so they do not block service access to front of the unit. Minimum clearance of 24 inches is required for filter, coil or blower removal and service access.
- Although the condensate drain pan is designed to be self draining, it is recommended that the air-handler cabinet be pitched slightly downward toward the primary drain connection to assure the condensate drains completely from the drain pan. The downward pitch should be approximately 1/8" per foot and in both axes.
- Do not reduce drain line size less than connection size provided on condensate drain pan.
- All drain lines must be pitched downward away from the unit a minimum of 1/8" per foot of line to ensure proper drainage.
- Do not connect condensate drain line to a closed or open sewer pipe. Run condensate to an open drain or outdoors.
- The drain line should be insulated where necessary to prevent sweating and damage due to condensate forming on the outside surface of the line.
- Make provisions for disconnecting and cleaning of the primary drain line should it become necessary. Install a 3 in. trap in the primary drain line as close to the unit as possible. Make sure that the top of the trap is below connection to the drain pan to allow complete drainage of pan (See Figure 13).
- The auxiliary drain line should be run to a place where it will be noticeable if it becomes operational. The building occupant should be warned that a problem exists if water should begin running from the auxiliary drain line. An auxiliary drain shut-off switch can be installed in lieu of an auxiliary drain line. The shut-off switch should be wired into the control circuit so the outdoor unit shuts down should the switch detect water.
- Plug the unused drain connection with the plugs provided in the parts bag, using a thin layer of teflon paste, silicone or teflon tape to form a water tight seal.
- Test the condensate drain pan and drain line after installation is complete. Pour water into drain pan, enough to fill drain trap and line. Check to make sure drain pan is draining completely, no leaks are found in drain line fittings, and water is draining from the open end of the primary drain line.

### 3.11 THERMOSTAT

See instructions for the condensing unit or heat pump for recommended room thermostats.

- On units with one electric heat sequencer (TD<sub>1</sub>) (see wiring diagram for electric heater), heat anticipator setting should be .16.
- On units with two electric heat sequencers (TD<sub>1</sub> & TD<sub>2</sub>) (see wiring diagram for electric heater), heat anticipator setting should be .32 if both are connected to same stage on thermostat. Setting should be .16 if (TD<sub>1</sub> & TD<sub>2</sub>) are connected to separate stages.

**NOTE:** Some thermostats contain a fixed, non-adjustable heat anticipator. Adjustment is not permitted.

- The thermostat should be mounted 4 to 5 feet above the floor on an inside wall of the living room or a hallway that has good air circulation from the other rooms being controlled by the thermostat. It is essential that there be free air circulation at the location of the same average temperature as other rooms being controlled.

Movement of air should not be obstructed by furniture, doors, draperies, etc. The thermostat should not be mounted where it will be affected by drafts, hot or cold water pipes or air ducts in walls, radiant heat from fireplace, lamps, the sun, T.V. or an outside wall. See instruction sheet packaged with thermostat for mounting and installation instructions.

## 3.12 ELECTRICAL WIRING

Field wiring must comply with the National Electric Code (C.E.C. in Canada) and any applicable local ordinance.

### 3.12.1 CONFIGURING UNIT FOR 208 VOLT POWER

The control transformer in 208/240V air-handlers must be configured in the field to operate on a 208 volt electrical supply to assure adequate control voltage (24+ volts) with the reduced supply voltage. The units are shipped from the factory for 220-240 volt applications. For 208 volt applications, disconnect electrical power to the unit and remove the blower access panel and then the control box cover located on the blower housing. Then remove the insulated cap from the 208 volt transformer terminal and move the BLACK wires that are connected to the 240 volt transformer terminal to the 208 volt transformer terminal. Plug the insulated cap onto the transformer 240V terminal.

The indoor blower motor in 208/240V versions of the (-)H1P air-handlers must also be configured for 208 volt applications to assure full air-flow delivery at the reduced voltage. This step is not required on (-)H2T or air-handlers since they have constant torque ECM motors. To configure the PSC motor in (-)H1P air-handlers for 208 volt applications, unplug the PURPLE motor lead connected to the insulated terminal on the end of the ORANGE wire coming from the transformer. Pull the cap out of the insulated terminal on end of the YELLOW motor lead and plug the cap into the terminal on the end of the PURPLE motor lead to eliminate the possibility of an electrical short. Plug the YELLOW motor lead into the terminal on the end of the ORANGE wire from the transformer. Secure the indoor blower motor wiring with zip ties to assure they can't come in contact with the blower wheel. Replace the control box cover and blower access panel.

### 3.12.2 GROUNDING

- This product must be sufficiently grounded in accordance with National Electrical Code (C.E.C. in Canada) and any applicable local ordinance.
- Grounding may be accomplished by grounding metal conduit when installed in accordance with electrical codes to the unit cabinet.

#### **WARNING**

**The unit must be permanently grounded. Failure to do so can result in electrical shock causing personal injury or death.**

- Grounding may also be accomplished by attaching ground wire(s) to ground lug(s) provided in the unit wiring compartment.
- Ground lug(s) are located close to wire entrance on left side of unit (upflow). Lug(s) may be moved to marked locations near wire entrance on right side of unit (upflow), if alternate location is more convenient.
- Use of multiple supply circuits require grounding of each circuit to lug(s) provided in unit.

### 3.12.3 POWER WIRING

It is important that proper electrical power is available for connection to the unit model being installed. See the unit nameplate, wiring diagram and electrical data in the installation instructions.

- If required, install a branch circuit disconnect of adequate size, located within sight of, and readily accessible to the unit.

**IMPORTANT:** Units with electric heater kits installed may be equipped with one, two, or three 30/60 amp circuit breakers. These breaker(s) protect the internal wiring in the event of a short circuit and serve as a disconnect. Circuit breakers installed within the unit do not provide over-current protection of the supply wiring and therefore may be sized larger than the branch circuit protection.

- Supply circuit power wiring must be 75°C minimum copper conductors only. See Electrical Data in Sections 3.12.5 and 3.12.6 for ampacity, wire size and circuit protector requirement. Supply circuit protective devices may be either fuses or "HACR" type circuit breakers.
- Field power wiring may be connected to either the right, left side or top. Three 7/8", 1<sup>3</sup>/<sub>32</sub>", 1<sup>31</sup>/<sub>32</sub>" dia. concentric knockouts are provided for connection of power wiring to unit.
- Field power wiring is to be connected to the power terminal block in unit control compartment.
- For units equipped with an electric heater kit, field power wiring is to be connected to the heater kit breaker, terminal block, or pullout disconnect terminals and the power wiring pigtail from the heater kit is to be connected to the unit power terminal block in the unit control compartment. Refer to installation instructions provided with the heater kit for additional details.

### 3.12.4 COPPER WIRE SIZE - AWG. (3% VOLTAGE DROP)

SUPPLY LENGTH	200 [61]	12	10	8	8	8	6	6	6	4	4	3	3	2	2	1	0	00
	150 [46]	12	10	10	10	8	8	6	6	6	4	4	3	3	2	1	0	00
	100 [30]	14	12	10	10	8	8	8	6	6	4	4	3	3	2	1	0	00
	50 [15]	14	12	10	10	8	8	8	6	6	4	4	3	3	2	1	0	00
		15	20	25	30	35	40	45	50	60	70	80	90	100	110	125	150	175
WIRE FEET	SUPPLY CIRCUIT AMPACITY																	
	NOTE: WIRE BASED ON COPPER CONDUCTORS 75°C MINIMUM RATING. FOR MORE THAN 3 CONDUCTORS IN A RACEWAY OR CABLE, SEE N.E.C. FOR DERATING THE AMPACITY OF EACH CONDUCTOR.																	

### 3.12.5.1 ELECTRICAL DATA – BLOWER MOTOR ONLY – WITHOUT ELECTRIC HEAT: (-)H1PZ

MODEL (-)H1P	VOLTAGE	PHASE*	HERTZ	HP	RPM	SPEEDS	CIRCUIT AMPS.	MINIMUM CIRCUIT AMPACITY	MAXIMUM CIRCUIT PROTECTOR
1817S	115	1	60	1/5	1075	2	2.3	3.0	15
2417S				1/5	1075	2	3.8	5.0	15
3017S				1/4	1075	2	4.7	6.0	15
3617S				1/3	1075	2	6.1	8.0	15
4221S				1/2	1075	2	7.9	10.0	15
4821S				3/4	1075	2	8.4	11.0	15
1817S	208/240	1 & 3	60	1/5	1075	2	1.7	3.0	15
2417S				1/5	1075	2	1.7	3.0	15
3017S				1/4	1075	2	2.5	4.0	15
3617S/3621S				1/3	1075	2	2.5	4.0	15
4221S				1/2	1075	2	5.2	7.0	15
4821ST/4824ST				3/4	1075	2	5.2	7.0	15
6024ST				3/4	1075	2	5.2	7.0	15

\*Blower motors are all single phase motors.

### 3.12.5.2 ELECTRICAL DATA – BLOWER MOTOR ONLY – WITHOUT ELECTRIC HEAT: (-)H2T

MODEL (-)H2T	VOLTAGE	PHASE*	HERTZ	HP [W]	RPM	SPEEDS	MOTOR AMPS.	MINIMUM CIRCUIT AMPACITY	MAXIMUM OVERCURRENT PROTECTION
2417S	115	1	60	1/3 [249]	300-1100	4	2.7	4	15
3617S/3621M				1/2 [373]	300-1100	4	3.4	5	15
4821S/4824S				3/4 [559]	300-1100	4	6.5	9	15
6021S/6024S				3/4 [559]	300-1100	4	8.0	10	15
2417S	208/240	1 & 3	60	1/3 [249]	300-1100	4	1.8	3	15
3617S/3621M				1/2 [373]	300-1100	4	2.4	3	15
4821S/4821M/4824S				3/4 [559]	300-1100	4	3.7	5	15
6021S				3/4 [559]	300-1100	4	5.6	7	15
6024S	208/230	1 & 3	60	3/4 [559]	300-1100	4	4.7	6	15

### 3.12.6.1 ELECTRICAL DATA – WITH ELECTRIC HEAT: (-)H1PZ

Installation of the UL Listed original equipment manufacturer provided heater kits listed in the following table is recommended for all auxiliary heating requirements.

AIR HANDLER MODEL (-)H1PZ	HEATER MODEL NO.	HEATER KW (208/240V)	PH/ HZ	NO. ELEMENTS - KW PER	TYPE SUPPLY CIRCUIT SINGLE CIRCUIT MULTIPLE CIRCUIT	HEATER AMPS	MOTOR AMPS	MINIMUM CIRCUIT AMPACITY	Maximum Overcurrent Protection
1817S 2417S (208/240V)	RXBH-17203J-1	2.25/3*0	1/60	1-3.0	SINGLE	10.8/125.	1.7	16/18	20/20
	RXBH-172403J-1	2.25/3.0	1/60	1-3.0	SINGLE	10.8/12.5	1.7	16/18	20/20
	RXBH-172405J-1	3.6/4.8	1/60	1-4.8	SINGLE	17.3/20.0	1.7	24/28	25/30
	RXBH-172407J-1	5.4/7.2	1/60	2-3.6	SINGLE	26.0/30.0	1.7	35/40	35/40
	RXBH-172410J-1	7.2/9.6	1/60	2-4.8	SINGLE	34.6/40.0	1.7	46/53	50/60
	RXBH-1724A13J-1	9.4/12.5	1/60	3-4.17	SINGLE	45.1/52.1	1.7	59/68	60/70
	RXBH-1724A13J-1	3.1/4.2	1/60	1-4.17	MULTIPLE CKT 1	15.0/17.4	1.7	21/24	25/25
		6.3/8.3	1/60	2-4.17	MULTIPLE CKT 2	30.1/34.7	0	38/44	40/45
	RXBH-1724A07C-1	5.4/7.2	3/60	3-2.4	SINGLE	15.0/17.3	1.7	21/24	25/25
	RXBH-1724A10C-1	7.2/9.6	3/60	3-3.2	SINGLE	20.0/23.1	1.7	28/31	30/35
RXBH-1724A13C-1	9.4/12.5	3/60	3-4.17	SINGLE	26.1/30.1	1.7	35/40	35/40	
3017S/3617S (208/240V)	RXBH-17203J-1	2.25/3.0	1/60	1-3.0	SINGLE	10.8/12.5	2.5	17/19	20/20
3017S 3617S 3621S (208/240V)	RXBH-172403J-1	2.25/3.0	1/60	1-3.0	SINGLE	10.8/12.5	2.5	17/19	20/20
	RXBH-172405J-1	3.6/4.8	1/60	1-4.8	SINGLE	17.3/20.0	2.5	25/29	25/30
	RXBH-172407J-1	5.4/7.2	1/60	2-3.6	SINGLE	26.0/30.0	2.5	36/41	40/45
	RXBH-172410J-1	7.2/9.6	1/60	2-4.8	SINGLE	34.6/40.0	2.5	47/54	50/60
	RXBH-1724A13J-1	9.4/12.5	1/60	3-4.17	SINGLE	45.1/52.1	2.5	60/69	60/70
	RXBH-1724A13J-1	3.1/4.2	1/60	1-4.17	MULTIPLE CKT 1	15.0/17.4	2.5	22/25	25/25
		6.3/8.3	1/60	2-4.17	MULTIPLE CKT 2	30.1/34.7	0	38/44	40/45
	RXBH-1724A15J-1	10.8/14.4	1/60	3-4.8	SINGLE	51.9/60.0	2.5	68/79	70/80
	RXBH-1724A15J-1	3.6/4.8	1/60	1-4.8	MULTIPLE CKT 1	17.3/20.0	2.5	25/29	25/30
		7.2/9.6	1/60	2-4.8	MULTIPLE CKT 2	34.6/40.0	0	44/50	45/50
	RXBH-1724A18J-1	12.8/17.0	1/60	3-5.68	SINGLE	61.6/70.8	2.5	81/92	90/100
	RXBH-1724A18J-1	4.3/5.7	1/60	1-5.68	MULTIPLE CKT 1	20.5/23.6	2.5	29/33	30/35
		8.5/11.3	1/60	2-5.68	MULTIPLE CKT 2	41.1/47.2	0	52/59	60/60
	RXBH-1724A07C-1	5.4/7.2	3/60	3-2.4	SINGLE	15.0/17.3	2.5	22/25	25/25
	RXBH-1724A10C-1	7.2/9.6	3/60	3-3.2	SINGLE	20.0/23.1	2.5	29/32	30/35
	RXBH-1724A13C-1	9.4/12.5	3/60	3-4.17	SINGLE	26.1/30.1	2.5	36/41	40/45
	RXBH-1724A15C-1	10.8/14.4	3/60	3-4.8	SINGLE	30.0/34.6	2.5	41/47	45/50
	RXBH-1724A18C-1	12.8/17.0	3/60	3-5.68	SINGLE	35.5/41.0	2.5	48/55	50/60

? Heater Kit Connection Type A=Breaker B=Terminal Block C=Pullout Disconnect



### 3.12.6.1 ELECTRICAL DATA – WITH ELECTRIC HEAT: (-)H1PZ - continued

AIR HANDLER MODEL (-)H1PZ	HEATER MODEL NO.	HEATER KW (208/240V)	PH/HZ	NO. ELEMENTS - KW PER	TYPE SUPPLY CIRCUIT SINGLE CIRCUIT MULTIPLE CIRCUIT	HEATER AMPS	MOTOR AMPS	MINIMUM CIRCUIT AMPACITY	MAXIMUM OVERCURRENT PROTECTION
4221S 4821S 4824S (208/240V)	RXBH-1724705J-1	3.6/4.8	1/60	1-4.8	SINGLE	17.3/20.0	5.2	29/32	30/35
	RXBH-1724707J-1	5.4/7.2	1/60	2-3.6	SINGLE	26.0/30.0	5.2	39/44	40/45
	RXBH-1724710J-1	7.2/9.6	1/60	2-4.8	SINGLE	34.6/40.0	5.2	50/57	50/60
	RXBH-1724A15J-1	10.8/14.4	1/60	3-4.8	SINGLE	51.9/60.0	5.2	72/82	80/90
	RXBH-1724A15J-1	3.6/4.8	1/61	1-4.8	MULTIPLE CKT 1	17.3/20.0	5.2	29/32	30/35
		7.2/9.6	1/60	2-4.8	MULTIPLE CKT 2	34.6/40.0	0.0	44/50	45/50
	RXBH-1724A18J-1	12/8/17	1/60	3-5.68	SINGLE	61.6/70.8	5.2	84/95	90/100
	RXBH-1724A18J-1	4.3/5.7	1/60	1-5.68	MULTIPLE CKT 1	20.5/23.6	5.2	33/36	35/40
		8.5/11.3	1/60	1-5.68	MULTIPLECKT2	41.1/47.2	0.0	52/59	60/60
	RXBH-24A20J-1	14.4/19.2	1/60	4-4.8	SINGLE	69.2/80	5.2	93/107	100/110
	RXBH-24A20J-1	7.2/9.5	1/60	2-4.8	MULTIPLE CKT 1	34.6/40.0	5.2	50/57	50/60
		7.2/9.6	1/60	2-4.8	MULTIPLE CKT 2	34.6/40.0	0.0	44/50	45/50
	RXBH-24A25J-1	18.0/24.0	1/60	6-4.0	SINGLE	86.4/99.9	5.2	115/132	125/150
	RXBH-24A25J-1 (4-ton only)	6.0/8.0	1/60	2-4.0	MULTIPLE CKT 1	28.8/33.3	5.2	43/49	45/50
		6.0/8.0	1/60	2-4.0	MULTIPLE CKT 2	28.8/33.3	0.0	36/42	40/45
		6.0/8.0	1/60	2-4.0	MULTIPLE CKT 3	28.8/33.3	0.0	36/42	40/45
	RXBH-1724A070-1	5.4/7.2	3/60	3-2.4	SINGLE	15.0/17.3	5.2	26/29	30/30
	RXBH-1724A10C-1	7.2/9.6	3/60	3-3.2	SINGLE	20.0/23.1	5.2	32/36	35/40
	RXBH-1724A15C-1	10.8/14.4	3/60	3-4.8	SINGLE	30.0/34.6	5.2	44/50	45/50
	RXBH-1724A180-1	12.8/17.0	3/60	3 - 5.68	SINGLE	35.6/41.0	5.2	51/58	60/60
	RXBH-24A20C-1	14.4/19.2	3/60	6-3.2	SINGLE	40.0/46.2	5.2	57/65	60/70
	RXBH-24A20C-1	7.2/9.6	3/60	3-3.2	MULTIPLE CKT 1	20.0/23.1	5.2	32/36	35/40
		7.2/9.6	3/60	3-3.2	MULTIPLE CKT 2	20.0/23.1	0.0	25/29	25/30
	RXBH-24A25C-1	18.0/24.0	3/60	6-4.0	SINGLE	50.0/57.8	5.2	69/79	70/80
	RXBH-24A25C-1 (4-ton only)	9.0/12.0	3/60	3-4.0	MULTIPLE CKT 1	25.0/28.9	5.2	38/43	40/45
		9.0/12.0	3/60	3-4.0	MULTIPLE CKT 2	25.0/28.9	0.0	32/37	35/40

? Heater Kit Connection Type A = Breaker B = Terminal Block C = Pullout Disconnect

### 3.12.6.1 ELECTRICAL DATA – WITH ELECTRIC HEAT: (-)H1PZ - continued

AIR HANDLER MODEL (-)H1PZ	HEATER MODEL NO.	HEATER KW (208/240V)	PH/HZ	NO. ELEMENTS - KW PER	TYPE SUPPLY CIRCUIT SINGLE CIRCUIT MULTIPLE CIRCUIT	HEATER AMPS	MOTOR AMPS	MINIMUM CIRCUIT AMPACITY	MAXIMUM OVERCURRENT PROTECTION
6024S (208/240V)	RXBH-1724?05J-1	3.6/4.8	1/60	1-4.8	SINGLE	17.3/20.0	5.2	29/32	30/35
	RXBH-1724?07J-1	5.4/7.2	1/60	2-3.6	SINGLE	26.0/30.0	5.2	39/44	40/45
	RXBH-1724?10J-1	7.2/9.6	1/60	2-4.8	SINGLE	34.6/40.0	5.2	50/57	50/60
	RXBH-1724A15J-1	10.8/14.4	1/60	3-4.8	SINGLE	51.9/60.0	5.2	72/82	80/90
	RXBH-1724A15J-1	3.6/4.8	1/60	1-4.8	MULTIPLE CKT1	17.3/20.0	5.2	29/32	30/35
		7.2/9.6	1/60	2-4.8	MULTIPLE CKT 2	34.6/40.0	0	44/50	45/50
	RXBH-1724A18J-1	12.8/17.0	1/60	3/5/68	SINGLE	61.6/70.8	5.2	84/95	90/100
	RXBH-1724A18J -1	4.3/5.7	1/60	1/5/68	MULTIPLE CKT 1	20.5/23.6	5.2	33/36	35/40
		8.5/11.3	1/60	2/5/68	MULTIPLECKT2	41.1/47.2	0	52/59	60/60
	RXBH-24A20J-1	14.4/19.2	1/60	4-4.8	SINGLE	69.2/80	5.2	93/107	100/110
	RXBH-24A20J-1	7.2/9.6	1/60	2-4.8	MULTIPLE CKT 1	34.6/40.0	5.2	50/57	50/60
		7.2/9.6	1/60	2-4.8	MULTIPLE CKT 2	34.6/40.0	0	44/50	45/50
	RXBH-24A25J-1	18.0/24.0	1/60	6-4.0	SINGLE	86.4/99.9	5.2	115/132	125/150
	RXBH-24A25J-1	6.0/8.0	1/60	2-4.0	MULTIPLE CKT 1	28.8/33.3	5.2	43/49	45/50
		6.0/8.0	1/60	2-4.0	MULTIPLE CKT 2	28.8/33.3	0	36/42	40/45
		6.0/8.0	1/60	2-4.0	MULTIPLE CKT 3	28.8/33.3	0	36/42	40/45
	RXBH-24A30J-1	21.6/28.8	1/60	6-4.8	SINGLE	103.8/120	5.2	137/157	150/175
	RXBH-24A30J-1	7.2/9.6	1/60	2-4.8	MULTIPLE CKT 1	34.6/40.0	5.2	50/57	50/60
		7.2/9.6	1/60	2-4.8	MULTIPLE CKT 2	34.6/40.0	0	44/50	45/50
		7.2/9.6	1/60	2-4.8	MULTIPLE CKT 3	34.6/40.0	0	44/50	45/50

? Heater Kit Connection Type A=Breaker B=Terminal Block C=Pullout Disconnect

Ⓛ D Voltage = 480 Volts.

\*Values only. No single point kit available.

**NOTES:**

- Electric heater BTUH - (heater watts + motor watts) × 3.412 (see airflow table for motor watts.)
- Supply circuit protective devices may be fuses or “HACR” type circuit breakers.
- Motor load is included in single circuit or circuit 1 of multiple circuits.
- Heater loads are balanced on 3 phase models with 3 or 6 heating elements only.
- Electric heater kits are not permitted for use with 115 volt air-handlers (A voltage).
- J Voltage (208/240V) single phase air-handlers are designed to be used with single or three phase 208/240V electric heaters. To connect 3 phase power to the air handler terminal block, bring only two leads to terminal block, cap, insulate, and fully secure the third lead.
- Do not install 480V electric heaters in 208/240V air-handlers.
- Do not install 208/240V electric heaters in 480V air-handlers.
- If the heater kit is listed under both single and multiple circuits, the heater kit is shipped from factory as multiple circuits. For single phase applications, Jumper bar kit RXBJ-A21 and RXBJ-A31 can be used to convert multiple circuits to a single supply circuit. See Section 6.2 for details.

### 3.12.6.2 ELECTRICAL DATA – WITH ELECTRIC HEAT: (-)H2T

Installation of the UL Listed original equipment manufacturer provided heater kits listed in the following table is recommended for all auxiliary heating requirements.

AIR HANDLER MODEL (-)H2TZ	HEATER MODEL NUMBER	HEATER KW (208/240V)	PH/HZ	NO. ELEMENTS - KW PER	TYPE SUPPLY CIRCUIT SINGLE CIRCUIT MULTIPLE CIRCUIT	HEATER AMPS	MOTOR AMPS	MINIMUM CIRCUIT AMPACITY	MAXIMUM OVERCURRENT PROTECTION
2417STANNJ	RXBH-17203J-1	2.25/3.0	1/60	1-3.0	SINGLE	10.8/12.5	1.8	16/18	20/20
	RXBH-1724203J-1	2.25/3.0	1/60	1-3.0	SINGLE	10.8/12.5	1.8	16/18	20/20
	RXBH-1724205J-1	3.6/4.8	1/60	1-4.8	SINGLE	17.3/20.0	1.8	24/28	30/30
	RXBH-1724207J-1	5.4/7.2	1/60	2-3.6	SINGLE	26.0/30.0	1.8	35/40	40/40
	RXBH-1724210J-1	7.2/9.6	1/60	2-4.8	SINGLE	34.6/40.0	1.8	46/53	50/60
	RXBH-1724A13J-1	9.4/12.5	1/60	3-4.17	SINGLE	45.1/52.1	1.8	59/68	60/70
	RXBH-1724A13J-1	3.1/4.2	1/60	1-4.17	MULTIPLE CKT 1	15.0/17.4	1.8	21/24	30/30
		6.3/8.3	1/60	2-4.17	MULTIPLE CKT 2	30.1/34.7	0.0	38/44	40/50
RXBH-1724A07C-1	5.4/7.2	3/60	3-2.4	SINGLE	15.0/17.3	1.8	21/24	30/30	
RXBH-1724A10C-1	7.2/9.6	3/60	3-3.2	SINGLE	20.0/23.1	1.8	28/32	30/40	
3617STANNJ	RXBH-17203J-1	2.25/3.0	1/60	1-3.0	SINGLE	10.8/12.5	2.4	17/19	20/20
	RXBH-1724203J-1	2.25/3.0	1/60	1-3.0	SINGLE	10.8/12.5	2.4	17/19	20/20
	RXBH-1724205J-1	3.6/4.8	1/60	1-4.8	SINGLE	17.3/20.0	2.4	25/28	30/30
	RXBH-1724207J-1	5.4/7.2	1/60	2-3.6	SINGLE	26.0/30.0	2.4	36/41	40/50
	RXBH-1724210J-1	7.2/9.6	1/60	2-4.8	SINGLE	34.6/40.0	2.4	47/54	50/60
	RXBH-1724A13J-1	9.4/12.5	1/60	3-4.17	SINGLE	45.1/52.1	2.4	60/69	60/70
	RXBH-1724A13J-1	3.1/4.2	1/60	1-4.17	MULTIPLE CKT 1	15.0/17.4	2.4	22/25	30/30
		6.3/8.3	1/60	2-4.17	MULTIPLE CKT 2	30.1/34.7	0.0	38/44	40/50
	RXBH-1724A15J-1	10.8/14.4	1/60	3-4.18	SINGLE	51.9/60.0	2.4	68/78	70/80
	RXBH-1724A15J-1	3.6/4.8	1/60	1-4.18	MULTIPLE CKT 1	17.3/20.0	2.4	25/28	30/30
		7.2/9.6	1/60	2-4.18	MULTIPLE CKT 2	34.6/40.0	0.0	44/50	50/50
	RXBH-1724A18J-1	12.8/17.0	1/60	4-4.26	SINGLE	61.6/70.8	2.4	80/92	90/100
	RXBH-1724A18J-1	4.3/5.7	1/60	1-5.68	MULTIPLE CKT 1	20.5/23.6	2.4	29/33	30/40
		8.5/11.3	1/60	2-5.68	MULTIPLE CKT 2	41.1/47.2	0.0	52/59	60/60
RXBH-1724A07C-1	5.4/7.2	3/60	3-2.4	SINGLE	15.0/17.3	2.4	22/25	30/30	
RXBH-1724A10C-1	7.2/9.6	3/60	3-3.2	SINGLE	20.0/23.1	2.4	28/32	30/40	
3621STANNJ 3621MTANNJ	RXBH-17203J-1	2.25/3.0	1/60	1-3.0	SINGLE	10.8/12.5	2.3	17/19	20/20
	RXBH-1724203J-1	2.25/3.0	1/60	1-3.0	SINGLE	10.8/12.5	2.3	17/19	20/20
	RXBH-1724205J-1	3.6/4.8	1/60	1-4.8	SINGLE	17.3/20.0	2.3	25/28	30/30
	RXBH-1724207J-1	5.4/7.2	1/60	2-3.6	SINGLE	26.0/30.0	2.3	36/41	40/50
	RXBH-1724210J-1	7.2/9.6	1/60	2-4.8	SINGLE	34.6/40.0	2.3	47/53	50/60
	RXBH-1724A13J-1	9.4/12.5	1/60	3-4.17	SINGLE	45.1/52.1	2.3	60/68	60/70
	RXBH-1724A13J-1	3.1/4.2	1/60	1-4.17	MULTIPLE CKT 1	15.0/17.4	2.3	22/25	30/30
		6.3/8.3	1/60	2-4.17	MULTIPLE CKT 2	30.1/34.7	0.0	38/44	40/50
	RXBH-1724A15J-1	10.8/14.4	1/60	3-4.18	SINGLE	51.9/60.0	2.3	68/78	70/80
	RXBH-1724A15J-1	3.6/4.8	1/60	1-4.18	MULTIPLE CKT 1	17.3/20.0	2.3	25/28	30/30
		7.2/9.6	1/60	2-4.18	MULTIPLE CKT 2	34.6/40.0	0.0	44/50	50/50
	RXBH-1724A18J-1	12.8/17.0	1/60	4-4.26	SINGLE	61.6/70.8	2.3	80/92	90/100
	RXBH-1724A18J-1	4.3/5.7	1/60	1-5.68	MULTIPLE CKT 1	20.5/23.6	2.3	29/33	30/40
		8.5/11.3	1/60	2-5.68	MULTIPLE CKT 2	41.1/47.2	0.0	52/59	60/60
RXBH-1724A07C-1	5.4/7.2	3/60	3-2.4	SINGLE	15.0/17.3	2.3	22/25	30/30	
RXBH-1724A10C-1	7.2/9.6	3/60	3-3.2	SINGLE	20.0/23.1	2.3	28/32	30/40	
3621MTANAJ	RXBH-17203J-1	2.25/3.0	1/60	1-3.0	SINGLE	10.8/12.5	2.4	17/19	20/20
	RXBH-1724203J-1	2.25/3.0	1/60	1-3.0	SINGLE	10.8/12.5	2.4	17/19	20/20
	RXBH-1724205J-1	3.6/4.8	1/60	1-4.8	SINGLE	17.3/20.0	2.4	25/28	30/30
	RXBH-1724207J-1	5.4/7.2	1/60	2-3.6	SINGLE	26.0/30.0	2.4	36/41	40/50
	RXBH-1724210J-1	7.2/9.6	1/60	2-4.8	SINGLE	34.6/40.0	2.4	47/54	50/60
	RXBH-1724A13J-1	9.4/12.5	1/60	3-4.17	SINGLE	45.1/52.1	2.4	60/69	60/70
	RXBH-1724A13J-1	3.1/4.2	1/60	1-4.17	MULTIPLE CKT 1	15.0/17.4	2.4	22/25	30/30
		6.3/8.3	1/60	2-4.17	MULTIPLE CKT 2	30.1/34.7	0.0	38/44	40/50
	RXBH-1724A15J-1	10.8/14.4	1/60	3-4.18	SINGLE	51.9/60.0	2.4	68/78	70/80
	RXBH-1724A15J-1	3.6/4.8	1/60	1-4.18	MULTIPLE CKT 1	17.3/20.0	2.4	25/28	30/30
		7.2/9.6	1/60	2-4.18	MULTIPLE CKT 2	34.6/40.0	0.0	44/50	50/50
	RXBH-1724A18J-1	12.8/17.0	1/60	4-4.26	SINGLE	61.6/70.8	2.4	80/92	90/100
	RXBH-1724A18J-1	4.3/5.7	1/60	1-5.68	MULTIPLE CKT 1	20.5/23.6	2.4	29/33	30/40
		8.5/11.3	1/60	2-5.68	MULTIPLE CKT 2	41.1/47.2	0.0	52/59	60/60
RXBH-1724A07C-1	5.4/7.2	3/60	3-2.4	SINGLE	15.0/17.3	2.4	22/25	30/30	
RXBH-1724A10C-1	7.2/9.6	3/60	3-3.2	SINGLE	20.0/23.1	2.4	28/32	30/40	

• ? Heater Kit Connection Type A=Breaker B=Terminal Block C=Pullout Disconnect

### 3.12.6.2 ELECTRICAL DATA – WITH ELECTRIC HEAT: (-)H2T - continued

AIR HANDLER MODEL (-)H2TZ	HEATER MODEL NUMBER	HEATER KW (208/240V)	PH/HZ	NO. ELEMENTS - KW PER	TYPE SUPPLY CIRCUIT SINGLE CIRCUIT MULTIPLE CIRCUIT	HEATER AMPS	MOTOR AMPS	MINIMUM CIRCUIT AMPACITY	MAXIMUM OVERCURRENT PROTECTION
4821STANNJ	RXBH-1724205J-1	3.6/4.8	1/60	1-4.8	SINGLE	17.3/20.0	3.7	27/30	30/30
	RXBH-1724207J-1	5.4/7.2	1/60	2-3.6	SINGLE	26.0/30.0	3.7	38/43	40/50
	RXBH-1724210J-1	7.2/9.6	1/60	2-4.8	SINGLE	34.6/40.0	3.7	48/55	50/60
	RXBH-1724A15J-1	10.8/14.4	1/60	3-4.18	SINGLE	51.9/60.0	3.7	70/80	70/80
	RXBH-1724A15J-1	3.6/4.8	1/60	1-4.18	MULTIPLE CKT 1	17.3/20.0	3.7	27/30	30/30
	RXBH-1724A15J-1	7.2/9.6	1/60	2-4.18	MULTIPLE CKT 2	34.6/40.0	0.0	44/50	50/50
	RXBH-1724A18J-1	12.8/17.0	1/60	4-4.26	SINGLE	61.6/70.8	3.7	82/94	90/100
	RXBH-1724A18J-1	4.3/5.7	1/60	1-5.68	MULTIPLE CKT 1	20.5/23.6	3.7	31/35	40/40
	RXBH-1724A18J-1	8.5/11.3	1/60	2-5.68	MULTIPLE CKT 2	41.1/47.2	0.0	52/59	60/60
	RXBH-24A20J-1	14.4/19.2	1/60	4-4.8	SINGLE	69.2/80	3.7	92/105	100/110
	RXBH-24A20J-1	7.2/9.6	1/60	2-4.8	MULTI CKT 1	34.6/40.0	3.7	48/55	50/60
	RXBH-24A20J-1	7.2/9.6	1/60	2-4.8	MULTI CKT 2	34.6/40.0	0.0	44/50	50/50
	RXBH-24A25J-1	18.0/24.0	1/60	6-4.0	SINGLE	86.4/99.9	3.7	113/130	120/150
	RXBH-24A25J-1	6.0/8.0	1/60	2-4.0	MULTI CKT 1	28.8/33.3	3.7	41/47	50/50
	RXBH-24A25J-1	6.0/8.0	1/60	2-4.0	MULTI CKT 2	28.8/33.3	0.0	36/42	40/50
	RXBH-24A25J-1	6.0/8.0	1/60	2-4.0	MULTI CKT 3	28.8/33.3	0.0	36/42	40/50
	RXBH-1724A07C-1	5.4/7.2	3/60	3-2.4	SINGLE	15.0/17.3	3.7	24/27	30/30
	RXBH-1724A10C-1	7.2/9.6	3/60	3-3.2	SINGLE	20.0/23.1	3.7	30/34	30/40
	RXBH-1724A15C-1	10.8/14.4	3/60	3-4.8	SINGLE	30.0/34.6	3.7	43/48	50/50
	RXBH-1724A18C-1	12.8/17.0	3/60	3-5.68	SINGLE	35.6/41.0	3.7	50/56	50/60
	RXBH-24A20C-1	14.4/19.2	3/60	6-3.2	SINGLE	40.0/46.2	3.7	55/63	60/70
	RXBH-24A20C-1	7.2/9.6	3/60	3-3.2	MULTIPLE CKT 1	20.0-23.1	3.7	30/34	30/35
	RXBH-24A20C-1	7.2/9.6	3/60	3-3.2	MULTIPLE CKT2	20.0/23.1	0.0	25/29	25/30
	RXBH-24A25C-1	18.0/24.0	3/60	6-4.0	SINGLE	50.0/57.8	3.7	68/77	70/80
RXBH-24A25C-1	9.0/12.0	3/60	3-4.0	MULTIPLE CKT 1	25.0/28.9	3.7	36/41	40/45	
RXBH-24A25C-1	9.0/12.0	3/60	3-4.0	MULTIPLE CKT2	25.0/28.9	0.0	32/37	35/40	
4821STANAJ	RXBH-1724205J-1	3.6/4.8	1/60	1-4.8	SINGLE	17.3/20.0	3.9	27/30	30/30
	RXBH-1724207J-1	5.4/7.2	1/60	2-3.6	SINGLE	26.0/30.0	3.9	38/43	40/50
	RXBH-1724210J-1	7.2/9.6	1/60	2-4.8	SINGLE	34.6/40.0	3.9	48/55	50/60
	RXBH-1724A15J-1	10.8/14.4	1/60	3-4.18	SINGLE	51.9/60.0	3.9	70/80	70/80
	RXBH-1724A15J-1	3.6/4.8	1/60	1-4.18	MULTIPLE CKT 1	17.3/20.0	3.9	27/30	30/30
	RXBH-1724A15J-1	7.2/9.6	1/60	2-4.18	MULTIPLE CKT 2	34.6/40.0	0.0	44/50	50/50
	RXBH-1724A18J-1	12.8/17.0	1/60	4-4.26	SINGLE	61.6/70.8	3.9	82/94	90/100
	RXBH-1724A18J-1	4.3/5.7	1/60	1-5.68	MULTIPLE CKT 1	20.5/23.6	3.9	31/35	40/40
	RXBH-1724A18J-1	8.5/11.3	1/60	2-5.68	MULTIPLE CKT 2	41.1/47.2	0.0	52/59	60/60
	RXBH-24A20J-1	14.4/19.2	1/60	4-4.8	SINGLE	69.2/80	3.9	92/105	100/110
	RXBH-24A20J-1	7.2/9.6	1/60	2-4.8	MULTI CKT 1	34.6/40.0	3.9	49/55	50/60
	RXBH-24A20J-1	7.2/9.6	1/60	2-4.8	MULTI CKT 2	34.6/40.0	0.0	44/50	50/50
	RXBH-24A25J-1	18.0/24.0	1/60	6-4.0	SINGLE	86.4/99.9	3.9	113/130	120/150
	RXBH-24A25J-1	6.0/8.0	1/60	2-4.0	MULTI CKT 1	28.8/33.3	3.9	41/48	50/50
	RXBH-24A25J-1	6.0/8.0	1/60	2-4.0	MULTI CKT 2	28.8/33.3	0.0	36/42	40/50
	RXBH-24A25J-1	6.0/8.0	1/60	2-4.0	MULTI CKT 3	28.8/33.3	0.0	36/42	40/50
	RXBH-1724A07C-1	5.4/7.2	3/60	3-2.4	SINGLE	15.0/17.3	3.9	24/27	30/30
	RXBH-1724A10C-1	7.2/9.6	3/60	3-3.2	SINGLE	20.0/23.1	3.9	30/34	30/40
	RXBH-1724A15C-1	10.8/14.4	3/60	3-4.8	SINGLE	30.0/34.6	3.9	43/49	50/50
	RXBH-1724A18C-1	12.8/17.0	3/60	3-5.68	SINGLE	35.6/41.0	3.9	50/57	50/60
	RXBH-24A20C-1	14.4/19.2	3/60	6-3.2	SINGLE	40.0/46.2	3.9	55/63	60/70
	RXBH-24A20C-1	7.2/9.6	3/60	3-3.2	MULTIPLE CKT 1	20.0-23.1	3.9	30/34	30/35
	RXBH-24A20C-1	7.2/9.6	3/60	3-3.2	MULTIPLE CKT2	20.0/23.1	0.0	25/30	25/30
	RXBH-24A25C-1	18.0/24.0	3/60	6-4.0	SINGLE	50.0/57.8	3.9	68/78	70/80
RXBH-24A25C-1	9.0/12.0	3/60	3-4.0	MULTIPLE CKT 1	25.0/28.9	3.9	37/41	40/45	
RXBH-24A25C-1	9.0/12.0	3/60	3-4.0	MULTIPLE CKT2	25.0/28.9	0.0	32/37	35/40	
4824STANNJ	RXBH-1724205J-1	3.6/4.8	1/60	1-4.8	SINGLE	17.3/20.0	3.2	26/29	30/30
	RXBH-1724207J-1	5.4/7.2	1/60	2-3.6	SINGLE	26.0/30.0	3.2	37/42	40/45
	RXBH-1724210J-1	7.2/9.6	1/60	2-4.8	SINGLE	34.6/40.0	3.2	48/54	50/60
	RXBH-1724A15J-1	10.8/14.4	1/60	3-4.18	SINGLE	51.9/60.0	3.2	69/79	70/80
	RXBH-1724A15J-1	3.6/4.8	1/60	1-4.18	MULTIPLE CKT 1	17.3/20.0	3.2	26/29	30/35
	RXBH-1724A15J-1	7.2/9.6	1/60	2-4.18	MULTIPLE CKT 2	34.6/40.0	0.0	44/50	50/50
	RXBH-1724A18J-1	12.8/17.0	1/60	4-4.26	SINGLE	61.6/70.8	3.2	81/93	90/100
	RXBH-1724A18J-1	4.3/5.7	1/60	1-5.68	MULTIPLE CKT 1	20.5/23.6	3.2	30/34	30/35
	RXBH-1724A18J-1	8.5/11.3	1/60	2-5.68	MULTIPLE CKT 2	41.1/47.2	0.0	52/59	60/60
	RXBH-24A20J-1	14.4/19.2	1/60	4-4.8	SINGLE	69.2/80.0	3.2	91/104	100/110
	RXBH-24A20J-1	7.2/9.6	1/60	2-4.8	MULTIPLE CKT 1	34.6/40.0	3.2	48/54	50/60
	RXBH-24A20J-1	7.2/9.6	1/60	2-4.8	MULTIPLE CKT 2	34.6/40.0	0.0	44/50	50/50
	RXBH-24A25J-1	18.0/24.0	1/60	6-4.0	SINGLE	86.4/99.9	3.2	112/129	120/130
	RXBH-24A25J-1	6.0/8.0	1/60	2-4.0	MULTIPLE CKT 1	28.8/33.3	3.2	42/48	50/50
	RXBH-24A25J-1	6.0/8.0	1/60	2-4.0	MULTIPLE CKT 2	28.8/33.3	0.0	36/42	40/50
	RXBH-24A25J-1	6.0/8.0	1/60	2-4.0	MULTIPLE CKT 3	28.8/33.3	0.0	36/42	40/50
	RXBH-24A30J-1	21.6/28.8	1/60	6-4.8	SINGLE	103.8/120.0	3.2	134/154	140/160
	RXBH-1724A07C-1	5.4/7.2	3/60	3-2.4	SINGLE	15.0/17.3	3.2	23/26	25/30
	RXBH-1724A10C-1	7.2/9.6	3/60	3-3.2	SINGLE	20.0/23.1	3.2	29/33	30/35
	RXBH-1724A15C-1	10.8/14.4	3/60	3-4.8	SINGLE	30.0/34.6	3.2	42/48	45/50
	RXBH-1724A18C-1	12.8/17.0	3/60	3-5.68	SINGLE	35.6/41.0	3.2	49/56	50/60
	RXBH-24A20C-1	14.4/19.2	3/60	6-3.2	SINGLE	40.0/46.2	3.2	54/62	60/70
	RXBH-24A20C-1	7.2/9.6	3/60	3-3.2	MULTIPLE CKT 1	20.0-23.1	3.2	29/33	30/35
	RXBH-24A20C-1	7.2/9.6	3/60	3-3.2	MULTIPLE CKT2	20.0/23.1	0.0	25/29	30/30
RXBH-24A25C-1	18.0/24.0	3/60	6-4.0	SINGLE	50.0/57.8	3.2	67/77	70/80	
RXBH-24A25C-1	9.0/12.0	3/60	3-4.0	MULTIPLE CKT 1	25.0/28.9	3.2	36/41	40/45	
RXBH-24A25C-1	9.0/12.0	3/60	3-4.0	MULTIPLE CKT2	25.0/28.9	0.0	32/37	40/40	

• ? Heater Kit Connection Type A=Breaker B=Terminal Block C=Pullout Disconnect

### 3.12.6.2 ELECTRICAL DATA – WITH ELECTRIC HEAT: (-)H2T - continued

AIR HANDLER MODEL (-)H2TZ	HEATER MODEL NUMBER	HEATER KW (208/240V)	PH/HZ	NO. ELEMENTS - KW PER	TYPE SUPPLY CIRCUIT SINGLE CIRCUIT MULTIPLE CIRCUIT	HEATER AMPS	MOTOR AMPS	MINIMUM CIRCUIT AMPACITY	MAXIMUM OVERCURRENT PROTECTION
6021STANAJ	RXBH-1724?05J-1	3.6/4.8	1/60	1-4.8	SINGLE	17.3/20.0	5.6	29/32	30/35
	RXBH-1724?07J-1	5.4/7.2	1/60	2-3.6	SINGLE	26.0/30.0	5.6	39/44	40/45
	RXBH-1724?10J-1	7.2/9.6	1/60	2-4.8	SINGLE	34.6/40.0	5.6	50/56	50/60
	RXBH-1724A15J-1	10.8/14.4	1/60	3-4.18	SINGLE	51.9/60.0	5.6	71/81	80/90
	RXBH-1724A15J-1	3.6/4.8	1/60	1-4.18	MULTIPLE CKT 1	17.3/20.0	5.6	28/31	30/35
		7.2/9.6	1/60	2-4.18	MULTIPLE CKT 2	34.6/40.0	0.0	50/56	50/60
	RXBH-1724A18J-1	12.8/17.0	1/60	4-4.26	SINGLE	61.6/70.8	5.6	83/95	90/100
	RXBH-1724A18J-1	4.3/5.7	1/60	1-5.68	MULTIPLE CKT 1	20.5/23.6	5.6	32/36	35/40
		8.5/11.3	1/60	2-5.68	MULTIPLE CKT 2	41.1/47.2	0.0	52/59	60/60
	RXBH-24A20J-1	14.4/19.2	1/60	4-4.8	SINGLE	69.2/80.0	5.6	93/106	100/110
	RXBH-24A20J-1	7.2/9.6	1/60	2-4.8	MULTIPLE CKT 1	34.6/40.0	5.6	50/56	50/60
		7.2/9.6	1/60	2-4.8	MULTIPLE CKT 2	34.6/40.0	0.0	44/50	50/50
	RXBH-24A25J-1	18.0/24.0	1/60	6-4.0	SINGLE	86.4/99.9	5.6	114/131	120/140
	RXBH-24A25J-1	6.0/8.0	1/60	2-4.0	MULTIPLE CKT 1	28.8/33.3	5.6	42/48	50/50
		6.0/8.0	1/60	2-4.0	MULTIPLE CKT 2	28.8/33.3	0.0	36/42	40/50
		6.0/8.0	1/60	2-4.0	MULTIPLE CKT 3	28.8/33.3	0.0	36/42	40/50
	RXBH-24A30J-1	21.6/28.8	1/60	6-4.8	SINGLE	103.8/120.0	5.6	135/156	140/160
	RXBH-24A30J-1	7.2/9.6	1/60	2-4.8	MULTIPLE CKT 1	34.6/40.0	5.6	50/56	50/60
		7.2/9.6	1/60	2-4.8	MULTIPLE CKT 2	34.6/40.0	0.0	44/50	50/50
		7.2/9.6	1/60	2-4.8	MULTIPLE CKT 3	34.6/40.0	0.0	44/50	50/50
	RXBH-1724A07C-1	5.4/7.2	3/60	3-2.4	SINGLE	15.0/17.3	5.6	25/28	30/30
	RXBH-1724A10C-1	7.2/9.6	3/60	3-3.2	SINGLE	20.0/23.1	5.6	31/35	40/40
	RXBH-1724A15C-1	10.8/14.4	3/60	3-4.8	SINGLE	30.0/34.6	5.6	44/50	50/50
	RXBH-1724A18C-1	12.8/17.0	3/60	3-5.68	SINGLE	35.6/41.0	5.6	51/58	60/60
	RXBH-24A20C-1	14.4/19.2	3/60	6-3.2	SINGLE	40.0/46.2	5.6	56/64	60/70
	RXBH-24A20C-1	7.2/9.6	3/60	3-3.2	MULTIPLE CKT 1	20.0-23.1	5.6	31/35	40/40
		7.2/9.6	3/60	3-3.2	MULTIPLE CKT2	20.0/23.1	0.0	25/29	30/30
	RXBH-24A25C-1	18.0/24.0	3/60	6-4.0	SINGLE	50.0/57.8	5.6	69/79	70/80
	RXBH-24A25C-1	9.0/12.0	3/60	3-4.0	MULTIPLE CKT 1	25.0/28.9	5.6	38/42	40/50
		9.0/12.0	3/60	3-4.0	MULTIPLE CKT2	25.0/28.9	0.0	32/37	40/40
	RXBH-24A30C-1	21.6/28.8	3/60	6-4.8	SINGLE	60.0/69.4	5.6	81/93	90/100
	RXBH-24A30C-1	10.8/14.4	3/60	3-4.8	MULTIPLE CKT 1	30.0/34.7	5.6	44/50	50/50
10.8/14.4		3/60	3-4.8	MULTIPLE CKT 2	30.0/34.7	0.0	38/44	40/50	
6024STANNJ	RXBH-1724?05J-1	3.6/4.8	1/60	1-4.8	SINGLE	17.3/20.0	4.7	28/31	30/35
	RXBH-1724?07J-1	5.4/7.2	1/60	2-3.6	SINGLE	26.0/30.0	4.7	39/44	40/45
	RXBH-1724?10J-1	7.2/9.6	1/60	2-4.8	SINGLE	34.6/40.0	4.7	50/56	50/60
	RXBH-1724A15J-1	10.8/14.4	1/60	3-4.18	SINGLE	51.9/60.0	4.7	71/81	80/90
	RXBH-1724A15J-1	3.6/4.8	1/60	1-4.18	MULTIPLE CKT 1	17.3/20.0	4.7	28/31	30/35
		7.2/9.6	1/60	2-4.18	MULTIPLE CKT 2	34.6/40.0	0.0	50/56	50/60
	RXBH-1724A18J-1	12.8/17.0	1/60	4-4.26	SINGLE	61.6/70.8	4.7	83/95	90/100
	RXBH-1724A18J-1	4.3/5.7	1/60	1-5.68	MULTIPLE CKT 1	20.5/23.6	4.7	32/36	35/40
		8.5/11.3	1/60	2-5.68	MULTIPLE CKT 2	41.1/47.2	0.0	52/59	60/60
	RXBH-24A20J-1	14.4/19.2	1/60	4-4.8	SINGLE	69.2/80.0	4.7	93/106	100/110
	RXBH-24A20J-1	7.2/9.6	1/60	2-4.8	MULTIPLE CKT 1	34.6/40.0	4.7	50/56	50/60
		7.2/9.6	1/60	2-4.8	MULTIPLE CKT 2	34.6/40.0	0.0	44/50	50/50
	RXBH-24A25J-1	18.0/24.0	1/60	6-4.0	SINGLE	86.4/99.9	4.7	114/131	120/140
	RXBH-24A25J-1	6.0/8.0	1/60	2-4.0	MULTIPLE CKT 1	28.8/33.3	4.7	42/48	50/50
		6.0/8.0	1/60	2-4.0	MULTIPLE CKT 2	28.8/33.3	0.0	36/42	40/50
		6.0/8.0	1/60	2-4.0	MULTIPLE CKT 3	28.8/33.3	0.0	36/42	40/50
	RXBH-24A30J-1	21.6/28.8	1/60	6-4.8	SINGLE	103.8/120.0	4.7	135/156	140/160
	RXBH-24A30J-1	7.2/9.6	1/60	2-4.8	MULTIPLE CKT 1	34.6/40.0	4.7	50/56	50/60
		7.2/9.6	1/60	2-4.8	MULTIPLE CKT 2	34.6/40.0	0.0	44/50	50/50
		7.2/9.6	1/60	2-4.8	MULTIPLE CKT 3	34.6/40.0	0.0	44/50	50/50
	RXBH-1724A07C-1	5.4/7.2	3/60	3-2.4	SINGLE	15.0/17.3	4.7	25/28	30/30
	RXBH-1724A10C-1	7.2/9.6	3/60	3-3.2	SINGLE	20.0/23.1	4.7	31/35	40/40
	RXBH-1724A15C-1	10.8/14.4	3/60	3-4.8	SINGLE	30.0/34.6	4.7	44/50	50/50
	RXBH-1724A18C-1	12.8/17.0	3/60	3-5.68	SINGLE	35.6/41.0	4.7	51/58	60/60
	RXBH-24A20C-1	14.4/19.2	3/60	6-3.2	SINGLE	40.0/46.2	4.7	56/64	60/70
	RXBH-24A20C-1	7.2/9.6	3/60	3-3.2	MULTIPLE CKT 1	20.0-23.1	4.7	31/35	40/40
		7.2/9.6	3/60	3-3.2	MULTIPLE CKT2	20.0/23.1	0.0	25/29	30/30
	RXBH-24A25C-1	18.0/24.0	3/60	6-4.0	SINGLE	50.0/57.8	4.7	69/79	70/80
	RXBH-24A25C-1	9.0/12.0	3/60	3-4.0	MULTIPLE CKT 1	25.0/28.9	4.7	38/42	40/50
		9.0/12.0	3/60	3-4.0	MULTIPLE CKT2	25.0/28.9	0.0	32/37	40/40
	RXBH-24A30C-1	21.6/28.8	3/60	6-4.8	SINGLE	60.0/69.4	4.7	81/93	90/100
	RXBH-24A30C-1	10.8/14.4	3/60	3-4.8	MULTIPLE CKT 1	30.0/34.7	4.7	44/50	50/50
10.8/14.4		3/60	3-4.8	MULTIPLE CKT 2	30.0/34.7	0.0	38/44	40/50	

• ? Heater Kit Connection Type A=Breaker B=Terminal Block C=Pullout Disconnect

\*Values only. No single point kit available.

**NOTES:**

- Electric heater BTUH - (heater watts + motor watts) x 3.414 (see airflow table for motor watts.)
- Supply circuit protective devices may be fuses or "HACR" type circuit breakers.
- If non-standard fuse size is specified, use next size larger standard fuse size.
- Largest motor load is included in single circuit or circuit 1 of multiple circuits.
- Heater loads are balanced on 3 phase models with 3 or 6 heaters only.
- No electrical heating elements are permitted to be used with A Voltage (115V) air handler.
- J Voltage (208/240V) single phase air handler is designed to be used with single or three phase 208/240V electric heaters. In the case of connecting 3 phase power to air handler terminal block without the heater, bring only two leads to terminal block, cap, insulate and fully secure the third lead.
- Do not use 480V electrical heaters on 208/240V air handler.
- If the kit is listed under both single and multiple circuits, the kit is shipped from factory as multiple circuits. For single phase application, Jumper bar kit RXBJ-A21 and RXBJ-A31 can be used to convert multiple circuits to a single supply circuit. Refer to Accessory Section for details.

### 3.12.7 ELECTRIC HEATER KIT SUPPLEMENTAL INFORMATION

MFD: MO./YEAR 01/2006 AIR CONDITIONING DIVISION MADE IN THE U.S.A. FAIT DANS L'USA

MODEL/MODELE # SERIAL/EN SERIE # M0106 38751

VOLTS 208/240 PH/Hz 1/60 MOTOR HP./F.L.A. 1/2 4.1 MOTEUR PSC/F.L.A.

ATTENTION: MARK HEATER INSTALLED! L'APPAREIL DE CHAUFFAGE DE MARQUE A INSTALLER

HEATER MODEL/MODELE D'APPAREIL DE CHAUFFAGE	TYPE SUPPLY CIRCUIT/TYPES LE CIRCUIT DE PROVISION	VOLTAGE/TENSION	PHASE	KW	HEATER AMPS/AMPLIS D'APPAREIL DE CHAUFFAGE	MOTOR AMPS/LES AMPLIS MOTEURS	MAXIMUM OVERCURRENT PROTECTION/LA PROTECTION MAXIMUM DE OVERCURRENT	MINIMUM BRANCH CIRCUIT AMPACITY/AMPACITY MINIMUM DE CIRCUIT DE BRANCHE
NO HEAT				0.0		4.1	15	5.2
RXBH-24A05J	SINGLE	208/240	1/60	3.6/4.8	17.3/20.0	6.0	30/35	30/33
RXBH-24A07J	SINGLE	208/240	1/60	5.4/7.2	26.0/30.0	6.0	40/45	40/45
RXBH-24A10J	SINGLE	208/240	1/60	7.2/9.6	34.6/40.0	6.0	60/60	51/58
RXBH-24A15J	SINGLE	208/240	1/60	10.8/14.4	51.9/60.0	6.0	80/90	73/83
RXBH-24A15J	MULTI CKT 1	208/240	1/60	3.6/4.8	17.3/20.0	6.0	30/35	30/33
RXBH-24A15J	MULTI CKT 2	208/240	1/60	7.2/9.6	34.6/40.0	0.0	45/50	44/50
RXBH-24A18J	SINGLE	208/240	1/60	12.8/17.0	61.2/70.8	6.0	90/100	84/96
RXBH-24A18J	MULTI CKT 1	208/240	1/60	6.4/8.5	30.8/35.4	6.0	50/60	46/52
RXBH-24A18J	MULTI CKT 2	208/240	1/60	6.4/8.5	30.8/35.4	0.0	40/45	39/45
RXBH-24A20J	SINGLE	208/240	1/60	14.4/19.2	69.2/80.0	6.0	100/110	94/108
RXBH-24A20J	MULTI CKT 1	208/240	1/60	7.2/9.6	34.6/40.0	6.0	60/60	51/58
RXBH-24A20J	MULTI CKT 2	208/240	1/60	7.2/9.6	34.6/40.0	0.0	45/50	44/50
RXBH-24A07C	SINGLE	208/240	3/60	5.4/7.2	15.0/17.3	6.0	30/30	27/30
RXBH-24A10C	SINGLE	208/240	3/60	7.2/9.6	20.0/23.1	6.0	35/40	33/37
RXBH-24A15C	SINGLE	208/240	3/60	10.8/14.4	30.0/34.6	6.0	45/60	45/51
RXBH-24A18C	SINGLE	208/240	3/60	12.4/17.0	35.6/41.0	6.0	60/60	52/59
RXBH-24A18C	MULTI CKT 1	208/240	3/60	6.4/8.5	17.8/20.5	6.0	30/35	30/34
RXBH-24A18C	MULTI CKT 2	208/240	3/60	6.4/8.5	17.8/20.5	0.0	25/30	23/26
RXBH-24A20C	SINGLE	208/240	3/60	14.2/19.2	40.0/46.2	6.0	60/70	58/66
RXBH-24A20C	MULTI CKT 1	208/240	3/60	7.2/9.6	20.0/23.1	6.0	35/40	33/37
RXBH-24A20C	MULTI CKT 2	208/240	3/60	7.2/9.6	20.0/23.1	0.0	25/30	25/29

S = SINGLE CIRCUIT/CIRCUIT SIMPLE M = MULTIPLE CIRCUIT/CIRCUIT MULTIPLE

INDOOR BLOWER MOTOR LOAD INCLUDED IN CIRCUIT # 1 OR TOTAL SUPPLY WIRE MUST BE RATED AT 75°C MINIMUM COPPER CONDUCTORS ONLY. TEST EXTERNAL STATIC RANGE .1 TO .5 IN. W.C. (HEAT PUMP & ELECTRIC HEAT).

UNITS WITH ELECTRIC HEATERS: CLEARANCE TO COMBUSTIBLE MATERIAL TO BE 0 IN. TO UNIT CASING AND 0 IN. TO PLENUM AND DUCT FOR FIRST 36 IN. MODELS HAVE INTEGRAL CIRCUIT BREAKERS WHICH PROVIDE SUPPLEMENTARY OVERCURRENT PROTECTION AND SERVE AS A MAINTENANCE "DISCONNECT". SUPPLY CIRCUIT NOT TO EXCEED 120 VOLTS TO GROUND ON SINGLE PHASE UNITS. REPLACE LINE SIDE BREAKER COVER(S) AFTER MAKING WIRING CONNECTIONS TO BREAKER(S). IF BLOWER-CONTROL ASSEMBLY REQUIRES REMOVAL, SEE "WARNING HAZARDOUS VOLTAGE".

CHARGEMENT DU MOTEUR SOUFFLEUR INTERNE INCLUS DANS LE CIRCUIT # 1 OU CAPACITÉ DU CÂBLAGE D'ALIMENTATION TOTAL DOIT ÊTRE DE 75C DU MINIMUM DE CONDUCTEURS DE CUIVRE SEULEMENT. TESTER L'INTERVALLE STATIQUE EXTERNE : 1 À 5 PO W.C. (THERMOPOMPE ET CHAUFFAGE ÉLECTRIQUE)

UNITÉS AVEC CHAUFFAGES ÉLECTRIQUES : LE DÉGAGEMENT AUX MATIÈRES COMBUSTIBLES DOIT ÊTRE DE 0 po AU BOITIER DE L'UNITÉ ET DE 0 po AU PLÉNUM ET CONDUIT POUR LES 36 PREMIERS po. LES MODÈLES DISPOSENT DE DISJONCTEURS INTÉGRÉS QUI FOURNISSENT UNE PROTECTION SUPPLÉMENTAIRE DE SURINTENSITÉ DE COURANT ET SERVENT DE « SECTIONNEUR » D'ENTRETIEN. LE CIRCUIT D'ALIMENTATION NE DOIT PAS DÉPASSER 120 VOLTS JUSQU'AU SOL SUR DES UNITÉS MONOPHASÉES. REMPLACER LE(S) COUVERCLE(S) DU DISJONCTEUR DU CÔTÉ SECTEUR APRÈS AVOIR EFFECTUÉ LA CONNEXION DES CÂBLAGES AU(X) DISJONCTEUR(S). SI L'ASSEMBLAGE DE CONTRÔLE DU VENTILATEUR A BESOIN D'ÊTRE DÉASSEMBLÉ, CONSULTER "AVERTISSEMENT DE TENSION DANGEREUSE"

Contractor should "mark or check" the left column for the kit installed.

If a heater kit is listed both Single and Multi-circuit, the kit is shipped as a Multi-circuit and will require a single point kit.

These are the required maximum and minimum circuit breaker sizes for overcurrent protection and should not be confused with the size of the breakers installed in the heater kit.

Only listed kits can be applied

Heater Kit Supplemental Information: What allows the manufacturer to use standard Circuit Breakers up to 60 amps inside the air handler, when using an approved Heater Kit?

National Electric Code (Section 424-22b) and UL standards allow subdividing heating element circuits, of less than 48 amps, using breakers of not more than 60 amps. Additionally per NEC 424-3b, a rating not less than 125 percent of the load and NEC 424-22c, which describes the supplementary overcurrent protection required to be factory-installed within, or on the heater. The breakers in the heater kit are not, and have never been intended to protect power wiring leading to the air handler unit. The breakers in the heating kit are for short circuit protection and to provide a disconnect. All internal unit wiring, where the breakers apply, has been UL approved for short circuit protection.

Ampacity, (not breaker size), determines supply circuit wire size. The ampacity listed on the unit rating plate and the Maximum and Minimum circuit breaker size (noted above) or in the units specification sheet or installation instructions provides the information to properly select wire and circuit breaker/protector size. The National Electric Code (NEC) specifies that the supply or branch circuit must be protected at the source.

### 3.12.8 CONTROL WIRING

**IMPORTANT:** Class 2 low voltage control wire should not be run in conduit with power wiring and must be separated from power wiring, unless class 1 wire of proper voltage rating is used.

- Low voltage control wiring should be 18 Awg. color-coded. For lengths longer than 100 ft., 16 Awg. wire should be used.
- Low voltage control connections are made to low voltage pigtails extending from top of air handler (upflow position - see Figure 3). Connections for control wiring are made with wire nuts. Control wiring knockouts (5/8 and 7/8) are also provided on the right and left side of the unit for side connection.
- See Section 3.12.9 below for control wiring connections.
- Make sure, after installation, separation of control wiring and power wiring has been maintained.
- See Section 3.12.1 for how to reconfigure transformer for 208 volt applications.

### 3.12.9 THERMOSTAT & CONTROL WIRING CONNECTIONS

**NOTE:** These low voltage application diagrams are generic. Your indoor/outdoor units may not have all the characteristics shown or may not wire exactly as shown. Refer to the diagrams and information sent with your indoor/outdoor sections.

**WIRE COLOR CODE:**

BK - BLACK	G - GREEN	P - PINK	W - WHITE
BR - BROWN	GY - GRAY	PR - PURPLE	Y - YELLOW
GL - BLUE	O - ORANGE	R - RED	

**FIGURE 14: (-)H1P/(-)H2T**  
TYPICAL THERMOSTAT: SINGLE STAGE COOLING W / ELECTRIC HEAT

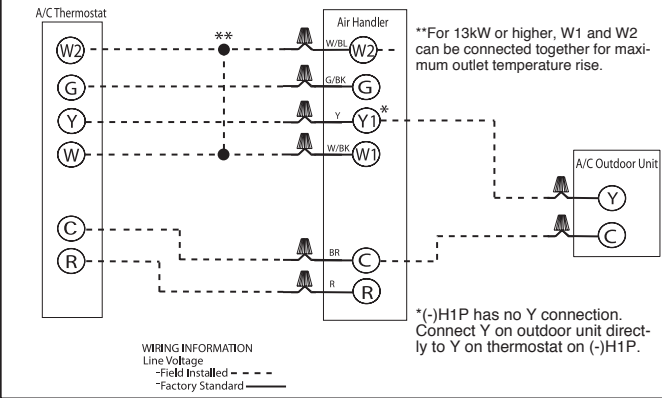

**FIGURE 15: (-)H1P/(-)H2T**  
TYPICAL THERMOSTAT: SINGLE STAGE HEAT PUMP W / ELECTRIC HEAT

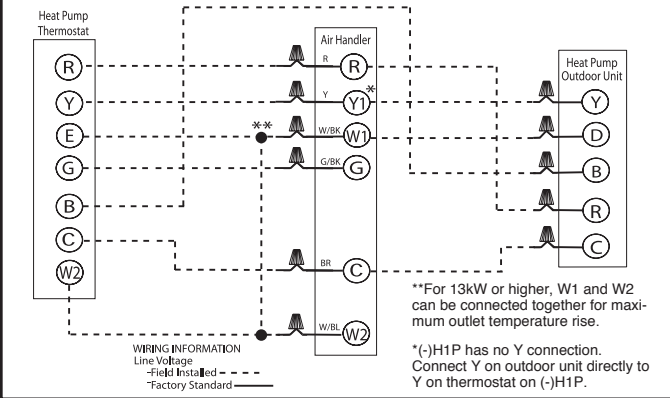

**FIGURE 16: (-)H2T**  
TYPICAL 2-STAGE THERMOSTAT: 2-STAGE COOLING WITH ELECTRIC HEAT

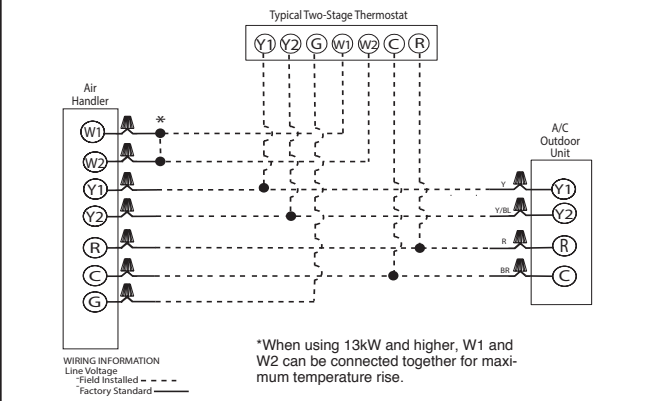

**FIGURE 17: (-)H2T**  
TYPICAL 2-STAGE THERMOSTAT: 2-STAGE HEAT PUMP WITH ELECTRIC BACK-UP HEAT

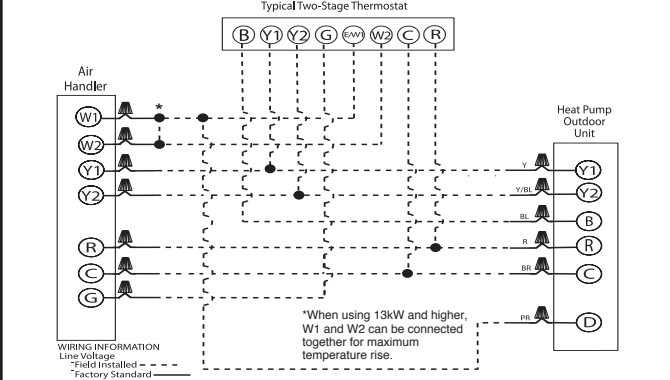

### 3.13 AIRFLOW

Airflow performance data is based on a dry indoor coil and no return air filter in place. Select performance table for appropriate unit size, voltage and number of electric heaters to be used. Make sure external static applied to unit allows operation within the minimum and maximum limits shown in Section 3.13.1 below for both cooling and electric heat operation. For optimum blower performance, operate the unit in the .3 to .7 in W.C. external static range. Units should be applied with a minimum of .1 in W.C. external static pressure.

**NOTE:** The air-flow performance data tables (see Section 3.13.3) list air-flow information for air-handlers without heater and with maximum heater kW allowed for each model. The following formula can be used to calculate the adjusted CFM for smaller kW heaters.

$$\text{Adjusted CFM} = \text{No Heat CFM} - [(\text{No Heat CFM} - \text{Max kW CFM}) \times \frac{\text{Actual kW}}{\text{Max kW}}]$$

### 3.13.1 GENERAL AIRFLOW OPERATING LIMITS

Cabinet Width	17		17/21		21			24	
Cooling BTUH x 1,000 Cooling Tons Nominal	18 1.5	24 2	30 2.5	36 3	42 3.5	48 4	60 5	48 4	60 5
Heat Pump or Air Conditioning Maximum Heat/Cool CFM [L/s] (37.5 CFM [18 L/s]/1,000 BTUH) (450 CFM [212 L/s]/Ton Nominal)	675 [319]	900 [425]	1125 [531]	1350 [637]	1575 [743]	1800 [850]	1925 [907]	1800 [850]	1930* [911]
Heat Pump or Air Conditioning Nominal Heat/Cool CFM [L/s] (33.3 CFM [16 L/s]/1,000 BTUH) (400 CFM [189 L/s]/Ton Nominal)	600 [283]	800 [378]	1000 [472]	1200 [566]	1400 [661]	1600 [755]	1750 [826]	1550 [732]	1800* [850]
Heat Pump or Air Conditioning Minimum Heat/Cool CFM [L/s] (30.0 CFM [14 L/s]/1,000 BTUH) (360 CFM [170 L/s]/Ton Nominal)	540 [255]	720 [340]	900 [425]	1080 [510]	1260 [595]	1440 [680]	1575 [743]	1440 [680]	1620* [765]
Maximum kW Electric Heating & Minimum Electric Heat CFM [L/s]	13 487 [230]	13 617 [291]	18 814 [384]	18 1054 [497]	20 1171 [553]	25 1502 [709]	25 1502 [709]	25 1502 [709]	1666 [786]
Maximum Electric Heat Rise °F [°C]	80 [26.7]	63 [17.2]	66 [18.9]	51 [10.6]	49 [9.4]	50 [10]	50 [10]	50 [10]	54 [12.2]

\*CFM [L/s] per ton requirements are reduced for 5 ton systems.

### 3.13.2 SELECTING INDOOR BLOWER MOTOR SPEED

The (-)H1P and (-)H2T air-handlers must be configured in the field to assure proper air-flow is delivered for the particular application it is being used in. Refer to the AIR-FLOW PERFORMANCE DATA in Section 3.13.3 to determine which speed tap is appropriate for the application.

**Important: The pressure drop through the required external filter is not included in the external static pressure shown in the Air-Flow Performance Tables in Section 3.13.3. The filter pressure drop must be added to the duct system pressure drop to determine total external static pressure. Filter pressure drop increases as the filter becomes dirty and must be considered when calculating worst case external static pressure.**

#### 3.13.2.1 (-)H1P MODELS (PSC MOTOR)

(-)H1P models are designed to be matched to a specific capacity outdoor unit, 1.5, 2.0, 2.5, 3.0, 3.5, 4.0, or 5.0 tons. They have PSC motors with 2 blower motor speed taps, low speed for applications with an external static pressure of up to 0.5" W.C. and high speed for applications with an external static pressure above 0.5" W.C. All models are shipped from the factory wired for high speed operation. **Note:** The external filter pressure drop must be included in the external static pressure when selecting a blower motor speed.

**115V & 208/240V Models:** The speed selection is made on the Blower Control Board. To change from high speed to low speed, remove the BLACK motor lead from the COM terminal, remove insulated cap from the end of the RED motor lead located in the control box and plug it into the terminal on the end of the BLACK motor lead to prevent it from shorting to ground. Attach RED wire to the COM terminal on the Blower Control Board.

#### 3.13.2.2 (-)H2T MODELS (CONSTANT TORQUE ECM MOTOR)

##### - 2 STAGE AIR-FLOW

(-)H2T models are specifically designed to be matched with 2-stage outdoor units, but can also be matched with single-stage outdoor units if properly configured for the correct indoor air-flow as covered in Section 3.13.2.3. They have constant torque ECM motors with 5 blower motor speed taps, labeled T1 through T5. Speed selections are made on the low voltage terminal block located on the motor housing. Speed tap T1 is always dedicated to continuous fan operation and delivers approximately 50% of the speed tap T4 air-flow. When matching a (-)H2T air-handler to a 2-stage outdoor unit, refer to the air-flow performance table in Section 3.13.3.3 to select the correct motor speed taps. The Yellow (Y1) and Blue (Y2) leads connected to the motor low voltage terminal block should be connected to terminals T2 and T3 on the motor low voltage terminal block for applications with low external static pressure (less than 0.5" W.C.) and terminals T4 and T5 for applications with high external static pressure (0.5" W.C. or more). The air-handler is configured from the factory for high external static pressure applications with the Yellow and Blue leads connected to terminals T4 and T5 on the motor low voltage terminal block. If the air-handler is being installed in an application with low external static pressure and speed taps T2 and T3 can deliver adequate air-flow according to the air-flow performance tables, then the Yellow and Blue leads should be moved to terminals T2 and T3 respectively on the motor low voltage terminal block on the motor low voltage terminal block to maximize efficiency, provide proper dehumidification, and to minimize air noise. The external filter pressure drop must be included in the external static pressure when selecting which motor speed taps to use.



### **3.13.2.3 (-)H2T MODELS (CONSTANT TORQUE ECM MOTOR) – SINGLE STAGE AIR-FLOW**

(-)H2T air-handlers may be matched to single stage outdoor units if properly configured. Each model can be matched with 2 different outdoor unit capacities, 1.5 - 2.0 tons, 2.5 - 3.0 tons, 3.5 - 4.0 tons, & 4.0 - 5.0 tons. It is recommended to connect the Yellow thermostat (Y1) pigtail to the thermostat cooling (Y) output and leave the Yellow/Blue (Y2) thermostat pigtail disconnected. Select the speed tap (2-5) that will deliver the desired air-flow at the application's total external static pressure (including external filter) from the air-flow performance table in Section 3.13.3.3 and connect the Yellow lead to the corresponding terminal on the motor low voltage terminal block. If terminal T5 is selected, the Blue lead will need to be moved from terminal T5 to another terminal. The Blue lead will never be energized if the Yellow/Blue thermostat pigtail is left disconnected.

### 3.13.3.1 240V AIRFLOW PERFORMANCE DATA: (-)H1P (PSC MOTOR)

Model Number (-)H1PZ	Motor Speed From Factory	Manufacturer Recommended Air Flow Range (Min / Max) CFM	Blower Size/ Motor HP [W] # of Speeds	Motor Speed	PSC CFM[Us] Air Delivery/RPMNvatts (Dry Coil — No Filter)							
					External Static Pressure-Inches W.C.							
					0.1 [.02]	0.2 [.05]	0.3 [.07]	0.4[.10]	0.5 1.121	0.6 [.15]	0.7 [.17]	
1817 No heater	High	517/711 CFM [244/336 Us]	10x6 1/5HP[149] 2 Speed	Low	CFM	668 [315]	637 [301]	595 [281]	560 [264]	517 [244]	—	—
					RPM	541	596	657	706	761	—	—
					Watts	180	171	166	161	155	—	—
				High	CFM	—	—	—	—	711 [336]	662 [312]	614 [290]
					RPM	—	—	—	—	812	853	890
					Watts	—	—	—	—	243	227	210
1817 with 13kw heater	High	487/661 CFM [230/312 Us]	10x6 1/5HP[149] 2 Speed	Low	CFM	638 [301]	607 [286]	565 [267]	530[250]	487 [230]	—	—
					RPM	571	656	687	736	791	—	—
					Watts	171	162	157	152	146	—	—
				High	CFM	—	—	—	—	661 [312]	612 [289]	564 [266]
					RPM	—	—	—	—	837	878	915
					Watts	—	—	—	—	232	216	199
2417 No heater	High	647/888 CFM [305/419 Us]	10x6 1/5HP[149] 2 Speed	Low	CFM	817 [386]	779 [368]	757 [357]	693 [327]	647 [305]	—	—
					RPM	616	667	715	770	808	—	—
					Watts	239	230	221	206	196	—	—
				High	CFM	—	—	—	—	888 [419]	828 [391]	774 [365]
					RPM	—	—	—	—	875	908	958
					Watts	—	—	—	—	331	313	301
2417 with 13kw heater	High	617/838 CFM [291/395 Us]	10x6 1/5HP[149] 2 Speed	Low	CFM	787 [371]	749 [353]	727 [343]	663 [313]	617 [291]	—	—
					RPM	646	697	745	800	838	—	—
					Watts	230	221	212	197	187	—	—
				High	CFM	—	—	—	—	838 [395]	778 [367]	724 [342]
					RPM	—	—	—	—	900	933	983
					Watts	—	—	—	—	320	302	290
3017 No heater	High	864/1004 CFM [408/474 Us]	10x8 1/4HP[186] 2 Speed	Low	CFM	1022 [482]	987 [466]	940 [444]	903 [426]	864 [408]	—	—
					RPM	700	754	794	833	870	—	—
					Watts	344	313	302	294	288	—	—
				High	CFM	—	—	—	—	1004 [474]	951 [449]	883 [417]
					RPM	—	—	—	—	924	953	975
					Watts	—	—	—	—	364	352	344
3017 with 18kw heater	High	814/904 CFM [384/427 Us]	10x8 1/4HP[186] 2 Speed	Low	CFM	972 [459]	937 [442]	890 [420]	853 [403]	814 [384]	—	—
					RPM	750	804	844	883	920	—	—
					Watts	324	293	282	274	268	—	—
				High	CFM	—	—	—	—	904 [427]	851 [402]	783 [370]
					RPM	—	—	—	—	949	978	1000
					Watts	—	—	—	—	334	322	314
3617/3621 No heater	High	1110/1248 CFM [524/589 Us]	10x8 1/3HP[249] 2 Speed	Low	CFM	1201 [567]	1170 [552]	1141 [538]	1104 [521]	1062[501]	—	—
					RPM	833	872	909	951	965	—	—
					Watts	462	427	406	396	385	—	—
				High	CFM	—	—	—	—	1194 [563]	1134 [535]	1078 [509]
					RPM	—	—	—	—	1024	1042	1060
					Watts	—	—	—	—	475	454	417

### 3.13.3.1 240V AIRFLOW PERFORMANCE DATA: (-)H1P (PSC MOTOR) - continued

Model Number (-)H1PZ	Motor Speed From Factory	Manufacturer Recommended Air Flow Range (Min / Max) CFM	Blower Size/ Motor HP [W] # of Speeds	Motor Speed	PSC CFM[Us] Air Delivery/RPM/Watts (Dry Coil — No Filter)							
					External Static Pressure-Inches W.C.							
						0.1 [02]	0.2 [05]	0.3 [07]	0.4[.10]	0.5 [.12]	0.6 [.15]	0.7 [17]
3617/3621 with 18kw heater	High	1060/1148 CFM [500/542 Us]	10x8 1/3HP[249] 2 Speed	Low	CFM	1151 [543]	1120 [529]	1091 [515]	1054 [497]	1012 [478]	—	—
					RPM	883	922	959	1001	1015	—	—
					Watts	442	407	386	376	365	—	—
				High	CFM	—	—	—	—	1094 [516]	1034 [488]	978 [462]
					RPM	—	—	—	—	1049	1067	1085
					Watts	—	—	—	—	445	424	386
4221 No heater	High	1241/1537 CFM [586/725 Us]	10x10 1/2HP[373] 2 Speed	Low	CFM	1493 [705]	1449 [684]	1363 [643]	1287 [607]	1211 [571]	—	—
					RPM	822	858	885	931	958	—	—
					Watts	540	519	506	484	459	—	—
				High	CFM	—	—	—	—	1514 [714]	1411 [666]	1315 [621]
					RPM	—	—	—	—	1061	1069	1078
					Watts	—	—	—	—	710	702	677
4221 with 20kw heater	High	1225/1500 CFM [553/678 Us]	10x10 1/2HPp73] 2 Speed	Low	CFM	1423 [672]	1379 [651]	1293 [610]	1217 [574]	1141 [538]	—	—
					RPM	870	882	925	957	992	—	—
					Watts	514	508	490	461	431	—	—
				High	CFM	—	—	—	—	1414 [667]	1311 [619]	1215 [573]
					RPM	—	—	—	—	1067	1080	1094
					Watts	—	—	—	—	700	678	665
4821/4824 No heater	High	1395/1824 CFM [658/861 Us]	10x10 3/4HP[559] 2 Speed	Low	CFM	1488[702]	1419 [670]	1466 [692]	1430 [675]	1395 [658]	—	—
					RPM	812	861	912	943	973	—	—
					Watts	554	545	526	508	491	—	—
				High	CFM	—	—	—	—	1824 [861]	1767 [834]	1653 [780]
					RPM	—	—	—	—	1102	1112	1121
					Watts	—	—	—	—	871	830	770
4821/4824 with 25kw heater	High	1225/1500 CFM [625/814 Us]	10x10 3/4HP[559] 2 Speed	Low	CFM	1418[669]	1349 [637]	1396 [659]	1360 [642]	1325 [625]	—	—
					RPM	862	899	935	965	995	—	—
					Watts	534	525	506	588	471	—	—
				High	CFM	—	—	—	—	1724 [814]	1667 [787]	1553 [733]
					RPM	—	—	—	—	1116	1119	1130
					Watts	—	—	—	—	810	780	730
6024 No heater	High	1710/1967 CFM [807/928 Us]	11x11 3/4HP[559] 2 Speed	Low	CFM	1866 [881]	1833 [865]	1806 [852]	1772 [836]	1710 [807]	—	—
					RPM	764	803	824	856	886	—	—
					Watts	514	756	733	715	701	—	—
				High	CFM	—	—	—	—	1967 [928]	1916 [904]	1863 [879]
					RPM	—	—	—	—	948	959	991
					Watts	—	—	—	—	850	827	816
6024 with 30kw heater	High	1640/1796 CFM [773/847 Us]	11x11 3/4HP[559] 2 Speed	Low	CFM	1796 [848]	1763 [832]	1736 [819]	1702 [803]	1640 [774]	—	—
					RPM	828	860	878	890	1001	—	—
					Watts	735	718	705	695	678	—	—
				High	CFM	—	—	—	—	1867 [881]	1816 [857]	1763 [832]
					RPM	—	—	—	—	989	1005	1020
					Watts	—	—	—	—	818	795	780

### 3.13.3.2 115/208V AIRFLOW PERFORMANCE DATA: (-)H1P (PSC MOTOR)

Model Number (-)H1PZ	Motor Speed From Factory	Manufacturer Recommended Air Flow Range (Min / Max) CFM	Blower Size/ Motor HP [W] # of Speeds	Motor Speed	PSC CFM[US] Air Delivery/RPM/Watts (Dry Coil — No Filter)							
					External Static Pressure-Inches W.C.							
						0.1 [.02]	0.2 [.05]	0.3 [.07]	0.4 [.10]	0.5 [.12]	0.6 [.15]	0.7 [.17]
1817ST No heater	High	517/711 CFM [244/336 Us]	10x6 1/5HP[149] 2 Speed	Low	CFM	668 [315]	637 [301]	595 [281]	560 [264]	517 [244]	—	—
					RPM	541	596	657	706	761	—	—
					Watts	180	171	166	161	155	—	—
				High	CFM	—	—	—	—	711 [336]	662 [312]	614 [290]
					RPM	—	—	—	—	812	853	890
					Watts	—	—	—	—	243	227	210
1817ST with 13kw heater	High	487/661 CFM [230/312 Us]	10x6 1/5HP[149] 2 Speed	Low	CFM	638 [301]	607 [286]	565 [267]	530 [250]	487 [230]	—	—
					RPM	571	656	687	736	791	—	—
					Watts	171	162	157	152	146	—	—
				High	CFM	—	—	—	—	661 [312]	612 [289]	564 [266]
					RPM	—	—	—	—	837	878	915
					Watts	—	—	—	—	232	216	199
24175T No heater	High	647/888 CFM [305/419 Us]	10x6 1/5HP[149] 2 Speed	Low	CFM	817 [386]	779 [368]	757 [357]	693 [327]	647 [305]	—	—
					RPM	616	667	715	770	808	—	—
					Watts	239	230	221	206	196	—	—
				High	CFM	—	—	—	—	888 [419]	828 [391]	774 [365]
					RPM	—	—	—	—	875	908	958
					Watts	—	—	—	—	331	313	301
2417ST with 13kw heater	High	617/838 CFM [291/395 Us]	10x6 1/5HP[149] 2 Speed	Low	CFM	787 [371]	749 [353]	727 [343]	663 [313]	617 [291]	—	—
					RPM	646	697	745	800	838	—	—
					Watts	230	221	212	197	187	—	—
				High	CFM	—	—	—	—	838 [395]	778 [367]	724 [342]
					RPM	—	—	—	—	900	933	983
					Watts	—	—	—	—	320	302	290
3017ST No heater	High	864/1004 CFM [408/474 Us]	10x8 1/4HP[186] 2 Speed	Low	CFM	1022 [482]	987 [466]	940 [444]	903 [426]	864 [408]	—	—
					RPM	700	754	794	833	870	—	—
					Watts	344	313	302	294	288	—	—
				High	CFM	—	—	—	—	1004 [474]	951 [449]	883 [417]
					RPM	—	—	—	—	924	953	975
					Watts	—	—	—	—	364	352	344
3017ST with 18kw heater	High	814/904 CFM [384/427 Us]	10x8 1/4HP[186] 2 Speed	Low	CFM	972 [459]	937 [442]	890 [420]	853 [403]	814 [384]	—	—
					RPM	750	804	844	883	920	—	—
					Watts	324	293	282	274	268	—	—
				High	CFM	—	—	—	—	904 [427]	851 [402]	783 [370]
					RPM	—	—	—	—	949	978	1000
					Watts	—	—	—	—	334	322	314
3617ST/3621ST No heater	High	1110/1248 CFM [524/589 Us]	10x8 1/3HP[249] 2 Speed	Low	CFM	1201 [567]	1170 [552]	1141 [538]	1104 [521]	1062 [501]	—	—
					RPM	833	872	909	951	965	—	—
					Watts	462	427	406	396	385	—	—
				High	CFM	—	—	—	—	1194 [563]	1134 [535]	1078 [509]
					RPM	—	—	—	—	1024	1042	1060
					Watts	—	—	—	—	475	454	417
3617ST/3621ST with 18kw heater	High	1060/1148 CFM [500/542 Us]	10x8 1/3HP[249] 2 Speed	Low	CFM	1151 [543]	1120 [529]	1091 [515]	1054 [497]	1012 [478]	—	—
					RPM	883	922	959	1001	1015	—	—
					Watts	442	407	386	376	365	—	—
				High	CFM	—	—	—	—	1094 [516]	1034 [488]	978 [462]
					RPM	—	—	—	—	1049	1067	1085
					Watts	—	—	—	—	445	424	386

### 3.13.3.2 115/208V AIRFLOW PERFORMANCE DATA: (-)H1P (PSC MOTOR) - continued

Model Number (-)H1PZ	Motor Speed From Factory	Manufacturer Recommended Air Flow Range (Min / Max) CFM	Blower Size/ Motor HP [W] # of Speeds	Motor Speed	PSC CFM[Us] Air Delivery/RPM/Watts (Dry Coil — No Filter)							
					External Static Pressure-Inches W.C.							
						0.1 [.02]	0.2 [.05]	0.3 [.07]	0.4 [.10]	0.5 [.12]	0.6 [.15]	0.7 [.17]
4221ST No heater	High	1241/1537 CFM [586/725 Us]	10x10 1/2HP[373] 2 Speed	Low	CFM	1493 [705]	1449 [684]	1363 [643]	1287 [607]	1211 [571]	—	—
					RPM	822	858	885	931	958	—	—
					Watts	540	519	506	484	459	—	—
				High	CFM	—	—	—	—	1514 [714]	1411 [666]	1315 [621]
					RPM	—	—	—	—	1061	1069	1078
					Watts	—	—	—	—	710	702	677
4221ST with 20kw heater	High	1225/1500 CFM [553/678 Us]	10x10 1/2HP[373] 2 Speed	Low	CFM	1423 [672]	1379 [651]	1293 [610]	1217 [574]	1141 [538]	—	—
					RPM	870	882	925	957	992	—	—
					Watts	514	508	490	461	431	—	—
				High	CFM	—	—	—	—	1414 [667]	1311 [619]	1215 [573]
					RPM	—	—	—	—	1067	1080	1094
					Watts	—	—	—	—	700	678	665
4821ST/4824ST No heater	High	1395/1824 CFM [658/861 Us]	10x10 3/4HP[559] 2 Speed	Low	CFM	1488 [702]	1477 [670]	1466 [692]	1430 [675]	1395 [658]	—	—
					RPM	812	861	912	943	973	—	—
					Watts	554	545	526	508	491	—	—
				High	CFM	—	—	—	—	1824 [861]	1767 [834]	1653 [780]
					RPM	—	—	—	—	1102	1112	1121
					Watts	—	—	—	—	871	830	770
4821ST/4824ST with 25kw heater	High	1225/1500 CFM [625/814 Us]	10x10 3/4HP[559] 2 Speed	Low	CFM	1418 [669]	1349 [637]	1396 [659]	1360 [642]	1325 [625]	—	—
					RPM	862	899	935	965	995	—	—
					Watts	534	525	506	588	471	—	—
				High	CFM	—	—	—	—	1724 [814]	1667 [787]	1553 [733]
					RPM	—	—	—	—	1116	1119	1130
					Watts	—	—	—	—	810	780	730
6024ST No heater	High	1710/1967 CFM [807/928 Us]	11x11 3/4HP[559] 2 Speed	Low	CFM	1866 [881]	1833 [865]	1806 [852]	1772 [836]	1710 [807]	—	—
					RPM	764	803	824	856	886	—	—
					Watts	514	756	733	715	701	—	—
				High	CFM	—	—	—	—	1967 [928]	1916 [904]	1863 [879]
					RPM	—	—	—	—	948	959	991
					Watts	—	—	—	—	850	827	816
6024ST with 30kw heater	High	1640/1796 CFM [773/847 Us]	11x11 3/4HP[559] 2 Speed	Low	CFM	1796 [848]	1763 [832]	1736 [819]	1702 [803]	1640 [774]	—	—
					RPM	828	860	878	890	1001	—	—
					Watts	735	718	705	695	678	—	—
				High	CFM	—	—	—	—	1867 [881]	1816 [857]	1763 [832]
					RPM	—	—	—	—	989	1005	1020
					Watts	—	—	—	—	818	795	780

### 3.13.3.3 115/208/240V AIRFLOW PERFORMANCE DATA: (CONSTANT TORQUE MOTOR)

Model No.	Tonnage Application	Motor Speed From Factory	Blower Size/ Motor HP [W] # of Speed	Motor Speed	CFM/RPM/WATTS - Dry Coil-No Filter										
					External Static Pressure Inches of W.C.										
					0.1	0.2	0.3	0.4	0.5	0.6	0.7	0.8	0.9	1	
2417ST No Heater	1.5 Ton	5	10x8 1/3 HP [373] 5 Speed	2	CFM	835	664	501	434	362	294	-	-	-	-
					RPM	570	581	617	687	746	814	-	-	-	-
					Watts	89	70	59	66	72	78	-	-	-	-
				3	CFM	-	-	-	-	649	589	545	489	441	383
					RPM	-	-	-	-	791	851	899	951	990	1049
					Watts	-	-	-	-	121	129	136	144	149	159
2417ST with 18 kW Heater	1.5 Ton	5	10x8 1/3 HP [373] 5 Speed	2	CFM	810	644	486	421	352	285	-	-	-	-
					RPM	599	610	648	721	783	854	-	-	-	-
					Watts	96	77	65	71	78	85	-	-	-	-
				3	CFM	-	-	-	-	629	572	528	474	428	372
					RPM	-	-	-	-	830	894	944	998	1040	1101
					Watts	-	-	-	-	132	141	148	157	163	174
2417ST No Heater	2 Ton	5	10x8 1/3 HP [373] 5 Speed	4	CFM	829	662	555	482	430	363	-	-	-	-
					RPM	573	584	635	705	757	814	-	-	-	-
					Watts	88	70	68	75	80	86	-	-	-	-
				5	CFM	-	-	-	-	799	759	722	670	628	583
					RPM	-	-	-	-	830	875	920	975	1016	1057
					Watts	-	-	-	-	164	172	181	190	199	206
2417ST with 18 kW Heater	2 Ton	5	10x8 1/3 HP [373] 5 Speed	4	CFM	805	642	538	467	417	352	-	-	-	-
					RPM	602	613	666	741	795	855	-	-	-	-
					Watts	96	76	74	82	87	94	-	-	-	-
				5	CFM	-	-	-	-	775	736	701	650	609	566
					RPM	-	-	-	-	871	919	966	1024	1066	1110
					Watts	-	-	-	-	178	187	197	207	217	225
3617ST No Heater	2.5 Ton	5	10x10 1/2 HP [373] 5 Speed	2	CFM	857	721	665	594	539	473	-	-	-	-
					RPM	586	596	648	712	768	827	-	-	-	-
					Watts	91	77	83	91	106	114	-	-	-	-
				3	CFM	-	-	-	-	943	902	859	814	771	723
					RPM	-	-	-	-	859	899	920	955	995	1030
					Watts	-	-	-	-	204	212	221	230	240	249
3617ST with 18 kW Heater	2.5 Ton	5	10x10 1/2 HP [373] 5 Speed	2	CFM	831	700	645	576	523	459	-	-	-	-
					RPM	615	625	680	748	807	869	-	-	-	-
					Watts	99	84	90	99	116	124	-	-	-	-
				3	CFM	-	-	-	-	914	875	833	790	748	701
					RPM	-	-	-	-	902	944	966	1003	1045	1082
					Watts	-	-	-	-	222	231	241	251	261	271
3617ST No Heater	3 Ton	5	10x10 1/2 HP [373] 5 Speed	4	CFM	855	762	705	655	597	536	-	-	-	-
					RPM	588	617	662	716	777	831	-	-	-	-
					Watts	103	87	93	100	116	115	-	-	-	-
				5	CFM	-	-	-	-	1094	1056	1016	974	937	901
					RPM	-	-	-	-	895	927	953	991	1021	1050
					Watts	-	-	-	-	270	280	287	299	308	317
3617ST with 18 kW Heater	3 Ton	5	10x10 1/2 HP [373] 5 Speed	4	CFM	829	739	683	635	579	520	-	-	-	-
					RPM	618	647	696	752	816	872	-	-	-	-
					Watts	112	95	101	109	126	125	-	-	-	-
				5	CFM	-	-	-	-	1061	1024	986	945	909	874
					RPM	-	-	-	-	940	973	1001	1040	1072	1102
					Watts	-	-	-	-	294	305	313	326	336	345

**3.13.3.3 115/208/240V AIRFLOW PERFORMANCE DATA: (CONSTANT TORQUE MOTOR) - continued**

Model No.	Tonnage Application	Motor Speed From Factory	Blower Size/ Motor HP [W] # of Speed	Motor Speed	CFM/RPM/WATTS - Dry Coil-No Filter										
					External Static Pressure Inches of W.C.										
					0.1	0.2	0.3	0.4	0.5	0.6	0.7	0.8	0.9	1	
3621ST No Heater	2.5 Ton	5	10x10 1/2 HP [373] 5 Speed	2	CFM	987	793	662	611	549	489	-	-	-	-
					RPM	591	598	640	700	755	817	-	-	-	-
					Watts	97	74	66	75	80	89	-	-	-	-
				3	CFM	-	-	-	-	941	898	852	809	755	712
					RPM	-	-	-	-	821	864	910	955	1006	1042
					Watts	-	-	-	-	171	179	188	196	207	216
3621ST with 18 kW Heater	2.5 Ton	5	10x10 1/2 HP [373] 5 Speed	2	CFM	957	763	632	581	519	459	-	-	-	-
					RPM	616	623	665	725	780	842	-	-	-	-
					Watts	92	69	61	70	75	84	-	-	-	-
				3	CFM	-	-	-	-	911	868	822	779	725	682
					RPM	-	-	-	-	846	889	935	980	1031	1067
					Watts	-	-	-	-	166	174	183	191	202	211
3621ST No Heater	3 Ton	5	10x10 1/2 HP [373] 5 Speed	4	CFM	983	808	706	654	580	529	-	-	-	-
					RPM	595	600	623	641	695	770	-	-	-	-
					Watts	96	75	72	79	87	92	-	-	-	-
				5	CFM	-	-	-	-	1099	1058	1017	975	937	905
					RPM	-	-	-	-	859	895	939	983	1020	1054
					Watts	-	-	-	-	223	231	241	251	263	276
3621ST with 18 kW Heater	3 Ton	5	10x10 1/2 HP [373] 5 Speed	4	CFM	953	778	676	624	550	499	-	-	-	-
					RPM	620	625	648	666	720	795	-	-	-	-
					Watts	91	70	67	74	82	87	-	-	-	-
				5	CFM	-	-	-	-	1069	1028	987	945	907	875
					RPM	-	-	-	-	884	920	964	1008	1045	1079
					Watts	-	-	-	-	218	226	236	246	258	271
4821ST****N No Heater	3.5 Ton	5	10x10 3/4 HP [373] 5 Speed	2	CFM	892	817	737	632	564	487	-	-	-	-
					RPM	611	660	718	817	864	910	-	-	-	-
					Watts	81	89	96	108	114	120	-	-	-	-
				3	CFM	-	-	-	-	1336	1290	1240	1198	1147	1085
					RPM	-	-	-	-	1006	1048	1084	1121	1170	1235
					Watts	-	-	-	-	341	356	367	379	396	421
4821ST****N with 20 kW Heater	3.5 Ton	5	10x10 3/4 HP [373] 5 Speed	2	CFM	892	817	737	632	564	487	-	-	-	-
					RPM	611	660	718	817	864	910	-	-	-	-
					Watts	81	89	96	108	114	120	-	-	-	-
				3	CFM	-	-	-	-	1336	1290	1240	1198	1147	1085
					RPM	-	-	-	-	1006	1048	1084	1121	1170	1235
					Watts	-	-	-	-	341	356	367	379	396	421
4821ST****N No Heater	4 Ton	5	10x10 3/4 HP [373] 5 Speed	4	CFM	1106	1032	973	901	819	712	-	-	-	-
					RPM	698	727	770	821	893	972	-	-	-	-
					Watts	129	134	142	150	163	178	-	-	-	-
				5	CFM	-	-	-	-	1472	1430	1392	1349	1308	1272
					RPM	-	-	-	-	1068	1104	1134	1171	1205	1243
					Watts	-	-	-	-	430	445	457	473	487	504

**3.13.3.3 115/208/240V AIRFLOW PERFORMANCE DATA: (CONSTANT TORQUE MOTOR) - continued**

Model No.	Tonnage Application	Motor Speed From Factory	Blower Size/ Motor HP [W] # of Speed	Motor Speed	CFM/RPM/WATTS - Dry Coil-No Filter										
					External Static Pressure Inches of W.C.										
					0.1	0.2	0.3	0.4	0.5	0.6	0.7	0.8	0.9	1	
4821ST***N with 25 kW Heater	4 Ton	5	10x10 3/4 HP [373] 5 Speed	4	CFM	1106	1032	973	901	819	712	-	-	-	-
					RPM	698	727	770	821	893	972	-	-	-	-
					Watts	129	134	142	150	163	178	-	-	-	-
				5	CFM	-	-	-	-	1472	1430	1392	1349	1308	1272
					RPM	-	-	-	-	1068	1104	1134	1171	1205	1243
					Watts	-	-	-	-	430	445	457	473	487	504
4824ST No Heater	3.5 Ton	5	10x10 3/4 HP [373] 5 Speed	2	CFM	964	882	809	676	581	464	-	-	-	-
					RPM	445	501	552	610	651	698	-	-	-	-
					Watts	79	88	96	104	111	113	-	-	-	-
				3	CFM	-	-	-	-	1372	1312	1257	1201	1126	1035
					RPM	-	-	-	-	765	803	837	875	910	948
					Watts	-	-	-	-	292	305	317	330	342	354
4824ST with 20 kW Heater	3.5 Ton	5	10x10 3/4 HP [373] 5 Speed	2	CFM	934	852	779	646	551	434	-	-	-	-
					RPM	470	526	577	635	676	723	-	-	-	-
					Watts	74	83	91	99	106	108	-	-	-	-
				3	CFM	-	-	-	-	1342	1282	1227	1171	1096	1005
					RPM	-	-	-	-	790	828	862	900	935	973
					Watts	-	-	-	-	287	300	312	325	337	349
4824ST No Heater	4 Ton	5	10x10 3/4 HP [373] 5 Speed	4	CFM	1152	1080	1004	926	837	734	-	-	-	-
					RPM	493	539	587	636	687	726	-	-	-	-
					Watts	113	122	131	141	151	159	-	-	-	-
				5	CFM	-	-	-	-	1507	1459	1412	1360	1308	1241
					RPM	-	-	-	-	798	833	861	894	922	960
					Watts	-	-	-	-	350	364	378	389	400	415
4824ST with 20 kW Heater	4 Ton	5	10x10 3/4 HP [373] 5 Speed	4	CFM	1122	1050	974	896	807	704	-	-	-	-
					RPM	518	564	612	661	712	751	-	-	-	-
					Watts	108	117	126	136	146	154	-	-	-	-
				5	CFM	-	-	-	-	1477	1429	1382	1330	1278	1211
					RPM	-	-	-	-	823	858	886	919	947	985
					Watts	-	-	-	-	345	359	373	384	395	410
6024ST No Heater	4.5 Ton	5	11x11 3/4 HP [373] 5 Speed	2	CFM	1321	1127	914	512	398	321	-	-	-	-
					RPM	567	573	579	588	629	667	-	-	-	-
					Watts	164	138	115	78	81	86	-	-	-	-
				3	CFM	-	-	-	-	1511	1467	1414	1356	1301	1243
					RPM	-	-	-	-	822	850	879	906	937	968
					Watts	-	-	-	-	375	386	397	405	418	431
6024ST with 25 kW Heater	4.5 Ton	5	11x11 3/4 HP [373] 5 Speed	2	CFM	1281	1093	886	497	386	311	-	-	-	-
					RPM	595	602	608	618	660	700	-	-	-	-
					Watts	179	150	126	85	88	93	-	-	-	-
				3	CFM	-	-	-	-	1466	1423	1372	1315	1262	1205
					RPM	-	-	-	-	864	893	923	951	984	1016
					Watts	-	-	-	-	408	420	432	442	456	470



**3.13.3.3 115/208/240V AIRFLOW PERFORMANCE DATA: (CONSTANT TORQUE MOTOR) - continued**

Model No.	Tonnage Application	Motor Speed From Factory	Blower Size/ Motor HP [W] # of Speed	Motor Speed	CFM/RPM/WATTS - Dry Coil-No Filter										
					External Static Pressure Inches of W.C.										
					0.1	0.2	0.3	0.4	0.5	0.6	0.7	0.8	0.9	1	
6024ST No Heater	5 Ton	5	11x11 3/4 HP [373] 5 Speed	4	CFM	1367	1193	1097	1032	957	869	-	-	-	-
					RPM	583	588	622	661	700	746	-	-	-	-
					Watts	176	154	156	165	174	184	-	-	-	-
				5	CFM	-	-	-	-	1877	1837	1797	1754	1707	1673
					RPM	-	-	-	-	924	946	967	995	1018	1045
					Watts	-	-	-	-	602	614	628	643	656	673
6024ST with 30 kW Heater	5 Ton	5	11x11 3/4 HP [373] 5 Speed	4	CFM	1326	1157	1064	1001	928	843	-	-	-	-
					RPM	612	618	653	694	735	783	-	-	-	-
					Watts	192	167	170	180	190	200	-	-	-	-
				5	CFM	-	-	-	-	1821	1781	1743	1701	1656	1623
					RPM	-	-	-	-	970	994	1016	1045	1069	1097
					Watts	-	-	-	-	656	670	684	701	714	734
6021ST No Heater	4.5 Ton	5	11x11 3/4 HP [373] 5 Speed	2	CFM	1120	1061	997	875	819	777	-	-	-	-
					RPM	657	710	773	859	892	917	-	-	-	-
					Watts	133	143	154	170	176	180	-	-	-	-
				3	CFM	-	-	-	-	1515	1464	1416	1363	1295	1248
					RPM	-	-	-	-	1047	1089	1134	1175	1228	1259
					Watts	-	-	-	-	439	454	471	486	507	519
6021ST with 25 kW Heater	4.5 Ton	5	11x11 3/4 HP [373] 5 Speed	2	CFM	1080	1021	957	835	779	737	-	-	-	-
					RPM	682	735	798	884	917	942	-	-	-	-
					Watts	128	138	149	165	171	175	-	-	-	-
				3	CFM	-	-	-	-	1475	1424	1376	1323	1255	1208
					RPM	-	-	-	-	1072	1114	1159	1200	1253	1284
					Watts	-	-	-	-	434	449	466	481	502	514
6021ST No Heater	5 Ton	5	11x11 3/4 HP [373] 5 Speed	4	CFM	1223	1171	1113	1057	967	892	-	-	-	-
					RPM	702	750	807	859	927	966	-	-	-	-
					Watts	167	178	190	201	216	224	-	-	-	-
				5	CFM	-	-	-	-	1896	1861	1829	1790	1730	1568
					RPM	-	-	-	-	1180	1210	1240	1277	1301	1302
					Watts	-	-	-	-	727	742	759	780	771	683
6021ST with 30 kW Heater	5 Ton	5	11x11 3/4 HP [373] 5 Speed	4	CFM	1183	1131	1073	1017	927	852	-	-	-	-
					RPM	727	775	832	884	952	991	-	-	-	-
					Watts	162	173	185	196	211	219	-	-	-	-
				5	CFM	-	-	-	-	1856	1821	1789	1750	1690	1528
					RPM	-	-	-	-	1205	1235	1265	1302	1326	1327
					Watts	-	-	-	-	722	737	754	775	766	678

# 4.0 START-UP

<b>PRE-START CHECKLIST</b>	
<input type="checkbox"/> YES <input type="checkbox"/> NO	Is unit properly located, level, secure and serviceable?
<input type="checkbox"/> YES <input type="checkbox"/> NO	Has auxiliary pan been provided under the unit with separate drain? (Units installed above a finished ceiling).
<input type="checkbox"/> YES <input type="checkbox"/> NO	Is condensate line properly sized, run, trapped, pitched and tested?
<input type="checkbox"/> YES <input type="checkbox"/> NO	Is ductwork correctly sized, run, taped and insulated?
<input type="checkbox"/> YES <input type="checkbox"/> NO	Have all cabinet openings and wiring been sealed with caulking?
<input type="checkbox"/> YES <input type="checkbox"/> NO	Is the filter clean, in place and of adequate size?
<input type="checkbox"/> YES <input type="checkbox"/> NO	Is the wiring tight, correct and to the wiring diagram?
<input type="checkbox"/> YES <input type="checkbox"/> NO	Is the unit properly grounded and protected (fused)?
<input type="checkbox"/> YES <input type="checkbox"/> NO	Is the thermostat heat anticipator been set properly?
<input type="checkbox"/> YES <input type="checkbox"/> NO	Is the unit circuit breaker(s) rotated properly "on" up - "off" down?
<input type="checkbox"/> YES <input type="checkbox"/> NO	Are the unit circuit breaker(s) line lug cover(s) in place?
<input type="checkbox"/> YES <input type="checkbox"/> NO	Are all access panels in place and secure?
Refer to outdoor unit installation instructions for system start-up instructions and refrigerant charging instructions.	

## 4.1 PRE-START CHECKLIST

## 4.2 SYSTEM START-UP AND OPERATIONAL CHECK-OUT

After the air-handler and other system components have been installed and the Pre-Start Checklist has been completed, the system should be started up and an operational check-out should be performed. The operational check-out includes checking sequence of operation of the controls, air-flow, and refrigerant charge. If the controls are not found to be functioning properly, or the air-flow or refrigerant charge are not within specifications, corrective action must be taken. The following sections are provided to assist the installer with the operational check-out.

## 4.3 SEQUENCE OF OPERATION

### 4.3.1 COOLING MODE

When the thermostat calls for cooling, the G terminal on the blower control board is energized which in turn energizes the indoor blower motor. This causes the indoor blower to circulate air through the air-handler and duct system during the cooling cycle. For (-)H2T air-handlers, when the Y1 (1st stage) thermostat pigtail is energized by the thermostat, the indoor blower motor operates at the 1st stage cooling air-flow level. When the Y2 (2nd stage) thermostat pigtail is energized by a 2-stage thermostat, the air-flow increases to the 2nd stage of cooling air-flow. As the 2-stage thermostat alternates between the 1st and 2nd cooling stages, the indoor air-flow alternates between the 1st and 2nd stages of air-flow.

When the thermostat call is satisfied or turned to the off position. The G and Y inputs from the thermostat are de-energized. A time delay programmed into the (-)H1P blower control board or (-)H2T motor keeps the blower motor energized for an additional 30 seconds to extract the residual cooling from the cold indoor coil before it shuts down. If the thermostat is set for continuous fan operation, the motor continues to operate when

the call for cooling ends. The air-flow on an (-)H2T air-handler will be reduced to the continuous fan speed while the air-flow on a (-)H1P air-handler will remain constant.

### **4.3.2 ELECTRIC HEAT MODE**

When the thermostat calls for the 1st stage of heat, the W1 terminal on the blower control board is energized. This energizes the indoor blower motor and all of the electric heater elements for heater kits with 10kW of heat or less and the 1st stage elements for 13kW heater kits and higher. If W1 and W2 thermostat pigtails at the air-handler are wired together on 13kW heater kits and higher, all of the elements to be energized. For 13kW heater kits and higher, a 2-stage heat thermostat can be used to energize the W2 terminal on the blower control board upon a call for a 2nd stage of heat which will in turn will energize the 2nd stage heater elements. The heater kit will cycle between the 1st and 2nd stages of heat at the direction of the thermostat.

When the thermostat call for heat is satisfied or the thermostat is turned to the off position, the W1 terminal on the blower control board is de-energized which will de-energize the heating elements in a few seconds as the bimetallic disc in the sequencer cools. The blower motor will be de-energized 75 seconds after the call for heat ends.

### **4.3.3 HEAT PUMP HEATING MODE**

When the heat pump thermostat is set to "heat" mode, the "B" terminal on the outdoor unit is energized which energizes the reversing valve and switches it to the heating position. When the thermostat calls for heat, the G terminal on the blower control board is energized which in turn energizes the indoor blower motor. This causes the indoor blower to circulate air through the air-handler and duct system during the heating cycle.

For (-)H2T air-handlers, when the Y1 (1st stage) thermostat pigtail is energized by the thermostat, the indoor blower motor operates at the 1st stage heating air-flow level. When the Y2 (2nd stage) thermostat pigtail is energized by a 2-stage thermostat, the air-flow increases to the 2nd stage of heating air-flow. The air-flow levels for both stages the heat pump heating are the same for the cooling mode. As the 2-stage thermostat alternates between the 1st and 2nd heat pump heating stages, the indoor air-flow alternates between the 1st and 2nd stages of air-flow.

Should the room temperature continue to fall when the system is operating in the heat pump heating mode, the thermostat energizes the W2 terminal on the blower control board which energizes the supplemental electric heat. For 13kW heater kits and larger, the W1 and W2 pigtails can be connected together for maximum supplemental heat for 2nd stage or wired to the W1 and W2 terminals on the thermostat separately to provide a 3rd stage of heat as needed.

When the thermostat call is satisfied. The G and Y terminals inputs from the thermostat are de-energized. A time delay programmed into the (-)H1P blower control board or (-)H2T motor keeps the blower motor energized for an additional 30 seconds to extract the residual heat from the warm indoor coil. If the thermostat is set for continuous fan operation, the motor continues to operate when the call for heating ends. The air-flow on an (-)H2T air-handler will be reduced to the continuous fan speed while the air-flow on a (-)H1P air-handler will remain constant.

### **4.3.4 SUPPLEMENTAL ELECTRIC HEAT DURING DEFROST**

Supplemental electric heat during the defrost cycle can be provided by running a wire from the purple pigtail wire (from D terminal on defrost control) on the outdoor heat pump unit to the W1 pigtail on the air-handler. This will energize the electric heat during the defrost cycle to prevent cold air from being discharged from the supply registers in the home.

For the most economical operation and if cold discharge air is not a concern, do not run the wire from the purple pigtail on the outdoor unit to the W1 pigtail on the air-handler. In this case, supplemental heat will only be energized if the thermostat energizes the 2nd stage of heat during the defrost cycle due to a significant drop in room temperature.

### **4.3.5 EMERGENCY HEAT (HEAT PUMP)**

If heat pump thermostat is set to the "Emergency Heat" mode, the outdoor unit will be prevented from operating and heat will be provided solely by the electric heater. The electric heater elements and indoor blower motor will be energized any time there is a call for heat with no compressor and outdoor fan operation. A jumper should be installed between the W1 and E terminals on the thermostat sub-base so a call for emergency heat will be transferred to the 1st stage of heat of the thermostat. The indoor blower will cycle on and off with the electric heater elements when the thermostat fan setting is set to the "auto" mode, although there will be a 75 second delay off period for the blower motor after the call for heat ends.

### **4.3.6 THERMOSTAT FAN SETTING**

If the thermostat "FAN" setting is adjusted to the "AUTO" position, the indoor blower motor will only operate when there is a call for cooling or heating. If the setting is adjusted to the "ON" position, the indoor blower motor will operate continuously. On (-)H2T models, the indoor blower motor will operate at a reduced speed when there is no call for cooling and heating to reduce power consumption and noise.

## 4.4 CORRECTING ELECTRIC HEAT KW FOR VOLTAGE

The actual electric heat kW varies with the supply voltage. Use the following formula to correct the heater rated kW at voltages other than rated voltage.

$$\text{Actual kW} = \text{Rated kW} \times (\text{Actual Voltage}^2 / \text{Rated Voltage}^2).$$

## 4.5 CALCULATING ELECTRIC HEAT CAPACITY IN BTUH

Use the following formula to convert heater kW to heating capacity in BTUH.

$$\text{BTUH Capacity} = \text{kW} \times 3412$$

(Where 3412 = BTUH per kW)

## 4.6 CHECKING INDOOR AIR-FLOW

### 4.6.1 ESTIMATING CFM USING EXTERNAL STATIC PRESSURE

A common method of checking indoor is to measure the external static pressure that the air-handler is working against and then referring to the air-flow data in Section 3.13.3. Measuring external static pressure to a high degree of precision in the field is challenging, so keep in mind that the CFM determined by this method is an estimate, but is accurate enough for all practical purposes.

To determine external static pressure, the static pressure should be measured in inches of water column across the air-handler using an incline manometer, digital static pressure meter, or a Magnahelic. The static pressure inside the return plenum should be measured as close to the air-handler as possible and must be measured between any external filter rack and the unit so the pressure drop across the filter is accounted for. The static pressure inside the supply plenum should be measured at a point about half-way between the air-handler and the first elbow or the end of the plenum. Total external static pressure is the sum of the return and supply plenum static pressures. Even though the return plenum static pressure is a negative pressure, it must be added to the supply plenum static pressure, ignoring the negative sign. The supply and return plenum static pressure tubing can also be connected to both pressure ports of the pressure measuring device which will automatically add the two pressures together.

#### IMPORTANT:

When checking external static pressure in the cooling or heat pump heating mode on (-) H2T models that are matched to a 2-Stage outdoor unit, the thermostat set point must be adjusted so the system is operating in the 2nd stage mode to assure the air-handler is delivering 2nd stage air-flow.

### 4.6.2 ESTIMATING CFM USING ELECTRIC HEAT TEMPERATURE RISE

If the air-handler is equipped with an electric heater, the CFM can be estimated using the air temperature rise across the air-handler with the heater and blower both energized once the unit has run long enough for the temperatures to stabilize. As with determining CFM using external static pressure, the CFM determined by this method is an estimate, but is accurate enough for all practical purposes. Measure the return air temperature as close to the unit as possible and the supply air temperature about half way from the air-handler to the first elbow or end of the supply plenum. Use the following formula to calculate CFM once the temperature rise is determined.

$$\text{CFM} = \text{Heating BTUH} / (\text{Elevation Factor} \times \text{Temp Rise } ^\circ\text{F})$$

**Note:** Refer to Section 4.5 to determine Heating BTUH and the following chart for Elevation Factor.

Elevation (Feet)	Elevation Factor
Sea Level	1.08
500	0.98
1000	0.96
1500	0.95
2000	0.93
2500	0.91
3000	0.90
3500	0.88
4000	0.86
5000	0.83
6000	0.83
7000	0.77
8000	0.74
9000	0.72
10000	0.69

## 4.7 CHECKING REFRIGERANT CHARGE

System refrigerant charging should only be performed after the indoor air-flow is confirmed to be correct for the application. Once the air-flow is confirmed, refer to the manufacturer's outdoor unit charging chart and installation manual for the proper charging procedure for the system.

**Note:** The charging method for systems with a fixed orifice (piston) will likely be different than systems with TXV's.

# 5.0 COMPONENTS & CONTROLS

## 5.1 BLOWER MOTOR

All (-)H1P models have 2-speed single-phase permanent split capacitor (PSC) style motors.

- The 208/240 volt models also have voltage taps that allow the motor to be configured to restore full air-flow performance in 208 volt applications.
- The low speed tap is for applications with duct system external static pressures up to 0.5" W.C. and the high speed tap is for applications with external static pressures from 0.5 – 0.7" W.C.
- A run capacitor is required for the PSC motors which is mounted on the blower housing. Speed and voltage change instructions are detailed in Sections 3.13.1 & 3.13.2 of this manual.

All (-)H2T models have 5-speed constant torque electronically commutated (ECM) style motors that are significantly more efficient than PSC motors.

- The 208/240 volt models **do not** require the motor to be reconfigured for 208 volt applications, although the control transformer must still be reconfigured for 208 volt applications.
- The motor has a control module mounted on the end of the motor opposite the shaft end which is replaceable should only the control module itself fail.
- Constant torque ECM motors do not require a run capacitor.
- A terminal block on the motor shell is provided for the 5 speed taps, labeled T1 – T5. The speed taps are 24VAC inputs. **Do not connect line voltage to these speed taps.** T1 provides the slowest speed and is dedicated to continuous fan operation. T2 – T5 are for cooling & heating operation and are selectable at the terminal block using a single wire with an insulated terminal that plugs onto the terminals in the terminal block. Speed change instructions are detailed in Section 3.13.2.
- The constant torque motor has a built in soft start that will ramp the motor up to speed gradually.
- An off-delay is built into the control of the motor that keeps the motor energized for 30 seconds after 24 volts is removed from all speed tap terminals.

- If two of the speed tap terminals (T1 – T5) are energized with 24 volts simultaneously, the motor will operate at the higher of the 2 speeds. An example of this is when the G and Y thermostat inputs are both energized in the cooling or heat pump heating mode. In this case, T1 (continuous fan) and a higher numbered speed tap will both be energized resulting in the motor operating at the higher speed to support the cooling or heat pump heating air-flow requirement.
- For (-)H2T models matched to a 2-Stage thermostat and 2-Stage outdoor unit, a 2nd stage call for cooling or heat pump heating operation will result in both Y1+Y2 thermostat inputs being energized. The indoor blower motor will operate in the 2nd stage mode based on which terminal the blue (Y2) lead is connected to on the motor low voltage terminal block as long as it is connected to a terminal with a higher number than the yellow (Y1) lead.
- The air-flow delivery rate for a constant torque ECM motor will not decrease as much as it does with a PSC motor as external static pressure increases.

## 5.2 MOTOR RUN CAPACITOR

Only the (-)H1P models have a run capacitors due to the fact they have PSC motors. The capacitor is mounted on the blower housing using a sheet metal strap. The microfarad (mfd) & voltage ratings vary depending on the blower motor and must be replaced with one with the same rating, except 370V rated capacitors can always be replaced with a 440V rated capacitor.

## 5.3 BLOWER CONTROL

An electronic blower control is provided to control blower motor & electric heat operation and is located inside the control box attached to the blower housing. The blower control in the (-)H1P and (-)H2T operate differently as described below.

### (-)H1P Blower Control

- The contacts in the on-board relay (BR) are used to connect line voltage to the motor speed tap when there is a call for motor operation. Motor speed changes are made by switching motor speed taps at this relay.
- The control has an on-board 3 amp automotive style fuse to protect the control circuit.
- A plug on the electric heater kit wiring harness plugs into a 4 pin plug receptacle on the blower control to allow control of the electric heater by the blower control based on thermostat input.
- There is a 5-pin connector for the thermostat pigtail harness to connect to. Wires from the thermostat do not connect directly to the blower control, but rather to the pig-tails that are routed to the exterior of the air-handler cabinet.
- There is a 2 second on-delay for blower operation when there is a call for blower operation.
- There is a 30 second blower off-delay when a call for cooling or heat pump heating ends.
- There is a 75 second blower off-delay when a call for electric heating ends. This allows time for the contacts in the bi-metallic disc type heating sequencer to open which de-energizes the heater elements.

### (-)H2T Blower Control

- There are two 24V outputs on the blower control for controlling the motor, one for continuous fan and one for cooling & heating operation.
- Motor speed changes are made at the motor speed terminal block instead of on the blower control.
- The control has an on-board 3 amp automotive style fuse to protect the control circuit.
- A plug on the electric heater kit wiring harness plugs into a 4 pin plug receptacle on the blower control to allow control of the electric heater by the blower control based on thermostat input.
- There is a 6-pin connector for the thermostat pigtail harness to connect to. Wires from the thermostat do not connect directly to the blower control, but rather to the pig-tails that are routed to the exterior of the air-handler cabinet.
- There is no on-delay for blower operation when there is a call for blower operation.
- There is no blower off-delay provided by the blower control when a call for cooling or heat pump heating ends since a 30 second off-delay is programmed into the constant torque ECM motor.
- There is a blower off-delay programmed into the blower control when a call for electric heating ends. The delay is 45 seconds for the White-Rodgers control and 30 seconds for the UTEC control. This off-delay is added to the 30 second off delay programmed into the motor for a total off-delay of 75 or 60 seconds. This allows time for the contacts in the bi-metallic disc type heating sequencer to open which de-energizes the heater elements.

## 5.4 BLOWER

The blower utilizes a forward curved centrifugal wheel. The blower housing is constructed from galvanized sheet metal. The motor is attached with a 4-arm belly band type mount that screws into the side of the blower housing. The control box attaches to the front of the blower housing for access through the blower access door. The blower slides into place on a track and is secured by 4 sheet metal screws.

## 5.5 TRANSFORMER

A 40VA transformer is located inside the control box attached to the blower housing which provides 24V control voltage for both the air-handler & the outdoor unit. The transformer in 208/240V models is wired from the factory for 240V applications, but has a separate 208V tap for 208V applications. The black wires connected to the 240V tap must be moved to the 208V tap when installing the air-handler in 208V applications to assure full 24V+ control voltage for reliable operation of the system controls.

## 5.6 INDOOR COIL ASSEMBLY

- The indoor coil slabs are a fin & tube design with enhanced aluminum fins & internally grooved aluminum tubing.
- Most models have 3 coil slabs in an “N” configuration, but some models have 2 coil slabs in an “A” configuration.
- All (-)H1P, (-)H2T air-handlers have non-bleed thermal expansion valves (TXV) for refrigerant control.
- All models have a self-draining polypropylene condensate drain pan to eliminate standing water & a painted & insulated sheet metal drip pan to catch any water drips from the coil when the air-handler is oriented in the horizontal position.
- All models have built-in sheet metal channels in various locations designed to manage condensate when the air-handler is oriented in the horizontal position, thus preventing water “blow-off”.
- Copper stubs are provided for field tubing connections.
- The coil assembly slides into the air-handler on sheet metal rails. The coil is installed in the factory for upflow & horizontal left orientations. The coil must be removed and re-installed into the air-handler cabinet 180° from its factory orientation. An additional set of coil support rails must be installed before the coil can be re-installed. The additional set of rails are included with the air-handler for field installation. (See Section 3.2.2)
- The TXV sensing bulb is shipped unattached & must be securely attached to the vapor line with the supplied clamp and insulated with the supplied foam insulation. (See Section 3.10)

# 6.0 ACCESSORIES & KITS

## 6.1 ELECTRIC RESISTANCE HEATER KITS

- All (-)H1P, (-)H2T models are shipped without electric resistance heat.
- Electric heat kits ranging from 3kW to 30kW are available for field installation.
- Refer to Sections 3.13.5, 3.13.6, & 3.13.7 for electric heat kit model numbers available for specific air-handler models along with electrical ratings & additional information regarding the heater kits.
- Heater kit installation instructions are provided with the heater kit.
- All heater kits utilize open wire nickel chromium heating elements.
- An automatic reset over-temperature limit is provided to shut off the heater elements should air-flow become too restricted or if the blower motor fails.
- 13kW kits and larger are designed to operate in 2-stage heat mode if so desired or can be operated as single stage if the W1 & W2 thermostat pigtailed are wired together.
- 208/240V single-phase (“J” Voltage), 208/240V 3-phase (“C” Voltage).
- 115V (“A” Voltage) heater kits are not available.
- 208/240V 3-phase (“C” Voltage) heater kits must be installed in “J” Voltage air-handlers since there are no “C” Voltage air-handlers available. “C” voltage heater kits are for 3-phase applications and allow for smaller wire & fuse/breaker size compared to single-phase “J” Voltage heater kits.
- The heater kit is controlled by the blower control based on thermostat inputs.
- All heater kits are available with a circuit breaker style disconnect.
- 10kW heater kits and smaller are also available with either a pull-out style disconnect

or with no disconnect.

- Incoming electric power is connected directly to the heater kit power terminals.
- The heater kit is provided with 2 power wires that connect to the air-handler power terminal block, providing power to operate the blower motor and controls.
- The heater kit is also provided with a 4-pin connector that plugs into a mating plug on the blower control to allow the control of the heater based on thermostat inputs.

## 6.2 JUMPER BAR KITS

- **Jumper Bar Kit 3 Ckt. to 1 Ckt. RXBJ-A31** is used to convert single phase multiple three circuit units to a single supply circuit. Kit includes cover and screw for line side terminals.
- **Jumper Bar Kit 2 Ckt. to 1 Ckt. RXBJ-A21** is used to convert single phase multiple two circuit units to a single supply circuit. Kit includes cover and screw for line side terminals.

**NOTE:** No jumper bar kit is available to convert three phase multiple two circuit units to a single supply circuit.

## 6.3 AUXILIARY HORIZONTAL OVERFLOW PANS

Cabinet Size	Auxiliary Horizontal Overflow Pan Accessory Model Number
17.5" wide & 3621S	RXBM-AC48
21' & 24.5" wide except 3621S	RXBM-AC61

## 6.4 EXTERNAL FILTER BASES

(See Figure 18)

Model Cabinet Size	Filter Size	Part Number	A	B
17	16 × 20 [406 x 508]	RXHF-17 Accommodate	15.70	17.50
21	20 × 20 [508 x 508]	RXHF-21 1" or 2" filter	19.20	21.00
24	25 × 20 [635 x 508]	RXHF-24	22.70	25.50

**FIGURE 18**  
EXTERNAL FILTER BASE: RXHF-

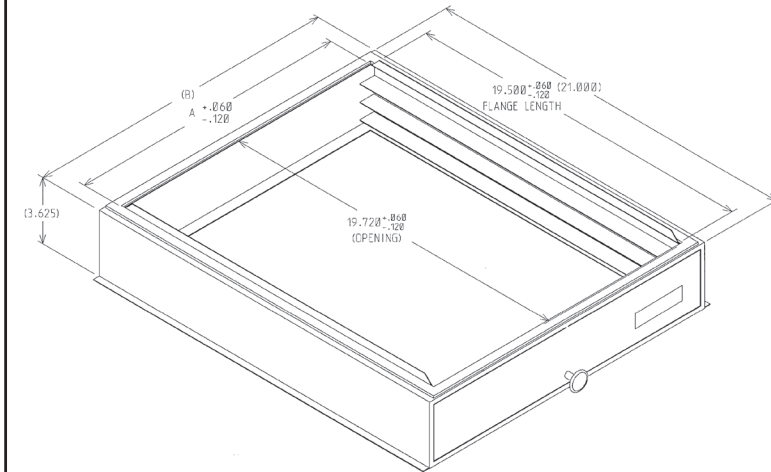

## 6.5 COMBUSTIBLE FLOOR BASES

For high heat downflow applications. (See Section 3.2.2.)

Model Cabinet Size	Combustible Floor Base Model Number
17	RXHB-17
21	RXHB-21
24	RXHB-24



## 6.6 HORIZONTAL ADAPTER KITS

This horizontal adapter kit is used to convert RCH replacement coils for horizontal applications if water management parts from original coil are not usable or are unavailable. See the following table to order proper horizontal adapter kit.

RCH Coil Model	Horizontal Adapter Kit Model Numner (Single Qty.)	Horizontal Adapter Kit Model Number (10-pak Qty.)
2417	RXHH-A02	RXHH-A02x10
3617/3621S	RXHH-A03	RXHH-A03x10
3621M/4821S/4824S	RXHH-A04	RXHH-A04x10
6024S	RXHH-A05	RXHH-A05x10
3621M/4821S/6021S*	RXHH-A06	RXHH-A06x10

\*="A" Coil

## 7.0 MAINTENANCE

For continuing high performance, and to minimize possible equipment failure, it is essential that periodic maintenance be performed on this equipment. Consult your local dealer as to the proper frequency of maintenance and the availability of a maintenance contract.

**IMPORTANT:** Before performing any service or maintenance procedures, see the "Safety Information" (Section 1.0) at the front of this manual.

### WARNING

**Units with circuit breaker(s) meet requirements as a service disconnect switch, however, if access is required to the line side (covered) of the circuit breaker, this side of the breaker(s) will be energized with the breaker(s) de-energized. Contact with the line side can cause electrical shock resulting in personal injury or death.**

### 7.1 AIR FILTER

Check the system filter every ninety days or as often as found to be necessary and if obstructed, clean or replace at once.

A qualified installer, service agency or HVAC professional should instruct the homeowner on how to access filters for regular maintenance.

**IMPORTANT:** Do not operate the system without a filter in place.

- New filters are available from a local distributor or home supply retailer.

### 7.2 INDOOR COIL, DRAIN PAN, DRAIN LINE

Inspect the indoor coil, drain pan, and drain line once each year for cleanliness and clean as necessary. Be sure to check the finned surface on the return side of the coil. It may be necessary to remove the air-filter and use a mirror and flashlight to view the return side of the coil.

**NOTE:** A proper filter is the best defense against a dirty coil. Regardless of the filter choice, proper air flow and velocity also play a crucial role in how effective a filter will be. Most filters will lose their effectiveness when face velocities exceed 300 - 400 feet per minute. Excessive air velocity can allow particles to pass right through the media. Additionally, loaded or restrictive filters may lose their shape in higher air velocity applications and allow unfiltered air to bypass the filter altogether around the sides.

**IMPORTANT:** Coil and Drainpan Cleaning Method

Clean the finned surface of the indoor coil by rinsing the coil from both sides with clean warm water and/or with a vacuum with a soft brush attachment to remove accumulated contaminants and lint. It is important not to allow the tool to damage or bend the fins. Many chemical cleaners will attack the aluminum tubes which can cause refrigerant leaks. Therefore, use only clean warm water for cleaning aluminum tube evaporator coils. Do not use caustic household drain cleaners or bleach in the condensate pan or near the indoor coil as they will damage the aluminum fins and tubes.

### 7.3 BLOWER MOTOR AND WHEEL

Inspect the blower motor and wheel for cleanliness. It should be several years before it would become necessary to clean the blower motor and wheel.

- If it becomes necessary to remove the blower assembly from the unit, see instructions on removal and replacement of motor, blower, and blower wheel in Sections 7.5-7.7 below.
- The blower motor and wheel may be cleaned by using a vacuum with a soft brush attachment. Remove grease with a mild solvent such as hot water and detergent. Be careful not to disturb the balance weights (clips) on the blower wheel blades. Do not drop or bend wheel as balance will be affected.

## 7.4 MOTOR LUBRICATION

The blower motor sleeve bearings are pre-lubricated by the motor manufacturer and do not have oiling ports. Motor should operate for an indefinite period of time without additional lubrication.

## 7.5 BLOWER ASSEMBLY REMOVAL & REPLACEMENT

Removing the blower assembly is not normally required for normal service and maintenance. Removal is necessary for replacement of defective parts such as motor, blower wheel. After extended use, removal of the blower assembly may become necessary for a thorough cleaning of the blower motor and wheel.

### WARNING

**If removal of the blower assembly is required, all disconnect switches supplying power to the equipment must be de-energized and locked (if not in sight of unit) so the field power wires can be safely removed from the blower assembly. Failure to do so can cause electrical shock resulting in personal injury or death.**

- Mark field power supply wiring (for replacement) attached to terminal block or circuit breaker(s) on blower assembly. Remove wiring from terminal block or circuit breaker(s).
- Mark low voltage control wiring (for replacement) where attached to unit control pig-tails on right side of blower housing. Remove wire nuts attaching field control wiring to unit control pigtails.
- Remove 4 screws holding blower assembly to front channel of cabinet and pull blower assembly from cabinet.
- To replace blower assembly, slide blower assembly into blower deck. Make sure blower assembly engages lances in deck properly. If assembly hangs up, check to make sure top and bottom are lined up in proper locations.
- Slide blower assembly to back of cabinet and make sure it is completely engaged.
- Replace 4 screws holding blower assembly to front channel of cabinet. Take care not to strip screws.
- Replace low voltage control wiring with wire nuts and make sure wiring is per the wiring diagram and all connections are tight and secure.
- Replace field power wiring to terminal block or circuit breaker(s) on control area of blower assembly. Make sure wires are connected per the wiring diagram. Tighten supply power wiring securely to terminals lugs.
- Make sure wiring is within cabinet and will not interfere with access door. Make sure there is proper separation between low voltage control wiring and field power wiring.
- Replace blower assembly control access panel before energizing equipment.

## 7.6 MOTOR REPLACEMENT

With the blower assembly removed, the indoor blower motor can be removed and replaced using the following procedure:

- Remove motor leads from the motor capacitor and blower control for (-)H1P or motor terminals for (-)H2T. Note lead locations for ease of reassembly. Pull leads from plastic bushing in blower side.
- Loosen the set screw holding blower wheel onto the motor shaft. The shaft extends through blower hub so that a wrench can be used on the extended shaft to break the shaft loose if necessary. Be careful not to damage shaft. A wheel puller can be used on the groove in the blower hub if necessary.
- Remove 4 screws holding the motor mounts to the blower side and remove motor mount assembly from blower assembly.
- Remove the screw on the belly band strap around the motor shell and remove the 4 mounts from motor.
- Install (four) motor mounts and the belly band strap on the new motor using the screws removed in the previous step.
- Insert the motor shaft through the hub in blower wheel and orient motor to original position with motor leads and motor label facing the front of blower (control area).
- Reassemble 4 screws through motor mounts into blower side. Do not overtorque screws.
- Turn motor shaft so that flat on shaft is located under blower wheel setscrew, and blower wheel is centered in blower housing with the same distance on each side between the inlet orifice and outside of blower wheel. Tighten setscrew on motor shaft. Turn wheel by hand to make sure it runs true without hitting blower sides.
- Reassemble motor wiring to capacitor and blower control for (-)H1P or motor terminals for (-)H2T making sure that wires match wiring diagram and are tight and secure.

## **7.7 BLOWER WHEEL REPLACEMENT**

With the blower assembly removed and the motor assembly removed (see above instructions), remove the screws holding the blower wrap (cutoff) to the blower sides.

- With wrap (cutoff) screws removed, cut off end of blower wrap will spring up. Lifting wrap blower wheel is removed through the discharge opening in the blower housing.
- To replace, make sure wheel is oriented properly with hub to the opposite side from the motor. Lift blower wrap and insert blower wheel through discharge opening in the blower housing.
- Hold blower wrap down into position and replace screws holding blower wrap to blower sides.
- See motor replacement and blower assembly instructions for remaining assembly procedure.

## **7.8 REPLACEMENT PARTS**

Any replacement part used to replace parts originally supplied on equipment must be the same as or an approved alternate to the original part supplied. The manufacturer will not be responsible for replacement parts not designed to physically fit or operate within the design parameters the original parts were selected for.

These parts include but are not limited to: Circuit breakers, heater controls, heater limit controls, heater elements, motor, motor capacitor, blower control, control transformer, blower wheel, indoor coil and sheet metal parts.

When ordering replacement parts, it is necessary to order by part number and include with the order the complete model number and serial number from the unit data plate. (See Parts List for unit component part numbers).

# 8.0 DIAGNOSTICS

Problem	Possible Cause (Suggested Fix)
Blower Motor will not operate	<ul style="list-style-type: none"> <li>• Failed run capacitor on (-)H1P (replace)</li> <li>• Failed motor (replace)</li> <li>• Failed motor control module on (-)H2T (replace module)</li> <li>• Blown 3A fuse on blower control (check for control circuit short, replace fuse)</li> <li>• Loose wiring connection or broken wire (check connections &amp; wiring)</li> <li>• Failed transformer (replace)</li> <li>• Failed blower control (replace)</li> <li>• Disconnect breaker is turned off or has tripped due to over-current or shorted circuit (check for shorts, reset breaker)</li> </ul>
Excessive vibration	<ul style="list-style-type: none"> <li>• Blower wheel out of balance (replace or clean blower wheel)</li> </ul>
Water overflowing drain pan	<ul style="list-style-type: none"> <li>• Plugged drain (clear drain)</li> <li>• Unit not level (level unit)</li> </ul>
Electric heater not heating properly or not heating at all, but blower motor is operating	<ul style="list-style-type: none"> <li>• Over temperature limit has tripped (check for low airflow)</li> <li>• Over temperature limit has failed (replace)</li> <li>• Sequencer or contactor has failed (replace)</li> <li>• One or more heating elements have burned out (replace)</li> </ul>
Coil is frozen up	<ul style="list-style-type: none"> <li>• System low on refrigerant charge (check for leaks &amp; adjust charge)</li> <li>• Dirty return air filter (replace filter)</li> <li>• Inadequate airflow due to incorrect blower motor speed selected (select higher speed) or excessively restrictive duct system (correct duct system)</li> </ul>
Excessive airflow	<ul style="list-style-type: none"> <li>• Incorrect blower motor speed selected (select lower speed)</li> </ul>
Water blow-off from coil	<ul style="list-style-type: none"> <li>• Excessive airflow (select lower blower motor speed)</li> <li>• Contaminants on coil fins (clean coil)</li> <li>• Damaged coil fins (comb out fins or replace coil)</li> </ul>
TXV not controlling properly	<ul style="list-style-type: none"> <li>• TXV bulb not positioned correctly or clamp not tight (Check position of TXV sensing bulb and tightness of clamp)</li> <li>• Failed TXV (replace)</li> <li>• Plugged TXV inlet screen (clean or replace screen or replace TXV)</li> </ul>



# 9.2 WIRING DIAGRAM (-)H1P – 208/240V

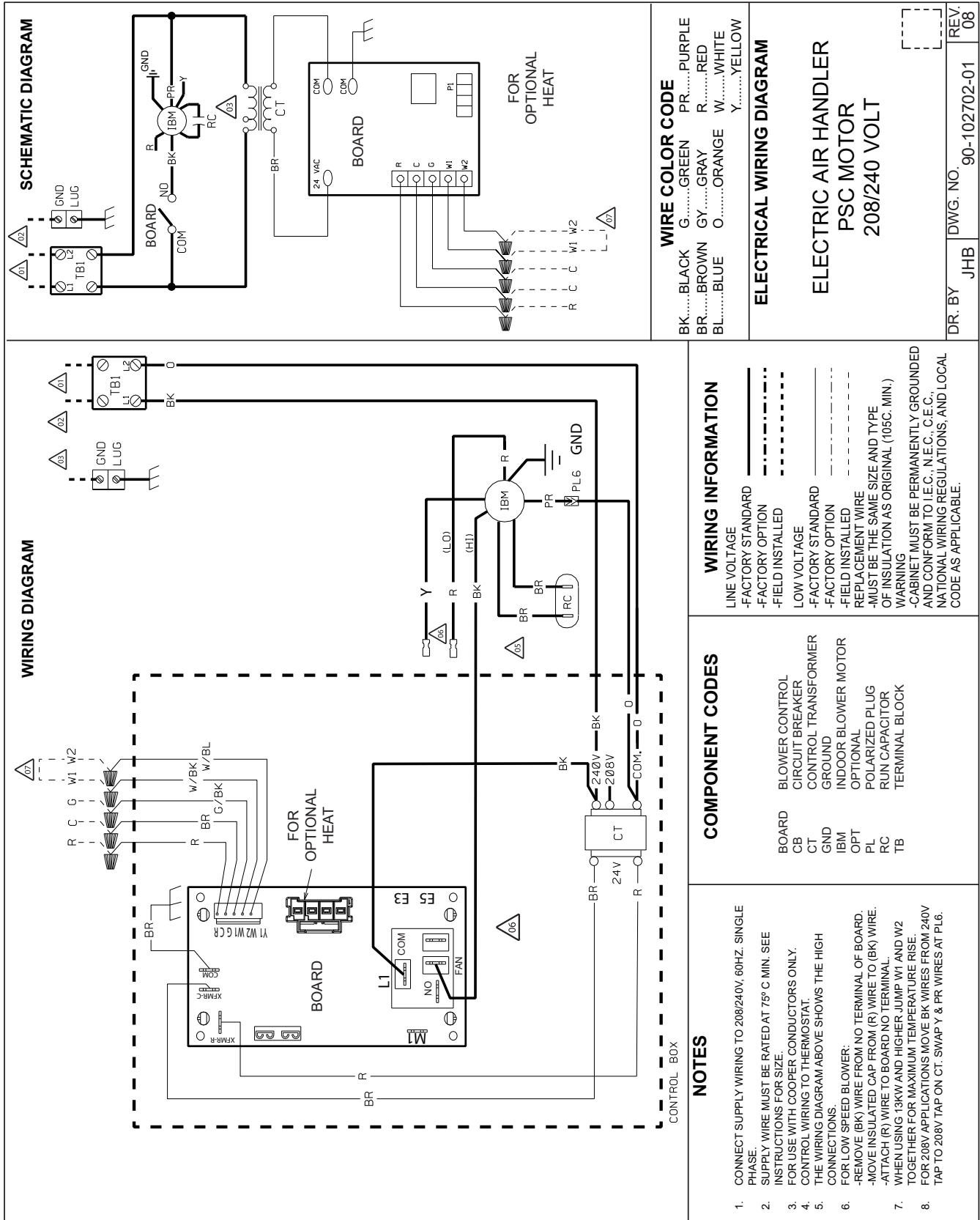

**SCHEMATIC DIAGRAM**

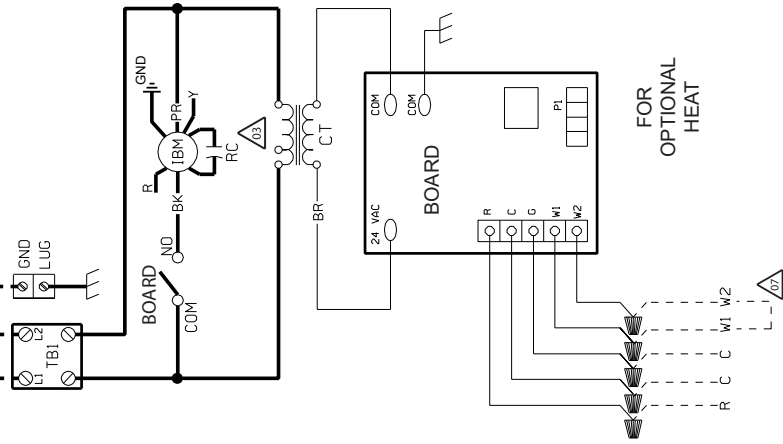

**WIRE COLOR CODE**

- BK.....BLACK G.....GREEN PR.....PURPLE
- BR.....BROWN GY.....GRAY R.....RED
- BL.....BLUE O.....ORANGE W.....WHITE
- Y.....YELLOW

**ELECTRICAL WIRING DIAGRAM**

**ELECTRIC AIR HANDLER  
PSC MOTOR  
208/240 VOLT**

DR. BY JHB DWG. NO. 90-102702-01 REV. 08

**WIRING DIAGRAM**

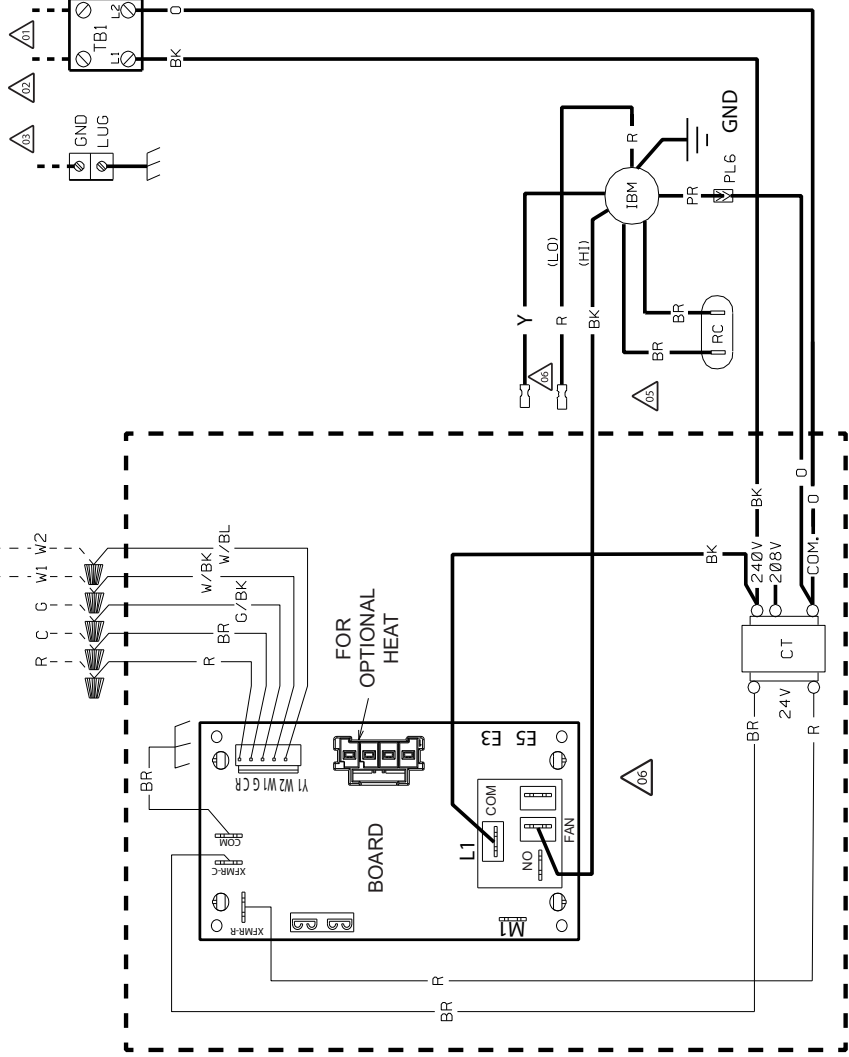

**WIRING INFORMATION**

- LINE VOLTAGE
- FACTORY STANDARD
- FACTORY OPTION
- FIELD INSTALLED
- LOW VOLTAGE
- FACTORY STANDARD
- FACTORY OPTION
- FIELD INSTALLED
- REPLACEMENT WIRE
- MUST BE THE SAME SIZE AND TYPE OF INSULATION AS ORIGINAL (105C. MIN.)
- CABINET MUST BE PERMANENTLY GROUNDED AND CONFORM TO I.E.C. N.E.C. C.E.C. NATIONAL WIRING REGULATIONS, AND LOCAL CODE AS APPLICABLE.

**COMPONENT CODES**

- BOARD
- CB BLOWER CONTROL
- CT CIRCUIT BREAKER
- CONTROL TRANSFORMER
- GND GROUND
- IBM INDOOR BLOWER MOTOR
- OPT OPTIONAL
- PL POLARIZED PLUG
- RC RUN CAPACITOR
- TB TERMINAL BLOCK

**NOTES**

1. CONNECT SUPPLY WIRING TO 208/240V, 60HZ. SINGLE PHASE.
2. SUPPLY WIRE MUST BE RATED AT 75° C MIN. SEE INSTRUCTIONS FOR SIZE.
3. FOR USE WITH COOPER CONDUCTORS ONLY.
4. CONTROL WIRING TO THERMOSTAT.
5. THE WIRING DIAGRAM ABOVE SHOWS THE HIGH CONNECTIONS.
6. FOR LOW SPEED BLOWER:
  - REMOVE (BK) WIRE FROM NO TERMINAL OF BOARD.
  - MOVE INSULATED CAP FROM (R) WIRE TO (BK) WIRE.
  - ATTACH (R) WIRE TO BOARD NO TERMINAL.
7. WHEN USING 13KW AND HIGHER JUMP W1 AND W2 TOGETHER FOR MAXIMUM TEMPERATURE RISE.
8. FOR 208V APPLICATIONS MOVE BK WIRES FROM 240V TAP TO 208V TAP ON CT. SWAP Y & PR WIRES AT PL6.

# 9.3 WIRING DIAGRAM (-)H2T - 115 V

## SCHEMATIC DIAGRAM

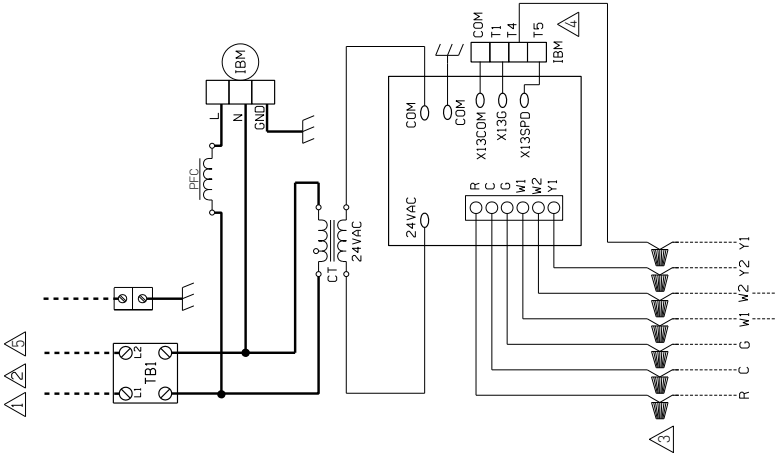

**WIRE COLOR CODE**

BK.....BLACK	G.....GREEN	PR.....PURPLE
BR.....BROWN	GY.....GRAY	R.....RED
BL.....BLUE	O.....ORANGE	W.....WHITE
	Y.....YELLOW	

ELECTRICAL WIRING DIAGRAM  
 ELECTRICAL AIR HANDLER  
 115V X-13 MOTOR

APPROVED: \_\_\_\_\_  
 MODELED BY: VYM  
 CHECKED: \_\_\_\_\_  
 DATE: 6/30/2021  
 ORIGINAL RELEASE NO.: 101443  
 PART NO.: 90-101897-15  
 REV: 02

## SPEED TAP TABLE

TONS	LOW STATIC		HIGH STATIC
	Y1, Y2	T4, T5	
2 TON	Y1, Y2	T2, T3	T4, T5
3 TON	Y1, Y2	T2, T3	T4, T5
4 TON	Y1, Y2	T2, T3	T4, T5
5 TON	Y1, Y2	T2, T3	T4, T5

## WIRING DIAGRAM

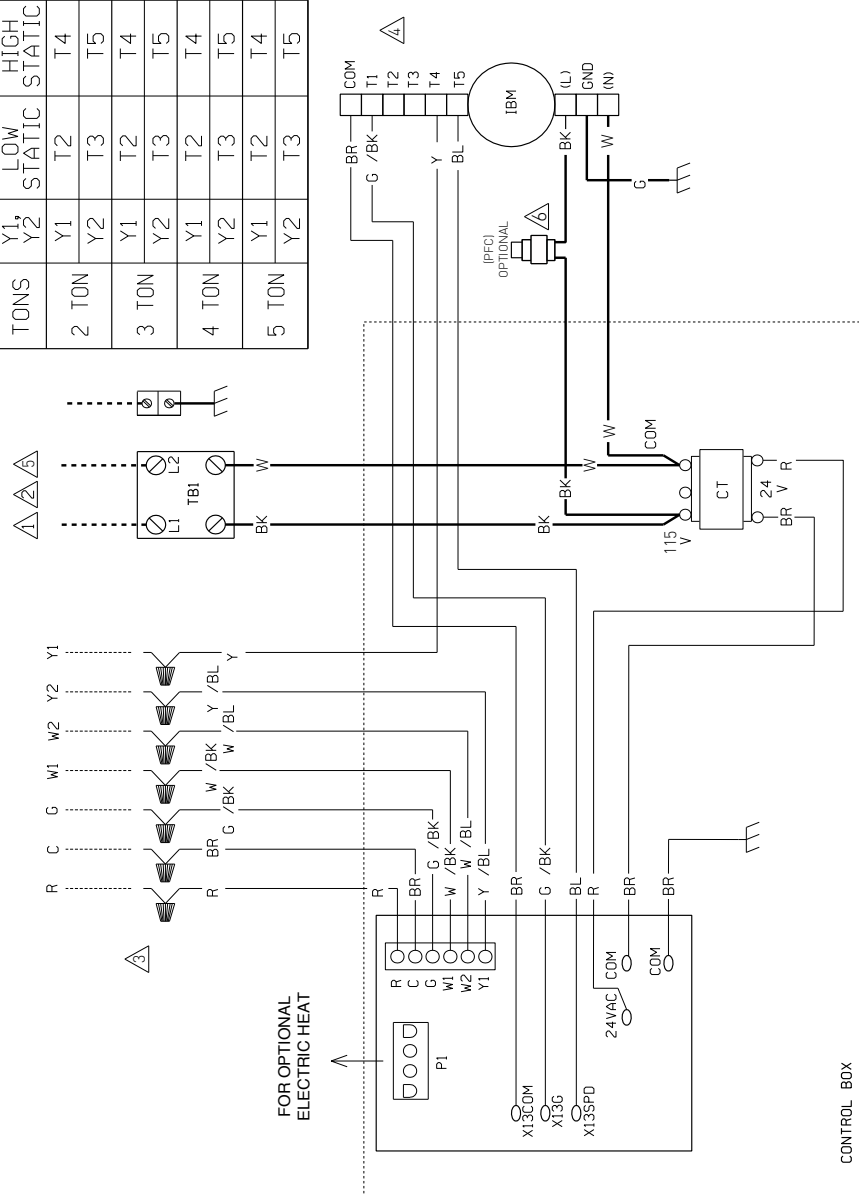

## COMPONENT CODES

- CT CONTROL TRANSFORMER
- GND GROUND
- IBM INDOOR BLOWER MOTOR
- OPT OPTIONAL
- PFC POWER FACTOR CHOKE
- WIRE NUT
- TB TERMINAL BLOCK (HI VOLT)

## NOTES

1. CONNECT SUPPLY WIRING FOR 115 V VOLTAGE, PHASE AND HERTZ SHOWN ON RATING PLATE.
2. SUPPLY WIRE MUST BE RATED AT 75° C MIN. SEE INSTRUCTIONS FOR SIZE.
3. CONTROL WIRING TO THERMOSTAT.
4. BLOWER SPEED SELECT (BL WIRE) IS FACTORY WIRED TO FULL TONNAGE HIGH SPEED TAB T5. (SEE SPEED TAP TABLE FOR ALTERNATE CONFIGURATION)
5. FOR USE WITH COOPER CONDUCTORS ONLY.
6. FOR USE WITH ONLY 3/4" AND 1 HP MOTORS.
7. HEATER KIT CANNOT BE USED ON 115V "A" OR "L" AIRHANDLER MODELS.

## WIRING INFORMATION

- LINE VOLTAGE
- FACTORY STANDARD
- FACTORY OPTION
- FIELD INSTALLED
- LOW VOLTAGE
- FACTORY STANDARD
- FACTORY OPTION
- FIELD INSTALLED
- REPLACEMENT WIRE
- MUST BE THE SAME SIZE AND TYPE OF INSULATION AS ORIGINAL (105C. MIN)
- WARNING
- MUST BE PERMANENTLY GROUNDED AND CONFORM TO I.E.C., N.E.C., AND LOCAL NATIONAL WIRING REGULATIONS, AND LOCAL CODES AS APPLICABLE.

# 9.4 WIRING DIAGRAM (-)H2T - 230V

