

USER'S INFORMATION MANUAL FOR COMMUNICATING MODULATING CONDENSING GAS FURNACES

 Recognize this symbol as an indication of Important Safety Information!



WARNING

IF THE INFORMATION IN THESE INSTRUCTIONS IS NOT FOLLOWED EXACTLY, A FIRE OR EXPLOSION MAY RESULT, CAUSING PROPERTY DAMAGE, PERSONAL INJURY OR DEATH.

FOR YOUR SAFETY

- Do not store or use gasoline or other flammable vapors and liquids, or other combustible materials in the vicinity of this or any other appliance.
- WHAT TO DO IF YOU SMELL GAS
 - Do not try to light any appliance.
 - Do not touch any electrical switch; do not use any phone in your building.
 - Immediately call your gas supplier from a neighbor's phone. Follow the gas supplier's instructions.
 - If you cannot reach your gas supplier, call the fire department.
 - Do not rely on smell alone to detect leaks. Due to various factors, you may not be able to smell fuel gases.
 - U.L. recognized fuel gas and CO detectors are recommended in all applications, and their installation should be in accordance with the manufacturer's recommendations and/or local laws, rules, regulations, or customs.
- **Installation and service must be performed by a qualified installer, service agency or the gas supplier.**

NOTE TO INSTALLER: REVIEW THIS MANUAL WITH THE USER AND LEAVE IT WITH THE EQUIPMENT.

DO NOT DESTROY. PLEASE READ CAREFULLY AND KEEP IN A SAFE PLACE FOR FUTURE REFERENCE.

WARNING

PROPOSITION 65: THIS PRODUCT CONTAINS CHEMICALS KNOWN TO THE STATE OF CALIFORNIA TO CAUSE CANCER, BIRTH DEFECTS OR OTHER REPRODUCTIVE HARM.

GENERAL INFORMATION

▲ WARNING

DUCT LEAKS CAN CREATE AN UNBALANCED SYSTEM AND DRAW POLLUTANTS SUCH AS DIRT, DUST, FUMES AND ODORS INTO THE HOME CAUSING PROPERTY DAMAGE. FUMES AND ODORS FROM TOXIC, VOLATILE OR FLAMMABLE CHEMICALS, AS WELL AS AUTOMOBILE EXHAUST AND CARBON MONOXIDE (CO), CAN BE DRAWN INTO THE LIVING SPACE THROUGH LEAKING DUCTS AND UNBALANCED DUCT SYSTEMS CAUSING PERSONAL INJURY OR DEATH (SEE FIGURE 1).

- IF AIR-MOVING EQUIPMENT OR DUCTWORK IS LOCATED IN GARAGES OR OFF-GARAGE STORAGE AREAS - ALL JOINTS, SEAMS, AND OPENINGS IN THE EQUIPMENT AND DUCT MUST BE SEALED TO LIMIT THE MIGRATION OF TOXIC FUMES AND ODORS INCLUDING CARBON MONOXIDE FROM MIGRATING INTO THE LIVING SPACE.
- IF AIR-MOVING EQUIPMENT OR DUCTWORK IS LOCATED IN SPACES CONTAINING FUEL BURNING APPLIANCES SUCH AS WATER HEATERS OR BOILERS - ALL JOINTS, SEAMS, AND OPENINGS IN THE EQUIPMENT AND DUCT MUST ALSO BE SEALED TO PREVENT DEPRESSURIZATION OF THE SPACE AND POSSIBLE MIGRATION OF COMBUSTION BYPRODUCTS INCLUDING CARBON MONOXIDE INTO THE LIVING SPACE.

▲ NOTICE

IMPROPER INSTALLATION, OR INSTALLATION NOT MADE IN ACCORDANCE WITH THE CSA INTERNATIONAL (CSA) CERTIFICATION OR THESE INSTRUCTIONS, CAN RESULT IN UNSATISFACTORY OPERATION AND/OR DANGEROUS CONDITIONS AND ARE NOT COVERED BY THE UNIT WARRANTY.

▲ NOTICE

IN COMPLIANCE WITH RECOGNIZED CODES, IT IS RECOMMENDED THAT AN AUXILIARY DRAIN PAN BE INSTALLED UNDER ALL EVAPORATOR COILS OR UNITS CONTAINING EVAPORATOR COILS THAT ARE LOCATED IN ANY AREA OF A STRUCTURE WHERE DAMAGE TO THE BUILDING OR BUILDING CONTENTS MAY OCCUR AS A RESULT OF AN OVERFLOW OF THE COIL DRAIN PAN OR A STOPPAGE IN THE PRIMARY CONDENSATE DRAIN PIPING. SEE ACCESSORIES SECTION OF THESE INSTRUCTIONS FOR AUXILIARY HORIZONTAL OVERFLOW PAN INFORMATION (MODEL RXBM).

IMPORTANT INFORMATION ABOUT EFFICIENCY AND INDOOR AIR QUALITY

Central cooling and heating equipment is only as efficient as the duct system that carries the cooled or heated air. To maintain efficiency, comfort and good indoor air quality, it is important to have the proper balance between the air being supplied to each room and the air returning to the cooling and heating equipment.

Proper balance and sealing of the duct system improves the efficiency of the heating and air conditioning system and improves the indoor air quality of the home by reducing the amount of airborne pollutants that enter homes from spaces where the ductwork and / or equipment is located. The manufacturer and the U.S. Environmental Protection Agency's Energy Star Program recommend that central duct systems be checked by a qualified contractor for proper balance and sealing.

- Some building codes require extra cabinet insulation and gasketing when unit is installed in attic applications.
- If installed in an unconditioned space, apply caulking around the power wires, control wires, refrigerant tubing and condensate line where they enter the cabinet. Seal the power wires on the inside where they exit conduit opening. Caulking is required to prevent air leakage into and condensate from forming inside the unit, control box, and on electrical controls.
- Install the unit in such a way as to allow necessary access to the coil/filter rack and blower/control compartment.
- Install the unit in a level position to ensure proper condensate drainage. Make sure unit is level in both directions within 1/8".
- Install the unit in accordance with any local code which may apply and the national codes. Latest editions

FIGURE 1

MIGRATION OF DANGEROUS SUBSTANCES, FUMES, AND ODORS INTO LIVING SPACES

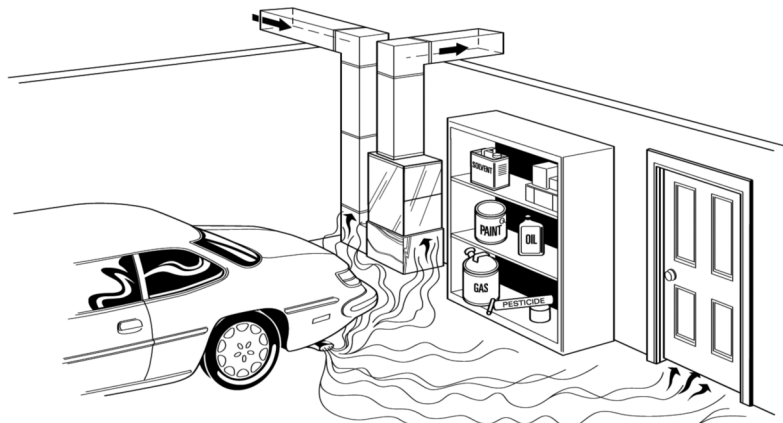

Adapted from *Residential Duct Diagnostics and Repair*, with permission of Air Conditioning Contractors of America (ACCA).

RECEIVING

Immediately upon receipt, all cartons and contents should be inspected for transit damage. Units with damaged cartons should be opened immediately. If damage is found, it should be noted on the delivery papers, and a damage claim filed with the last carrier.

- After unit has been delivered to job site, remove carton taking care not to damage unit.
- Check the unit rating plate for unit size, electric heat, coil, voltage, phase, etc. to be sure equipment matches what is required for the job specification.
- Read the entire instructions before starting the installation.

are available from: "National Fire Protection Association, Inc., Batterymarch Park, Quincy, MA 02269." These publications are:

- ANSI/NFPA No. 70-(Latest Edition) National Electrical Code.
- NFPA90A Installation of Air Conditioning and Ventilating Systems.
- NFPA90B Installation of warm air heating and air conditioning systems.
- The equipment has been evaluated in accordance with the Code of Federal Regulations, Chapter XX, Part 3280.

INTRODUCTION TO YOUR FURNACE

Thank you for the purchase of your new modulating gas furnace! This furnace is designed to be the ultimate in heating comfort and is the only true modulating gas furnace available on the market today.

The modulating gas furnace provides a superior level of comfort due to the interaction of seven basic components:

- **Variable Output Thermostat** - Whereas conventional thermostats only send an On/Off signal to the furnace, the thermostat for the modulating furnace system is specially designed to indicate the exact heating requirements of the conditioned space. This is accomplished by a logic control routine that accurately senses the space load, minimizes recovery times, reduces temperature swings and optimizes system efficiency and performance.
- **Fully Communicating Thermostat Modulating Gas Valve** - The gas valve has the conventional redundant solenoid valves for inherent safety, but also has a third operator for capacity control. This operator is actually a servo valve

which varies the input rate of the furnace proportionally to the signal from the controller. The modulating furnace can operate anywhere from 40% to 100% of the nameplate input of the furnace.

- **Furnace Controller** - The furnace controller provides all of the ignition and safety functions of the typical IFC as well as interpreting the signals from the thermostat. The furnace controller will optimize furnace performance by monitoring all thermostat and temperature inputs and insuring the stable operation of the inducer, gas valve and indoor blower motor.
- **ECM Variable Speed Blower** - The airflow through the duct work is varied to meet the load demand. Airflow as low as 300 CFM is achieved by the response of a brushless permanent magnet variable speed blower motor.
- **Two Speed Draft Inducer** - To insure clean combustion and peak efficiency, the induced draft motor speed is adjusted based on the gas valve setting to provide the proper amount of combustion air to the burners.

**FIGURE 2
UPFLOW FURNACE**

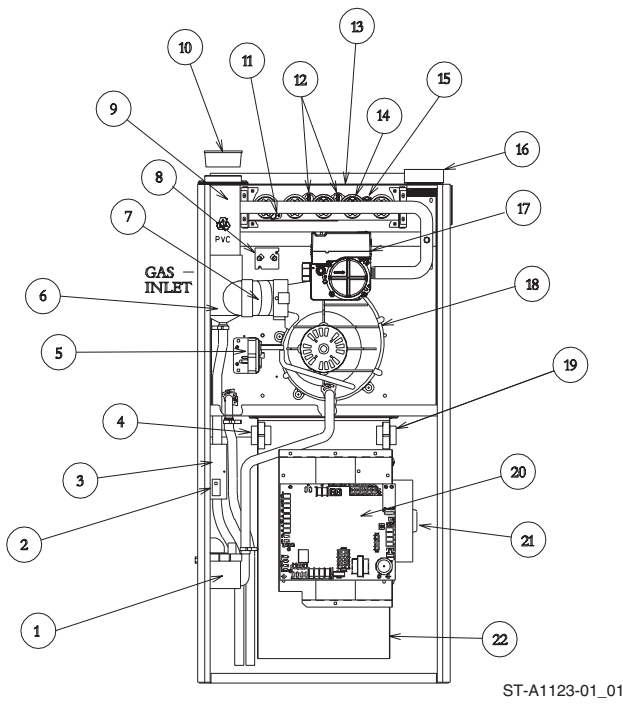

ST-A1123-01_01

ITEM NO.	PART NAME	ITEM NO.	PART NAME
1	CONDENSATE TRAP	13	TOP PLATE
2	DOOR SWITCH	14	BURNER
3	JUNCTION BOX	15	IGNITER
4	TRANSFORMER	16	COMBUSTION AIR INLET
5	PRESSURE SWITCH ASSEMBLY	17	GAS VALVE
6	EXHAUST TRANSITION	18	INDUCED DRAFT BLOWER
7	CONNECTOR	19	POWER FACTOR CHOKE
8	MAIN LIMIT	20	INTEGRATED FURNACE CONTROL
9	EXHAUST AIR PIPE	21	BLOWER MOTOR
10	VENT CAP SHIPPING PLUG	22	BLOWER HOUSING
11	FLAME SENSOR		
12	OVERTEMPERATURE SWITCH		

**FIGURE 3
DOWNFLOW FURNACE**

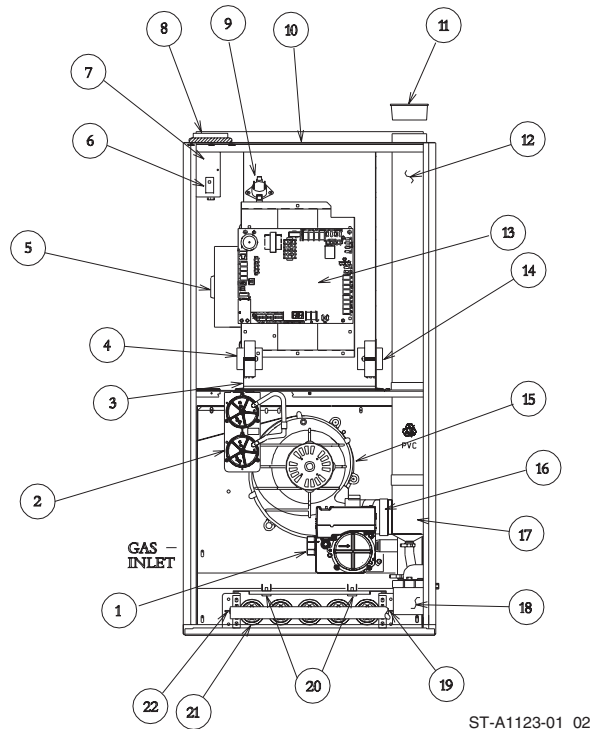

ST-A1123-01_02

ITEM NO.	PART NAME	ITEM NO.	PART NAME
1	GAS VALVE	13	INTEGRATED FURNACE CONTROL
2	PRESSURE SWITCH ASSEMBLY	14	TRANSFORMER
3	BLOWER HOUSING	15	INDUCED DRAFT BLOWER
4	POWER FACTOR CHOKE	16	CONNECTOR
5	BLOWER MOTOR	17	EXHAUST TRANSITION
6	DOOR SWITCH	18	CONDENSATE TRAP
7	JUNCTION BOX	19	IGNITER
8	COMBUSTION AIR INLET	20	OVERTEMPERATURE SWITCH
9	HALC	21	BURNER
10	TOP PLATE	22	FLAME SENSOR
11	VENT CAP SHIPPING PLUG		
12	OUTLET AIR PIPE		

► **FIGURE 3**
HORIZONTAL FURNACE (-)GJD

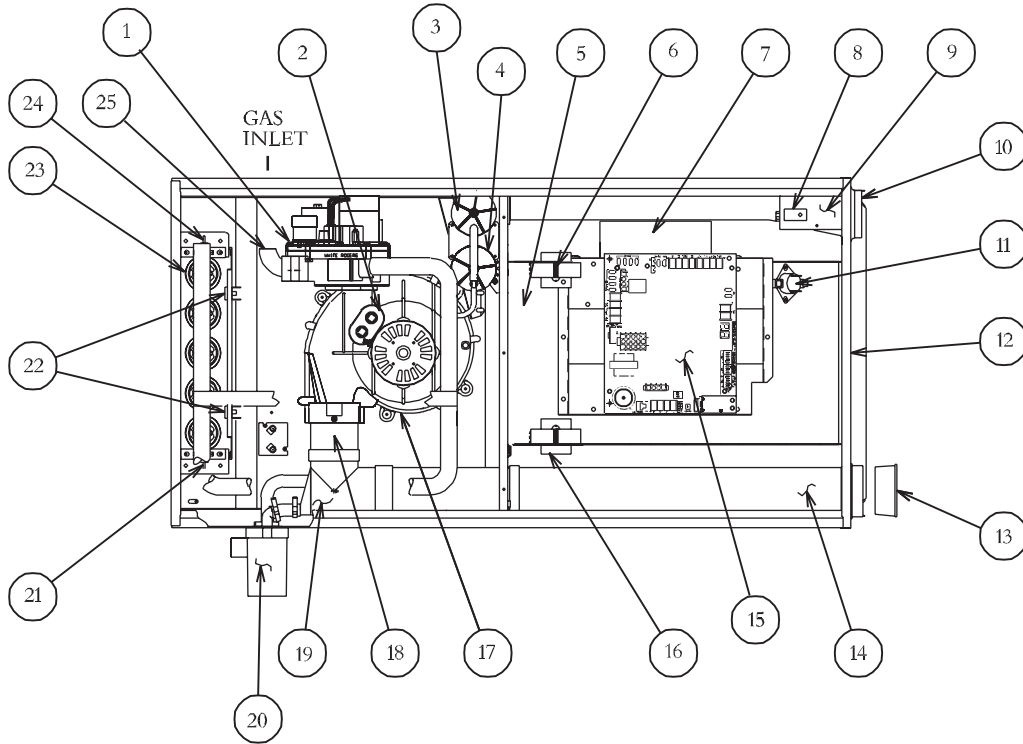

ITEM NO.	PART NAME	ITEM NO.	PART NAME
1	GAS VALVE	14	OUTLET AIR PIPE
2	CAPACITOR (FOR INDUCER)	15	INTEGRATED FURNACE CONTROL
3	LOW PRESSURE SWITCH	16	TRANSFORMER
4	HIGH PRESSURE SWITCH	17	INDUCED DRAFT BLOWER
5	BLOWER HOUSING	18	CONNECTOR
6	POWER FACTOR CHOKE	19	EXHAUST TRANSITION
7	BLOWER MOTOR	20	CONDENSATE TRAP
8	DOOR SWITCH	21	IGNITER
9	JUNCTION BOX	22	OVERTEMPERATURE SWITCH
10	COMBUSTION AIR INLET	23	BURNER
11	HALC	24	FLAME SENSOR
12	TOP PLATE	25	FACTORY-INSTALLED STREET ELBOW
13	VENT CAP PLUG		

ST-A107801.S01

- *Supply Air Sensors* - This thermister assembly, is a field installed air probe, communicate the furnace temperature rise to the integrated furnace control. The integrated furnace control uses this information to calculate field conditions during calibration to insure optimal efficiency and comfort during normal operation.

This furnace has been designed to give you many years of efficient, dependable home comfort. With regular maintenance, this furnace will operate superbly year after year.

Please take the time to fill out the information below and read this manual to familiarize yourself with operation, maintenance schedule, and safety operation.

IMPORTANT: READ THESE INSTRUCTIONS THOROUGHLY BEFORE ATTEMPTING TO OPERATE THIS FURNACE.

INSTALLATION INFORMATION

Date Installed _____

Dealer Name _____

Address _____

City _____

State _____ Zip _____

Telephone No. _____

AC SYSTEM

Model No. _____

Serial No. _____

INDOOR COIL

Model No. _____

Serial No. _____

FURNACE

Model No. _____

Serial No. _____

SAFETY PRECAUTIONS SIGNAL WORDS

There are some safety precautions which must be understood and followed by all users of equipment such as your furnace, where flames, gas, electricity and rotating parts are present. To alert you to the above potential hazards, we use the signal words "WARNING" and "CAUTION" throughout this manual and safety labels attached to the furnace.

Read carefully and pay special attention to all warnings and cautions in this manual. They are defined and designed as follows to help you recognize and avoid the potential hazards of operating this furnace:

▲ WARNING

Indicates a potentially hazardous situation which, if not avoided, could result in property damage, serious injury or death.

▲ CAUTION

Indicates a potentially hazardous situation which, if not avoided, could result in property damage, or minor or moderate injury.

POSSIBILITY OF FIRE OR EXPLOSION

▲ WARNING

THIS FURNACE OPERATES BY BURNING GAS INSIDE YOUR HOME. THIS CREATES THE POSSIBILITY OF FIRE OR AN EXPLOSION WHICH CAN RESULT IN PROPERTY DAMAGE, PERSONAL INJURY OR DEATH. YOU MUST READ AND FOLLOW ALL OF THESE SAFETY PRECAUTIONS TO HELP ENSURE SAFE OPERATION OF YOUR FURNACE.

- Do not test for gas leaks with a match or flame.
- Do not use this furnace with any other gas than the one listed on the rating plate.
- Follow the furnace lighting instructions carefully to be sure all gas fumes are cleared before lighting the furnace.
- Check carefully for gas before lighting a furnace. Do not rely on smell alone to detect gas. Use a UL recognized fuel gas detector and a soap and water solution on the pipes to check for gas leaks.
- A damaged gas control knob can cause gas to leak. Do not hit or damage the knob. Do not force the knob with tools. Use only your hand to turn it to "ON" or "OFF". Call the a quali-

fied installer, service agency or the gas supplier immediately if you have problems turning the knob.

- Should overheating occur, or the gas valve fail to shut off the gas supply, turn off the manual gas valve to the furnace before turning off the electrical supply.
- Soot buildup indicates a serious combustion problem that requires immediate correction. Turn the gas supply "OFF" until the furnace is repaired. Contact a qualified installer, service agency or the gas supplier immediately to inspect the furnace.
- Do not place, store or use gasoline or other flammable vapors and liquids on, against, or around the furnace jacket.
- Do not store combustible materials near the furnace. The furnace must have adequate clearances from all combustible materials such as clothing, paper, cardboard, wood or cleaning materials to prevent them from igniting.
- Keep any furnace installed in an attic or other insulated space free and clear of insulating material. Examine the furnace area when installing the furnace or adding insulation. Some materials may be combustible.
- Any additions, changes or conversions required in order for the furnace to satisfactorily meet the application needs should be made by a qualified installer, service agency or the gas supplier, using factory specified or

approved parts. Read your Warranty. Contact the WARRANTOR for conversion information. This furnace was equipped at the factory for use on NATURAL GAS ONLY. Conversion to LP GAS requires a special kit supplied by the WARRANTOR.

DANGER FROM ASPHYXIATION

▲ WARNING

THIS FURNACE OPERATES BY BURNING GAS INSIDE YOUR HOME. IMPROPER OR INCOMPLETE BURNING OF THIS GAS CAN RESULT IN THE FORMATION OF CARBON MONOXIDE. IF INTRODUCED INTO THE LIVING SPACE, THIS CAN CAUSE DIZZINESS, NAUSEA, OR DEATH BY ASPHYXIATION. YOU MUST READ AND OBSERVE THE SAFETY RULES BELOW TO PREVENT OXYGEN DEPLETION OR UNBURNED GAS OR COMBUSTION FROM ESCAPING INTO THE LIVING SPACE OF YOUR RESIDENCE.

- Do not operate this furnace without provisions for an adequate combustion air supply.
- Do not allow snow, ice, or any other debris to accumulate in or around the exhaust and intake terminations of this furnace. These are extended through the roof or horizontally through the sidewall of the structure. See Figures 5 & 6. Blockage of the intake and exhaust can result in inadequate combustion air as well as inadequate unit performance or nuisance tripping.

FIGURE 5
STANDARD VERTICAL
DIRECT VENTING

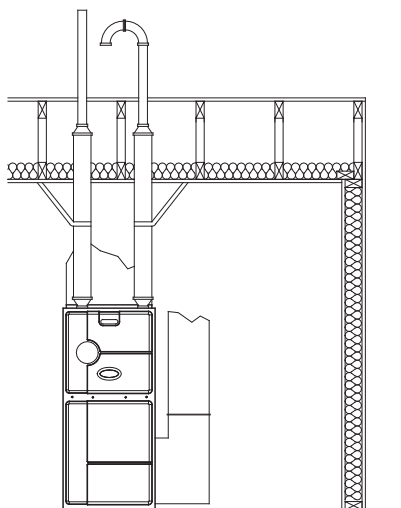

1407

FIGURE 6
STANDARD HORIZONTAL
DIRECT VENTING

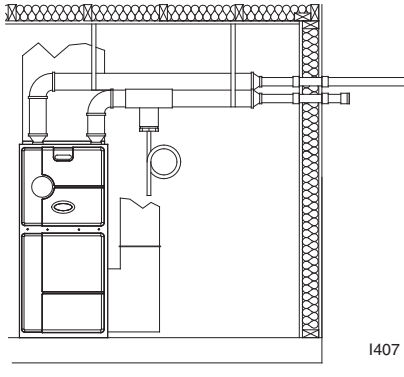

1407

- Prevent flue gases from escaping into your residence. Deterioration of the venting system, or soot build-up can cause leaks into the system. Have a qualified installer, service agency or the gas supplier replace damaged parts or repair obstructions in a deteriorated vent system immediately.
- Do not use this furnace if any part has been under water. A flood-damaged furnace is extremely dangerous. Attempts to use the furnace can result in fire or explosion. A qualified service agency should be contacted to inspect the furnace and to replace all gas controls, control system parts, electrical parts that have been wet or the furnace, if deemed necessary.
- To prevent carbon monoxide poisoning, all blower doors and compartment covers must be replaced after the furnace is serviced. Do not operate the unit without all panels and doors securely in place.

SYSTEM OPERATION INFORMATION

- Keep the air filters clean. Your heating system will operate more efficiently and provide better heating, more economically.
- Arrange your furniture and drapes so that the supply air registers and return air grilles are unobstructed.
- Close doors and windows. This will reduce the heating load on your system.
- Avoid excessive use of exhaust fans.
- Do not permit the heat generated by television, lamps, or radios to influence the thermostat operation.
- If you desire to operate your system with constant air circulation, consult your thermostat manual or please ask advice from a qualified installer, service agency or the gas supplier.

IMPORTANT: FOR COMPLETE OPERATION AND SET UP OF YOUR THERMOSTAT REFER TO THE MANUAL INCLUDED IN THE LITERATURE PACKET SHIPPED WITH THIS FURNACE.

STARTING YOUR FURNACE

LIGHTING INSTRUCTIONS

This appliance is equipped with a direct spark ignition device. This device lights the main burners each time the room thermostat calls for heat. **DO NOT** try to light the burner by hand. See lighting instructions on the furnace.

1. Remove the burner access door.
2. Set the thermostat to the lowest setting.
3. Turn the gas control knob counter-clockwise to the "ON" position.
4. Replace the burner access door.
5. Turn on the electrical power.
6. Set the room thermostat to a point above the room temperature to light the main burners. After the burners are lit, set the room thermostat to a desired temperature.

▲ WARNING

BE SURE THAT THE MANUAL GAS CONTROL HAS BEEN IN THE "OFF" POSITION FOR AT LEAST FIVE MINUTES. DO NOT ATTEMPT TO MANUALLY LIGHT THE MAIN BURNERS. FAILURE TO FOLLOW THIS WARNING CAN CAUSE A FIRE OR AN EXPLOSION RESULTING IN PROPERTY DAMAGE, PERSONAL INJURY OR DEATH.

7. If the appliance will not operate, follow the instructions "To Turn Off Gas To The Appliance" and call your service technician or gas supplier.

TO TURN OFF GAS TO THE APPLIANCE

▲ WARNING

SHOULD OVERHEATING OCCUR OR THE GAS SUPPLY FAIL TO SHUT OFF, SHUT OFF THE MANUAL GAS VALVE TO THE APPLIANCE BEFORE SHUTTING OFF THE ELECTRICAL SUPPLY. FAILURE TO DO SO CAN CAUSE AN EXPLOSION OR FIRE RESULTING IN PROPERTY DAMAGE, PERSONAL INJURY OR DEATH.

IMPORTANT: SHUT OFF THE MANUAL GAS VALVE LOCATED IN THE GAS SUPPLY PIPING OUTSIDE THE FURNACE CASING.

1. Set the thermostat to the lowest setting.
2. Turn off all electric power to the appliance on which service is to be performed.
3. Remove the burner access door.
4. Turn the gas control knob to the "OFF" position.
5. Replace the burner access door.

SEQUENCE OF OPERATION

Startup For Systems Configured With Communications

▲ WARNING

INSTALLATION OF LINE VOLTAGE AND GAS MUST BE PERFORMED ACCORDING TO INSTRUCTIONS WRITTEN IN THIS MANUAL. FAILURE TO DO SO COULD RESULT IN INJURY OR DEATH.

When the furnace is configured for communications, the components on the network (i.e. furnace, thermostat and condenser) must establish communications before engaging a heat (or other) thermostat demand. The procedure for establishing communications is automatic and is described below.

Once the communicating wiring is properly installed and the furnace is connected to line voltage, the system can be turned on. The thermostat will display the following text :

SEARCHING

is displayed several times for several seconds. Next, the text

FURNACE FOUND

and

AIR CONDITIONER FOUND

or

HEAT PUMP FOUND

(depending on which is installed in the system) will be displayed. The process can take several minutes (up to a maximum of 30) to complete. If these messages are not displayed within 30 minutes after energizing the system, communications can not be established. There are many reasons why communications may not be established – including improper settings of the “TERM” and “BIAS” switches (see BIAS/ TERMINATION) and improper wiring.

The order in which these messages will be displayed will depend on which components are energized first. The

order listed here assumes that the furnace and condenser are energized at the same time. If not, the order of display will be in the order that the components are turned on.

When the system has found all necessary components, the text area of the communicating thermostat will go blank. This is an indicator that the system is operating properly. Proceed by engaging a typical thermostat call to determine if operation is correct as described in the section of this book titled “START UP PROCEDURES” to test heating, cooling and fan operation and to make necessary adjustments.

Heating Cycle Initiation

The heating cycle is always initiated by a 24 volt signal on W of the thermostat. When the controller senses a heat call or with a communicating signal from a communicating thermostat, the following sequence occurs:

- High and low pressure switches are checked to insure contacts are open.
- Inducer is powered on high speed for a thirty (30) second prepurge.
- Pressure switches are monitored as the inducer creates the vacuum to close the contacts.
- The gas valve servo or solenoid is energized at 100%. (No flow yet.)
- The controller generates a spark across the electrodes.
- The main solenoid on the gas valve is energized, allowing gas to flow to the burners.
- When flame is proven, the ignition control is de-energized - 8 second maximum trial time.
- The gas valve maintains 100% rate through the warm-up period - 20 seconds.

Heating Cycle Response

The heating cycle is always initiated by a 24 volt signal on W1 or with a communicating signal from a communicating thermostat. When the controller senses a heat call, the following sequence occurs:

MODULATING FUNCTION:

(“W” and “V” signal inputs, refer to dip switch set SW2 on IFC)

After the warm-up period, the furnace will respond to the thermostat demand by adjusting the gas valve pressure and blower speed anywhere between 40% to 100% heating capacity.

► TWO-STAGE FUNCTION:

(Two-stage function only applies when both switches of SW2 are in the “ON” position and a two-stage thermostat is installed 24V.)

After the warm-up period, the furnace will respond to the thermostat demand by adjusting the gas valve pressure and blower heating speeds to the “W” signal values. “W” only = 40% gas valve pressure and blower heating speed. “W2” = 65% gas valve pressure and blower heating speed for first five minutes and 100% thereafter. Also, if the call for heat ends, the furnace terminates at the present rate.

► SINGLE-STAGE FUNCTION:

(“W” signal only)

After the warm-up period, the furnace will respond to the thermostat demand by altering the gas valve pressure and blower speed as follows:

Phase 1: 0 to 5 minutes = 40% of furnace capacity (gas valve output and blower speed)

Phase 2: 5 to 12 minutes = 65% of furnace capacity (gas valve output and blower speed)

Phase 3: After 12 minutes = 100% of furnace capacity (gas valve output and blower speed)

NOTE: If the call for heat ends during any phase, the furnace will terminate immediately at the firing rate of that phase.

Heating Cycle Termination

(“W” signal only, refer to dip switch set SW2 on IFC)

When the heat call is removed, the heating cycle will end and the furnace will shut down and return to the proper off cycle operation.

MAINTENANCE

IMPORTANT: IT IS RECOMMENDED THAT AN ANNUAL INSPECTION OF YOUR FURNACE BE MADE BY A QUALIFIED INSTALLER, SERVICE AGENCY OR THE GAS SUPPLIER. DURING THE ANNUAL INSPECTION, IT IS RECOMMENDED THAT 120VAC POWER BE TURNED OFF, THEN BACK TO THE ON POSITION. REAPPLYING 120VAC INITIATES A CALIBRATION CYCLE TO ENSURE OPTIMUM SYSTEM OPERATION.

▲ WARNING

THIS FURNACE CONTAINS MOVING/ROTATING COMPONENTS AND USES HOUSEHOLD ELECTRICAL CURRENT. FOLLOW THE SAFETY RULES BELOW TO AVOID CUTS, BURNS OR ELECTRICAL SHOCK WHICH CAN RESULT IN SEVERE PERSONAL INJURY OR DEATH.

POSSIBILITY OF BURNS OR ELECTRICAL INJURY

- Do not perform any service or maintenance on the furnace while it is operating. Read and follow the service instructions provided with this furnace before beginning any service or maintenance work.
- Do not open the blower compartment, disassemble, or remove any components while the furnace is operating. This may expose sharp edges or points which could cause cuts, hot surfaces which could cause burns, and electrical circuits which could cause shocks.

- Instruct children on the safety hazards associated with furnaces. Keep children away from the furnace at all times.

CAUTION

DO NOT OPERATE YOUR SYSTEM FOR EXTENDED PERIODS WITHOUT FILTERS. A PORTION OF THE DUST ENTRAINED IN THE AIR MAY TEMPORARILY LODGE IN THE AIR DUCT RUNS AT THE SUPPLY REGISTERS. ANY RECIRCULATED DUST WILL BE HEATED AND CHARRED BY CONTACT WITH THE FURNACE HEAT EXCHANGER. THIS RESIDUE WILL SOIL CEILINGS, WALLS, DRAPES, CARPETS AND OTHER HOUSEHOLD ARTICLES.

FILTER MAINTENANCE

Have your qualified installer, service agency or the gas supplier instruct you on how to access your filters for regular maintenance.

- Keep air filters clean at all times. Vacuum dirt from filter, wash with detergent and water, air dry thoroughly and reinstall.
- After filters are cleaned and returned to the furnace, be sure doors are properly reinstalled. If you are not totally sure of this procedure, consult qualified installer, service agency or the gas supplier.

REMOVING FILTERS

FILTER IN BOTTOM OR SIDE LOCATION

FIGURE 7
UPFLOW SIDE FILTER LOCATION

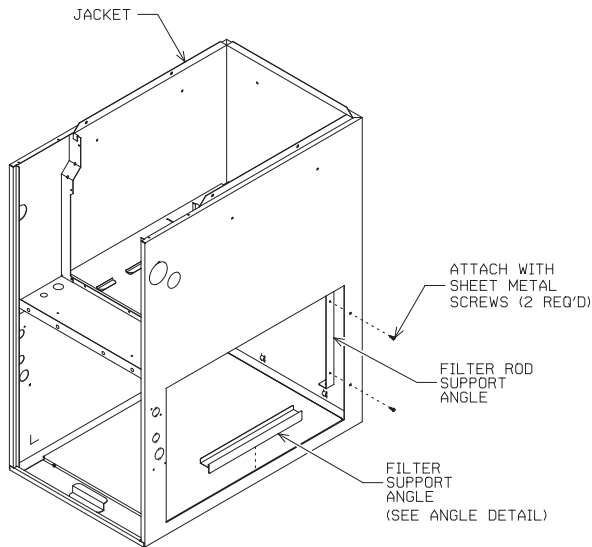
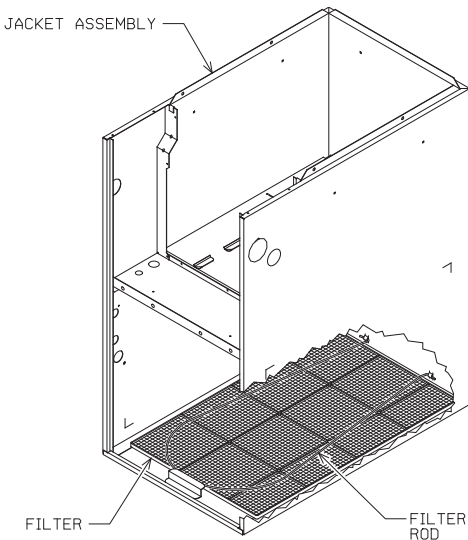

FIGURE 8
UPFLOW BOTTOM FILTER INSTALLATION



1. Remove the blower compartment access door.
2. Disengage the filter retaining rod and pull filter out.
3. Clean filter and reinstall.
4. Replace the blower compartment access door.

LUBRICATION

The blower motor and induced draft motor are permanently lubricated by the manufacturer and do not require further attention.

IMPORTANT: DO NOT ATTEMPT TO LUBRICATE THE BEARINGS ON THE BLOWER MOTOR OR THE INDUCED DRAFT BLOWER MOTOR. ADDITION OF LUBRICANTS CAN REDUCE THE MOTOR LIFE AND VOID THE WARRANTY.

The blower compartment and motor should be inspected and cleaned periodically by your qualified installer, service agency or the gas supplier to prevent the possibility of overheating due to an accumulation of dust and dirt on the windings or on the motor exterior. And, as suggested elsewhere in these instructions, keep the air filters clean because dirty filters can restrict airflow and the motor depends on sufficient air flowing across and through it to keep it from overheating.

COMBUSTION AIR AND VENT SYSTEM

1. It is recommended that an annual inspection of your furnace's combustion air and vent system be done by a qualified installer, service agency or the gas supplier.

WARNING

IF DIRT, RUST, SOOT OR SCALE ACCUMULATIONS ARE PRESENT, DO NOT OPERATE THE FURNACE. INSPECT THE HEAT EXCHANGER FOR LEAKS. LEAKS CAN CAUSE TOXIC FUMES TO ENTER THE HOME AND CAUSE CARBON MONOXIDE POISONING OR DEATH.

2. Turn OFF the electrical supply to the furnace and remove the access doors.
3. Inspect the gas burners for dirt, rust or scale and clean as necessary.
4. Inspect the flue connection area and vent pipe. Be sure that the vent connector is in place and slopes upward and is physically sound, without holes or excessive corrosion.
5. Be sure that the return air duct connections are physically sound, are sealed to the furnace casing and terminate outside the space containing the furnace.

▲ WARNING

CHECK THE VENT PIPE SECTIONS FOR DETERIORATION AND CHECK JOINT FITTINGS FOR THEIR INTEGRITY. IF IT HAS BECOME DISCONNECTED TOXIC FUMES CAN ENTER THE HOME AND CAUSE CARBON MONOXIDE POISONING OR DEATH. DO NOT OPERATE THIS FURNACE. APPROPRIATE SERVICE MUST BE APPLIED.

6. Be sure the physical support of the furnace is sound, without sags, cracks, etc. around the base so as to provide a seal between the support and the base.
7. Look for the obvious signs of deterioration of the furnace.
8. If the furnace is free of the above conditions, replace the access doors and restore electrical power to the furnace.
9. Start the furnace and observe its operation. Watch the burner flames to see if they are bright blue. If a suspected malfunction is observed, or the burner flames are not bright blue, call for appropriate service.

CONDENSATE

This furnace is equipped with a pressure switch which will shut off the main burners if the condensate drain line becomes blocked.

Be sure this condensate drain line does not become blocked or plugged. Visual inspection of the condensate flow can easily be made while the furnace is in operation. Use a flashlight to illuminate the discharge end placed in the sewer opening. See Figures 11, 12 & 13.

Clean and flush the condensate tube to make sure condensate flows freely while the furnace is in operation.

IMPORTANT: IT IS RECOMMENDED THAT AT THE BEGINNING OF THE HEATING SEASON, THE CONDENSATE TRAP BE INSPECTED BY A QUALIFIED INSTALLER, SERVICE AGENCY OR THE GAS SUPPLIER FOR DEBRIS OR BLOCKAGE. A BLOCKED CONDENSATE TRAP CAN CAUSE WATER TO BACK UP INTO THE PRIMARY HEAT EXCHANGER AND LEAD TO NUISANCE TRIPPING OF THE OVER TEMPERATURE SWITCHES OR PRESSURE SWITCHES.

IMPORTANT: IT IS RECOMMENDED THAT AT THE BEGINNING OF THE HEATING SEASON THE CONDENSATE NEUTRALIZER, IF USED, BE REPLACED BY A QUALIFIED INSTALLER, SERVICE AGENCY OR THE GAS SUPPLIER.

MARKINGS

It is recommended that an annual inspection and cleaning of all furnace markings be made to assure legibility. Attach a replacement marking, which can be obtained through the distributor, if any are found to be illegible or missing.

FIGURE 9
DOWNFLOW FILTER INSTALLATION

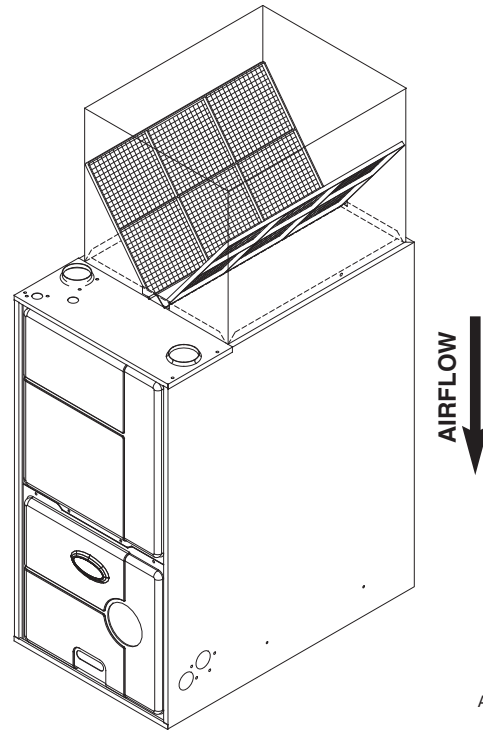

A087001.S01

FIGURE 10
HORIZONTAL -- FILTER INSTALLATION
((-)GJD MODELS)

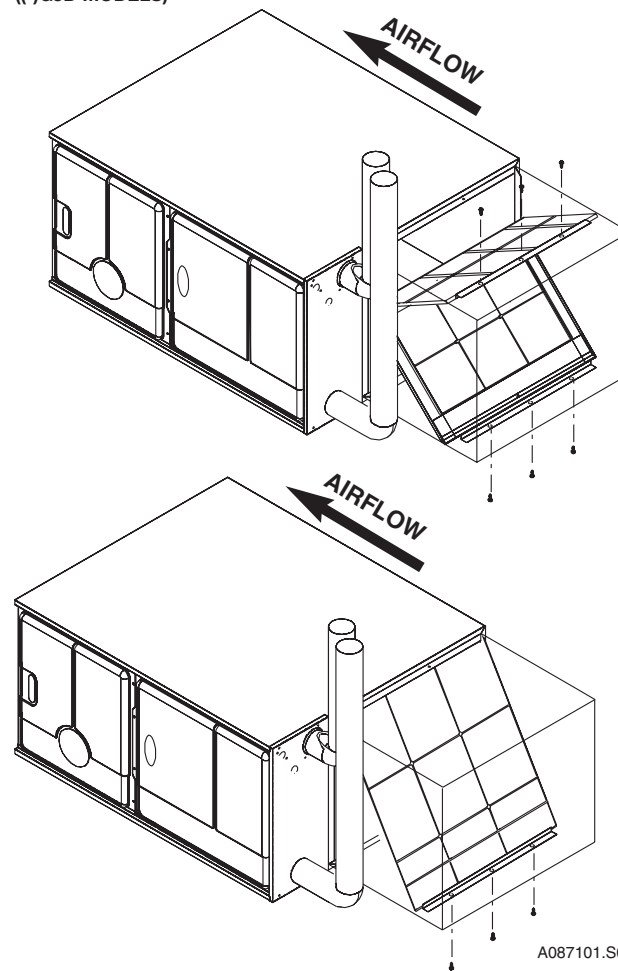

A087101.S01

FIGURE 11
UPFLOW CONDENSATE DRAIN

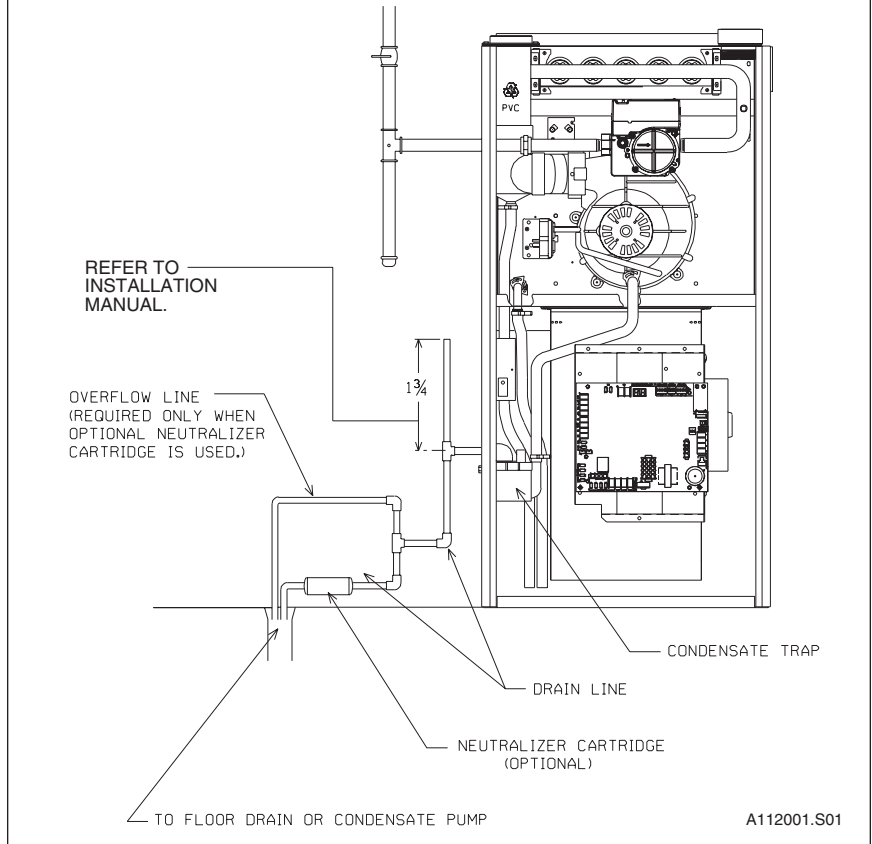

FIGURE 12
DOWNFLOW CONNECTION

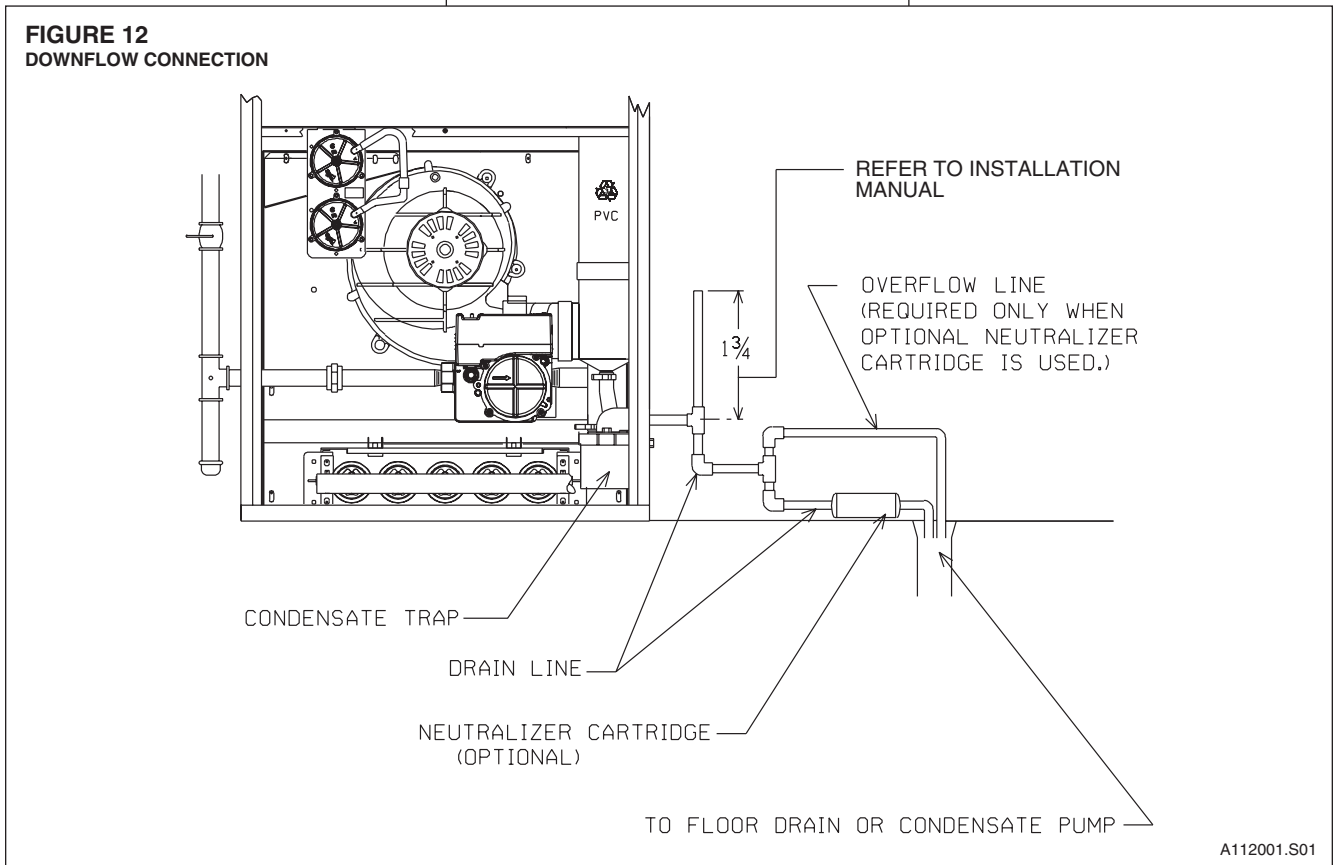

FIGURE 13
HORIZONTAL CONDENSATE DRAIN

