



The new degree of comfort.™

## Rheem *Classic*® Series Package Gas Electric Unit



### **RGEA14- 14 SEER Series**

Nominal Sizes 2-5 Tons [7.0-17.6 kW]

### **RGEA15- 15 SEER Series**

Nominal Sizes 2-5 Tons [7.0-17.6 kW]

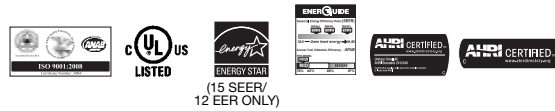

## TABLE OF CONTENTS

Unit Features & Benefits .....	3-4
Model Number Identification .....	5
Options .....	6
General Data	
RGEA14- Series .....	7-16
RGEA15- Series .....	17-32
General Data Notes .....	33
Gross Systems Performance Data	
RGEA14- Series .....	34-39
RGEA15- Series .....	40-45
Indoor Airflow Performance	
RGEA13- Series .....	46-51
RGEA15- Series .....	52-55
Electrical Data	
RGEA14- Series .....	56-60
RGEA15- Series .....	61-63
Dimensional Data .....	64-65
Typical Installations .....	66
Accessories .....	67-75
Wiring Diagrams .....	76-84
Limited Warranty .....	85

## Package Gas Electric Unit Features:

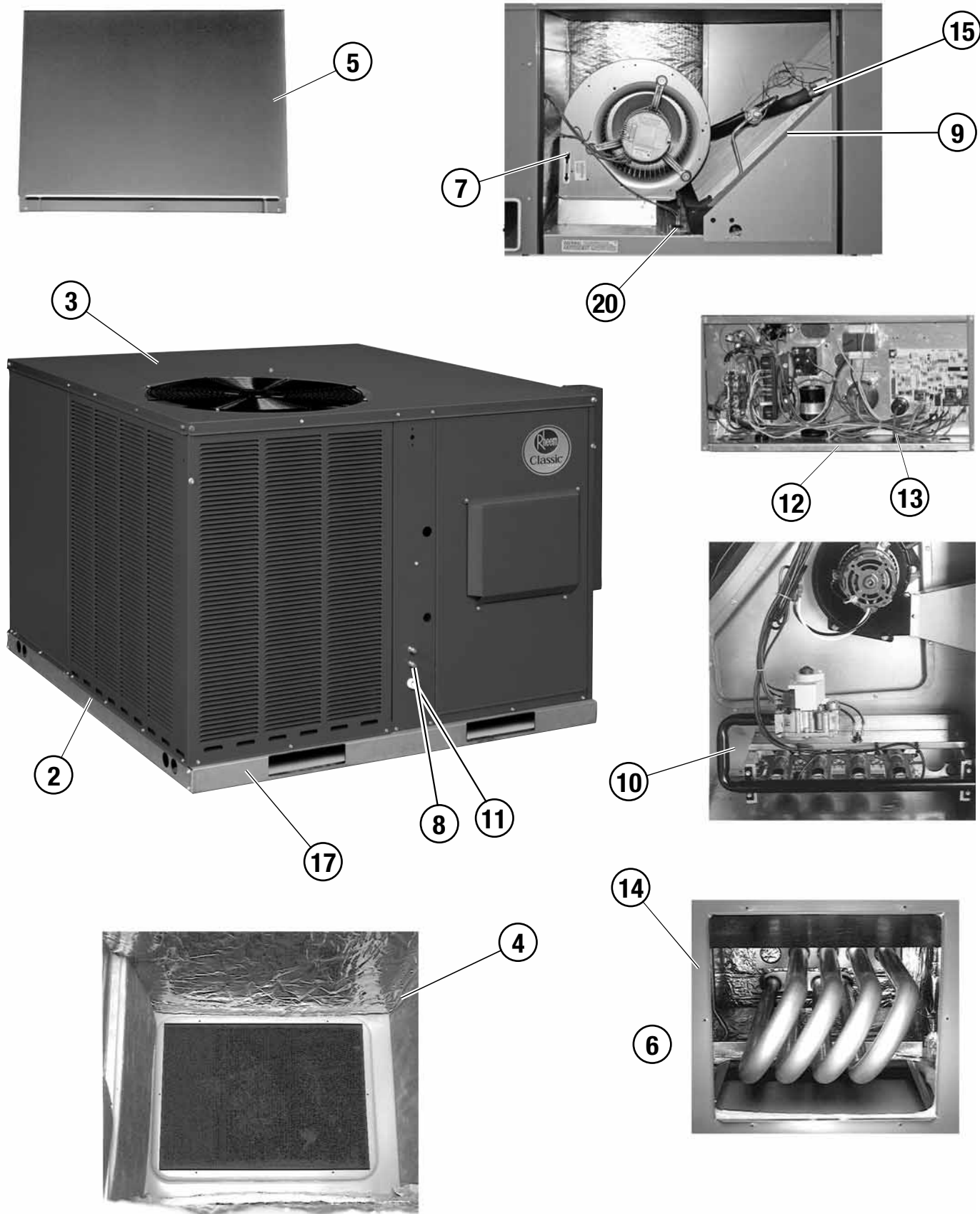



## RGEA14/15 Features Below Correspond to Photos on Page 3

1. All models feature Scroll® compressors for maximum efficiency and quiet operation. 5 Ton RGEA15 models feature UltraTech™ Scroll 2-Stage compressors with Comfort Alert™ diagnostics (see below), high/low pressure switches, and hard start kits.
2. Louvered condenser compartment for protecting the coil against yard hazards and/or weather extremes.
3. One-piece top with a deep flange to help keep water out of the unit.
4. Supply and return air openings feature a one-inch tall flange to prevent water migration into the ductwork.
5. Access panels have “weep holes” and channels to further help manage water run-off.
6. Side and down discharge options available on all models. All models are shipped ready for horizontal application.
7. Easily accessible blower section complete with slide-out blower.
8. Refrigerant connections are conveniently located for easy service diagnostics.
9. Micro Channel evaporator and condenser delivers superior performance with less refrigerant charge and less weight than conventional copper tube/aluminum fin coils. In addition the all aluminum construction has superior protection against formicary corrosion and aluminum tube rubbing potential. Its easier to clean and has a more robust surface.
10. Inside the easily accessible furnace compartment is the draft inducer motor. This motor is specially designed for quiet reliable operation. In addition to the draft inducer motor, the in-shot gas burners and manifold efficiently regulate the flow of gas for combustion. These new gas/electric units also feature direct-spark ignition and remote flame sensors for added reliability and efficiency.
11. All units feature an internal trap on the condensate line eliminating the need for installing an on-site external trap.
12. Easily accessible control box.
13. Single point wiring simplifies installation.
14. Our gas/electric package units feature a tubular heat exchanger design. Tubular heat exchangers are more efficient and durable than older-style clamshell heat exchangers. The heat exchanger is backed by a 10 year limited warranty. Models with a stainless steel heat exchanger installed in a residential application are backed by a limited lifetime warranty.
15. Thermal expansion valve standard on all models for superior superheat control, reliability, and energy efficiency at all operating conditions.
16. Filter drier standard on all models (not shown).
17. Rugged baserail included for improved installation and handling
18. Complete factory charged, wired and run tested.
19. Molded compressor plugs.
20. A double sloped evaporator coil drain pan assures all water is removed from the unit to improve indoor air quality.

### Comfort Alert™ Diagnostics – Faster Service And Improved Accuracy (2-Stage Models Only)

The Comfort Alert™ diagnostics module is a breakthrough innovation for troubleshooting air conditioning system failures. The module is installed in the control box near the compressor contactor. By monitoring and analyzing data from the Scroll® compressor and the thermostat demand, the module can accurately detect the cause of electrical and system related failures without any sensors. A flashing LED indicator communicates the ALERT code and guides the service technician more quickly and accurately to the root cause of a problem.

**NOTE: Single phase module does not provide safety protection! The Comfort Alert module is a monitoring device and cannot control or shut down the compressor unless used with a White Rodgers IF95-CA397 Thermostat.**

**NOTE: Three phase module provides compressor protection and will shut down the compressor when compressor damaging conditions are detected.**

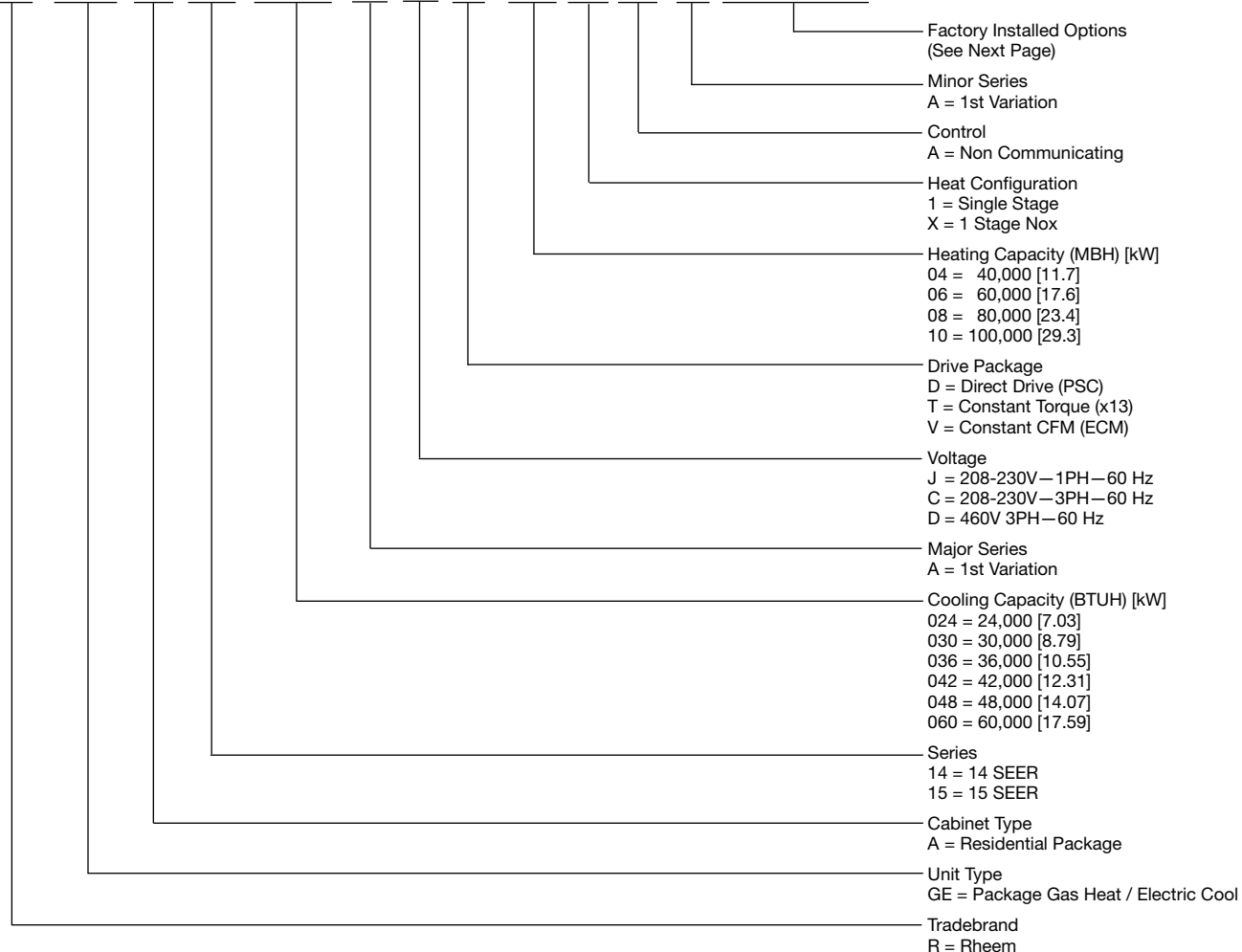

**R GE A 14 036 A J D 10 1 A A X X X**

[ ] Designates Metric Conversions

## Instructions for Factory Installed Option(s) Selection

**Note:** Three characters following the model number will be utilized to designate a factory-installed option or combination of options. If no factory option(s) is required, nothing follows the model number.

**Step 1.** After a basic rooftop model is selected, choose a *three-character* option code from the FACTORY INSTALLED OPTION SELECTION TABLE.

### FACTORY INSTALLED OPTION CODES

Option Code	Stainless Steel Heat Exchanger	Tin Plated Hairpin Coil
AJA	X	

"x" indicates factory installed option.

Example: No Option

RGEA14036AJD081AA

Example: Option with Stainless Steel Heat Exchanger

RGEA14036AJD081AAAJA

Note: Factory installed economizer is not available on these models.

## NOMINAL SIZES 2-5 TONS [7.0-17.6 kW]

Model RGEA14 Series	024AJD041AA	024AJD04XAA	024AJD061AA
<b>Cooling Performance<sup>1</sup></b>			
Gross Cooling Capacity Btu [kW]	24,800 [7.27]	24,800 [7.27]	24,800 [7.27]
EER/SEER <sup>2</sup>	11.6/14	11.6/14	11.6/14
Nominal CFM/AHRI Rated CFM [L/s]	800/900 [378/425]	800/900 [378/425]	800/900 [378/425]
AHRI Net Cooling Capacity Btu [kW]	24,000 [7.03]	24,000 [7.03]	24,000 [7.03]
Net Sensible Capacity Btu [kW]	18,000 [5.27]	18,000 [5.27]	18,000 [5.27]
Net Latent Capacity Btu [kW]	6,000 [1.76]	6,000 [1.76]	6,000 [1.76]
Net System Power kW	2.07	2.07	2.07
<b>Heating Performance (Gas)<sup>3</sup></b>			
Heating Input Btu [kW]	40,000 [11.72]	40,000 [11.72]	60,000 [17.58]
Heating Output Btu [kW]	32,000 [9.38]	32,000 [9.38]	48,000 [14.06]
Temperature Rise Range °F [°C]	25-55 [13.9-30.6]	25-55 [13.9-30.6]	40-70 [22.2-38.9]
AFUE % <sup>4</sup>	81	81	81
Steady State Efficiency (%)	82	82	82
No. Burners	2	2	2
No. Stages	1	1	1
Gas Connection Pipe Size in. [mm]	0.5 [12.7]	0.5 [12.7]	0.5 [12.7]
<b>Compressor</b>			
No./Type	1/Scroll	1/Scroll	1/Scroll
<b>Outdoor Sound Rating (dB)<sup>5</sup></b>			
	76	76	76
<b>Outdoor Coil—Fin Type</b>			
Tube Type	Louvered	Louvered	Louvered
MicroChannel Depth in. [mm]	MicroChannel	MicroChannel	MicroChannel
Face Area sq. ft. [sq. m]	0.71 [18]	0.71 [18]	0.71 [18]
Rows / FPI [FPcm]	7.1 [0.66]	7.1 [0.66]	7.1 [0.66]
	1 / 23 [9]	1 / 23 [9]	1 / 23 [9]
<b>Indoor Coil—Fin Type</b>			
Tube Type	Louvered	Louvered	Louvered
MicroChannel Depth in. [mm]	MicroChannel	MicroChannel	MicroChannel
Face Area sq. ft. [sq. m]	1 [25.4]	1 [25.4]	1 [25.4]
Rows / FPI [FPcm]	3.6 [0.33]	3.6 [0.33]	3.6 [0.33]
	1 / 17 [7]	1 / 17 [7]	1 / 17 [7]
Refrigerant Control	TX Valves	TX Valves	TX Valves
Drain Connection No./Size in. [mm]	1/0.75 [19.05]	1/0.75 [19.05]	1/0.75 [19.05]
<b>Outdoor Fan—Type</b>			
No. Used/Diameter in. [mm]	Propeller	Propeller	Propeller
Drive Type/No. Speeds	1/22 [558.8]	1/22 [558.8]	1/22 [558.8]
CFM [L/s]	Direct/1	Direct/1	Direct/1
No. Motors/HP	2500 [1180]	2500 [1180]	2500 [1180]
Motor RPM	1 at 1/3 HP	1 at 1/3 HP	1 at 1/3 HP
	1075	1075	1075
<b>Indoor Fan—Type</b>			
No. Used/Diameter in. [mm]	FC Centrifugal	FC Centrifugal	FC Centrifugal
Drive Type	1/9x7 [229x178]	1/9x7 [229x178]	1/9x7 [229x178]
No. Speeds	Direct	Direct	Direct
No. Motors	Multiple	Multiple	Multiple
Motor HP	1	1	1
Motor RPM	1/4	1/4	1/4
Motor Frame Size	1075	1075	1075
	48	48	48
<b>Filter—Type</b>			
Furnished	Field Supplied	Field Supplied	Field Supplied
(NO.) Size Recommended in. [mm x mm x mm]	No	No	No
	(1)1x20x20 [25x508x508]	(1)1x20x20 [25x508x508]	(1)1x20x20 [25x508x508]
<b>Refrigerant Charge Oz. [g]</b>			
	42.7 [1211]	42.7 [1211]	42.7 [1211]
<b>Weights</b>			
Net Weight lbs. [kg]	398 [181]	398 [181]	403 [183]
Ship Weight lbs. [kg]	408 [185]	408 [185]	413 [187]

CONTINUED →

See Page 33 for Notes.

[ ] Designates Metric Conversions

## NOMINAL SIZES 2-5 TONS [7.0-17.6 kW]

Model RGEA14 Series	024AJD06XAA	030AJD061AA	030AJD06XAA	030AJD081AA
<b>Cooling Performance<sup>1</sup></b>				<b>CONTINUED</b> →
Gross Cooling Capacity Btu [kW]	24,800 [7.27]	29,600 [8.67]	29,600 [8.67]	29,600 [8.67]
EER/SEER <sup>2</sup>	11.6/14	12/14	12/14	12/14
Nominal CFM/AHRI Rated CFM [L/s]	800/900 [378/425]	1000/1000 [472/472]	1000/1000 [472/472]	1000/1000 [472/472]
AHRI Net Cooling Capacity Btu [kW]	24,000 [7.03]	28,400 [8.32]	28,400 [8.32]	28,400 [8.32]
Net Sensible Capacity Btu [kW]	18,000 [5.27]	21,200 [6.21]	21,200 [6.21]	21,200 [6.21]
Net Latent Capacity Btu [kW]	6,000 [1.76]	7,200 [2.11]	7,200 [2.11]	7,200 [2.11]
Net System Power kW	2.07	2.37	2.37	2.37
<b>Heating Performance (Gas)<sup>3</sup></b>				
Heating Input Btu [kW]	60,000 [17.58]	60,000 [17.58]	60,000 [17.58]	80,000 [23.44]
Heating Output Btu [kW]	48,000 [14.06]	48,000 [14.06]	48,000 [14.06]	65,000 [19.04]
Temperature Rise Range °F [°C]	40-70 [22.2-38.9]	35-65 [19.4-36.1]	35-65 [19.4-36.1]	35-65 [19.4-36.1]
AFUE % <sup>4</sup>	81	81	81	81
Steady State Efficiency (%)	82	82	82	82
No. Burners	2	3	3	3
No. Stages	1	1	1	1
Gas Connection Pipe Size in. [mm]	0.5 [12.7]	0.5 [12.7]	0.5 [12.7]	0.5 [12.7]
<b>Compressor</b>				
No./Type	1/Scroll	1/Scroll	1/Scroll	1/Scroll
<b>Outdoor Sound Rating (dB)<sup>5</sup></b>	76	76	76	76
<b>Outdoor Coil—Fin Type</b>	Louvered	Louvered	Louvered	Louvered
Tube Type	MicroChannel	MicroChannel	MicroChannel	MicroChannel
MicroChannel Depth in. [mm]	0.71 [18]	0.71 [18]	0.71 [18]	0.71 [18]
Face Area sq. ft. [sq. m]	7.1 [0.66]	9.9 [0.92]	9.9 [0.92]	9.9 [0.92]
Rows / FPI [FPcm]	1 / 23 [9]	1 / 23 [9]	1 / 23 [9]	1 / 23 [9]
<b>Indoor Coil—Fin Type</b>	Louvered	Louvered	Louvered	Louvered
Tube Type	MicroChannel	MicroChannel	MicroChannel	MicroChannel
MicroChannel Depth in. [mm]	1 [25.4]	1 [25.4]	1 [25.4]	1 [25.4]
Face Area sq. ft. [sq. m]	3.6 [0.33]	3.6 [0.33]	3.6 [0.33]	3.6 [0.33]
Rows / FPI [FPcm]	1 / 17 [7]	1 / 23 [9]	1 / 23 [9]	1 / 23 [9]
Refrigerant Control	TX Valves	TX Valves	TX Valves	TX Valves
Drain Connection No./Size in. [mm]	1/0.75 [19.05]	1/0.75 [19.05]	1/0.75 [19.05]	1/0.75 [19.05]
<b>Outdoor Fan—Type</b>	Propeller	Propeller	Propeller	Propeller
No. Used/Diameter in. [mm]	1/22 [558.8]	1/22 [558.8]	1/22 [558.8]	1/22 [558.8]
Drive Type/No. Speeds	Direct/1	Direct/1	Direct/1	Direct/1
CFM [L/s]	2500 [1180]	2500 [1180]	2500 [1180]	2500 [1180]
No. Motors/HP	1 at 1/3 HP	1 at 1/3 HP	1 at 1/3 HP	1 at 1/3 HP
Motor RPM	1075	1075	1075	1075
<b>Indoor Fan—Type</b>	FC Centrifugal	FC Centrifugal	FC Centrifugal	FC Centrifugal
No. Used/Diameter in. [mm]	1/9x7 [229x178]	1/10x9 [254x229]	1/10x9 [254x229]	1/10x9 [254x229]
Drive Type	Direct	Direct	Direct	Direct
No. Speeds	Multiple	Multiple	Multiple	Multiple
No. Motors	1	1	1	1
Motor HP	1/4	1/2	1/2	1/2
Motor RPM	1075	1075	1075	1075
Motor Frame Size	48	48	48	48
<b>Filter—Type</b>	Field Supplied	Field Supplied	Field Supplied	Field Supplied
Furnished	No	No	No	No
(NO.) Size Recommended in. [mm x mm x mm]	(1)1x20x20 [25x508x508]	(1)1x24x24 [25x610x610]	(1)1x24x24 [25x610x610]	(1)1x24x24 [25x610x610]
<b>Refrigerant Charge Oz. [g]</b>	42.7 [1211]	46.8 [1327]	46.8 [1327]	46.8 [1327]
<b>Weights</b>				
Net Weight lbs. [kg]	403 [183]	403 [183]	403 [183]	408 [185]
Ship Weight lbs. [kg]	413 [187]	413 [187]	413 [187]	418 [190]

See Page 33 for Notes.

[ ] Designates Metric Conversions

## NOMINAL SIZES 2-5 TONS [7.0-17.6 kW]

Model RGEA14 Series	030AJD08XAA	036ACD061AA	036ACD081AA	036ACD101AA
<b>Cooling Performance<sup>1</sup></b>				<b>CONTINUED</b> →
Gross Cooling Capacity Btu [kW]	29,600 [8.67]	35,400 [10.37]	35,400 [10.37]	35,400 [10.37]
EER/SEER <sup>2</sup>	12/14	11.8/14	11.8/14	11.8/14
Nominal CFM/AHRI Rated CFM [L/s]	1000/1000 [472/472]	1200/1200 [566/566]	1200/1200 [566/566]	1200/1200 [566/566]
AHRI Net Cooling Capacity Btu [kW]	28,400 [8.32]	34,000 [9.96]	34,000 [9.96]	34,000 [9.96]
Net Sensible Capacity Btu [kW]	21,200 [6.21]	24,200 [7.09]	24,200 [7.09]	24,200 [7.09]
Net Latent Capacity Btu [kW]	7,200 [2.11]	9,800 [2.87]	9,800 [2.87]	9,800 [2.87]
Net System Power kW	2.37	2.89	2.89	2.89
<b>Heating Performance (Gas)<sup>3</sup></b>				
Heating Input Btu [kW]	80,000 [23.44]	60,000 [17.58]	80,000 [23.44]	100,000 [29.3]
Heating Output Btu [kW]	65,000 [19.04]	48,000 [14.06]	65,000 [19.04]	81,000 [23.73]
Temperature Rise Range °F [°C]	35-65 [19.4-36.1]	30-60 [16.7-33.3]	30-60 [16.7-33.3]	40-70 [22.2-38.9]
AFUE % <sup>4</sup>	81	81	81	81
Steady State Efficiency (%)	82	82	82	82
No. Burners	3	3	3	3
No. Stages	1	1	1	1
Gas Connection Pipe Size in. [mm]	0.5 [12.7]	0.5 [12.7]	0.5 [12.7]	0.5 [12.7]
<b>Compressor</b>				
No./Type	1/Scroll	1/Scroll	1/Scroll	1/Scroll
<b>Outdoor Sound Rating (dB)<sup>5</sup></b>	76	76	76	76
<b>Outdoor Coil—Fin Type</b>	Louvered	Louvered	Louvered	Louvered
Tube Type	MicroChannel	MicroChannel	MicroChannel	MicroChannel
MicroChannel Depth in. [mm]	0.71 [18]	0.71 [18]	0.71 [18]	0.71 [18]
Face Area sq. ft. [sq. m]	9.9 [0.92]	9.8 [0.91]	9.8 [0.91]	9.8 [0.91]
Rows / FPI [FPcm]	1 / 23 [9]	1 / 23 [9]	1 / 23 [9]	1 / 23 [9]
<b>Indoor Coil—Fin Type</b>	Louvered	Louvered	Louvered	Louvered
Tube Type	MicroChannel	MicroChannel	MicroChannel	MicroChannel
MicroChannel Depth in. [mm]	1 [25.4]	1 [25.4]	1 [25.4]	1 [25.4]
Face Area sq. ft. [sq. m]	3.6 [0.33]	3.6 [0.33]	3.6 [0.33]	3.6 [0.33]
Rows / FPI [FPcm]	1 / 23 [9]	1 / 23 [9]	1 / 23 [9]	1 / 23 [9]
Refrigerant Control	TX Valves	TX Valves	TX Valves	TX Valves
Drain Connection No./Size in. [mm]	1/0.75 [19.05]	1/0.75 [19.05]	1/0.75 [19.05]	1/0.75 [19.05]
<b>Outdoor Fan—Type</b>	Propeller	Propeller	Propeller	Propeller
No. Used/Diameter in. [mm]	1/22 [558.8]	1/22 [558.8]	1/22 [558.8]	1/22 [558.8]
Drive Type/No. Speeds	Direct/1	Direct/1	Direct/1	Direct/1
CFM [L/s]	2500 [1180]	2700 [1274]	2700 [1274]	2700 [1274]
No. Motors/HP	1 at 1/3 HP	1 at 1/3 HP	1 at 1/3 HP	1 at 1/3 HP
Motor RPM	1075	1075	1075	1075
<b>Indoor Fan—Type</b>	FC Centrifugal	FC Centrifugal	FC Centrifugal	FC Centrifugal
No. Used/Diameter in. [mm]	1/10x9 [254x229]	1/12x9 [305x229]	1/12x9 [305x229]	1/12x9 [305x229]
Drive Type	Direct	Direct	Direct	Direct
No. Speeds	Multiple	Multiple	Multiple	Multiple
No. Motors	1	1	1	1
Motor HP	1/2	1/2	1/2	1/2
Motor RPM	1075	1075	1075	1075
Motor Frame Size	48	48	48	48
<b>Filter—Type</b>	Field Supplied	Field Supplied	Field Supplied	Field Supplied
Furnished	No	No	No	No
(NO.) Size Recommended in. [mm x mm x mm]	(1)1x24x24 [25x610x610]	(1)1x24x24 [25x610x610]	(1)1x24x24 [25x610x610]	(1)1x24x24 [25x610x610]
<b>Refrigerant Charge Oz. [g]</b>	46.8 [1327]	52.7 [1494]	52.7 [1494]	52.7 [1494]
<b>Weights</b>				
Net Weight lbs. [kg]	408 [185]	411 [186]	416 [189]	421 [191]
Ship Weight lbs. [kg]	418 [190]	421 [191]	426 [193]	431 [196]

See Page 33 for Notes.

[ ] Designates Metric Conversions

## NOMINAL SIZES 2-5 TONS [7.0-17.6 kW]

Model RGEA14 Series	036ADD061AA	036ADD081AA	036ADD101AA	036AJD061AA
<b>Cooling Performance<sup>1</sup></b>				<b>CONTINUED</b> →
Gross Cooling Capacity Btu [kW]	35,400 [10.37]	35,400 [10.37]	35,400 [10.37]	35,400 [10.37]
EER/SEER <sup>2</sup>	11.8/14	11.8/14	11.8/14	11.8/14
Nominal CFM/AHRI Rated CFM [L/s]	1200/1200 [566/566]	1200/1200 [566/566]	1200/1200 [566/566]	1200/1200 [566/566]
AHRI Net Cooling Capacity Btu [kW]	34,000 [9.96]	34,000 [9.96]	34,000 [9.96]	34,000 [9.96]
Net Sensible Capacity Btu [kW]	24,200 [7.09]	24,200 [7.09]	24,200 [7.09]	24,200 [7.09]
Net Latent Capacity Btu [kW]	9,800 [2.87]	9,800 [2.87]	9,800 [2.87]	9,800 [2.87]
Net System Power kW	2.89	2.89	2.89	2.89
<b>Heating Performance (Gas)<sup>3</sup></b>				
Heating Input Btu [kW]	60,000 [17.58]	80,000 [23.44]	100,000 [29.3]	60,000 [17.58]
Heating Output Btu [kW]	48,000 [14.06]	65,000 [19.04]	81,000 [23.73]	48,000 [14.06]
Temperature Rise Range °F [°C]	30-60 [16.7-33.3]	30-60 [16.7-33.3]	40-70 [22.2-38.9]	30-60 [16.7-33.3]
AFUE % <sup>4</sup>	81	81	81	81
Steady State Efficiency (%)	82	82	82	82
No. Burners	3	3	3	3
No. Stages	1	1	1	1
Gas Connection Pipe Size in. [mm]	0.5 [12.7]	0.5 [12.7]	0.5 [12.7]	0.5 [12.7]
<b>Compressor</b>				
No./Type	1/Scroll	1/Scroll	1/Scroll	1/Scroll
<b>Outdoor Sound Rating (dB)<sup>5</sup></b>	76	76	76	76
<b>Outdoor Coil—Fin Type</b>	Louvered	Louvered	Louvered	Louvered
Tube Type	MicroChannel	MicroChannel	MicroChannel	MicroChannel
MicroChannel Depth in. [mm]	0.71 [18]	0.71 [18]	0.71 [18]	0.71 [18]
Face Area sq. ft. [sq. m]	9.8 [0.91]	9.8 [0.91]	9.8 [0.91]	9.8 [0.91]
Rows / FPI [FPcm]	1 / 23 [9]	1 / 23 [9]	1 / 23 [9]	1 / 23 [9]
<b>Indoor Coil—Fin Type</b>	Louvered	Louvered	Louvered	Louvered
Tube Type	MicroChannel	MicroChannel	MicroChannel	MicroChannel
MicroChannel Depth in. [mm]	1 [25.4]	1 [25.4]	1 [25.4]	1 [25.4]
Face Area sq. ft. [sq. m]	3.6 [0.33]	3.6 [0.33]	3.6 [0.33]	3.6 [0.33]
Rows / FPI [FPcm]	1 / 17 [7]	1 / 17 [7]	1 / 17 [7]	1 / 17 [7]
Refrigerant Control	TX Valves	TX Valves	TX Valves	TX Valves
Drain Connection No./Size in. [mm]	1/0.75 [19.05]	1/0.75 [19.05]	1/0.75 [19.05]	1/0.75 [19.05]
<b>Outdoor Fan—Type</b>	Propeller	Propeller	Propeller	Propeller
No. Used/Diameter in. [mm]	1/22 [558.8]	1/22 [558.8]	1/22 [558.8]	1/22 [558.8]
Drive Type/No. Speeds	Direct/1	Direct/1	Direct/1	Direct/1
CFM [L/s]	2700 [1274]	2700 [1274]	2700 [1274]	2700 [1274]
No. Motors/HP	1 at 1/3 HP	1 at 1/3 HP	1 at 1/3 HP	1 at 1/3 HP
Motor RPM	1075	1075	1075	1075
<b>Indoor Fan—Type</b>	FC Centrifugal	FC Centrifugal	FC Centrifugal	FC Centrifugal
No. Used/Diameter in. [mm]	1/12x9 [305x229]	1/12x9 [305x229]	1/12x9 [305x229]	1/12x9 [305x229]
Drive Type	Direct	Direct	Direct	Direct
No. Speeds	Multiple	Multiple	Multiple	Multiple
No. Motors	1	1	1	1
Motor HP	1/2	1/2	1/2	1/2
Motor RPM	1075	1075	1075	1075
Motor Frame Size	48	48	48	48
<b>Filter—Type</b>	Field Supplied	Field Supplied	Field Supplied	Field Supplied
Furnished	No	No	No	No
(NO.) Size Recommended in. [mm x mm x mm]	(1)1x24x24 [25x610x610]	(1)1x24x24 [25x610x610]	(1)1x24x24 [25x610x610]	(1)1x24x24 [25x610x610]
<b>Refrigerant Charge Oz. [g]</b>	52.7 [1494]	52.7 [1494]	52.7 [1494]	52.7 [1494]
<b>Weights</b>				
Net Weight lbs. [kg]	411 [186]	416 [189]	421 [191]	411 [186]
Ship Weight lbs. [kg]	421 [191]	426 [193]	431 [196]	421 [191]

See Page 33 for Notes.

[ ] Designates Metric Conversions



## NOMINAL SIZES 2-5 TONS [7.0-17.6 kW]

Model RGEA14 Series	036AJD06XAA	036AJD081AA	036AJD08XAA	036AJD101AA
<b>Cooling Performance<sup>1</sup></b>				<b>CONTINUED</b> →
Gross Cooling Capacity Btu [kW]	35,400 [10.37]	35,400 [10.37]	35,400 [10.37]	35,400 [10.37]
EER/SEER <sup>2</sup>	11.8/14	11.8/14	11.8/14	11.8/14
Nominal CFM/AHRI Rated CFM [L/s]	1200/1200 [566/566]	1200/1200 [566/566]	1200/1200 [566/566]	1200/1200 [566/566]
AHRI Net Cooling Capacity Btu [kW]	34,000 [9.96]	34,000 [9.96]	34,000 [9.96]	34,000 [9.96]
Net Sensible Capacity Btu [kW]	24,200 [7.09]	24,200 [7.09]	24,200 [7.09]	24,200 [7.09]
Net Latent Capacity Btu [kW]	9,800 [2.87]	9,800 [2.87]	9,800 [2.87]	9,800 [2.87]
Net System Power kW	2.89	2.89	2.89	2.89
<b>Heating Performance (Gas)<sup>3</sup></b>				
Heating Input Btu [kW]	60,000 [17.58]	80,000 [23.44]	80,000 [23.44]	100,000 [29.3]
Heating Output Btu [kW]	48,000 [14.06]	65,000 [19.04]	65,000 [19.04]	81,000 [23.73]
Temperature Rise Range °F [°C]	30-60 [16.7-33.3]	30-60 [16.7-33.3]	30-60 [16.7-33.3]	40-70 [22.2-38.9]
AFUE % <sup>4</sup>	81	81	81	81
Steady State Efficiency (%)	82	82	82	82
No. Burners	3	3	3	3
No. Stages	1	1	1	1
Gas Connection Pipe Size in. [mm]	0.5 [12.7]	0.5 [12.7]	0.5 [12.7]	0.5 [12.7]
<b>Compressor</b>				
No./Type	1/Scroll	1/Scroll	1/Scroll	1/Scroll
<b>Outdoor Sound Rating (dB)<sup>5</sup></b>	76	76	76	76
<b>Outdoor Coil—Fin Type</b>	Louvered	Louvered	Louvered	Louvered
Tube Type	MicroChannel	MicroChannel	MicroChannel	MicroChannel
MicroChannel Depth in. [mm]	0.71 [18]	0.71 [18]	0.71 [18]	0.71 [18]
Face Area sq. ft. [sq. m]	9.8 [0.91]	9.8 [0.91]	9.8 [0.91]	9.8 [0.91]
Rows / FPI [FPcm]	1 / 23 [9]	1 / 23 [9]	1 / 23 [9]	1 / 23 [9]
<b>Indoor Coil—Fin Type</b>	Louvered	Louvered	Louvered	Louvered
Tube Type	MicroChannel	MicroChannel	MicroChannel	MicroChannel
MicroChannel Depth in. [mm]	1 [25.4]	1 [25.4]	1 [25.4]	1 [25.4]
Face Area sq. ft. [sq. m]	3.6 [0.33]	3.6 [0.33]	3.6 [0.33]	3.6 [0.33]
Rows / FPI [FPcm]	1 / 17 [7]	1 / 17 [7]	1 / 17 [7]	1 / 17 [7]
Refrigerant Control	TX Valves	TX Valves	TX Valves	TX Valves
Drain Connection No./Size in. [mm]	1/0.75 [19.05]	1/0.75 [19.05]	1/0.75 [19.05]	1/0.75 [19.05]
<b>Outdoor Fan—Type</b>	Propeller	Propeller	Propeller	Propeller
No. Used/Diameter in. [mm]	1/22 [558.8]	1/22 [558.8]	1/22 [558.8]	1/22 [558.8]
Drive Type/No. Speeds	Direct/1	Direct/1	Direct/1	Direct/1
CFM [L/s]	2700 [1274]	2700 [1274]	2700 [1274]	2700 [1274]
No. Motors/HP	1 at 1/3 HP	1 at 1/3 HP	1 at 1/3 HP	1 at 1/3 HP
Motor RPM	1075	1075	1075	1075
<b>Indoor Fan—Type</b>	FC Centrifugal	FC Centrifugal	FC Centrifugal	FC Centrifugal
No. Used/Diameter in. [mm]	1/12x9 [305x229]	1/12x9 [305x229]	1/12x9 [305x229]	1/12x9 [305x229]
Drive Type	Direct	Direct	Direct	Direct
No. Speeds	Multiple	Multiple	Multiple	Multiple
No. Motors	1	1	1	1
Motor HP	1/2	1/2	1/2	1/2
Motor RPM	1075	1075	1075	1075
Motor Frame Size	48	48	48	48
<b>Filter—Type</b>	Field Supplied	Field Supplied	Field Supplied	Field Supplied
Furnished	No	No	No	No
(NO.) Size Recommended in. [mm x mm x mm]	(1)1x24x24 [25x610x610]	(1)1x24x24 [25x610x610]	(1)1x24x24 [25x610x610]	(1)1x24x24 [25x610x610]
<b>Refrigerant Charge Oz. [g]</b>	52.7 [1494]	52.7 [1494]	52.7 [1494]	52.7 [1494]
<b>Weights</b>				
Net Weight lbs. [kg]	411 [186]	416 [189]	416 [189]	421 [191]
Ship Weight lbs. [kg]	421 [191]	426 [193]	426 [193]	431 [196]

See Page 33 for Notes.

[ ] Designates Metric Conversions

## NOMINAL SIZES 2-5 TONS [7.0-17.6 kW]

Model RGEA14 Series	036AJD10XAA	042ACT081AA	042ACT101AA	042AJT081AA
<b>Cooling Performance<sup>1</sup></b>				<b>CONTINUED</b> →
Gross Cooling Capacity Btu [kW]	35,400 [10.37]	41,000 [12.01]	41,000 [12.01]	41,000 [12.01]
EER/SEER <sup>2</sup>	11.8/14	12/14	12/14	12/14
Nominal CFM/AHRI Rated CFM [L/s]	1200/1200 [566/566]	1400/1300 [661/613]	1400/1300 [661/613]	1400/1300 [661/613]
AHRI Net Cooling Capacity Btu [kW]	34,000 [9.96]	40,000 [11.72]	40,000 [11.72]	40,000 [11.72]
Net Sensible Capacity Btu [kW]	24,200 [7.09]	29,000 [8.5]	29,000 [8.5]	29,000 [8.5]
Net Latent Capacity Btu [kW]	9,800 [2.87]	11,000 [3.22]	11,000 [3.22]	11,000 [3.22]
Net System Power kW	2.89	3.27	3.27	3.27
<b>Heating Performance (Gas)<sup>3</sup></b>				
Heating Input Btu [kW]	100,000 [29.3]	80,000 [23.44]	100,000 [29.3]	80,000 [23.44]
Heating Output Btu [kW]	81,000 [23.73]	65,000 [19.04]	81,000 [23.73]	65,000 [19.04]
Temperature Rise Range °F [°C]	40-70 [22.2-38.9]	35-65 [19.4-36.1]	45-75 [25-41.7]	35-65 [19.4-36.1]
AFUE % <sup>4</sup>	81	81	81	81
Steady State Efficiency (%)	82	82	82	82
No. Burners	3	4	4	4
No. Stages	1	1	1	1
Gas Connection Pipe Size in. [mm]	0.5 [12.7]	0.5 [12.7]	0.5 [12.7]	0.5 [12.7]
<b>Compressor</b>				
No./Type	1/Scroll	1/Scroll	1/Scroll	1/Scroll
<b>Outdoor Sound Rating (dB)<sup>5</sup></b>	76	76	76	76
<b>Outdoor Coil—Fin Type</b>	Louvered	Louvered	Louvered	Louvered
Tube Type	MicroChannel	MicroChannel	MicroChannel	MicroChannel
MicroChannel Depth in. [mm]	0.71 [18]	0.71 [18]	0.71 [18]	0.71 [18]
Face Area sq. ft. [sq. m]	9.8 [0.91]	14.1 [1.31]	14.1 [1.31]	14.1 [1.31]
Rows / FPI [FPcm]	1 / 23 [9]	1 / 23 [9]	1 / 23 [9]	1 / 23 [9]
<b>Indoor Coil—Fin Type</b>	Louvered	Louvered	Louvered	Louvered
Tube Type	MicroChannel	MicroChannel	MicroChannel	MicroChannel
MicroChannel Depth in. [mm]	1 [25.4]	1 [25.4]	1 [25.4]	1 [25.4]
Face Area sq. ft. [sq. m]	3.6 [0.33]	3.6 [0.33]	3.6 [0.33]	3.6 [0.33]
Rows / FPI [FPcm]	1 / 17 [7]	1 / 17 [7]	1 / 17 [7]	1 / 17 [7]
Refrigerant Control	TX Valves	TX Valves	TX Valves	TX Valves
Drain Connection No./Size in. [mm]	1/0.75 [19.05]	1/0.75 [19.05]	1/0.75 [19.05]	1/0.75 [19.05]
<b>Outdoor Fan—Type</b>	Propeller	Propeller	Propeller	Propeller
No. Used/Diameter in. [mm]	1/22 [558.8]	1/22 [558.8]	1/22 [558.8]	1/22 [558.8]
Drive Type/No. Speeds	Direct/1	Direct/1	Direct/1	Direct/1
CFM [L/s]	2700 [1274]	3500 [1652]	3500 [1652]	3500 [1652]
No. Motors/HP	1 at 1/3 HP	1 at 1/3 HP	1 at 1/3 HP	1 at 1/3 HP
Motor RPM	1075	1075	1075	1075
<b>Indoor Fan—Type</b>	FC Centrifugal	FC Centrifugal	FC Centrifugal	FC Centrifugal
No. Used/Diameter in. [mm]	1/12x9 [305x229]	1/12x9 [305x229]	1/12x9 [305x229]	1/12x9 [305x229]
Drive Type	Direct	Direct	Direct	Direct
No. Speeds	Multiple	Multiple	Multiple	Multiple
No. Motors	1	1	1	1
Motor HP	1/2	3/4	3/4	3/4
Motor RPM	1075	1075	1075	1075
Motor Frame Size	48	48	48	48
<b>Filter—Type</b>	Field Supplied	Field Supplied	Field Supplied	Field Supplied
Furnished	No	No	No	No
(NO.) Size Recommended in. [mm x mm x mm]	(1)1x24x24 [25x610x610]	(1)1x24x24 [25x610x610]	(1)1x24x24 [25x610x610]	(1)1x24x24 [25x610x610]
<b>Refrigerant Charge Oz. [g]</b>	52.7 [1494]	53.6 [1520]	53.6 [1520]	53.6 [1520]
<b>Weights</b>				
Net Weight lbs. [kg]	421 [191]	441 [200]	446 [202]	441 [200]
Ship Weight lbs. [kg]	431 [196]	451 [205]	456 [207]	451 [205]

See Page 33 for Notes.

[ ] Designates Metric Conversions

## NOMINAL SIZES 2-5 TONS [7.0-17.6 kW]

Model RGEA14 Series	042AJT08XAA	042AJT101AA	042AJT10XAA	048ACT081AA
<b>Cooling Performance<sup>1</sup></b>				<b>CONTINUED</b> →
Gross Cooling Capacity Btu [kW]	41,000 [12.01]	41,000 [12.01]	41,000 [12.01]	47,500 [13.92]
EER/SEER <sup>2</sup>	12/14	12/14	12/14	11.7/14
Nominal CFM/AHRI Rated CFM [L/s]	1400/1300 [661/613]	1400/1300 [661/613]	1400/1300 [661/613]	1600/1550 [755/731]
AHRI Net Cooling Capacity Btu [kW]	40,000 [11.72]	40,000 [11.72]	40,000 [11.72]	46,000 [13.48]
Net Sensible Capacity Btu [kW]	29,000 [8.5]	29,000 [8.5]	29,000 [8.5]	32,500 [9.52]
Net Latent Capacity Btu [kW]	11,000 [3.22]	11,000 [3.22]	11,000 [3.22]	13,500 [3.96]
Net System Power kW	3.27	3.27	3.27	3.89
<b>Heating Performance (Gas)<sup>3</sup></b>				
Heating Input Btu [kW]	80,000 [23.44]	100,000 [29.3]	100,000 [29.3]	80,000 [23.44]
Heating Output Btu [kW]	65,000 [19.04]	81,000 [23.73]	81,000 [23.73]	65,000 [19.04]
Temperature Rise Range °F [°C]	35-65 [19.4-36.1]	45-75 [25-41.7]	45-75 [25-41.7]	35-65 [19.4-36.1]
AFUE % <sup>4</sup>	81	81	81	81
Steady State Efficiency (%)	82	82	82	82
No. Burners	4	4	4	4
No. Stages	1	1	1	1
Gas Connection Pipe Size in. [mm]	0.5 [12.7]	0.5 [12.7]	0.5 [12.7]	0.5 [12.7]
<b>Compressor</b>				
No./Type	1/Scroll	1/Scroll	1/Scroll	1/Scroll
<b>Outdoor Sound Rating (dB)<sup>5</sup></b>	76	76	76	78
<b>Outdoor Coil—Fin Type</b>	Louvered	Louvered	Louvered	Louvered
Tube Type	MicroChannel	MicroChannel	MicroChannel	MicroChannel
MicroChannel Depth in. [mm]	0.71 [18]	0.71 [18]	0.71 [18]	0.71 [18]
Face Area sq. ft. [sq. m]	14.1 [1.31]	14.1 [1.31]	14.1 [1.31]	16.3 [1.51]
Rows / FPI [FPcm]	1 / 23 [9]	1 / 23 [9]	1 / 23 [9]	1 / 23 [9]
<b>Indoor Coil—Fin Type</b>	Louvered	Louvered	Louvered	Louvered
Tube Type	MicroChannel	MicroChannel	MicroChannel	MicroChannel
MicroChannel Depth in. [mm]	1 [25.4]	1 [25.4]	1 [25.4]	1 [25.4]
Face Area sq. ft. [sq. m]	3.6 [0.33]	3.6 [0.33]	3.6 [0.33]	4.1 [0.38]
Rows / FPI [FPcm]	1 / 17 [7]	1 / 17 [7]	1 / 17 [7]	1 / 20 [8]
Refrigerant Control	TX Valves	TX Valves	TX Valves	TX Valves
Drain Connection No./Size in. [mm]	1/0.75 [19.05]	1/0.75 [19.05]	1/0.75 [19.05]	1/0.75 [19.05]
<b>Outdoor Fan—Type</b>	Propeller	Propeller	Propeller	Propeller
No. Used/Diameter in. [mm]	1/22 [558.8]	1/22 [558.8]	1/22 [558.8]	1/22 [558.8]
Drive Type/No. Speeds	Direct/1	Direct/1	Direct/1	Direct/1
CFM [L/s]	3500 [1652]	3500 [1652]	3500 [1652]	3300 [1557]
No. Motors/HP	1 at 1/3 HP	1 at 1/3 HP	1 at 1/3 HP	1 at 1/3 HP
Motor RPM	1075	1075	1075	1075
<b>Indoor Fan—Type</b>	FC Centrifugal	FC Centrifugal	FC Centrifugal	FC Centrifugal
No. Used/Diameter in. [mm]	1/12x9 [305x229]	1/12x9 [305x229]	1/12x9 [305x229]	1/12x9 [305x229]
Drive Type	Direct	Direct	Direct	Direct
No. Speeds	Multiple	Multiple	Multiple	Multiple
No. Motors	1	1	1	1
Motor HP	3/4	3/4	3/4	3/4
Motor RPM	1075	1075	1075	1075
Motor Frame Size	48	48	48	48
<b>Filter—Type</b>	Field Supplied	Field Supplied	Field Supplied	Field Supplied
Furnished	No	No	No	No
(NO.) Size Recommended in. [mm x mm x mm]	(1)1x24x24 [25x610x610]	(1)1x24x24 [25x610x610]	(1)1x24x24 [25x610x610]	(1)1x24x24 [25x610x610]
<b>Refrigerant Charge Oz. [g]</b>	53.6 [1520]	53.6 [1520]	53.6 [1520]	69.3 [1965]
<b>Weights</b>				
Net Weight lbs. [kg]	441 [200]	446 [202]	446 [202]	477 [216]
Ship Weight lbs. [kg]	451 [205]	456 [207]	456 [207]	487 [221]

See Page 33 for Notes.

[ ] Designates Metric Conversions

## NOMINAL SIZES 2-5 TONS [7.0-17.6 kW]

Model RGEA14 Series	048ACT101AA	048ADT101AA	048AJT081AA	048AJT08XAA
<b>Cooling Performance<sup>1</sup></b>				<b>CONTINUED</b> →
Gross Cooling Capacity Btu [kW]	47,500 [13.92]	47,500 [13.92]	47,500 [13.92]	47,500 [13.92]
EER/SEER <sup>2</sup>	11.7/14	11.7/14	11.7/14	11.7/14
Nominal CFM/AHRI Rated CFM [L/s]	1600/1550 [755/731]	1600/1550 [755/731]	1600/1550 [755/731]	1600/1550 [755/731]
AHRI Net Cooling Capacity Btu [kW]	46,000 [13.48]	46,000 [13.48]	46,000 [13.48]	46,000 [13.48]
Net Sensible Capacity Btu [kW]	32,500 [9.52]	32,500 [9.52]	32,500 [9.52]	32,500 [9.52]
Net Latent Capacity Btu [kW]	13,500 [3.96]	13,500 [3.96]	13,500 [3.96]	13,500 [3.96]
Net System Power kW	3.89	3.89	3.89	3.89
<b>Heating Performance (Gas)<sup>3</sup></b>				
Heating Input Btu [kW]	100,000 [29.3]	100,000 [29.3]	80,000 [23.44]	80,000 [23.44]
Heating Output Btu [kW]	81,000 [23.73]	81,000 [23.73]	65,000 [19.04]	65,000 [19.04]
Temperature Rise Range °F [°C]	45-75 [25-41.7]	45-75 [25-41.7]	35-65 [19.4-36.1]	35-65 [19.4-36.1]
AFUE % <sup>4</sup>	81	81	81	81
Steady State Efficiency (%)	82	82	82	82
No. Burners	4	4	4	4
No. Stages	1	1	1	1
Gas Connection Pipe Size in. [mm]	0.5 [12.7]	0.5 [12.7]	0.5 [12.7]	0.5 [12.7]
<b>Compressor</b>				
No./Type	1/Scroll	1/Scroll	1/Scroll	1/Scroll
<b>Outdoor Sound Rating (dB)<sup>5</sup></b>	78	78	78	78
<b>Outdoor Coil—Fin Type</b>	Louvered	Louvered	Louvered	Louvered
Tube Type	MicroChannel	MicroChannel	MicroChannel	MicroChannel
MicroChannel Depth in. [mm]	0.71 [18]	0.71 [18]	0.71 [18]	0.71 [18]
Face Area sq. ft. [sq. m]	16.3 [1.51]	16.3 [1.51]	16.3 [1.51]	16.3 [1.51]
Rows / FPI [FPcm]	1 / 23 [9]	1 / 23 [9]	1 / 23 [9]	1 / 23 [9]
<b>Indoor Coil—Fin Type</b>	Louvered	Louvered	Louvered	Louvered
Tube Type	MicroChannel	MicroChannel	MicroChannel	MicroChannel
MicroChannel Depth in. [mm]	1 [25.4]	1 [25.4]	1 [25.4]	1 [25.4]
Face Area sq. ft. [sq. m]	4.1 [0.38]	4.1 [0.38]	4.1 [0.38]	4.1 [0.38]
Rows / FPI [FPcm]	1 / 20 [8]	1 / 20 [8]	1 / 20 [8]	1 / 20 [8]
Refrigerant Control	TX Valves	TX Valves	TX Valves	TX Valves
Drain Connection No./Size in. [mm]	1/0.75 [19.05]	1/0.75 [19.05]	1/0.75 [19.05]	1/0.75 [19.05]
<b>Outdoor Fan—Type</b>	Propeller	Propeller	Propeller	Propeller
No. Used/Diameter in. [mm]	1/22 [558.8]	1/22 [558.8]	1/22 [558.8]	1/22 [558.8]
Drive Type/No. Speeds	Direct/1	Direct/1	Direct/1	Direct/1
CFM [L/s]	3300 [1557]	3300 [1557]	3300 [1557]	3300 [1557]
No. Motors/HP	1 at 1/3 HP	1 at 1/3 HP	1 at 1/3 HP	1 at 1/3 HP
Motor RPM	1075	1075	1075	1075
<b>Indoor Fan—Type</b>	FC Centrifugal	FC Centrifugal	FC Centrifugal	FC Centrifugal
No. Used/Diameter in. [mm]	1/12x9 [305x229]	1/12x9 [305x229]	1/12x9 [305x229]	1/12x9 [305x229]
Drive Type	Direct	Direct	Direct	Direct
No. Speeds	Multiple	Multiple	Multiple	Multiple
No. Motors	1	1	1	1
Motor HP	3/4	3/4	3/4	3/4
Motor RPM	1075	1075	1075	1075
Motor Frame Size	48	48	48	48
<b>Filter—Type</b>	Field Supplied	Field Supplied	Field Supplied	Field Supplied
Furnished	No	No	No	No
(NO.) Size Recommended in. [mm x mm x mm]	(1)1x24x24 [25x610x610]	(1)1x24x24 [25x610x610]	(1)1x24x24 [25x610x610]	(1)1x24x24 [25x610x610]
<b>Refrigerant Charge Oz. [g]</b>	69.3 [1965]	69.3 [1965]	69.3 [1965]	69.3 [1965]
<b>Weights</b>				
Net Weight lbs. [kg]	482 [219]	482 [219]	477 [216]	477 [216]
Ship Weight lbs. [kg]	492 [223]	492 [223]	487 [221]	487 [221]

See Page 33 for Notes.

[ ] Designates Metric Conversions

## NOMINAL SIZES 2-5 TONS [7.0-17.6 kW]

Model RGEA14 Series	048AJT101AA	048AJT10XAA	060ACT101AA	060ADT101AA
<b>Cooling Performance<sup>1</sup></b>				<b>CONTINUED</b> →
Gross Cooling Capacity Btu [kW]	47,500 [13.92]	47,500 [13.92]	59,000 [17.29]	59,000 [17.29]
EER/SEER <sup>2</sup>	11.7/14	11.7/14	11.6/14	11.6/14
Nominal CFM/AHRI Rated CFM [L/s]	1600/1550 [755/731]	1600/1550 [755/731]	2000/1700 [944/802]	2000/1700 [944/802]
AHRI Net Cooling Capacity Btu [kW]	46,000 [13.48]	46,000 [13.48]	57,000 [16.7]	57,000 [16.7]
Net Sensible Capacity Btu [kW]	32,500 [9.52]	32,500 [9.52]	39,500 [11.57]	39,500 [11.57]
Net Latent Capacity Btu [kW]	13,500 [3.96]	13,500 [3.96]	17,500 [5.13]	17,500 [5.13]
Net System Power kW	3.89	3.89	4.94	4.94
<b>Heating Performance (Gas)<sup>3</sup></b>				
Heating Input Btu [kW]	100,000 [29.3]	100,000 [29.3]	100,000 [29.3]	100,000 [29.3]
Heating Output Btu [kW]	81,000 [23.73]	81,000 [23.73]	81,000 [23.73]	81,000 [23.73]
Temperature Rise Range °F [°C]	45-75 [25-41.7]	45-75 [25-41.7]	45-75 [25-41.7]	45-75 [25-41.7]
AFUE % <sup>4</sup>	81	81	81	81
Steady State Efficiency (%)	82	82	82	82
No. Burners	4	4	5	5
No. Stages	1	1	1	1
Gas Connection Pipe Size in. [mm]	0.5 [12.7]	0.5 [12.7]	0.5 [12.7]	0.5 [12.7]
<b>Compressor</b>				
No./Type	1/Scroll	1/Scroll	1/Scroll	1/Scroll
<b>Outdoor Sound Rating (dB)<sup>5</sup></b>	78	78	79	79
<b>Outdoor Coil—Fin Type</b>	Louvered	Louvered	Louvered	Louvered
Tube Type	MicroChannel	MicroChannel	MicroChannel	MicroChannel
MicroChannel Depth in. [mm]	0.71 [18]	0.71 [18]	1 [25.4]	1 [25.4]
Face Area sq. ft. [sq. m]	16.3 [1.51]	16.3 [1.51]	15.3 [1.42]	15.3 [1.42]
Rows / FPI [FPcm]	1 / 23 [9]	1 / 23 [9]	1 / 23 [9]	1 / 23 [9]
<b>Indoor Coil—Fin Type</b>	Louvered	Louvered	Louvered	Louvered
Tube Type	MicroChannel	MicroChannel	MicroChannel	MicroChannel
MicroChannel Depth in. [mm]	1 [25.4]	1 [25.4]	1.26 [32]	1.26 [32]
Face Area sq. ft. [sq. m]	4.1 [0.38]	4.1 [0.38]	4 [0.37]	4 [0.37]
Rows / FPI [FPcm]	1 / 20 [8]	1 / 20 [8]	1 / 20 [8]	1 / 20 [8]
Refrigerant Control	TX Valves	TX Valves	TX Valves	TX Valves
Drain Connection No./Size in. [mm]	1/0.75 [19.05]	1/0.75 [19.05]	1/0.75 [19.05]	1/0.75 [19.05]
<b>Outdoor Fan—Type</b>	Propeller	Propeller	Propeller	Propeller
No. Used/Diameter in. [mm]	1/22 [558.8]	1/22 [558.8]	1/22 [558.8]	1/22 [558.8]
Drive Type/No. Speeds	Direct/1	Direct/1	Direct/1	Direct/1
CFM [L/s]	3300 [1557]	3300 [1557]	3400 [1604]	3400 [1604]
No. Motors/HP	1 at 1/3 HP	1 at 1/3 HP	1 at 1/3 HP	1 at 1/3 HP
Motor RPM	1075	1075	1075	1075
<b>Indoor Fan—Type</b>	FC Centrifugal	FC Centrifugal	FC Centrifugal	FC Centrifugal
No. Used/Diameter in. [mm]	1/12x9 [305x229]	1/12x9 [305x229]	1/12x9 [305x229]	1/12x9 [305x229]
Drive Type	Direct	Direct	Direct	Direct
No. Speeds	Multiple	Multiple	Multiple	Multiple
No. Motors	1	1	1	1
Motor HP	3/4	3/4	1	1
Motor RPM	1075	1075	1075	1075
Motor Frame Size	48	48	48	48
<b>Filter—Type</b>	Field Supplied	Field Supplied	Field Supplied	Field Supplied
Furnished	No	No	No	No
(NO.) Size Recommended in. [mm x mm x mm]	(1)1x24x24 [25x610x610]	(1)1x24x24 [25x610x610]	(1)1x24x30 [25x610x762]	(1)1x24x30 [25x610x762]
<b>Refrigerant Charge Oz. [g]</b>	69.3 [1965]	69.3 [1965]	83.1 [2356]	83.1 [2356]
<b>Weights</b>				
Net Weight lbs. [kg]	482 [219]	482 [219]	512 [232]	512 [232]
Ship Weight lbs. [kg]	492 [223]	492 [223]	522 [237]	522 [237]

See Page 33 for Notes.

[ ] Designates Metric Conversions



## NOMINAL SIZES 2-5 TONS [7.0-17.6 kW]

Model RGEA14 Series	060AJT101AA	060AJT10XAA
<b>Cooling Performance<sup>1</sup></b>		
Gross Cooling Capacity Btu [kW]	59,000 [17.29]	59,000 [17.29]
EER/SEER <sup>2</sup>	11.6/14	11.6/14
Nominal CFM/AHRI Rated CFM [L/s]	2000/1700 [944/802]	2000/1700 [944/802]
AHRI Net Cooling Capacity Btu [kW]	57,000 [16.7]	57,000 [16.7]
Net Sensible Capacity Btu [kW]	39,500 [11.57]	39,500 [11.57]
Net Latent Capacity Btu [kW]	17,500 [5.13]	17,500 [5.13]
Net System Power kW	4.94	4.94
<b>Heating Performance (Gas)<sup>3</sup></b>		
Heating Input Btu [kW]	100,000 [29.3]	100,000 [29.3]
Heating Output Btu [kW]	81,000 [23.73]	81,000 [23.73]
Temperature Rise Range °F [°C]	45-75 [25-41.7]	45-75 [25-41.7]
AFUE % <sup>4</sup>	81	81
Steady State Efficiency (%)	82	82
No. Burners	5	5
No. Stages	1	1
Gas Connection Pipe Size in. [mm]	0.5 [12.7]	0.5 [12.7]
<b>Compressor</b>		
No./Type	1/Scroll	1/Scroll
<b>Outdoor Sound Rating (dB)<sup>5</sup></b>		
	79	79
<b>Outdoor Coil—Fin Type</b>		
Tube Type	Louvered	Louvered
MicroChannel Depth in. [mm]	MicroChannel	MicroChannel
Face Area sq. ft. [sq. m]	1 [25.4]	1 [25.4]
Rows / FPI [FPcm]	15.3 [1.42]	15.3 [1.42]
	1 / 23 [9]	1 / 23 [9]
<b>Indoor Coil—Fin Type</b>		
Tube Type	Louvered	Louvered
MicroChannel Depth in. [mm]	MicroChannel	MicroChannel
Face Area sq. ft. [sq. m]	1.26 [32]	1.26 [32]
Rows / FPI [FPcm]	4 [0.37]	4 [0.37]
Refrigerant Control	1 / 20 [8]	1 / 20 [8]
Drain Connection No./Size in. [mm]	TX Valves	TX Valves
	1/0.75 [19.05]	1/0.75 [19.05]
<b>Outdoor Fan—Type</b>		
No. Used/Diameter in. [mm]	Propeller	Propeller
Drive Type/No. Speeds	1/22 [558.8]	1/22 [558.8]
CFM [L/s]	Direct/1	Direct/1
No. Motors/HP	3400 [1604]	3400 [1604]
Motor RPM	1 at 1/3 HP	1 at 1/3 HP
	1075	1075
<b>Indoor Fan—Type</b>		
No. Used/Diameter in. [mm]	FC Centrifugal	FC Centrifugal
Drive Type	1/12x9 [305x229]	1/12x9 [305x229]
No. Speeds	Direct	Direct
No. Motors	Multiple	Multiple
Motor HP	1	1
Motor RPM	1	1
Motor Frame Size	1075	1075
	48	48
<b>Filter—Type</b>		
Furnished	Field Supplied	Field Supplied
(NO.) Size Recommended in. [mm x mm x mm]	No	No
	(1)1x24x30 [25x610x762]	(1)1x24x30 [25x610x762]
<b>Refrigerant Charge Oz. [g]</b>		
	83.1 [2356]	83.1 [2356]
<b>Weights</b>		
Net Weight lbs. [kg]	512 [232]	512 [232]
Ship Weight lbs. [kg]	522 [237]	522 [237]

See Page 33 for Notes.

[ ] Designates Metric Conversions



## NOMINAL SIZES 2-5 TONS [7.0-17.6 kW]

Model RGEA15 Series	024AJT061AA	024AJT06XAA	024AJT081AA	024AJT08XAA
<b>Cooling Performance<sup>1</sup></b>				<b>CONTINUED</b> →
Gross Cooling Capacity Btu [kW]	24,600 [7.21]	24,600 [7.21]	24,600 [7.21]	24,600 [7.21]
EER/SEER <sup>2</sup>	12/15	12/15	12/15	12/15
Nominal CFM/AHRI Rated CFM [L/s]	800/900 [378/425]	800/900 [378/425]	800/900 [378/425]	800/900 [378/425]
AHRI Net Cooling Capacity Btu [kW]	24,000 [7.03]	24,000 [7.03]	24,000 [7.03]	24,000 [7.03]
Net Sensible Capacity Btu [kW]	18,100 [5.3]	18,100 [5.3]	18,100 [5.3]	18,100 [5.3]
Net Latent Capacity Btu [kW]	5,900 [1.73]	5,900 [1.73]	5,900 [1.73]	5,900 [1.73]
Net System Power kW	2.03	2.03	2.03	2.03
<b>Heating Performance (Gas)<sup>3</sup></b>				
Heating Input Btu [kW]	60,000 [17.58]	60,000 [17.58]	80,000 [23.44]	80,000 [23.44]
Heating Output Btu [kW]	48,000 [14.06]	48,000 [14.06]	65,000 [19.04]	65,000 [19.04]
Temperature Rise Range °F [°C]	40-70 [22.2-38.9]	40-70 [22.2-38.9]	35-65 [19.4-36.1]	35-65 [19.4-36.1]
AFUE % <sup>4</sup>	81	81	81	81
Steady State Efficiency (%)	82	82	82	82
No. Burners	2	2	2	2
No. Stages	1	1	1	1
Gas Connection Pipe Size in. [mm]	0.5 [12.7]	0.5 [12.7]	0.5 [12.7]	0.5 [12.7]
<b>Compressor</b>				
No./Type	1/Scroll	1/Scroll	1/Scroll	1/Scroll
<b>Outdoor Sound Rating (dB)<sup>5</sup></b>	76	76	76	76
<b>Outdoor Coil—Fin Type</b>	Louvered	Louvered	Louvered	Louvered
Tube Type	MicroChannel	MicroChannel	MicroChannel	MicroChannel
MicroChannel Depth in. [mm]	0.71 [18]	0.71 [18]	0.71 [18]	0.71 [18]
Face Area sq. ft. [sq. m]	7.1 [0.66]	7.1 [0.66]	7.1 [0.66]	7.1 [0.66]
Rows / FPI [FPcm]	1 / 23 [9]	1 / 23 [9]	1 / 23 [9]	1 / 23 [9]
<b>Indoor Coil—Fin Type</b>	Louvered	Louvered	Louvered	Louvered
Tube Type	MicroChannel	MicroChannel	MicroChannel	MicroChannel
MicroChannel Depth in. [mm]	1 [25.4]	1 [25.4]	1 [25.4]	1 [25.4]
Face Area sq. ft. [sq. m]	3.6 [0.33]	3.6 [0.33]	3.6 [0.33]	3.6 [0.33]
Rows / FPI [FPcm]	1 / 17 [7]	1 / 17 [7]	1 / 17 [7]	1 / 17 [7]
Refrigerant Control	TX Valves	TX Valves	TX Valves	TX Valves
Drain Connection No./Size in. [mm]	1/0.75 [19.05]	1/0.75 [19.05]	1/0.75 [19.05]	1/0.75 [19.05]
<b>Outdoor Fan—Type</b>	Propeller	Propeller	Propeller	Propeller
No. Used/Diameter in. [mm]	1/22 [558.8]	1/22 [558.8]	1/22 [558.8]	1/22 [558.8]
Drive Type/No. Speeds	Direct/1	Direct/1	Direct/1	Direct/1
CFM [L/s]	2500 [1180]	2500 [1180]	2500 [1180]	2500 [1180]
No. Motors/HP	1 at 1/3 HP	1 at 1/3 HP	1 at 1/3 HP	1 at 1/3 HP
Motor RPM	1075	1075	1075	1075
<b>Indoor Fan—Type</b>	FC Centrifugal	FC Centrifugal	FC Centrifugal	FC Centrifugal
No. Used/Diameter in. [mm]	1/12x7 [305x178]	1/12x7 [305x178]	1/12x7 [305x178]	1/12x7 [305x178]
Drive Type	Direct	Direct	Direct	Direct
No. Speeds	Multiple	Multiple	Multiple	Multiple
No. Motors	1	1	1	1
Motor HP	1/3	1/3	1/3	1/3
Motor RPM	1075	1075	1075	1075
Motor Frame Size	48	48	48	48
<b>Filter—Type</b>	Field Supplied	Field Supplied	Field Supplied	Field Supplied
Furnished	No	No	No	No
(NO.) Size Recommended in. [mm x mm x mm]	(1)1x20x20 [25x508x508]	(1)1x20x20 [25x508x508]	(1)1x20x20 [25x508x508]	(1)1x20x20 [25x508x508]
<b>Refrigerant Charge Oz. [g]</b>	42.6 [1208]	42.6 [1208]	42.6 [1208]	42.6 [1208]
<b>Weights</b>				
Net Weight lbs. [kg]	403 [183]	403 [183]	408 [185]	408 [185]
Ship Weight lbs. [kg]	413 [187]	413 [187]	418 [190]	418 [190]

See Page 33 for Notes.

[ ] Designates Metric Conversions

## NOMINAL SIZES 2-5 TONS [7.0-17.6 kW]

Model RGEA15 Series	024AJV061AA	024AJV06XAA	024AJV081AA	024AJV08XAA
<b>Cooling Performance<sup>1</sup></b>				<b>CONTINUED</b> →
Gross Cooling Capacity Btu [kW]	24,600 [7.21]	24,600 [7.21]	24,600 [7.21]	24,600 [7.21]
EER/SEER <sup>2</sup>	12/15	12/15	12/15	12/15
Nominal CFM/AHRI Rated CFM [L/s]	800/900 [378/425]	800/900 [378/425]	800/900 [378/425]	800/900 [378/425]
AHRI Net Cooling Capacity Btu [kW]	24,000 [7.03]	24,000 [7.03]	24,000 [7.03]	24,000 [7.03]
Net Sensible Capacity Btu [kW]	18,100 [5.3]	18,100 [5.3]	18,100 [5.3]	18,100 [5.3]
Net Latent Capacity Btu [kW]	5,900 [1.73]	5,900 [1.73]	5,900 [1.73]	5,900 [1.73]
Net System Power kW	2.03	2.03	2.03	2.03
<b>Heating Performance (Gas)<sup>3</sup></b>				
Heating Input Btu [kW]	60,000 [17.58]	60,000 [17.58]	80,000 [23.44]	80,000 [23.44]
Heating Output Btu [kW]	48,000 [14.06]	48,000 [14.06]	65,000 [19.04]	65,000 [19.04]
Temperature Rise Range °F [°C]	40-70 [22.2-38.9]	40-70 [22.2-38.9]	35-65 [19.4-36.1]	35-65 [19.4-36.1]
AFUE % <sup>4</sup>	81	81	81	81
Steady State Efficiency (%)	82	82	82	82
No. Burners	2	2	2	2
No. Stages	1	1	1	1
Gas Connection Pipe Size in. [mm]	0.5 [12.7]	0.5 [12.7]	0.5 [12.7]	0.5 [12.7]
<b>Compressor</b>				
No./Type	1/Scroll	1/Scroll	1/Scroll	1/Scroll
<b>Outdoor Sound Rating (dB)<sup>5</sup></b>	76	76	76	76
<b>Outdoor Coil—Fin Type</b>	Louvered	Louvered	Louvered	Louvered
Tube Type	MicroChannel	MicroChannel	MicroChannel	MicroChannel
MicroChannel Depth in. [mm]	0.71 [18]	0.71 [18]	0.71 [18]	0.71 [18]
Face Area sq. ft. [sq. m]	7.1 [0.66]	7.1 [0.66]	7.1 [0.66]	7.1 [0.66]
Rows / FPI [FPcm]	1 / 23 [9]	1 / 23 [9]	1 / 23 [9]	1 / 23 [9]
<b>Indoor Coil—Fin Type</b>	Louvered	Louvered	Louvered	Louvered
Tube Type	MicroChannel	MicroChannel	MicroChannel	MicroChannel
MicroChannel Depth in. [mm]	1 [25.4]	1 [25.4]	1 [25.4]	1 [25.4]
Face Area sq. ft. [sq. m]	3.6 [0.33]	3.6 [0.33]	3.6 [0.33]	3.6 [0.33]
Rows / FPI [FPcm]	1 / 17 [7]	1 / 17 [7]	1 / 17 [7]	1 / 17 [7]
Refrigerant Control	TX Valves	TX Valves	TX Valves	TX Valves
Drain Connection No./Size in. [mm]	1/0.75 [19.05]	1/0.75 [19.05]	1/0.75 [19.05]	1/0.75 [19.05]
<b>Outdoor Fan—Type</b>	Propeller	Propeller	Propeller	Propeller
No. Used/Diameter in. [mm]	1/22 [558.8]	1/22 [558.8]	1/22 [558.8]	1/22 [558.8]
Drive Type/No. Speeds	Direct/1	Direct/1	Direct/1	Direct/1
CFM [L/s]	2500 [1180]	2500 [1180]	2500 [1180]	2500 [1180]
No. Motors/HP	1 at 1/3 HP	1 at 1/3 HP	1 at 1/3 HP	1 at 1/3 HP
Motor RPM	1075	1075	1075	1075
<b>Indoor Fan—Type</b>	FC Centrifugal	FC Centrifugal	FC Centrifugal	FC Centrifugal
No. Used/Diameter in. [mm]	1/10x9 [254x229]	1/10x9 [254x229]	1/10x9 [254x229]	1/10x9 [254x229]
Drive Type	Direct	Direct	Direct	Direct
No. Speeds	Multiple	Multiple	Multiple	Multiple
No. Motors	1	1	1	1
Motor HP	1/2	1/2	1/2	1/2
Motor RPM	1050	1050	1050	1050
Motor Frame Size	48	48	48	48
<b>Filter—Type</b>	Field Supplied	Field Supplied	Field Supplied	Field Supplied
Furnished	No	No	No	No
(NO.) Size Recommended in. [mm x mm x mm]	(1)1x20x20 [25x508x508]	(1)1x20x20 [25x508x508]	(1)1x20x20 [25x508x508]	(1)1x20x20 [25x508x508]
<b>Refrigerant Charge Oz. [g]</b>	42.6 [1208]	42.6 [1208]	42.6 [1208]	42.6 [1208]
<b>Weights</b>				
Net Weight lbs. [kg]	403 [183]	403 [183]	408 [185]	408 [185]
Ship Weight lbs. [kg]	413 [187]	413 [187]	418 [190]	418 [190]

See Page 33 for Notes.

[ ] Designates Metric Conversions

## NOMINAL SIZES 2-5 TONS [7.0-17.6 kW]

Model RGEA15 Series	030AJT061AA	030AJT06XAA	030AJT081AA	030AJT08XAA
<b>Cooling Performance<sup>1</sup></b>				<b>CONTINUED</b> →
Gross Cooling Capacity Btu [kW]	29,600 [8.67]	29,600 [8.67]	29,600 [8.67]	29,600 [8.67]
EER/SEER <sup>2</sup>	12/15	12/15	12/15	12/15
Nominal CFM/AHRI Rated CFM [L/s]	1000/975 [472/460]	1000/975 [472/460]	1000/975 [472/460]	1000/975 [472/460]
AHRI Net Cooling Capacity Btu [kW]	29,000 [8.5]	29,000 [8.5]	29,000 [8.5]	29,000 [8.5]
Net Sensible Capacity Btu [kW]	21,500 [6.3]	21,500 [6.3]	21,500 [6.3]	21,500 [6.3]
Net Latent Capacity Btu [kW]	7,500 [2.2]	7,500 [2.2]	7,500 [2.2]	7,500 [2.2]
Net System Power kW	2.21	2.21	2.21	2.21
<b>Heating Performance (Gas)<sup>3</sup></b>				
Heating Input Btu [kW]	60,000 [17.58]	60,000 [17.58]	80,000 [23.44]	80,000 [23.44]
Heating Output Btu [kW]	48,000 [14.06]	48,000 [14.06]	65,000 [19.04]	65,000 [19.04]
Temperature Rise Range °F [°C]	40-70 [22.2-38.9]	40-70 [22.2-38.9]	35-65 [19.4-36.1]	35-65 [19.4-36.1]
AFUE % <sup>4</sup>	81	81	81	81
Steady State Efficiency (%)	82	82	82	82
No. Burners	3	3	3	3
No. Stages	1	1	1	1
Gas Connection Pipe Size in. [mm]	0.5 [12.7]	0.5 [12.7]	0.5 [12.7]	0.5 [12.7]
<b>Compressor</b>				
No./Type	1/Scroll	1/Scroll	1/Scroll	1/Scroll
<b>Outdoor Sound Rating (dB)<sup>5</sup></b>	76	76	76	76
<b>Outdoor Coil—Fin Type</b>	Louvered	Louvered	Louvered	Louvered
Tube Type	MicroChannel	MicroChannel	MicroChannel	MicroChannel
MicroChannel Depth in. [mm]	0.71 [18]	0.71 [18]	0.71 [18]	0.71 [18]
Face Area sq. ft. [sq. m]	9.9 [0.92]	9.9 [0.92]	9.9 [0.92]	9.9 [0.92]
Rows / FPI [FPcm]	1 / 23 [9]	1 / 23 [9]	1 / 23 [9]	1 / 23 [9]
<b>Indoor Coil—Fin Type</b>	Louvered	Louvered	Louvered	Louvered
Tube Type	MicroChannel	MicroChannel	MicroChannel	MicroChannel
MicroChannel Depth in. [mm]	1 [25.4]	1 [25.4]	1 [25.4]	1 [25.4]
Face Area sq. ft. [sq. m]	3.6 [0.33]	3.6 [0.33]	3.6 [0.33]	3.6 [0.33]
Rows / FPI [FPcm]	1 / 17 [7]	1 / 17 [7]	1 / 17 [7]	1 / 17 [7]
Refrigerant Control	TX Valves	TX Valves	TX Valves	TX Valves
Drain Connection No./Size in. [mm]	1/0.75 [19.05]	1/0.75 [19.05]	1/0.75 [19.05]	1/0.75 [19.05]
<b>Outdoor Fan—Type</b>	Propeller	Propeller	Propeller	Propeller
No. Used/Diameter in. [mm]	1/22 [558.8]	1/22 [558.8]	1/22 [558.8]	1/22 [558.8]
Drive Type/No. Speeds	Direct/1	Direct/1	Direct/1	Direct/1
CFM [L/s]	2500 [1180]	2500 [1180]	2500 [1180]	2500 [1180]
No. Motors/HP	1 at 1/3 HP	1 at 1/3 HP	1 at 1/3 HP	1 at 1/3 HP
Motor RPM	1075	1075	1075	1075
<b>Indoor Fan—Type</b>	FC Centrifugal	FC Centrifugal	FC Centrifugal	FC Centrifugal
No. Used/Diameter in. [mm]	1/10x9 [254x229]	1/10x9 [254x229]	1/10x9 [254x229]	1/10x9 [254x229]
Drive Type	Direct	Direct	Direct	Direct
No. Speeds	Multiple	Multiple	Multiple	Multiple
No. Motors	1	1	1	1
Motor HP	1/2	1/2	1/2	1/2
Motor RPM	1075	1075	1075	1075
Motor Frame Size	48	48	48	48
<b>Filter—Type</b>	Field Supplied	Field Supplied	Field Supplied	Field Supplied
Furnished	No	No	No	No
(NO.) Size Recommended in. [mm x mm x mm]	(1)1x24x24 [25x610x610]	(1)1x24x24 [25x610x610]	(1)1x24x24 [25x610x610]	(1)1x24x24 [25x610x610]
<b>Refrigerant Charge Oz. [g]</b>	46.8 [1327]	46.8 [1327]	46.8 [1327]	46.8 [1327]
<b>Weights</b>				
Net Weight lbs. [kg]	403 [183]	403 [183]	408 [185]	408 [185]
Ship Weight lbs. [kg]	413 [187]	413 [187]	418 [190]	418 [190]

See Page 33 for Notes.

[ ] Designates Metric Conversions

## NOMINAL SIZES 2-5 TONS [7.0-17.6 kW]

Model RGEA15 Series	030AJV061AA	030AJV06XAA	030AJV081AA	030AJV08XAA
<b>Cooling Performance<sup>1</sup></b>				<b>CONTINUED</b> →
Gross Cooling Capacity Btu [kW]	29,600 [8.67]	29,600 [8.67]	29,600 [8.67]	29,600 [8.67]
EER/SEER <sup>2</sup>	12/15	12/15	12/15	12/15
Nominal CFM/AHRI Rated CFM [L/s]	1000/975 [472/460]	1000/975 [472/460]	1000/975 [472/460]	1000/975 [472/460]
AHRI Net Cooling Capacity Btu [kW]	29,000 [8.5]	29,000 [8.5]	29,000 [8.5]	29,000 [8.5]
Net Sensible Capacity Btu [kW]	21,500 [6.3]	21,500 [6.3]	21,500 [6.3]	21,500 [6.3]
Net Latent Capacity Btu [kW]	7,500 [2.2]	7,500 [2.2]	7,500 [2.2]	7,500 [2.2]
Net System Power kW	2.21	2.21	2.21	2.21
<b>Heating Performance (Gas)<sup>3</sup></b>				
Heating Input Btu [kW]	60,000 [17.58]	60,000 [17.58]	80,000 [23.44]	80,000 [23.44]
Heating Output Btu [kW]	48,000 [14.06]	48,000 [14.06]	65,000 [19.04]	65,000 [19.04]
Temperature Rise Range °F [°C]	40-70 [22.2-38.9]	40-70 [22.2-38.9]	35-65 [19.4-36.1]	35-65 [19.4-36.1]
AFUE % <sup>4</sup>	81	81	81	81
Steady State Efficiency (%)	82	82	82	82
No. Burners	3	3	3	3
No. Stages	1	1	1	1
Gas Connection Pipe Size in. [mm]	0.5 [12.7]	0.5 [12.7]	0.5 [12.7]	0.5 [12.7]
<b>Compressor</b>				
No./Type	1/Scroll	1/Scroll	1/Scroll	1/Scroll
<b>Outdoor Sound Rating (dB)<sup>5</sup></b>	76	76	76	76
<b>Outdoor Coil—Fin Type</b>	Louvered	Louvered	Louvered	Louvered
Tube Type	MicroChannel	MicroChannel	MicroChannel	MicroChannel
MicroChannel Depth in. [mm]	0.71 [18]	0.71 [18]	0.71 [18]	0.71 [18]
Face Area sq. ft. [sq. m]	9.9 [0.92]	9.9 [0.92]	9.9 [0.92]	9.9 [0.92]
Rows / FPI [FPcm]	1 / 23 [9]	1 / 23 [9]	1 / 23 [9]	1 / 23 [9]
<b>Indoor Coil—Fin Type</b>	Louvered	Louvered	Louvered	Louvered
Tube Type	MicroChannel	MicroChannel	MicroChannel	MicroChannel
MicroChannel Depth in. [mm]	1 [25.4]	1 [25.4]	1 [25.4]	1 [25.4]
Face Area sq. ft. [sq. m]	3.6 [0.33]	3.6 [0.33]	3.6 [0.33]	3.6 [0.33]
Rows / FPI [FPcm]	1 / 17 [7]	1 / 17 [7]	1 / 17 [7]	1 / 17 [7]
Refrigerant Control	TX Valves	TX Valves	TX Valves	TX Valves
Drain Connection No./Size in. [mm]	1/0.75 [19.05]	1/0.75 [19.05]	1/0.75 [19.05]	1/0.75 [19.05]
<b>Outdoor Fan—Type</b>	Propeller	Propeller	Propeller	Propeller
No. Used/Diameter in. [mm]	1/22 [558.8]	1/22 [558.8]	1/22 [558.8]	1/22 [558.8]
Drive Type/No. Speeds	Direct/1	Direct/1	Direct/1	Direct/1
CFM [L/s]	2500 [1180]	2500 [1180]	2500 [1180]	2500 [1180]
No. Motors/HP	1 at 1/3 HP	1 at 1/3 HP	1 at 1/3 HP	1 at 1/3 HP
Motor RPM	1075	1075	1075	1075
<b>Indoor Fan—Type</b>	FC Centrifugal	FC Centrifugal	FC Centrifugal	FC Centrifugal
No. Used/Diameter in. [mm]	1/10x9 [254x229]	1/10x9 [254x229]	1/10x9 [254x229]	1/10x9 [254x229]
Drive Type	Direct	Direct	Direct	Direct
No. Speeds	Multiple	Multiple	Multiple	Multiple
No. Motors	1	1	1	1
Motor HP	1/2	1/2	1/2	1/2
Motor RPM	1050	1050	1050	1050
Motor Frame Size	48	48	48	48
<b>Filter—Type</b>	Field Supplied	Field Supplied	Field Supplied	Field Supplied
Furnished	No	No	No	No
(NO.) Size Recommended in. [mm x mm x mm]	(1)1x24x24 [25x610x610]	(1)1x24x24 [25x610x610]	(1)1x24x24 [25x610x610]	(1)1x24x24 [25x610x610]
<b>Refrigerant Charge Oz. [g]</b>	46.8 [1327]	46.8 [1327]	46.8 [1327]	46.8 [1327]
<b>Weights</b>				
Net Weight lbs. [kg]	403 [183]	403 [183]	408 [185]	408 [185]
Ship Weight lbs. [kg]	413 [187]	413 [187]	418 [190]	418 [190]

See Page 33 for Notes.

[ ] Designates Metric Conversions

## NOMINAL SIZES 2-5 TONS [7.0-17.6 kW]

Model RGEA15 Series	036ACT061AA	036ACT081AA	036ACT101AA	036ADT061AA
<b>Cooling Performance<sup>1</sup></b>				<b>CONTINUED</b> →
Gross Cooling Capacity Btu [kW]	36,000 [10.55]	36,000 [10.55]	36,000 [10.55]	36,000 [10.55]
EER/SEER <sup>2</sup>	12/15	12/15	12/15	12/15
Nominal CFM/AHRI Rated CFM [L/s]	1200/1200 [566/566]	1200/1200 [566/566]	1200/1200 [566/566]	1200/1200 [566/566]
AHRI Net Cooling Capacity Btu [kW]	35,000 [10.25]	35,000 [10.25]	35,000 [10.25]	35,000 [10.25]
Net Sensible Capacity Btu [kW]	25,400 [7.44]	25,400 [7.44]	25,400 [7.44]	25,400 [7.44]
Net Latent Capacity Btu [kW]	9,600 [2.81]	9,600 [2.81]	9,600 [2.81]	9,600 [2.81]
Net System Power kW	2.77	2.77	2.77	2.77
<b>Heating Performance (Gas)<sup>3</sup></b>				
Heating Input Btu [kW]	60,000 [17.58]	80,000 [23.44]	100,000 [29.3]	60,000 [17.58]
Heating Output Btu [kW]	48,000 [14.06]	65,000 [19.04]	81,000 [23.73]	48,000 [14.06]
Temperature Rise Range °F [°C]	40-70 [22.2-38.9]	35-65 [19.4-36.1]	45-75 [25-41.7]	40-70 [22.2-38.9]
AFUE % <sup>4</sup>	81	81	81	81
Steady State Efficiency (%)	82	82	82	82
No. Burners	3	3	3	3
No. Stages	1	1	1	1
Gas Connection Pipe Size in. [mm]	0.5 [12.7]	0.5 [12.7]	0.5 [12.7]	0.5 [12.7]
<b>Compressor</b>				
No./Type	1/Scroll	1/Scroll	1/Scroll	1/Scroll
<b>Outdoor Sound Rating (dB)<sup>5</sup></b>	76	76	76	76
<b>Outdoor Coil—Fin Type</b>	Louvered	Louvered	Louvered	Louvered
Tube Type	MicroChannel	MicroChannel	MicroChannel	MicroChannel
MicroChannel Depth in. [mm]	0.71 [18]	0.71 [18]	0.71 [18]	0.71 [18]
Face Area sq. ft. [sq. m]	9.8 [0.91]	9.8 [0.91]	9.8 [0.91]	9.8 [0.91]
Rows / FPI [FPcm]	1 / 23 [9]	1 / 23 [9]	1 / 23 [9]	1 / 23 [9]
<b>Indoor Coil—Fin Type</b>	Louvered	Louvered	Louvered	Louvered
Tube Type	MicroChannel	MicroChannel	MicroChannel	MicroChannel
MicroChannel Depth in. [mm]	1 [25.4]	1 [25.4]	1 [25.4]	1 [25.4]
Face Area sq. ft. [sq. m]	3.6 [0.33]	3.6 [0.33]	3.6 [0.33]	3.6 [0.33]
Rows / FPI [FPcm]	1 / 17 [7]	1 / 17 [7]	1 / 17 [7]	1 / 17 [7]
Refrigerant Control	TX Valves	TX Valves	TX Valves	TX Valves
Drain Connection No./Size in. [mm]	1/0.75 [19.05]	1/0.75 [19.05]	1/0.75 [19.05]	1/0.75 [19.05]
<b>Outdoor Fan—Type</b>	Propeller	Propeller	Propeller	Propeller
No. Used/Diameter in. [mm]	1/22 [558.8]	1/22 [558.8]	1/22 [558.8]	1/22 [558.8]
Drive Type/No. Speeds	Direct/1	Direct/1	Direct/1	Direct/1
CFM [L/s]	2700 [1274]	2700 [1274]	2700 [1274]	2700 [1274]
No. Motors/HP	1 at 1/3 HP	1 at 1/3 HP	1 at 1/3 HP	1 at 1/3 HP
Motor RPM	1075	1075	1075	1075
<b>Indoor Fan—Type</b>	FC Centrifugal	FC Centrifugal	FC Centrifugal	FC Centrifugal
No. Used/Diameter in. [mm]	1/12x9 [305x229]	1/12x9 [305x229]	1/12x9 [305x229]	1/12x9 [305x229]
Drive Type	Direct	Direct	Direct	Direct
No. Speeds	Multiple	Multiple	Multiple	Multiple
No. Motors	1	1	1	1
Motor HP	1/2	1/2	1/2	1/2
Motor RPM	1075	1075	1075	1075
Motor Frame Size	48	48	48	48
<b>Filter—Type</b>	Field Supplied	Field Supplied	Field Supplied	Field Supplied
Furnished	No	No	No	No
(NO.) Size Recommended in. [mm x mm x mm]	(1)1x24x24 [25x610x610]	(1)1x24x24 [25x610x610]	(1)1x24x24 [25x610x610]	(1)1x24x24 [25x610x610]
<b>Refrigerant Charge Oz. [g]</b>	52.7 [1494]	52.7 [1494]	52.7 [1494]	52.7 [1494]
<b>Weights</b>				
Net Weight lbs. [kg]	411 [186]	416 [189]	421 [191]	411 [186]
Ship Weight lbs. [kg]	421 [191]	426 [193]	431 [196]	421 [191]

See Page 33 for Notes.

[ ] Designates Metric Conversions

## NOMINAL SIZES 2-5 TONS [7.0-17.6 kW]

Model RGEA15 Series	036ADT081AA	036ADT101AA	036AJT061AA	036AJT06XAA
<b>Cooling Performance<sup>1</sup></b>				<b>CONTINUED</b> →
Gross Cooling Capacity Btu [kW]	36,000 [10.55]	36,000 [10.55]	36,000 [10.55]	36,000 [10.55]
EER/SEER <sup>2</sup>	12/15	12/15	12/15	12/15
Nominal CFM/AHRI Rated CFM [L/s]	1200/1200 [566/566]	1200/1200 [566/566]	1200/1200 [566/566]	1200/1200 [566/566]
AHRI Net Cooling Capacity Btu [kW]	35,000 [10.25]	35,000 [10.25]	35,000 [10.25]	35,000 [10.25]
Net Sensible Capacity Btu [kW]	25,400 [7.44]	25,400 [7.44]	25,400 [7.44]	25,400 [7.44]
Net Latent Capacity Btu [kW]	9,600 [2.81]	9,600 [2.81]	9,600 [2.81]	9,600 [2.81]
Net System Power kW	2.77	2.77	2.77	2.77
<b>Heating Performance (Gas)<sup>3</sup></b>				
Heating Input Btu [kW]	80,000 [23.44]	100,000 [29.3]	60,000 [17.58]	60,000 [17.58]
Heating Output Btu [kW]	65,000 [19.04]	81,000 [23.73]	48,000 [14.06]	48,000 [14.06]
Temperature Rise Range °F [°C]	35-65 [19.4-36.1]	45-75 [25-41.7]	40-70 [22.2-38.9]	40-70 [22.2-38.9]
AFUE % <sup>4</sup>	81	81	81	81
Steady State Efficiency (%)	82	82	82	82
No. Burners	3	3	3	3
No. Stages	1	1	1	1
Gas Connection Pipe Size in. [mm]	0.5 [12.7]	0.5 [12.7]	0.5 [12.7]	0.5 [12.7]
<b>Compressor</b>				
No./Type	1/Scroll	1/Scroll	1/Scroll	1/Scroll
<b>Outdoor Sound Rating (dB)<sup>5</sup></b>	76	76	76	76
<b>Outdoor Coil—Fin Type</b>	Louvered	Louvered	Louvered	Louvered
Tube Type	MicroChannel	MicroChannel	MicroChannel	MicroChannel
MicroChannel Depth in. [mm]	0.71 [18]	0.71 [18]	0.71 [18]	0.71 [18]
Face Area sq. ft. [sq. m]	9.8 [0.91]	9.8 [0.91]	9.8 [0.91]	9.8 [0.91]
Rows / FPI [FPcm]	1 / 23 [9]	1 / 23 [9]	1 / 23 [9]	1 / 23 [9]
<b>Indoor Coil—Fin Type</b>	Louvered	Louvered	Louvered	Louvered
Tube Type	MicroChannel	MicroChannel	MicroChannel	MicroChannel
MicroChannel Depth in. [mm]	1 [25.4]	1 [25.4]	1 [25.4]	1 [25.4]
Face Area sq. ft. [sq. m]	3.6 [0.33]	3.6 [0.33]	3.6 [0.33]	3.6 [0.33]
Rows / FPI [FPcm]	1 / 17 [7]	1 / 17 [7]	1 / 17 [7]	1 / 17 [7]
Refrigerant Control	TX Valves	TX Valves	TX Valves	TX Valves
Drain Connection No./Size in. [mm]	1/0.75 [19.05]	1/0.75 [19.05]	1/0.75 [19.05]	1/0.75 [19.05]
<b>Outdoor Fan—Type</b>	Propeller	Propeller	Propeller	Propeller
No. Used/Diameter in. [mm]	1/22 [558.8]	1/22 [558.8]	1/22 [558.8]	1/22 [558.8]
Drive Type/No. Speeds	Direct/1	Direct/1	Direct/1	Direct/1
CFM [L/s]	2700 [1274]	2700 [1274]	2700 [1274]	2700 [1274]
No. Motors/HP	1 at 1/3 HP	1 at 1/3 HP	1 at 1/3 HP	1 at 1/3 HP
Motor RPM	1075	1075	1075	1075
<b>Indoor Fan—Type</b>	FC Centrifugal	FC Centrifugal	FC Centrifugal	FC Centrifugal
No. Used/Diameter in. [mm]	1/12x9 [305x229]	1/12x9 [305x229]	1/12x9 [305x229]	1/12x9 [305x229]
Drive Type	Direct	Direct	Direct	Direct
No. Speeds	Multiple	Multiple	Multiple	Multiple
No. Motors	1	1	1	1
Motor HP	1/2	1/2	1/2	1/2
Motor RPM	1075	1075	1075	1075
Motor Frame Size	48	48	48	48
<b>Filter—Type</b>	Field Supplied	Field Supplied	Field Supplied	Field Supplied
Furnished	No	No	No	No
(NO.) Size Recommended in. [mm x mm x mm]	(1)1x24x24 [25x610x610]	(1)1x24x24 [25x610x610]	(1)1x24x24 [25x610x610]	(1)1x24x24 [25x610x610]
<b>Refrigerant Charge Oz. [g]</b>	52.7 [1494]	52.7 [1494]	52.7 [1494]	52.7 [1494]
<b>Weights</b>				
Net Weight lbs. [kg]	416 [189]	421 [191]	411 [186]	411 [186]
Ship Weight lbs. [kg]	426 [193]	431 [196]	421 [191]	421 [191]

See Page 33 for Notes.

[ ] Designates Metric Conversions



## NOMINAL SIZES 2-5 TONS [7.0-17.6 kW]

Model RGEA15 Series	036AJT081AA	036AJT08XAA	036AJT101AA	036AJT10XAA
<b>Cooling Performance<sup>1</sup></b>				<b>CONTINUED</b> →
Gross Cooling Capacity Btu [kW]	36,000 [10.55]	36,000 [10.55]	36,000 [10.55]	36,000 [10.55]
EER/SEER <sup>2</sup>	12/15	12/15	12/15	12/15
Nominal CFM/AHRI Rated CFM [L/s]	1200/1200 [566/566]	1200/1200 [566/566]	1200/1200 [566/566]	1200/1200 [566/566]
AHRI Net Cooling Capacity Btu [kW]	35,000 [10.25]	35,000 [10.25]	35,000 [10.25]	35,000 [10.25]
Net Sensible Capacity Btu [kW]	25,400 [7.44]	25,400 [7.44]	25,400 [7.44]	25,400 [7.44]
Net Latent Capacity Btu [kW]	9,600 [2.81]	9,600 [2.81]	9,600 [2.81]	9,600 [2.81]
Net System Power kW	2.77	2.77	2.77	2.77
<b>Heating Performance (Gas)<sup>3</sup></b>				
Heating Input Btu [kW]	80,000 [23.44]	80,000 [23.44]	100,000 [29.3]	100,000 [29.3]
Heating Output Btu [kW]	65,000 [19.04]	65,000 [19.04]	81,000 [23.73]	81,000 [23.73]
Temperature Rise Range °F [°C]	35-65 [19.4-36.1]	35-65 [19.4-36.1]	45-75 [25-41.7]	45-75 [25-41.7]
AFUE % <sup>4</sup>	81	81	81	81
Steady State Efficiency (%)	82	82	82	82
No. Burners	3	3	3	3
No. Stages	1	1	1	1
Gas Connection Pipe Size in. [mm]	0.5 [12.7]	0.5 [12.7]	0.5 [12.7]	0.5 [12.7]
<b>Compressor</b>				
No./Type	1/Scroll	1/Scroll	1/Scroll	1/Scroll
<b>Outdoor Sound Rating (dB)<sup>5</sup></b>	76	76	76	76
<b>Outdoor Coil—Fin Type</b>	Louvered	Louvered	Louvered	Louvered
Tube Type	MicroChannel	MicroChannel	MicroChannel	MicroChannel
MicroChannel Depth in. [mm]	0.71 [18]	0.71 [18]	0.71 [18]	0.71 [18]
Face Area sq. ft. [sq. m]	9.8 [0.91]	9.8 [0.91]	9.8 [0.91]	9.8 [0.91]
Rows / FPI [FPcm]	1 / 23 [9]	1 / 23 [9]	1 / 23 [9]	1 / 23 [9]
<b>Indoor Coil—Fin Type</b>	Louvered	Louvered	Louvered	Louvered
Tube Type	MicroChannel	MicroChannel	MicroChannel	MicroChannel
MicroChannel Depth in. [mm]	1 [25.4]	1 [25.4]	1 [25.4]	1 [25.4]
Face Area sq. ft. [sq. m]	3.6 [0.33]	3.6 [0.33]	3.6 [0.33]	3.6 [0.33]
Rows / FPI [FPcm]	1 / 17 [7]	1 / 17 [7]	1 / 17 [7]	1 / 17 [7]
Refrigerant Control	TX Valves	TX Valves	TX Valves	TX Valves
Drain Connection No./Size in. [mm]	1/0.75 [19.05]	1/0.75 [19.05]	1/0.75 [19.05]	1/0.75 [19.05]
<b>Outdoor Fan—Type</b>	Propeller	Propeller	Propeller	Propeller
No. Used/Diameter in. [mm]	1/22 [558.8]	1/22 [558.8]	1/22 [558.8]	1/22 [558.8]
Drive Type/No. Speeds	Direct/1	Direct/1	Direct/1	Direct/1
CFM [L/s]	2700 [1274]	2700 [1274]	2700 [1274]	2700 [1274]
No. Motors/HP	1 at 1/3 HP	1 at 1/3 HP	1 at 1/3 HP	1 at 1/3 HP
Motor RPM	1075	1075	1075	1075
<b>Indoor Fan—Type</b>	FC Centrifugal	FC Centrifugal	FC Centrifugal	FC Centrifugal
No. Used/Diameter in. [mm]	1/12x9 [305x229]	1/12x9 [305x229]	1/12x9 [305x229]	1/12x9 [305x229]
Drive Type	Direct	Direct	Direct	Direct
No. Speeds	Multiple	Multiple	Multiple	Multiple
No. Motors	1	1	1	1
Motor HP	1/2	1/2	1/2	1/2
Motor RPM	1075	1075	1075	1075
Motor Frame Size	48	48	48	48
<b>Filter—Type</b>	Field Supplied	Field Supplied	Field Supplied	Field Supplied
Furnished	No	No	No	No
(NO.) Size Recommended in. [mm x mm x mm]	(1)1x24x24 [25x610x610]	(1)1x24x24 [25x610x610]	(1)1x24x24 [25x610x610]	(1)1x24x24 [25x610x610]
<b>Refrigerant Charge Oz. [g]</b>	52.7 [1494]	52.7 [1494]	52.7 [1494]	52.7 [1494]
<b>Weights</b>				
Net Weight lbs. [kg]	416 [189]	416 [189]	421 [191]	421 [191]
Ship Weight lbs. [kg]	426 [193]	426 [193]	431 [196]	431 [196]

See Page 33 for Notes.

[ ] Designates Metric Conversions

## NOMINAL SIZES 2-5 TONS [7.0-17.6 kW]

Model RGEA15 Series	036AJV061AA	036AJV06XAA	036AJV081AA	036AJV08XAA
<b>Cooling Performance<sup>1</sup></b>				<b>CONTINUED</b> →
Gross Cooling Capacity Btu [kW]	36,000 [10.55]	36,000 [10.55]	36,000 [10.55]	36,000 [10.55]
EER/SEER <sup>2</sup>	12/15	12/15	12/15	12/15
Nominal CFM/AHRI Rated CFM [L/s]	1200/1200 [566/566]	1200/1200 [566/566]	1200/1200 [566/566]	1200/1200 [566/566]
AHRI Net Cooling Capacity Btu [kW]	35,000 [10.25]	35,000 [10.25]	35,000 [10.25]	35,000 [10.25]
Net Sensible Capacity Btu [kW]	25,400 [7.44]	25,400 [7.44]	25,400 [7.44]	25,400 [7.44]
Net Latent Capacity Btu [kW]	9,600 [2.81]	9,600 [2.81]	9,600 [2.81]	9,600 [2.81]
Net System Power kW	2.77	2.77	2.77	2.77
<b>Heating Performance (Gas)<sup>3</sup></b>				
Heating Input Btu [kW]	60,000 [17.58]	60,000 [17.58]	80,000 [23.44]	80,000 [23.44]
Heating Output Btu [kW]	48,000 [14.06]	48,000 [14.06]	65,000 [19.04]	65,000 [19.04]
Temperature Rise Range °F [°C]	40-70 [22.2-38.9]	40-70 [22.2-38.9]	35-65 [19.4-36.1]	35-65 [19.4-36.1]
AFUE % <sup>4</sup>	81	81	81	81
Steady State Efficiency (%)	82	82	82	82
No. Burners	3	3	3	3
No. Stages	1	1	1	1
Gas Connection Pipe Size in. [mm]	0.5 [12.7]	0.5 [12.7]	0.5 [12.7]	0.5 [12.7]
<b>Compressor</b>				
No./Type	1/Scroll	1/Scroll	1/Scroll	1/Scroll
<b>Outdoor Sound Rating (dB)<sup>5</sup></b>	76	76	76	76
<b>Outdoor Coil—Fin Type</b>	Louvered	Louvered	Louvered	Louvered
Tube Type	MicroChannel	MicroChannel	MicroChannel	MicroChannel
MicroChannel Depth in. [mm]	0.71 [18]	0.71 [18]	0.71 [18]	0.71 [18]
Face Area sq. ft. [sq. m]	9.8 [0.91]	9.8 [0.91]	9.8 [0.91]	9.8 [0.91]
Rows / FPI [FPcm]	1 / 23 [9]	1 / 23 [9]	1 / 23 [9]	1 / 23 [9]
<b>Indoor Coil—Fin Type</b>	Louvered	Louvered	Louvered	Louvered
Tube Type	MicroChannel	MicroChannel	MicroChannel	MicroChannel
MicroChannel Depth in. [mm]	1 [25.4]	1 [25.4]	1 [25.4]	1 [25.4]
Face Area sq. ft. [sq. m]	3.6 [0.33]	3.6 [0.33]	3.6 [0.33]	3.6 [0.33]
Rows / FPI [FPcm]	1 / 17 [7]	1 / 17 [7]	1 / 17 [7]	1 / 17 [7]
Refrigerant Control	TX Valves	TX Valves	TX Valves	TX Valves
Drain Connection No./Size in. [mm]	1/0.75 [19.05]	1/0.75 [19.05]	1/0.75 [19.05]	1/0.75 [19.05]
<b>Outdoor Fan—Type</b>	Propeller	Propeller	Propeller	Propeller
No. Used/Diameter in. [mm]	1/22 [558.8]	1/22 [558.8]	1/22 [558.8]	1/22 [558.8]
Drive Type/No. Speeds	Direct/1	Direct/1	Direct/1	Direct/1
CFM [L/s]	2700 [1274]	2700 [1274]	2700 [1274]	2700 [1274]
No. Motors/HP	1 at 1/3 HP	1 at 1/3 HP	1 at 1/3 HP	1 at 1/3 HP
Motor RPM	1075	1075	1075	1075
<b>Indoor Fan—Type</b>	FC Centrifugal	FC Centrifugal	FC Centrifugal	FC Centrifugal
No. Used/Diameter in. [mm]	1/10x9 [254x229]	1/10x9 [254x229]	1/10x9 [254x229]	1/10x9 [254x229]
Drive Type	Direct	Direct	Direct	Direct
No. Speeds	Multiple	Multiple	Multiple	Multiple
No. Motors	1	1	1	1
Motor HP	1/2	1/2	3/4	3/4
Motor RPM	1050	1050	1050	1050
Motor Frame Size	48	48	48	48
<b>Filter—Type</b>	Field Supplied	Field Supplied	Field Supplied	Field Supplied
Furnished	No	No	No	No
(NO.) Size Recommended in. [mm x mm x mm]	(1)1x24x24 [25x610x610]	(1)1x24x24 [25x610x610]	(1)1x24x24 [25x610x610]	(1)1x24x24 [25x610x610]
<b>Refrigerant Charge Oz. [g]</b>	52.7 [1494]	52.7 [1494]	52.7 [1494]	52.7 [1494]
<b>Weights</b>				
Net Weight lbs. [kg]	411 [186]	411 [186]	416 [189]	416 [189]
Ship Weight lbs. [kg]	421 [191]	421 [191]	426 [193]	426 [193]

See Page 33 for Notes.

[ ] Designates Metric Conversions

## NOMINAL SIZES 2-5 TONS [7.0-17.6 kW]

Model RGEA15 Series	036AJV101AA	036AJV10XAA	042ACT081AA	042ACT101AA
<b>Cooling Performance<sup>1</sup></b>				<b>CONTINUED</b> →
Gross Cooling Capacity Btu [kW]	36,000 [10.55]	36,000 [10.55]	41,000 [12.01]	41,000 [12.01]
EER/SEER <sup>2</sup>	12/15	12/15	12/15	12/15
Nominal CFM/AHRI Rated CFM [L/s]	1200/1200 [566/566]	1200/1200 [566/566]	1400/1300 [661/613]	1400/1300 [661/613]
AHRI Net Cooling Capacity Btu [kW]	35,000 [10.25]	35,000 [10.25]	40,000 [11.72]	40,000 [11.72]
Net Sensible Capacity Btu [kW]	25,400 [7.44]	25,400 [7.44]	28,600 [8.38]	28,600 [8.38]
Net Latent Capacity Btu [kW]	9,600 [2.81]	9,600 [2.81]	11,400 [3.34]	11,400 [3.34]
Net System Power kW	2.77	2.77	3.28	3.28
<b>Heating Performance (Gas)<sup>3</sup></b>				
Heating Input Btu [kW]	100,000 [29.3]	100,000 [29.3]	80,000 [23.44]	100,000 [29.3]
Heating Output Btu [kW]	81,000 [23.73]	81,000 [23.73]	65,000 [19.04]	81,000 [23.73]
Temperature Rise Range °F [°C]	45-75 [25-41.7]	45-75 [25-41.7]	35-65 [19.4-36.1]	45-75 [25-41.7]
AFUE % <sup>4</sup>	81	81	81	81
Steady State Efficiency (%)	82	82	82	82
No. Burners	3	3	4	4
No. Stages	1	1	1	1
Gas Connection Pipe Size in. [mm]	0.5 [12.7]	0.5 [12.7]	0.5 [12.7]	0.5 [12.7]
<b>Compressor</b>				
No./Type	1/Scroll	1/Scroll	1/Scroll	1/Scroll
<b>Outdoor Sound Rating (dB)<sup>5</sup></b>	76	76	76	76
<b>Outdoor Coil—Fin Type</b>	Louvered	Louvered	Louvered	Louvered
Tube Type	MicroChannel	MicroChannel	MicroChannel	MicroChannel
MicroChannel Depth in. [mm]	0.71 [18]	0.71 [18]	0.71 [18]	0.71 [18]
Face Area sq. ft. [sq. m]	9.8 [0.91]	9.8 [0.91]	14.1 [1.31]	14.1 [1.31]
Rows / FPI [FPcm]	1 / 23 [9]	1 / 23 [9]	1 / 23 [9]	1 / 23 [9]
<b>Indoor Coil—Fin Type</b>	Louvered	Louvered	Louvered	Louvered
Tube Type	MicroChannel	MicroChannel	MicroChannel	MicroChannel
MicroChannel Depth in. [mm]	1 [25.4]	1 [25.4]	1 [25.4]	1 [25.4]
Face Area sq. ft. [sq. m]	3.6 [0.33]	3.6 [0.33]	3.6 [0.33]	3.6 [0.33]
Rows / FPI [FPcm]	1 / 17 [7]	1 / 17 [7]	1 / 17 [7]	1 / 17 [7]
Refrigerant Control	TX Valves	TX Valves	TX Valves	TX Valves
Drain Connection No./Size in. [mm]	1/0.75 [19.05]	1/0.75 [19.05]	1/0.75 [19.05]	1/0.75 [19.05]
<b>Outdoor Fan—Type</b>	Propeller	Propeller	Propeller	Propeller
No. Used/Diameter in. [mm]	1/22 [558.8]	1/22 [558.8]	1/22 [558.8]	1/22 [558.8]
Drive Type/No. Speeds	Direct/1	Direct/1	Direct/1	Direct/1
CFM [L/s]	2700 [1274]	2700 [1274]	3500 [1652]	3500 [1652]
No. Motors/HP	1 at 1/3 HP	1 at 1/3 HP	1 at 1/3 HP	1 at 1/3 HP
Motor RPM	1075	1075	1075	1075
<b>Indoor Fan—Type</b>	FC Centrifugal	FC Centrifugal	FC Centrifugal	FC Centrifugal
No. Used/Diameter in. [mm]	1/10x9 [254x229]	1/10x9 [254x229]	1/12x9 [305x229]	1/12x9 [305x229]
Drive Type	Direct	Direct	Direct	Direct
No. Speeds	Multiple	Multiple	Multiple	Multiple
No. Motors	1	1	1	1
Motor HP	3/4	3/4	3/4	3/4
Motor RPM	1050	1050	1075	1075
Motor Frame Size	48	48	48	48
<b>Filter—Type</b>	Field Supplied	Field Supplied	Field Supplied	Field Supplied
Furnished	No	No	No	No
(NO.) Size Recommended in. [mm x mm x mm]	(1)1x24x24 [25x610x610]	(1)1x24x24 [25x610x610]	(1)1x24x24 [25x610x610]	(1)1x24x24 [25x610x610]
<b>Refrigerant Charge Oz. [g]</b>	52.7 [1494]	52.7 [1494]	61.3 [1738]	61.3 [1738]
<b>Weights</b>				
Net Weight lbs. [kg]	421 [191]	421 [191]	445 [202]	450 [204]
Ship Weight lbs. [kg]	431 [196]	431 [196]	455 [206]	460 [209]

See Page 33 for Notes.

[ ] Designates Metric Conversions

## NOMINAL SIZES 2-5 TONS [7.0-17.6 kW]

Model RGEA15 Series	042AJT081AA	042AJT08XAA	042AJT101AA	042AJT10XAA
<b>Cooling Performance<sup>1</sup></b>				
Gross Cooling Capacity Btu [kW]	41,000 [12.01]	41,000 [12.01]	41,000 [12.01]	41,000 [12.01]
EER/SEER <sup>2</sup>	12/15	12/15	12/15	12/15
Nominal CFM/AHRI Rated CFM [L/s]	1400/1300 [661/613]	1400/1300 [661/613]	1400/1300 [661/613]	1400/1300 [661/613]
AHRI Net Cooling Capacity Btu [kW]	40,000 [11.72]	40,000 [11.72]	40,000 [11.72]	40,000 [11.72]
Net Sensible Capacity Btu [kW]	28,600 [8.38]	28,600 [8.38]	28,600 [8.38]	28,600 [8.38]
Net Latent Capacity Btu [kW]	11,400 [3.34]	11,400 [3.34]	11,400 [3.34]	11,400 [3.34]
Net System Power kW	3.28	3.28	3.28	3.28
<b>Heating Performance (Gas)<sup>3</sup></b>				
Heating Input Btu [kW]	80,000 [23.44]	80,000 [23.44]	100,000 [29.3]	100,000 [29.3]
Heating Output Btu [kW]	65,000 [19.04]	65,000 [19.04]	81,000 [23.73]	81,000 [23.73]
Temperature Rise Range °F [°C]	35-65 [19.4-36.1]	35-65 [19.4-36.1]	45-75 [25-41.7]	45-75 [25-41.7]
AFUE % <sup>4</sup>	81	81	81	81
Steady State Efficiency (%)	82	82	82	82
No. Burners	4	4	4	4
No. Stages	1	1	1	1
Gas Connection Pipe Size in. [mm]	0.5 [12.7]	0.5 [12.7]	0.5 [12.7]	0.5 [12.7]
<b>Compressor</b>				
No./Type	1/Scroll	1/Scroll	1/Scroll	1/Scroll
<b>Outdoor Sound Rating (dB)<sup>5</sup></b>				
	76	76	76	76
<b>Outdoor Coil—Fin Type</b>				
Tube Type	Louvered	Louvered	Louvered	Louvered
MicroChannel Depth in. [mm]	MicroChannel	MicroChannel	MicroChannel	MicroChannel
Face Area sq. ft. [sq. m]	0.71 [18]	0.71 [18]	0.71 [18]	0.71 [18]
Rows / FPI [FPcm]	14.1 [1.31]	14.1 [1.31]	14.1 [1.31]	14.1 [1.31]
	1 / 23 [9]	1 / 23 [9]	1 / 23 [9]	1 / 23 [9]
<b>Indoor Coil—Fin Type</b>				
Tube Type	Louvered	Louvered	Louvered	Louvered
MicroChannel Depth in. [mm]	MicroChannel	MicroChannel	MicroChannel	MicroChannel
Face Area sq. ft. [sq. m]	1 [25.4]	1 [25.4]	1 [25.4]	1 [25.4]
Rows / FPI [FPcm]	3.6 [0.33]	3.6 [0.33]	3.6 [0.33]	3.6 [0.33]
Refrigerant Control	1 / 17 [7]	1 / 17 [7]	1 / 17 [7]	1 / 17 [7]
Drain Connection No./Size in. [mm]	TX Valves	TX Valves	TX Valves	TX Valves
	1/0.75 [19.05]	1/0.75 [19.05]	1/0.75 [19.05]	1/0.75 [19.05]
<b>Outdoor Fan—Type</b>				
No. Used/Diameter in. [mm]	Propeller	Propeller	Propeller	Propeller
Drive Type/No. Speeds	1/22 [558.8]	1/22 [558.8]	1/22 [558.8]	1/22 [558.8]
CFM [L/s]	Direct/1	Direct/1	Direct/1	Direct/1
No. Motors/HP	3500 [1652]	3500 [1652]	3500 [1652]	3500 [1652]
Motor RPM	1 at 1/3 HP	1 at 1/3 HP	1 at 1/3 HP	1 at 1/3 HP
	1075	1075	1075	1075
<b>Indoor Fan—Type</b>				
No. Used/Diameter in. [mm]	FC Centrifugal	FC Centrifugal	FC Centrifugal	FC Centrifugal
Drive Type	1/12x9 [305x229]	1/12x9 [305x229]	1/12x9 [305x229]	1/12x9 [305x229]
No. Speeds	Direct	Direct	Direct	Direct
No. Motors	Multiple	Multiple	Multiple	Multiple
Motor HP	1	1	1	1
Motor RPM	3/4	3/4	3/4	3/4
Motor Frame Size	1075	1075	1075	1075
	48	48	48	48
<b>Filter—Type</b>				
Furnished	Field Supplied	Field Supplied	Field Supplied	Field Supplied
(NO.) Size Recommended in. [mm x mm x mm]	No	No	No	No
	(1)1x24x24 [25x610x610]	(1)1x24x24 [25x610x610]	(1)1x24x24 [25x610x610]	(1)1x24x24 [25x610x610]
<b>Refrigerant Charge Oz. [g]</b>				
	61.3 [1738]	61.3 [1738]	61.3 [1738]	61.3 [1738]
<b>Weights</b>				
Net Weight lbs. [kg]	445 [202]	445 [202]	450 [204]	450 [204]
Ship Weight lbs. [kg]	455 [206]	455 [206]	460 [209]	460 [209]

**CONTINUED** 

See Page 33 for Notes.

[ ] Designates Metric Conversions

## NOMINAL SIZES 2-5 TONS [7.0-17.6 kW]

Model RGEA15 Series	042AJV081AA	042AJV08XAA	042AJV101AA	042AJV10XAA
<b>Cooling Performance<sup>1</sup></b>				<b>CONTINUED</b> →
Gross Cooling Capacity Btu [kW]	41,000 [12.01]	41,000 [12.01]	41,000 [12.01]	41,000 [12.01]
EER/SEER <sup>2</sup>	12/15	12/15	12/15	12/15
Nominal CFM/AHRI Rated CFM [L/s]	1400/1300 [661/613]	1400/1300 [661/613]	1400/1300 [661/613]	1400/1300 [661/613]
AHRI Net Cooling Capacity Btu [kW]	40,000 [11.72]	40,000 [11.72]	40,000 [11.72]	40,000 [11.72]
Net Sensible Capacity Btu [kW]	28,600 [8.38]	28,600 [8.38]	28,600 [8.38]	28,600 [8.38]
Net Latent Capacity Btu [kW]	11,400 [3.34]	11,400 [3.34]	11,400 [3.34]	11,400 [3.34]
Net System Power kW	3.28	3.28	3.28	3.28
<b>Heating Performance (Gas)<sup>3</sup></b>				
Heating Input Btu [kW]	80,000 [23.44]	80,000 [23.44]	100,000 [29.3]	100,000 [29.3]
Heating Output Btu [kW]	65,000 [19.04]	65,000 [19.04]	81,000 [23.73]	81,000 [23.73]
Temperature Rise Range °F [°C]	35-65 [19.4-36.1]	35-65 [19.4-36.1]	45-75 [25-41.7]	45-75 [25-41.7]
AFUE % <sup>4</sup>	81	81	81	81
Steady State Efficiency (%)	82	82	82	82
No. Burners	4	4	4	4
No. Stages	1	1	1	1
Gas Connection Pipe Size in. [mm]	0.5 [12.7]	0.5 [12.7]	0.5 [12.7]	0.5 [12.7]
<b>Compressor</b>				
No./Type	1/Scroll	1/Scroll	1/Scroll	1/Scroll
<b>Outdoor Sound Rating (dB)<sup>5</sup></b>	76	76	76	76
<b>Outdoor Coil—Fin Type</b>	Louvered	Louvered	Louvered	Louvered
Tube Type	MicroChannel	MicroChannel	MicroChannel	MicroChannel
MicroChannel Depth in. [mm]	0.71 [18]	0.71 [18]	0.71 [18]	0.71 [18]
Face Area sq. ft. [sq. m]	14.1 [1.31]	14.1 [1.31]	14.1 [1.31]	14.1 [1.31]
Rows / FPI [FPcm]	1 / 23 [9]	1 / 23 [9]	1 / 23 [9]	1 / 23 [9]
<b>Indoor Coil—Fin Type</b>	Louvered	Louvered	Louvered	Louvered
Tube Type	MicroChannel	MicroChannel	MicroChannel	MicroChannel
MicroChannel Depth in. [mm]	1 [25.4]	1 [25.4]	1 [25.4]	1 [25.4]
Face Area sq. ft. [sq. m]	3.6 [0.33]	3.6 [0.33]	3.6 [0.33]	3.6 [0.33]
Rows / FPI [FPcm]	1 / 17 [7]	1 / 17 [7]	1 / 17 [7]	1 / 17 [7]
Refrigerant Control	TX Valves	TX Valves	TX Valves	TX Valves
Drain Connection No./Size in. [mm]	1/0.75 [19.05]	1/0.75 [19.05]	1/0.75 [19.05]	1/0.75 [19.05]
<b>Outdoor Fan—Type</b>	Propeller	Propeller	Propeller	Propeller
No. Used/Diameter in. [mm]	1/22 [558.8]	1/22 [558.8]	1/22 [558.8]	1/22 [558.8]
Drive Type/No. Speeds	Direct/1	Direct/1	Direct/1	Direct/1
CFM [L/s]	3500 [1652]	3500 [1652]	3500 [1652]	3500 [1652]
No. Motors/HP	1 at 1/3 HP	1 at 1/3 HP	1 at 1/3 HP	1 at 1/3 HP
Motor RPM	1075	1075	1075	1075
<b>Indoor Fan—Type</b>	FC Centrifugal	FC Centrifugal	FC Centrifugal	FC Centrifugal
No. Used/Diameter in. [mm]	1/10x9 [254x229]	1/10x9 [254x229]	1/10x9 [254x229]	1/10x9 [254x229]
Drive Type	Direct	Direct	Direct	Direct
No. Speeds	Multiple	Multiple	Multiple	Multiple
No. Motors	1	1	1	1
Motor HP	3/4	3/4	3/4	3/4
Motor RPM	1050	1050	1050	1050
Motor Frame Size	48	48	48	48
<b>Filter—Type</b>	Field Supplied	Field Supplied	Field Supplied	Field Supplied
Furnished	No	No	No	No
(NO.) Size Recommended in. [mm x mm x mm]	(1)1x24x24 [25x610x610]	(1)1x24x24 [25x610x610]	(1)1x24x24 [25x610x610]	(1)1x24x24 [25x610x610]
<b>Refrigerant Charge Oz. [g]</b>	61.3 [1738]	61.3 [1738]	61.3 [1738]	61.3 [1738]
<b>Weights</b>				
Net Weight lbs. [kg]	445 [202]	445 [202]	450 [204]	450 [204]
Ship Weight lbs. [kg]	455 [206]	455 [206]	460 [209]	460 [209]

See Page 33 for Notes.

[ ] Designates Metric Conversions

## NOMINAL SIZES 2-5 TONS [7.0-17.6 kW]

Model RGEA15 Series	048ACT081AA	048ACT101AA	048ADT101AA	048AJT081AA
<b>Cooling Performance<sup>1</sup></b>				<b>CONTINUED</b> →
Gross Cooling Capacity Btu [kW]	47,500 [13.92]	47,500 [13.92]	47,500 [13.92]	47,500 [13.92]
EER/SEER <sup>2</sup>	12/15	12/15	12/15	12/15
Nominal CFM/AHRI Rated CFM [L/s]	1600/1550 [755/731]	1600/1550 [755/731]	1600/1550 [755/731]	1600/1550 [755/731]
AHRI Net Cooling Capacity Btu [kW]	46,000 [13.48]	46,000 [13.48]	46,000 [13.48]	46,000 [13.48]
Net Sensible Capacity Btu [kW]	33,000 [9.67]	33,000 [9.67]	33,000 [9.67]	33,000 [9.67]
Net Latent Capacity Btu [kW]	13,000 [3.81]	13,000 [3.81]	13,000 [3.81]	13,000 [3.81]
Net System Power kW	3.66	3.66	3.66	3.66
<b>Heating Performance (Gas)<sup>3</sup></b>				
Heating Input Btu [kW]	80,000 [23.44]	100,000 [29.3]	100,000 [29.3]	80,000 [23.44]
Heating Output Btu [kW]	65,000 [19.04]	81,000 [23.73]	81,000 [23.73]	65,000 [19.04]
Temperature Rise Range °F [°C]	35-65 [19.4-36.1]	45-75 [25-41.7]	45-75 [25-41.7]	35-65 [19.4-36.1]
AFUE % <sup>4</sup>	81	81	81	81
Steady State Efficiency (%)	82	82	82	82
No. Burners	4	4	4	4
No. Stages	1	1	1	1
Gas Connection Pipe Size in. [mm]	0.5 [12.7]	0.5 [12.7]	0.5 [12.7]	0.5 [12.7]
<b>Compressor</b>				
No./Type	1/Scroll	1/Scroll	1/Scroll	1/Scroll
<b>Outdoor Sound Rating (dB)<sup>5</sup></b>	78	78	78	78
<b>Outdoor Coil—Fin Type</b>	Louvered	Louvered	Louvered	Louvered
Tube Type	MicroChannel	MicroChannel	MicroChannel	MicroChannel
MicroChannel Depth in. [mm]	0.71 [18]	0.71 [18]	0.7 [17.8]	0.7 [17.8]
Face Area sq. ft. [sq. m]	16.3 [1.51]	16.3 [1.51]	16.3 [1.51]	16.3 [1.51]
Rows / FPI [FPcm]	1 / 23 [9]	1 / 23 [9]	1 / 23 [9]	1 / 23 [9]
<b>Indoor Coil—Fin Type</b>	Louvered	Louvered	Louvered	Louvered
Tube Type	MicroChannel	MicroChannel	MicroChannel	MicroChannel
MicroChannel Depth in. [mm]	1.26 [32]	1.26 [32]	1.26 [32]	1.26 [32]
Face Area sq. ft. [sq. m]	4.1 [0.38]	4.1 [0.38]	4.1 [0.38]	4.1 [0.38]
Rows / FPI [FPcm]	1 / 20 [8]	1 / 20 [8]	1 / 20 [8]	1 / 20 [8]
Refrigerant Control	TX Valves	TX Valves	TX Valves	TX Valves
Drain Connection No./Size in. [mm]	1/0.75 [19.05]	1/0.75 [19.05]	1/0.75 [19.05]	1/0.75 [19.05]
<b>Outdoor Fan—Type</b>	Propeller	Propeller	Propeller	Propeller
No. Used/Diameter in. [mm]	1/22 [558.8]	1/22 [558.8]	1/22 [558.8]	1/22 [558.8]
Drive Type/No. Speeds	Direct/1	Direct/1	Direct/1	Direct/1
CFM [L/s]	3300 [1557]	3300 [1557]	3300 [1557]	3300 [1557]
No. Motors/HP	1 at 1/3 HP	1 at 1/3 HP	1 at 1/3 HP	1 at 1/3 HP
Motor RPM	1075	1075	1075	1075
<b>Indoor Fan—Type</b>	FC Centrifugal	FC Centrifugal	FC Centrifugal	FC Centrifugal
No. Used/Diameter in. [mm]	1/12x9 [305x229]	1/12x9 [305x229]	1/12x9 [305x229]	1/12x9 [305x229]
Drive Type	Direct	Direct	Direct	Direct
No. Speeds	Multiple	Multiple	Multiple	Multiple
No. Motors	1	1	1	1
Motor HP	3/4	3/4	3/4	3/4
Motor RPM	1075	1075	1075	1075
Motor Frame Size	48	48	48	48
<b>Filter—Type</b>	Field Supplied	Field Supplied	Field Supplied	Field Supplied
Furnished	No	No	No	No
(NO.) Size Recommended in. [mm x mm x mm]	(1)1x24x24 [25x610x610]	(1)1x24x24 [25x610x610]	(1)1x24x24 [25x610x610]	(1)1x24x24 [25x610x610]
<b>Refrigerant Charge Oz. [g]</b>	85.3 [2418]	85.3 [2418]	85.3 [2418]	85.3 [2418]
<b>Weights</b>				
Net Weight lbs. [kg]	492 [223]	497 [225]	497 [225]	492 [223]
Ship Weight lbs. [kg]	502 [228]	507 [230]	507 [230]	502 [228]

See Page 33 for Notes.

[ ] Designates Metric Conversions



## NOMINAL SIZES 2-5 TONS [7.0-17.6 kW]

Model RGEA15 Series	048AJT08XAA	048AJT101AA	048AJT10XAA	048AJV081AA
<b>Cooling Performance<sup>1</sup></b>				<b>CONTINUED</b> →
Gross Cooling Capacity Btu [kW]	47,500 [13.92]	47,500 [13.92]	47,500 [13.92]	47,500 [13.92]
EER/SEER <sup>2</sup>	12/15	12/15	12/15	12/15
Nominal CFM/AHRI Rated CFM [L/s]	1600/1550 [755/731]	1600/1550 [755/731]	1600/1550 [755/731]	1600/1550 [755/731]
AHRI Net Cooling Capacity Btu [kW]	46,000 [13.48]	46,000 [13.48]	46,000 [13.48]	46,000 [13.48]
Net Sensible Capacity Btu [kW]	33,000 [9.67]	33,000 [9.67]	33,000 [9.67]	33,000 [9.67]
Net Latent Capacity Btu [kW]	13,000 [3.81]	13,000 [3.81]	13,000 [3.81]	13,000 [3.81]
Net System Power kW	3.66	3.66	3.66	3.66
<b>Heating Performance (Gas)<sup>3</sup></b>				
Heating Input Btu [kW]	80,000 [23.44]	100,000 [29.3]	100,000 [29.3]	80,000 [23.44]
Heating Output Btu [kW]	65,000 [19.04]	81,000 [23.73]	81,000 [23.73]	65,000 [19.04]
Temperature Rise Range °F [°C]	35-65 [19.4-36.1]	45-75 [25-41.7]	45-75 [25-41.7]	35-65 [19.4-36.1]
AFUE % <sup>4</sup>	81	81	81	81
Steady State Efficiency (%)	82	82	82	82
No. Burners	4	4	4	4
No. Stages	1	1	1	1
Gas Connection Pipe Size in. [mm]	0.5 [12.7]	0.5 [12.7]	0.5 [12.7]	0.5 [12.7]
<b>Compressor</b>				
No./Type	1/Scroll	1/Scroll	1/Scroll	1/Scroll
<b>Outdoor Sound Rating (dB)<sup>5</sup></b>	78	78	78	78
<b>Outdoor Coil—Fin Type</b>	Louvered	Louvered	Louvered	Louvered
Tube Type	MicroChannel	MicroChannel	MicroChannel	MicroChannel
MicroChannel Depth in. [mm]	0.7 [17.8]	0.7 [17.8]	0.7 [17.8]	0.7 [17.8]
Face Area sq. ft. [sq. m]	16.3 [1.51]	16.3 [1.51]	16.3 [1.51]	16.3 [1.51]
Rows / FPI [FPcm]	1 / 23 [9]	1 / 23 [9]	1 / 23 [9]	1 / 23 [9]
<b>Indoor Coil—Fin Type</b>	Louvered	Louvered	Louvered	Louvered
Tube Type	MicroChannel	MicroChannel	MicroChannel	MicroChannel
MicroChannel Depth in. [mm]	1.26 [32]	1.26 [32]	1.26 [32]	1.26 [32]
Face Area sq. ft. [sq. m]	4.1 [0.38]	4.1 [0.38]	4.1 [0.38]	4.1 [0.38]
Rows / FPI [FPcm]	1 / 20 [8]	1 / 20 [8]	1 / 20 [8]	1 / 20 [8]
Refrigerant Control	TX Valves	TX Valves	TX Valves	TX Valves
Drain Connection No./Size in. [mm]	1/0.75 [19.05]	1/0.75 [19.05]	1/0.75 [19.05]	1/0.75 [19.05]
<b>Outdoor Fan—Type</b>	Propeller	Propeller	Propeller	Propeller
No. Used/Diameter in. [mm]	1/22 [558.8]	1/22 [558.8]	1/22 [558.8]	1/22 [558.8]
Drive Type/No. Speeds	Direct/1	Direct/1	Direct/1	Direct/1
CFM [L/s]	3300 [1557]	3300 [1557]	3300 [1557]	3300 [1557]
No. Motors/HP	1 at 1/3 HP	1 at 1/3 HP	1 at 1/3 HP	1 at 1/3 HP
Motor RPM	1075	1075	1075	1075
<b>Indoor Fan—Type</b>	FC Centrifugal	FC Centrifugal	FC Centrifugal	FC Centrifugal
No. Used/Diameter in. [mm]	1/12x9 [305x229]	1/12x9 [305x229]	1/12x9 [305x229]	1/12x9 [305x229]
Drive Type	Direct	Direct	Direct	Direct
No. Speeds	Multiple	Multiple	Multiple	Multiple
No. Motors	1	1	1	1
Motor HP	3/4	3/4	3/4	1
Motor RPM	1075	1075	1075	1050
Motor Frame Size	48	48	48	48
<b>Filter—Type</b>	Field Supplied	Field Supplied	Field Supplied	Field Supplied
Furnished	No	No	No	No
(NO.) Size Recommended in. [mm x mm x mm]	(1)1x24x24 [25x610x610]	(1)1x24x24 [25x610x610]	(1)1x24x24 [25x610x610]	(1)1x24x24 [25x610x610]
<b>Refrigerant Charge Oz. [g]</b>	85.3 [2418]	85.3 [2418]	85.3 [2418]	85.3 [2418]
<b>Weights</b>				
Net Weight lbs. [kg]	492 [223]	497 [225]	497 [225]	492 [223]
Ship Weight lbs. [kg]	502 [228]	507 [230]	507 [230]	502 [228]

See Page 33 for Notes.

[ ] Designates Metric Conversions

## NOMINAL SIZES 2-5 TONS [7.0-17.6 kW]

Model RGEA15 Series	048AJV08XAA	048AJV101AA	048AJV10XAA
<b>Cooling Performance<sup>1</sup></b>			<b>CONTINUED</b> →
Gross Cooling Capacity Btu [kW]	47,500 [13.92]	47,500 [13.92]	47,500 [13.92]
EER/SEER <sup>2</sup>	42719	42719	42719
Nominal CFM/AHRI Rated CFM [L/s]	1600/1550 [755/731]	1600/1550 [755/731]	1600/1550 [755/731]
AHRI Net Cooling Capacity Btu [kW]	46,000 [13.48]	46,000 [13.48]	46,000 [13.48]
Net Sensible Capacity Btu [kW]	33,000 [9.67]	33,000 [9.67]	33,000 [9.67]
Net Latent Capacity Btu [kW]	13,000 [3.81]	13,000 [3.81]	13,000 [3.81]
Net System Power kW	3.66	3.66	3.66
<b>Heating Performance (Gas)<sup>3</sup></b>			
Heating Input Btu [kW]	80,000 [23.44]	100,000 [29.3]	100,000 [29.3]
Heating Output Btu [kW]	65,000 [19.04]	81,000 [23.73]	81,000 [23.73]
Temperature Rise Range °F [°C]	35-65 [19.4-36.1]	45-75 [25-41.7]	45-75 [25-41.7]
AFUE % <sup>4</sup>	81	81	81
Steady State Efficiency (%)	82	82	82
No. Burners	4	4	4
No. Stages	1	1	1
Gas Connection Pipe Size in. [mm]	0.5 [12.7]	0.5 [12.7]	0.5 [12.7]
<b>Compressor</b>			
No./Type	1/Scroll	1/Scroll	1/Scroll
<b>Outdoor Sound Rating (dB)<sup>5</sup></b>	78	78	78
<b>Outdoor Coil—Fin Type</b>	Louvered	Louvered	Louvered
Tube Type	MicroChannel	MicroChannel	MicroChannel
MicroChannel Depth in. [mm]	0.7 [17.8]	0.7 [17.8]	0.7 [17.8]
Face Area sq. ft. [sq. m]	16.3 [1.51]	16.3 [1.51]	16.3 [1.51]
Rows / FPI [FPcm]	1 / 23 [9]	1 / 23 [9]	1 / 23 [9]
<b>Indoor Coil—Fin Type</b>	Louvered	Louvered	Louvered
Tube Type	MicroChannel	MicroChannel	MicroChannel
MicroChannel Depth in. [mm]	1.26 [32]	1.26 [32]	1.26 [32]
Face Area sq. ft. [sq. m]	4.1 [0.38]	4.1 [0.38]	4.1 [0.38]
Rows / FPI [FPcm]	1 / 20 [8]	1 / 20 [8]	1 / 20 [8]
Refrigerant Control	TX Valves	TX Valves	TX Valves
Drain Connection No./Size in. [mm]	1/0.75 [19.05]	1/0.75 [19.05]	1/0.75 [19.05]
<b>Outdoor Fan—Type</b>	Propeller	Propeller	Propeller
No. Used/Diameter in. [mm]	1/22 [558.8]	1/22 [558.8]	1/22 [558.8]
Drive Type/No. Speeds	Direct/1	Direct/1	Direct/1
CFM [L/s]	3300 [1557]	3300 [1557]	3300 [1557]
No. Motors/HP	1 at 1/3 HP	1 at 1/3 HP	1 at 1/3 HP
Motor RPM	1075	1075	1075
<b>Indoor Fan—Type</b>	FC Centrifugal	FC Centrifugal	FC Centrifugal
No. Used/Diameter in. [mm]	1/12x9 [305x229]	1/12x9 [305x229]	1/12x9 [305x229]
Drive Type	Direct	Direct	Direct
No. Speeds	Multiple	Multiple	Multiple
No. Motors	1	1	1
Motor HP	1	1	1
Motor RPM	1050	1050	1050
Motor Frame Size	48	48	48
<b>Filter—Type</b>	Field Supplied	Field Supplied	Field Supplied
Furnished	No	No	No
(NO.) Size Recommended in. [mm x mm x mm]	(1)1x24x24 [25x610x610]	(1)1x24x24 [25x610x610]	(1)1x24x24 [25x610x610]
<b>Refrigerant Charge Oz. [g]</b>	85.3 [2418]	85.3 [2418]	85.3 [2418]
<b>Weights</b>			
Net Weight lbs. [kg]	492 [223]	497 [225]	497 [225]
Ship Weight lbs. [kg]	502 [228]	507 [230]	507 [230]

See Page 33 for Notes.

[ ] Designates Metric Conversions

## NOMINAL SIZES 2-5 TONS [7.0-17.6 kW]

Model RGEA15 Series	060ACT101AA	060ADT101AA	060AJT101AA	060AJT10XAA
<b>Cooling Performance<sup>1</sup></b>				<b>CONTINUED</b> →
Gross Cooling Capacity (2nd Stage) Btu [kW]	59,500 [17.43]	59,500 [17.43]	59,500 [17.43]	59,500 [17.43]
SEER <sup>2</sup>	15	15	15	15
EER (1st Stage/2nd Stage)	20/11	20/11	20/11	20/11
AHRI Rated CFM (1st / 2nd stage) [L/s]	1250/1850 [590/873]	1250/1850 [590/873]	1250/1850 [590/873]	1250/1850 [590/873]
AHRI Net Cooling Capacity (1st / 2nd stage) Btu [kW]	49,500/57,000 [14.5/16.7]	49,500/57,000 [14.5/16.7]	49,500/57,000 [14.5/16.7]	49,500/57,000 [14.5/16.7]
Net Sensible Capacity (1st / 2nd stage) Btu [kW]	33,800/40,700 [9.9/11.92]	33,800/40,700 [9.9/11.92]	33,800/40,700 [9.9/11.92]	33,800/40,700 [9.9/11.92]
Net Latent Capacity (1st / 2nd stage) Btu [kW]	15,700/16,300 [4.6/4.78]	15,700/16,300 [4.6/4.78]	15,700/16,300 [4.6/4.78]	15,700/16,300 [4.6/4.78]
Net System Power (1st / 2nd stage) kW	2.14/5.02	2.14/5.02	2.14/5.02	2.14/5.02
<b>Heating Performance (Gas)<sup>3</sup></b>				
Heating Input Btu [kW]	100,000 [29.3]	100,000 [29.3]	100,000 [29.3]	100,000 [29.3]
Heating Output Btu [kW]	81,000 [23.73]	81,000 [23.73]	81,000 [23.73]	81,000 [23.73]
Temperature Rise Range °F [°C]	45-75 [25-41.7]	45-75 [25-41.7]	45-75 [25-41.7]	45-75 [25-41.7]
AFUE % <sup>4</sup>	81	81	81	81
Steady State Efficiency (%)	82	82	82	82
No. Burners	5	5	5	5
No. Stages	1	1	1	1
Gas Connection Pipe Size in. [mm]	0.5 [12.7]	0.5 [12.7]	0.5 [12.7]	0.5 [12.7]
<b>Compressor</b>				
No./Type	1/Scroll	1/Scroll	1/Scroll	1/Scroll
<b>Outdoor Sound Rating (dB)<sup>5</sup></b>	78	78	78	78
<b>Outdoor Coil—Fin Type</b>	Louvered	Louvered	Louvered	Louvered
Tube Type	MicroChannel	MicroChannel	MicroChannel	MicroChannel
MicroChannel Depth in. [mm]	1 [25.4]	1 [25.4]	1 [25.4]	1 [25.4]
Face Area sq. ft. [sq. m]	15.3 [1.42]	15.3 [1.42]	15.3 [1.42]	15.3 [1.42]
Rows / FPI [FPcm]	1 / 23 [9]	1 / 23 [9]	1 / 23 [9]	1 / 23 [9]
<b>Indoor Coil—Fin Type</b>	Louvered	Louvered	Louvered	Louvered
Tube Type	MicroChannel	MicroChannel	MicroChannel	MicroChannel
MicroChannel Depth in. [mm]	1.26 [32]	1.26 [32]	1.26 [32]	1.26 [32]
Face Area sq. ft. [sq. m]	4 [0.37]	4 [0.37]	4 [0.37]	4 [0.37]
Rows / FPI [FPcm]	1 / 20 [8]	1 / 20 [8]	1 / 20 [8]	1 / 20 [8]
Refrigerant Control	TX Valves	TX Valves	TX Valves	TX Valves
Drain Connection No./Size in. [mm]	1/0.75 [19.05]	1/0.75 [19.05]	1/0.75 [19.05]	1/0.75 [19.05]
<b>Outdoor Fan—Type</b>	Propeller	Propeller	Propeller	Propeller
No. Used/Diameter in. [mm]	1/22 [558.8]	1/22 [558.8]	1/22 [558.8]	1/22 [558.8]
Drive Type/No. Speeds	Direct/1	Direct/1	Direct/1	Direct/1
CFM [L/s]	3300 [1557]	3300 [1557]	3300 [1557]	3300 [1557]
No. Motors/HP	1 at 1/3 HP	1 at 1/3 HP	1 at 1/3 HP	1 at 1/3 HP
Motor RPM	1075	1075	1075	1075
<b>Indoor Fan—Type</b>	FC Centrifugal	FC Centrifugal	FC Centrifugal	FC Centrifugal
No. Used/Diameter in. [mm]	1/12x9 [305x229]	1/12x9 [305x229]	1/12x9 [305x229]	1/12x9 [305x229]
Drive Type	Direct	Direct	Direct	Direct
No. Speeds	Multiple	Multiple	Multiple	Multiple
No. Motors	1	1	1	1
Motor HP	1	1	1	1
Motor RPM	1075	1075	1075	1075
Motor Frame Size	48	48	48	48
<b>Filter—Type</b>	Field Supplied	Field Supplied	Field Supplied	Field Supplied
Furnished	No	No	No	No
(NO.) Size Recommended in. [mm x mm x mm]	(1)1x24x30 [25x610x762]	(1)1x24x30 [25x610x762]	(1)1x24x30 [25x610x762]	(1)1x24x30 [25x610x762]
<b>Refrigerant Charge Oz. [g]</b>	89.6 [2540]	89.6 [2540]	89.6 [2540]	89.6 [2540]
<b>Weights</b>				
Net Weight lbs. [kg]	515 [234]	515 [234]	515 [234]	515 [234]
Ship Weight lbs. [kg]	525 [238]	525 [238]	525 [238]	525 [238]

See Page 33 for Notes.

[ ] Designates Metric Conversions



## NOMINAL SIZES 2-5 TONS [7.0-17.6 kW]

Model RGEA15 Series	060AJV101AA	060AJV10XAA
<b>Cooling Performance<sup>1</sup></b>		
Gross Cooling Capacity (2nd Stage) Btu [kW]	59,500 [17.43]	59,500 [17.43]
SEER <sup>2</sup>	15	15
EER (1st Stage/2nd Stage)	20/11	20/11
AHRI Rated CFM (1st / 2nd stage) [L/s]	1250/1850 [590/873]	1250/1850 [590/873]
AHRI Net Cooling Capacity (1st / 2nd stage) Btu [kW]	49,500/57,000 [14.5/16.7]	49,500/57,000 [14.5/16.7]
Net Sensible Capacity (1st / 2nd stage) Btu [kW]	33,800/40,700 [9.9/11.92]	33,800/40,700 [9.9/11.92]
Net Latent Capacity (1st / 2nd stage) Btu [kW]	15,700/16,300 [4.6/4.78]	15,700/16,300 [4.6/4.78]
Net System Power (1st / 2nd stage) kW	2.14/5.02	2.14/5.02
<b>Heating Performance (Gas)<sup>3</sup></b>		
Heating Input Btu [kW]	100,000 [29.3]	100,000 [29.3]
Heating Output Btu [kW]	81,000 [23.73]	81,000 [23.73]
Temperature Rise Range °F [°C]	45-75 [25-41.7]	45-75 [25-41.7]
AFUE % <sup>4</sup>	81	81
Steady State Efficiency (%)	82	82
No. Burners	5	5
No. Stages	1	1
Gas Connection Pipe Size in. [mm]	0.5 [12.7]	0.5 [12.7]
<b>Compressor</b>		
No./Type	1/Scroll	1/Scroll
<b>Outdoor Sound Rating (dB)<sup>5</sup></b>		
	78	78
<b>Outdoor Coil—Fin Type</b>		
Tube Type	Louvered	Louvered
MicroChannel Depth in. [mm]	MicroChannel	MicroChannel
Face Area sq. ft. [sq. m]	1 [25.4]	1 [25.4]
Rows / FPI [FPcm]	15.3 [1.42]	15.3 [1.42]
	1 / 23 [9]	1 / 23 [9]
<b>Indoor Coil—Fin Type</b>		
Tube Type	Louvered	Louvered
MicroChannel Depth in. [mm]	MicroChannel	MicroChannel
Face Area sq. ft. [sq. m]	1.26 [32]	1.26 [32]
Rows / FPI [FPcm]	4 [0.37]	4 [0.37]
Refrigerant Control	1 / 20 [8]	1 / 20 [8]
Drain Connection No./Size in. [mm]	TX Valves	TX Valves
	1/0.75 [19.05]	1/0.75 [19.05]
<b>Outdoor Fan—Type</b>		
No. Used/Diameter in. [mm]	Propeller	Propeller
Drive Type/No. Speeds	1/22 [558.8]	1/22 [558.8]
CFM [L/s]	Direct/1	Direct/1
No. Motors/HP	3300 [1557]	3300 [1557]
Motor RPM	1 at 1/3 HP	1 at 1/3 HP
	1075	1075
<b>Indoor Fan—Type</b>		
No. Used/Diameter in. [mm]	FC Centrifugal	FC Centrifugal
Drive Type	1/12x9 [305x229]	1/12x9 [305x229]
No. Speeds	Direct	Direct
No. Motors	Multiple	Multiple
Motor HP	1	1
Motor RPM	1	1
Motor Frame Size	1050	1050
	48	48
<b>Filter—Type</b>		
Furnished	Field Supplied	Field Supplied
(NO.) Size Recommended in. [mm x mm x mm]	No	No
	(1)1x24x30 [25x610x762]	(1)1x24x30 [25x610x762]
<b>Refrigerant Charge Oz. [g]</b>		
	89.6 [2540]	89.6 [2540]
<b>Weights</b>		
Net Weight lbs. [kg]	515 [234]	515 [234]
Ship Weight lbs. [kg]	525 [238]	525 [238]

See Page 33 for Notes.

[ ] Designates Metric Conversions

## NOTES:

1. Cooling Performance is rated at 95° F ambient, 80° F entering dry bulb, 67° F entering wet bulb. Gross capacity does not include the effect of fan motor heat. AHRI capacity is net and includes the effect of fan motor heat. Units are suitable for operation in CFM range shown in airflow tables. Units are certified in accordance with the Unitary Air Conditioner Equipment certification program, which is based on AHRI Standard 210/240 or 360.
2. EER and/or SEER are rated at AHRI conditions and in accordance with DOE test procedures.
3. Heating Performance limit settings and rating data were established and approved under laboratory test conditions using American National Standard Institute standards. Ratings shown are for elevations up to 2000 feet. For elevations above 2000 feet, ratings should be reduced at the rate of 4% for each 1000 feet above sea level.
4. AFUE is rated in accordance with DOE test procedures.
5. Outdoor Sound Rating shown is tested in accordance with AHRI Standard 270.



## GROSS SYSTEMS PERFORMANCE DATA—RGEA14024A

		ENTERING INDOOR AIR @ 80°F [26.7°C] dbE ①									
wbE		71°F [21.7°C]			67°F [19.4°C]			63°F [17.2°C]			
CFM [L/s]		990 [467]	900 [425]	760 [359]	990 [467]	900 [425]	760 [359]	990 [467]	900 [425]	760 [359]	
DR ①		0.18	0.15	0.12	0.18	0.15	0.12	0.18	0.15	0.12	
OUTDOOR DRY BULB TEMPERATURE °F [°C]	75 [23.9]	Total BTUH [kW] Sens BTUH [kW] Power	31.2 [9.1] 19.3 [5.7] 1.4	30.6 [9.0] 18.5 [5.4] 1.4	29.7 [8.7] 17.1 [5.0] 1.4	29.3 [8.6] 22.6 [6.6] 1.4	28.8 [8.4] 21.6 [6.3] 1.4	28.0 [8.2] 20.0 [5.9] 1.4	27.8 [8.2] 25.3 [7.4] 1.4	27.3 [8.0] 24.2 [7.1] 1.4	26.6 [7.8] 22.5 [6.6] 1.4
	80 [26.7]	Total BTUH [kW] Sens BTUH [kW] Power	30.1 [8.8] 18.7 [5.5] 1.5	29.6 [8.7] 17.9 [5.2] 1.5	28.8 [8.4] 16.6 [4.9] 1.5	28.3 [8.3] 22.0 [6.4] 1.5	27.8 [8.2] 21.0 [6.2] 1.5	27.0 [7.9] 19.5 [5.7] 1.5	26.8 [7.9] 24.7 [7.2] 1.5	26.3 [7.7] 23.6 [6.9] 1.5	25.6 [7.5] 21.9 [6.4] 1.5
	85 [29.4]	Total BTUH [kW] Sens BTUH [kW] Power	29.1 [8.5] 18.1 [5.3] 1.6	28.6 [8.4] 17.3 [5.1] 1.6	27.8 [8.1] 16.0 [4.7] 1.6	27.3 [8.0] 21.4 [6.3] 1.6	26.8 [7.9] 20.4 [6.0] 1.6	26.1 [7.6] 18.9 [5.5] 1.6	25.8 [7.6] 24.1 [7.1] 1.6	25.4 [7.4] 23.0 [6.8] 1.6	24.6 [7.2] 21.4 [6.3] 1.6
	90 [32.2]	Total BTUH [kW] Sens BTUH [kW] Power	28.1 [8.2] 17.5 [5.1] 1.7	27.6 [8.1] 16.7 [4.9] 1.7	26.8 [7.9] 15.5 [4.5] 1.7	26.3 [7.7] 20.8 [6.1] 1.7	25.8 [7.6] 19.8 [5.8] 1.7	25.1 [7.4] 18.4 [5.4] 1.7	24.8 [7.3] 23.5 [6.9] 1.7	24.4 [7.1] 22.5 [6.6] 1.7	23.7 [6.9] 20.8 [6.1] 1.7
	95 [35]	Total BTUH [kW] Sens BTUH [kW] Power	27.1 [7.9] 16.9 [5.0] 1.8	26.6 [7.8] 16.1 [4.7] 1.8	25.9 [7.6] 15.0 [4.4] 1.8	25.3 [7.4] 20.2 [5.9] 1.8	24.9 [7.3] 19.3 [5.6] 1.8	24.2 [7.1] 17.9 [5.2] 1.8	23.8 [7.0] 22.9 [6.7] 1.8	23.4 [6.8] 21.9 [6.4] 1.8	22.7 [6.7] 20.3 [5.9] 1.8
	100 [37.8]	Total BTUH [kW] Sens BTUH [kW] Power	26.1 [7.6] 16.3 [4.8] 2.0	25.6 [7.5] 15.6 [4.6] 1.9	24.9 [7.3] 14.4 [4.2] 1.9	24.3 [7.1] 19.6 [5.7] 2.0	23.9 [7.0] 18.7 [5.5] 1.9	23.2 [6.8] 17.3 [5.1] 1.9	22.8 [6.7] 22.3 [6.5] 2.0	22.4 [6.6] 21.3 [6.2] 1.9	21.7 [6.4] 19.8 [5.8] 1.9
	105 [40.6]	Total BTUH [kW] Sens BTUH [kW] Power	25.1 [7.4] 15.7 [4.6] 2.1	24.6 [7.2] 15.0 [4.4] 2.1	23.9 [7.0] 13.9 [4.1] 2.1	23.3 [6.8] 19.0 [5.6] 2.1	22.9 [6.7] 18.1 [5.3] 2.1	22.2 [6.5] 16.8 [4.9] 2.0	21.8 [6.4] 21.7 [6.4] 2.1	21.4 [6.3] 20.7 [6.1] 2.1	20.8 [6.1] 19.2 [5.6] 2.0
	110 [43.3]	Total BTUH [kW] Sens BTUH [kW] Power	24.1 [7.1] 15.1 [4.4] 2.2	23.6 [6.9] 14.4 [4.2] 2.2	23.0 [6.7] 13.4 [3.9] 2.2	22.3 [6.5] 18.4 [5.4] 2.2	21.9 [6.4] 17.5 [5.1] 2.2	21.2 [6.2] 16.3 [4.8] 2.2	20.7 [6.1] 20.7 [6.1] 2.2	20.4 [6.0] 20.2 [5.9] 2.2	19.8 [5.8] 18.7 [5.5] 2.2
	115 [46.1]	Total BTUH [kW] Sens BTUH [kW] Power	23.1 [6.8] 14.5 [4.3] 2.4	22.6 [6.6] 13.9 [4.1] 2.4	22.0 [6.4] 12.9 [3.8] 2.3	21.2 [6.2] 17.8 [5.2] 2.4	20.9 [6.1] 17.0 [5.0] 2.4	20.3 [5.9] 15.7 [4.6] 2.3	19.7 [5.8] 19.7 [5.8] 2.4	19.4 [5.7] 19.4 [5.7] 2.4	18.8 [5.5] 18.2 [5.3] 2.3
	120 [48.9]	Total BTUH [kW] Sens BTUH [kW] Power	22.0 [6.5] 13.9 [4.1] 2.6	21.6 [6.3] 13.3 [3.9] 2.5	21.0 [6.2] 12.3 [3.6] 2.5	20.2 [5.9] 17.2 [5.0] 2.6	19.9 [5.8] 16.4 [4.8] 2.5	19.3 [5.7] 15.2 [4.5] 2.5	18.7 [5.5] 18.7 [5.5] 2.6	18.4 [5.4] 18.4 [5.4] 2.5	17.9 [5.2] 17.7 [5.2] 2.5
	125 [51.7]	Total BTUH [kW] Sens BTUH [kW] Power	21.0 [6.2] 13.3 [3.9] 2.7	20.6 [6.0] 12.7 [3.7] 2.7	20.1 [5.9] 11.8 [3.5] 2.7	19.2 [5.6] 16.6 [4.9] 2.7	18.9 [5.5] 15.8 [4.6] 2.7	18.3 [5.4] 14.7 [4.3] 2.7	17.7 [5.2] 17.7 [5.2] 2.7	17.4 [5.1] 17.4 [5.1] 2.7	16.9 [4.9] 16.9 [4.9] 2.7

DR —Depression ratio  
dbE —Entering air dry bulb  
wbE —Entering air wet bulb

Total —Total capacity x 1000 BTUH  
Sens —Sensible capacity x 1000 BTUH  
Power —KW input

NOTES: ① When the entering air dry bulb is other than 80°F [27°C], adjust the sensible capacity from the table by adding [1.10 x CFM x (1 - DR) x (dbE - 80)].

[ ] Designates Metric Conversions





# GROSS SYSTEMS PERFORMANCE DATA—RGEA14030A

ENTERING INDOOR AIR @ 80°F [26.7°C] dbE ①											
wbE		71°F [21.7°C]			67°F [19.4°C]			63°F [17.2°C]			
CFM [L/s]		1100 [519]	1000 [472]	850 [401]	1100 [519]	1000 [472]	850 [401]	1100 [519]	1000 [472]	850 [401]	
DR ①		0.16	0.15	0.11	0.16	0.15	0.11	0.16	0.15	0.11	
OUTDOOR DRY BULB TEMPERATURE °F [°C]	75 [23.9]	Total BTUH [kW] Sens BTUH [kW] Power	37.0 [10.9] 21.6 [6.3] 1.7	36.4 [10.7] 20.6 [6.0] 1.6	35.4 [10.4] 19.2 [5.6] 1.6	35.0 [10.3] 25.6 [7.5] 1.7	34.4 [10.1] 24.4 [7.2] 1.6	33.4 [9.8] 22.7 [6.7] 1.6	33.2 [9.7] 28.8 [8.4] 1.6	32.6 [9.6] 27.5 [8.1] 1.6	31.7 [9.3] 25.6 [7.5] 1.6
	80 [26.7]	Total BTUH [kW] Sens BTUH [kW] Power	36.0 [10.5] 21.1 [6.2] 1.7	35.4 [10.4] 20.1 [5.9] 1.7	34.4 [10.1] 18.7 [5.5] 1.7	33.9 [9.9] 25.1 [7.4] 1.7	33.3 [9.8] 24.0 [7.0] 1.7	32.4 [9.5] 22.3 [6.5] 1.7	32.2 [9.4] 28.3 [8.3] 1.7	31.6 [9.3] 27.0 [7.9] 1.7	30.7 [9.0] 25.1 [7.4] 1.7
	85 [29.4]	Total BTUH [kW] Sens BTUH [kW] Power	34.9 [10.2] 20.6 [6.0] 1.8	34.3 [10.1] 19.7 [5.8] 1.8	33.4 [9.8] 18.3 [5.4] 1.8	32.9 [9.6] 24.6 [7.2] 1.8	32.3 [9.5] 23.5 [6.9] 1.8	31.4 [9.2] 21.8 [6.4] 1.8	31.1 [9.1] 27.8 [8.1] 1.8	30.6 [9.0] 26.5 [7.8] 1.8	29.7 [8.7] 24.7 [7.2] 1.8
	90 [32.2]	Total BTUH [kW] Sens BTUH [kW] Power	33.9 [9.9] 20.1 [5.9] 1.9	33.3 [9.7] 19.2 [5.6] 1.9	32.3 [9.5] 17.8 [5.2] 1.9	31.8 [9.3] 24.1 [7.1] 1.9	31.2 [9.2] 23.0 [6.7] 1.9	30.4 [8.9] 21.4 [6.3] 1.9	30.0 [8.8] 27.3 [8.0] 1.9	29.5 [8.6] 26.0 [7.6] 1.9	28.7 [8.4] 24.2 [7.1] 1.9
	95 [35]	Total BTUH [kW] Sens BTUH [kW] Power	32.8 [9.6] 19.5 [5.7] 2.1	32.2 [9.4] 18.6 [5.5] 2.0	31.3 [9.2] 17.3 [5.1] 2.0	30.7 [9.0] 23.5 [6.9] 2.0	30.2 [8.8] 22.5 [6.6] 2.0	29.3 [8.6] 20.9 [6.1] 2.0	28.9 [8.5] 26.7 [7.8] 2.0	28.4 [8.3] 25.5 [7.5] 2.0	27.6 [8.1] 23.7 [7.0] 2.0
	100 [37.8]	Total BTUH [kW] Sens BTUH [kW] Power	31.6 [9.3] 18.9 [5.5] 2.2	31.1 [9.1] 18.1 [5.3] 2.2	30.2 [8.9] 16.8 [4.9] 2.1	29.6 [8.7] 22.9 [6.7] 2.2	29.1 [8.5] 21.9 [6.4] 2.1	28.3 [8.3] 20.4 [6.0] 2.1	27.8 [8.2] 26.1 [7.7] 2.2	27.3 [8.0] 25.0 [7.3] 2.1	26.6 [7.8] 23.2 [6.8] 2.1
	105 [40.6]	Total BTUH [kW] Sens BTUH [kW] Power	30.5 [8.9] 18.3 [5.4] 2.3	30.0 [8.8] 17.5 [5.1] 2.3	29.2 [8.5] 16.3 [4.8] 2.3	28.5 [8.3] 22.3 [6.5] 2.3	28.0 [8.2] 21.3 [6.2] 2.3	27.2 [8.0] 19.8 [5.8] 2.2	26.7 [7.8] 25.5 [7.5] 2.3	26.2 [7.7] 24.4 [7.1] 2.3	25.5 [7.5] 22.7 [6.6] 2.2
	110 [43.3]	Total BTUH [kW] Sens BTUH [kW] Power	29.4 [8.6] 17.7 [5.2] 2.4	28.8 [8.5] 16.9 [5.0] 2.4	28.1 [8.2] 15.7 [4.6] 2.4	27.3 [8.0] 21.7 [6.4] 2.4	26.8 [7.9] 20.7 [6.1] 2.4	26.1 [7.6] 19.3 [5.6] 2.4	25.5 [7.5] 24.9 [7.3] 2.4	25.1 [7.4] 23.8 [7.0] 2.4	24.4 [7.2] 22.1 [6.5] 2.4
	115 [46.1]	Total BTUH [kW] Sens BTUH [kW] Power	28.2 [8.3] 17.0 [5.0] 2.6	27.7 [8.1] 16.3 [4.8] 2.6	26.9 [7.9] 15.1 [4.4] 2.5	26.1 [7.7] 21.0 [6.2] 2.6	25.7 [7.5] 20.1 [5.9] 2.6	25.0 [7.3] 18.7 [5.5] 2.5	24.4 [7.1] 24.2 [7.1] 2.6	23.9 [7.0] 23.1 [6.8] 2.5	23.3 [6.8] 21.5 [6.3] 2.5
	120 [48.9]	Total BTUH [kW] Sens BTUH [kW] Power	27.0 [7.9] 16.3 [4.8] 2.7	26.5 [7.8] 15.6 [4.6] 2.7	25.8 [7.6] 14.5 [4.3] 2.7	25.0 [7.3] 20.3 [6.0] 2.7	24.5 [7.2] 19.4 [5.7] 2.7	23.9 [7.0] 18.1 [5.3] 2.7	23.2 [6.8] 23.2 [6.8] 2.7	22.8 [6.7] 22.5 [6.6] 2.7	22.2 [6.5] 20.9 [6.1] 2.7
	125 [51.7]	Total BTUH [kW] Sens BTUH [kW] Power	25.8 [7.6] 15.6 [4.6] 2.9	25.4 [7.4] 14.9 [4.4] 2.9	24.7 [7.2] 13.9 [4.1] 2.8	23.8 [7.0] 19.6 [5.8] 2.9	23.3 [6.8] 18.8 [5.5] 2.9	22.7 [6.7] 17.4 [5.1] 2.8	22.0 [6.4] 22.0 [6.4] 2.9	21.6 [6.3] 21.6 [6.3] 2.9	21.0 [6.2] 20.3 [5.9] 2.8

DR —Depression ratio  
dbE —Entering air dry bulb  
wbE—Entering air wet bulb

Total —Total capacity x 1000 BTUH  
Sens —Sensible capacity x 1000 BTUH  
Power —KW input

NOTES: ① When the entering air dry bulb is other than 80°F [27°C], adjust the sensible capacity from the table by adding [1.10 x CFM x (1 - DR) x (dbE - 80)].

[ ] Designates Metric Conversions





## GROSS SYSTEMS PERFORMANCE DATA—RGEA14036A

		ENTERING INDOOR AIR @ 80°F [26.7°C] dbE ①									
wbE		71°F [21.7°C]			67°F [19.4°C]			63°F [17.2°C]			
CFM [L/s]		1320 [623]	1200 [566]	1020 [481]	1320 [623]	1200 [566]	1020 [481]	1320 [623]	1200 [566]	1020 [481]	
DR ①		0.23	0.21	0.18	0.23	0.21	0.18	0.23	0.21	0.18	
OUTDOOR DRY BULB TEMPERATURE °F [°C]	75 [23.9]	Total BTUH [kW] Sens BTUH [kW] Power	44.3 [13.0] 25.4 [7.4] 2.0	43.5 [12.8] 24.2 [7.1] 2.0	42.3 [12.4] 22.5 [6.6] 2.0	41.4 [12.1] 29.6 [8.7] 2.0	40.6 [11.9] 28.3 [8.3] 2.0	39.5 [11.6] 26.3 [7.7] 2.0	38.3 [11.2] 32.8 [9.6] 2.0	37.6 [11.0] 31.3 [9.2] 2.0	36.6 [10.7] 29.1 [8.5] 2.0
	80 [26.7]	Total BTUH [kW] Sens BTUH [kW] Power	43.0 [12.6] 24.7 [7.2] 2.1	42.2 [12.4] 23.6 [6.9] 2.1	41.1 [12.0] 21.9 [6.4] 2.1	40.0 [11.7] 28.9 [8.5] 2.1	39.3 [11.5] 27.6 [8.1] 2.1	38.2 [11.2] 25.7 [7.5] 2.1	37.0 [10.8] 32.1 [9.4] 2.1	36.3 [10.6] 30.7 [9.0] 2.1	35.3 [10.3] 28.5 [8.4] 2.1
	85 [29.4]	Total BTUH [kW] Sens BTUH [kW] Power	41.7 [12.2] 24.0 [7.0] 2.3	40.9 [12.0] 22.9 [6.7] 2.2	39.8 [11.7] 21.3 [6.2] 2.2	38.7 [11.3] 28.2 [8.3] 2.2	38.0 [11.1] 27.0 [7.9] 2.2	37.0 [10.8] 25.1 [7.3] 2.2	35.6 [10.4] 31.4 [9.2] 2.2	35.0 [10.3] 30.0 [8.8] 2.2	34.0 [10.0] 27.9 [8.2] 2.2
	90 [32.2]	Total BTUH [kW] Sens BTUH [kW] Power	40.3 [11.8] 23.2 [6.8] 2.4	39.6 [11.6] 22.2 [6.5] 2.4	38.5 [11.3] 20.7 [6.1] 2.3	37.3 [10.9] 27.5 [8.1] 2.4	36.7 [10.7] 26.3 [7.7] 2.4	35.7 [10.5] 24.4 [7.2] 2.3	34.3 [10.0] 30.7 [9.0] 2.4	33.7 [9.9] 29.3 [8.6] 2.4	32.7 [9.6] 27.3 [8.0] 2.3
	95 [35]	Total BTUH [kW] Sens BTUH [kW] Power	38.9 [11.4] 22.5 [6.6] 2.5	38.3 [11.2] 21.5 [6.3] 2.5	37.2 [10.9] 20.0 [5.9] 2.5	36.0 [10.5] 26.7 [7.8] 2.5	35.3 [10.4] 25.5 [7.5] 2.5	34.4 [10.1] 23.7 [7.0] 2.5	32.9 [9.6] 29.9 [8.8] 2.5	32.3 [9.5] 28.6 [8.4] 2.5	31.4 [9.2] 26.6 [7.8] 2.5
	100 [37.8]	Total BTUH [kW] Sens BTUH [kW] Power	37.6 [11.0] 21.7 [6.4] 2.7	36.9 [10.8] 20.7 [6.1] 2.7	35.9 [10.5] 19.3 [5.7] 2.6	34.6 [10.1] 25.9 [7.6] 2.7	34.0 [10.0] 24.8 [7.3] 2.7	33.0 [9.7] 23.0 [6.8] 2.6	31.5 [9.2] 29.1 [8.5] 2.7	30.9 [9.1] 27.8 [8.2] 2.6	30.1 [8.8] 25.9 [7.6] 2.6
	105 [40.6]	Total BTUH [kW] Sens BTUH [kW] Power	36.1 [10.6] 20.9 [6.1] 2.9	35.5 [10.4] 20.0 [5.8] 2.8	34.5 [10.1] 18.6 [5.4] 2.8	33.2 [9.7] 25.1 [7.4] 2.8	32.6 [9.5] 24.0 [7.0] 2.8	31.7 [9.3] 22.3 [6.5] 2.8	30.1 [8.8] 28.3 [8.3] 2.8	29.6 [8.7] 27.1 [7.9] 2.8	28.7 [8.4] 25.2 [7.4] 2.8
	110 [43.3]	Total BTUH [kW] Sens BTUH [kW] Power	34.7 [10.2] 20.1 [5.9] 3.0	34.1 [10.0] 19.2 [5.6] 3.0	33.2 [9.7] 17.8 [5.2] 3.0	31.7 [9.3] 24.3 [7.1] 3.0	31.2 [9.1] 23.2 [6.8] 3.0	30.3 [8.9] 21.6 [6.3] 3.0	28.7 [8.4] 27.5 [8.1] 3.0	28.2 [8.3] 26.3 [7.7] 3.0	27.4 [8.0] 24.4 [7.2] 3.0
	115 [46.1]	Total BTUH [kW] Sens BTUH [kW] Power	33.3 [9.8] 19.2 [5.6] 3.2	32.7 [9.6] 18.3 [5.4] 3.2	31.8 [9.3] 17.0 [5.0] 3.2	30.3 [8.9] 23.4 [6.9] 3.2	29.8 [8.7] 22.4 [6.6] 3.2	28.9 [8.5] 20.8 [6.1] 3.2	27.2 [8.0] 26.6 [7.8] 3.2	26.7 [7.8] 25.4 [7.5] 3.2	26.0 [7.6] 23.7 [6.9] 3.1
	120 [48.9]	Total BTUH [kW] Sens BTUH [kW] Power	31.8 [9.3] 18.3 [5.4] 3.4	31.2 [9.2] 17.5 [5.1] 3.4	30.4 [8.9] 16.3 [4.8] 3.4	28.8 [8.5] 22.5 [6.6] 3.4	28.3 [8.3] 21.5 [6.3] 3.4	27.5 [8.1] 20.0 [5.9] 3.4	25.8 [7.5] 25.7 [7.5] 3.4	25.3 [7.4] 24.6 [7.2] 3.4	24.6 [7.2] 22.9 [6.7] 3.3
	125 [51.7]	Total BTUH [kW] Sens BTUH [kW] Power	30.3 [8.9] 17.4 [5.1] 3.6	29.8 [8.7] 16.6 [4.9] 3.6	29.0 [8.5] 15.4 [4.5] 3.6	27.4 [8.0] 21.6 [6.3] 3.6	26.9 [7.9] 20.7 [6.1] 3.6	26.1 [7.7] 19.2 [5.6] 3.6	24.3 [7.1] 24.3 [7.1] 3.6	23.8 [7.0] 23.7 [6.9] 3.6	23.2 [6.8] 22.0 [6.5] 3.6

DR —Depression ratio  
dbE —Entering air dry bulb  
wbE —Entering air wet bulb

Total —Total capacity x 1000 BTUH  
Sens —Sensible capacity x 1000 BTUH  
Power —kW input

NOTES: ① When the entering air dry bulb is other than 80°F [27°C], adjust the sensible capacity from the table by adding [1.10 x CFM x (1 - DR) x (dbE - 80)].

[ ] Designates Metric Conversions







## GROSS SYSTEMS PERFORMANCE DATA—RGEA14042A

		ENTERING INDOOR AIR @ 80°F [26.7°C] dbE ①									
wbE		71°F [21.7°C]			67°F [19.4°C]			63°F [17.2°C]			
CFM [L/s]		1430 [675]	1300 [614]	1100 [519]	1430 [675]	1300 [614]	1100 [519]	1430 [675]	1300 [614]	1100 [519]	
DR ①		0.15	0.14	0.1	0.15	0.14	0.1	0.15	0.14	0.1	
OUTDOOR DRY BULB TEMPERATURE °F [°C]	75 [23.9]	Total BTUH [kW] Sens BTUH [kW] Power	50.0 [14.7] 29.2 [8.5] 2.4	49.1 [14.4] 27.9 [8.2] 2.4	47.7 [14.0] 25.9 [7.6] 2.3	47.3 [13.9] 34.3 [10.0] 2.4	46.4 [13.6] 32.7 [9.6] 2.3	45.1 [13.2] 30.4 [8.9] 2.3	44.3 [13.0] 38.5 [11.3] 2.3	43.5 [12.8] 36.8 [10.8] 2.3	42.3 [12.4] 34.2 [10.0] 2.3
	80 [26.7]	Total BTUH [kW] Sens BTUH [kW] Power	48.7 [14.3] 28.5 [8.4] 2.5	47.9 [14.0] 27.3 [8.0] 2.5	46.5 [13.6] 25.3 [7.4] 2.5	46.0 [13.5] 33.7 [9.9] 2.5	45.2 [13.2] 32.2 [9.4] 2.5	43.9 [12.9] 29.8 [8.7] 2.4	43.0 [12.6] 37.9 [11.1] 2.5	42.3 [12.4] 36.2 [10.6] 2.5	41.1 [12.0] 33.6 [9.9] 2.4
	85 [29.4]	Total BTUH [kW] Sens BTUH [kW] Power	47.4 [13.9] 27.9 [8.2] 2.7	46.6 [13.6] 26.6 [7.8] 2.6	45.2 [13.3] 24.7 [7.2] 2.6	44.7 [13.1] 33.0 [9.7] 2.6	43.9 [12.9] 31.5 [9.2] 2.6	42.6 [12.5] 29.3 [8.6] 2.6	41.7 [12.2] 37.2 [10.9] 2.6	41.0 [12.0] 35.6 [10.4] 2.6	39.8 [11.7] 33.0 [9.7] 2.6
	90 [32.2]	Total BTUH [kW] Sens BTUH [kW] Power	46.0 [13.5] 27.2 [8.0] 2.8	45.2 [13.2] 26.0 [7.6] 2.8	43.9 [12.9] 24.1 [7.1] 2.8	43.3 [12.7] 32.3 [9.5] 2.8	42.5 [12.5] 30.8 [9.0] 2.8	41.3 [12.1] 28.6 [8.4] 2.7	40.3 [11.8] 36.5 [10.7] 2.8	39.6 [11.6] 34.9 [10.2] 2.8	38.5 [11.3] 32.4 [9.5] 2.7
	95 [35]	Total BTUH [kW] Sens BTUH [kW] Power	44.6 [13.1] 26.4 [7.7] 3.0	43.8 [12.8] 25.2 [7.4] 3.0	42.6 [12.5] 23.4 [6.9] 2.9	41.8 [12.3] 31.5 [9.2] 3.0	41.1 [12.0] 30.1 [8.8] 3.0	39.9 [11.7] 27.9 [8.2] 2.9	38.9 [11.4] 35.8 [10.5] 3.0	38.2 [11.2] 34.2 [10.0] 2.9	37.1 [10.9] 31.7 [9.3] 2.9
	100 [37.8]	Total BTUH [kW] Sens BTUH [kW] Power	43.1 [12.6] 25.6 [7.5] 3.2	42.3 [12.4] 24.4 [7.2] 3.1	41.1 [12.1] 22.7 [6.6] 3.1	40.4 [11.8] 30.7 [9.0] 3.2	39.6 [11.6] 29.3 [8.6] 3.1	38.5 [11.3] 27.2 [8.0] 3.1	37.4 [11.0] 34.9 [10.2] 3.1	36.7 [10.8] 33.4 [9.8] 3.1	35.7 [10.5] 31.0 [9.1] 3.1
	105 [40.6]	Total BTUH [kW] Sens BTUH [kW] Power	41.6 [12.2] 24.7 [7.2] 3.4	40.8 [12.0] 23.6 [6.9] 3.3	39.7 [11.6] 21.9 [6.4] 3.3	38.8 [11.4] 29.8 [8.7] 3.3	38.1 [11.2] 28.5 [8.3] 3.3	37.1 [10.9] 26.4 [7.7] 3.3	35.9 [10.5] 34.1 [10.0] 3.3	35.2 [10.3] 32.5 [9.5] 3.3	34.3 [10.0] 30.2 [8.8] 3.3
	110 [43.3]	Total BTUH [kW] Sens BTUH [kW] Power	40.0 [11.7] 23.8 [7.0] 3.6	39.3 [11.5] 22.7 [6.7] 3.5	38.2 [11.2] 21.1 [6.2] 3.5	37.2 [10.9] 28.9 [8.5] 3.5	36.6 [10.7] 27.6 [8.1] 3.5	35.6 [10.4] 25.6 [7.5] 3.5	34.3 [10.0] 33.1 [9.7] 3.5	33.7 [9.9] 31.6 [9.3] 3.5	32.7 [9.6] 29.4 [8.6] 3.5
	115 [46.1]	Total BTUH [kW] Sens BTUH [kW] Power	38.3 [11.2] 22.8 [6.7] 3.8	37.7 [11.0] 21.8 [6.4] 3.7	36.6 [10.7] 20.2 [5.9] 3.7	35.6 [10.4] 27.9 [8.2] 3.8	35.0 [10.2] 26.6 [7.8] 3.7	34.0 [10.0] 24.7 [7.2] 3.7	32.7 [9.6] 32.1 [9.4] 3.7	32.1 [9.4] 30.7 [9.0] 3.7	31.2 [9.1] 28.5 [8.4] 3.7
	120 [48.9]	Total BTUH [kW] Sens BTUH [kW] Power	36.7 [10.7] 21.7 [6.4] 4.0	36.0 [10.6] 20.8 [6.1] 4.0	35.0 [10.3] 19.3 [5.6] 3.9	33.9 [9.9] 26.8 [7.9] 4.0	33.3 [9.8] 25.6 [7.5] 3.9	32.4 [9.5] 23.8 [7.0] 3.9	31.0 [9.1] 31.0 [9.1] 4.0	30.4 [8.9] 29.7 [8.7] 3.9	29.6 [8.7] 27.6 [8.1] 3.9
	125 [51.7]	Total BTUH [kW] Sens BTUH [kW] Power	34.9 [10.2] 20.6 [6.1] 4.2	34.3 [10.1] 19.7 [5.8] 4.2	33.3 [9.8] 18.3 [5.4] 4.1	32.2 [9.4] 25.8 [7.5] 4.2	31.6 [9.3] 24.6 [7.2] 4.2	30.7 [9.0] 22.8 [6.7] 4.1	29.2 [8.6] 29.2 [8.6] 4.2	28.7 [8.4] 28.7 [8.4] 4.1	27.9 [8.2] 26.6 [7.8] 4.1

DR —Depression ratio  
dbE —Entering air dry bulb  
wbE—Entering air wet bulb

Total —Total capacity x 1000 BTUH  
Sens —Sensible capacity x 1000 BTUH  
Power —KW input

NOTES: ① When the entering air dry bulb is other than 80°F [27°C], adjust the sensible capacity from the table by adding  $[1.10 \times \text{CFM} \times (1 - \text{DR}) \times (\text{dbE} - 80)]$ .

[ ] Designates Metric Conversions



## GROSS SYSTEMS PERFORMANCE DATA—RGEA14048A

		ENTERING INDOOR AIR @ 80°F [26.7°C] dbE ①									
wbE		71°F [21.7°C]			67°F [19.4°C]			63°F [17.2°C]			
CFM [L/s]		1700 [802]	1550 [732]	1320 [623]	1700 [802]	1550 [732]	1320 [623]	1700 [802]	1550 [732]	1320 [623]	
DR ①		0.21	0.19	0.17	0.21	0.19	0.17	0.21	0.19	0.17	
OUTDOOR DRY BULB TEMPERATURE °F [°C]	75 [23.9]	Total BTUH [kW] Sens BTUH [kW] Power	58.8 [17.2] 33.0 [9.7] 2.8	57.8 [16.9] 31.6 [9.3] 2.8	56.3 [16.5] 29.4 [8.6] 2.7	55.4 [16.2] 39.1 [11.5] 2.8	54.4 [15.9] 37.4 [11.0] 2.7	53.0 [15.5] 34.8 [10.2] 2.7	52.6 [15.4] 45.0 [13.2] 2.7	51.7 [15.1] 43.0 [12.6] 2.7	50.3 [14.7] 40.1 [11.7] 2.7
	80 [26.7]	Total BTUH [kW] Sens BTUH [kW] Power	57.1 [16.7] 32.2 [9.4] 2.9	56.1 [16.4] 30.8 [9.0] 2.9	54.6 [16.0] 28.7 [8.4] 2.9	53.6 [15.7] 38.3 [11.2] 2.9	52.7 [15.4] 36.6 [10.7] 2.9	51.3 [15.0] 34.1 [10.0] 2.9	50.8 [14.9] 44.2 [12.9] 2.9	49.9 [14.6] 42.3 [12.4] 2.9	48.6 [14.2] 39.3 [11.5] 2.8
	85 [29.4]	Total BTUH [kW] Sens BTUH [kW] Power	55.3 [16.2] 31.4 [9.2] 3.1	54.4 [15.9] 30.0 [8.8] 3.1	52.9 [15.5] 27.9 [8.2] 3.0	51.9 [15.2] 37.4 [11.0] 3.1	51.0 [14.9] 35.8 [10.5] 3.1	49.6 [14.5] 33.3 [9.8] 3.0	49.1 [14.4] 43.3 [12.7] 3.1	48.2 [14.1] 41.4 [12.1] 3.0	46.9 [13.7] 38.6 [11.3] 3.0
	90 [32.2]	Total BTUH [kW] Sens BTUH [kW] Power	53.6 [15.7] 30.4 [8.9] 3.3	52.6 [15.4] 29.1 [8.5] 3.3	51.2 [15.0] 27.1 [7.9] 3.2	50.1 [14.7] 36.5 [10.7] 3.3	49.2 [14.4] 34.9 [10.2] 3.2	47.9 [14.0] 32.5 [9.5] 3.2	47.3 [13.9] 42.4 [12.4] 3.2	46.5 [13.6] 40.6 [11.9] 3.2	45.2 [13.3] 37.8 [11.1] 3.2
	95 [35]	Total BTUH [kW] Sens BTUH [kW] Power	51.8 [15.2] 29.5 [8.6] 3.5	50.9 [14.9] 28.2 [8.3] 3.5	49.5 [14.5] 26.3 [7.7] 3.4	48.4 [14.2] 35.6 [10.4] 3.5	47.5 [13.9] 34.0 [10.0] 3.4	46.3 [13.6] 31.7 [9.3] 3.4	45.6 [13.4] 41.5 [12.1] 3.4	44.8 [13.1] 39.7 [11.6] 3.4	43.6 [12.8] 36.9 [10.8] 3.4
	100 [37.8]	Total BTUH [kW] Sens BTUH [kW] Power	50.1 [14.7] 28.5 [8.4] 3.7	49.2 [14.4] 27.3 [8.0] 3.7	47.9 [14.0] 25.4 [7.4] 3.6	46.6 [13.7] 34.6 [10.1] 3.7	45.8 [13.4] 33.1 [9.7] 3.7	44.6 [13.1] 30.8 [9.0] 3.6	43.8 [12.8] 40.5 [11.9] 3.7	43.1 [12.6] 38.7 [11.3] 3.6	41.9 [12.3] 36.0 [10.6] 3.6
	105 [40.6]	Total BTUH [kW] Sens BTUH [kW] Power	48.4 [14.2] 27.5 [8.1] 4.0	47.5 [13.9] 26.3 [7.7] 3.9	46.2 [13.5] 24.5 [7.2] 3.9	44.9 [13.2] 33.6 [9.8] 3.9	44.1 [12.9] 32.1 [9.4] 3.9	42.9 [12.6] 29.9 [8.8] 3.8	42.1 [12.3] 39.4 [11.6] 3.9	41.4 [12.1] 37.7 [11.1] 3.9	40.3 [11.8] 35.1 [10.3] 3.8
	110 [43.3]	Total BTUH [kW] Sens BTUH [kW] Power	46.6 [13.7] 26.4 [7.7] 4.2	45.8 [13.4] 25.3 [7.4] 4.2	44.6 [13.1] 23.5 [6.9] 4.1	43.2 [12.7] 32.5 [9.5] 4.2	42.4 [12.4] 31.1 [9.1] 4.2	41.3 [12.1] 28.9 [8.5] 4.1	40.4 [11.8] 38.4 [11.2] 4.2	39.7 [11.6] 36.7 [10.8] 4.1	38.6 [11.3] 34.2 [10.0] 4.1
	115 [46.1]	Total BTUH [kW] Sens BTUH [kW] Power	44.9 [13.2] 25.3 [7.4] 4.5	44.1 [12.9] 24.2 [7.1] 4.5	42.9 [12.6] 22.6 [6.6] 4.4	41.5 [12.2] 31.4 [9.2] 4.5	40.8 [11.9] 30.0 [8.8] 4.4	39.7 [11.6] 28.0 [8.2] 4.4	38.7 [11.3] 37.3 [10.9] 4.4	38.0 [11.1] 35.7 [10.5] 4.4	37.0 [10.8] 33.2 [9.7] 4.4
	120 [48.9]	Total BTUH [kW] Sens BTUH [kW] Power	43.2 [12.7] 24.2 [7.1] 4.8	42.5 [12.4] 23.1 [6.8] 4.8	41.3 [12.1] 21.5 [6.3] 4.7	39.8 [11.7] 30.3 [8.9] 4.8	39.1 [11.4] 28.9 [8.5] 4.7	38.0 [11.1] 26.9 [7.9] 4.7	37.0 [10.8] 36.1 [10.6] 4.7	36.3 [10.6] 34.6 [10.1] 4.7	35.3 [10.4] 32.2 [9.4] 4.6
	125 [51.7]	Total BTUH [kW] Sens BTUH [kW] Power	41.5 [12.2] 23.0 [6.7] 5.1	40.8 [12.0] 22.0 [6.4] 5.1	39.7 [11.6] 20.5 [6.0] 5.0	38.1 [11.2] 29.1 [8.5] 5.1	37.4 [11.0] 27.8 [8.2] 5.0	36.4 [10.7] 25.9 [7.6] 5.0	35.3 [10.3] 35.0 [10.2] 5.1	34.6 [10.2] 33.4 [9.8] 5.0	33.7 [9.9] 31.1 [9.1] 5.0

DR —Depression ratio  
dbE —Entering air dry bulb  
wbE —Entering air wet bulb

Total —Total capacity x 1000 BTUH  
Sens —Sensible capacity x 1000 BTUH  
Power —KW input

NOTES: ① When the entering air dry bulb is other than 80°F [27°C], adjust the sensible capacity from the table by adding  $[1.10 \times \text{CFM} \times (1 - \text{DR}) \times (\text{dbE} - 80)]$ .

[ ] Designates Metric Conversions





# GROSS SYSTEMS PERFORMANCE DATA—RGEA14060A

		ENTERING INDOOR AIR @ 80°F [26.7°C] dbE ①									
wbE		71°F [21.7°C]			67°F [19.4°C]			63°F [17.2°C]			
CFM [L/s]		1870 [883]	1700 [802]	1440 [680]	1870 [883]	1700 [802]	1440 [680]	1870 [883]	1700 [802]	1440 [680]	
DR ①		0.14	0.13	0.11	0.14	0.13	0.11	0.14	0.13	0.11	
OUTDOOR DRY BULB TEMPERATURE °F [°C]	75 [23.9]	Total BTUH [kW] Sens BTUH [kW] Power	72.1 [21.1] 40.6 [11.9] 3.5	70.8 [20.7] 38.8 [11.4] 3.5	68.8 [20.2] 36.0 [10.6] 3.5	67.8 [19.9] 47.8 [14.0] 3.5	66.6 [19.5] 45.7 [13.4] 3.5	64.7 [19.0] 42.4 [12.4] 3.4	63.6 [18.6] 54.4 [16.0] 3.5	62.4 [18.3] 52.0 [15.2] 3.5	60.7 [17.8] 48.3 [14.2] 3.4
	80 [26.7]	Total BTUH [kW] Sens BTUH [kW] Power	70.3 [20.6] 39.6 [11.6] 3.7	69.0 [20.2] 37.8 [11.1] 3.7	67.1 [19.7] 35.1 [10.3] 3.7	66.0 [19.3] 46.7 [13.7] 3.7	64.8 [19.0] 44.7 [13.1] 3.7	63.0 [18.5] 41.5 [12.2] 3.6	61.8 [18.1] 53.4 [15.6] 3.7	60.7 [17.8] 51.0 [15.0] 3.6	59.0 [17.3] 47.4 [13.9] 3.6
	85 [29.4]	Total BTUH [kW] Sens BTUH [kW] Power	68.4 [20.0] 38.5 [11.3] 4.0	67.1 [19.7] 36.8 [10.8] 3.9	65.3 [19.1] 34.1 [10.0] 3.9	64.1 [18.8] 45.7 [13.4] 3.9	62.9 [18.4] 43.6 [12.8] 3.9	61.2 [17.9] 40.5 [11.9] 3.8	59.9 [17.5] 52.3 [15.3] 3.9	58.8 [17.2] 50.0 [14.6] 3.9	57.2 [16.7] 46.4 [13.6] 3.8
	90 [32.2]	Total BTUH [kW] Sens BTUH [kW] Power	66.4 [19.5] 37.3 [10.9] 4.2	65.2 [19.1] 35.7 [10.5] 4.1	63.4 [18.6] 33.1 [9.7] 4.1	62.1 [18.2] 44.5 [13.1] 4.2	61.0 [17.9] 42.6 [12.5] 4.1	59.3 [17.4] 39.5 [11.6] 4.1	57.9 [17.0] 51.2 [15.0] 4.1	56.8 [16.7] 48.9 [14.3] 4.1	55.3 [16.2] 45.4 [13.3] 4.0
	95 [35]	Total BTUH [kW] Sens BTUH [kW] Power	64.3 [18.8] 36.2 [10.6] 4.4	63.2 [18.5] 34.6 [10.1] 4.4	61.4 [18.0] 32.1 [9.4] 4.3	60.0 [17.6] 43.4 [12.7] 4.4	58.9 [17.3] 41.4 [12.1] 4.4	57.3 [16.8] 38.5 [11.3] 4.3	55.8 [16.4] 50.0 [14.7] 4.4	54.8 [16.1] 47.8 [14.0] 4.3	53.3 [15.6] 44.4 [13.0] 4.3
	100 [37.8]	Total BTUH [kW] Sens BTUH [kW] Power	62.1 [18.2] 35.0 [10.3] 4.7	61.0 [17.9] 33.4 [9.8] 4.7	59.3 [17.4] 31.0 [9.1] 4.6	57.9 [17.0] 42.2 [12.4] 4.7	56.8 [16.7] 40.3 [11.8] 4.6	55.2 [16.2] 37.4 [11.0] 4.6	53.6 [15.7] 48.8 [14.3] 4.7	52.7 [15.4] 46.7 [13.7] 4.6	51.2 [15.0] 43.3 [12.7] 4.5
	105 [40.6]	Total BTUH [kW] Sens BTUH [kW] Power	59.9 [17.5] 33.8 [9.9] 5.0	58.8 [17.2] 32.3 [9.5] 5.0	57.2 [16.8] 30.0 [8.8] 4.9	55.6 [16.3] 41.0 [12.0] 5.0	54.6 [16.0] 39.1 [11.5] 4.9	53.1 [15.6] 36.3 [10.6] 4.9	51.4 [15.1] 47.6 [14.0] 4.9	50.5 [14.8] 45.5 [13.3] 4.9	49.1 [14.4] 42.2 [12.4] 4.8
	110 [43.3]	Total BTUH [kW] Sens BTUH [kW] Power	57.6 [16.9] 32.5 [9.5] 5.3	56.5 [16.6] 31.0 [9.1] 5.3	55.0 [16.1] 28.8 [8.4] 5.2	53.3 [15.6] 39.7 [11.6] 5.3	52.3 [15.3] 37.9 [11.1] 5.2	50.9 [14.9] 35.2 [10.3] 5.2	49.0 [14.4] 46.3 [13.6] 5.2	48.2 [14.1] 44.3 [13.0] 5.2	46.8 [13.7] 41.1 [12.0] 5.1
	115 [46.1]	Total BTUH [kW] Sens BTUH [kW] Power	55.1 [16.2] 31.2 [9.1] 5.6	54.1 [15.9] 29.8 [8.7] 5.6	52.6 [15.4] 27.7 [8.1] 5.5	50.8 [14.9] 38.4 [11.2] 5.6	49.9 [14.6] 36.7 [10.7] 5.5	48.5 [14.2] 34.0 [10.0] 5.5	46.6 [13.7] 45.0 [13.2] 5.6	45.8 [13.4] 43.0 [12.6] 5.5	44.5 [13.0] 40.0 [11.7] 5.4
	120 [48.9]	Total BTUH [kW] Sens BTUH [kW] Power	52.6 [15.4] 29.8 [8.7] 6.0	51.7 [15.1] 28.5 [8.4] 5.9	50.2 [14.7] 26.5 [7.8] 5.8	48.3 [14.2] 37.0 [10.8] 5.9	47.5 [13.9] 35.4 [10.4] 5.9	46.1 [13.5] 32.8 [9.6] 5.8	44.1 [12.9] 43.7 [12.8] 5.9	43.3 [12.7] 41.7 [12.2] 5.9	42.1 [12.3] 38.8 [11.4] 5.8
	125 [51.7]	Total BTUH [kW] Sens BTUH [kW] Power	50.0 [14.7] 28.5 [8.3] 6.3	49.1 [14.4] 27.2 [8.0] 6.3	47.8 [14.0] 25.2 [7.4] 6.2	45.7 [13.4] 35.6 [10.4] 6.3	44.9 [13.2] 34.1 [10.0] 6.2	43.7 [12.8] 31.6 [9.3] 6.2	41.5 [12.2] 41.5 [12.2] 6.3	40.8 [11.9] 40.4 [11.8] 6.2	39.6 [11.6] 37.5 [11.0] 6.1

DR —Depression ratio  
dbE —Entering air dry bulb  
wbE—Entering air wet bulb

Total —Total capacity x 1000 BTUH  
Sens —Sensible capacity x 1000 BTUH  
Power —KW input

NOTES: ① When the entering air dry bulb is other than 80°F [27°C], adjust the sensible capacity from the table by adding  $[1.10 \times \text{CFM} \times (1 - \text{DR}) \times (\text{dbE} - 80)]$ .

[ ] Designates Metric Conversions





## GROSS SYSTEMS PERFORMANCE DATA— RGEA15024A

		ENTERING INDOOR AIR @ 80°F [26.7°C] dbE ①									
wbE		71°F [21.7°C]			67°F [19.4°C]			63°F [17.2°C]			
CFM [L/s]		990 [467]	900 [425]	760 [359]	990 [467]	900 [425]	760 [359]	990 [467]	900 [425]	760 [359]	
DR ①		0.21	0.19	0.15	0.21	0.19	0.15	0.21	0.19	0.15	
OUTDOOR DRY BULB TEMPERATURE °F [°C]	75 [23.9]	Total BTUH [kW] Sens BTUH [kW] Power	30.9 [9.1] 18.7 [5.5] 1.4	30.4 [8.9] 17.9 [5.2] 1.4	29.5 [8.7] 16.6 [4.9] 1.4	29.1 [8.5] 21.9 [6.4] 1.4	28.6 [8.4] 20.9 [6.1] 1.4	27.8 [8.1] 19.4 [5.7] 1.4	27.5 [8.1] 24.6 [7.2] 1.4	27.0 [7.9] 23.5 [6.9] 1.4	26.2 [7.7] 21.8 [6.4] 1.4
	80 [26.7]	Total BTUH [kW] Sens BTUH [kW] Power	30.0 [8.8] 18.2 [5.3] 1.5	29.4 [8.6] 17.4 [5.1] 1.5	28.6 [8.4] 16.1 [4.7] 1.5	28.1 [8.2] 21.4 [6.3] 1.5	27.6 [8.1] 20.4 [6.0] 1.5	26.8 [7.9] 18.9 [5.5] 1.5	26.5 [7.8] 24.0 [7.0] 1.5	26.0 [7.6] 23.0 [6.7] 1.5	25.3 [7.4] 21.3 [6.2] 1.5
	85 [29.4]	Total BTUH [kW] Sens BTUH [kW] Power	29.0 [8.5] 17.6 [5.2] 1.6	28.5 [8.3] 16.8 [4.9] 1.6	27.7 [8.1] 15.6 [4.6] 1.6	27.1 [8.0] 20.8 [6.1] 1.6	26.7 [7.8] 19.9 [5.8] 1.6	25.9 [7.6] 18.4 [5.4] 1.6	25.5 [7.5] 23.5 [6.9] 1.6	25.1 [7.3] 22.4 [6.6] 1.6	24.4 [7.1] 20.8 [6.1] 1.6
	90 [32.2]	Total BTUH [kW] Sens BTUH [kW] Power	28.0 [8.2] 17.0 [5.0] 1.7	27.5 [8.1] 16.3 [4.8] 1.7	26.7 [7.8] 15.1 [4.4] 1.7	26.1 [7.7] 20.2 [5.9] 1.7	25.7 [7.5] 19.3 [5.7] 1.7	25.0 [7.3] 17.9 [5.3] 1.7	24.5 [7.2] 22.9 [6.7] 1.7	24.1 [7.1] 21.9 [6.4] 1.7	23.4 [6.9] 20.3 [5.9] 1.7
	95 [35]	Total BTUH [kW] Sens BTUH [kW] Power	27.0 [7.9] 16.5 [4.8] 1.9	26.5 [7.8] 15.7 [4.6] 1.8	25.7 [7.5] 14.6 [4.3] 1.8	25.1 [7.4] 19.7 [5.8] 1.8	24.7 [7.2] 18.8 [5.5] 1.8	24.0 [7.0] 17.4 [5.1] 1.8	23.5 [6.9] 22.3 [6.5] 1.8	23.1 [6.8] 21.3 [6.2] 1.8	22.4 [6.6] 19.8 [5.8] 1.8
	100 [37.8]	Total BTUH [kW] Sens BTUH [kW] Power	25.9 [7.6] 15.9 [4.6] 2.0	25.5 [7.5] 15.2 [4.4] 2.0	24.8 [7.3] 14.1 [4.1] 1.9	24.1 [7.1] 19.1 [5.6] 2.0	23.7 [6.9] 18.2 [5.3] 2.0	23.0 [6.7] 16.9 [5.0] 1.9	22.5 [6.6] 21.7 [6.4] 2.0	22.1 [6.5] 20.8 [6.1] 1.9	21.5 [6.3] 19.2 [5.6] 1.9
	105 [40.6]	Total BTUH [kW] Sens BTUH [kW] Power	24.9 [7.3] 15.3 [4.5] 2.1	24.5 [7.2] 14.6 [4.3] 2.1	23.8 [7.0] 13.5 [4.0] 2.1	23.1 [6.8] 18.5 [5.4] 2.1	22.6 [6.6] 17.7 [5.2] 2.1	22.0 [6.4] 16.4 [4.8] 2.1	21.4 [6.3] 21.1 [6.2] 2.1	21.1 [6.2] 20.2 [5.9] 2.1	20.5 [6.0] 18.7 [5.5] 2.0
	110 [43.3]	Total BTUH [kW] Sens BTUH [kW] Power	23.8 [7.0] 14.7 [4.3] 2.3	23.4 [6.9] 14.0 [4.1] 2.2	22.7 [6.7] 13.0 [3.8] 2.2	22.0 [6.4] 17.9 [5.2] 2.2	21.6 [6.3] 17.1 [5.0] 2.2	21.0 [6.1] 15.8 [4.6] 2.2	20.4 [6.0] 20.4 [6.0] 2.2	20.0 [5.9] 19.6 [5.7] 2.2	19.4 [5.7] 18.2 [5.3] 2.2
	115 [46.1]	Total BTUH [kW] Sens BTUH [kW] Power	22.8 [6.7] 14.1 [4.1] 2.4	22.3 [6.5] 13.4 [3.9] 2.4	21.7 [6.4] 12.5 [3.6] 2.3	20.9 [6.1] 17.3 [5.1] 2.4	20.5 [6.0] 16.5 [4.8] 2.4	19.9 [5.8] 15.3 [4.5] 2.3	19.3 [5.7] 19.3 [5.7] 2.4	18.9 [5.6] 18.9 [5.6] 2.4	18.4 [5.4] 17.6 [5.2] 2.3
	120 [48.9]	Total BTUH [kW] Sens BTUH [kW] Power	21.7 [6.3] 13.4 [3.9] 2.6	21.3 [6.2] 12.8 [3.8] 2.5	20.7 [6.1] 11.9 [3.5] 2.5	19.8 [5.8] 16.6 [4.9] 2.5	19.5 [5.7] 15.9 [4.7] 2.5	18.9 [5.5] 14.7 [4.3] 2.5	18.2 [5.3] 18.2 [5.3] 2.5	17.9 [5.2] 17.9 [5.2] 2.5	17.4 [5.1] 17.1 [5.0] 2.5
	125 [51.7]	Total BTUH [kW] Sens BTUH [kW] Power	20.5 [6.0] 12.8 [3.8] 2.7	20.2 [5.9] 12.2 [3.6] 2.7	19.6 [5.7] 11.3 [3.3] 2.7	18.7 [5.5] 16.0 [4.7] 2.7	18.4 [5.4] 15.3 [4.5] 2.7	17.8 [5.2] 14.2 [4.2] 2.7	17.1 [5.0] 17.1 [5.0] 2.7	16.8 [4.9] 16.8 [4.9] 2.7	16.3 [4.8] 16.3 [4.8] 2.6

DR —Depression ratio  
dbE —Entering air dry bulb  
wbE —Entering air wet bulb

Total —Total capacity x 1000 BTUH  
Sens —Sensible capacity x 1000 BTUH  
Power —kW input

NOTES: ① When the entering air dry bulb is other than 80°F [27°C], adjust the sensible capacity from the table by adding [1.10 x CFM x (1 - DR) x (dbE - 80)].

[ ] Designates Metric Conversions





# GROSS SYSTEMS PERFORMANCE DATA—RGEA15030A

		ENTERING INDOOR AIR @ 80°F [26.7°C] dbE ①									
wbE		71°F [21.7°C]			67°F [19.4°C]			63°F [17.2°C]			
CFM [L/s]		1070 [505]	975 [460]	830 [392]	1070 [505]	975 [460]	830 [392]	1070 [505]	975 [460]	830 [392]	
DR ①		0.16	0.14	0.1	0.16	0.14	0.1	0.16	0.14	0.1	
OUTDOOR DRY BULB TEMPERATURE °F [°C]	75 [23.9]	Total BTUH [kW] Sens BTUH [kW] Power	36.8 [10.8] 21.5 [6.3] 1.7	36.1 [10.6] 20.5 [6.0] 1.7	35.2 [10.3] 19.1 [5.6] 1.6	34.3 [10.1] 25.1 [7.4] 1.7	33.7 [9.9] 24.0 [7.0] 1.6	32.8 [9.6] 22.4 [6.6] 1.6	32.4 [9.5] 28.3 [8.3] 1.6	31.8 [9.3] 27.1 [7.9] 1.6	31.0 [9.1] 25.2 [7.4] 1.6
	80 [26.7]	Total BTUH [kW] Sens BTUH [kW] Power	35.7 [10.5] 21.0 [6.1] 1.8	35.1 [10.3] 20.1 [5.9] 1.7	34.2 [10.0] 18.7 [5.5] 1.7	33.3 [9.7] 24.7 [7.2] 1.7	32.7 [9.6] 23.6 [6.9] 1.7	31.8 [9.3] 21.9 [6.4] 1.7	31.3 [9.2] 27.8 [8.2] 1.7	30.8 [9.0] 26.6 [7.8] 1.7	30.0 [8.8] 24.8 [7.3] 1.7
	85 [29.4]	Total BTUH [kW] Sens BTUH [kW] Power	34.7 [10.2] 20.5 [6.0] 1.9	34.1 [10.0] 19.6 [5.7] 1.8	33.2 [9.7] 18.2 [5.3] 1.8	32.2 [9.4] 24.2 [7.1] 1.8	31.7 [9.3] 23.1 [6.8] 1.8	30.8 [9.0] 21.5 [6.3] 1.8	30.3 [8.9] 27.4 [8.0] 1.8	29.8 [8.7] 26.2 [7.7] 1.8	29.0 [8.5] 24.3 [7.1] 1.8
	90 [32.2]	Total BTUH [kW] Sens BTUH [kW] Power	33.7 [9.9] 20.0 [5.9] 2.0	33.1 [9.7] 19.1 [5.6] 1.9	32.2 [9.4] 17.8 [5.2] 1.9	31.2 [9.1] 23.6 [6.9] 1.9	30.6 [9.0] 22.6 [6.6] 1.9	29.8 [8.7] 21.0 [6.2] 1.9	29.2 [8.6] 26.8 [7.9] 1.9	28.7 [8.4] 25.7 [7.5] 1.9	28.0 [8.2] 23.9 [7.0] 1.9
	95 [35]	Total BTUH [kW] Sens BTUH [kW] Power	32.6 [9.5] 19.4 [5.7] 2.1	32.0 [9.4] 18.6 [5.4] 2.1	31.2 [9.1] 17.3 [5.1] 2.0	30.1 [8.8] 23.1 [6.8] 2.1	29.6 [8.7] 22.1 [6.5] 2.0	28.8 [8.4] 20.5 [6.0] 2.0	28.2 [8.3] 26.3 [7.7] 2.0	27.7 [8.1] 25.1 [7.4] 2.0	26.9 [7.9] 23.4 [6.9] 2.0
	100 [37.8]	Total BTUH [kW] Sens BTUH [kW] Power	31.5 [9.2] 18.8 [5.5] 2.2	31.0 [9.1] 18.0 [5.3] 2.2	30.1 [8.8] 16.8 [4.9] 2.1	29.0 [8.5] 22.5 [6.6] 2.2	28.5 [8.4] 21.5 [6.3] 2.2	27.7 [8.1] 20.0 [5.9] 2.1	27.1 [7.9] 25.7 [7.5] 2.2	26.6 [7.8] 24.6 [7.2] 2.1	25.9 [7.6] 22.9 [6.7] 2.1
	105 [40.6]	Total BTUH [kW] Sens BTUH [kW] Power	30.4 [8.9] 18.2 [5.3] 2.3	29.9 [8.8] 17.4 [5.1] 2.3	29.1 [8.5] 16.2 [4.8] 2.3	27.9 [8.2] 21.9 [6.4] 2.3	27.4 [8.0] 20.9 [6.1] 2.3	26.7 [7.8] 19.5 [5.7] 2.3	26.0 [7.6] 25.1 [7.4] 2.3	25.6 [7.5] 24.0 [7.0] 2.3	24.9 [7.3] 22.3 [6.5] 2.2
	110 [43.3]	Total BTUH [kW] Sens BTUH [kW] Power	29.3 [8.6] 17.6 [5.2] 2.5	28.8 [8.4] 16.8 [4.9] 2.4	28.0 [8.2] 15.7 [4.6] 2.4	26.8 [7.9] 21.3 [6.2] 2.4	26.4 [7.7] 20.3 [6.0] 2.4	25.6 [7.5] 18.9 [5.5] 2.4	24.9 [7.3] 24.4 [7.2] 2.4	24.5 [7.2] 23.4 [6.9] 2.4	23.8 [7.0] 21.8 [6.4] 2.4
	115 [46.1]	Total BTUH [kW] Sens BTUH [kW] Power	28.2 [8.3] 16.9 [5.0] 2.6	27.7 [8.1] 16.2 [4.7] 2.6	27.0 [7.9] 15.1 [4.4] 2.5	25.7 [7.5] 20.6 [6.0] 2.6	25.3 [7.4] 19.7 [5.8] 2.6	24.6 [7.2] 18.3 [5.4] 2.5	23.8 [7.0] 23.8 [7.0] 2.6	23.4 [6.8] 22.7 [6.7] 2.6	22.7 [6.7] 21.2 [6.2] 2.5
	120 [48.9]	Total BTUH [kW] Sens BTUH [kW] Power	27.1 [7.9] 16.2 [4.8] 2.8	26.6 [7.8] 15.5 [4.5] 2.7	25.9 [7.6] 14.4 [4.2] 2.7	24.6 [7.2] 19.9 [5.8] 2.7	24.2 [7.1] 19.0 [5.6] 2.7	23.5 [6.9] 17.7 [5.2] 2.7	22.7 [6.6] 22.7 [6.6] 2.7	22.3 [6.5] 22.1 [6.5] 2.7	21.7 [6.3] 20.5 [6.0] 2.7
	125 [51.7]	Total BTUH [kW] Sens BTUH [kW] Power	25.9 [7.6] 15.5 [4.5] 2.9	25.5 [7.5] 14.8 [4.3] 2.9	24.8 [7.3] 13.8 [4.0] 2.8	23.4 [6.9] 19.2 [5.6] 2.9	23.0 [6.7] 18.3 [5.4] 2.9	22.4 [6.6] 17.1 [5.0] 2.8	21.5 [6.3] 21.5 [6.3] 2.9	21.1 [6.2] 21.1 [6.2] 2.9	20.6 [6.0] 19.9 [5.8] 2.8

DR —Depression ratio  
dbE —Entering air dry bulb  
wbE—Entering air wet bulb

Total —Total capacity x 1000 BTUH  
Sens —Sensible capacity x 1000 BTUH  
Power —KW input

NOTES: ① When the entering air dry bulb is other than 80°F [27°C], adjust the sensible capacity from the table by adding  $[1.10 \times \text{CFM} \times (1 - \text{DR}) \times (\text{dbE} - 80)]$ .

[ ] Designates Metric Conversions





## GROSS SYSTEMS PERFORMANCE DATA—RGEA15036A

		ENTERING INDOOR AIR @ 80°F [26.7°C] dbE ①									
wbE		71°F [21.7°C]			67°F [19.4°C]			63°F [17.2°C]			
CFM [L/s]		1320 [623]	1200 [566]	1020 [481]	1320 [623]	1200 [566]	1020 [481]	1320 [623]	1200 [566]	1020 [481]	
DR ①		0.19	0.18	0.15	0.19	0.18	0.15	0.19	0.18	0.15	
OUTDOOR DRY BULB TEMPERATURE °F [°C]	75 [23.9]	Total BTUH [kW] Sens BTUH [kW] Power	44.8 [13.1] 26.2 [7.7] 2.0	44.0 [12.9] 25.0 [7.3] 2.0	42.8 [12.5] 23.3 [6.8] 2.0	41.9 [12.3] 30.6 [9.0] 2.0	41.1 [12.1] 29.2 [8.6] 2.0	40.0 [11.7] 27.2 [8.0] 2.0	38.9 [11.4] 33.9 [9.9] 2.0	38.2 [11.2] 32.4 [9.5] 2.0	37.2 [10.9] 30.1 [8.8] 2.0
	80 [26.7]	Total BTUH [kW] Sens BTUH [kW] Power	43.5 [12.8] 25.4 [7.5] 2.1	42.7 [12.5] 24.3 [7.1] 2.1	41.6 [12.2] 22.6 [6.6] 2.1	40.6 [11.9] 29.9 [8.7] 2.1	39.9 [11.7] 28.5 [8.4] 2.1	38.8 [11.4] 26.5 [7.8] 2.1	37.6 [11.0] 33.2 [9.7] 2.1	36.9 [10.8] 31.7 [9.3] 2.1	35.9 [10.5] 29.5 [8.6] 2.1
	85 [29.4]	Total BTUH [kW] Sens BTUH [kW] Power	42.2 [12.4] 24.7 [7.2] 2.3	41.4 [12.1] 23.6 [6.9] 2.2	40.3 [11.8] 21.9 [6.4] 2.2	39.3 [11.5] 29.1 [8.5] 2.2	38.6 [11.3] 27.8 [8.1] 2.2	37.5 [11.0] 25.9 [7.6] 2.2	36.3 [10.6] 32.4 [9.5] 2.2	35.6 [10.4] 31.0 [9.1] 2.2	34.6 [10.2] 28.8 [8.4] 2.2
	90 [32.2]	Total BTUH [kW] Sens BTUH [kW] Power	40.9 [12.0] 23.9 [7.0] 2.4	40.1 [11.8] 22.9 [6.7] 2.4	39.0 [11.4] 21.3 [6.2] 2.3	37.9 [11.1] 28.3 [8.3] 2.4	37.2 [10.9] 27.1 [7.9] 2.4	36.2 [10.6] 25.2 [7.4] 2.3	34.9 [10.2] 31.6 [9.3] 2.4	34.3 [10.1] 30.2 [8.9] 2.3	33.4 [9.8] 28.1 [8.2] 2.3
	95 [35]	Total BTUH [kW] Sens BTUH [kW] Power	39.5 [11.6] 23.1 [6.8] 2.5	38.8 [11.4] 22.1 [6.5] 2.5	37.7 [11.1] 20.6 [6.0] 2.5	36.6 [10.7] 27.5 [8.1] 2.5	35.9 [10.5] 26.3 [7.7] 2.5	34.9 [10.2] 24.5 [7.2] 2.5	33.6 [9.8] 30.9 [9.0] 2.5	33.0 [9.7] 29.5 [8.6] 2.5	32.1 [9.4] 27.4 [8.0] 2.5
	100 [37.8]	Total BTUH [kW] Sens BTUH [kW] Power	38.1 [11.2] 22.3 [6.5] 2.7	37.5 [11.0] 21.3 [6.3] 2.7	36.4 [10.7] 19.9 [5.8] 2.6	35.2 [10.3] 26.7 [7.8] 2.7	34.6 [10.1] 25.6 [7.5] 2.7	33.6 [9.9] 23.8 [7.0] 2.6	32.2 [9.4] 30.1 [8.8] 2.7	31.6 [9.3] 28.7 [8.4] 2.6	30.8 [9.0] 26.7 [7.8] 2.6
	105 [40.6]	Total BTUH [kW] Sens BTUH [kW] Power	36.8 [10.8] 21.5 [6.3] 2.9	36.1 [10.6] 20.6 [6.0] 2.8	35.1 [10.3] 19.1 [5.6] 2.8	33.8 [9.9] 25.9 [7.6] 2.8	33.2 [9.7] 24.8 [7.3] 2.8	32.3 [9.5] 23.0 [6.7] 2.8	30.8 [9.0] 29.2 [8.6] 2.8	30.3 [8.9] 27.9 [8.2] 2.8	29.5 [8.6] 26.0 [7.6] 2.8
	110 [43.3]	Total BTUH [kW] Sens BTUH [kW] Power	35.4 [10.4] 20.7 [6.1] 3.0	34.7 [10.2] 19.8 [5.8] 3.0	33.8 [9.9] 18.4 [5.4] 3.0	32.4 [9.5] 25.1 [7.4] 3.0	31.9 [9.3] 24.0 [7.0] 3.0	31.0 [9.1] 22.3 [6.5] 3.0	29.4 [8.6] 28.4 [8.3] 3.0	28.9 [8.5] 27.1 [8.0] 3.0	28.1 [8.2] 25.2 [7.4] 2.9
	115 [46.1]	Total BTUH [kW] Sens BTUH [kW] Power	34.0 [10.0] 19.8 [5.8] 3.2	33.4 [9.8] 18.9 [5.5] 3.2	32.4 [9.5] 17.6 [5.2] 3.2	31.0 [9.1] 24.2 [7.1] 3.2	30.5 [8.9] 23.1 [6.8] 3.2	29.6 [8.7] 21.5 [6.3] 3.1	28.0 [8.2] 27.5 [8.1] 3.2	27.5 [8.1] 26.3 [7.7] 3.2	26.8 [7.8] 24.5 [7.2] 3.1
	120 [48.9]	Total BTUH [kW] Sens BTUH [kW] Power	32.5 [9.5] 18.9 [5.6] 3.4	32.0 [9.4] 18.1 [5.3] 3.4	31.1 [9.1] 16.8 [4.9] 3.4	29.6 [8.7] 23.3 [6.8] 3.4	29.1 [8.5] 22.3 [6.5] 3.4	28.3 [8.3] 20.7 [6.1] 3.3	26.6 [7.8] 26.6 [7.8] 3.4	26.1 [7.7] 25.5 [7.5] 3.4	25.4 [7.4] 23.7 [6.9] 3.3
	125 [51.7]	Total BTUH [kW] Sens BTUH [kW] Power	31.1 [9.1] 18.0 [5.3] 3.6	30.5 [9.0] 17.2 [5.1] 3.6	29.7 [8.7] 16.0 [4.7] 3.6	28.2 [8.3] 22.4 [6.6] 3.6	27.7 [8.1] 21.4 [6.3] 3.6	26.9 [7.9] 19.9 [5.8] 3.6	25.2 [7.4] 25.2 [7.4] 3.6	24.7 [7.2] 24.6 [7.2] 3.6	24.1 [7.0] 22.9 [6.7] 3.5

DR —Depression ratio  
dbE —Entering air dry bulb  
wbE —Entering air wet bulb

Total —Total capacity x 1000 BTUH  
Sens —Sensible capacity x 1000 BTUH  
Power —kW input

NOTES: ① When the entering air dry bulb is other than 80°F [27°C], adjust the sensible capacity from the table by adding  $[1.10 \times \text{CFM} \times (1 - \text{DR}) \times (\text{dbE} - 80)]$ .

[ ] Designates Metric Conversions





## GROSS SYSTEMS PERFORMANCE DATA—RGEA15042A

		ENTERING INDOOR AIR @ 80°F [26.7°C] dbE ①									
wbE		71°F [21.7°C]			67°F [19.4°C]			63°F [17.2°C]			
CFM [L/s]		1430 [675]	1300 [614]	1100 [519]	1430 [675]	1300 [614]	1100 [519]	1430 [675]	1300 [614]	1100 [519]	
DR ①		0.17	0.16	0.13	0.17	0.16	0.13	0.17	0.16	0.13	
OUTDOOR DRY BULB TEMPERATURE °F [°C]	75 [23.9]	Total BTUH [kW] Sens BTUH [kW] Power	50.1 [14.7] 28.6 [8.4] 2.4	49.2 [14.4] 27.3 [8.0] 2.3	47.8 [14.0] 25.3 [7.4] 2.3	47.2 [13.8] 33.9 [9.9] 2.4	46.4 [13.6] 32.4 [9.5] 2.3	45.1 [13.2] 30.0 [8.8] 2.3	44.7 [13.1] 38.8 [11.4] 2.3	43.9 [12.9] 37.1 [10.9] 2.3	42.7 [12.5] 34.4 [10.1] 2.3
	80 [26.7]	Total BTUH [kW] Sens BTUH [kW] Power	48.8 [14.3] 27.9 [8.2] 2.5	47.9 [14.0] 26.7 [7.8] 2.5	46.6 [13.6] 24.8 [7.3] 2.5	45.9 [13.5] 33.2 [9.7] 2.5	45.1 [13.2] 31.8 [9.3] 2.5	43.8 [12.8] 29.5 [8.6] 2.4	43.4 [12.7] 38.1 [11.2] 2.5	42.6 [12.5] 36.4 [10.7] 2.5	41.5 [12.1] 33.8 [9.9] 2.4
	85 [29.4]	Total BTUH [kW] Sens BTUH [kW] Power	47.4 [13.9] 27.2 [8.0] 2.7	46.6 [13.7] 26.0 [7.6] 2.6	45.3 [13.3] 24.2 [7.1] 2.6	44.6 [13.1] 32.6 [9.5] 2.6	43.8 [12.8] 31.1 [9.1] 2.6	42.6 [12.5] 28.9 [8.5] 2.6	42.1 [12.3] 37.5 [11.0] 2.6	41.3 [12.1] 35.8 [10.5] 2.6	40.2 [11.8] 33.2 [9.7] 2.6
	90 [32.2]	Total BTUH [kW] Sens BTUH [kW] Power	46.1 [13.5] 26.5 [7.8] 2.8	45.3 [13.3] 25.3 [7.4] 2.8	44.0 [12.9] 23.5 [6.9] 2.8	43.2 [12.7] 31.8 [9.3] 2.8	42.5 [12.4] 30.4 [8.9] 2.8	41.3 [12.1] 28.2 [8.3] 2.7	40.7 [11.9] 36.8 [10.8] 2.8	40.0 [11.7] 35.1 [10.3] 2.8	38.9 [11.4] 32.6 [9.6] 2.7
	95 [35]	Total BTUH [kW] Sens BTUH [kW] Power	44.7 [13.1] 25.8 [7.6] 3.0	43.9 [12.9] 24.6 [7.2] 3.0	42.7 [12.5] 22.9 [6.7] 2.9	41.8 [12.3] 31.1 [9.1] 3.0	41.1 [12.0] 29.7 [8.7] 3.0	39.9 [11.7] 27.6 [8.1] 2.9	39.3 [11.5] 36.0 [10.5] 3.0	38.6 [11.3] 34.4 [10.1] 2.9	37.5 [11.0] 31.9 [9.4] 2.9
	100 [37.8]	Total BTUH [kW] Sens BTUH [kW] Power	43.3 [12.7] 25.0 [7.3] 3.2	42.5 [12.4] 23.9 [7.0] 3.2	41.3 [12.1] 22.1 [6.5] 3.1	40.4 [11.8] 30.3 [8.9] 3.2	39.7 [11.6] 28.9 [8.5] 3.1	38.6 [11.3] 26.9 [7.9] 3.1	37.9 [11.1] 35.2 [10.3] 3.2	37.2 [10.9] 33.6 [9.9] 3.1	36.2 [10.6] 31.2 [9.1] 3.1
	105 [40.6]	Total BTUH [kW] Sens BTUH [kW] Power	41.8 [12.2] 24.1 [7.1] 3.4	41.0 [12.0] 23.1 [6.8] 3.4	39.9 [11.7] 21.4 [6.3] 3.3	38.9 [11.4] 29.4 [8.6] 3.4	38.2 [11.2] 28.1 [8.2] 3.3	37.2 [10.9] 26.1 [7.7] 3.3	36.4 [10.7] 34.4 [10.1] 3.4	35.8 [10.5] 32.8 [9.6] 3.3	34.8 [10.2] 30.5 [8.9] 3.3
	110 [43.3]	Total BTUH [kW] Sens BTUH [kW] Power	40.3 [11.8] 23.3 [6.8] 3.6	39.6 [11.6] 22.2 [6.5] 3.6	38.5 [11.3] 20.6 [6.0] 3.5	37.4 [11.0] 28.6 [8.4] 3.6	36.8 [10.8] 27.3 [8.0] 3.5	35.7 [10.5] 25.3 [7.4] 3.5	34.9 [10.2] 33.5 [9.8] 3.6	34.3 [10.1] 32.0 [9.4] 3.5	33.3 [9.8] 29.7 [8.7] 3.5
	115 [46.1]	Total BTUH [kW] Sens BTUH [kW] Power	38.7 [11.4] 22.3 [6.5] 3.8	38.0 [11.1] 21.4 [6.3] 3.8	37.0 [10.8] 19.8 [5.8] 3.7	35.9 [10.5] 27.7 [8.1] 3.8	35.3 [10.3] 26.4 [7.7] 3.8	34.3 [10.0] 24.5 [7.2] 3.7	33.4 [9.8] 32.6 [9.5] 3.8	32.8 [9.6] 31.1 [9.1] 3.7	31.9 [9.3] 28.9 [8.5] 3.7
	120 [48.9]	Total BTUH [kW] Sens BTUH [kW] Power	37.2 [10.9] 21.4 [6.3] 4.0	36.5 [10.7] 20.4 [6.0] 4.0	35.5 [10.4] 19.0 [5.6] 3.9	34.3 [10.1] 26.7 [7.8] 4.0	33.7 [9.9] 25.5 [7.5] 4.0	32.8 [9.6] 23.7 [6.9] 3.9	31.8 [9.3] 31.6 [9.3] 4.0	31.2 [9.2] 30.2 [8.9] 4.0	30.4 [8.9] 28.0 [8.2] 3.9
	125 [51.7]	Total BTUH [kW] Sens BTUH [kW] Power	35.6 [10.4] 20.4 [6.0] 4.3	34.9 [10.2] 19.5 [5.7] 4.2	33.9 [9.9] 18.1 [5.3] 4.2	32.7 [9.6] 25.7 [7.5] 4.3	32.1 [9.4] 24.6 [7.2] 4.2	31.2 [9.2] 22.8 [6.7] 4.2	30.2 [8.8] 30.2 [8.8] 4.2	29.7 [8.7] 29.3 [8.6] 4.2	28.8 [8.4] 27.2 [8.0] 4.1

DR —Depression ratio  
dbE —Entering air dry bulb  
wbE—Entering air wet bulb

Total —Total capacity x 1000 BTUH  
Sens —Sensible capacity x 1000 BTUH  
Power —KW input

NOTES: ① When the entering air dry bulb is other than 80°F [27°C], adjust the sensible capacity from the table by adding [1.10 x CFM x (1 – DR) x (dbE – 80)].

[ ] Designates Metric Conversions







## GROSS SYSTEMS PERFORMANCE DATA—RGEA15048A

		ENTERING INDOOR AIR @ 80°F [26.7°C] dbE ①									
wbE		71°F [21.7°C]			67°F [19.4°C]			63°F [17.2°C]			
CFM [L/s]		1700 [802]	1550 [732]	1320 [623]	1700 [802]	1550 [732]	1320 [623]	1700 [802]	1550 [732]	1320 [623]	
DR ①		0.19	0.18	0.15	0.19	0.18	0.15	0.19	0.18	0.15	
OUTDOOR DRY BULB TEMPERATURE °F [°C]	75 [23.9]	Total BTUH [kW] Sens BTUH [kW] Power	58.3 [17.1] 33.2 [9.7] 2.7	57.3 [16.8] 31.8 [9.3] 2.6	55.8 [16.3] 29.6 [8.7] 2.6	54.6 [16.0] 39.2 [11.5] 2.7	53.7 [15.7] 37.5 [11.0] 2.6	52.2 [15.3] 34.9 [10.2] 2.6	51.6 [15.1] 44.7 [13.1] 2.6	50.7 [14.9] 42.8 [12.5] 2.6	49.3 [14.5] 39.8 [11.7] 2.6
	80 [26.7]	Total BTUH [kW] Sens BTUH [kW] Power	56.8 [16.7] 32.5 [9.5] 2.8	55.8 [16.4] 31.1 [9.1] 2.8	54.3 [15.9] 28.9 [8.5] 2.8	53.1 [15.6] 38.5 [11.3] 2.8	52.2 [15.3] 36.8 [10.8] 2.8	50.8 [14.9] 34.3 [10.0] 2.7	50.1 [14.7] 44.0 [12.9] 2.8	49.2 [14.4] 42.1 [12.3] 2.8	47.9 [14.0] 39.2 [11.5] 2.7
	85 [29.4]	Total BTUH [kW] Sens BTUH [kW] Power	55.3 [16.2] 31.7 [9.3] 3.0	54.3 [15.9] 30.3 [8.9] 2.9	52.8 [15.5] 28.2 [8.3] 2.9	51.5 [15.1] 37.7 [11.0] 2.9	50.6 [14.8] 36.0 [10.6] 2.9	49.3 [14.4] 33.6 [9.8] 2.9	48.5 [14.2] 43.2 [12.7] 2.9	47.7 [14.0] 41.3 [12.1] 2.9	46.4 [13.6] 38.4 [11.3] 2.9
	90 [32.2]	Total BTUH [kW] Sens BTUH [kW] Power	53.6 [15.7] 30.8 [9.0] 3.1	52.7 [15.4] 29.5 [8.6] 3.1	51.3 [15.0] 27.4 [8.0] 3.1	49.9 [14.6] 36.8 [10.8] 3.1	49.0 [14.4] 35.2 [10.3] 3.1	47.7 [14.0] 32.8 [9.6] 3.0	46.9 [13.7] 42.3 [12.4] 3.1	46.1 [13.5] 40.5 [11.9] 3.1	44.8 [13.1] 37.7 [11.0] 3.0
	95 [35]	Total BTUH [kW] Sens BTUH [kW] Power	51.9 [15.2] 29.9 [8.8] 3.3	51.0 [14.9] 28.6 [8.4] 3.3	49.6 [14.5] 26.6 [7.8] 3.2	48.2 [14.1] 35.9 [10.5] 3.3	47.3 [13.9] 34.3 [10.1] 3.3	46.1 [13.5] 32.0 [9.4] 3.2	45.2 [13.2] 41.4 [12.1] 3.3	44.4 [13.0] 39.6 [11.6] 3.3	43.2 [12.7] 36.8 [10.8] 3.2
	100 [37.8]	Total BTUH [kW] Sens BTUH [kW] Power	50.1 [14.7] 28.9 [8.5] 3.5	49.2 [14.4] 27.6 [8.1] 3.5	47.9 [14.0] 25.7 [7.5] 3.4	46.4 [13.6] 34.9 [10.2] 3.5	45.6 [13.4] 33.4 [9.8] 3.5	44.3 [13.0] 31.1 [9.1] 3.4	43.4 [12.7] 40.4 [11.8] 3.5	42.6 [12.5] 38.6 [11.3] 3.4	41.5 [12.2] 36.0 [10.5] 3.4
	105 [40.6]	Total BTUH [kW] Sens BTUH [kW] Power	48.2 [14.1] 27.8 [8.2] 3.7	47.4 [13.9] 26.6 [7.8] 3.7	46.1 [13.5] 24.8 [7.3] 3.6	44.5 [13.0] 33.8 [9.9] 3.7	43.7 [12.8] 32.4 [9.5] 3.7	42.6 [12.5] 30.1 [8.8] 3.6	41.5 [12.2] 39.3 [11.5] 3.7	40.8 [12.0] 37.6 [11.0] 3.7	39.7 [11.6] 35.0 [10.3] 3.6
	110 [43.3]	Total BTUH [kW] Sens BTUH [kW] Power	46.3 [13.6] 26.7 [7.8] 3.9	45.5 [13.3] 25.6 [7.5] 3.9	44.3 [13.0] 23.8 [7.0] 3.9	42.6 [12.5] 32.7 [9.6] 3.9	41.9 [12.3] 31.3 [9.2] 3.9	40.7 [11.9] 29.1 [8.5] 3.8	39.6 [11.6] 38.2 [11.2] 3.9	38.9 [11.4] 36.6 [10.7] 3.9	37.9 [11.1] 34.0 [10.0] 3.8
	115 [46.1]	Total BTUH [kW] Sens BTUH [kW] Power	44.3 [13.0] 25.5 [7.5] 4.2	43.5 [12.8] 24.4 [7.2] 4.2	42.4 [12.4] 22.7 [6.7] 4.1	40.6 [11.9] 31.6 [9.2] 4.2	39.9 [11.7] 30.2 [8.8] 4.1	38.8 [11.4] 28.1 [8.2] 4.1	37.6 [11.0] 37.1 [10.9] 4.2	36.9 [10.8] 35.5 [10.4] 4.1	35.9 [10.5] 33.0 [9.7] 4.1
	120 [48.9]	Total BTUH [kW] Sens BTUH [kW] Power	42.2 [12.4] 24.3 [7.1] 4.4	41.5 [12.2] 23.3 [6.8] 4.4	40.4 [11.8] 21.7 [6.3] 4.3	38.5 [11.3] 30.3 [8.9] 4.4	37.9 [11.1] 29.0 [8.5] 4.4	36.8 [10.8] 27.0 [7.9] 4.3	35.5 [10.4] 35.5 [10.4] 4.4	34.9 [10.2] 34.3 [10.0] 4.4	34.0 [10.0] 31.9 [9.3] 4.3
	125 [51.7]	Total BTUH [kW] Sens BTUH [kW] Power	40.1 [11.8] 23.0 [6.7] 4.7	39.4 [11.5] 22.0 [6.5] 4.7	38.3 [11.2] 20.5 [6.0] 4.6	36.4 [10.7] 29.0 [8.5] 4.7	35.7 [10.5] 27.8 [8.1] 4.6	34.8 [10.2] 25.9 [7.6] 4.6	33.4 [9.8] 33.4 [9.8] 4.7	32.8 [9.6] 32.8 [9.6] 4.6	31.9 [9.4] 30.8 [9.0] 4.6







# GROSS SYSTEMS PERFORMANCE DATA— RGEA15060A

		ENTERING INDOOR AIR @ 80°F [26.7°C] dbE ①									
wbE		71°F [21.7°C]			67°F [19.4°C]			63°F [17.2°C]			
CFM [L/s]		2040 [963]	1850 [873]	1570 [741]	2040 [963]	1850 [873]	1570 [741]	2040 [963]	1850 [873]	1570 [741]	
DR ①		0.15	0.14	0.11	0.15	0.14	0.11	0.15	0.14	0.11	
OUTDOOR DRY BULB TEMPERATURE °F [°C]	75 [23.9]	Total BTUH [kW] Sens BTUH [kW] Power	73.0 [21.4] 42.4 [12.4] 3.6	71.7 [21.0] 40.5 [11.9] 3.6	69.7 [20.4] 37.6 [11.0] 3.5	69.2 [20.3] 50.0 [14.6] 3.6	67.9 [19.9] 47.7 [14.0] 3.5	66.0 [19.3] 44.3 [13.0] 3.5	65.8 [19.3] 56.9 [16.7] 3.5	64.6 [18.9] 54.3 [15.9] 3.5	62.8 [18.4] 50.5 [14.8] 3.4
	80 [26.7]	Total BTUH [kW] Sens BTUH [kW] Power	70.9 [20.8] 41.3 [12.1] 3.8	69.6 [20.4] 39.4 [11.6] 3.7	67.7 [19.8] 36.6 [10.7] 3.7	67.1 [19.6] 48.8 [14.3] 3.7	65.8 [19.3] 46.6 [13.7] 3.7	64.0 [18.8] 43.3 [12.7] 3.6	63.7 [18.7] 55.8 [16.4] 3.7	62.5 [18.3] 53.2 [15.6] 3.7	60.8 [17.8] 49.5 [14.5] 3.6
	85 [29.4]	Total BTUH [kW] Sens BTUH [kW] Power	68.8 [20.2] 40.1 [11.8] 4.0	67.6 [19.8] 38.3 [11.2] 3.9	65.7 [19.3] 35.6 [10.4] 3.9	64.9 [19.0] 47.7 [14.0] 3.9	63.7 [18.7] 45.5 [13.3] 3.9	62.0 [18.2] 42.3 [12.4] 3.8	61.5 [18.0] 54.6 [16.0] 3.9	60.4 [17.7] 52.1 [15.3] 3.8	58.8 [17.2] 48.5 [14.2] 3.8
	90 [32.2]	Total BTUH [kW] Sens BTUH [kW] Power	66.7 [19.5] 38.9 [11.4] 4.2	65.4 [19.2] 37.2 [10.9] 4.1	63.6 [18.6] 34.5 [10.1] 4.1	62.8 [18.4] 46.5 [13.6] 4.1	61.6 [18.1] 44.3 [13.0] 4.1	59.9 [17.6] 41.2 [12.1] 4.0	59.4 [17.4] 53.4 [15.7] 4.1	58.3 [17.1] 51.0 [14.9] 4.0	56.7 [16.6] 47.4 [13.9] 4.0
	95 [35]	Total BTUH [kW] Sens BTUH [kW] Power	64.5 [18.9] 37.7 [11.0] 4.4	63.3 [18.5] 36.0 [10.5] 4.3	61.5 [18.0] 33.4 [9.8] 4.3	60.6 [17.7] 45.2 [13.3] 4.3	59.5 [17.4] 43.2 [12.6] 4.3	57.8 [16.9] 40.1 [11.8] 4.2	57.2 [16.8] 52.2 [15.3] 4.3	56.1 [16.5] 49.8 [14.6] 4.3	54.6 [16.0] 46.3 [13.6] 4.2
	100 [37.8]	Total BTUH [kW] Sens BTUH [kW] Power	62.2 [18.2] 36.4 [10.7] 4.6	61.1 [17.9] 34.7 [10.2] 4.6	59.4 [17.4] 32.3 [9.5] 4.5	58.3 [17.1] 43.9 [12.9] 4.6	57.3 [16.8] 41.9 [12.3] 4.5	55.7 [16.3] 39.0 [11.4] 4.5	55.0 [16.1] 50.9 [14.9] 4.5	54.0 [15.8] 48.6 [14.2] 4.5	52.5 [15.4] 45.1 [13.2] 4.4
	105 [40.6]	Total BTUH [kW] Sens BTUH [kW] Power	60.0 [17.6] 35.1 [10.3] 4.9	58.9 [17.3] 33.5 [9.8] 4.8	57.3 [16.8] 31.1 [9.1] 4.8	56.1 [16.4] 42.6 [12.5] 4.8	55.1 [16.1] 40.7 [11.9] 4.8	53.5 [15.7] 37.8 [11.1] 4.7	52.7 [15.4] 49.6 [14.5] 4.8	51.8 [15.2] 47.3 [13.9] 4.8	50.3 [14.7] 44.0 [12.9] 4.7
	110 [43.3]	Total BTUH [kW] Sens BTUH [kW] Power	57.7 [16.9] 33.7 [9.9] 5.2	56.6 [16.6] 32.2 [9.4] 5.1	55.1 [16.1] 29.9 [8.8] 5.0	53.8 [15.8] 41.2 [12.1] 5.1	52.8 [15.5] 39.3 [11.5] 5.1	51.4 [15.1] 36.6 [10.7] 5.0	50.4 [14.8] 48.2 [14.1] 5.1	49.5 [14.5] 46.0 [13.5] 5.0	48.1 [14.1] 42.7 [12.5] 5.0
	115 [46.1]	Total BTUH [kW] Sens BTUH [kW] Power	55.4 [16.2] 32.3 [9.5] 5.4	54.4 [15.9] 30.8 [9.0] 5.4	52.9 [15.5] 28.6 [8.4] 5.3	51.5 [15.1] 39.8 [11.7] 5.4	50.5 [14.8] 38.0 [11.1] 5.4	49.2 [14.4] 35.3 [10.3] 5.3	48.1 [14.1] 46.8 [13.7] 5.4	47.2 [13.8] 44.6 [13.1] 5.3	45.9 [13.5] 41.5 [12.2] 5.2
	120 [48.9]	Total BTUH [kW] Sens BTUH [kW] Power	53.0 [15.5] 30.8 [9.0] 5.8	52.1 [15.3] 29.4 [8.6] 5.7	50.6 [14.8] 27.3 [8.0] 5.6	49.1 [14.4] 38.4 [11.2] 5.7	48.2 [14.1] 36.6 [10.7] 5.7	46.9 [13.7] 34.0 [10.0] 5.6	45.8 [13.4] 45.3 [13.3] 5.7	44.9 [13.2] 43.2 [12.7] 5.6	43.7 [12.8] 40.2 [11.8] 5.5
	125 [51.7]	Total BTUH [kW] Sens BTUH [kW] Power	50.7 [14.8] 29.3 [8.6] 6.1	49.7 [14.6] 28.0 [8.2] 6.0	48.4 [14.2] 26.0 [7.6] 6.0	46.8 [13.7] 36.9 [10.8] 6.0	45.9 [13.5] 35.2 [10.3] 6.0	44.6 [13.1] 32.7 [9.6] 5.9	43.4 [12.7] 43.4 [12.7] 6.0	42.6 [12.5] 41.8 [12.3] 6.0	41.4 [12.1] 38.9 [11.4] 5.9

DR —Depression ratio  
dbE —Entering air dry bulb  
wbE—Entering air wet bulb

Total —Total capacity x 1000 BTUH  
Sens —Sensible capacity x 1000 BTUH  
Power —KW input

NOTES: ① When the entering air dry bulb is other than 80°F [27°C], adjust the sensible capacity from the table by adding  $[1.10 \times \text{CFM} \times (1 - \text{DR}) \times (\text{dbE} - 80)]$ .

[ ] Designates Metric Conversions





Air

Indoor Airflow Performance

RGEA14 Series

## INDOOR AIRFLOW PERFORMANCE RGEA14 - 208 VOLTS

Nominal Cooling Capacity Tons [kW]	Motor Speed from Factory		Heating Input BTU/HR [kW]	Manufacturer Recommended Cooling Airflow (Min/Max)	Blower Size/ Motor HP [W] & # of Speeds	Motor Speed / Tap	External Static Pressure - Inches W.C. [kPa]											
	Cool	Heat					0.1 [0.2]	0.2 [0.05]	0.3 [0.07]	0.4 [0.10]	0.5 [0.12]	0.6 [0.15]	0.7 [0.17]	0.8 [0.20]	0.9 [0.22]	1.0 [0.25]		
2.0 [7.03]	High	High	40,000 [11.72]	700 CFM / 950 CFM	9x7 Blower 1/4 HP [186] 2 Speed (PSC Motor)	Low	CFM	706 [333]	685 [323]	661 [312]	614 [290]	523 [247]	437 [206]	334 [158]				
		RPM	844				886	943	989	1036	1067	1095						
2.5 [8.79]	Low	High	60,000 [17.58]	850 CFM / 1150 CFM	10x9 Blower 1/2 HP [372] 3 Speed (PSC Motor)	Med	CFM	925 [437]	874 [412]	813 [384]	763 [360]	681 [321]	534 [252]	441 [208]				
		RPM	1004				1027	1058	1070	1091	1116	1128						
3.0 [10.55]	High	High	80,000 [23.45]	1000 CFM / 1400 CFM	12x9T Blower 1/2 HP [372] 2 Speed (PSC Motor)	High	CFM	967 [456]	947 [447]	892 [421]	813 [384]	740 [349]	681 [321]	613 [289]	504 [238]			
		RPM	819				876	916	966	995	1018	1040	1066					
3.5 [12.31]	Tap 5	High	80,000 [23.45] 100,000 [29.31]	1200 CFM / 1600 CFM	12x9T Blower 3/4 HP [559] 5 Speed (Constant Torque)	Tap 5 High Static Cool	CFM	1119 [528]	1081 [510]	1029 [486]	968 [457]	851 [402]	774 [365]	699 [330]	613 [289]			
		RPM	891				930	965	995	1026	1047	1059	1078					
3.0 [10.55]	High	High	80,000 [23.45] 100,000 [29.31]	1000 CFM / 1400 CFM	12x9T Blower 1/2 HP [372] 2 Speed (PSC Motor)	High	CFM	1311 [619]	1249 [589]	1168 [551]	1089 [514]	985 [465]	861 [406]	779 [368]	699 [330]			
		RPM	1010				1031	1046	1066	1080	1095	1106	1113					
3.0 [10.55]	High	High	80,000 [23.45] 100,000 [29.31]	1000 CFM / 1400 CFM	12x9T Blower 1/2 HP [372] 2 Speed (PSC Motor)	High	CFM	458	437	409	387	360	332	314	300			
		RPM	458				437	409	387	360	332	314	300					
3.0 [10.55]	High	High	80,000 [23.45] 100,000 [29.31]	1000 CFM / 1400 CFM	12x9T Blower 1/2 HP [372] 2 Speed (PSC Motor)	High	CFM	1163 [549]	1115 [526]	1075 [507]	1012 [478]	926 [437]	841 [397]	753 [355]	647 [305]			
		RPM	771				804	844	870	910	932	968	992					
3.0 [10.55]	High	High	80,000 [23.45] 100,000 [29.31]	1000 CFM / 1400 CFM	12x9T Blower 1/2 HP [372] 2 Speed (PSC Motor)	High	CFM	392	387	380	367	356	345	330	316			
		RPM	392				387	380	367	356	345	330	316					
3.0 [10.55]	High	High	80,000 [23.45] 100,000 [29.31]	1000 CFM / 1400 CFM	12x9T Blower 1/2 HP [372] 2 Speed (PSC Motor)	High	CFM	1543 [728]	1484 [700]	1422 [671]	1345 [635]	1251 [590]	1177 [555]	1071 [505]	939 [443]			
		RPM	939				957	975	1345	1251	1177	1037	1051					
3.0 [10.55]	High	High	80,000 [23.45] 100,000 [29.31]	1000 CFM / 1400 CFM	12x9T Blower 1/2 HP [372] 2 Speed (PSC Motor)	High	CFM	586	572	555	522	495	468	441	414			
		RPM	586				572	555	522	495	468	441	414					
3.0 [10.55]	High	High	80,000 [23.45] 100,000 [29.31]	1000 CFM / 1400 CFM	12x9T Blower 1/2 HP [372] 2 Speed (PSC Motor)	High	CFM	1346 [635]	1304 [615]	1264 [597]	1232 [581]	1185 [559]	1139 [538]	1092 [515]	1048 [495]			
		RPM	819				850	883	906	944	972	1014	1047					
3.0 [10.55]	High	High	80,000 [23.45] 100,000 [29.31]	1000 CFM / 1400 CFM	12x9T Blower 1/2 HP [372] 2 Speed (PSC Motor)	High	CFM	291	302	310	319	333	338	353	362			
		RPM	291				302	310	319	333	338	353	362					
3.0 [10.55]	High	High	80,000 [23.45] 100,000 [29.31]	1000 CFM / 1400 CFM	12x9T Blower 1/2 HP [372] 2 Speed (PSC Motor)	High	CFM	1346 [635]	1304 [615]	1264 [597]	1232 [581]	1185 [559]	1139 [538]	1092 [515]	1048 [495]			
		RPM	819				850	883	906	944	972	1014	1047					
3.0 [10.55]	High	High	80,000 [23.45] 100,000 [29.31]	1000 CFM / 1400 CFM	12x9T Blower 1/2 HP [372] 2 Speed (PSC Motor)	High	CFM	291	302	310	319	333	338	353	362			
		RPM	291				302	310	319	333	338	353	362					
3.0 [10.55]	High	High	80,000 [23.45] 100,000 [29.31]	1000 CFM / 1400 CFM	12x9T Blower 1/2 HP [372] 2 Speed (PSC Motor)	High	CFM	1411 [666]	1375 [649]	1343 [634]	1315 [621]	1269 [599]	1242 [586]	1203 [568]	1133 [535]			
		RPM	862				886	915	951	975	1011	1025	1074					
3.0 [10.55]	High	High	80,000 [23.45] 100,000 [29.31]	1000 CFM / 1400 CFM	12x9T Blower 1/2 HP [372] 2 Speed (PSC Motor)	High	CFM	340	345	356	371	380	393	397	413			
		RPM	340				345	356	371	380	393	397	413					
3.0 [10.55]	High	High	80,000 [23.45] 100,000 [29.31]	1000 CFM / 1400 CFM	12x9T Blower 1/2 HP [372] 2 Speed (PSC Motor)	High	CFM	1346 [635]	1304 [615]	1264 [597]	1232 [581]	1185 [559]	1139 [538]	1092 [515]	1048 [495]			
		RPM	819				850	883	906	944	972	1014	1047					
3.0 [10.55]	High	High	80,000 [23.45] 100,000 [29.31]	1000 CFM / 1400 CFM	12x9T Blower 1/2 HP [372] 2 Speed (PSC Motor)	High	CFM	291	302	310	319	333	338	353	362			
		RPM	291				302	310	319	333	338	353	362					
3.0 [10.55]	High	High	80,000 [23.45] 100,000 [29.31]	1000 CFM / 1400 CFM	12x9T Blower 1/2 HP [372] 2 Speed (PSC Motor)	High	CFM	1596 [753]	1547 [730]	1520 [717]	1499 [707]	1471 [694]	1421 [671]	1383 [653]	1332 [629]			
		RPM	940				973	988	1020	1038	1068	1102	1122					
3.0 [10.55]	High	High	80,000 [23.45] 100,000 [29.31]	1000 CFM / 1400 CFM	12x9T Blower 1/2 HP [372] 2 Speed (PSC Motor)	High	CFM	461	475	484	497	503	516	527	531			
		RPM	461				475	484	497	503	516	527	531					

Note: Set 3-1/2 through 5 ton Cool to Tap 4 for AHRI rated performance

[ ] Designates Metric Conversions



# INDOOR AIRFLOW PERFORMANCE RGEA14 - 208 VOLTS (continued)

Nominal Cooling Capacity Tons [kW]	Motor Speed from Factory		Heating Input BTU/HR [kW]	Manufacturer Recommended Cooling Airflow (Min/Max)	Blower Size/ Motor HP [W] & # of Speeds	Motor Speed / Tap	External Static Pressure - Inches W.C. [kPa] (Side Discharge-Dry Coil)										
	Cool	Heat					0.1 [0.02]	0.2 [0.05]	0.3 [0.07]	0.4 [0.10]	0.5 [0.12]	0.6 [0.15]	0.7 [0.17]	0.8 [0.20]	0.9 [0.22]	1.0 [0.25]	
4.0 [14.07]	Tap 5	Tap 2	80,000 [23.45]	1350 CFM / 1850 CFM	12x9T Blower 3/4 HP [559] 5 Speed (Constant Torque)	Tap 1 Unused	CFM	1367 [645]	1327 [626]	1299 [613]	1248 [589]	1203 [568]	1162 [548]	1127 [532]	1064 [502]	965 [455]	902 [426]
							RPM	744	778	813	843	873	910	938	985	1030	1058
							Watts	247	260	271	277	289	301	311	323	340	347
							CFM	1367 [645]	1327 [626]	1299 [613]	1248 [589]	1203 [568]	1162 [548]	1127 [532]	1064 [502]	965 [455]	902 [426]
							RPM	744	778	813	843	873	910	938	985	1030	1058
4.0 [14.07]	Tap 5	Tap 3	100,000 [29.31]	1350 CFM / 1850 CFM	12x9T Blower 3/4 HP [559] 5 Speed (Constant Torque)	Tap 3 100K	CFM	1452 [665]	1402 [662]	1367 [645]	1327 [626]	1283 [606]	1247 [589]	1205 [569]	1183 [558]	1103 [521]	1007 [475]
							RPM	778	808	839	870	895	930	962	993	1035	1078
							Watts	287	295	306	320	324	337	349	360	374	388
							CFM	1652 [780]	1621 [765]	1583 [747]	1539 [726]	1512 [714]	1478 [698]	1422 [671]	1408 [665]	1354 [639]	1332 [629]
							RPM	870	895	919	949	969	1000	1032	1049	1071	1107
5.0 [17.59]	Tap 5	Tap 1	100,000 [29.31]	1600 CFM / 2100 CFM	12x9R Blower 1 HP [746] 5 Speed (Constant Torque)	Tap 1 100K Heat	CFM	1442 [681]	1409 [665]	1344 [634]	1341 [633]	1291 [609]	1227 [579]	1199 [566]	1136 [536]	1065 [503]	1006 [475]
							RPM	823	843	872	883	916	944	968	997	1035	1059
							Watts	318	330	337	341	354	364	373	381	396	404
							CFM	1235 [583]	1184 [559]	1106 [522]	1078 [509]	1021 [482]	957 [452]	897 [423]	843 [398]	791 [373]	742 [350]
							RPM	733	765	811	828	866	895	929	954	977	1005
5.0 [17.59]	Tap 5	Tap 3	100,000 [29.31]	1600 CFM / 2100 CFM	12x9R Blower 1 HP [746] 5 Speed (Constant Torque)	Tap 3 Low Cool	CFM	1738 [820]	1680 [793]	1663 [785]	1626 [767]	1603 [757]	1554 [733]	1503 [709]	1445 [682]	1432 [676]	1386 [654]
							RPM	933	969	979	1001	1021	1045	1066	1100	1104	1125
							Watts	505	526	529	541	545	562	567	585	586	593
							CFM	1884 [889]	1882 [888]	1841 [869]	1801 [850]	1760 [831]	1680 [793]	1651 [779]	1584 [748]	1508 [712]	1428 [674]
							RPM	999	1014	1048	1064	1072	1105	1121	1131	1142	1147
5.0 [17.59]	Tap 5	Tap 4	100,000 [29.31]	1600 CFM / 2100 CFM	12x9R Blower 1 HP [746] 5 Speed (Constant Torque)	Tap 4 Med Cool	CFM	2081 [982]	1969 [929]	2001 [944]	1960 [925]	1896 [895]	1818 [858]	1764 [833]	1664 [785]	1593 [752]	1499 [707]
							RPM	1050	1102	1095	1104	1115	1126	1130	1140	1143	1147
							Watts	790	815	819	813	793	772	749	725	699	663
							CFM	1884 [889]	1882 [888]	1841 [869]	1801 [850]	1760 [831]	1680 [793]	1651 [779]	1584 [748]	1508 [712]	1428 [674]
							RPM	999	1014	1048	1064	1072	1105	1121	1131	1142	1147
5.0 [17.59]	Tap 5	Tap 5	100,000 [29.31]	1600 CFM / 2100 CFM	12x9R Blower 1 HP [746] 5 Speed (Constant Torque)	Tap 5 High Cool	CFM	2081 [982]	1969 [929]	2001 [944]	1960 [925]	1896 [895]	1818 [858]	1764 [833]	1664 [785]	1593 [752]	1499 [707]
							RPM	1050	1102	1095	1104	1115	1126	1130	1140	1143	1147
							Watts	790	815	819	813	793	772	749	725	699	663
							CFM	1884 [889]	1882 [888]	1841 [869]	1801 [850]	1760 [831]	1680 [793]	1651 [779]	1584 [748]	1508 [712]	1428 [674]
							RPM	999	1014	1048	1064	1072	1105	1121	1131	1142	1147

Note: Set 3-1/2 through 5 ton Cool to Tap 4 for AHRI rated performance

DOWN DISCHARGE PRESSURE DROP (ADD TO EXTERNAL STATIC PRESSURE)							
CFM [L/s]	800 [378]	1000 [472]	1200 [566]	1400 [661]	1600 [755]	1800 [849]	2000 [944]
Pressure Drop—Includes W.C. [kPa]	.02 [0.005]	.05 [0.012]	.07 [0.017]	.1 [0.025]	.12 [0.030]	.15 [0.037]	.17 [0.042]

[ ] Designates Metric Conversions



# INDOOR AIRFLOW PERFORMANCE RGEA14 - 230 VOLTS

Nominal Cooling Capacity Tons [kW]	Motor Speed from Factory		Heating Input BTU/HR [kW]	Manufacturer Recommended Cooling Airflow (Min/Max)	Blower Size/ Motor HP [W] & # of Speeds	Motor Speed / Tap	External Static Pressure - Inches W.C. [kPa] (Side Discharge-Dry Coil)													
	Cool	Heat					0.1 [0.2]	0.2 [0.05]	0.3 [0.07]	0.4 [0.10]	0.5 [0.12]	0.6 [0.15]	0.7 [0.17]	0.8 [0.20]	0.9 [0.22]	1.0 [0.25]				
2.0 [7.03]	High	High	40,000 [11.72]	700 CFM / 950 CFM	9x7 Blower 1/4 HP [186] 2 Speed (PSC Motor)	Low	CFM	822 [388]	789 [372]	750 [354]	696 [328]	624 [294]	496 [234]	402 [190]						
		Watts	917				954	994	1031	1051	1075	1105								
2.5 [8.79]	Low	High	60,000 [17.58]	850 CFM / 1150 CFM	10x9 Blower 1/2 HP [372] 3 Speed (PSC Motor)	Med	CFM	992 [468]	928 [438]	873 [412]	810 [382]	741 [350]	659 [311]	490 [231]						
		RPM	1055				1068	1080	1096	1106	1119	1136								
3.0 [10.55]	High	High	80,000 [23.45]	1000 CFM / 1400 CFM	12x9T Blower 1/2 HP [372] 2 Speed (PSC Motor)	High	CFM	271	256	245	227	214	199	175						
		Watts	900				935	969	999	1030	1053	1064	1082							
3.5 [12.31]	Tap 5	Tap 3	100,000 [29.31]	1200 CFM / 1600 CFM	12x9T Blower 3/4 HP [559] 5 Speed (Constant Torque)	Tap 5 High Static Cool	CFM	1083 [516]	1062 [501]	1001 [472]	930 [439]	815 [385]	728 [344]	663 [313]	571 [269]					
		RPM	900				935	969	999	1030	1053	1064	1082							
3.5 [12.31]	Tap 5	Tap 2	80,000 [23.45]	1200 CFM / 1600 CFM	12x9T Blower 3/4 HP [559] 5 Speed (Constant Torque)	Tap 2 Low Static Cool	CFM	900	875	855	835	815	795	775	755	735	715	695	675	655
		Watts	375				358	335	313	283	264	249	229							
3.5 [12.31]	Tap 5	Tap 1	80,000 [23.45]	1200 CFM / 1600 CFM	12x9T Blower 3/4 HP [559] 5 Speed (Constant Torque)	Tap 1 Unused	CFM	1239 [585]	1184 [559]	1114 [526]	1043 [492]	959 [453]	827 [390]	744 [351]	657 [310]					
		RPM	961				983	1006	1030	1052	1074	1084	1097							
3.5 [12.31]	Tap 5	Tap 4	100,000 [29.31]	1200 CFM / 1600 CFM	12x9T Blower 3/4 HP [559] 5 Speed (Constant Torque)	Tap 4 Low Static Cool	CFM	1049	1061	1073	1085	1097	1109	1116	1124					
		Watts	500				472	454	427	405	371	360	339							
3.5 [12.31]	Tap 5	Tap 3	100,000 [29.31]	1200 CFM / 1600 CFM	12x9T Blower 3/4 HP [559] 5 Speed (Constant Torque)	Tap 3 100K	CFM	1310 [618]	1246 [588]	1186 [560]	1128 [532]	1038 [490]	955 [451]	847 [400]	738 [348]					
		RPM	834				867	895	918	949	971	989	1019							
3.5 [12.31]	Tap 5	Tap 2	80,000 [23.45]	1200 CFM / 1600 CFM	12x9T Blower 3/4 HP [559] 5 Speed (Constant Torque)	Tap 2 80K	CFM	460	447	435	424	407	396	380	362					
		Watts	298				283	264	249	229										
3.5 [12.31]	Tap 5	Tap 1	80,000 [23.45]	1200 CFM / 1600 CFM	12x9T Blower 3/4 HP [559] 5 Speed (Constant Torque)	Tap 1 Unused	CFM	1644 [776]	1568 [740]	1488 [702]	1421 [671]	1330 [628]	1248 [589]	1133 [535]	1003 [473]					
		RPM	981				996	1009	1021	1030	1048	1058	1072							
3.5 [12.31]	Tap 5	Tap 5	100,000 [29.31]	1200 CFM / 1600 CFM	12x9T Blower 3/4 HP [559] 5 Speed (Constant Torque)	Tap 5 High Static Cool	CFM	664	641	620	600	580	560	540	520					
		Watts	298				283	264	249	229										
3.5 [12.31]	Tap 5	Tap 4	100,000 [29.31]	1200 CFM / 1600 CFM	12x9T Blower 3/4 HP [559] 5 Speed (Constant Torque)	Tap 4 Low Static Cool	CFM	827	856	874	913	949	983	1013	1048					
		RPM	827				856	874	913	949	983	1013	1048							
3.5 [12.31]	Tap 5	Tap 3	100,000 [29.31]	1200 CFM / 1600 CFM	12x9T Blower 3/4 HP [559] 5 Speed (Constant Torque)	Tap 3 100K	CFM	1336 [631]	1312 [619]	1295 [611]	1241 [586]	1200 [566]	1161 [548]	1119 [528]	1072 [506]					
		RPM	827				856	874	913	949	983	1013	1048							
3.5 [12.31]	Tap 5	Tap 2	80,000 [23.45]	1200 CFM / 1600 CFM	12x9T Blower 3/4 HP [559] 5 Speed (Constant Torque)	Tap 2 80K	CFM	298	308	313	325	341	352	361	374					
		Watts	298				308	313	325	341	352	361	374							
3.5 [12.31]	Tap 5	Tap 1	80,000 [23.45]	1200 CFM / 1600 CFM	12x9T Blower 3/4 HP [559] 5 Speed (Constant Torque)	Tap 1 Unused	CFM	1453 [686]	1424 [672]	1395 [658]	1347 [636]	1321 [623]	1279 [604]	1250 [590]	1214 [573]					
		RPM	836				867	904	942	953	992	1019	1048							
3.5 [12.31]	Tap 5	Tap 5	100,000 [29.31]	1200 CFM / 1600 CFM	12x9T Blower 3/4 HP [559] 5 Speed (Constant Torque)	Tap 5 High Static Cool	CFM	334	349	364	377	380	394	409	418					
		Watts	334				349	364	377	380	394	409	418							
3.5 [12.31]	Tap 5	Tap 4	100,000 [29.31]	1200 CFM / 1600 CFM	12x9T Blower 3/4 HP [559] 5 Speed (Constant Torque)	Tap 4 Low Static Cool	CFM	1336 [631]	1312 [619]	1295 [611]	1241 [586]	1200 [566]	1161 [548]	1119 [528]	1072 [506]					
		RPM	827				856	874	913	949	983	1013	1048							
3.5 [12.31]	Tap 5	Tap 3	100,000 [29.31]	1200 CFM / 1600 CFM	12x9T Blower 3/4 HP [559] 5 Speed (Constant Torque)	Tap 3 100K	CFM	1591 [751]	1563 [738]	1558 [735]	1519 [717]	1490 [703]	1458 [688]	1410 [665]	1363 [643]					
		RPM	949				981	999	1027	1051	1086	1109	1129							
3.5 [12.31]	Tap 5	Tap 2	80,000 [23.45]	1200 CFM / 1600 CFM	12x9T Blower 3/4 HP [559] 5 Speed (Constant Torque)	Tap 2 80K	CFM	476	490	501	515	527	542	546	543					
		Watts	476				490	501	515	527	542	546	543							

Note: Set 3-1/2 through 5 ton Cool to Tap 4 for AHRI rated performance

[ ] Designates Metric Conversions



# INDOOR AIRFLOW PERFORMANCE RGEA14 - 230 VOLTS (continued)

Nominal Cooling Capacity Tons [kW]	Motor Speed from Factory		Heating Input BTU/HR [kW]	Manufacturer Recommended Cooling Airflow (Min/Max)	Blower Size/ Motor HP [W] & # of Speeds	Motor Speed / Tap	External Static Pressure - Inches W.C. [kPa] (Side Discharge-Dry Coil)									
	Cool	Heat					0.1 [0.02]	0.2 [0.05]	0.3 [0.07]	0.4 [0.10]	0.5 [0.12]	0.6 [0.15]	0.7 [0.17]	0.8 [0.20]	0.9 [0.22]	1.0 [0.25]
4.0 [14.07]	Tap 5		80,000 [23.45]	1350 CFM / 1850 CFM	12x9T Blower 3/4 HP [559] 5 Speed (Constant Torque)	Tap 1 Unused	CFM 1368 [646]	1331 [628]	1299 [613]	1259 [594]	1221 [576]	1169 [552]	1137 [537]	1079 [509]	997 [471]	920 [434]
						Tap 2 80K	RPM 749	782	813	849	877	911	946	979	1030	1061
						Tap 3 100K	Watts 250	264	275	286	295	308	321	327	346	356
						Tap 4 Low Static Cool	CFM 1368 [646]	1331 [628]	1299 [613]	1259 [594]	1221 [576]	1169 [552]	1137 [537]	1079 [509]	997 [471]	920 [434]
						Tap 5 High Static Cool	RPM 749	782	813	849	877	911	946	979	1030	1061
5.0 [17.59]	Tap 5		100,000 [29.31]	1600 CFM / 2100 CFM	12x9R Blower 1 HP [746] 5 Speed (Constant Torque)	Tap 1 100K Heat	CFM 1433 [676]	1407 [664]	1354 [639]	1329 [627]	1270 [599]	1235 [583]	1195 [564]	1137 [537]	1083 [511]	1030 [486]
						Tap 2 Unused	RPM 821	843	868	888	929	944	975	1004	1040	1065
						Tap 3 Low Cool	Watts 319	331	342	346	365	368	381	391	406	412
						Tap 4 Med Cool	CFM 1233 [582]	1158 [547]	1136 [536]	1090 [514]	1039 [490]	969 [457]	902 [426]	847 [400]	791 [373]	752 [355]
						Tap 5 High Cool	RPM 734	774	793	822	860	892	934	957	983	1011
						Watts 223	231	238	248	259	269	288	284	295	306	
						CFM 1788 [834]	1730 [816]	1693 [799]	1626 [767]	1599 [755]	1558 [735]	1522 [718]	1503 [709]	1444 [681]	1399 [660]	
						RPM 938	959	983	1011	1025	1052	1089	1090	1117	1134	
						Watts 520	533	541	560	563	578	599	599	605	615	
						CFM 1926 [909]	1890 [892]	1864 [880]	1822 [860]	1794 [847]	1758 [830]	1710 [807]	1670 [788]	1670 [788]	1579 [745]	1483 [705]
						RPM 999	1014	1040	1061	1079	1096	1119	1128	1138	1144	
						Watts 654	660	674	688	699	708	714	705	683	661	
						CFM 2096 [989]	2057 [971]	2003 [945]	1951 [921]	1890 [892]	1819 [858]	1756 [829]	1686 [796]	1610 [760]	1498 [707]	
						RPM 1069	1092	1106	1116	1121	1129	1138	1140	1148	1154	
						Watts 829	846	840	822	807	782	768	730	708	679	

Note: Set 3-1/2 through 5 ton Cool to Tap 4 for AHRI rated performance

DOWN DISCHARGE PRESSURE DROP (ADD TO EXTERNAL STATIC PRESSURE)						
CFM [L/s]	800 [378]	1000 [472]	1200 [566]	1400 [661]	1800 [849]	2000 [944]
Pressure Drop—Includes W.C. [kPa]	.02 [0.005]	.05 [0.012]	.07 [0.017]	.1 [0.025]	.15 [0.037]	.17 [0.042]

[ ] Designates Metric Conversions



# INDOOR AIRFLOW PERFORMANCE RGEA14 - 460 VOLTS

Nominal Cooling Capacity Tons [kW]	Motor Speed from Factory		Heating Input BTU/HR [kW]	Manufacturer Recommended Cooling Airflow (Min/Max)	Blower Size/ Motor HP [W] & # of Speeds	Motor Speed / Tap	External Static Pressure - Inches W.C. [kPa]										
	Cool	Heat					0.1 [0.2]	0.2 [0.05]	0.3 [0.07]	0.4 [0.10]	0.5 [0.12]	0.6 [0.15]	0.7 [0.17]	0.8 [0.20]	0.9 [0.22]	1.0 [0.25]	
3.0 [10.55]	High	Low	60,000 [17.58]	1000 CFM / 1400 CFM	12x9T Blower 1/2 HP [372] 2 Speed (PSC Motor)	Low	CFM	1358 [641]	1322 [624]	1266 [597]	1209 [571]	1120 [529]	1063 [502]	970 [458]	861 [406]	828 [391]	757 [357]
		RPM	823				849	901	932	953	979	999	1029	1055			
3.0 [10.55]	High	High	80,000 [23.45] 100,000 [29.31]	1000 CFM / 1400 CFM	12x9T Blower 1/2 HP [372] 2 Speed (PSC Motor)	High	CFM	1652 [780]	1596 [753]	1540 [727]	1481 [699]	1402 [662]	1320 [623]	1212 [572]	1132 [534]	1079 [509]	1004 [474]
		RPM	951				965	977	992	1007	1019	1036	1050	1063	1077		
3.0 [10.55]	High	High	80,000 [23.45]	1000 CFM / 1400 CFM	12x9T Blower 1/2 HP [372] 2 Speed (PSC Motor)	Tap 1 Unused	CFM	1362 [643]	1327 [626]	1294 [611]	1267 [598]	1207 [570]	1151 [543]	1131 [534]	1085 [512]	1022 [482]	956 [451]
		RPM	794				833	872	897	948	976	1005	1038	1078	1112		
3.5 [12.31]	Tap 5	Tap 2	80,000 [23.45]	1200 CFM / 1600 CFM	12x9T Blower 3/4 HP [559] 5 Speed (Constant Torque)	Tap 2 80K	CFM	1362 [643]	1327 [626]	1294 [611]	1267 [598]	1207 [570]	1151 [543]	1131 [534]	1085 [512]	1022 [482]	956 [451]
		RPM	794				833	872	897	948	976	1005	1038	1078	1112		
3.5 [12.31]	Tap 5	Tap 3	100,000 [29.31]	1200 CFM / 1600 CFM	12x9T Blower 3/4 HP [559] 5 Speed (Constant Torque)	Tap 3 100K	CFM	1435 [677]	1405 [663]	1378 [650]	1349 [637]	1309 [618]	1266 [597]	1233 [582]	1193 [563]	1134 [535]	1066 [503]
		RPM	844				867	892	927	961	991	1022	1052	1101	1130		
3.5 [12.31]	Tap 5	Tap 5	100,000 [29.31]	1200 CFM / 1600 CFM	12x9T Blower 3/4 HP [559] 5 Speed (Constant Torque)	Tap 4 Low Static Cool	CFM	1362 [643]	1327 [626]	1294 [611]	1267 [598]	1207 [570]	1151 [543]	1131 [534]	1085 [512]	1022 [482]	956 [451]
		RPM	794				833	872	897	948	976	1005	1038	1078	1112		
4.0 [14.07]	Tap 5	Tap 5	100,000 [29.31]	1350 CFM / 1850 CFM	12x9T Blower 3/4 HP [559] 5 Speed (Constant Torque)	Tap 5 High Static Cool	CFM	1643 [775]	1609 [759]	1580 [746]	1560 [736]	1511 [713]	1494 [705]	1443 [681]	1404 [663]	1335 [630]	1244 [587]
		RPM	927				954	986	1001	1035	1052	1083	1111	1122	1133		
4.0 [14.07]	Tap 5	Tap 5	100,000 [29.31]	1350 CFM / 1850 CFM	12x9T Blower 3/4 HP [559] 5 Speed (Constant Torque)	Tap 1 Unused	CFM	1340 [632]	1305 [616]	1263 [596]	1227 [579]	1186 [560]	1162 [548]	1104 [521]	1020 [481]	960 [453]	897 [423]
		RPM	776				796	831	869	898	925	966	1011	1044	1076		
4.0 [14.07]	Tap 5	Tap 2	80,000 [23.45]	1350 CFM / 1850 CFM	12x9T Blower 3/4 HP [559] 5 Speed (Constant Torque)	Tap 2 80K	CFM	1340 [632]	1305 [616]	1263 [596]	1227 [579]	1186 [560]	1162 [548]	1104 [521]	1020 [481]	960 [453]	897 [423]
		RPM	776				796	831	869	898	925	966	1011	1044	1076		
4.0 [14.07]	Tap 5	Tap 3	100,000 [29.31]	1350 CFM / 1850 CFM	12x9T Blower 3/4 HP [559] 5 Speed (Constant Torque)	Tap 4 Low Static Cool	CFM	1467 [692]	1448 [683]	1404 [663]	1373 [648]	1339 [632]	1306 [616]	1250 [590]	1210 [571]	1164 [549]	1087 [513]
		RPM	826				855	884	910	939	969	1003	1033	1067	1108		
4.0 [14.07]	Tap 5	Tap 5	100,000 [29.31]	1350 CFM / 1850 CFM	12x9T Blower 3/4 HP [559] 5 Speed (Constant Torque)	Tap 5 High Static Cool	CFM	1634 [771]	1595 [753]	1547 [730]	1530 [722]	1487 [702]	1462 [690]	1438 [679]	1378 [650]	1352 [638]	1298 [613]
		RPM	894				923	950	981	1000	1030	1051	1079	1106	1126		
4.0 [14.07]	Tap 5	Tap 5	100,000 [29.31]	1350 CFM / 1850 CFM	12x9T Blower 3/4 HP [559] 5 Speed (Constant Torque)	Tap 5 High Static Cool	CFM	1941 [916]	1915 [904]	1878 [886]	1814 [856]	1773 [837]	1709 [807]	1655 [781]	1570 [741]	1488 [702]	1374 [648]
		RPM	1028				1047	1068	1091	1104	1113	1124	1136	1142	1147		
4.0 [14.07]	Tap 5	Tap 5	100,000 [29.31]	1350 CFM / 1850 CFM	12x9T Blower 3/4 HP [559] 5 Speed (Constant Torque)	Tap 5 High Static Cool	CFM	708	725	729	727	717	696	673	647	618	571
		RPM	708				725	729	727	717	696	673	647	618	571		

Note: Set 3-1/2 through 5 ton Cool to Tap 4 for AHRI rated performance

[ ] Designates Metric Conversions



# INDOOR AIRFLOW PERFORMANCE RGEA14 - 460 VOLTS (continued)

Nominal Cooling Capacity Tons [kW]	Motor Speed from Factory		Heating Input BTU/HR [kW]	Manufacturer Recommended Cooling Airflow (Min/Max)	Blower Size/ Motor HP [W] & # of Speeds	Motor Speed / Tap	External Static Pressure - Inches W.C. [kPa] (Side Discharge-Dry Coil)										
	Cool	Heat					0.1 [.02]	0.2 [.05]	0.3 [.07]	0.4 [.10]	0.5 [.12]	0.6 [.15]	0.7 [1.17]	0.8 [1.20]	0.9 [.22]	1.0 [.25]	
5.0 [17.59]	Tap 5	Tap 1	100,000 [29.31]	1600 CFM / 2100 CFM	12x9R Blower 1 HP [746] 5 Speed (Constant Torque)	Tap 3 Low Cool	CFM	1484 [700]	1440 [680]	1405 [663]	1360 [642]	1319 [622]	1280 [604]	1238 [584]	1186 [560]	1128 [532]	1047 [494]
							RPM	812	841	863	889	918	938	965	994	1026	1066
							Watts	330	338	355	354	379	381	395	408	423	419
							CFM	1289 [608]	1239 [585]	1189 [561]	1140 [538]	1101 [520]	1052 [496]	969 [457]	918 [433]	860 [406]	812 [383]
							RPM	726	755	786	815	846	876	912	935	964	986
	Tap 4	Tap 1	100,000 [29.31]	1600 CFM / 2100 CFM	12x9R Blower 1 HP [746] 5 Speed (Constant Torque)	Tap 4 Med Cool	CFM	1787 [843]	1746 [824]	1705 [805]	1680 [793]	1621 [765]	1607 [758]	1564 [738]	1530 [722]	1505 [710]	1424 [672]
							RPM	950	970	1000	1012	1042	1055	1079	1108	1113	1130
							Watts	525	538	545	579	571	596	615	610	631	626
							CFM	1954 [922]	1927 [909]	1889 [892]	1843 [870]	1808 [853]	1738 [820]	1671 [789]	1620 [765]	1543 [728]	1433 [676]
							RPM	1030	1042	1061	1082	1100	1121	1130	1133	1138	1146
Tap 5	Tap 1	100,000 [29.31]	1600 CFM / 2100 CFM	12x9R Blower 1 HP [746] 5 Speed (Constant Torque)	Tap 5 High Cool	CFM	2095 [989]	2045 [965]	1983 [936]	1905 [899]	1840 [868]	1792 [846]	1712 [808]	1641 [774]	1558 [735]	1397 [659]	
						RPM	1103	1114	1114	1123	1125	1130	1139	1140	1144	1148	
						Watts	829	841	832	803	785	770	749	710	685	633	

Note: Set 3-1/2 through 5 ton Cool to Tap 4 for AHRI rated performance

## DOWN DISCHARGE PRESSURE DROP (ADD TO EXTERNAL STATIC PRESSURE)

CFM [L/s]	800 [378]	1000 [472]	1200 [566]	1400 [661]	1600 [755]	1800 [849]	2000 [944]
Pressure Drop—Includes W.C. [kPa]	.02 [.005]	.05 [.012]	.07 [.017]	.1 [.025]	.12 [.030]	.15 [.037]	.17 [.042]

[ ] Designates Metric Conversions



Air

Indoor Airflow Performance  
RGEA15 Series







Air

Indoor Airflow Performance

RGEA15 Series

## INDOOR AIRFLOW PERFORMANCE RGEA15 - 208/230 VOLTS

Nominal Cooling Capacity Tons [kW]	Blower Size/ Motor HP [W] & Motor Type	Nominal Heating Capacity BTU/HR [kW]	Motor Speed	External Static Pressure - Inches W.C. [kPa] (Side Discharge-Dry Coil)										
				0.1 [0.02]	0.2 [0.05]	0.3 [0.07]	0.4 [1.10]	0.5 [1.12]	0.6 [1.15]	0.7 [1.17]	0.8 [1.20]	0.9 [1.22]	1.0 [1.25]	
2.0 [7.03]	10 x 9 Blower 1/2 HP [372 W] ECM	60,000 [17.58]	Heat	CFM	766 [362]	773 [365]	771 [364]	770 [363]	768 [362]	757 [357]	751 [354]	742 [350]	726 [343]	715 [337]
				RPM	649	746	829	897	946	1000	1046	1088	1133	1170
				Watts	83	107	130	152	169	188	206	222	240	255
			Cool	CFM	891 [421]	902 [426]	910 [429]	906 [428]	912 [430]	906 [428]	903 [426]	891 [421]	876 [413]	868 [410]
				RPM	747	831	895	957	1017	1068	1111	1151	1186	1223
				Watts	123	152	176	200	225	247	268	288	302	321
	10 x 9 Blower 1/2 HP [372 W] ECM	80,000 [23.44]	Heat	CFM	1189 [561]	1198 [565]	1203 [568]	1210 [571]	1212 [572]	1208 [570]	1193 [563]	1194 [564]	1146 [541]	1072 [506]
				RPM	894	964	1008	1084	1142	1187	1234	1285	1301	1310
				Watts	236	273	299	344	378	411	441	477	475	446
			Cool	CFM	891 [421]	902 [426]	910 [429]	906 [428]	912 [430]	906 [428]	903 [426]	891 [421]	876 [413]	868 [410]
				RPM	747	831	895	957	1017	1068	1111	1151	1186	1223
				Watts	123	152	176	200	225	247	268	288	302	321
2.5 [8.79]	10 x 9 Blower 1/2 HP [372 W] ECM	60,000 [17.58]	Heat	CFM	766 [362]	773 [365]	771 [364]	770 [363]	768 [362]	757 [357]	751 [354]	742 [350]	726 [343]	715 [337]
				RPM	649	746	829	897	946	1000	1046	1088	1133	1170
				Watts	83	107	130	152	169	188	206	222	240	255
			Cool	CFM	959 [453]	973 [459]	978 [462]	981 [463]	985 [465]	974 [460]	966 [456]	962 [454]	952 [449]	949 [448]
				RPM	772	855	922	990	1052	1100	1142	1184	1219	1256
				Watts	141	172	200	231	259	282	304	326	343	363
	10 x 9 Blower 1/2 HP [372 W] ECM	80,000 [23.44]	Heat	CFM	1189 [561]	1198 [565]	1203 [568]	1210 [571]	1212 [572]	1208 [570]	1193 [563]	1194 [564]	1146 [541]	1072 [506]
				RPM	894	964	1008	1084	1142	1187	1234	1285	1301	1310
				Watts	236	273	299	344	378	411	441	477	475	446
			Cool	CFM	959 [453]	973 [459]	978 [462]	981 [463]	985 [465]	974 [460]	966 [456]	962 [454]	952 [449]	949 [448]
				RPM	772	855	922	990	1052	1100	1142	1184	1219	1256
				Watts	141	172	200	231	259	282	304	326	343	363

Notes: (1) Set 2 through 4 ton Cool to Tap 4 for AHRI rated performance. (2) Set 5 ton 2nd Stage Cool to Tap 4 for AHRI rated performance.

[ ] Designates Metric Conversions





# INDOOR AIRFLOW PERFORMANCE RGEA15 - 208/230 VOLTS (continued)

Nominal Cooling Capacity Tons [kW]	Blower Size/ Motor HP [W] & Motor Type	Nominal Heating Capacity Btu/hr [kW]	Motor Speed	External Static Pressure - Inches W.C. [kPa] (Side Discharge-Dry Coil)																				
				0.1 [ .02]	0.2 [ .05]	0.3 [ .07]	0.4 [ .10]	0.5 [ .12]	0.6 [ .15]	0.7 [ .17]	0.8 [ .20]	0.9 [ .22]	1.0 [ .25]											
				CFM	RPM	Watts	CFM	RPM	Watts	CFM	RPM	Watts	CFM	RPM	Watts	CFM	RPM	Watts	CFM	RPM	Watts	CFM	RPM	Watts
3.0 [10.55]	10 x 9 Blower 1/2 HP [372 W] ECM	60,000 [17.58]	Heat	766 [362]	773 [365]	771 [364]	770 [363]	768 [362]	757 [357]	751 [354]	742 [350]	726 [343]	715 [337]	649	746	829	897	946	1000	1046	1088	1133	1170	
				83	107	130	152	169	188	206	222	240	255	1189 [561]	1199 [566]	1204 [568]	1206 [569]	1210 [571]	1202 [567]	1209 [571]	1165 [550]	1125 [531]	1061 [501]	
				908	964	1024	1094	1144	1195	1234	1269	1290	1307	247	278	311	354	385	421	448	457	454	446	
	3.0 [10.55]	10 x 9 Blower 3/4 HP [559 W] ECM	80,000 [23.44] & 100,000 [29.3]	Heat	1186 [560]	1191 [562]	1191 [562]	1199 [566]	1192 [563]	1182 [558]	1171 [553]	1156 [546]	1123 [530]	1045 [493]	904	974	1023	1077	1129	1174	1216	1263	1288	1292
					235	271	296	326	354	379	400	425	413	1194 [564]	1200 [566]	1208 [570]	1200 [566]	1190 [562]	1179 [556]	1128 [532]	1165 [550]	1128 [532]	1045 [493]	
					910	981	1027	1083	1134	1179	1219	1267	1294	239	276	300	332	359	384	405	435	428	414	
3.5 [12.31]	10 x 9 Blower 3/4 HP [559 W] ECM	80,000 [23.44] & 100,000 [29.3]	Heat	1206 [569]	1215 [573]	1219 [575]	1216 [574]	1218 [575]	1220 [576]	1216 [574]	1215 [573]	1205 [569]	1195 [564]	904	974	1023	1077	1129	1174	1216	1263	1288	1292	
				235	271	296	326	354	379	400	425	413	1296 [612]	1294 [611]	1299 [613]	1299 [613]	1294 [611]	1288 [608]	1275 [602]	1226 [579]	1141 [538]	1050 [496]		
				969	1035	1078	1133	1173	1220	1259	1302	1301	292	330	357	390	411	444	467	481	449	423		
	3.5 [12.31]	10 x 9 Blower 3/4 HP [559 W] ECM	80,000 [23.44] & 100,000 [29.3]	Cool	1206 [569]	1215 [573]	1219 [575]	1216 [574]	1218 [575]	1220 [576]	1216 [574]	1215 [573]	1205 [569]	1195 [564]	730	796	837	885	926	962	999	1038	1075	1112
					199	238	261	292	317	342	368	427	457	1535 [724]	1545 [729]	1551 [732]	1554 [733]	1553 [733]	1553 [733]	1551 [732]	1548 [731]	1543 [728]	1532 [723]	
					873	923	967	1005	1052	1096	1124	1180	1200	371	416	456	490	537	578	607	634	666	687	
4.0 [14.07]	12 x 9 Blower 1 HP [746 W] ECM	80,000 [23.44] & 100,000 [29.3]	Heat	1206 [569]	1215 [573]	1219 [575]	1216 [574]	1218 [575]	1220 [576]	1216 [574]	1215 [573]	1205 [569]	1195 [564]	730	796	837	885	926	962	999	1038	1075	1112	
				199	238	261	292	317	342	368	427	457	1535 [724]	1545 [729]	1551 [732]	1554 [733]	1553 [733]	1553 [733]	1551 [732]	1548 [731]	1543 [728]	1532 [723]		
				873	923	967	1005	1052	1096	1124	1180	1200	371	416	456	490	537	578	607	634	666	687		
	4.0 [14.07]	12 x 9 Blower 1 HP [746 W] ECM	100,000 [29.3]	Heat	1206 [569]	1215 [573]	1219 [575]	1216 [574]	1218 [575]	1220 [576]	1216 [574]	1215 [573]	1205 [569]	1195 [564]	730	796	837	885	926	962	999	1038	1075	1112
					199	238	261	292	317	342	368	427	457	1248 [589]	1256 [593]	1262 [596]	1261 [595]	1262 [596]	1264 [597]	1261 [595]	1261 [595]	1253 [591]	1243 [587]	
					749	808	853	903	942	979	1014	1086	1121	749	808	853	903	942	979	1014	1051	1086	1121	
5.0 [17.59]	12 x 9 Blower 1 HP [746 W] ECM	100,000 [29.3]	1st Stage Cool	218	254	281	315	341	369	394	422	481	218	254	281	315	341	369	394	422	452	481		
				1837 [867]	1850 [873]	1850 [873]	1853 [875]	1854 [875]	1847 [872]	1834 [866]	1834 [866]	1824 [861]	1818 [858]	997	1053	1094	1128	1164	1202	1225	1256	1283	1305	
				604	670	719	762	810	860	872	889	927	956	604	670	719	762	810	860	872	889	927	956	

Notes: (1) Set 2 through 4 ton Cool to Tap 4 for AHRI rated performance. (2) Set 5 ton 2nd Stage Cool to Tap 4 for AHRI rated performance.

[ ] Designates Metric Conversions



# INDOOR AIRFLOW PERFORMANCE RGEA15 - 460 VOLTS

Nominal Cooling Capacity Tons [kW]	Motor Speed from Factory		Heating Input BTU/HR [kW]	Manufacturer Recommended Cooling Airflow (Min/Max)	Blower Size/ Motor HP [W] & # of Speeds	Motor Speed / Tap	External Static Pressure - Inches W.C. [kPa]											
	Cool	Heat					0.1 [0.2]	0.2 [0.05]	0.3 [0.07]	0.4 [0.10]	0.5 [0.12]	0.6 [0.15]	0.7 [0.17]	0.8 [0.20]	0.9 [0.22]	1.0 [0.25]		
3.0 [10.55]	Tap 1	CFM	912 [430]	871 [411]	808 [381]	734 [346]	655 [309]	571 [269]	520 [245]	447 [211]								
		RPM	634	664	722	769	811	850	881	906								
		Watts	111	116	131	137	149	151	162	165								
	Tap 2	CFM	1362 [643]	1327 [626]	1294 [611]	1267 [598]	1207 [570]	1151 [543]	1131 [534]	1085 [512]	1022 [482]	956 [451]						
		RPM	794	833	872	897	948	976	1005	1038	1078	1112						
		Watts	287	295	317	317	331	351	361	370	399							
	Tap 3	CFM	1435 [677]	1405 [663]	1378 [650]	1349 [637]	1309 [618]	1266 [597]	1233 [582]	1193 [563]	1134 [535]	1066 [503]						
		RPM	844	867	892	927	961	991	1022	1052	1101	1130						
		Watts	337	340	358	368	390	389	409	411	438	446						
	Tap 4	CFM	1163 [549]	1144 [540]	1086 [513]	1073 [506]	987 [466]	927 [437]	870 [411]	819 [387]								
		RPM	749	761	810	836	887	920	964	1005								
		Watts	202	205	217	230	248	266	271									
	Tap 5	CFM	1435 [677]	1405 [663]	1378 [650]	1349 [637]	1309 [618]	1266 [597]	1233 [582]	1193 [563]	1134 [535]	1066 [503]						
		RPM	844	867	892	927	961	991	1022	1052	1101	1130						
		Watts	337	340	358	368	390	389	409	411	438	446						
3.5 [12.31]	Tap 1	CFM	1362 [643]	1327 [626]	1294 [611]	1267 [598]	1207 [570]	1151 [543]	1131 [534]	1085 [512]	1022 [482]	956 [451]						
		RPM	794	833	872	897	948	976	1005	1038	1078	1112						
		Watts	287	295	317	317	331	351	361	370	399							
	Tap 2	CFM	1362 [643]	1327 [626]	1294 [611]	1267 [598]	1207 [570]	1151 [543]	1131 [534]	1085 [512]	1022 [482]	956 [451]						
		RPM	794	833	872	897	948	976	1005	1038	1078	1112						
		Watts	287	295	317	317	331	351	361	370	399							
	Tap 3	CFM	1435 [677]	1405 [663]	1378 [650]	1349 [637]	1309 [618]	1266 [597]	1233 [582]	1193 [563]	1134 [535]	1066 [503]						
		RPM	844	867	892	927	961	991	1022	1052	1101	1130						
		Watts	337	340	358	368	390	389	409	411	438	446						
	Tap 4	CFM	1362 [643]	1327 [626]	1294 [611]	1267 [598]	1207 [570]	1151 [543]	1131 [534]	1085 [512]	1022 [482]	956 [451]						
		RPM	794	833	872	897	948	976	1005	1038	1078	1112						
		Watts	287	295	317	317	331	351	361	370	399							
	Tap 5	CFM	1435 [677]	1405 [663]	1378 [650]	1349 [637]	1309 [618]	1266 [597]	1233 [582]	1193 [563]	1134 [535]	1066 [503]						
		RPM	844	867	892	927	961	991	1022	1052	1101	1130						
		Watts	337	340	358	368	390	389	409	411	438	446						

Notes: (1) Set 2 through 4 ton Cool to Tap 4 for AHRI rated performance. (2) Set 5 ton 2nd Stage Cool to Tap 4 for AHRI rated performance.

[ J Designates Metric Conversions



# INDOOR AIRFLOW PERFORMANCE RGEA15 - 460 VOLTS (continued)

Nominal Cooling Capacity Tons [kW]	Motor Speed from Factory		Heating Input BTU/HR [kW]	Manufacturer Recommended Cooling Airflow (Min/Max)	Blower Size/ Motor HP [W] & # of Speeds	Motor Speed / Tap	External Static Pressure - Inches W.C. [kPa] (Side Discharge-Dry Coil)											
	Cool	Heat					0.1 [.02]	0.2 [.05]	0.3 [.07]	0.4 [.10]	0.5 [.12]	0.6 [.15]	0.7 [1.17]	0.8 [1.20]	0.9 [1.22]	1.0 [1.25]		
4.0 [14.07]	Tap 2	Cool	80,000 [23.45]	1350 CFM / 1850 CFM	12x9T Blower 3/4 HP [559] 5 Speed (Constant Torque)	Tap 1 Unused	CFM	1340 [632]	1305 [616]	1263 [596]	1227 [579]	1186 [560]	1162 [548]	1104 [521]	1020 [481]	960 [453]	897 [423]	
						RPM	776	796	831	869	898	925	966	1011	1044	1076		
						Watts	261	268	279	291	303	310	323	339	351	361		
						CFM	1340 [632]	1305 [616]	1263 [596]	1227 [579]	1186 [560]	1162 [548]	1104 [521]	1020 [481]	960 [453]	897 [423]		
						RPM	776	796	831	869	898	925	966	1011	1044	1076		
	Watts	261	268	279	291	303	310	323	339	351	361							
	Tap 3	Tap 5	Heat	100,000 [29.31]	1350 CFM / 1850 CFM	12x9T Blower 3/4 HP [559] 5 Speed (Constant Torque)	Tap 3 100K	CFM	1467 [692]	1448 [683]	1404 [663]	1373 [648]	1339 [632]	1306 [616]	1250 [590]	1210 [571]	1164 [549]	1087 [513]
	RPM	826	855				884	910	939	969	1003	1030	1067	1108				
	Watts	328	344				348	363	379	387	398	408	418	434				
	CFM	1634 [771]	1595 [753]				1547 [730]	1530 [722]	1487 [702]	1462 [690]	1438 [679]	1378 [650]	1352 [638]	1298 [613]				
RPM	894	923	950				981	1000	1030	1051	1079	1106	1126					
Watts	432	446	451	468	479	490	508	510	520	520								
5.0 [17.59]	1st Stage Tap 2	Cool	100,000 [29.31]	1600 CFM / 2100 CFM	12x9R Blower 1 HP [746] 5 Speed (Constant Torque)	Tap 1 100K Heat	CFM	1484 [700]	1440 [680]	1405 [663]	1360 [642]	1319 [622]	1280 [604]	1238 [584]	1186 [560]	1128 [532]	1047 [494]	
						RPM	812	841	863	889	918	938	965	994	1026	1066		
						Watts	330	338	355	354	379	381	395	408	423	419		
						CFM	1289 [608]	1239 [585]	1189 [561]	1140 [538]	1101 [520]	1052 [496]	969 [457]	918 [433]	860 [406]	812 [383]		
						RPM	726	755	786	815	846	876	912	935	964	986		
	Watts	233	248	249	259	275	292	309	308	321	330							
	Tap 1	2nd Stage Tap 5	Heat	100,000 [29.31]	1600 CFM / 2100 CFM	12x9R Blower 1 HP [746] 5 Speed (Constant Torque)	Tap 3 Unused	CFM	1787 [843]	1746 [824]	1705 [805]	1680 [793]	1621 [765]	1607 [758]	1564 [738]	1530 [722]	1505 [710]	1424 [672]
	RPM	950	970				1000	1012	1042	1055	1079	1108	1113	1130				
	Watts	525	538				545	579	571	596	615	610	631	626				
	CFM	1954 [922]	1927 [909]				1889 [892]	1843 [870]	1808 [853]	1738 [820]	1671 [789]	1620 [765]	1543 [728]	1433 [676]				
RPM	1030	1042	1061				1082	1100	1121	1130	1133	1138	1146					
Watts	664	673	683	696	704	700	697	684	667	635								
5.0 [17.59]	2nd Stage Tap 5	Heat	100,000 [29.31]	1600 CFM / 2100 CFM	12x9R Blower 1 HP [746] 5 Speed (Constant Torque)	Tap 5 High Static Cool	CFM	2095 [989]	2045 [965]	1983 [936]	1905 [899]	1840 [868]	1792 [846]	1712 [808]	1641 [774]	1558 [735]	1397 [659]	
						RPM	1103	1114	1114	1123	1125	1130	1139	1140	1144	1148		
						Watts	829	841	832	803	785	770	749	710	685	633		

Notes: (1) Set 2 through 4 ton Cool to Tap 4 for AHRI rated performance. (2) Set 5 ton 2nd Stage Cool to Tap 4 for AHRI rated performance.

DOWN DISCHARGE PRESSURE DROP (ADD TO EXTERNAL STATIC PRESSURE)			
CFM [L/s]	800 [378]	1000 [472]	2000 [944]
Pressure Drop—Includes W.C. [kPa]	.02 [.005]	.05 [.012]	.17 [.042]

[ J Designates Metric Conversions





ELECTRICAL DATA – RGEA14 SERIES									
		024AJD041AA	024AJD04XAA	024AJD061AA	024AJD06XAA	030AJD061AA	030AJD06XAA	030AJD081AA	030AJD08XAA
Unit Information	Unit Operating Voltage Range	187-253	187-253	187-253	187-253	187-253	187-253	187-253	187-253
	Volts	208/230	208/230	208/230	208/230	208/230	208/230	208/230	208/230
	Phase	1	1	1	1	1	1	1	1
	Hz	60	60	60	60	60	60	60	60
	Minimum Circuit Ampacity	17	17	17	17	20	20	20	20
	Minimum Overcurrent Protection Device Size	20	20	20	20	20	20	20	20
	Maximum Overcurrent Protection Device Size	25	25	25	25	30	30	30	30
Compressor Motor	No.	1	1	1	1	1	1	1	1
	Volts	208/230	208/230	208/230	208/230	208/230	208/230	208/230	208/230
	Phase	1	1	1	1	1	1	1	1
	RPM	3450	3450	3450	3450	3450	3450	3450	3450
	HP, Compressor 1	2 1/6	2 1/6	2 1/6	2 1/6	2 2/3	2 2/3	2 2/3	2 2/3
	Amps (RLA), Comp. 1	11.2	11.2	11.2	11.2	12.8	12.8	12.8	12.8
	Amps (LRA), Comp. 1	60.8	60.8	60.8	60.8	64	64	64	64
Condenser Motor	No.	1	1	1	1	1	1	1	1
	Volts	208/230	208/230	208/230	208/230	208/230	208/230	208/230	208/230
	Phase	1	1	1	1	1	1	1	1
	HP	1/3	1/3	1/3	1/3	1/3	1/3	1/3	1/3
	Amps (FLA, each)	1.5	1.5	1.5	1.5	1.5	1.5	1.5	1.5
	Amps (LRA, each)	3	3	3	3	3	3	3	3
Evaporator Fan	No.	1	1	1	1	1	1	1	1
	Volts	208/230	208/230	208/230	208/230	208/230	208/230	208/230	208/230
	Phase	1	1	1	1	1	1	1	1
	HP	1/4	1/4	1/4	1/4	1/2	1/2	1/2	1/2
	Amps (FLA, each)	1.3	1.3	1.3	1.3	2.4	2.4	2.4	2.4
	Amps (LRA, each)	2.3	2.3	2.3	2.3	5.1	5.1	5.1	5.1

1. Horsepower Per Compressor.
2. Amp Draw Per Motor. Multiply Value By Number of Motors to Determine Total Amps.



ELECTRICAL DATA – RGEA14 SERIES									
		036ACD061AA	036ACD081AA	036ACD101AA	036ADD061AA	036ADD081AA	036ADD101AA	036AJD061AA	036AJD06XAA
Unit Information	Unit Operating Voltage Range	187-253	187-253	187-253	414-506	414-506	414-506	187-253	187-253
	Volts	208/230	208/230	208/230	460	460	460	208/230	208/230
	Phase	3	3	3	3	3	3	1	1
	Hz	60	60	60	60	60	60	60	60
	Minimum Circuit Ampacity	16	16	16	9	9	9	22	22
	Minimum Overcurrent Protection Device Size	20	20	20	15	15	15	25	25
Maximum Overcurrent Protection Device Size	20	20	20	15	15	15	35	35	
Compressor Motor	No.	1	1	1	1	1	1	1	1
	Volts	208/230	208/230	208/230	460	460	460	208/230	208/230
	Phase	3	3	3	3	3	3	1	1
	RPM	3450	3450	3450	3450	3450	3450	3450	3450
	HP, Compressor 1	3 1/3	3 1/3	3 1/3	3 1/3	3 1/3	3 1/3	3 1/3	3 1/3
	Amps (RLA), Comp. 1	9	9	9	5.6	5.6	5.6	14.1	14.1
	Amps (LRA), Comp. 1	71	71	71	38	38	38	77	77
Condenser Motor	No.	1	1	1	1	1	1	1	1
	Volts	208/230	208/230	208/230	460	460	460	208/230	208/230
	Phase	1	1	1	1	1	1	1	1
	HP	1/3	1/3	1/3	1/3	1/3	1/3	1/3	1/3
	Amps (FLA, each)	1.5	1.5	1.5	0.8	0.8	0.8	1.5	1.5
	Amps (LRA, each)	3	3	3	1.6	1.6	1.6	3	3
Evaporator Fan	No.	1	1	1	1	1	1	1	1
	Volts	208/230	208/230	208/230	460	460	460	208/230	208/230
	Phase	1	1	1	1	1	1	1	1
	HP	1/2	1/2	1/2	1/2	1/2	1/2	1/2	1/2
	Amps (FLA, each)	2.5	2.5	2.5	1.2	1.2	1.2	2.5	2.5
	Amps (LRA, each)	4.6	4.6	4.6	2.4	2.4	2.4	4.6	4.6

1. Horsepower Per Compressor.
2. Amp Draw Per Motor. Multiply Value By Number of Motors to Determine Total Amps.

ELECTRICAL DATA – RGEA14 SERIES								
		036AJD081AA	036AJD08XAA	036AJD101AA	036AJD10XAA	042ACT081AA	042ACT101AA	042AJT081AA
Unit Information	Unit Operating Voltage Range	187-253	187-253	187-253	187-253	187-253	187-253	187-253
	Volts	208/230	208/230	208/230	208/230	208/230	208/230	208/230
	Phase	1	1	1	1	3	3	1
	Hz	60	60	60	60	60	60	60
	Minimum Circuit Ampacity	22	22	22	22	24	24	30
	Minimum Overcurrent Protection Device Size	25	25	25	25	25	25	30
	Maximum Overcurrent Protection Device Size	35	35	35	35	35	35	45
Compressor Motor	No.	1	1	1	1	1	1	1
	Volts	208/230	208/230	208/230	208/230	208/230	208/230	208/230
	Phase	1	1	1	1	3	3	1
	RPM	3450	3450	3450	3450	3450	3450	3450
	HP, Compressor 1	3 1/3	3 1/3	3 1/3	3 1/3	3 1/2	3 1/2	3 1/2
	Amps (RLA), Comp. 1	14.1	14.1	14.1	14.1	13.2	13.2	17.9
	Amps (LRA), Comp. 1	77	77	77	77	88	88	112
Condenser Motor	No.	1	1	1	1	1	1	1
	Volts	208/230	208/230	208/230	208/230	208/230	208/230	208/230
	Phase	1	1	1	1	1	1	1
	HP	1/3	1/3	1/3	1/3	1/3	1/3	1/3
	Amps (FLA, each)	1.5	1.5	1.5	1.5	1.5	1.5	1.5
	Amps (LRA, each)	3	3	3	3	3	3	3
Evaporator Fan	No.	1	1	1	1	1	1	1
	Volts	208/230	208/230	208/230	208/230	208/230	208/230	208/230
	Phase	1	1	1	1	1	1	1
	HP	1/2	1/2	1/2	1/2	3/4	3/4	3/4
	Amps (FLA, each)	2.5	2.5	2.5	2.5	6	6	6
	Amps (LRA, each)	4.6	4.6	4.6	4.6			

1. Horsepower Per Compressor.  
2. Amp Draw Per Motor. Multiply Value By Number of Motors to Determine Total Amps.

<b>ELECTRICAL DATA – RGEA14 SERIES</b>								
		<b>042AJT08XAA</b>	<b>042AJT101AA</b>	<b>042AJT10XAA</b>	<b>048ACT081AA</b>	<b>048ACT101AA</b>	<b>048ADT101AA</b>	<b>048AJT081AA</b>
<b>Unit Information</b>	Unit Operating Voltage Range	187-253	187-253	187-253	187-253	187-253	187-253	187-253
	Volts	208/230	208/230	208/230	208/230	208/230	460	208/230
	Phase	1	1	1	3	3	3	1
	Hz	60	60	60	60	60	60	60
	Minimum Circuit Ampacity	30	30	30	25	25	12	33
	Minimum Overcurrent Protection Device Size	30	30	30	25	25	35	35
	Maximum Overcurrent Protection Device Size	45	45	45	35	35	15	50
<b>Compressor Motor</b>	No.	1	1	1	1	1	1	1
	Volts	208/230	208/230	208/230	208/230	208/230	460	208/230
	Phase	1	1	1	3	3	3	1
	RPM	3450	3450	3450	3450	3450	3450	3450
	HP, Compressor 1	3 1/2	3 1/2	3 1/2	4	4	4	4
	Amps (RLA), Comp. 1	17.9	17.9	17.9	13.1	13.1	6.1	19.9
	Amps (LRA), Comp. 1	112	112	112	83.1	83.1	41	109
<b>Condenser Motor</b>	No.	1	1	1	1	1	1	1
	Volts	208/230	208/230	208/230	208/230	208/230	460	208/230
	Phase	1	1	1	1	1	1	1
	HP	1/3	1/3	1/3	1/3	1/3	1/3	1/3
	Amps (FLA, each)	1.5	1.5	1.5	2	2	1	2
	Amps (LRA, each)	3	3	3	3.9	3.9	2.2	3.9
<b>Evaporator Fan</b>	No.	1	1	1	1	1	1	1
	Volts	208/230	208/230	208/230	208/230	208/230	460	208/230
	Phase	1	1	1	1	1	1	1
	HP	3/4	3/4	3/4	3/4	3/4	3/4	3/4
	Amps (FLA, each)	6	6	6	6	6	3.2	6
	Amps (LRA, each)							

1. Horsepower Per Compressor.

2. Amp Draw Per Motor. Multiply Value By Number of Motors to Determine Total Amps.



Air

Electrical Data  
RGEA14 Series**ELECTRICAL DATA – RGEA14 SERIES**

		<b>048AJT08XAA</b>	<b>048AJT101AA</b>	<b>048AJT10XAA</b>	<b>060ACT101AA</b>	<b>060ADT101AA</b>	<b>060AJT101AA</b>	<b>060AJT10XAA</b>
<b>Unit Information</b>	Unit Operating Voltage Range	187-253	187-253	187-253	197-253	414-506	197-253	197-253
	Volts	208/230	208/230	208/230	208/230	460	208/230	208/230
	Phase	1	1	1	3	3	1	1
	Hz	60	60	60	60	60	60	60
	Minimum Circuit Ampacity	33	33	33	32	16	41	41
	Minimum Overcurrent Protection Device Size	35	35	35	35	20	45	45
	Maximum Overcurrent Protection Device Size	50	50	50	45	20	60	60
<b>Compressor Motor</b>	No.	1	1	1	1	1	1	1
	Volts	208/230	208/230	208/230	208/230	460	208/230	208/230
	Phase	1	1	1	3	3	1	1
	RPM	3450	3450	3450	3500	3500	3500	3500
	HP, Compressor 1	4	4	4	5	5	5	5
	Amps (RLA), Comp. 1	19.9	19.9	19.9	17.8	8.6	24.4	24.4
	Amps (LRA), Comp. 1	109	109	109	110	52	144.2	144.2
<b>Condenser Motor</b>	No.	1	1	1	1	1	1	1
	Volts	208/230	208/230	208/230	208/230	460	208/230	208/230
	Phase	1	1	1	1	1	1	1
	HP	1/3	1/3	1/3	1/3	1/3	1/3	1/3
	Amps (FLA, each)	2	2	2	2	1	2	2
	Amps (LRA, each)	3.9	3.9	3.9	3.9	2.2	3.9	3.9
<b>Evaporator Fan</b>	No.	1	1	1	1	1	1	1
	Volts	208/230	208/230	208/230	208/230	460/460	208/230	208/230
	Phase	1	1	1	1	1	1	1
	HP	3/4	3/4	3/4	1	1	1	1
	Amps (FLA, each)	6	6	6	7.6	4	7.6	7.6
	Amps (LRA, each)							

1. Horsepower Per Compressor.

2. Amp Draw Per Motor. Multiply Value By Number of Motors to Determine Total Amps.





## ELECTRICAL DATA – RGEA15 SERIES

		024AJT***AA	024AJV***AA	030AJT***AA	030AJV***AA	036ACT***AA	036ADT***AA	036AJT***AA	036AJV060AA	036AJV080AA 036AJV100AA
<b>Unit Information</b>	Unit Operating Voltage Range	187-253	187-253	187-253	187-253	187-253	414-506	187-253	187-253	187-253
	Volts	208/230	208/230	208/230	208/230	208/230	460	208/230	208/230	208/230
	Phase	1	1	1	1	3	3	1	1	1
	Hz	60	60	60	60	60	60	60	60	60
	Minimum Circuit Ampacity	19	19	21	21	17	10	24	23	24
	Minimum Overcurrent Protection Device Size	20	25	25	25	20	15	25	30	30
	Maximum Overcurrent Protection Device Size	25	30	30	30	25	15	35	35	35
<b>Compressor Motor</b>	No.	1	1	1	1	1	1	1	1	1
	Volts	208/230	208/230	208/230	208/230	208/230	460	208/230	208/230	208/230
	Phase	1	1	1	1	3	3	1	1	1
	RPM	3450	3450	3450	3450	3450	3450	3450	3450	3450
	HP, Compressor 1	2 1/6	2 1/6	2 2/3	2 2/3	3 1/3	3 1/3	3 1/3	3 1/3	3 1/3
	Amps (RLA), Comp. 1	11.2	11.2	12.8	12.8	9	5.6	14.1	14.1	14.1
	Amps (LRA), Comp. 1	60.8	60.8	64	64	71	38	77	77	77
<b>Condenser Motor</b>	No.	1	1	1	1	1	1	1	1	1
	Volts	208/230	208/230	208/230	208/230	208/230	460	208/230	208/230	208/230
	Phase	1	1	1	1	1	1	1	1	1
	HP	1/3	1/3	1/3	1/3	1/3	1/3	1/3	1/3	1/3
	Amps (FLA, each)	1.5	1.5	1.5	1.5	1.5	0.8	1.5	1.5	1.5
	Amps (LRA, each)	3	3	3	3	3	1.6	3	3	3
<b>Evaporator Fan</b>	No.	1	1	1	1	1	1	1	1	1
	Volts	208/230	208/230	208/230	208/230	208/230	460/460	208/230	208/230	208/230
	Phase	1	1	1	1	1	1	1	1	1
	HP	1/3	1/2	1/2	1/2	1/2	1/2	1/2	1/2	1/2
	Amps (FLA, each)	2.8	3.5	2.8	3.5	4.1	2.1	4.1	3.5	4.0
	Amps (LRA, each)									

1. Horsepower Per Compressor.

2. Amp Draw Per Motor. Multiply Value By Number of Motors to Determine Total Amps.



### ELECTRICAL DATA – RGEA15 SERIES

		042ACT***AA	042AJT***AA	042AJV***AA	048ACT***AA	048ADT***AA	048AJT***AA	048AJV***AA	060ACT***AA	060ADT***AA
<b>Unit Information</b>	Unit Operating Voltage Range	187-253	187-253	187-253	187-253	414-506	187-253	187-253	197-253	414-506
	Volts	208/230	208/230	208/230	208/230	460	208/230	208/230	208/230	460
	Phase	3	1	1	3	3	1	1	3	3
	Hz	60	60	60	60	60	60	60	60	60
	Minimum Circuit Ampacity	24	30	28	25	12	33	34	30	15
	Minimum Overcurrent Protection Device Size	25	30	35	25	35	35	40	50	20
	Maximum Overcurrent Protection Device Size	35	45	45	35	15	50	50	45	20
<b>Compressor Motor</b>	No.	1	1	1	1	1	1	1	1	1
	Volts	208/230	208/230	208/230	208/230	460	208/230	208/230	208/230	460
	Phase	3	1	1	3	1	1	1	3	3
	RPM	3450	3450	3450	3450	3450	3450	3450	3450	3450
	HP, Compressor 1	3 1/2	3 1/2	3 1/2	4	4	4	4	5	5
	Amps (RLA), Comp. 1	13.2	17.9	17.9	13.1	6.1	19.9	19.9	16.2	7.6
	Amps (LRA), Comp. 1	88	112	112	83.1	43	109	109	110	52
<b>Condenser Motor</b>	No.	1	1	1	1	1	1	1	1	1
	Volts	208/230	208/230	208/230	208/230	460	208/230	208/230	208/230	460
	Phase	1	1	1	1	1	1	1	1	1
	HP	1/3	1/3	1/3	1/3	1/3	1/3	1/3	1/3	1/3
	Amps (FLA, each)	1.5	1.5	1.5	2	1	2	2	2	1
	Amps (LRA, each)	3	3	3	3.9	3.9	3.9	3.9	3.9	2.2
<b>Evaporator Fan</b>	No.	1	1	1	1	1	1	1	1	1
	Volts	208/230	208/230	208/230	208/230	460	208/230	208/230	208/230	460/460
	Phase	1	1	1	1	1	1	1	1	1
	HP	3/4	3/4	3/4	3/4	3/4	3/4	1	1	1
	Amps (FLA, each)	6	6	4	6	3.2	6	6.8	7.6	4
	Amps (LRA, each)									

1. Horsepower Per Compressor.
2. Amp Draw Per Motor. Multiply Value By Number of Motors to Determine Total Amps.



ELECTRICAL DATA – RGEA15 SERIES									
		060AJT***AA	060AJV***AA						
Unit Information	Unit Operating Voltage Range	197-253	197-253						
	Volts	208/230	208/230						
	Phase	1	1						
	Hz	60	60						
	Minimum Circuit Ampacity	46	45						
	Minimum Overcurrent Protection Device Size	50	60						
	Maximum Overcurrent Protection Device Size	70	70						
Compressor Motor	No.	1	1						
	Volts	208/230	208/230						
	Phase	1	1						
	RPM	3450	3450						
	HP, Compressor 1	5	5						
	Amps (RLA), Comp. 1	28.8	28.8						
	Amps (LRA), Comp. 1	152.9	152.9						
Condenser Motor	No.	1	1						
	Volts	208/230	208/230						
	Phase	1	1						
	HP	1/3	1/3						
	Amps (FLA, each)	2	2						
	Amps (LRA, each)	3.9	3.9						
Evaporator Fan	No.	1	1						
	Volts	208/230	208/230						
	Phase	1	1						
	HP	1	1						
	Amps (FLA, each)	7.6	6.8						
	Amps (LRA, each)								

1. Horsepower Per Compressor.
2. Amp Draw Per Motor. Multiply Value By Number of Motors to Determine Total Amps.

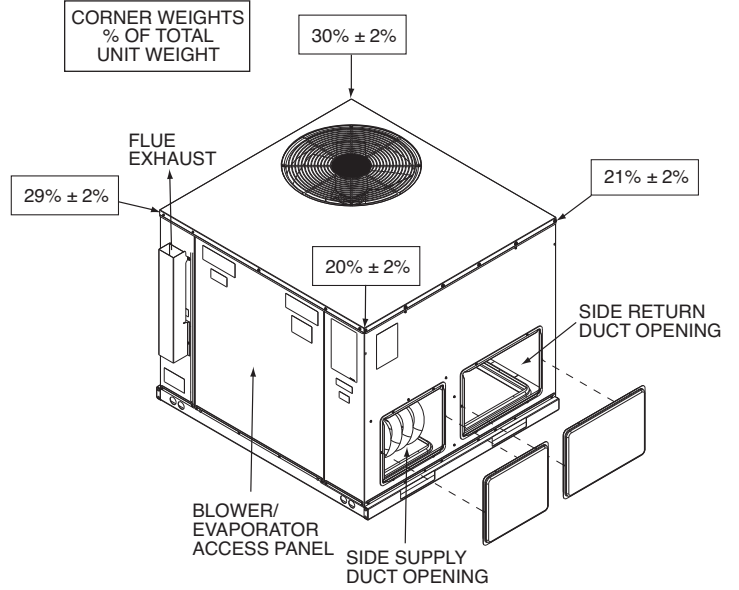
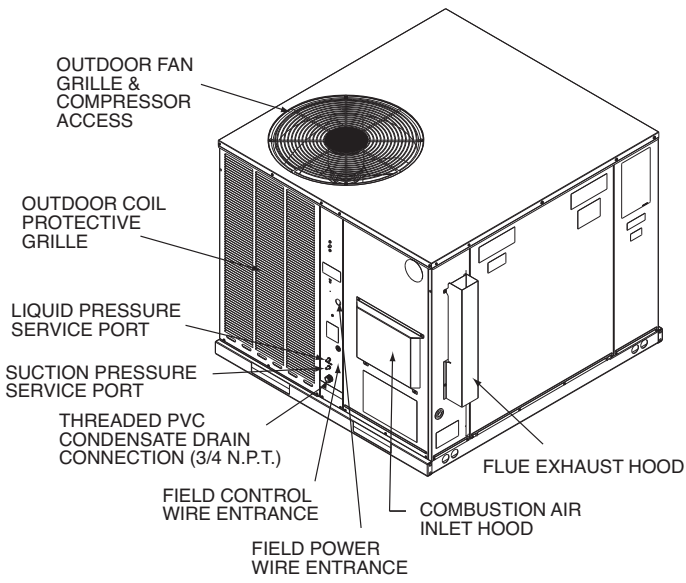

### TOP VIEW

### BOTTOM VIEW

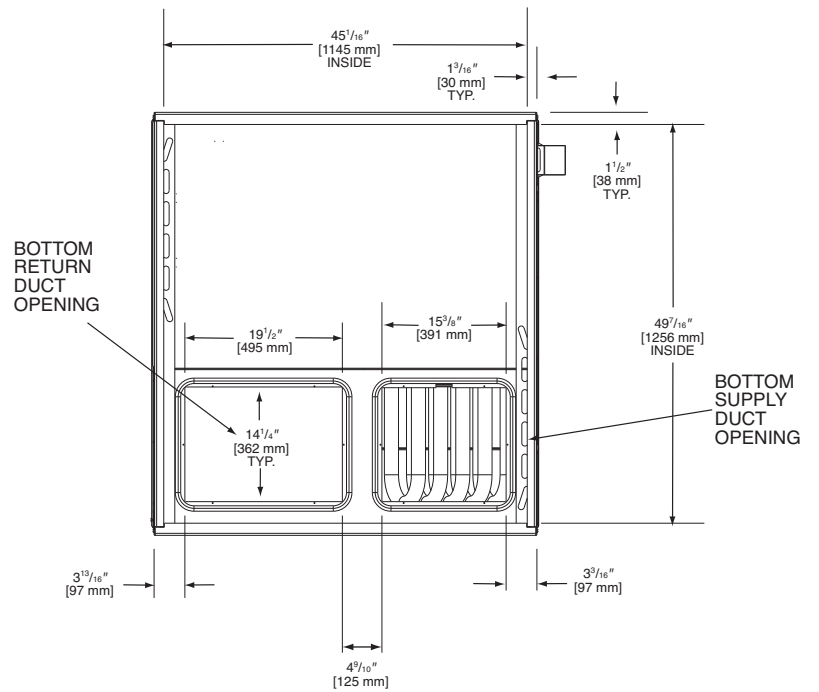
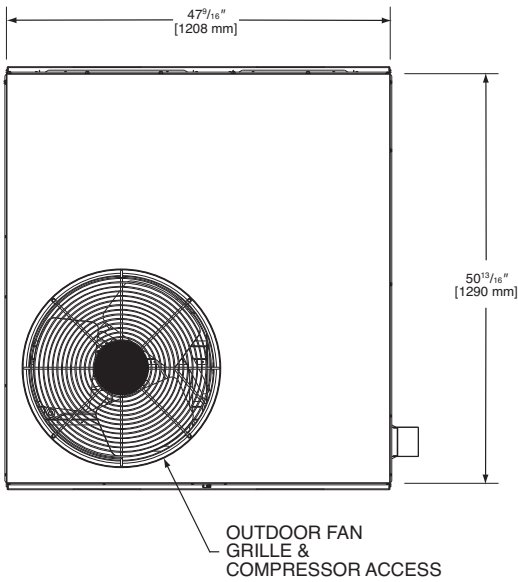

[ ] Designates Metric Conversions

### SIDE VIEW

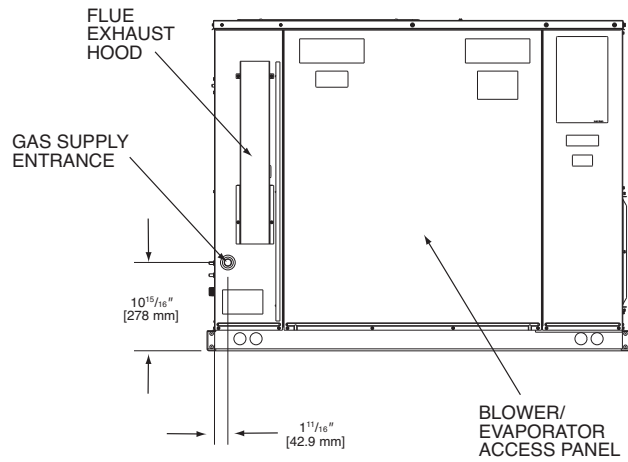

### SIDE VIEW

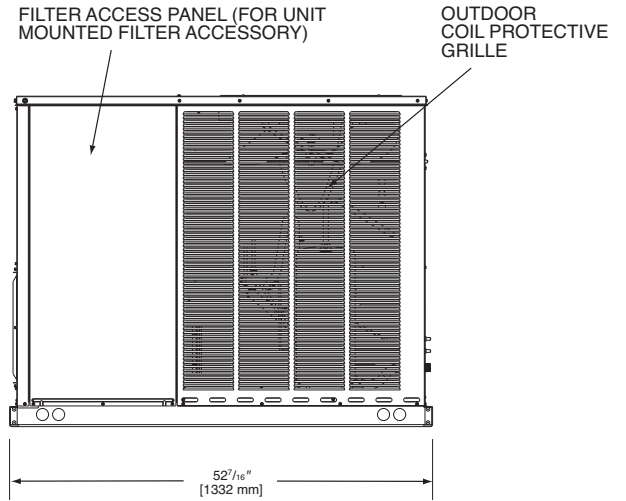

### FRONT VIEW

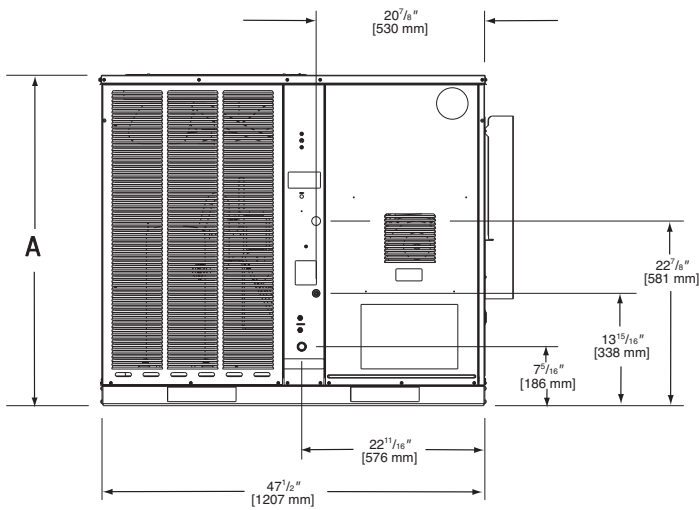

### BACK VIEW

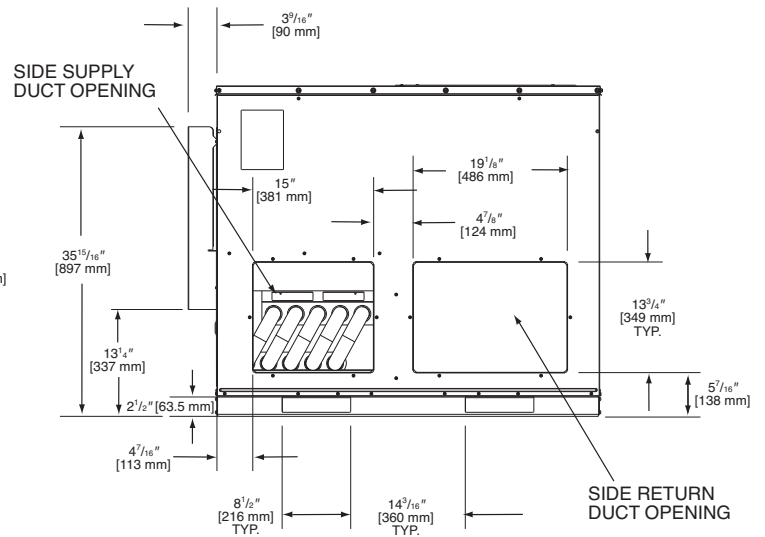

SHOWN WITH DUCT COVERS REMOVED.

Models RGEA 14/15	Height "A"
024, 030, 036, 042	35 <sup>15</sup> / <sub>16</sub> "
048, 060	41"

[ ] Designates Metric Conversions

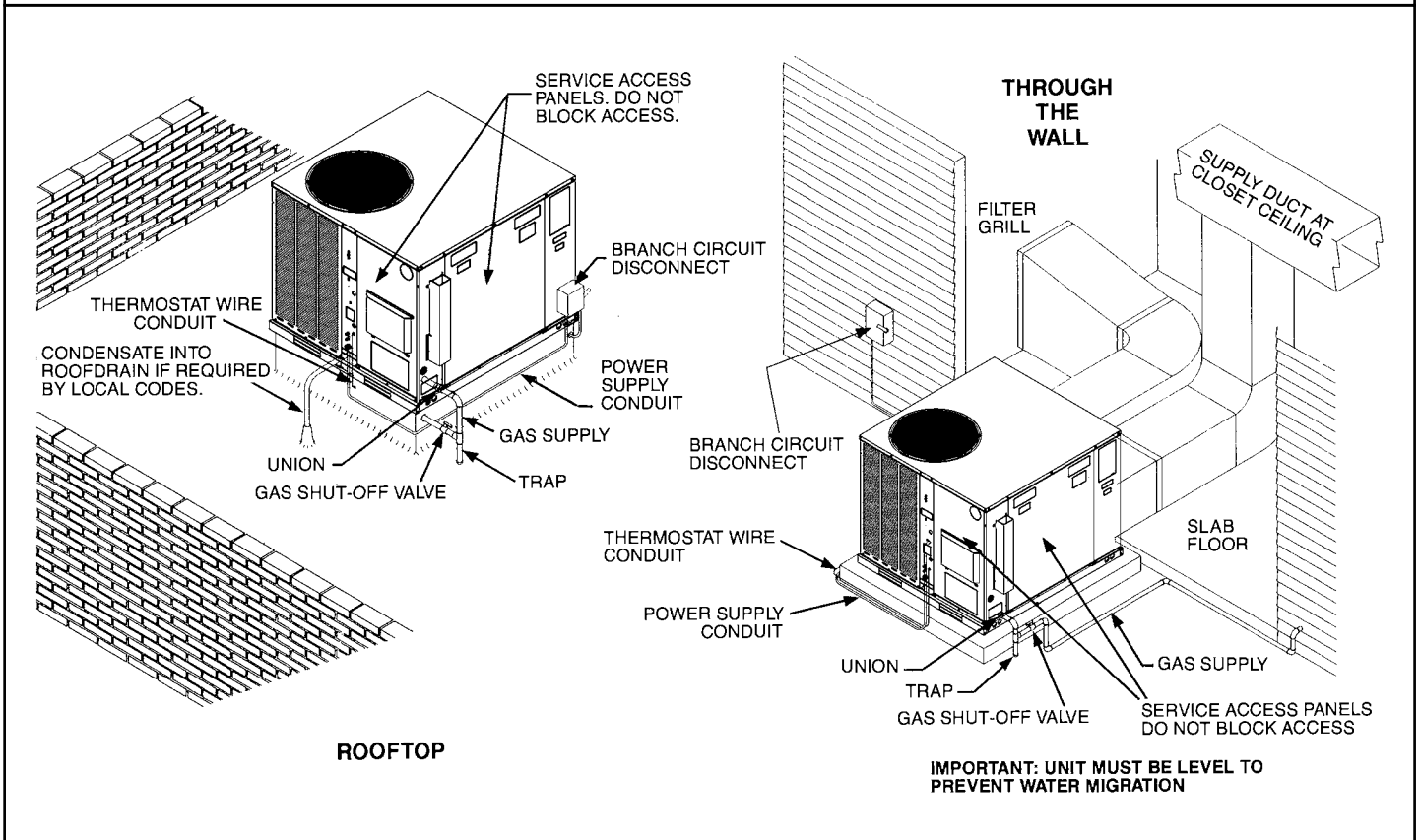
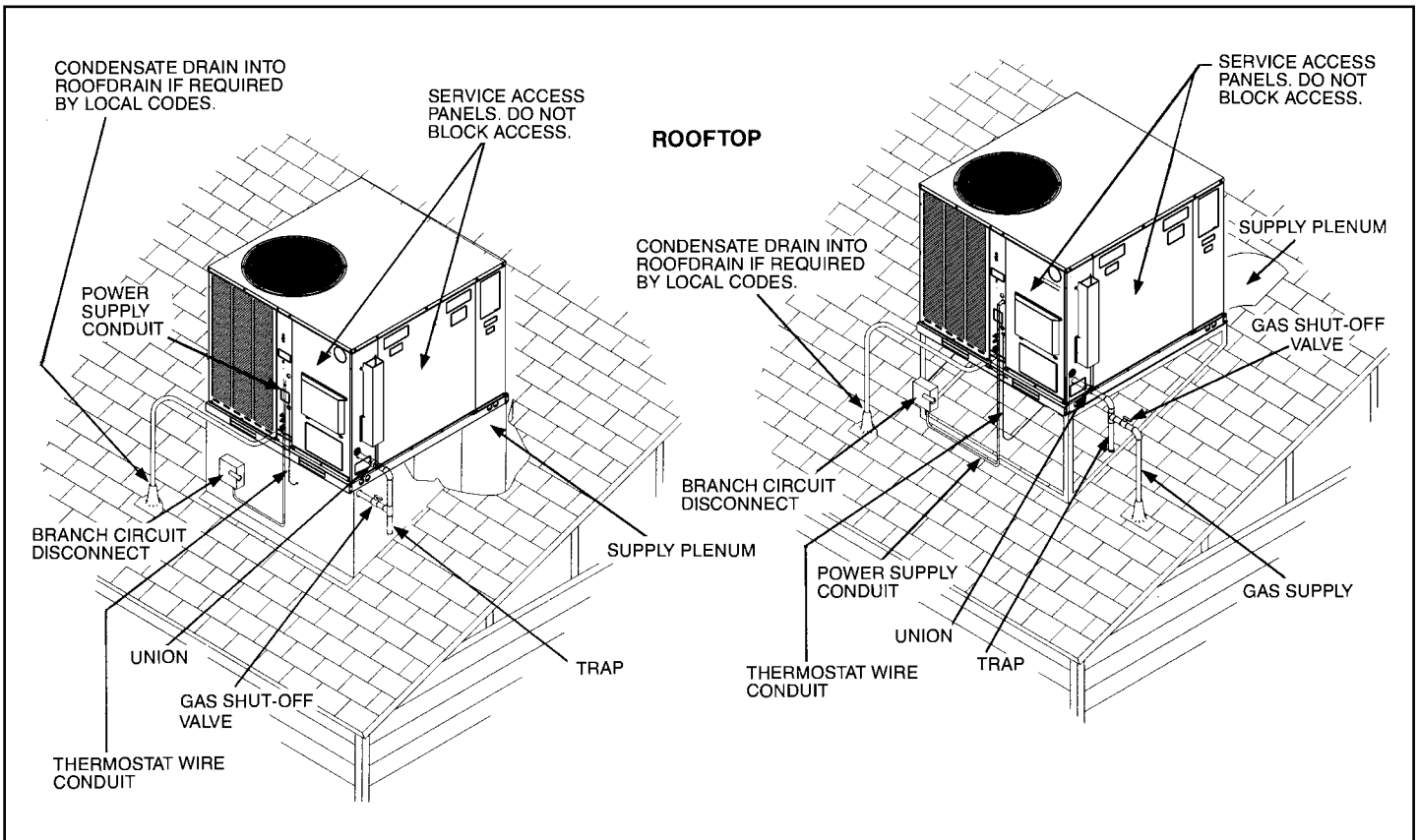

[ ] Designates Metric Conversions

## ACCESSORY EQUIPMENT

Accessory Description	Model Application	Accessory Model No.
Thermostats	RGEA14/15	See Thermostat Specification Sheet (T11-001)
Roofcurbs	RGEA14/15	RXSG-AAA08 (8" [203 mm] Height) RXSG-AAA14 (14" [356 mm] Height) RXSG-AAA24 (24" [610 mm] Height)
Supply & Return Diffusers	RGEA14/15	RXRN-BD15
Economizers (Sideflow Only)	RGEA14/15	AXRE-CCA30 (3 Position) AXRD-CCM10 (Fully Modulating)
Economizers (Downflow Only)	RGEA14/15	AXRE-CAA30 (3 Position) AXRD-CAM10 (Fully Modulating)
Fresh Air Damper	RGEA14/15	AXRF-FAB1 (Motorized-35%) AXRF-FAA1 (Fixed-35%)
Rectangular to Round Transition (Downflow)	RGEA14/15	RXMC-CA02 (16" [406 mm] Ducts) RXMC-CA03 (18" [457 mm] Ducts)
Filter Kit	RGEA14/15	RXR-01
Sideflow Rectangular to Round Transition	RGEA14/15	RXMC-BA01
LP Conversion Kits	RGEA14/15	RXGJ-EP84W (White-Rodgers Gas Valve) RXGJ-EP85H (Honeywell Gas Valve) RXGJ-FP28
Low Ambient Control	RGEA14/15	RXRZ-B01
High Pressure Control	RGEA14/15 <sup>2</sup>	RXAB-E01
Low Pressure Control	RGEA14/15 <sup>2</sup>	RXAC-C01
Canadian High Altitude Kit (for Natural Gas only <sup>1</sup> )	RGEA14/15	RXR-01

<sup>1</sup> If a particular unit is to be converted to operate on LP (propane) for elevations above 2000 ft. [609.6 m] in Canada, the existing Natural Gas to LP Conversion Kits for the subject models already contain the necessary orifices and instructions to de-rate the input for 2000-4500 ft. [609.6-1371.6 m] Canadian applications.

<sup>2</sup> High pressure switches are standard for RGEA15 Models.

[ ] Designates Metric Conversions

## COMMON SUPPLY/RETURN CONCENTRIC AIR DIFFUSER

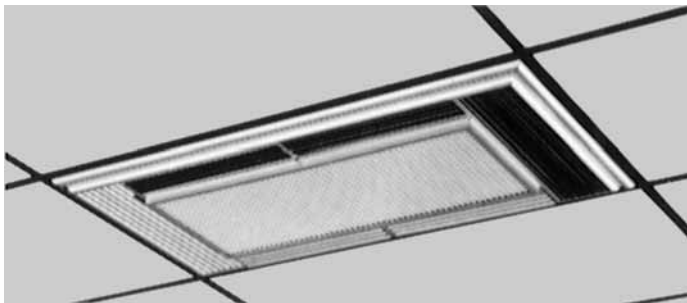

## SUPPLY/RETURN DIFFUSER

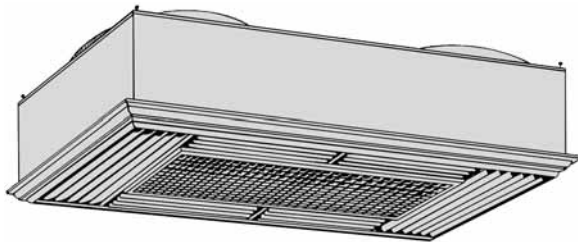

Designed to convert a side by side or an over and under arrangement into a concentric distribution of air. The diffuser is flush mounted, completely insulated, assembled, and internally baffled to provide four way supply air distribution with a center return. To make the assembly complete and ready to fit into a 2' [0.61 m] x 4' [1.22 m] suspended ceiling grid, the diffuser includes adjustable supply louvers, hanging rings, anti-sweat gasket, and round flanges for use with flexible ducts.

Model No.	Diameter Inches [mm]	Shipping Wt. Lbs. [kg]	Dimension A Inches [mm]
RXRN-BD15	16 [406]	90 [40.82]	20 1/2 [521]

DIFFUSER INSTALLS FLUSH WITH CEILING

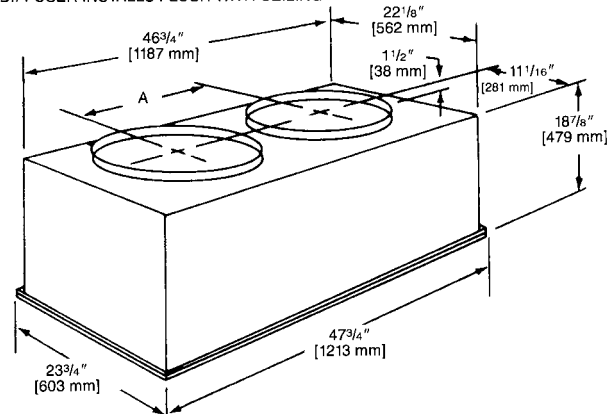

**NOTE:** The location of the combination supply and return diffuser should not exceed 10 feet [3.05 m] above the floor level for units @ 1000 CFM [472 L/s] or less and 12 [3.66 m] to 14 feet [4.27 m] above the floor level for units with CFM greater than 1000 [472 L/s]. If the diffuser is installed with a greater distance than recommended above, the supply air may become stratified above the required comfort area causing uncomfortable conditions.

## AIRFLOW/PRESSURE DROP INFORMATION (INCHES W.C. [kPa])

Accessory	Approximate CFM [L/s]-Supply Air			
	1300 [614]	1575 [743]	1800 [850]	2200 [1038]
Plenum & Supply/Return Duct	.07 [.017]	.10 [.024]	.12 [.030]	.17 [.042]
Diffuser	.09 [.022]	.13 [.032]	.16 [.040]	.24 [.060]
Economizer	.06 [.015]	.09 [.022]	.11 [.027]	.17 [.042]

## SUPPLY AIR/PERFORMANCE

Diffuser Airflow CFM [L/s]	Range of Throw Ft. [m]
800 [378]-1200 [566]	14 [4.27]-16 [4.88]
1600 [755]-2000 [944]	18 [5.49]-28 [8.53]

## THERMOSTATS



**200-Series \***  
Programmable



**300-Series \***  
Deluxe  
Programmable  
**400-Series \***  
Special Applications/  
Programmable

Brand	Descriptor (3 Characters)	Series (3 Characters)	System (2 Characters)	Type (2 Characters)
RHC	- TST	213	UN	MS
RHC=Rheem	TST=Thermostat	200=Programmable 300=Deluxe Programmable 400=Special Applications/ Programmable	GE=Gas/Electric UN=Universal (AC/HP/GE) MD=Modulating Furnace DF=Dual Fuel	SS=Single-Stage MS=Multi-Stage

\* Photos are representative. Actual models may vary.

For detailed thermostat match-up information,  
see specification sheet form number T11-001.



# DUCT ADAPTERS RECTANGULAR TO ROUND TRANSITIONS (DOWNFLOW)

**RXMC-CA02**

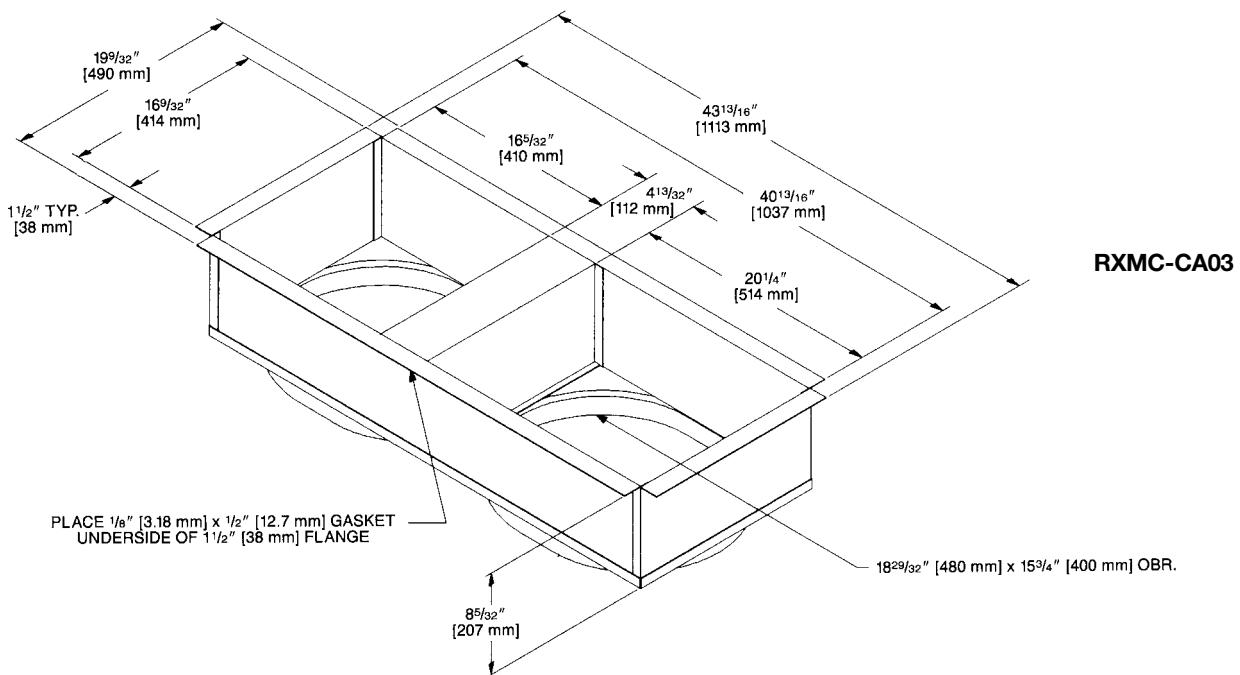
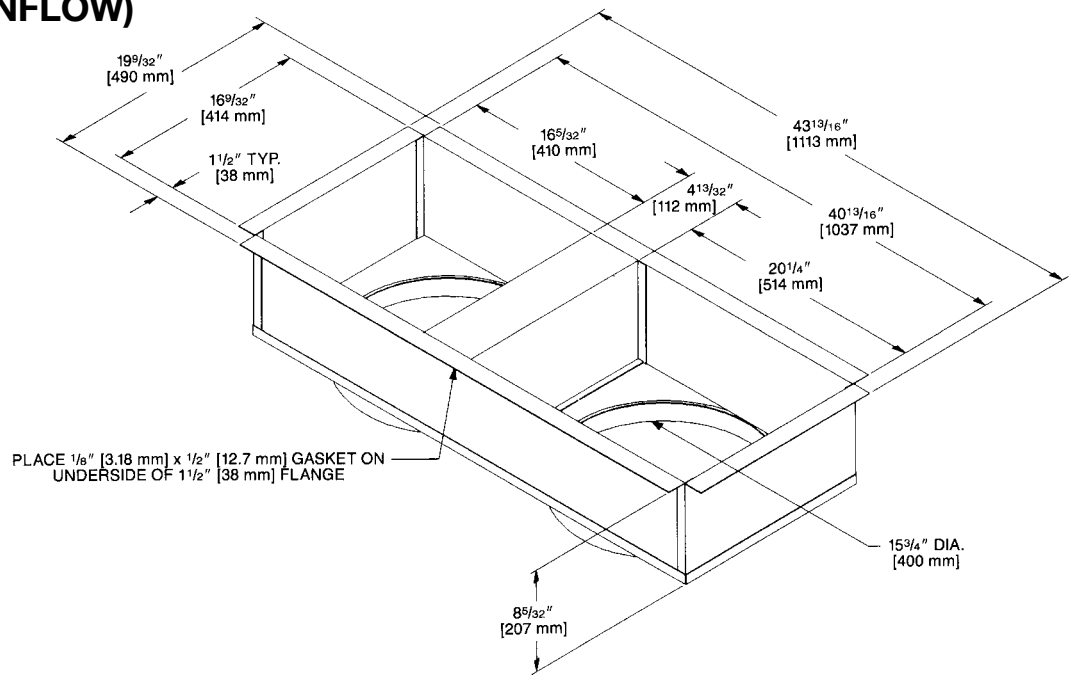

[ ] Designates Metric Conversions

## FRESH AIR DAMPER

### AXRF-FAA1 (Fixed - 0-35%)

The 0-35% manual outside Air Damper is designed to replace the unit return air duct cover. No drilling or damper assembly is required. The amount of outside air (0-35%) is controlled by simply adjusting the side damper.

### AXRF-FAB1 (Motorized - 0-35%)

The 0-35% motorized outside Air Damper is designed to replace the unit return air duct cover. No drilling or damper assembly is required. The control motor opens the adjustable slide damper when the unit blower motor is energized.

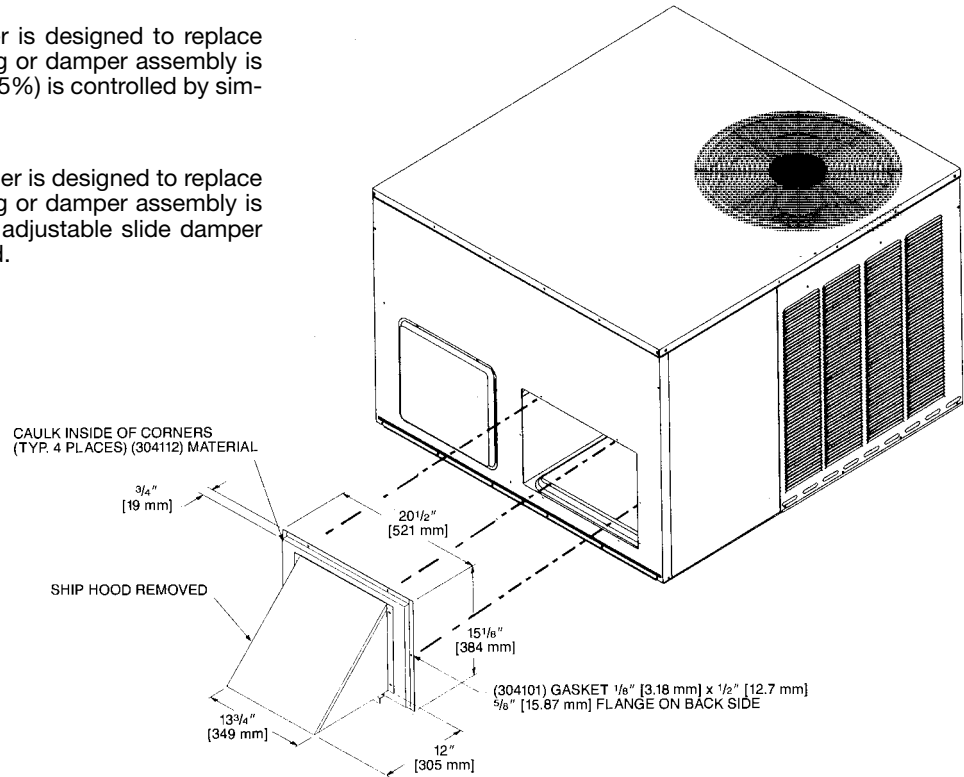

## ECONOMIZERS

### RXRE-CAA30 (3 Position) and RXRD-CAM10 (Fully Modulating)

#### AXRE-CAA30 (3 Position)

Provided with enthalpy control, and mixed air sensor. Settings include fully open, fully closed and adjustable mid point.

#### AXRD-CAM10 (Fully Modulating)

Provided with enthalpy control, mixed air sensor and minimum position potentiometer for proportioning (modulating) the amount of fresh air.

**NOTE:** See economizer installation instructions for correct filter access door.

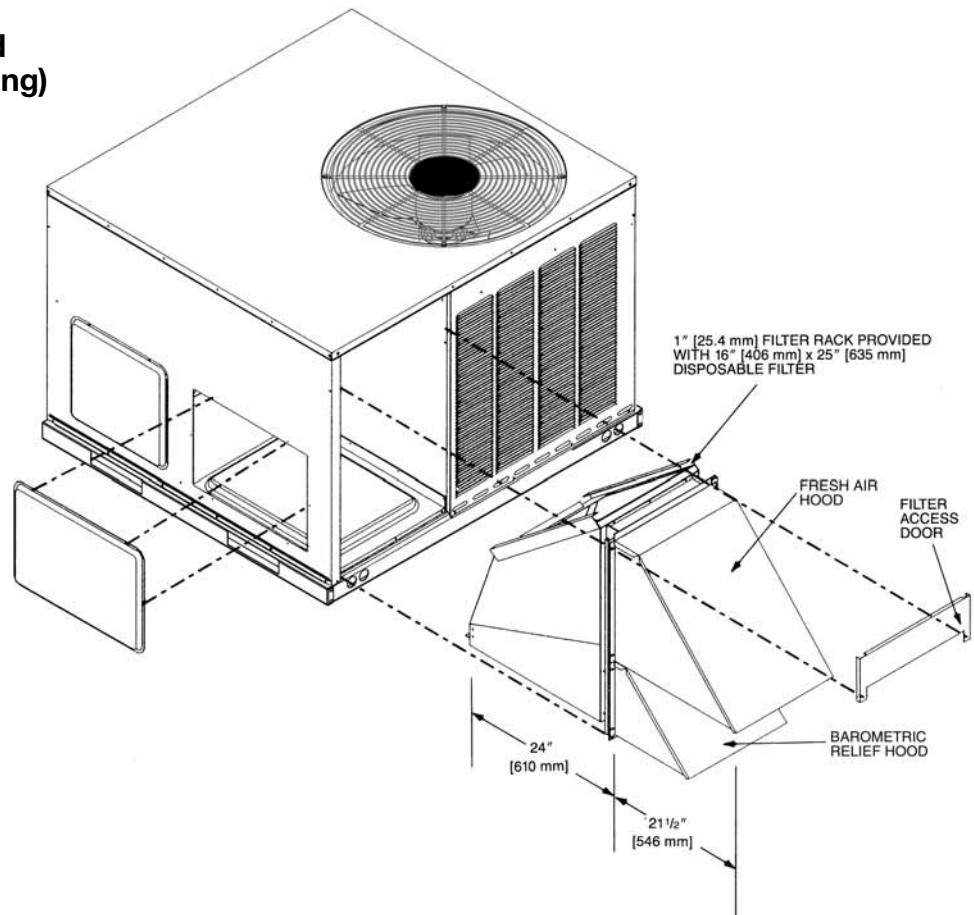

[ ] Designates Metric Conversions

## ECONOMIZERS

### RXRD-CCM10 (Fully Modulating) and RXRE-CCA30 (3 Position) Horizontal Application

#### AXRD-CCM10 (Fully Modulating)

Provided with enthalpy control, mixed air sensor and minimum position potentiometer for proportioning (modulating) the amount of fresh air.

#### AXRE-CCA30 (3-Position)

Has outdoor air sensor, minimum position potentiometer and mixed air sensor to provide three damper positions.

[ ] Designates Metric Conversions

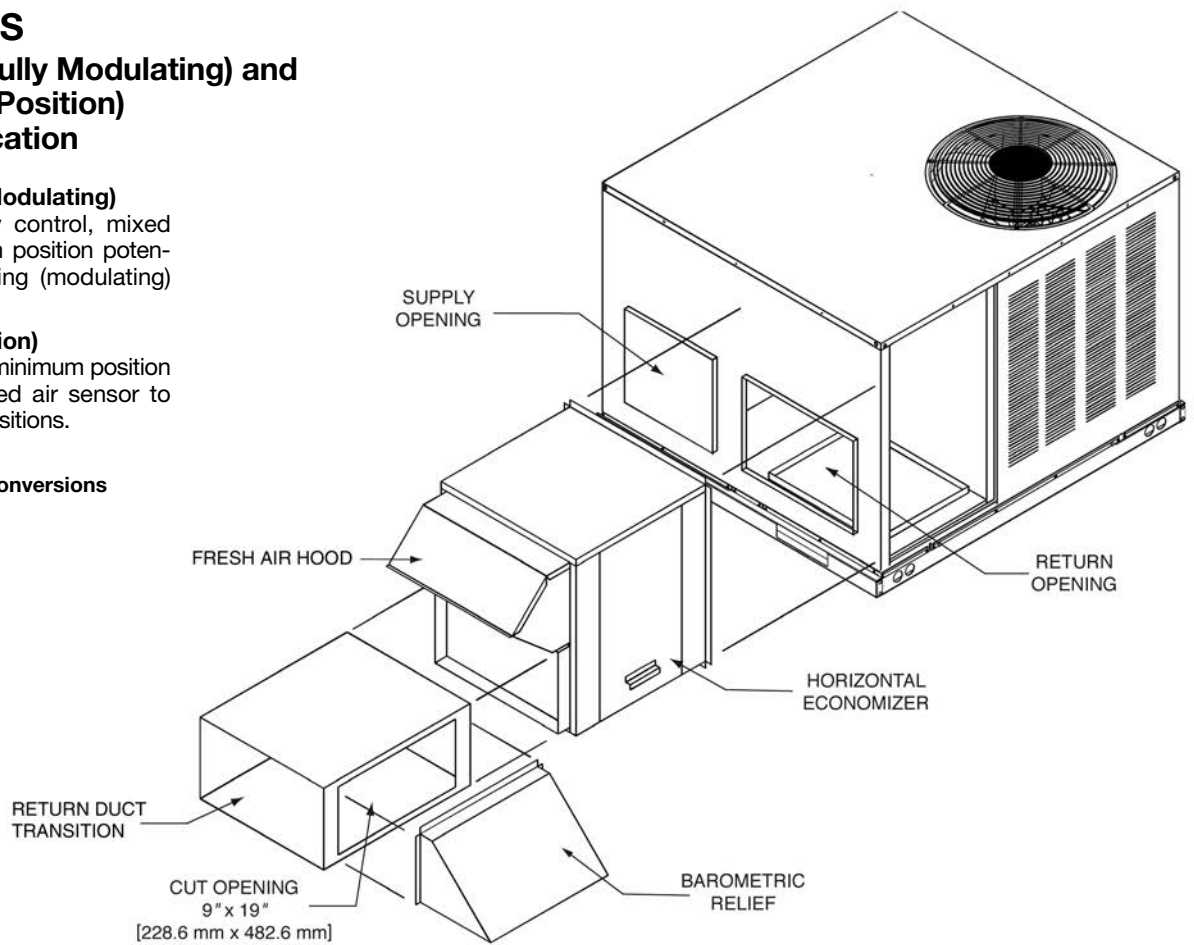

# FILTER KIT INSTALLATION

## RXRY-B01

For use in either vertical or horizontal discharge.

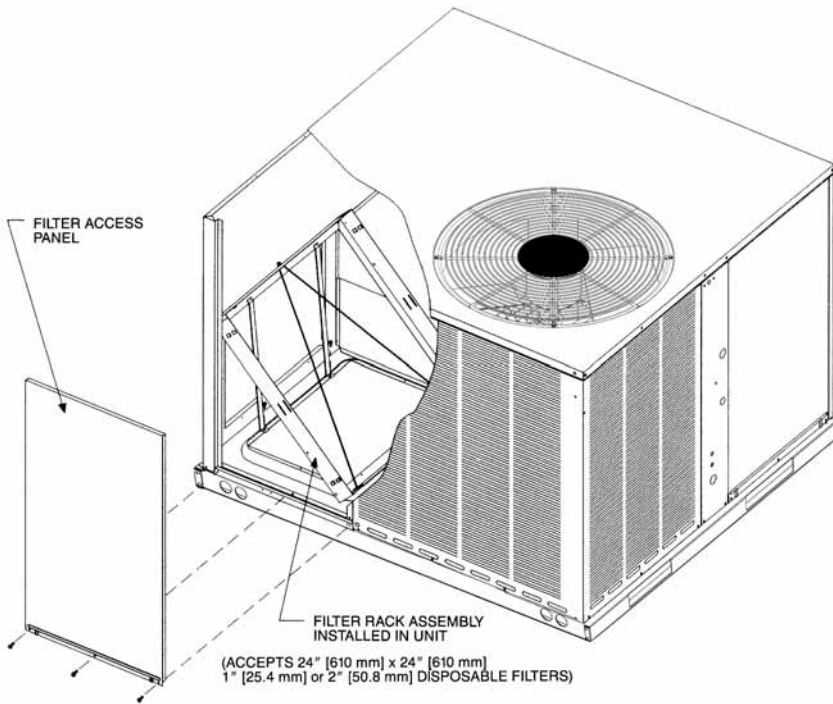

Airflow Pressure Drop, Inches W.C. [kPa]		
CFM [L/s]	1" Filter	2" Filter
500 [236]	.02 [.0050]	.03 [.0075]
600 [283]	.02 [.0050]	.03 [.0075]
700 [330]	.03 [.0075]	.04 [.0010]
800 [378]	.04 [.0010]	.05 [.0124]
900 [425]	.05 [.0124]	.06 [.0149]
1000 [472]	.07 [.0174]	.08 [.0199]
1100 [519]	.08 [.0199]	.09 [.0224]
1200 [566]	.10 [.0249]	.12 [.0299]
1300 [614]	.13 [.0324]	.15 [.0373]
1400 [661]	.16 [.0398]	.19 [.0473]
1500 [708]	.19 [.0473]	.21 [.0523]
1600 [755]	.20 [.0498]	.23 [.0572]
1700 [802]	.21 [.0523]	.24 [.0598]
1800 [850]	.22 [.0548]	.25 [.0623]
1900 [897]	.24 [.0598]	.27 [.0672]
2000 [944]	.26 [.0647]	.29 [.0722]

[ ] Designates Metric Conversions

## DUCT ADAPTER SIDEFLOW SQUARE TO ROUND TRANSITION RXMC-A01

Adapts the side rectangular supply and return openings to 14" [356 mm] diameter round openings. Adapters provided with same finish as unit and also provided with thermal insulation.

[ ] Designates Metric Conversions

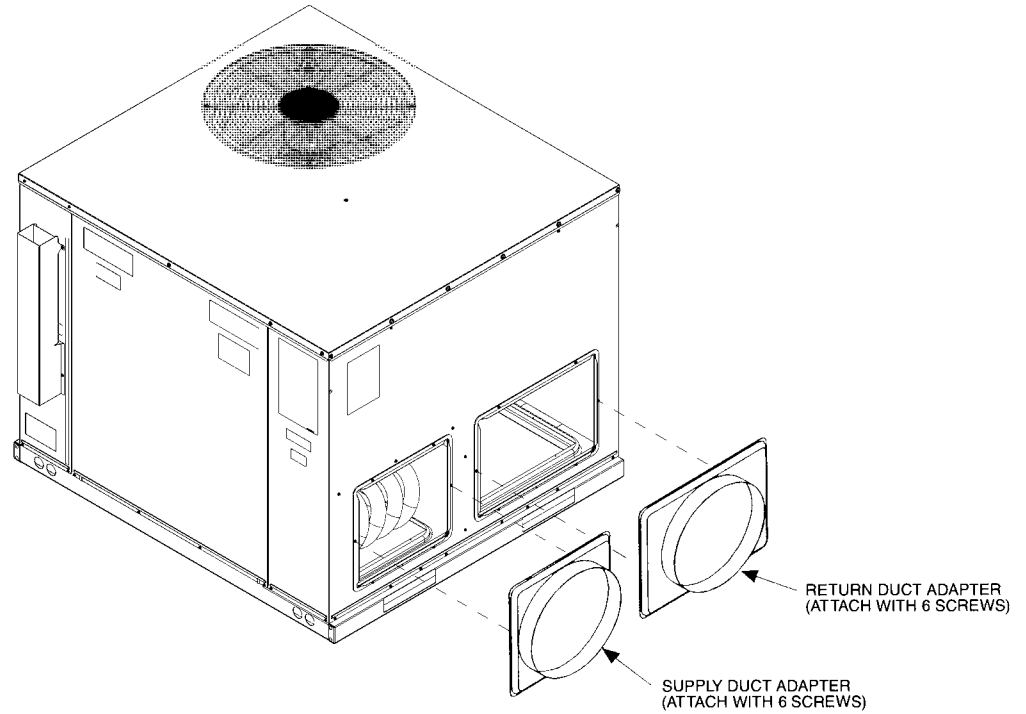

# ROOFCURB (Full Perimeter)

## RXSG-AAA08, RXSG-AAA14 and RXSG-AAA24

Hinged corners make for fast, easy set-up.

**RXSG-AAA08**  
(8" [203 mm] High)

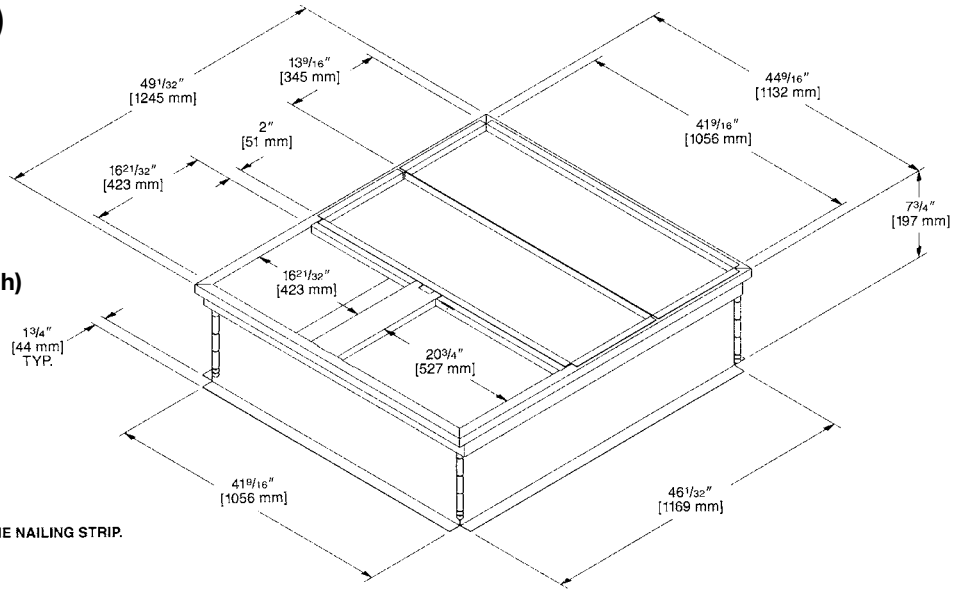

NOTE: PERIMETER OF ROOFCURB IS SUPPLIED WITH A NOMINAL 1" [25.4 mm] x 4" [102 mm] PINE NAILING STRIP.

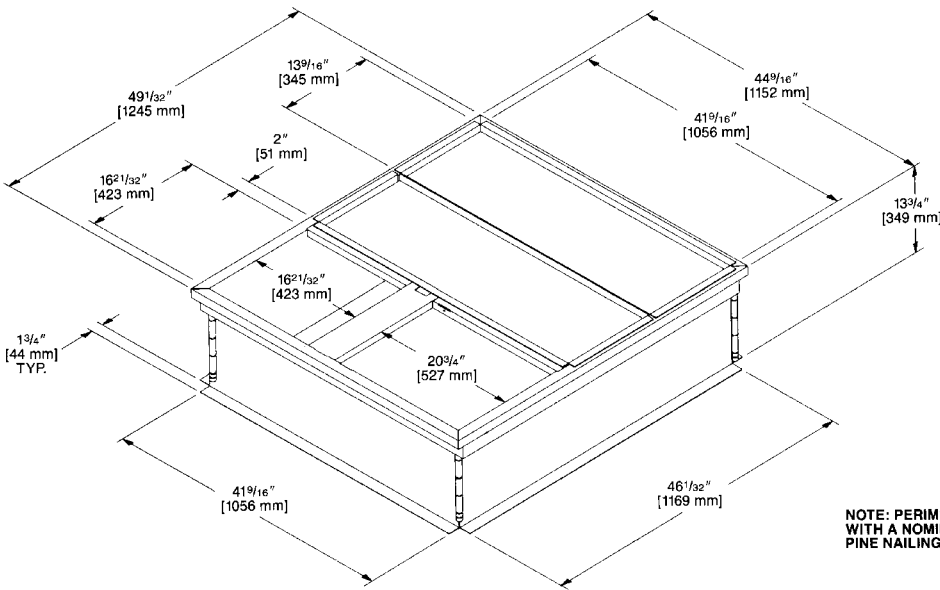

**RXSG-AAA14**  
(14" [356 mm] High)

NOTE: PERIMETER OF ROOFCURB IS SUPPLIED WITH A NOMINAL 1" [25.4 mm] x 4" [102 mm] PINE NAILING STRIP.

**RXSG-AAA24**  
(24" [610 mm] High)

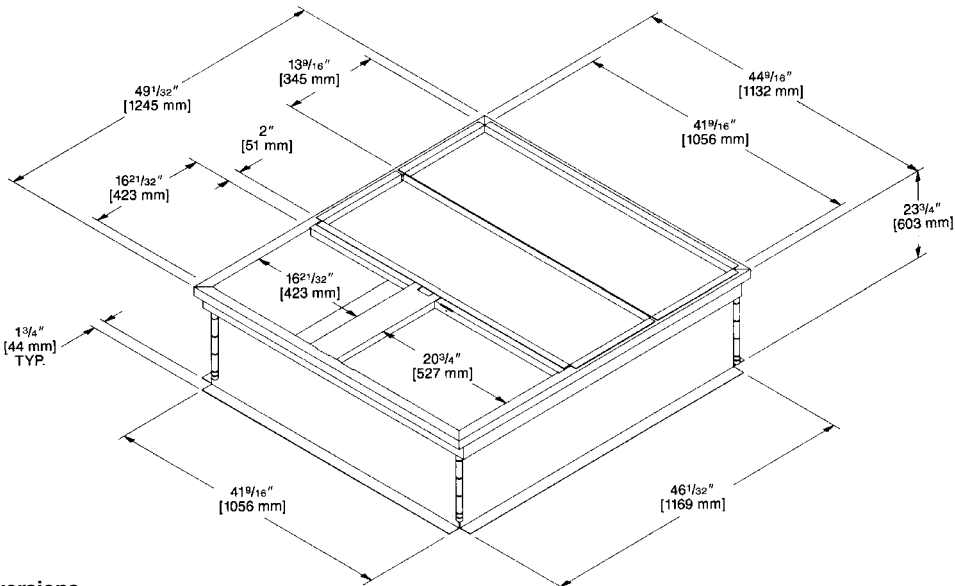

[ ] Designates Metric Conversions

# PACKAGE AIR CONDITIONERS & PACKAGE GAS/ELECTRIC UNITS ROOFCURB INSTALLATION (Full Perimeter)

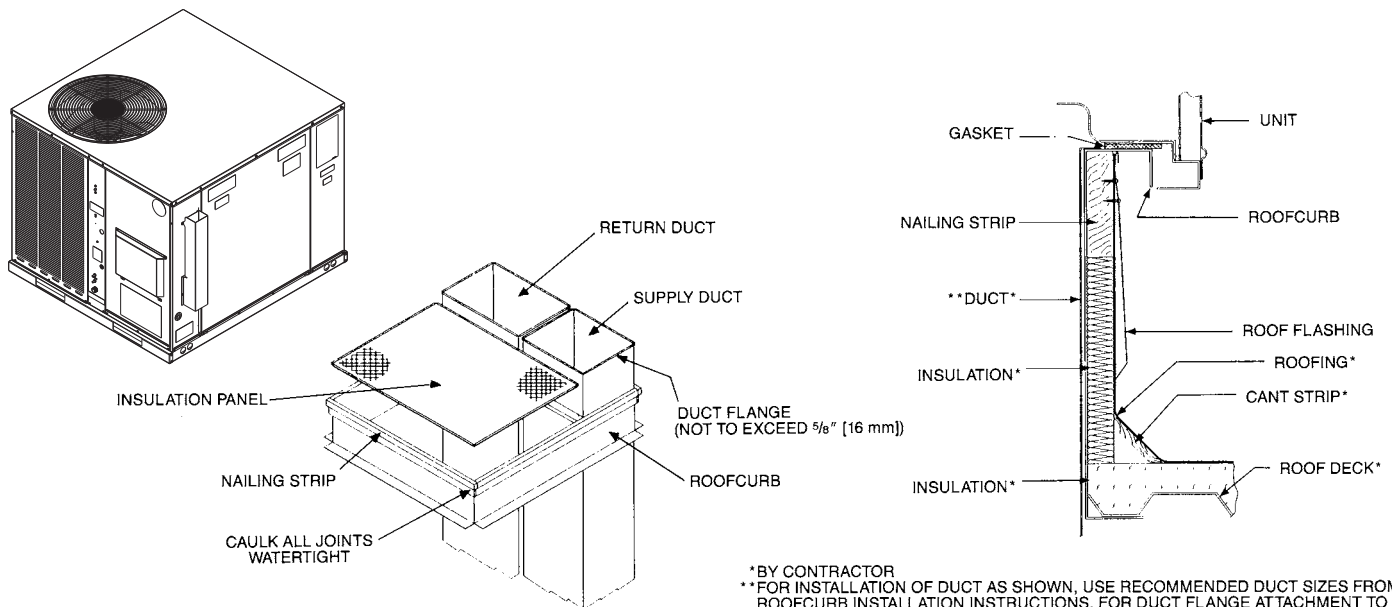

\*BY CONTRACTOR  
 \*\*FOR INSTALLATION OF DUCT AS SHOWN, USE RECOMMENDED DUCT SIZES FROM ROOFCURB INSTALLATION INSTRUCTIONS. FOR DUCT FLANGE AT ATTACHMENT TO UNIT, SEE UNIT INSTALLATION INSTRUCTIONS FOR RECOMMENDED DUCT SIZES.

## ROOFCURB ADAPTERS

Fabricated from galvanized steel to adapt the New cabinet to the old style curb. All are furnished with a New gasket.

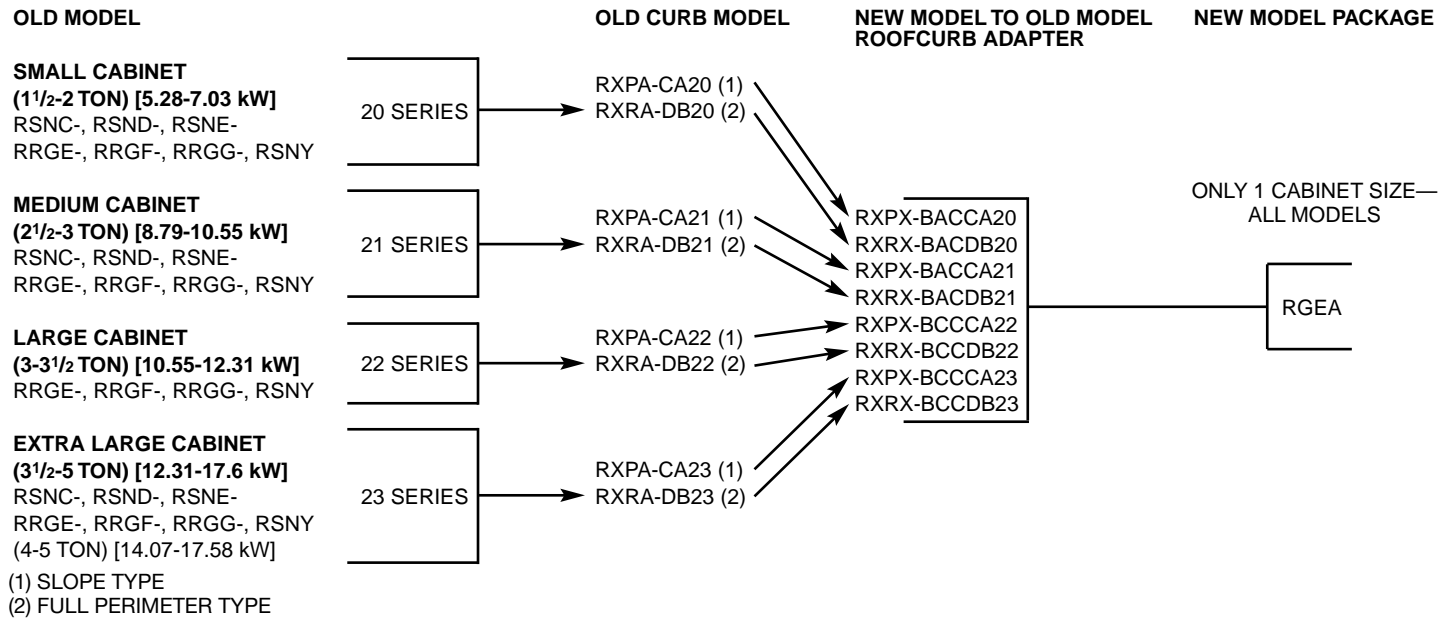

(1) SLOPE TYPE  
 (2) FULL PERIMETER TYPE

[ ] Designates Metric Conversions



**PRINTING INSTRUCTIONS:** MAKE EXACTLY 8.0 IN X 10.0 IN. WHITE BACKGROUND WITH BLACK PRINTING  
**MATERIAL:** PRESSURE SENSITIVE, ADHESIVE BACKED LABEL

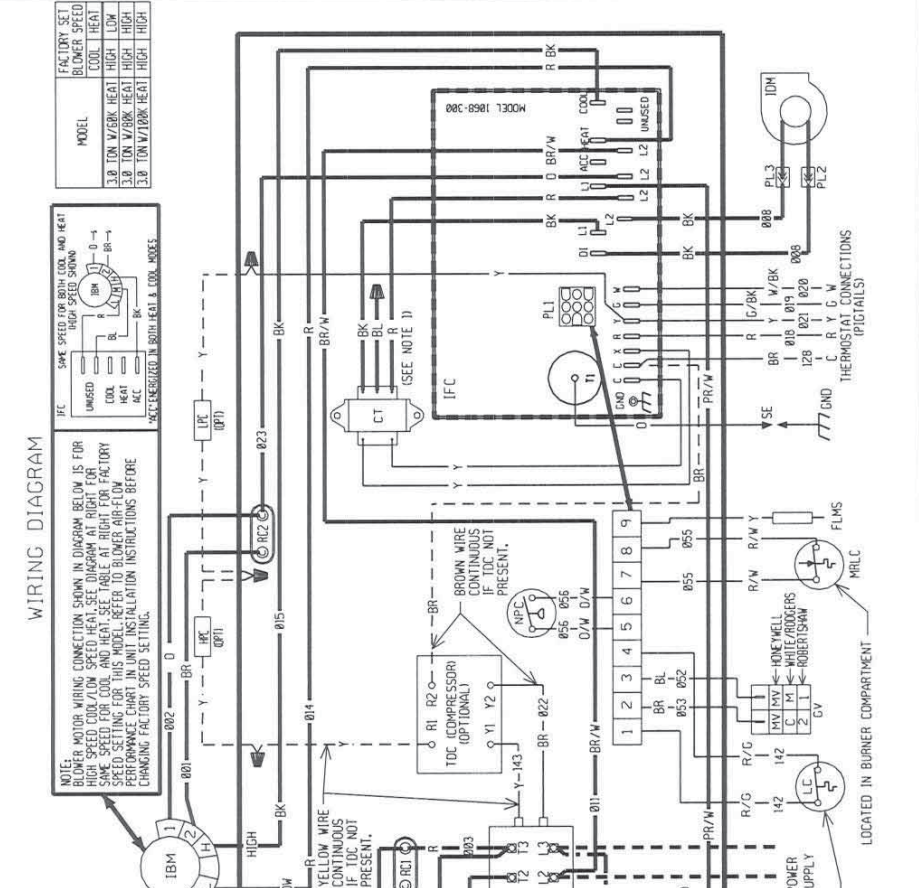
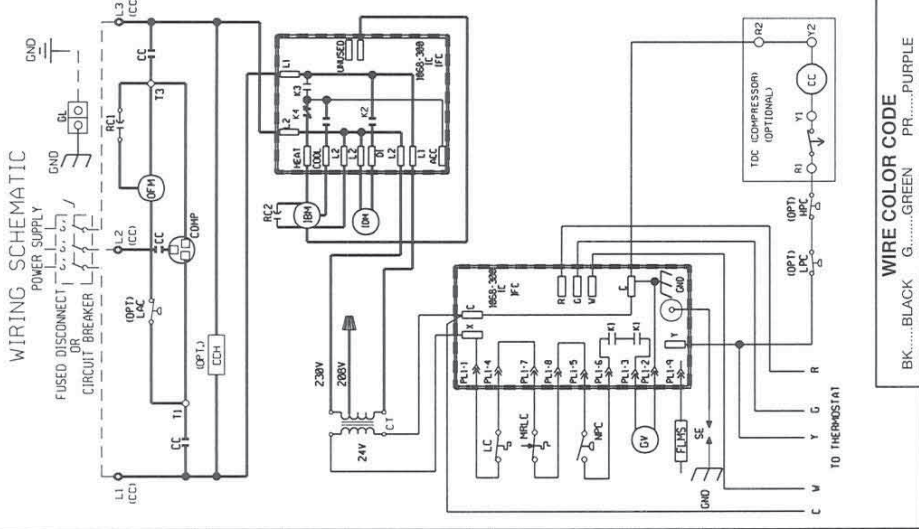

<p><b>PRINTING INSTRUCTIONS:</b> MAKE EXACTLY 8.0 IN X 10.0 IN. WHITE BACKGROUND WITH BLACK PRINTING <b>MATERIAL:</b> PRESSURE SENSITIVE, ADHESIVE BACKED LABEL</p>	<p><b>WIRING SCHEMATIC</b></p> <p>POWER SUPPLY FUSED DISCONNECT CIRCUIT BREAKER</p> <p>COMP CCH (OPT)</p> <p>24V 208V</p> <p>24V 208V</p> <p>TO THERMOSTAT</p> <p>WIRE COLOR CODE</p> <table border="1"> <tr> <td>BK.....BLACK</td> <td>G.....GREEN</td> <td>PR.....PURPLE</td> </tr> <tr> <td>BR.....BROWN</td> <td>GY.....GRAY</td> <td>R.....RED</td> </tr> <tr> <td>BL.....BLUE</td> <td>O.....ORANGE</td> <td>W.....WHITE</td> </tr> <tr> <td></td> <td>Y.....YELLOW</td> <td></td> </tr> </table> <p>ELECTRICAL WIRING DIAGRAM 3.0 TON GAS/ELECTRIC W/ INTEGRATED FURNACE CONTROL W/PSC BLOWER MOTOR 208/230V, 3-PHASE</p> <p>APPROVED: [Signature] MODELED BY: ZJW CHECKED: [Signature] DATE: 05-07-14 ORIGINAL RELEASE NO.: R-1059S015 PART NO.: 90-23626-23 REV: 00</p>	BK.....BLACK	G.....GREEN	PR.....PURPLE	BR.....BROWN	GY.....GRAY	R.....RED	BL.....BLUE	O.....ORANGE	W.....WHITE		Y.....YELLOW																		
		BK.....BLACK	G.....GREEN	PR.....PURPLE																										
BR.....BROWN	GY.....GRAY	R.....RED																												
BL.....BLUE	O.....ORANGE	W.....WHITE																												
	Y.....YELLOW																													
<p><b>WIRING DIAGRAM</b></p> <p>NOTE: BLOWER MOTOR WIRING CONNECTION SHOWN IN DIAGRAM BELOW IS FOR HIGH SPEED COOLING SPEED. FOR LOW SPEED COOLING SPEED, SEE DIAGRAM AT RIGHT FOR SPEED SETTINGS FOR THIS MODEL. REFER TO BLOWER AIR-FLOW PERFORMANCE CHART IN UNIT INSTALLATION INSTRUCTIONS BEFORE CHANGING FACTORY SPEED SETTING.</p> <p>NOTE: BROWN WIRE CONTINUOUSLY CONNECTED TO IFC. NOT PRESENT.</p> <p>NOTE: YELLOW WIRE CONTINUOUSLY CONNECTED TO IFC. NOT PRESENT.</p> <p>NOTE: FLAME SENSORS AND GAS VALVE MUST BE PERMANENTLY GROUNDED AND CONFORM TO I.E.C., N.E.C., C.E.C. AND NATIONAL WIRING REGULATIONS, AND LOCAL CODES AS APPLICABLE.</p> <p>NOTE: COMPRESSOR PROTECTED UNDER PRIMARY REPLACEMENT POLICY. REPLACEMENT UNITS MUST BE SAME TYPE &amp; SIZE AS ORIGINAL UNITS.</p> <p>NOTE: MAIN UNIT TRANSFORMER PRIMARY LEADS: 60 HZ, AMMONIUM BLUE-208V, BLACK-230 V. INTERCHANGE BLACK &amp; BLUE LEADS FOR 208 V TRANSFORMER OPERATION.</p> <p>NOTE: MOTORS &amp; COMPRESSOR THERMALLY PROTECTED. CONDUCTORS SUITABLE FOR USE WITH COPPER CONDUCTORS ONLY.</p> <p>NOTE: CONNECT FIELD WIRING IN GROUNDED RAIN/TIGHT CONDUIT TO 60 HZ FUSED DISCONNECT.</p> <p>NOTE: LOW VOLTAGE CIRCUIT IS N.E.C. CLASS 2 WITH CLASS 1 TRANSFORMER 24 VOLT, 50/60 HZ.</p> <p>NOTE: REPLACEMENT UNITS MUST BE SAME TYPE &amp; SIZE AS ORIGINAL UNITS.</p> <p>NOTE: COMPRESSOR PROTECTED UNDER PRIMARY REPLACEMENT POLICY. REPLACEMENT UNITS MUST BE SAME TYPE &amp; SIZE AS ORIGINAL UNITS.</p> <p>NOTE: COMPRESSOR WIRES ARE ALL BLACK FOR UNITS WITHOUT MOLDED COMPRESSOR PLUG.</p> <p>COMPONENT CODES</p> <table border="1"> <tr> <td>CC</td> <td>COMPRESSOR CONTACTOR</td> </tr> <tr> <td>CCH</td> <td>CRANKCASE HEATER</td> </tr> <tr> <td>COMP</td> <td>COMPRESSOR</td> </tr> <tr> <td>CT</td> <td>CONTROL TRANSFORMER</td> </tr> <tr> <td>FLMS</td> <td>FLAME SENSOR</td> </tr> <tr> <td>GL</td> <td>GROUND LUG</td> </tr> <tr> <td>GND</td> <td>GROUND</td> </tr> <tr> <td>GV</td> <td>GAS VALVE</td> </tr> <tr> <td>HPC</td> <td>HIGH PRESSURE CONTROL</td> </tr> <tr> <td>IBM</td> <td>INDOOR BLOWER MOTOR</td> </tr> <tr> <td>IDM</td> <td>INDUCED DRAFT MOTOR</td> </tr> <tr> <td>IFC</td> <td>INTEGRATED FURNACE CONTROL</td> </tr> <tr> <td>HCS</td> <td>HOT GAS SENSOR</td> </tr> <tr> <td>LAC</td> <td>LOW AMBIENT COOLING CONTROL</td> </tr> <tr> <td>LC</td> <td>LIMIT CONTROL</td> </tr> </table> <p>WIRING INFORMATION</p> <ul style="list-style-type: none"> <li>LINE VOLTAGE</li> <li>-FACTORY STANDARD</li> <li>-FACTORY OPTION</li> <li>-FIELD INSTALLED</li> <li>LOW VOLTAGE</li> <li>-FACTORY STANDARD</li> <li>-FIELD INSTALLED</li> </ul> <p>REPLACEMENT WIRE MUST BE THE SAME SIZE AND TYPE AND CONFORM TO I.E.C., N.E.C., C.E.C. AND NATIONAL WIRING REGULATIONS, AND LOCAL CODES AS APPLICABLE.</p>	CC	COMPRESSOR CONTACTOR	CCH	CRANKCASE HEATER	COMP	COMPRESSOR	CT	CONTROL TRANSFORMER	FLMS	FLAME SENSOR	GL	GROUND LUG	GND	GROUND	GV	GAS VALVE	HPC	HIGH PRESSURE CONTROL	IBM	INDOOR BLOWER MOTOR	IDM	INDUCED DRAFT MOTOR	IFC	INTEGRATED FURNACE CONTROL	HCS	HOT GAS SENSOR	LAC	LOW AMBIENT COOLING CONTROL	LC	LIMIT CONTROL
CC	COMPRESSOR CONTACTOR																													
CCH	CRANKCASE HEATER																													
COMP	COMPRESSOR																													
CT	CONTROL TRANSFORMER																													
FLMS	FLAME SENSOR																													
GL	GROUND LUG																													
GND	GROUND																													
GV	GAS VALVE																													
HPC	HIGH PRESSURE CONTROL																													
IBM	INDOOR BLOWER MOTOR																													
IDM	INDUCED DRAFT MOTOR																													
IFC	INTEGRATED FURNACE CONTROL																													
HCS	HOT GAS SENSOR																													
LAC	LOW AMBIENT COOLING CONTROL																													
LC	LIMIT CONTROL																													



**PRINTING INSTRUCTIONS:** MAKE EXACTLY 8.0 IN X 10.0 IN. WHITE BACKGROUND WITH BLACK PRINTING

**MATERIAL:** PRESSURE SENSITIVE, ADHESIVE BACKED LABEL

NO REVISION TO DESIGN, MATERIAL, TOOLING, OR PROCESS IS ACCEPTABLE WITHOUT PRIOR APPROVAL FROM RHEEM THROUGH AN AUTHORIZED CHANGE NOTICE. A REVISED ENGINEERING SPECIFICATION AND A REWORKING OF THE ORIGINAL DRAWING SHALL BE REQUIRED FOR ANY CHANGES. RHEEM PLUMBING, HEATING & AIR CONDITIONING DEPARTMENTS IN ANY OF OUR FACILITIES OR IN ANY OF OUR PRODUCT QUALITY, PERFORMANCE, RELIABILITY, PACKAGING, DELIVERY OR WORKMANSHIP. ANY DOCUMENTS REFERRED TO ON THIS DRAWING ARE INCLUDED IN THE SPECIFICATIONS FOR THIS COMPONENT.

**WIRING DIAGRAM**

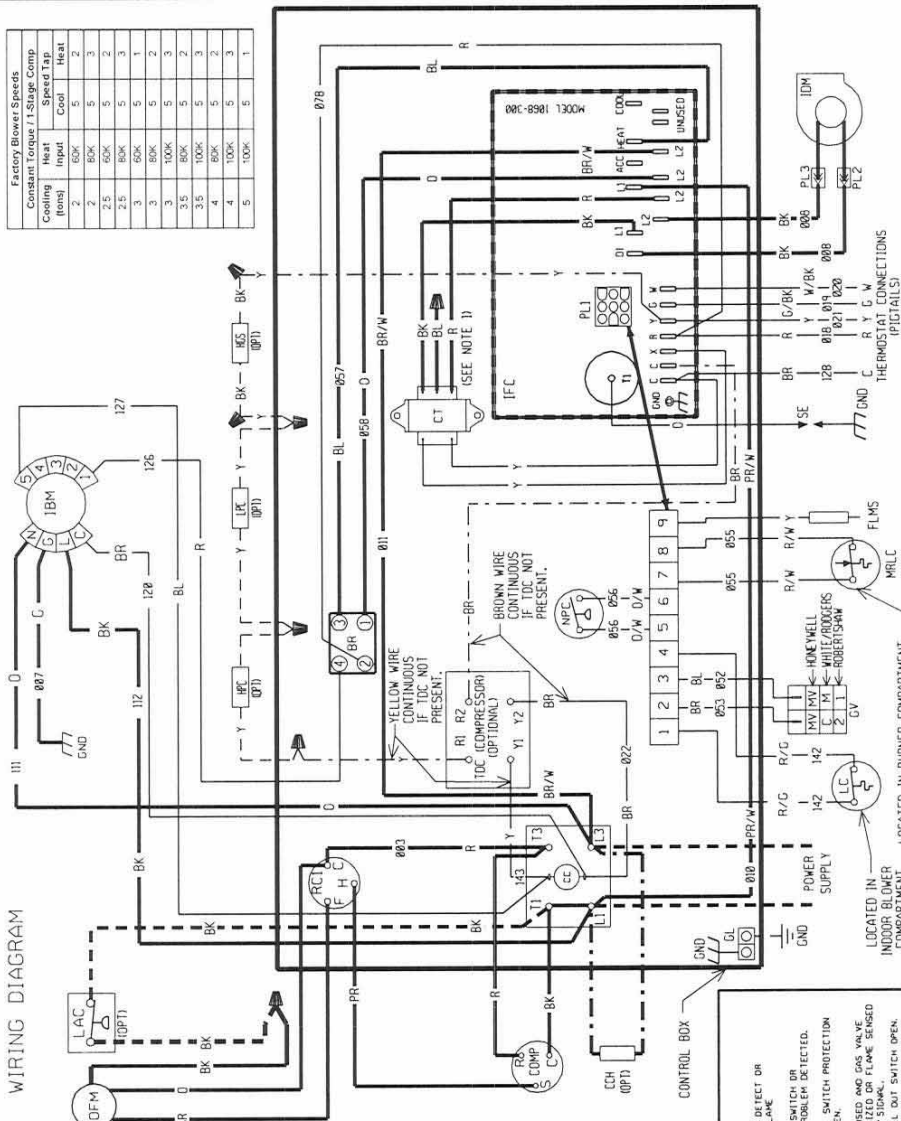

Factory Blower Specifics			
Constant Torque 1/2 Stage Comp	Constant Torque 1/2 Stage Comp	Speed	Heat
Control	Input	Control	Heat
2	600K	S	2
2	600K	S	3
2.5	600K	S	3
2.5	600K	S	3
3	600K	S	1
3	1000K	S	2
3.5	800K	S	2
3.5	1000K	S	2
4	800K	S	2
4	1000K	S	3
5	1000K	S	1

**WIRING SCHEMATIC**

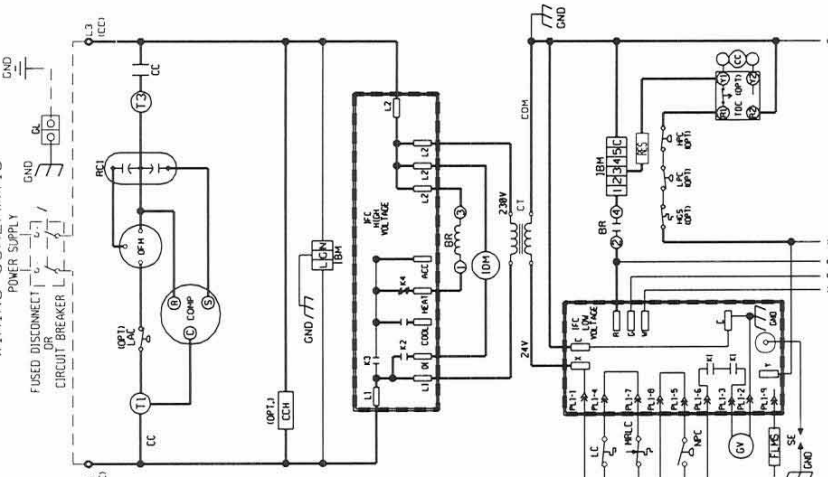

**WIRE COLOR CODE**

BK.....BLACK	G.....GREEN	PR.....PURPLE
BR.....BROWN	GY.....GRAY	R.....RED
BL.....BLUE	O.....ORANGE	W.....WHITE
	Y.....YELLOW	

ELECTRICAL WIRING DIAGRAM  
2.0 - 5.0 TON SINGLE STAGE GAS/ELECTRIC  
W/ INTEGRATED FURNACE CONTROL  
W/ CONSTANT TORQUE BLOWER MOTOR  
208/230V, 1-PHASE

**COMPONENT CODES**

- LC LIMIT CONTROL
- LPC LOW PRESSURE CONTROL
- MAN. RESET LIMIT CONTROL
- NPC NEG. PRESSURE CONTROL
- OUTDOOR FAN MOTOR
- OPTIONAL
- OPT1 PLUG
- PC RUN CAPACITOR
- SE SPARK ELECTRODE
- TDC TIME DELAY CONTROL
- WIRE NUT
- BR BLOWER RELAY
- CC COMPRESSOR CONTACTOR
- CCH CRANKCASE HEATER
- CCMP COMPRESSOR
- CT CONTROL TRANSFORMER
- FLMS FLAME SENSOR
- GL GROUND LUG
- GV GAS VALVE
- HPC HIGH PRESSURE CONTROL
- IBM INDOOR BLOWER MOTOR
- IDM INDUCED DRAFT MOTOR
- IFC INTEGRATED FURNACE CONTROL
- HDS HOT GAS SENSOR
- LAC LOW AMBIENT COOLING CONTROL

**NOTES**

1. MAIN UNIT TRANSFORMER PRIMARY LEADS: 60 HZ COMMON BLUE-208 V. BLACK-230 V. INCREASE BLACK & BLUE LEADS FOR 208 V TRANSFORMER OPERATION.
2. MOTORS & COMPRESSOR THERMALLY PROTECTED. CONNECTORS SUITABLE FOR USE WITH COPPER CONDUCTORS ONLY.
3. CONNECT FIELD WIRING IN GROUNDED PAINTIGHT CONDUCIVE FIELD WIRING USES 14-3 AWG CU. CLASS 2 TRANSFORMER 24-VOLT, 50/60 HERTZ SUPPLIED.
4. REPLACEMENT FUSES MUST BE SAME TYPE & SIZE AS ORIGINAL.

**WIRING INFORMATION**

LINE VOLTAGE  
-FACTORY STANDARD  
-FACTORY OPTION  
-FIELD INSTALLED  
LOW VOLTAGE  
-FACTORY STANDARD  
-FIELD INSTALLED  
REPLACEMENT WIRE  
MUST BE THE SAME SIZE AND TYPE OF INSULATION AS ORIGINAL. (100% MIN)

WARNING MUST BE PERMANENTLY GROUNDED AND CONFORM TO NEC, IEC AND NATIONAL WIRING REGULATIONS AND LOCAL CODES AS APPLICABLE.

- DIAGNOSTICS**
- 1 FLASH - FAILED TO DETECT OR SUSTAIN FLAME
  - 2 FLASH - PRESSURE SWITCH OR INDUCER PROBLEM DETECTED.
  - 3 FLASH - HIGH LIMIT SWITCH PROTECTION DEVICE OPEN.
  - 4 FLASH - FLAME SENSED AND GAS VALVE NOT ENERGIZED OR FLAME SENSED AND NO SIGNAL.
  - 5 FLASH - FLAME ROLL OUT SWITCH OPEN.

NO REVISION TO DESIGN, MATERIAL, TOOLING, OR PROCESS IS ACCEPTABLE WITHOUT PRIOR APPROVAL FROM RHEEM THROUGH AN AUTHORIZED CHANGE NOTICE. A REVISED ENGINEERING SPECIFICATION AND A RESAMPLED CHANGE PARTS. THE SUPPLIER IS RESPONSIBLE FOR NOTIFYING RHEEM R & D AND PURCHASING DEPARTMENTS IN WRITING OF ANY CHANGES AFFECTING THIS DRAWING. ANY CHANGES TO THIS DRAWING SHALL BE MADE IN WORKMANSHIP. ANY DOCUMENTS REFERRED TO ON THIS DRAWING ARE INCLUDED IN THE SPECIFICATIONS FOR THIS COMPONENT.

Factory Blower Speeds	Constant Torque / 1/2 Stage Comp	Heat	Cool	Heat
3	60K	5	1	
3	80K	5	2	
3	100K	5	3	
3.5	80K	5	2	
3.5	100K	5	3	
4	80K	5	2	
4	100K	5	3	
5	100K	5	1	

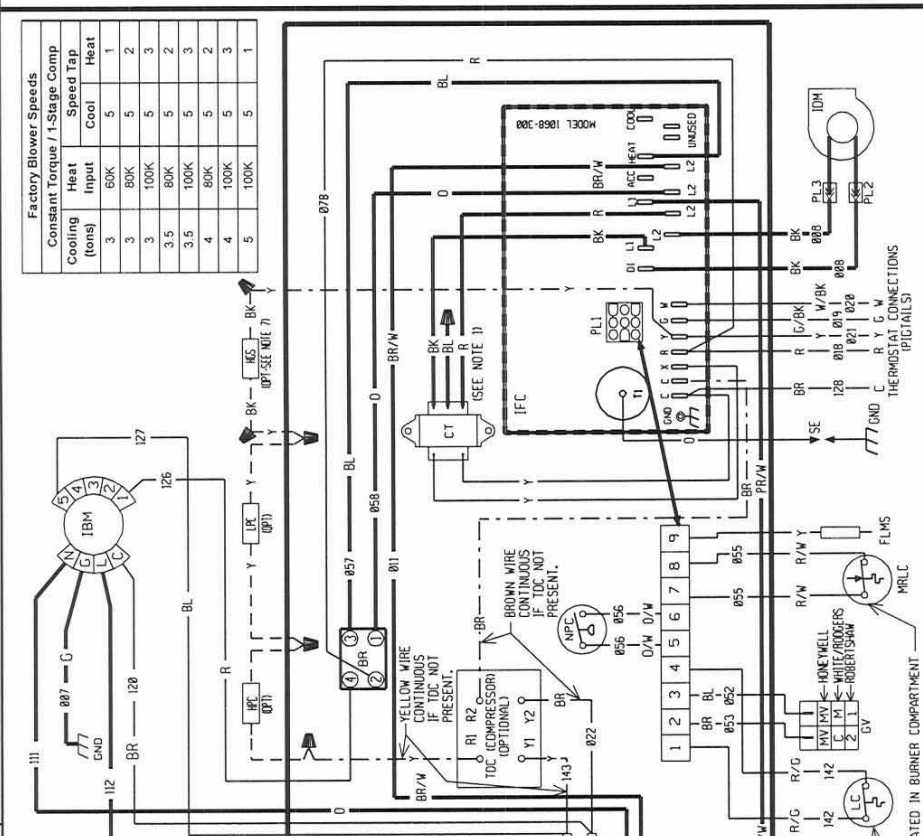
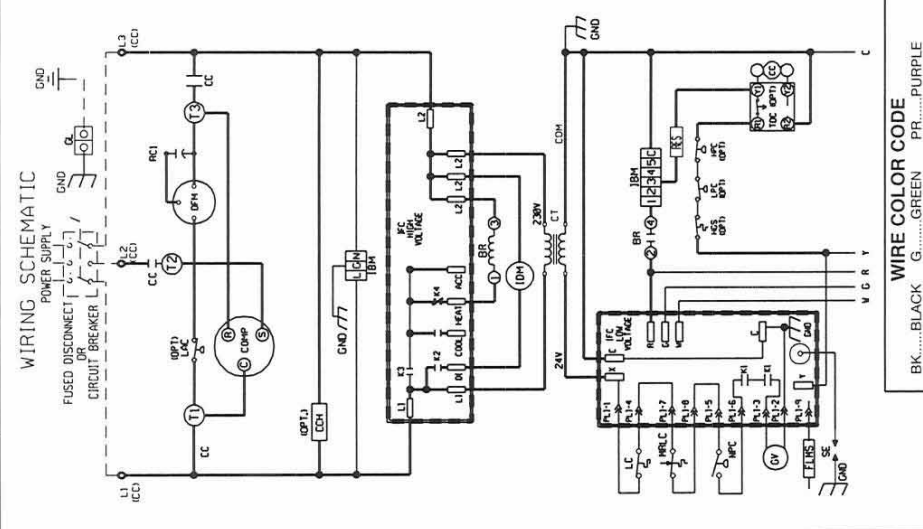

**WIRE COLOR CODE**  
BK.....BLACK G.....GREEN PR.....PURPLE  
BR.....BROWN GY.....GRAY R.....RED  
BL.....BLUE O.....ORANGE W.....WHITE  
Y.....YELLOW

**ELECTRICAL WIRING DIAGRAM**

3.0 - 5.0 TON SINGLE STAGE GAS/ELECTRIC  
W/ INTEGRATED FURNACE CONTROL  
W/ CONSTANT TORQUE BLOWER MOTOR  
208/230V, 3-PHASE

APPROVED: [Signature] CHECKED: [Signature] ORIGINAL RELEASE NO. R-1059S015  
MODELED: ZJW DATE: 05-07-14  
PART NO.: 90-23626-25 REV: 00

**COMPONENT CODES**

BR BLOWER RELAY  
CC COMPRESSOR CONTACTOR  
CCH CRANKCASE HEATER  
CDMP COMPRESSOR  
CT CONTROL TRANSFORMER  
FLMS FLAME SENSOR  
GL GROUND LUG  
GND GROUND  
GV GAS VALVE  
HPC HIGH PRESSURE CONTROL  
IBM INDOOR BLOWER MOTOR  
IDM INDUCED DRAFT MOTOR  
IFC INTEGRATED FURNACE CONTROL  
HOT GAS SENSOR  
LAC LOW AMBIENT COOLING CONTROL

**NOTES**

1. MAIN UNIT TRANSFORMER PRIMARY LEADS: 60 HZ COMMON BLUE-208 V BLACK-230 V INTERCHANGE BLACK & BLUE LEADS FOR 208 V TRANSFORMER OPERATION.
2. MOTORS & COMPRESSOR THERMALLY PROTECTED. CONNECTORS SUITABLE FOR USE WITH COPPER CONDUCT.
3. CONNECT FIELD WIRING IN GROUNDED RAINIGHT CONDUIT TO 60 HZ FUSED DISCONNECT.
4. A CLASS 2 TRANSFORMER 24 VOLT, 50/60 HERTZ SUPPLIED. FUSES MUST BE SAME TYPE & RATING AS ORIGINAL.
5. COMPRESSOR PROTECTED UNDER NATIONAL WIRING REGULATIONS, AND LOCAL CODES AS APPLICABLE.

**WIRING INFORMATION**

LINE VOLTAGE  
-FACTORY STANDARD  
-FACTORY OPTION  
-FIELD INSTALLED  
-FIELD INSTALLED  
-FACTORY STANDARD  
-FIELD INSTALLED

REPLACEMENT WIRE  
-MUST BE THE SAME SIZE AND TYPE  
OF INSULATION AS ORIGINAL (106C, MIN.)

**WARNING**  
-CABINET MUST BE PERMANENTLY GROUNDED AND CONFORM TO I.E.C., N.E.C., O.E.C. NATIONAL WIRING REGULATIONS, AND LOCAL CODES AS APPLICABLE.



NO REVISION TO DESIGN, MATERIAL, TOOLING OR PROCESS IS ACCEPTABLE WITHOUT THE APPLICABLE ENGINEERING SPECIFICATION AND A REVISION CHANGE NOTICE. A REVISED ENGINEERING SPECIFICATION AND A REVISION CHANGE PARTS. THE SUPPLIER IS RESPONSIBLE FOR NOTIFYING RHEEM R & D AND PURCHASING DEPARTMENTS IN WRITING OF ANY CHANGES AFFECTING PRODUCT QUALITY, PERFORMANCE, RELIABILITY, PACKAGING, DELIVERY OR WORKMANSHIP. ANY DOCUMENTS REFERRED TO ON THIS DRAWING ARE INCLUDED IN THE SPECIFICATIONS FOR THIS COMPONENT.

PRINTING INSTRUCTIONS: MAKE EXACTLY 8.0 IN X 10.0 IN. WHITE BACKGROUND WITH BLACK PRINTING  
MATERIAL: PRESSURE SENSITIVE, ADHESIVE BACKED LABEL

Factory Blower Speeds			
Constant Torque / 2-Stage Comp	Speed Tap		
Cooling (tons)	Heat		
Heat Input	Cool		
5 (1st stage)	100K	2	1
5 (2nd stage)	100K	5	1

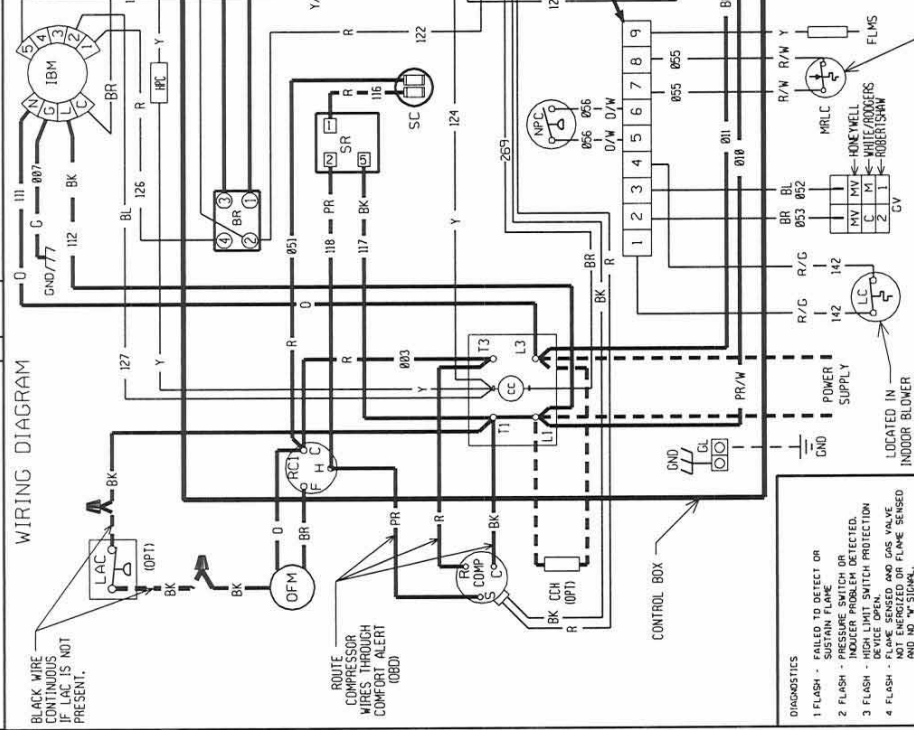
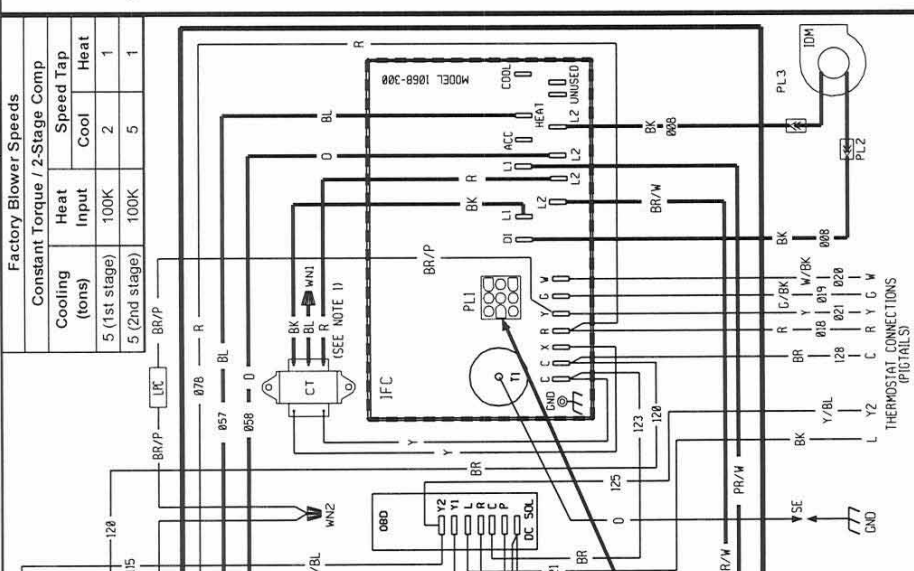
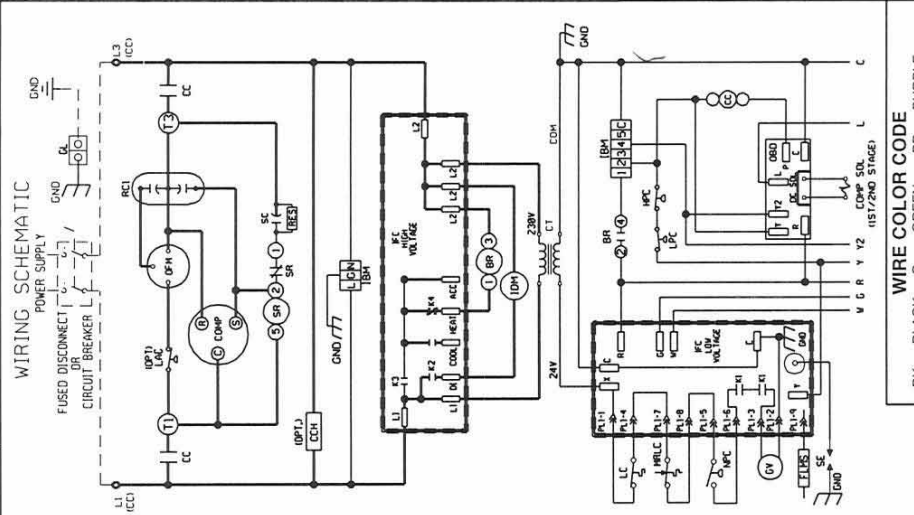

**WIRE COLOR CODE**

BK.....BLACK	G.....GREEN	PR.....PURPLE
BR.....BROWN	GY.....GRAY	R.....RED
BL.....BLUE	O.....ORANGE	W.....WHITE
		Y.....YELLOW

**ELECTRICAL WIRING DIAGRAM**

5.0 TON GAS/ELECTRIC  
W/ INTEGRATED FURNACE CONTROL  
W/ CONSTANT TORQUE BLOWER MOTOR  
W/ 2-STAGE COMPRESSOR  
208/230V, 1-PHASE

APPROVED: [Signature]  
MODELED: ZJW  
DATE: 05-07-14  
NO: R-1062S001

CHECKED: [Signature]  
DATE: 05-07-14  
NO: R-1062S001

PART NO.: 90-23626-26  
REV: 00

**COMPONENT CODES**

LC	LIMIT CONTROL
LPC	LOW PRESSURE CONTROL
MRLC	MAN. RESET LIMIT CONTROL
COMP	NEG. PRESSURE CONTROL
CT	CONTROL TRANSFORMER
FLMS	FLAME SENSOR
GL	GROUND LUG
GND	GROUND
GV	GAS VALVE
HPC	HIGH PRESSURE CONTROL
IBM	INDOOR BLOWER MOTOR
IDM	INDUCED DRAFT MOTOR
IFC	INTEGRATED FURNACE CONTROL
LAC	LOW AMBIENT COOLING CONTROL
BR	BLOWER RELAY
CC	COMPRESSOR CONTACTOR
CCH	CRANKCASE HEATER
COMP	COMPRESSOR
CT	CONTROL TRANSFORMER
FLMS	FLAME SENSOR
GND	GROUND
GV	GAS VALVE
HPC	HIGH PRESSURE CONTROL
IBM	INDOOR BLOWER MOTOR
IDM	INDUCED DRAFT MOTOR
IFC	INTEGRATED FURNACE CONTROL
LAC	LOW AMBIENT COOLING CONTROL

**NOTES**

- MAIN UNIT TRANSFORMER PRIMARY LEADS: 50 HZ COMMON BLUE-208 V BLACK-230 V INTERCHANGE BLACK & BLUE LEADS FOR 208 V TRANSFORMER OPERATION.
- MOTORS & COMPRESSOR THERMALLY PROTECTED. CONNECTORS SUITABLE FOR USE WITH COPPER CONDUCTORS ONLY.
- CONNECT FIELD WIRING IN GROUNDING RAIN TIGHT LOW VOLTAGE CIRCUITS N.E.C. CLASS 2 WITH OR INSULATION AS ORIGINAL (105C MIN)
- REPLACEMENT WIRES MUST BE SAME TYPE & SIZE AS ORIGINAL.

**WIRING INFORMATION**

DIAGNOSTICS

- FLASH - FAILED TO DETECT OR
- FLASH - PRESSURE SWITCH OR
- FLASH - INDICATOR PROBLEM DETECTED.
- FLASH - HIGH LIMIT SWITCH PROTECTION
- FLASH - FLAME SENSED AND GAS VALVE NOT ENERGIZED OR FLAME SENSED AND NO "W" SIGNAL.
- FLASH - FLAME ROLL OUT SWITCH OPEN.

LOCATED IN BURNER COMPARTMENT

LOCATED IN INDOOR BLOWER COMPARTMENT

LOCATED IN CONTROL BOX

REPLACEMENT WIRE

- FACTORY STANDARD
- FACTORY OPTION
- FIELD INSTALLED

LOW VOLTAGE

- FACTORY STANDARD
- FIELD INSTALLED

REPLACEMENT WIRE

- FACTORY STANDARD
- FIELD INSTALLED

WARNING

CABINET MUST BE PERMANENTLY GROUNDED TO THE MAIN ELECTRICAL PANEL. ALL NATIONAL WIRING REGULATIONS AND LOCAL CODES AS APPLICABLE.

**PRINTING INSTRUCTIONS:** MAKE EXACTLY 8.0 IN X 10.0 IN. WHITE BACKGROUND WITH BLACK PRINTING  
**MATERIAL:** PRESSURE SENSITIVE, ADHESIVE BACKED LABEL

**WIRING DIAGRAM**

BLACK WIRE IF LAC IS NOT PRESENT.

ROUTE COMPRESSOR WIRES THROUGH COMFORT ALERT (OBD)

- DIAGNOSTICS**
- 1 FLASH - FAILED TO DETECT OR SUSTAIN FLAME
  - 2 FLASH - PRESSURE SWITCH OR SMOKE DETECTOR
  - 3 FLASH - HONEYWELL SWITCH PROTECTION DEVICE OPEN
  - 4 FLASH - FLAME SENSE AND GAS VALVE AND NO VISIONAL
  - 5 FLASH - FLAME ROLL OUT SWITCH OPEN

**WIRING INFORMATION**

LINE VOLTAGE  
-FACTORY STANDARD  
-FACTORY OPTION  
-FIELD INSTALLED  
LOW VOLTAGE  
-FACTORY STANDARD  
-FIELD INSTALLED  
REPLACEMENT WIRE  
-MUST BE THE SAME SIZE AND TYPE OF INSULATION AS ORIGINAL (105C. MIN.)  
WARNING  
-CABINET MUST BE PERMANENTLY GROUNDED AND CONFORM TO I.E.C., N.E.C., C.E.C., NATIONAL WIRING REGULATIONS, AND LOCAL CODES AS APPLICABLE

**NOTES**

1. MAIN UNIT TRANSFORMER PRIMARY LEADS: BR/BL COMMON BLUE-208 V BLACK-230 V INTERCHANGE BLACK & BLUE LEADS FOR 208 V TRANSFORMER OPERATION.
2. MOTORS & COMPRESSOR THERMALLY PROTECTED. CONNECTORS SUITABLE FOR USE WITH COPPER CONDUCTORS ONLY.
3. CONDENSERS TO BE WIRING IN GROUNDED RAINIGHT CONDUIT TO 60 W/ FUSED DISCONNECT.
4. LOW VOLTAGE CIRCUIT IS N.E.C. CLASS 2 WITH HERTZ SUPPLIED.
5. TRANSFORMER 24 VOL 1.50/60 REPLACEMENT FUSES MUST BE SAME TYPE & SIZE AS ORIGINAL.

**COMPONENT CODES**

- BR BLOWER RELAY
- CC COMPRESSOR CONTACTOR
- CCH CRANKCASE HEATER
- CDMP COMPRESSOR
- CT CONTROL TRANSFORMER
- FLMS FLAME SENSOR
- GL GROUND LUG
- GND GROUND
- GV GAS VALVE
- HPC HIGH PRESSURE CONTROL
- IDM INDOOR BLOWER MOTOR
- IDM INDUCED DRAFT MOTOR
- IFC INTEGRATED FURNACE CONTROL
- LAC LOW AMBIENT COOLING CONTROL
- LC LIMIT CONTROL
- LPC LOW PRESSURE CONTROL
- MRLC MAN. RESET LIMIT CONTROL
- NPC NEG. PRESSURE CONTROL
- OBD ON BOARD DIAGNOSTICS
- OFM OUTDOOR FAN MOTOR
- PL PLUC
- RC RUN CAPACITOR
- SC START CAPACITOR
- SE SPARK ELECTRODE
- SR START RELAY
- WIRE NUT

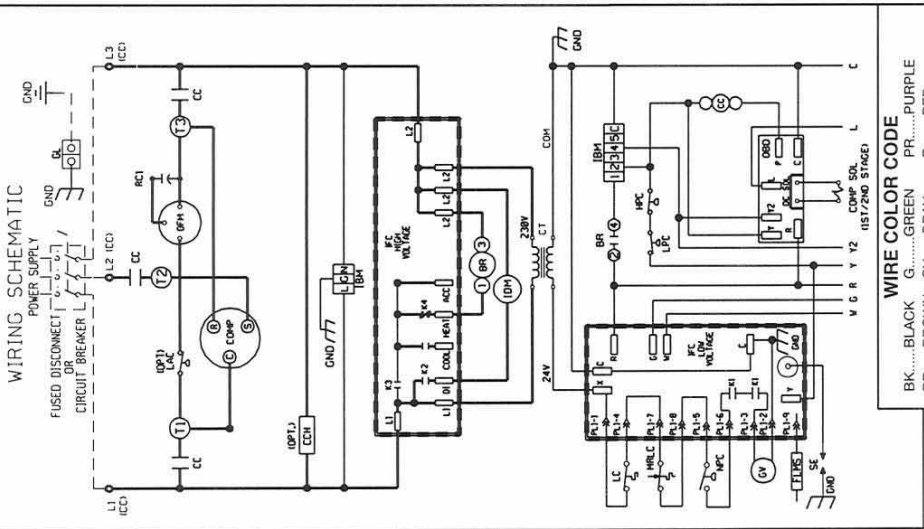
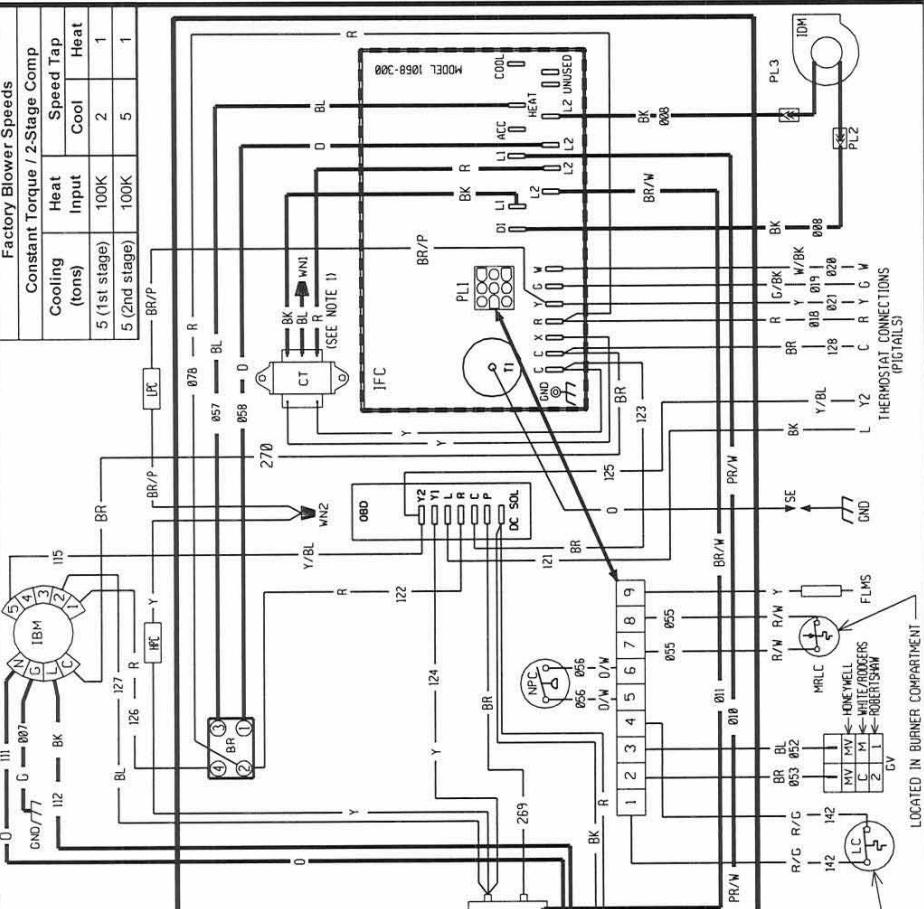

**WIRE COLOR CODE**

BK.....BLACK G.....GREEN PR.....PURPLE  
BR.....BROWN GV.....GRAY R.....RED  
BL.....BLUE O.....ORANGE W.....WHITE  
Y.....YELLOW

**ELECTRICAL WIRING DIAGRAM**

5.0 TON GAS/ELECTRIC  
W/ INTEGRATED FURNACE CONTROL  
W/ CONSTANT TORQUE BLOWER MOTOR  
W/ 2-STAGE COMPRESSOR  
208/230V, 3-PHASE

APPROVED: [Signature] CHECKED: [Signature] ORIGINAL RELEASE NO. R-1062S001  
MODELED BY: ZJW DATE: 05-07-14  
PART NO.: 90-23626-27 REV: 00



PRINTING INSTRUCTIONS: MAKE EXACTLY 8.0 IN X 10.0 IN. WHITE BACKGROUND WITH BLACK PRINTING  
MATERIAL: PRESSURE SENSITIVE, ADHESIVE BACKED LABEL

NO REVISION TO DESIGN, MATERIAL, TOOLING, OR PROCESS IS ACCEPTABLE WITHOUT PRIOR APPROVAL FROM THEEM THROUGH AN AUTHORIZED CHANGE ORDER. THE SUPPLIER IS RESPONSIBLE FOR ANY CHANGES AFFECTING PURCHASING DEPARTMENTS IN WRITING OF ANY CHANGES AFFECTING PRODUCT QUALITY, PERFORMANCE, RELIABILITY, PACKAGING, DELIVERY OR WORKMANSHIP. ANY DOCUMENTS REFERRED TO ON THIS DRAWING ARE INCLUDED IN THE SPECIFICATIONS FOR THIS COMPONENT.

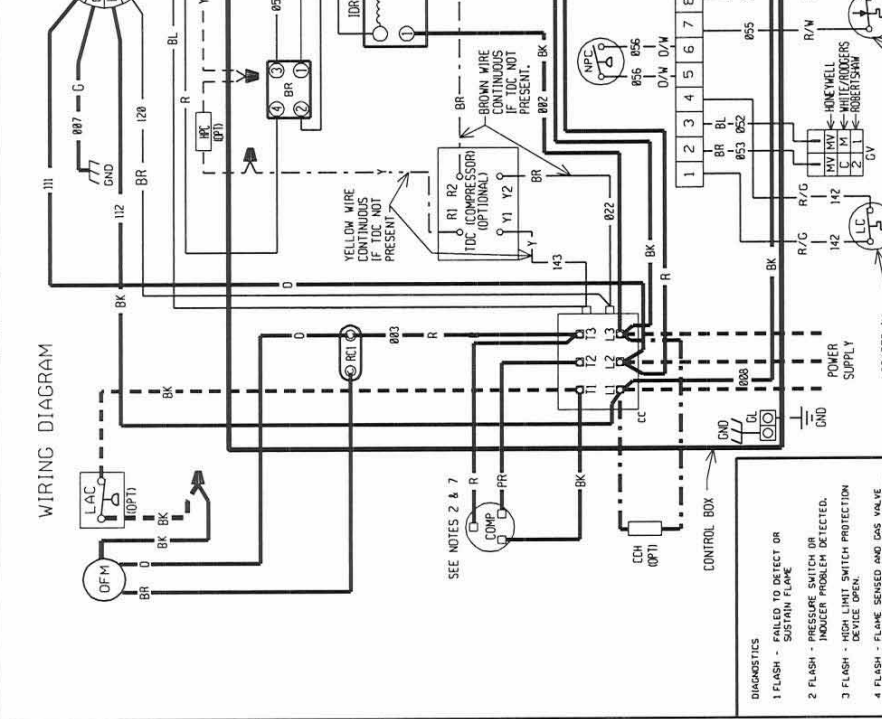
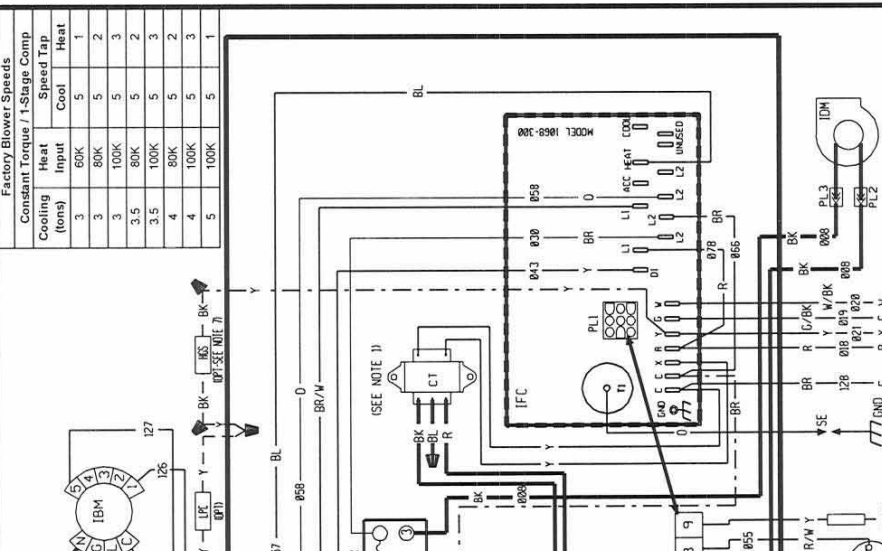
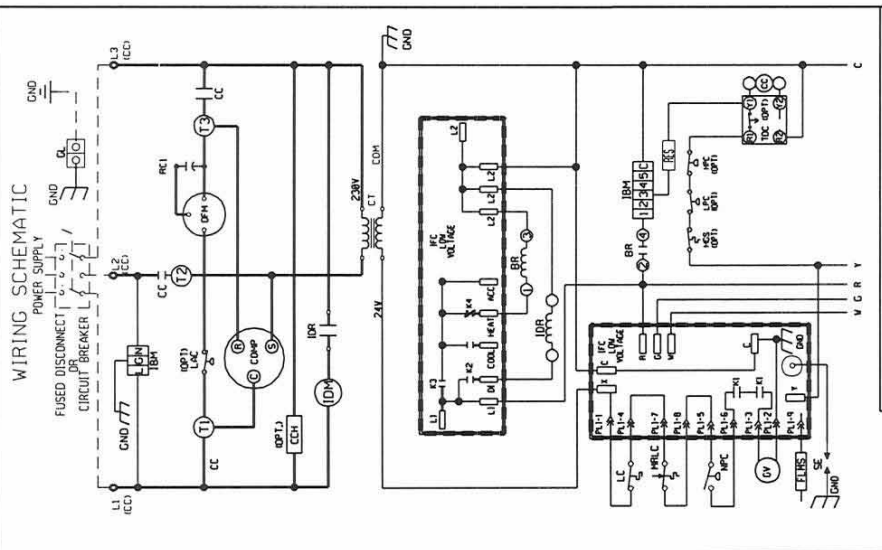

WIRE COLOR CODE

BK.....BLACK  
BR.....BROWN  
BL.....BLUE  
G.....GREEN  
GY.....GRAY  
O.....ORANGE  
PR.....PURPLE  
R.....RED  
W.....WHITE  
Y.....YELLOW

ELECTRICAL WIRING DIAGRAM

3.0 - 5.0 TON SINGLE STAGE GAS/ELECTRIC  
W/ INTEGRATED FURNACE CONTROL  
W/ CONSTANT TORQUE BLOWER MOTOR  
460V, 3-PHASE

APPROVED: [Signature]  
MODELED: ZJW  
DATE: 05-08-14  
BY: R-1059S015

CHECKED: [Signature]  
ORIGINAL RELEASE NO.:  
90-23626-28  
REV: 00

DIAGNOSTICS

- FLASH - FAILED TO DETECT OR SUSTAIN FLAME
- FLASH - PRESSURE SWITCH OR INDUCER PROBLEM DETECTED.
- FLASH - HIGH LIMIT SWITCH PROTECTION DEVICE OPEN.
- FLASH - FLAME SENSED AND GAS VALVE NOT ENERGIZED OR FLAME SENSED
- FLASH - FLAME ROLL OUT SWITCH OPEN.

WIRING INFORMATION

LINE VOLTAGE  
-FACTORY STANDARD  
-FACTORY OPTION  
-FIELD INSTALLED

LOW VOLTAGE  
-FACTORY STANDARD  
-FIELD INSTALLED

REPLACEMENT WIRE  
-USE THE SAME SIZE AND TYPE  
OR INSULATION AS ORIGINAL (106C. MIN)

WARNING  
-CABINET MUST BE PERMANENTLY GROUNDED  
-C. LEGS, C. LEGS, C. LEGS, AND LOCAL NATIONAL WIRING REGULATIONS, AND LOCAL CODES AS APPLICABLE

**PRINTING INSTRUCTIONS:** MAKE EXACTLY 8.0 IN X 10.0 IN. WHITE BACKGROUND WITH BLACK PRINTING

**MATERIAL:** PRESSURE SENSITIVE, ADHESIVE BACKED LABEL

**WIRING DIAGRAM**

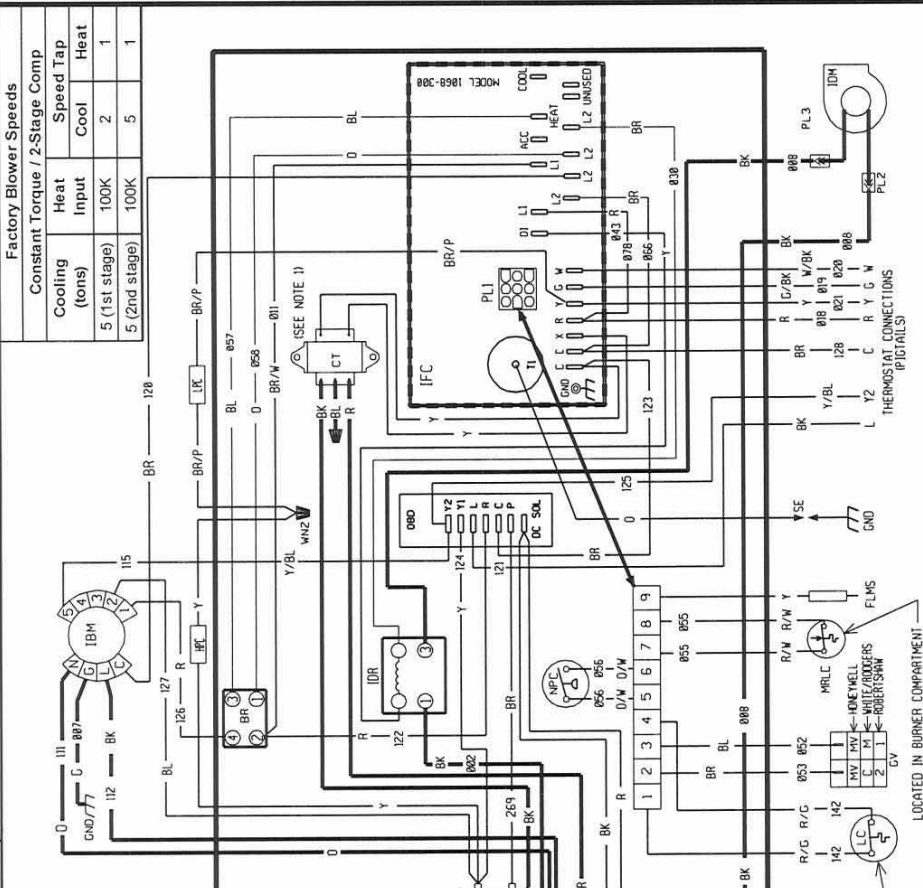

**Factory Blower Speeds**

Constant Torque / 2-Stage Comp	Heat Input	Speed Tap	Cooling (tons)
5 (1st stage)	100K	2	1
5 (2nd stage)	100K	5	1

**WIRING SCHEMATIC**

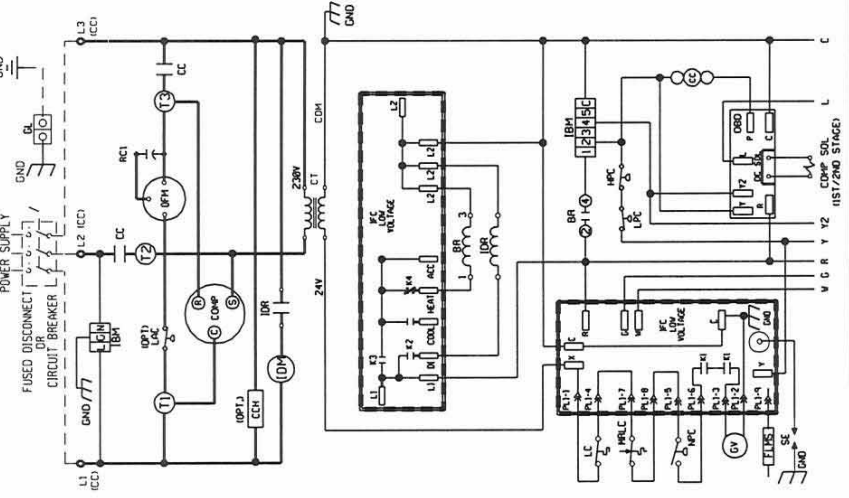

**WIRE COLOR CODE**

BK.....BLACK	G.....GREEN	PR.....PURPLE
BR.....BROWN	GY.....GRAY	R.....RED
BL.....BLUE	O.....ORANGE	W.....WHITE
		Y.....YELLOW

ELECTRICAL WIRING DIAGRAM

5.0 TON GAS/ELECTRIC  
W/ INTEGRATED FURNACE CONTROL  
W/ CONSTANT TORQUE BLOWER MOTOR  
W/ 2-STAGE COMPRESSOR

APPROVED: [Signature]  
DATE: 05-08-14  
MODELER: ZJW  
PART NO.: 90-23626-29  
REV: 00

**COMPONENT CODES**

LAC	LOW AMBIENT COOLING CONTROL
LC	LIMIT CONTROL
LPC	LOW PRESSURE CONTROL
MRLC	MAN. RESET LIMIT CONTROL
NPC	NEG. PRESSURE CONTROL
OBD	ON BOARD DIAGNOSTICS
OFM	OUTDOOR FAN MOTOR
OPT	OPTIONAL PLUG
PL	PLUG
RC	RUN CAPACITOR
SC	START CAPACITOR
SR	SPARK ELECTRODE
SR	START RELAY
IFC	INTEGRATED FURNACE CONTROL

**NOTES**

- CONTROL TRANSFORMER PRIMARY LEADS: BLUE - COMMON, RED - 575V, 60 HZ. / 415V, 50 HZ.
- COMPRESSOR MOTOR THERMALLY PROTECTED. ALL SINGLE PHASE MODELS ARE PROTECTED UNDER PRIMARY CONNECTORS SUITABLE FOR USE WITH COPPER CONDUCTORS ONLY.
- CONNECT FELD WIRING IN GROUNDED RAINTIGHT CONDUIT TO 88 HZ FUSED DISCONNECT.
- LOW VOLTAGE CIRCUIT IS N.E.C. CLASS 2 WITH CLASS 2 SUPPLIED.
- REPLACEMENT FUSES MUST BE SAME TYPE & SIZE AS ORIGINAL.

**WIRING INFORMATION**

LINE VOLTAGE  
-FACTORY STANDARD  
-FACTORY OPTION  
-FIELD INSTALLED

LOW VOLTAGE  
-FACTORY STANDARD  
-FIELD INSTALLED

REPLACEMENT WIRE  
-MUST BE THE SAME SIZE AND TYPE  
-OF INSULATION AS ORIGINAL (105C. MIN.)

WARNING  
-CABINET MUST BE PERMANENTLY GROUNDED  
AND CONFORM TO I.E.C. N.E.C. C.E.C.  
NATIONAL WIRING REGULATIONS, AND LOCAL  
CODES AS APPLICABLE



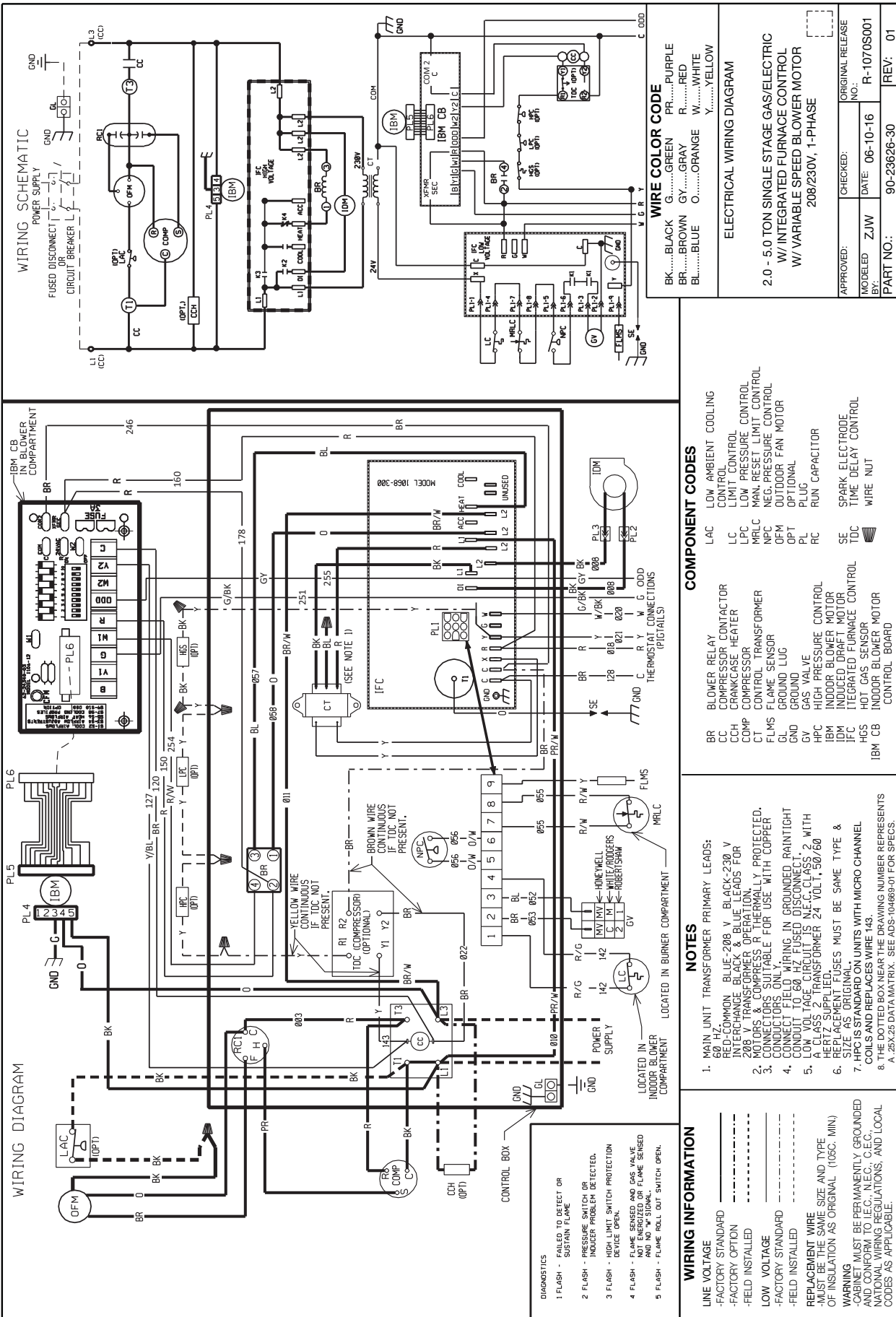

**WIRING SCHEMATIC**

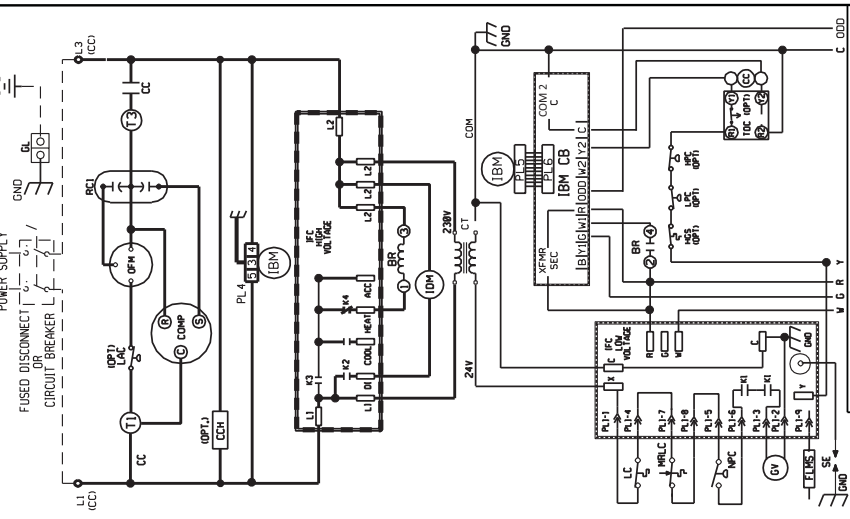

**WIRE COLOR CODE**

BK.....BLACK	G.....GREEN	PR.....PURPLE
BR.....BROWN	GY.....GRAY	R.....RED
BL.....BLUE	O.....ORANGE	W.....WHITE
	Y.....YELLOW	

ELECTRICAL WIRING DIAGRAM  
2.0 - 5.0 TON SINGLE STAGE GAS/ELECTRIC  
W/ INTEGRATED FURNACE CONTROL  
W/ VARIABLE SPEED BLOWER MOTOR  
208/230V, 1-PHASE

APPROVED:	CHECKED:	ORIGINAL RELEASE NO.:
MODELED: ZJW	DATE: 06-10-16	R-107/05001
PART NO.:	90-23626-30	REV: 01

**COMPONENT CODES**

BR	BLOWER RELAY	LAC	LOW AMBIENT COOLING CONTROL
CC	COMPRESSOR CONTACTOR	LC	LIMIT CONTROL
CCH	CRANKCASE HEATER	MRLC	MAN. RESET LIMIT CONTROL
CCM	COMPRESSOR	NPC	NEG. PRESSURE CONTROL
CT	CONTROL TRANSFORMER	OFM	OUTDOOR FAN MOTOR
FLMS	FLAME SENSOR	OPT	OPTIONAL
GL	GROUND LUG	PL	PLUG
GND	GROUND	RC	RUN CAPACITOR
GV	GAS VALVE	SE	SPARK ELECTRODE
HPC	HIGH PRESSURE CONTROL	TDC	TIME DELAY CONTROL
IBM	INDOOR BLOWER MOTOR		WIRE NUT
IDM	INDUCED DRAFT MOTOR		
IFC	INTEGRATED FURNACE CONTROL BOARD		
HGS	HOT GAS SENSOR		
IBM CB	INDOOR BLOWER MOTOR CONTROL BOARD		

**NOTES**

1. MAIN UNIT TRANSFORMER PRIMARY LEADS: RED-COMMON BLUE-208 V BLACK-230 V INTERCHANGE BLACK & BLUE LEADS FOR 208 V TRANSFORMER OPERATION.
2. MOTORS & COMPRESSOR R THERMALLY PROTECTED. CONNECTIONS SUITABLE FOR USE WITH COPPER CONNECTOR. WIRING IN GROUNDED RAIN/TIGHT CONDUIT TO 60 HZ FUSED DISCONNECT.
3. LOW VOLTAGE CIRCUIT IS N.E.C. CLASS 2 WITH A CLASS 2 TRANSFORMER 24 VOLT, 50/60 HERTZ SUPPLIED.
4. REPLACEMENT FUSES MUST BE SAME TYPE & MUST BE THE SAME SIZE AND TYPE OF INSULATION AS ORIGINAL (105C. MIN)
5. FACTS AND/OR COND. UNITS WITH MICRO CHANNEL COILS AND REPLACES WIRE #43
6. THE DOTTED BOX NEAR THE DRAWING NUMBER REPRESENTS A .25X.25 DATA MATRIX. SEE ADS-104689-01 FOR SPECS.

**WIRING INFORMATION**

- LINE VOLTAGE
- FACTORY STANDARD
  - FACTORY OPTION
  - FIELD INSTALLED
- LOW VOLTAGE
- FACTORY STANDARD
  - FIELD INSTALLED
- REPLACEMENT WIRE
- MUST BE THE SAME SIZE AND TYPE
  - MUST BE PERMANENTLY GROUNDED AND CONFORM TO I.E.C. N.E.C. C.E.C. NATIONAL WIRING REGULATIONS, AND LOCAL CODES AS APPLICABLE.

- DIAGNOSTICS**
- 1 FLASH - FAILS TO DETECT OR SUSTAIN FLAME
  - 2 FLASH - PRESSURE SWITCH OR INDOOR PROBLEM DETECTED.
  - 3 FLASH - HIGH LIMIT SWITCH PROTECTION DEVICE OPEN.
  - 4 FLASH - FLAME SENSED AND GAS VALVE AND MOTOR STOPS.
  - 5 FLASH - FLAME ROLL OUT SWITCH OPEN.

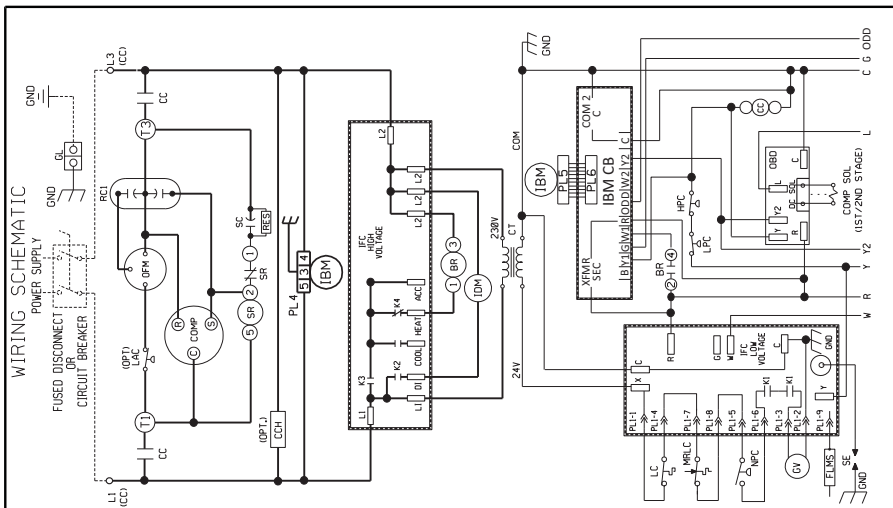

**WIRE COLOR CODE**

BK.....BLACK G.....GREEN PR.....PURPLE  
BR.....BROWN GV.....GRAY R.....RED  
BL.....BLUE O.....ORANGE W.....WHITE  
Y.....YELLOW

**ELECTRICAL WIRING DIAGRAM**

5.0 TON GAS/ELECTRIC  
W/ INTEGRATED FURNACE CONTROL  
W/ VARIABLE SPEED BLOWER MOTOR  
W/ 2-STAGE COMPRESSOR  
208/230V, 1-PHASE

APPROVED: \_\_\_\_\_ CHECKED: \_\_\_\_\_ ORIGINAL RELEASE NO.: \_\_\_\_\_  
MODELED: ZJW DATE: 06-10-16 R-10705001  
BY: \_\_\_\_\_  
PART NO.: 90-23628-31 REV: 01

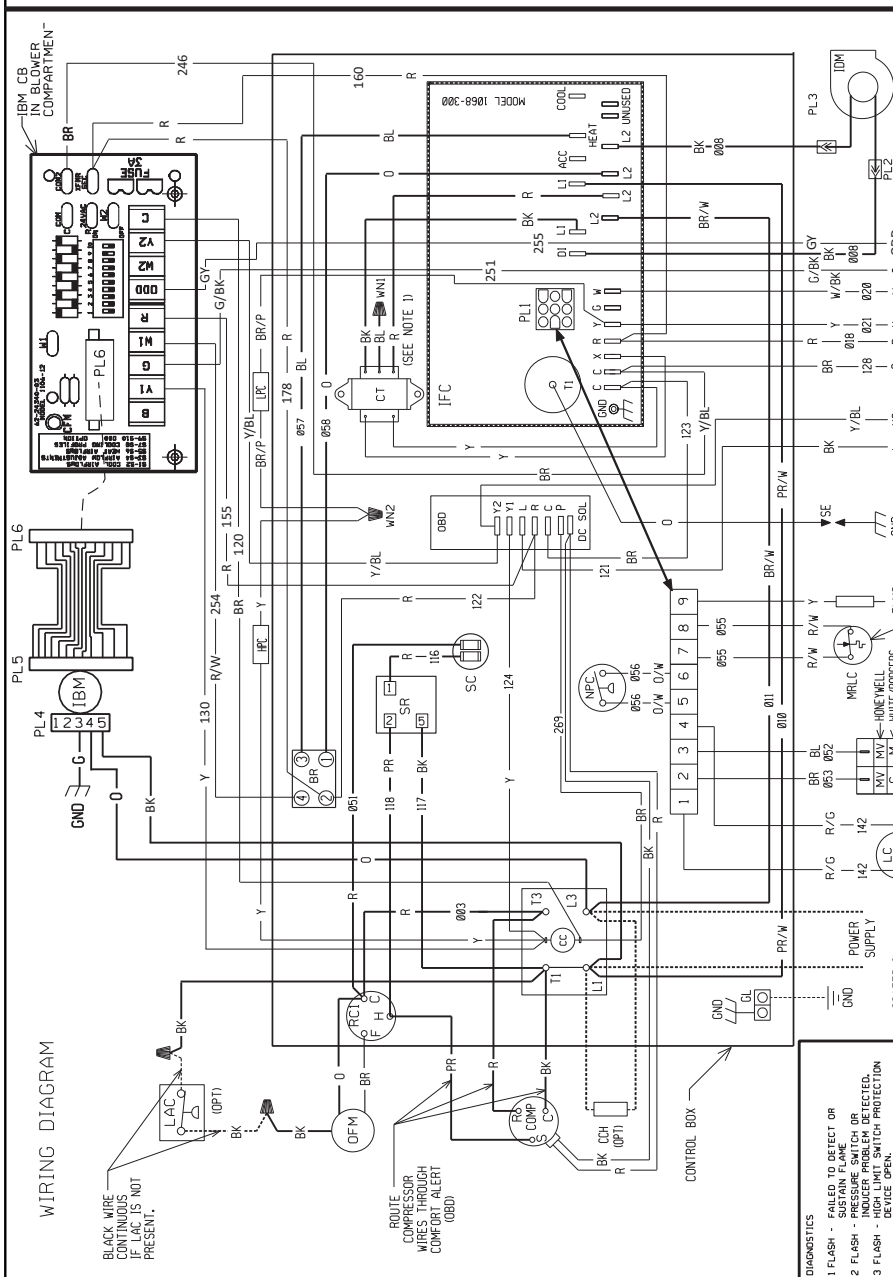

**COMPONENT CODES**

LAC LOW AMBIENT COOLING  
LC CONTROL  
LPC LIMIT CONTROL  
LPC LOW PRESSURE CONTROL  
MRLC MAN. RESET LIMIT CONTROL  
NPC NEG. PRESSURE CONTROL  
OBD ON BOARD DIAGNOSTICS  
OFM OUTDOOR FAN MOTOR  
OPT OPTIONAL  
PL PLUG  
RC RUN CAPACITOR  
SC START CAPACITOR  
SE SPARK ELECTRODE  
SR START RELAY  
WIRE NUT

BR BLOWER RELAY  
CC COMPRESSOR CONTACTOR  
CCH CRANKCASE HEATER  
COMP COMPRESSOR  
CT CONTROL TRANSFORMER  
FLMS FLAME SENSOR  
GND GROUND  
LUG GROUND LUG  
GM GAS VALVE  
HPC HIGH PRESSURE CONTROL  
IBM INDOOR BLOWER MOTOR  
IDM INDOOR DRAFT MOTOR  
IFC INTEGRATED FURNACE CONTROL  
IDM INDOOR BLOWER MOTOR  
IBM INDOOR BLOWER MOTOR  
IFC INTEGRATED FURNACE CONTROL  
IDM INDOOR BLOWER MOTOR  
IBM INDOOR BLOWER MOTOR

BR BLOWER RELAY  
CC COMPRESSOR CONTACTOR  
CCH CRANKCASE HEATER  
COMP COMPRESSOR  
CT CONTROL TRANSFORMER  
FLMS FLAME SENSOR  
GND GROUND  
LUG GROUND LUG  
GM GAS VALVE  
HPC HIGH PRESSURE CONTROL  
IBM INDOOR BLOWER MOTOR  
IDM INDOOR DRAFT MOTOR  
IFC INTEGRATED FURNACE CONTROL  
IDM INDOOR BLOWER MOTOR  
IBM INDOOR BLOWER MOTOR  
IFC INTEGRATED FURNACE CONTROL  
IDM INDOOR BLOWER MOTOR  
IBM INDOOR BLOWER MOTOR

**NOTES**

- MAIN UNIT TRANSFORMER PRIMARY LEADS: 60 HZ. RED-COMMON BLUE-208 V. BLACK-230 V. INTERCHANGE BLACK & BLUE LEADS FOR 208 V. TRANSFORMERS OPERATE ONLY PROTECTED.
- CONNECTIONS SUITABLE FOR USE WITH COPPER CONDUCTORS ONLY.
- CONNECT FIELD WIRING IN GROUNDED RAIN/TIGHT CONDUIT TO 60 HZ FUSED DISCONNECT.
- ALCLASS 60 TRANSFORMER 24 VOLT, 50/60 HZ. REPLACEMENT FUSES MUST BE SAME TYPE & SIZE AS ORIGINAL.
- THE DOTTED BOX NEAR THE DRAWING NUMBER REPRESENTS A 25X25 DATA MATRIX. SEE ADS-104669-01 FOR SPECS.

**WIRING INFORMATION**

LINE VOLTAGE  
-FACTORY STANDARD  
-FACTORY OPTION  
-FIELD INSTALLED

LOW VOLTAGE  
-FACTORY STANDARD  
-FIELD INSTALLED

REPLACEMENT WIRE SIZE AND TYPE  
-MUST BE THE SAME SIZE AND TYPE OF INSULATION AS ORIGINAL (105C. MIN.)

WARNING  
-CABINET MUST BE PERMANENTLY GROUNDED AND CONFORM TO I.E.C., N.E.C., C.E.C., NATIONAL WIRING REGULATIONS, AND LOCAL CODES AS APPLICABLE.



**BEFORE PURCHASING THIS APPLIANCE, READ IMPORTANT ENERGY COST AND EFFICIENCY INFORMATION AVAILABLE FROM YOUR RETAILER.**

### **GENERAL TERMS OF LIMITED WARRANTY\***

Rheem will furnish a replacement for any part of this product which fails in normal use and service within the applicable periods stated, in accordance with the terms of the limited warranty.

#### **Heat Exchanger**

- Factory Standard .....Ten (10) Years
- Stainless Steel/1-Phase & 3-Phase Models
- Commercial Application .....Twenty (20) Years
- Stainless Steel/1-Phase Models
- Residential Application .....Limited Lifetime

#### **Conditional Parts (Registration Required)**

- 1 Phase, Residential Applications .....Ten (10) Years

#### **Compressor**

- 1 Phase, Residential Applications .....Ten (10) Years
- 1 & 3 Phase, Commercial Applications .....Five (5) Years

#### **Parts**

- Commercial Applications .....One (1) Year

**\*For complete details of the Limited and Conditional Warranties, including applicable terms and conditions, contact your local contractor or the Manufacturer for a copy of the product warranty certificate.**







The new degree of comfort.™

*In keeping with its policy of continuous progress and product improvement, Rheem reserves the right to make changes without notice.*

Rheem Heating, Cooling & Water Heating • P.O. Box 17010  
Fort Smith, Arkansas 72917 • [www.rheem.com](http://www.rheem.com)

Rheem Canada Ltd./Ltée • 125 Edgeware Road, Unit 1  
Brampton, Ontario • L6Y 0P5



INTEGRATED HOME COMFORT

PRINTED IN U.S.A. 2/17 QG FORM NO. R11-870 REV. 3