

SPEED TAP TABLE (BLUE MOTOR LEAD)

TONS	LO SPEED	HIGH SPEED
1.5	T2	T3
2	T4	T5
2.5	T2	T3
3	T4	T5
3.5	T2	T3
4	T4	T5
5	T4	T5

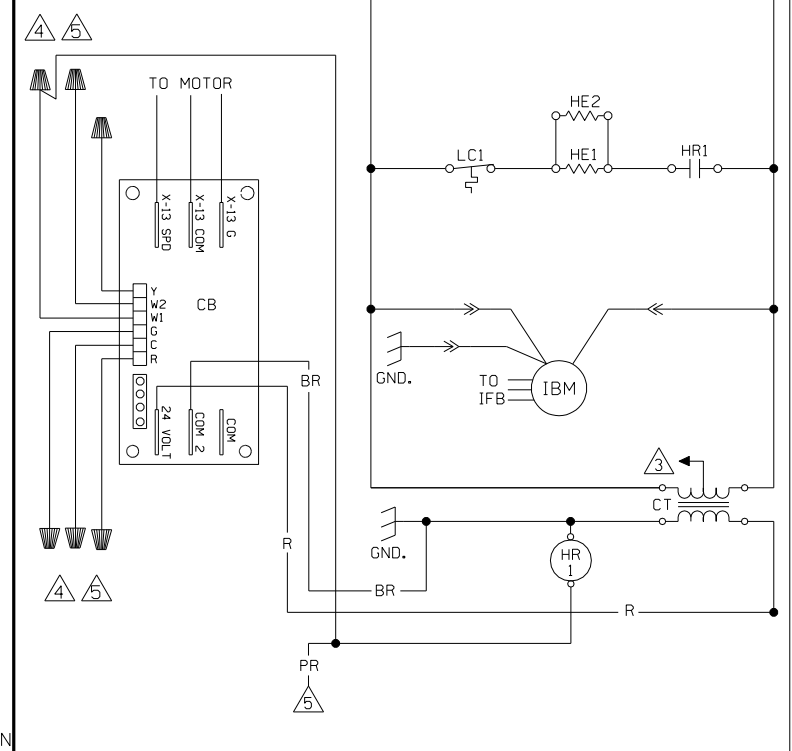

WIRING DIAGRAM REPRESENTS MAXIMUM COMPONENTS, FEWER COMPONENTS WILL RESULT IN LESS WIRING THAN SHOWN

COMPONENT CODE

- C MOTOR CONTROL PLUG
- CB CIRCUIT BREAKER
- CT CONTROL TRANSFORMER
- DHC DEFROST HEATER CONTROL
- GND GROUND
- HE HEATER ELEMENT
- HR HEATER RELAY
- IBM INDOOR BLOWER MOTOR
- LC LIMIT CONTROL
- P MOTOR POWER PLUG
- TB TERMINAL BLOCK (HI VOLT)
- WR WATT RESTRICTOR
- ▲ WIRE NUT

NOTES:

- ① CONNECT SUPPLY WIRING FOR VOLTAGE, PHASE AND HERTZ SHOWN ON RATING PLATE.
- ② SUPPLY WIRE MUST BE RATED AT 75° C MIN. SEE INSTRUCTIONS FOR SIZE.
- ③ CT FACTORY WIRED FOR 240 VOLTS. USE 0 & BL FOR 208 VOLTS.
- ④ CONTROL WIRING TO THERMOSTAT SUB-BASE.
- ⑤ CONTROL WIRING TO OUTDOOR UNIT.
- ⑥ FOR USE WITH COPPER CONDUCTORS ONLY.

WIRING INFORMATION

- LINE VOLTAGE
- FACTORY STANDARD \_\_\_\_\_
  - FACTORY OPTION - - - - -
  - FIELD INSTALLED - - - - -
- LOW VOLTAGE
- FACTORY STANDARD \_\_\_\_\_
  - FACTORY OPTION - - - - -
  - FIELD INSTALLED - - - - -
- REPLACEMENT WIRE
- MUST BE THE SAME SIZE AND TYPE OF INSULATION AS ORIGINAL (105 C° MIN.)
- WARNING
- CABINET MUST BE PERMANENTLY GROUNDED AND CONFORM TO I.E.C., N.E.C., C.E.C. AND LOCAL CODES AS APPLICABLE.

WIRE COLOR CODE

- |    |       |    |        |   |        |
|----|-------|----|--------|---|--------|
| BK | BLACK | GY | GRAY   | R | RED    |
| BR | BROWN | O  | ORANGE | W | WHITE  |
| BL | BLUE  | PK | PINK   | Y | YELLOW |
| G  | GREEN | PR | PURPLE |   |        |

ELECTRICAL WIRING DIAGRAM

J06S