

AIR HANDLERS

R-410A
factory charging

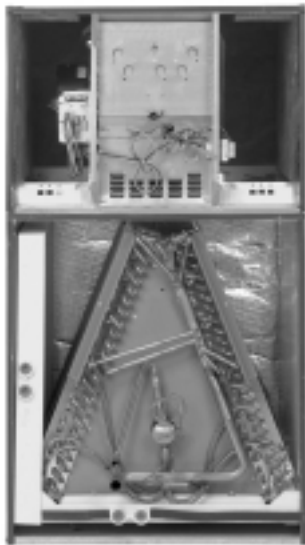

RBHM- SERIES AIR HANDLERS AND FAN COIL UNIT

Features

- Versatile 3-way convertible design for upflow, horizontal left and horizontal right.
- Available from the factory in upflow and horizontal left configurations.
- Nominal airflow up to 1.0" external static pressure.
- Standard factory installed high-efficiency coils.
- The blower box is made of sturdy steel construction with 1 inch [25.4 mm] of foil faced insulation for excellent sound and insulating characteristics.
- Designed for use with exterior high-static filters.
- Circuit breaker (standard on units with more than 11 kW) meets U.L. and cUL requirements for service disconnect.
- Factory installed electric heat provides exact heat for indoor comfort over a variety of applications.
- Dip switch settings for selectable, customized cooling airflow over a wide variety of applications.
- On-demand dehumidification-terminal that adjusts airflow to help control humidity for unsurpassed comfort in cooling mode.



Engineering Features

RBHM- Series

- Quiet, energy efficient ECM motor technology providing nominal airflow to 1.0 inch [25 kPa] of external static pressure.
- Interface board with dip switches conveniently located in the blower compartment allows for precise, field selectable airflow to meet the requirements of particular applications.
- Selectable continuous fan “on” options.
- Attractive pre-painted cabinet exterior.
- The blower box has rugged steel cabinet construction, designed for added strength and versatility.
- 1" foil faced insulation mechanically retained in blower compartment.
- Four leg, rubber insulated wire motor mount.
- Circuit breakers standard on 1-phase models above 11 kW and optional on models with 11 kW or less.
- Models supplied with circuit breakers meet UL and CUL requirements as a service disconnect switch.
- Provisions for field electrical connections from either side of air handler cabinet.
- Tab lock blower housing with integrated electric heaters, controls, motor and blower. Slide out design for service and maintenance convenience.

- Exclusive dependable Incoloy sheath type electric heating elements located in the blower housing provide mixed warm air.
- Field convertible for vertical upflow, horizontal left hand or right hand air supply.
- Indoor coil design provides low air side pressure drop and high performance. All coils come with PVC condensate elbow standard.
- All indoor coils have copper tubing and aluminum fins.
- Molded polymer corrosion resistant condensate drain pan is provided on all indoor coils.
- Both supply and return duct flanges provided as standard on air handler cabinet.
- Connection points for both high voltage and low voltage control wiring inside air handler cabinet.
- Concentric knockouts are provided for power connection to cabinet. Installer may pull desired hole size up to 2 inches [51 mm] for 1 1/2 inch [38 mm] conduit.
- Front refrigerant and drain connections.

[] Designates Metric Conversions

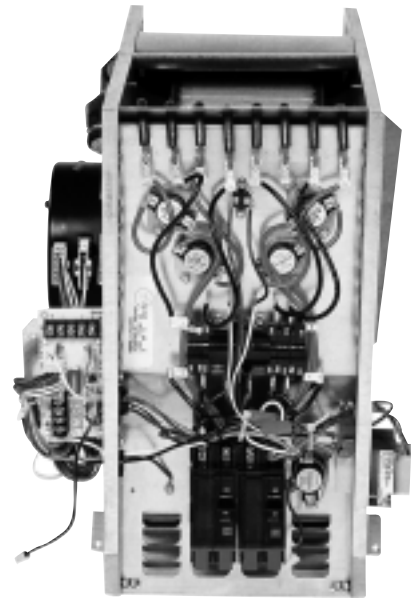
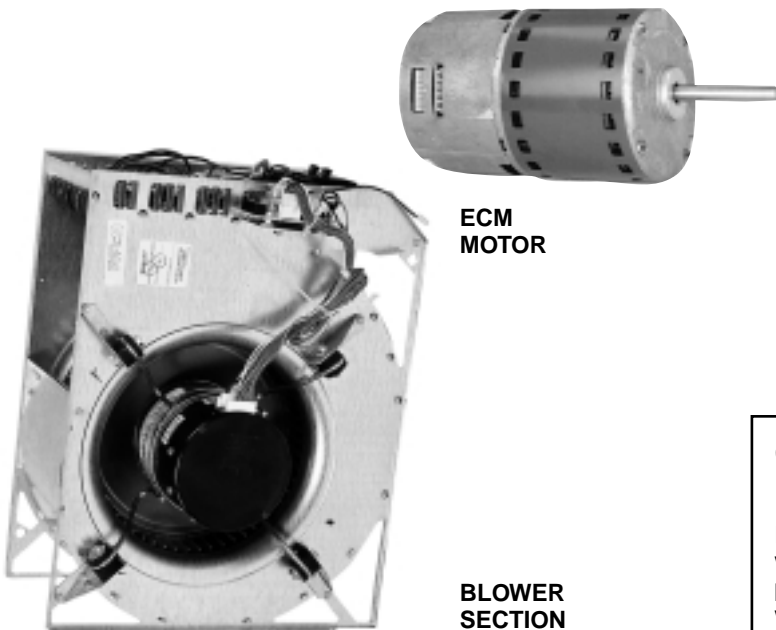

GENERAL TERMS OF LIMITED WARRANTY

Ruud will furnish a replacement for any part of this product which fails in normal use and service within the applicable periods stated, in accordance with the terms of the limited warranty.

Limited Parts Warranty.....Ten (10) Years

For Complete Details of the Limited Warranty, Including Applicable Terms and Conditions, See Your Local Installer or Contact the Manufacturer for a Copy.

Model Identification

R	B	H	M	17	J	11	S	M	Q	Additional Inform.
Ruud	Blower Unit	Type Unit	Design Series	Cab. Width	Electrical Designations	Electrical Heat (KW) Designation See Electrical Heat Data for Actual KW at 208 Volts.	Control Designation	Airflow Direction	Coil Code	1) Motor H.P. [W] 2) Blower CFM [L/s] 1st/2nd Stage 3) Blower Wheel Dia./Width [mm] 4) Filter Size Width/Length [mm] 5) Outdoor Unit Size
		H = Air Handler		17 24 25 26	J = 208/240V, 1PH, 60HZ	00 = No Heat 06 = 4.9 kW 07 = 7.0 kW 11 = 10.0 kW 14 = 14.0 kW	N = No Circuit Breakers Single Supply Circuit S = Circuit Breaker(s) Single Supply Circuit	M = Multiposition		
				17 = 17.5"	J	00, 06, 07, 11	N		Q = RCQD-2417AS	1) 1/3 H.P. [249] 2) 600/800 CFM [283/378] 3) 11 ²⁹ / ₃₂ x 3 ¹³ / ₁₆ [302 x 96] 4) N/A† 5) -024
				24 = 24.5"	J	06, 07, 11	S		R = RCQD-3624AS	1) 1/2 H.P. [373] 2) 900/1200 CFM [425/566] 3) 11 ²⁹ / ₃₂ x 7 ¹ / ₈ [302 x 181] 4) N/A† 5) -036
				25 = 24.5"	J	00, 07, 11	N	M = Multiposition	S = RCQD-4824AS	1) 3/4 H.P. [559] 2) 1200/1600 CFM [566/755] 3) 11 ²⁹ / ₃₂ x 9 ¹ / ₂ [302 x 241] 4) N/A† 5) -048
				26 = 24.5"	J	11, 14, 18	S		T = RCQD-6024AS	1) 1 H.P. 2) 1275/1700 CFM [602/802] 3) 11 ²⁹ / ₃₂ x 9 ¹ / ₂ [302 x 241] 4) N/A† 5) -060
						11	N			
						11, 14, 18, 21	S			

- NOTES:** 1) RBHM Air Handler cannot be ordered without coil.
 2) Electrical heat designation: set electric heat data for actual heater kW represented by number above.
 3) Electric heater BTUH = (heater watts + motor watts) x 3.412 (See airflow table for motor watts).
 4) †Air Handlers with A-Coils do not come with a factory installed air filter. External filter rack or other means of filtration is required.

[] Designates Metric Conversions

Unit Dimensions

3/4" [19 mm] DUCT FLANGE SUPPLIED ON RETURN AND SUPPLY DUCT OPENING

HIGH VOLTAGE CONNECTION 7/8" [22 mm], 1 3/32" [28 mm] DIA. CONCENTRIC KNOCK OUTS. IF LARGER REQUIRED, PULL HOLE SIZE REQ'D UP TO 2" [51 mm] DIA. FOR 1 1/2" [38 mm] CONDUIT

LOW VOLTAGE CONNECTION 1/2" [12.5 mm] KNOCK OUT

UPFLOW UNIT SHOWN: UNIT MAY BE INSTALLED UPFLOW, HORIZONTAL RIGHT OR LEFT HAND AIR SUPPLY.

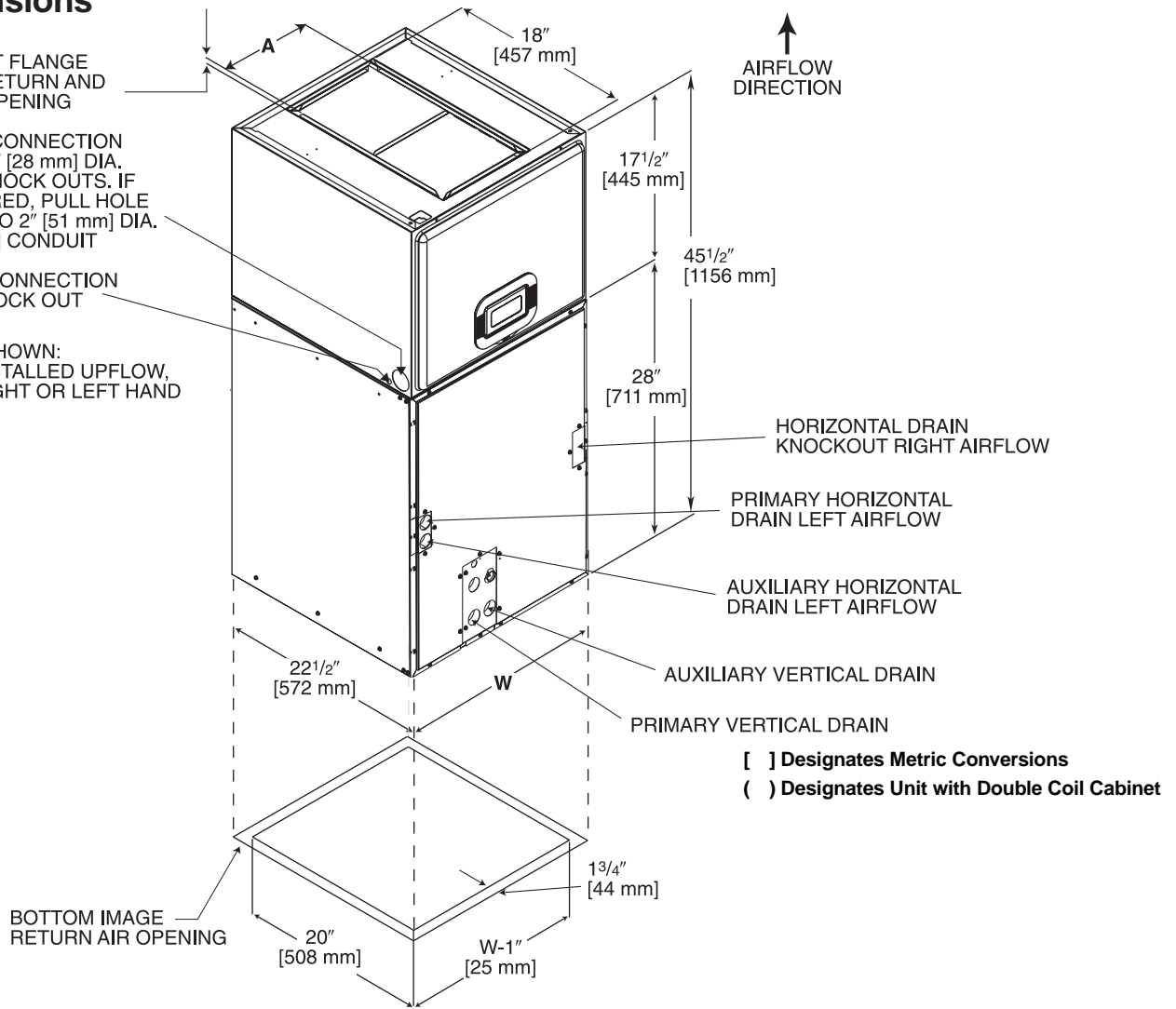

FRONT VIEW

AIRFLOW ↑

3/4" [19.1 mm] NPT DRAIN (SECONDARY)
3/4" [19.1 mm] NPT DRAIN (PRIMARY)

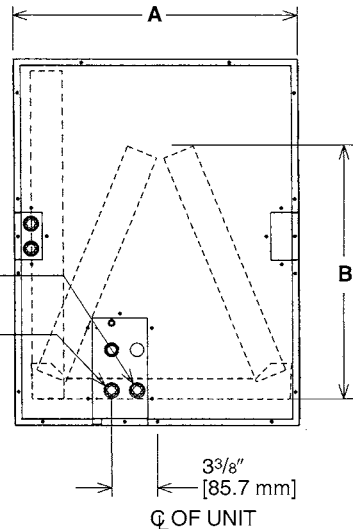

SIDE VIEW

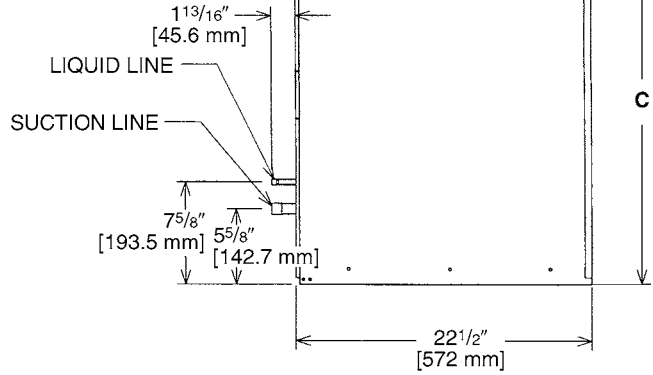

Unit Dimensions & Weights

Model Number RBHM- (with RCQD coil)	Unit Width "W" In. [mm]	Supply Duct "A" In. [mm]	Nominal Coil Airflow Stage				Unit Weight/Shipping Weight (Lbs.) [kg]
			1st		2nd		Unit With Coil (Max. KW)
			ODD	Normal	ODD	Normal	
17	17 1/2 [445]	7 9/16 [192]	450	600	600	800	136/143 [62/65]
24	24 1/2 [622]	11 3/4 [298]	720	900	960	1200	190/199 [86/90]
25	24 1/2 [622]	11 3/4 [298]	960	1200	1280	1600	196/205 [89/93]
26	24 1/2 [622]	11 3/4 [298]	1050	1275	1350	1700	197/206 [89/93]

Airflow Performance

Airflow performance data is based on cooling performance with dry coil and filter in place. Select performance table for appropriate unit size, voltage and number of electric heaters to be used. Make sure external static applied to unit allows operation within the minimum and maximum limits shown in table below for both cooling and electric heat operation. For optimum blower performance, operate the unit in the .2" to .5" in. W.C.

external static range. In general, the indoor motor speed tap should be as shown in table for the appropriate cooling capacity shown. Always check to make sure proper motor speed tap is connected as units are shipped from the factory connected for high speed operation.

Airflow Performance Data

Model Cabinet Size	Electric Heaters	Blower Motor		CFM [L/s] (Watts)/External Static Pressure—Inches W.C. [kPa]										
		Volts	Thermostat Input	0.1 [.02]	0.2 [.05]	0.3 [.07]	0.4 [.10]	0.5 [.12]	0.6 [.15]	0.7 [.17]	0.8 [.20]	0.9 [.23]	1.0 [.25]	
RBHM17 2 ton -17	3 (Max.)	208	Y1	CFM	585 [276]	588 [278]	589 [278]	590 [278]	589 [278]	588 [278]	585 [276]	582 [275]	577 [272]	572 [270]
				RPM	552	610	667	725	782	840	898	955	1013	1070
				WATTS	59	76	93	110	127	144	161	179	197	214
			Y2	CFM	792 [374]	795 [375]	797 [376]	798 [377]	797 [376]	795 [375]	791 [373]	786 [371]	779 [368]	771 [364]
				RPM	684	731	777	824	870	917	963	1009	1056	1102
				WATTS	135	156	177	197	218	238	259	279	299	319
		230	Y1	CFM	585 [276]	590 [278]	593 [280]	595 [281]	595 [281]	594 [280]	592 [279]	589 [278]	585 [276]	579 [273]
				RPM	557	615	673	731	788	846	904	961	1019	1077
				WATTS	67	82	98	114	131	148	166	184	203	222
			Y2	CFM	786 [371]	790 [373]	793 [374]	795 [375]	795 [375]	794 [375]	792 [374]	788 [372]	783 [370]	777 [367]
				RPM	664	713	762	811	861	910	959	1009	1058	1107
				WATTS	131	151	172	193	214	236	258	281	304	328
	None	208	Y1	CFM	606 [286]	609 [287]	611 [288]	611 [288]	609 [287]	606 [286]	602 [284]	596 [281]	589 [278]	580 [274]
				RPM	549	605	660	716	772	828	884	940	996	1052
				WATTS	60	77	95	112	129	146	163	179	196	212
			Y2	CFM	819 [387]	821 [387]	822 [388]	821 [387]	819 [387]	815 [385]	809 [382]	802 [379]	793 [374]	782 [369]
				RPM	681	724	768	812	855	899	943	986	1030	1074
				WATTS	136	156	175	194	213	232	251	270	288	307
		230	Y1	CFM	613 [289]	614 [290]	614 [290]	613 [289]	611 [288]	608 [287]	605 [286]	600 [283]	595 [281]	589 [278]
				RPM	545	601	657	712	768	824	879	935	991	1046
				WATTS	55	74	93	111	129	146	163	179	195	210
			Y2	CFM	819 [387]	821 [387]	823 [388]	822 [388]	821 [387]	817 [386]	812 [383]	806 [380]	798 [377]	789 [372]
				RPM	677	721	765	809	853	897	941	985	1029	1073
				WATTS	139	156	173	191	210	230	249	270	291	313
RBHM24 3 ton -24	3 (Max.)	208	Y1	CFM	870 [411]	876 [413]	881 [416]	883 [417]	883 [417]	881 [416]	877 [414]	871 [411]	863 [407]	852 [402]
				RPM	496	551	607	663	718	774	829	885	941	996
				WATTS	71	95	119	143	167	191	215	239	264	288
			Y2	CFM	1147 [541]	1163 [549]	1175 [555]	1183 [558]	1187 [560]	1187 [560]	1183 [558]	1175 [555]	1163 [549]	1148 [542]
				RPM	544	598	653	707	762	816	871	925	980	1034
				WATTS	115	154	192	229	264	298	331	362	391	419
		230	Y1	CFM	867 [409]	874 [412]	880 [415]	884 [417]	886 [418]	885 [418]	883 [417]	879 [415]	872 [412]	864 [408]
				RPM	489	547	604	661	719	776	833	890	948	1005
				WATTS	74	98	122	147	172	198	223	249	275	301
			Y2	CFM	1139 [538]	1158 [547]	1172 [553]	1182 [558]	1189 [561]	1191 [562]	1189 [561]	1184 [559]	1174 [554]	1160 [547]
				RPM	550	604	657	710	764	817	870	924	977	1030
				WATTS	124	162	198	234	269	302	334	365	395	424
	None	208	Y1	CFM	880 [415]	888 [419]	895 [422]	900 [425]	903 [426]	906 [428]	906 [428]	905 [427]	903 [426]	899 [424]
				RPM	451	506	560	615	670	725	779	834	889	944
				WATTS	65	87	108	129	151	172	194	215	236	258
			Y2	CFM	1127 [532]	1151 [543]	1171 [553]	1186 [560]	1196 [564]	1202 [567]	1204 [568]	1201 [567]	1194 [564]	1183 [558]
				RPM	514	564	614	664	714	764	813	863	913	963
				WATTS	126	153	180	207	235	263	292	321	351	381
		230	Y1	CFM	881 [416]	891 [421]	899 [424]	906 [428]	911 [430]	914 [431]	916 [432]	916 [432]	914 [431]	910 [429]
				RPM	448	503	559	614	670	725	780	836	891	947
				WATTS	63	83	104	126	149	172	196	222	247	274
			Y2	CFM	1134 [535]	1158 [547]	1178 [556]	1194 [564]	1205 [569]	1212 [572]	1214 [573]	1213 [572]	1206 [569]	1196 [564]
				RPM	509	559	610	660	711	761	812	862	913	964
				WATTS	124	151	177	205	233	262	292	323	354	386

IMPORTANT: Observe airflow operating limits. Do not operate above 1.0 in. W.C. system external static.

[] Designates Metric Conversions

Airflow Performance Data

Model Cabinet Size	Electric Heaters	Blower Motor			CFM [L/s] (Watts)/External Static Pressure—Inches W.C. [kPa]									
		Volts	Thermostat Input		0.1 [.02]	0.2 [.05]	0.3 [.07]	0.4 [.10]	0.5 [.12]	0.6 [.15]	0.7 [.17]	0.8 [.20]	0.9 [.23]	1.0 [.25]
RBHM25 4 ton -25	6 (Max.)	208	Y1	CFM	1182 [558]	1184 [559]	1184 [559]	1181 [557]	1177 [555]	1170 [552]	1160 [547]	1149 [542]	1134 [535]	1118 [528]
				RPM	545	599	653	708	762	816	871	925	979	1033
				WATTS	133	162	193	223	255	286	319	352	385	419
			Y2	CFM	1554 [733]	1567 [740]	1576 [744]	1583 [747]	1586 [749]	1586 [749]	1583 [747]	1577 [744]	1568 [740]	1556 [734]
				RPM	634	680	726	772	818	864	910	956	1002	1048
				WATTS	235	286	333	378	420	460	496	530	562	591
		230	Y1	CFM	1186 [560]	1190 [562]	1191 [562]	1190 [562]	1185 [559]	1179 [556]	1169 [552]	1157 [546]	1143 [539]	1125 [531]
				RPM	546	600	654	709	763	818	872	926	981	1035
				WATTS	126	162	196	230	264	296	328	359	389	419
			Y2	CFM	1566 [739]	1579 [745]	1588 [749]	1595 [753]	1598 [754]	1598 [754]	1595 [753]	1589 [750]	1579 [745]	1567 [740]
				RPM	630	676	722	769	815	861	907	954	1000	1046
				WATTS	241	287	332	376	418	458	497	534	571	605
	None	208	Y1	CFM	1200 [566]	1202 [567]	1204 [568]	1204 [568]	1204 [568]	1203 [568]	1201 [567]	1198 [565]	1195 [564]	1191 [562]
				RPM	478	530	582	633	685	737	789	841	893	945
				WATTS	117	139	162	186	212	240	269	299	331	364
			Y2	CFM	1558 [735]	1571 [741]	1581 [746]	1590 [750]	1597 [754]	1602 [756]	1604 [757]	1605 [757]	1604 [757]	1601 [756]
				RPM	578	621	664	707	750	792	835	878	921	964
				WATTS	220	252	284	318	352	386	421	457	494	531
		230	Y1	CFM	1202 [567]	1205 [569]	1207 [570]	1207 [570]	1207 [570]	1206 [569]	1204 [568]	1201 [567]	1197 [565]	1192 [563]
				RPM	480	532	584	636	688	740	792	844	896	948
				WATTS	117	140	165	191	217	245	274	303	334	365
			Y2	CFM	1566 [739]	1575 [743]	1583 [747]	1590 [750]	1596 [753]	1602 [756]	1607 [758]	1611 [760]	1614 [762]	1616 [763]
				RPM	583	625	668	711	753	796	839	881	924	967
				WATTS	216	250	285	321	356	393	429	467	504	543
RBHM26 5 ton -26	6 (Max.)	208	Y1	CFM	1276 [602]	1278 [603]	1276 [602]	1272 [600]	1264 [597]	1252 [591]	1238 [584]	1220 [576]	1198 [565]	1174 [554]
				RPM	543	598	652	706	761	815	869	924	978	1032
				WATTS	144	173	203	233	265	298	331	366	402	439
			Y2	CFM	1707 [806]	1706 [805]	1704 [804]	1699 [802]	1693 [799]	1685 [795]	1674 [790]	1662 [784]	1648 [778]	1632 [770]
				RPM	659	701	744	786	829	871	914	957	999	1042
				WATTS	303	339	376	414	451	488	526	564	602	640
		230	Y1	CFM	1289 [608]	1288 [608]	1284 [606]	1277 [603]	1268 [598]	1255 [592]	1240 [585]	1223 [577]	1202 [567]	1179 [556]
				RPM	540	595	649	704	758	813	867	922	976	1031
				WATTS	161	186	212	241	271	303	337	372	409	448
			Y2	CFM	1707 [806]	1706 [805]	1704 [804]	1700 [802]	1695 [800]	1689 [797]	1682 [794]	1674 [790]	1664 [785]	1653 [780]
				RPM	669	710	751	793	834	876	917	959	1000	1042
				WATTS	311	350	389	426	464	501	537	573	608	643
	None	208	Y1	CFM	1287 [607]	1285 [606]	1282 [605]	1279 [604]	1276 [602]	1273 [601]	1269 [599]	1266 [597]	1262 [596]	1258 [594]
				RPM	496	547	597	648	699	750	801	851	902	953
				WATTS	130	152	176	202	229	258	289	321	356	391
			Y2	CFM	1692 [800]	1695 [800]	1697 [801]	1699 [802]	1699 [802]	1698 [801]	1696 [800]	1693 [799]	1689 [797]	1683 [794]
				RPM	630	668	705	742	780	817	854	892	929	966
				WATTS	288	316	346	375	406	437	469	502	536	570
		230	Y1	CFM	1294 [611]	1291 [609]	1288 [608]	1285 [606]	1281 [605]	1278 [603]	1274 [601]	1270 [599]	1266 [597]	1261 [595]
				RPM	505	555	605	654	704	754	804	854	903	953
				WATTS	133	158	184	211	239	267	296	325	356	387
			Y2	CFM	1699 [802]	1703 [804]	1705 [805]	1706 [805]	1706 [805]	1705 [805]	1703 [804]	1700 [802]	1696 [800]	1691 [798]
				RPM	615	655	695	735	775	815	855	895	935	976
				WATTS	287	318	349	380	412	443	474	505	536	567

IMPORTANT: Observe airflow operating limits. Do not operate above 1.0 in. W.C. system external static.

[] Designates Metric Conversions

Blower Motor Electrical Data

Model Size/Elec. Designation	HP [W]	Voltage	Phase	Hertz	RPM	Circuit Amps.	Minimum Circuit Ampacity	Maximum Circuit Protector
17J	1/3 [249]	208/230	1	60	300-1100	3.0/2.8	4/4	15
24J	1/2 [373]	208/230	1	60	300-1100	5.0/4.3	7/6	15
25J	3/4 [559]	208/230	1	60	300-1100	6.6/5.9	9/8	15
26J	1 [746]	208/230	1	60	300-1100	9.4/9.1	12/12	15

Electric Heat Electrical Data

Model Elec./KW Designation	PH/HZ	Type Supply Circuit Single Circuit Multiple Circuit*	Heater No./KW @ 240V	Heater KW 208/240V	Circuit Amps.	Minimum Circuit Ampacity	Maximum Circuit Protector
17J06	1/60	Single Circuit	2/2.5	3.7/4.9	20.6/23.2	26/29	30/30
17J07	1/60	Single Circuit	2/3.5	5.3/7.0	28.2/32.0	36/40	40/40
17J11	1/60	Single Circuit	3/3.5	7.9/10.5	40.8/46.6	51/59	60/60
24J07	1/60	Single Circuit	2/3.5	5.3/7.0	30.2/33.5	38/42	40/45
24J11	1/60	Single Circuit	3/3.5	7.9/10.5	42.8/48.1	54/61	60/70
24J14	1/60	Single Circuit	4/3.5	10.5/14.0	55.4/62.7	70/79	70/80
		Multiple Ckt. 1	2/3.5	5.3/7.0	30.2/33.5	38/42	40/45
		Multiple Ckt. 2	2/3.5	5.3/7.0	25.2/29.2	32/37	35/40
25J11	1/60	Single Circuit	3/3.5	7.9/10.5	44.4/49.7	56/63	60/70
25J14	1/60	Single Circuit	4/3.5	10.5/14.0	57.0/64.3	72/81	80/90
		Multiple Ckt. 1	2/3.5	5.3/7.0	31.8/35.1	40/44	40/45
		Multiple Ckt. 2	2/3.5	5.3/7.0	25.2/29.2	32/37	35/40
25J18	1/60	Single Circuit	5/3.5	13.1/17.5	69.6/78.9	87/99	90/100
		Multiple Ckt. 1	2/3.5	5.3/7.0	31.8/35.1	40/44	40/45
		Multiple Ckt. 2	3/3.5	7.9/10.5	37.8/43.8	48/55	50/60
26J11	1/60	Single Circuit	3/3.5	7.9/10.5	47.2/52.9	59/67	60/70
26J14	1/60	Single Circuit	4/3.5	10.5/14.0	59.8/67.5	75/85	80/90
		Multiple Ckt. 1	2/3.5	5.3/7.0	34.6/38.3	44/48	45/50
		Multiple Ckt. 2	2/3.5	5.3/7.0	25.2/29.2	32/37	35/40
26J18	1/60	Single Circuit	5/3.5	13.1/17.5	72.4/82.1	91/103	100/110
		Multiple Ckt. 1	2/3.5	5.3/7.0	34.6/38.3	44/48	45/50
		Multiple Ckt. 2	3/3.5	7.9/10.5	37.8/43.8	48/55	50/60
26J21	1/60	Single Circuit	6/3.5	15.8/21.0	85.0/96.7	107/121	110/125
		Multiple Ckt. 1	3/3.5	7.9/10.5	47.2/52.9	59/67	60/70
		Multiple Ckt. 2	3/3.5	7.9/10.5	37.8/43.8	48/55	50/60

*Unit shipped from factory wired for single supply circuit. Unit may be field converted to multiple supply circuit.

Electric Heat Backup CFM Tube 1				
Model	PH	Maximum KW	HP	CFM
RBHM-17	1/60	11	1/3	500
RBHM-24	1/60	14	1/2	1000
RBHM-25	1/60	18	3/4	1400
RBHM-26	1/60	21	1	1600

[] Designates Metric Conversions

Copper Wire Size—AWG. (3% Voltage Drop)

S U P P L Y	L E N G T H	200 [61]	12	10	8	8	8	6	6	6	4	4	3	3	2	2	1	0	00
		150 [46]	12	10	10	10	8	8	6	6	6	4	4	3	3	2	1	0	00
		100 [30]	14	12	10	10	8	8	8	6	6	4	4	3	3	2	1	0	00
		50 [15]	14	12	10	10	8	8	8	6	6	4	4	3	3	2	1	0	00
W I R E	F E E T	[m]	15	20	25	30	35	40	45	50	60	70	80	90	100	110	125	150	175
		<p>SUPPLY CIRCUIT AMPACITY</p> <p>NOTE: Wire based on copper conductors 75°C minimum rating. For more than 3 conductors in a raceway or cable, see N.E.C. for derating the ampacity of each conductor.</p>																	

Combustible Floor Base for Downflow Installations

ACCESSORIES—KITS—PARTS

- Filter Bases

Model Cabinet Size	Filter Size In. [mm]	Filter Width	Part Number
-17	16 x 20 [406 x 508]	1" or 2"	54-1620-E3
-24	25 x 20 [635 x 508]	1" or 2"	54-2025-E3
-25	25 x 20 [635 x 508]	1" or 2"	54-2025-E3
-26	25 x 20 [635 x 508]	1" or 2"	54-2025-E3

[] Designates Metric Conversions

Before proceeding with installation, refer to installation instructions packaged with each model, as well as complying with all Federal, State, Provincial, and Local codes, regulations, and practices.

**Ruud Heating,
Cooling and
Water Heating**

P.O. Box 17010, Fort Smith, AR 72917



"In keeping with its policy of continuous progress and product improvement, Ruud reserves the right to make changes without notice."