

PRINTING INSTRUCTIONS: MAKE EXACTLY 8 X 10. WHITE WITH BLACK LETTERING (WATERPROOF)	REVISIONS	-	CORRECTED BORDER, ORIGINAL RELEASE NO A-1093S009 WAS A-1073S009.	TEW	A-1093S018 02-14-18	NO REVISION TO DESIGN, MATERIAL, TOOLING, OR PROCESS IS ACCEPTABLE WITHOUT PRIOR APPROVAL FROM RHEEM THROUGH AN AUTHORIZED CHANGE NOTICE. A REVISED ENGINEERING SPECIFICATION AND A RESAMPLING OF PARTS. THE SUPPLIER IS RESPONSIBLE FOR NOTIFYING RHEEM R & D AND PURCHASING DEPARTMENTS IN WRITING OF ANY CHANGES AFFECTING PRODUCT QUALITY, PERFORMANCE, RELIABILITY, PACKAGING, DELIVERY OR WORKMANSHIP. *ANY DOCUMENTS REFERRED TO ON THIS DRAWING ARE INCLUDED IN THE SPECIFICATIONS FOR THIS COMPONENT*.
		01	REVISED WIRES FROM LOW VOLTAGE FIELD CONNECTION, TERMINAL BLOCKS AND COMPRESSOR.	VYM	Y-0546S099 01-14-19	
		02	REVISED WIRE FROM CRANKCASE HEATER 1.	VYM	Y-0655S446 01-23-19	
MATERIAL: PRESSURE SENSITIVE, ADHESIVE BACKED LABEL. (VINYL)						

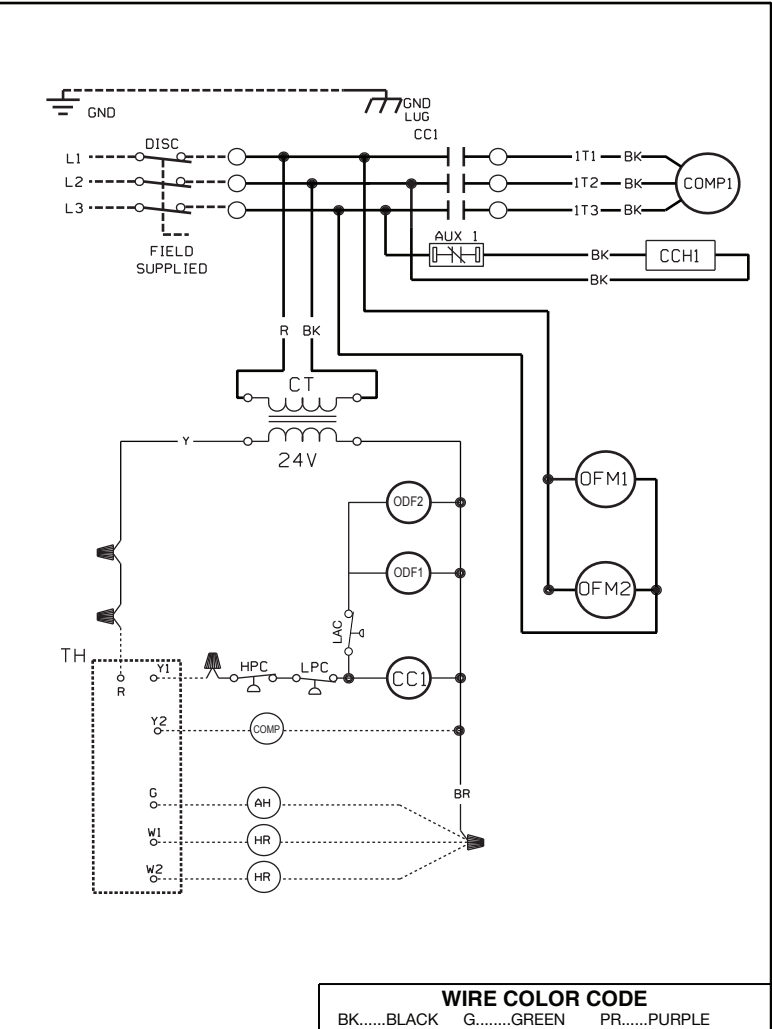
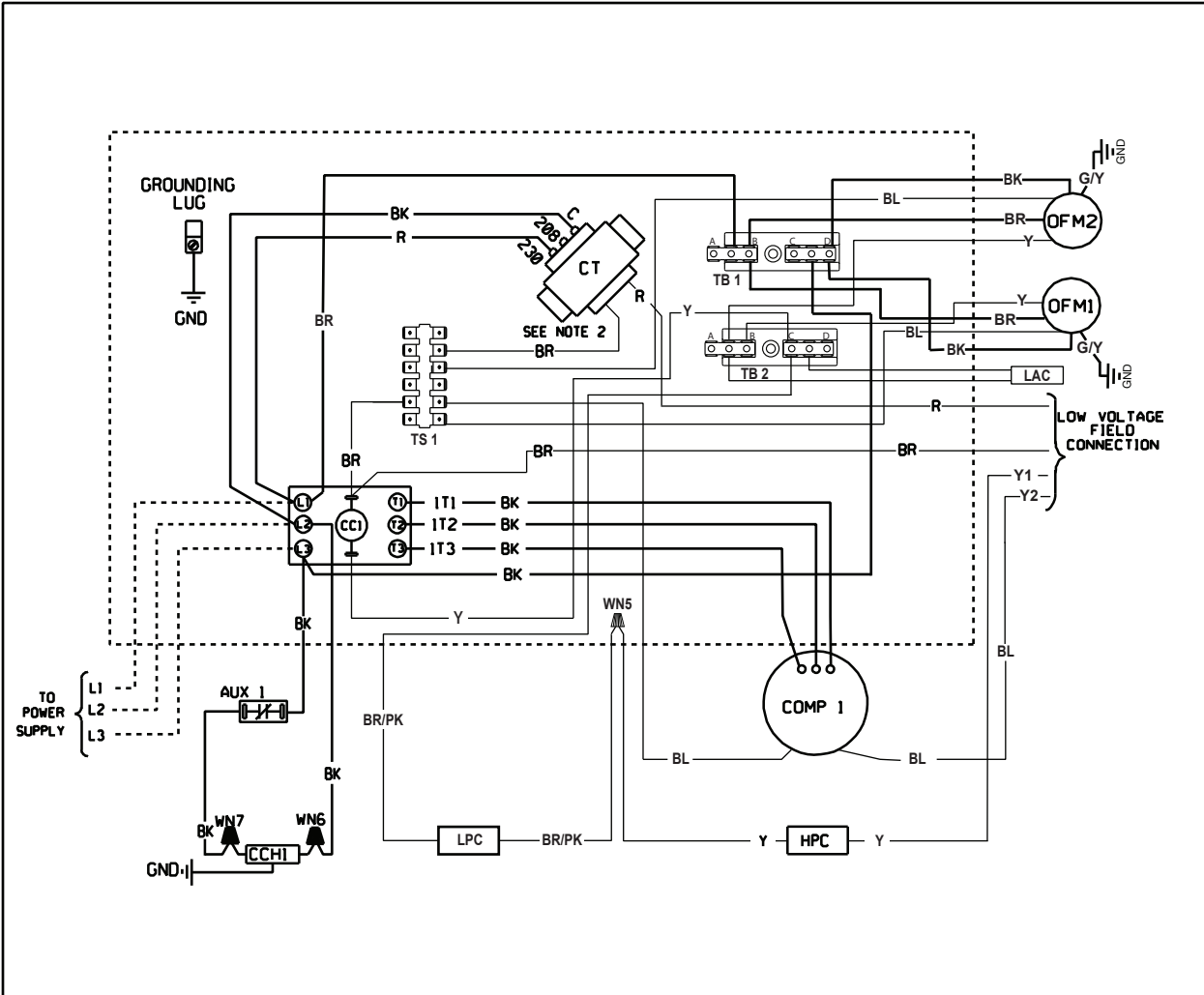

WIRING INFORMATION

LINE VOLTAGE
 -FACTORY STANDARD _____
 -FACTORY OPTION - - - - -
 -FIELD INSTALLED - - - - -

LOW VOLTAGE
 -FACTORY STANDARD _____
 -FIELD INSTALLED - - - - -

REPLACEMENT WIRE
 -MUST BE THE SAME SIZE AND TYPE OF INSULATION AS ORIGINAL (105C. MIN.)

WARNING
 -CABINET MUST BE PERMANENTLY GROUNDED AND CONFORM TO I.E.C., N.E.C., C.E.C., NATIONAL WIRING REGULATIONS, AND LOCAL CODES AS APPLICABLE.

NOTES

- ALL THREE-PHASE MOTORS ARE INTERNALLY PROTECTED AGAINST PRIMARY SINGLE-PHASING CONDITIONS.
- MAIN UNIT TRANSFORMER PRIMARY SHOWN WIRED FOR 230V. OPERATION. FOR OTHER VOLTAGE APPLICATIONS WIRE TO COMMON & APPLICABLE VOLTAGE TAP, 208, 460, 575 . & ETC.

COMPONENT CODES

AUX.	AUXILIARY CONTACTOR	LPC	LOW PRESSURE CONTROL
CB	CIRCUIT BREAKER	OFM	OUTDOOR FAN MOTOR
CC	COMPRESSOR CONTACTOR	RC	RUN CAPACITOR
CCH	CRANKCASE HEATER	R	RELAY
COMP	COMPRESSOR	TB	TERMINAL BLOCK
CT	CONTROL TRANSFORMER	TDC	TIME DELAY CONTROL
GND	GROUND	TS	TERMINAL STRIP
HPC	HIGH PRESSURE CONTROL	▲	WIRE NUT
LAC	LOW AMBIENT CONTROL		

WIRE COLOR CODE

BK.....BLACK	G.....GREEN	PR.....PURPLE
BR.....BROWN	GY.....GRAY	R.....RED
BL.....BLUE	O.....ORANGE	W.....WHITE
		Y.....YELLOW

ELECTRICAL WIRING DIAGRAM

CONDENSING UNIT
 10 TON

208-230, 380, 460 3PH 60Hz &
 200-220, 380-415 3PH 50Hz &
 - 575 3PH 60Hz

APPROVED:	CHECKED:	ORIGINAL RELEASE NO.:
MODELED BY: JHB	DATE: 11/14/2017	A-1093S009
PART NO.:	90-42663-13	REV: 02