



RAWL

Parts List
10-April-2018



*This parts list is current as of the above revision date.
See <http://www.rheempartslists.net/92-42800-RAWL.pdf> for the current revision.*

Condensing Units - Commercial

Table of Contents

Model Explanation.....	Page 3
------------------------	--------

Parts Numbers

Panels 078-090 - Miscellaneous (Granite-Steel Gray).....	Page 4
Panels 079-091 - Miscellaneous (Granite-Steel Gray).....	Page 5
Panels 121 - Miscellaneous (Granite-Steel Gray).....	Page 6
Panels 120-240 - Miscellaneous (Granite-Steel Gray).....	Page 7
Panels 078-240 - Miscellaneous (Neutra Green).....	Page 8
Electrical-Fan Group 121.....	Page 9
Electrical Group 078-240.....	Page 10
Fan Group 078-240.....	Page 11
Electrical-Fan Group 079-091.....	Page 12
Coil Parts 079-091.....	Page 13
Coil Parts 078-240.....	Page 14
Compressor Group 079-091.....	Page 15
Compressor Group 078-125.....	Page 16
Compressor Group 150-240.....	Page 17
Accessories 079-091.....	Page 18
Accessories 078-240.....	Page 19

Drawings/Photographs

Exploded View 078-090 Old Cabinet.....	Page 20
Exploded View 078-090 New Cabinet.....	Page 21
Exploded View 079-091.....	Page 22
Exploded View 120-150.....	Page 23
Exploded View 180-240.....	Page 24
Control Box 078-090.....	Page 25
Control Box 079-091.....	Page 25
Control Box 120-240.....	Page 26
Compressor Assembly 120-240.....	Page 27
Valve Mounting, Compressor 079-091.....	Page 28
Coils - Compressor 121.....	Page 29
Control Box 121.....	Page 30

Notes/Disclaimer.....	Page 31
-----------------------	---------

MODEL NUMBER EXPLANATION

R	A	W	L	-	1	2	0	C	A	Z
1	2	3	4		5			6	7	8

- 1 TRADEBRAND IDENTIFICATION**
- 2 TYPE**
A = Condensing Unit
- 3 DESIGNATION**
W = Standard Efficiency Commercial
- 4 DESIGN SERIES**
- 5 COOLING CAPACITY**

078 = 6.5 Tons	150 = 12.5 Tons
079 = 6.5 Tons	180 = 15 Tons
090 = 7.5 Tons	240 = 20 Tons
091 = 7.5 Tons	
120 = 10 Tons	
121 = 10 Tons (Two Speed Compressor)	
125 = 10 Tons (Two Stage)	
- 6 ELECTRICAL DESIGNATION**
C = 208-230/3/60
D = 460/3/60
Y = 575/3/60
- 7 DESIGN VARIATION**
A = Standard
- 8 COMPRESSOR TYPE**
Z = Scroll Compressor

SERIAL NUMBER EXPLANATION (Units Produced before Nov. 2013)

7	7	5	3	F	4	6	0	8	9	9	9	9
1		2			3		4		5			

- 1 COMPRESSOR IDENTIFICATION NUMBER**
- 2 PRODUCTION LOCATION**
F = Fort Smith, AR
- 3 WEEK OF PRODUCTION**
- 4 YEAR OF PRODUCTION**
- 5 PRODUCTION NUMBER**

SERIAL NUMBER EXPLANATION (Units Produced after Nov. 2013)

F	0	8	1	3	9	9	9	9
(1)	(2)		(3)		(4)			

- (1) PLANT CODE**
F = Fort Smith, AR
- (2) WEEK OF PRODUCTION**
- (3) YEAR OF PRODUCTION**
- (4) PRODUCTION NUMBER**

Note: For Compressor Identification Number, see Compressor Code on Rating Plate

No.	Notes	MODEL COOLING CAPACITY	RAWL 078	RAWL 090		
PANELS, MISCELLANEOUS PARTS - Single Wrap Cabinet (Granite Steel Gray - After F4411)						
1		Base Pan	AE-58426-83	AE-58426-83		
3		Button Plug	45-22980-07	45-22980-07		
4		Cabinet - Single Wrap	AS-100609-07H	AS-100609-07H		
5		Top Panel	AS-100618-05H	AS-100618-05H		
8		Grille	95-100906-05	95-100906-05		
9		Control Box	AE-100633-01	AE-100633-01		
10		Access Panel	AS-100617-07H	AS-100617-07H		
13a		Service Valve (Liquid)			See Coil Group	
13b		Service Valve (Suction)			See Coil Group	
17		Adapter Plate	AE-54609-02	AE-54609-02		
		Mounting Bracket - Service Valve	AE-102833-02	AE-102833-02		
		Valve Mounting Bracket	AE-56389-02	AE-56389-02		
		Touch-up Paint - Granite/Steel Gray (Aerosol)	PD523018	PD523018		
		Touch-up Paint - Granite/Steel Gray (Paint Pens)	PD523019	PD523019		

No.	Notes	MODEL COOLING CAPACITY	RAWL 078	RAWL 090		
PANELS, MISCELLANEOUS PARTS - Five Piece Cabinet (Granite Steel Gray - After F4411)						
1		Base Pan	AE-58426-83HT	AE-58426-83HT		
3		Button Plug	45-22980-07	45-22980-07		
4a		Louver Cabinet Panel - Rear	10-105335-02HT	10-105335-02HT		
4b		Louver Cabinet Panel - Side Rear	10-105334-06HT	10-105334-06HT		
4c		Louver Cabinet Panel - Right Front	10-105334-05HT	10-105334-05HT		
4d		Louver Cabinet Panel - Left Front	10-105334-04HT	10-105334-04HT		
4e		Louver Cabinet Panel - Side Rear	10-105334-06HT	10-105334-06HT		
5		Top Panel	AE-100618-05HT	AE-100618-05HT		
8		Grille	95-100906-05	95-100906-05		
9		Control Box	AE-100633-01	AE-100633-01		
10		Access Panel	AE-100617-07HT	AE-100617-07HT		
13a		Service Valve (Liquid)			See Coil Group	
13b		Service Valve (Suction)			See Coil Group	
17		Adapter Plate	AE-54609-02	AE-54609-02		
		Mounting Bracket - Service Valve	AE-102833-02	AE-102833-02		
		Valve Mounting Bracket	AE-56389-02	AE-56389-02		
		Touch-up Paint - Granite/Steel Gray (Aerosol)	PD523018	PD523018		
		Touch-up Paint - Granite/Steel Gray (Paint Pens)	PD523019	PD523019		

No.	Notes	MODEL COOLING CAPACITY VARIATION	RAWL 079 CAZ	RAWL 079 DAZ	RAWL 091 CAZ	RAWL 091 DAZ
SHEET METAL PARTS, MISCELLANEOUS						
1		Front Panel	AE-104456-46	AE-104456-46	AE-104456-49	AE-104456-49
2		Left Panel (Badge Panel)	AE-104456-57	AE-104456-57	AE-104456-58	AE-104456-58
3		Back Panel	AE-104456-47	AE-104456-47	AE-104456-50	AE-104456-50
4		Right Panel	AE-104456-46	AE-104456-46	AE-104456-49	AE-104456-49
5		Base Pan	68-104457-03	68-104457-03	68-104457-03	68-104457-03
6		Control Box	AE-104461-05	AE-104461-05	AE-104461-05	AE-104461-05
7		Control Box Cover	AS-104462-01H	AS-104462-01H	AS-104462-01H	AS-104462-01H
8		Control Box Bracket	AS-104460-06H	AS-104460-06H	AS-104460-11H	AS-104460-11H
9		Service Door	AS-104525-01H	AS-104525-01H	AS-104525-01H	AS-104525-01H
10		Center Post (2)	AS-104459-11H	AS-104459-11H	AS-104459-13H	AS-104459-13H
12		Corner Post - Louvered	AS-104469-06H (3)	AS-104469-06H (3)	AS-104469-07H (3)	AS-104469-07H (3)
13		Top Panel	AS-104458-03H	AS-104458-03H	AS-104458-03H	AS-104458-03H
14		Venturi	68-104464-07	68-104464-07	68-104464-09	68-104464-09
15		Grille	95-104620-04	95-104620-04	95-104620-04	95-104620-04
		Center Cap - Blank (for Grille)	91-105471-01	91-105471-01	91-105471-01	91-105471-01
		Service Valve - Suction	See Coil Group			
		Service Valve - Liquid	See Coil Group			
		Touch-up Paint - Granite/Steel Gray (Aerosol)	PD523018	PD523018	PD523018	PD523018
		Touch-up Paint - Granite/Steel Gray (Paint Pens)	PD523019	PD523019	PD523019	PD523019

No.	Notes	MODEL COOLING CAPACITY			RAWL 121		
PANELS, MISCELLANEOUS PARTS (Granite Steel Gray)							
1		Base Rail - End (2)			AE-90925-01		
2		Base Rail - Side (2)			AE-90925-04		
3		Middle Support Base Rail			AE-90925-05		
4		Base Pan			AE-90929-04HT		
5		Wire Grille			95-42507-01		
6		Access Panel - Front			AE-90937-01HT		
7		Access Panel - Rear			AE-90938-01HT		
8		Corner Post (4)			AE-90930-01HT		
9		Louvered Panel (4)			AE-90944-03HT		
10		Center Post			AE-105378-01HT		
11		Connection Panel			AE-90936-04HT		
12		Top Panel			AS-90942-08HT		
13		Venturi Ring			AE-90632-01HT		
14		Control Box Cover			AE-90935-01HT		
15		Control Box			AS-90933-02		
15a		Bushing - Strain Relief			45-17055-11		
15b		Bushing - Strain Relief			45-17055-07		
15c		Bushing - Strain Relief			45-17055-01		
16		Control Box Mounting Bracket - Side (2)			AE-90934-01		
17		Control Box Mounting Bracket - Top			AE-90934-02		
18		Control Box Mounting Bracket - Bottom			AE-90934-03HT		
19		Guard for High Pressure Control			AE-76160-01HT		
20		Hole Plug			45-40356-10		
		Mounting Bracket - Service Valve			AE-102833-02		
		Switch Mounting Bracket			AE-90946-01		
		Touch-up Paint - Granite/Steel Gray (Aerosol)			PD523018		
		Touch-up Paint - Granite/Steel Gray (Paint Pens)			PD523019		

No.	Notes	MODEL COOLING CAPACITY	RAWL 120	RAWL 125	RAWL 150	RAWL 180	RAWL 240
PANELS, MISCELLANEOUS PARTS (Granite Steel Gray - After F4411)							
1		Base Rail - End	AE-90925-01	AE-90925-01	AE-90925-01	AE-90925-01	AE-90925-01
2		Base Rail - Side	AE-90925-03	AE-90925-03	AE-90925-04	AE-90925-02	AE-90925-02
3		Middle Support Base Rail	AE-90925-05	AE-90925-05	AE-90925-05	AE-90925-05	AE-90925-05
4		Base Pan	AS-90929-02H	AS-90929-02H	AS-90929-04H	AS-90929-05H	AS-90929-01H
5		Wire Grille	95-42507-01	95-42507-01	95-42507-01	95-42507-01	95-42507-01
6		Access Panel - Front	AS-90937-01H	AS-90937-01H	AS-90937-01H	AS-90937-01H	AS-90937-01H
7		Access Panel - Rear	AS-90938-01H	AS-90938-01H	AS-90938-01H	AS-90938-01H	AS-90938-01H
8		Corner Post (4)	AS-90930-01H	AS-90930-01H	AS-90930-01H	AS-90930-01H	AS-90930-01H
9		Louvered Panel (4)	AS-90944-08H	AS-90944-08H	AS-90944-03H	AS-90944-01H	AS-90944-01H
10		Center Post	AS-90931-01H	AS-90931-01H	AS-90931-01H	AS-90931-01H	AS-90931-01H
11		Connection Panel	AS-90936-04H	AS-90936-04H	AS-90936-04H	AS-90936-03H	AS-90936-03H
12		Top Panel	AS-90942-02H	AS-90942-02H	AS-90942-04H	AS-90942-01H	AS-90942-01H
13		Venturi Ring	AS-90632-01H	AS-90632-01H	AS-90632-01H	AS-90632-01H	AS-90632-01H
14		Control Box Cover	AS-90935-01H	AS-90935-01H	AS-90935-01H	AS-90935-01H	AS-90935-01H
15		Control Box	AS-90933-02	AS-90933-02	AS-90933-02	AS-90933-02	AS-90933-02
16		Control Box Mounting Bracket - Side	AE-90934-01	AE-90934-01	AE-90934-01	AE-90934-01	AE-90934-01
17		Control Box Mounting Bracket - Top	AE-90934-02	AE-90934-02	AE-90934-02	AE-90934-02	AE-90934-02
18		Control Box Mounting Bracket - Bottom	AS-90934-03H	AS-90934-03H	AS-90934-03H	AS-90934-03H	AS-90934-03H
19		Guard for High Pressure Control	AS-76160-01H	AS-76160-01H	AS-76160-01H	AS-76160-01H	AS-76160-01H
20		Hole Plug	45-40356-10	45-40356-10	45-40356-10	45-40356-10	45-40356-10
		Mounting Bracket - Service Valve	AE-102833-02	AE-102833-02	AE-102833-02	AE-102833-02	AE-102833-02
		Switch Mounting Bracket	AE-90946-01	AE-90946-01	AE-90946-01	AE-90946-01	AE-90946-01
		Touch-up Paint - Granite/Steel Gray (Aerosol)	PD523018	PD523018	PD523018	PD523018	PD523018
		Touch-up Paint - Granite/Steel Gray (Paint Pens)	PD523019	PD523019	PD523019	PD523019	PD523019

No.	Notes	MODEL COOLING CAPACITY	RAWL 078	RAWL 090			
PANELS, MISCELLANEOUS PARTS (Neutra Green - Before F4411)							
1		Base Pan	AE-58426-03	AE-58426-03			
3		Button Plug	45-22980-07	45-22980-07			
4		Cabinet	AE-100609-07	AE-100609-07			
5		Top Panel	AE-100618-05	AE-100618-05			
8		Grille	95-100906-05	95-100906-05			
9		Control Box	AE-100633-01	AE-100633-01			
10		Access Panel	AE-100617-07	AE-100617-07			
13a		Service Valve (Liquid)			See Coil Group		
13b		Service Valve (Suction)			See Coil Group		
17		Adapter Plate	AE-54609-02	AE-54609-02			
		Mounting Bracket - Service Valve (Before F3310)	AE-102833-01	AE-102833-01			
		Mounting Bracket - Service Valve (After F3310)	AE-102833-02	AE-102833-02			
		Valve Mounting Bracket	AE-56389-02	AE-56389-02			
		Touch-up Paint - Rheem Green (Aerosol)	52-18662-48	52-18662-48			
		Touch-up Paint - Rheem Green (Paint Pens)	523010	523010			

No.	Notes	MODEL COOLING CAPACITY	RAWL 120	RAWL 125	RAWL 150	RAWL 180	RAWL 240
PANELS, MISCELLANEOUS PARTS (Neutra Green - Before F4411)							
1		Base Rail - End	AE-90925-01	AE-90925-01	AE-90925-01	AE-90925-01	AE-90925-01
2		Base Rail - Side	AE-90925-03	AE-90925-03	AE-90925-04	AE-90925-02	AE-90925-02
3		Middle Support Base Rail	AE-90925-05	AE-90925-05	AE-90925-05	AE-90925-05	AE-90925-05
4		Base Pan	AS-90929-02	AS-90929-02	AS-90929-04	AS-90929-05A	AS-90929-01
5		Wire Grille	95-42507-01	95-42507-01	95-42507-01	95-42507-01	95-42507-01
6		Access Panel - Front	AS-90937-01A	AS-90937-01A	AS-90937-01A	AS-90937-01A	AS-90937-01A
7		Access Panel - Rear	AS-90938-01A	AS-90938-01A	AS-90938-01A	AS-90938-01A	AS-90938-01A
8		Corner Post (4)	AS-90930-01A	AS-90930-01A	AS-90930-01A	AS-90930-01A	AS-90930-01A
9		Louvered Panel (4)	AS-90944-08A	AS-90944-08A	AS-90944-03A	AS-90944-01A	AS-90944-01A
10		Center Post	AS-90931-01A	AS-90931-01A	AS-90931-01A	AS-90931-01A	AS-90931-01A
11		Connection Panel - Before F3310	AS-90936-02A	AS-90936-02A	AS-90936-02A	AS-90936-01A	AS-90936-01A
11		Connection Panel - After F3310	AS-90936-04A	AS-90936-04A	AS-90936-04A	AS-90936-03A	AS-90936-03A
12		Top Panel	AS-90942-02	AS-90942-02	AS-90942-04	AS-90942-01	AS-90942-01
13		Venturi Ring	AS-90632-01A	AS-90632-01A	AS-90632-01A	AS-90632-01A	AS-90632-01A
14		Control Box Cover	AS-90935-01A	AS-90935-01A	AS-90935-01A	AS-90935-01A	AS-90935-01A
15		Control Box	AS-90933-02	AS-90933-02	AS-90933-02	AS-90933-02	AS-90933-02
16		Control Box Mounting Bracket - Side	AE-90934-01	AE-90934-01	AE-90934-01	AE-90934-01	AE-90934-01
17		Control Box Mounting Bracket - Top	AE-90934-02	AE-90934-02	AE-90934-02	AE-90934-02	AE-90934-02
18		Control Box Mounting Bracket - Bottom	AS-90934-03A	AS-90934-03A	AS-90934-03A	AS-90934-03A	AS-90934-03A
19		Guard for High Pressure Control;	AS-76160-01A	AS-76160-01A	AS-76160-01A	AS-76160-01A	AS-76160-01A
20		Hole Plug	45-40356-10	45-40356-10	45-40356-10	45-40356-10	45-40356-10
		Mounting Bracket - Service Valve (Before F3310)	AE-102833-01	AE-102833-01	AE-102833-01	AE-102833-01	AE-102833-01
		Mounting Bracket - Service Valve (After F3310)	AE-102833-02	AE-102833-02	AE-102833-02	AE-102833-02	AE-102833-02
		Switch Mounting Bracket	AE-90946-01	AE-90946-01	AE-90946-01	AE-90946-01	AE-90946-01
		Touch-up Paint - Rheem Green (Aerosol)	52-18662-48	52-18662-48	52-18662-48	52-18662-48	52-18662-48
		Touch-up Paint - Rheem Green (Paint Pens)	523010	523010	523010	523010	523010

No.	Notes	MODEL COOLING CAPACITY ELECTRICAL DESIGNATION	RAWL 121 C	RAWL 121 D		
ELECTRICAL GROUP						
32	Stk	Contactora	42-102664-19	42-102664-19		
33		Terminal Block	45-106539-01 (2)	45-106539-01 (2)		
33a		Terminal Strip	45-23591-01	45-23591-01		
34		Grounding Lug	45-19000-02	45-19000-02		
35	Stk	Transformer	46-42515-01	46-42515-02		
	Stk	Time Delay Relay	42-22906-01	42-22906-01		
37		High Pressure Control			See Coil Group	
38		Low Pressure Control			See Coil Group	
39		Low Ambient Control			See Coil Group	
		Wiring Harness (from contactor to compressor)	45-42522-63	45-42522-63		
		Wiring Harness (compressor - low voltage)	45-101723-02	45-101723-02		
FAN GROUP						
24	Stk	Fan Motor (ECM)	51-106920-01 (2)	51-106920-02 (2)		
25	Stk	Capacitor - Fan Motor	N/A	N/A		
26	Stk	Fan Blade	70-42572-01 (2)	70-42572-01 (2)		
27		Cap/Rain Shield	N/A	N/A		
28		Motor Mount - Outdoor Fan	70-42504-01 (2)	70-42504-01 (2)		

No.	Notes	MODEL COOLING CAPACITY ELECTRICAL DESIGNATION	RAWL 078 C	RAWL 090 C	RAWL 078 D	RAWL 090 D	RAWL 078 Y	RAWL 090 Y
ELECTRIC GROUP								
14	Stk	Control Transformer	46-41930-01	46-41930-01	46-41930-01	46-41930-01	46-22384-01	46-22384-01
15	Stk	Contacto	42-22464-01	42-22464-02	42-22464-01	42-22464-01	42-22464-01	42-22464-01
18		Low Ambient Control	See Coil Group					
		Control Bracket - Low Ambient Control	AE-90946-01	AE-90946-01	AE-90946-01	AE-90946-01	AE-90946-01	AE-90946-01

No.	Notes	MODEL COOLING CAPACITY ELECTRICAL DESIGNATION	RAWL 120 C	RAWL 125 C	RAWL 120 D	RAWL 125 D	RAWL 120 Y	RAWL 125 Y
ELECTRICAL GROUP								
32	Stk	Contacto	42-42667-03 (1)	42-42667-02 (2)	42-42667-03 (1)	42-42667-02 (2)	42-42667-03 (1)	42-42667-02 (2)
33		Terminal Block	N/A	45-41669-01	N/A	45-41669-01	N/A	45-41669-01
34	Stk	Relay	N/A	42-19736-07	N/A	42-19736-07	N/A	42-19736-07
35	Stk	Transformer	46-42515-01	46-42515-01	46-42505-02	46-42505-02	46-42505-02	46-42505-02
36	Stk	Time Delay Relay	N/A	42-22906-01	N/A	42-22906-01	N/A	42-22906-01
37		High Pressure Control	See Coil Group					
38		Low Pressure Control	See Coil Group					
39		Low Ambient Control	See Coil Group					
		Wiring Harness - Outdoor Fan Motors	45-42522-60	45-42522-60	45-42522-60	45-42522-60	45-42522-60	45-42522-60
		Wiring Harness - Compressor	45-42522-63	45-42522-61	45-42522-63	45-42522-61	45-42522-63	45-42522-61

No.	Notes	MODEL COOLING CAPACITY ELECTRICAL DESIGNATION	RAWL 150 C	RAWL 180 C	RAWL 240 C	RAWL 150 D	RAWL 180 D	RAWL 240 D
32	Stk	Contacto	42-42667-03 (2)	42-42667-03 (2)	42-42667-01 (1)	42-42667-03 (2)	42-42667-03 (2)	42-42667-03 (2)
33		Terminal Block	45-41669-01	45-41669-01	45-41669-01	45-41669-01	45-41669-01	45-41669-01
34	Stk	Relay	42-19736-07	42-19736-07	42-19736-07	42-19736-07	42-19736-07	42-19736-07
35	Stk	Transformer	46-42515-01	46-42515-01	46-42515-04	46-42505-02	46-42515-02	46-42515-05
36	Stk	Time Delay Relay	42-22906-01	42-22906-01	42-22906-01	42-22906-01	42-22906-01	42-22906-01
37		High Pressure Control	See Coil Group					
38		Low Pressure Control	See Coil Group					
39		Low Ambient Control	See Coil Group					
		Wiring Harness - Outdoor Fan Motors	45-42522-60	45-42522-56	45-42522-56	45-42522-60	45-42522-56	45-42522-56
		Wiring Harness - Compressor	45-42522-61	45-42522-59	45-42522-94	45-42522-61	45-42522-59	45-42522-94

No.	Notes	MODEL COOLING CAPACITY ELECTRICAL DESIGNATION	RAWL 150 Y	RAWL 180 Y	RAWL 240 Y			
32	Stk	Contacto	42-42667-03 (2)	42-42667-03 (2)	42-42667-03 (2)			
33		Terminal Block	45-41669-01	45-41669-01	45-41669-01			
34	Stk	Relay	42-19736-07	42-19736-07	42-19736-07			
35	Stk	Transformer	46-42505-02	46-42515-02	46-42515-05			
36	Stk	Time Delay Relay	42-22906-01	42-22906-01	42-22906-01			
37		High Pressure Control	See Coil Group					
38		Low Pressure Control	See Coil Group					
39		Low Ambient Control	See Coil Group					
		Wiring Harness - Outdoor Fan Motors	45-42522-60	45-42522-56	45-42522-56			
		Wiring Harness - Compressor	45-42522-61	45-42522-59	45-42522-94			

No.	Notes	MODEL COOLING CAPACITY ELECTRICAL DESIGNATION	RAWL 078 C	RAWL 090 C	RAWL 078 D	RAWL 090 D	RAWL 078 Y	RAWL 090 Y
FAN GROUP								
6	Stk	Fan Blade	70-42484-01	70-42484-01	70-42484-01	70-42484-01	70-42484-01	70-42484-01
7	Stk	Fan Motor	51-100998-13	51-100998-13	51-100998-12	51-100998-12	51-100998-14	51-100998-14
16	Stk	Capacitor - Fan Motor	43-100496-12	43-100496-12	43-100496-12	43-100496-12	43-100496-11	43-100496-11

No.	Notes	MODEL COOLING CAPACITY ELECTRICAL DESIGNATION	RAWL 120 C	RAWL 125 C	RAWL 120 D	RAWL 125 D	RAWL 120 Y	RAWL 125 Y
FAN GROUP								
24	Stk	Fan Motor	51-42534-01 (2)	51-42534-01 (2)	51-42534-02 (2)	51-42534-02 (2)	51-42534-03 (2)	51-42534-03 (2)
25	Stk	Capacitor - Fan Motor	43-100496-12 (2)	43-100496-12 (2)	43-100496-12 (2)	43-100496-12 (2)	43-100496-12 (2)	43-100496-12 (2)
26	Stk	Fan Blade	70-42572-01 (2)	70-42572-01 (2)	70-42572-01 (2)	70-42572-01 (2)	70-42572-01 (2)	70-42572-01 (2)
27		Cap/Rain Shield	56-17070-01 (2)	56-17070-01 (2)	56-17070-01 (2)	56-17070-01 (2)	56-17070-01 (2)	56-17070-01 (2)
28		Motor Mount - Outdoor Fan	70-42504-01 (2)	70-42504-01 (2)	70-42504-01 (2)	70-42504-01 (2)	70-42504-01 (2)	70-42504-01 (2)

No.	Notes	MODEL COOLING CAPACITY ELECTRICAL DESIGNATION	RAWL 150 C	RAWL 180 C	RAWL 240 C	RAWL 150 D	RAWL 180 D	RAWL 240 D
FAN GROUP								
24	Stk	Fan Motor	51-42534-01 (2)	51-42534-01 (3)	51-42534-09 (3)	51-42534-02 (2)	51-42534-02 (3)	51-42534-14 (3)
		Motor Wiring Harness	45-42522-60	45-42522-56	45-42522-56	45-42522-60	45-42522-56	45-42522-56
25	Stk	Capacitor - Fan Motor	43-100496-12 (2)	43-100496-12 (3)	43-100496-41 (3)	43-100496-12 (2)	43-100496-12 (3)	43-100496-12 (3)
26	Stk	Fan Blade	70-42572-01 (2)	70-42572-01 (3)	70-42572-03 (3)	70-42572-01 (2)	70-42572-01 (3)	70-42572-03 (3)
27		Cap/Rain Shield	56-17070-01 (2)	56-17070-01 (3)	56-17070-01 (3)	56-17070-01 (2)	56-17070-01 (3)	56-17070-01 (3)
28		Motor Mount - Outdoor Fan	70-42504-01 (2)	70-42504-01 (3)	70-42504-01 (3)	70-42504-01 (2)	70-42504-01 (3)	70-42504-01 (3)

No.	Notes	MODEL COOLING CAPACITY ELECTRICAL DESIGNATION	RAWL 150 Y	RAWL 180 Y	RAWL 240 Y			
FAN GROUP								
24	Stk	Fan Motor	51-42534-03 (2)	51-42534-03 (3)	51-42534-11 (3)			
		Motor Wiring Harness	45-42522-60	45-42522-56	45-42522-56			
25	Stk	Capacitor - Fan Motor	43-100496-12 (2)	43-100496-12 (3)	43-100496-03 (3)			
26	Stk	Fan Blade	70-42572-01 (2)	70-42572-01 (3)	70-42572-03 (3)			
27		Cap/Rain Shield	56-17070-01 (2)	56-17070-01 (3)	56-17070-01 (3)			
28		Motor Mount - Outdoor Fan	70-42504-01 (2)	70-42504-01 (3)	70-42504-01 (3)			
29		Heat Sink	77-42426-01 (4)	77-42426-01 (2)	77-42426-01 (2)			
		Heat Sink Clip	77-42427-01 (2)	77-42427-01 (1)	77-42427-01 (1)			

No.	Notes	MODEL COOLING CAPACITY VARIATION	RAWL 079 CAZ	RAWL 079 DAZ	RAWL 091 CAZ	RAWL 091 DAZ
ELECTRICAL GROUP						
	Stk	Control Transformer	46-41930-01	46-41930-01	46-41930-01	46-41930-01
25		Crankcase Heater	See Compressor Group			
26		Grounding Lug	45-19000-01	45-19000-01	45-19000-01	45-19000-01
		Low Ambient Control	See Accessories Group			
27	Stk	Low Pressure Control	47-103670-08	47-103670-08	47-103670-08	47-103670-08
27a		Valve Body - Low Pressure Control	61-18542-01	61-18542-01	61-18542-01	61-18542-01
28	Stk	High Pressure Control	47-102290-01	47-102290-01	47-102290-01	47-102290-01
FAN GROUP						
20	Stk	Fan Motor	51-105035-06	51-105035-07	51-105035-06	51-105035-07
21	Stk	Fan Blade	70-102345-15	70-102345-15	70-102345-15	70-102345-15
22	Stk	Contactora	42-102664-08	42-102664-08	42-102664-12	42-102664-12

No.	Notes	MODEL COOLING CAPACITY VARIATION	RAWL 079 CAZ	RAWL 079 DAZ	RAWL 091 CAZ	RAWL 091 DAZ
COIL GROUP						
30	Stk	Condenser Coil	AS-105371-04	AS-105371-04	AS-106748-01	AS-106748-01
31		Service Valve - Suction	61-106734-02	61-106734-02	61-106734-02	61-106734-02
32		Service Valve - Liquid	61-106734-01	61-106734-01	61-106734-01	61-106734-01
33a		Valve Core	61-18551-01	61-18551-01	61-18551-01	61-18551-01
33b		Valve Cap	83-100635-01	83-100635-01	83-100635-01	83-100635-01
		Filter Drier	83-22755-17	83-22755-17	83-22755-17	83-22755-17
27	Stk	Low Pressure Control	See Electrical Group			
28	Stk	High Pressure Control	See Electrical Group			

No.	Notes	MODEL COOLING CAPACITY	RAWL 078	RAWL 090	
COIL GROUP					
2	Stk	Condenser Coil	AS-102624-01	AS-102625-01	
12	Stk	High Pressure Control	47-23699-05	47-23699-05	
		Distributor - 4 Way (1/2 in. to 3/8 in.) - w/o Liquid Tubes	83-17467-23	N/A	
13a		Service Valve (Liquid)	61-21368-12	61-21368-12	
13b		Service Valve (Suction) - Before F4310	61-102832-04	61-102832-04	
13b		Service Valve (Suction) - After F4310	61-102832-07	61-102832-07	
18	Stk	Low Ambient Control	47-102478-01	47-102478-01	
	Stk	Low Pressure Control	47-101529-09	47-101529-09	
	Stk	Filter Drier	83-22755-10	83-22755-10	

No.	Notes	MODEL COOLING CAPACITY	RAWL 120	RAWL 121	RAWL 125
COIL GROUP					
21	Stk	Condenser Coil (2)	AS-90900-02	AS-90900-10	AS-90900-07
		Distributor - 2 Way (1/2 in. to 3/8 in.) - w/o Liquid Tubes	83-19988-01	83-19988-01	N/A
		Distributor - 2 Way (3/4 in. to 3/4 in.) - w/o Liquid Tubes	N/A	83-17467-29	83-17467-29
22		Gauge Port	AS-90948-01	AS-90948-01	AS-90948-01
23		Gauge Port	AS-90948-02	AS-90948-02	AS-90948-02
		Service Valve (Liquid)	61-21368-14	61-21368-14	61-21368-14
		Service Valve (Suction)	61-102832-02	61-102832-02	61-102832-02
37	Stk	High Pressure Control	47-23699-05	47-23699-05	47-23699-05
38	Stk	Low Pressure Control	47-101529-09	47-101529-09	47-101529-09
39	Stk	Low Ambient Control	47-102478-01	47-102478-01	47-102478-01
	Stk	Filter Drier	83-22755-13	83-22755-11	83-22755-13

No.	Notes	MODEL COOLING CAPACITY	RAWL 150	RAWL 180	RAWL 240
COIL GROUP					
21	Stk	Condenser Coil	AS-90900-03 (2)	AS-90900-04 (2)	AS-90900-05 (2)
22		Gauge Port	AS-90948-01	AS-90948-01	AS-90948-01
23		Gauge Port	AS-90948-02	AS-90948-11	AS-90948-11
		Service Valve (Liquid)	61-21368-14	61-21368-14	61-21368-16
		Service Valve (Suction)	61-102832-02	61-102832-03	61-102832-03
37	Stk	High Pressure Control	47-23699-05	47-23699-05	47-23699-05
38	Stk	Low Pressure Control	47-101529-09	47-101529-09	47-101529-09
39	Stk	Low Ambient Control	47-102478-01	47-102478-01	47-102478-01
		Filter Drier	83-22755-11	83-22755-11	83-22755-14

No.	Notes	MODEL COOLING CAPACITY VARIATION	RAWL 079 CAZ	RAWL 079 DAZ	RAWL 091 CAZ	RAWL 091 DAZ
COMPRESSOR GROUP						
		Compressor ID:	9429	9430	9432	9433
40	Stk	Compressor	55-23156-16	55-23156-17	55-23156-20	55-23156-21
		Compressor Grommet (4)	56-18518-06	56-18518-06	56-18518-06	56-18518-06
		Compressor Bolt (4)	63-20072-07	63-20072-07	63-20072-07	63-20072-07
25		Crankcase Heater	44-17402-10	44-17402-11	44-17402-10	44-17402-11

No.	Notes	MODEL COOLING CAPACITY ELECTRICAL DESIGNATION	RAWL 078 C	RAWL 078 D	RAWL 078 Y	RAWL 090 C	RAWL 090 D	RAWL 090 Y
COMPRESSOR GROUP								
		Compressor ID:	7747	7748	7749	7753	7754	7755
11	Stk	Compressor	55-23156-16S	55-23156-17S	55-23156-18S	55-23156-20S	55-23156-21S	55-23156-22S
	Stk	Crankcase Heater	44-17402-10	44-17402-11	44-17402-12	44-17402-10	44-17402-11	44-17402-12

No.	Notes	MODEL COOLING CAPACITY ELECTRICAL DESIGNATION	RAWL 120 C	RAWL 120 D	RAWL 120 Y	RAWL 121 C	RAWL 121 D	
COMPRESSOR GROUP								
		Compressor ID:	7759	7760	7761	9439	9440	
30	Stk	Compressor	55-102471-01S	55-102471-04S	55-102471-05S	55-23156-56	55-23156-57	
31	Stk	Crankcase Heater	44-17402-17	44-17402-18	44-17402-19	44-17402-22	44-17402-23	

No.	Notes	MODEL COOLING CAPACITY ELECTRICAL DESIGNATION	RAWL 125 C	RAWL 125 D	RAWL 125 Y			
COMPRESSOR GROUP								
		Compressor ID:	7850	7851	7852			
30	Stk	Compressor	55-102477-01S	55-102477-02S	55-102477-03S			
31	Stk	Crankcase Heater	44-17402-22 (2)	44-17402-23 (2)	44-17402-24 (2)			

No.	Notes	MODEL COOLING CAPACITY ELECTRICAL DESIGNATION	RAWL 150 C	RAWL 180 C	RAWL 240 C	RAWL 150 D	RAWL 180 D	RAWL 240 D
COMPRESSOR GROUP								
		Compressor ID:	7919	7925	7931	7920	7926	7932
30	Stk	Compressor	55-102477-05S	55-102477-09S	55-102477-13S	55-102477-06S	55-102477-10S	55-102477-14S
31	Stk	Crankcase Heater	44-17402-22 (2)	44-17402-22 (2)	44-17402-17 (2)	44-17402-23 (2)	44-17402-23 (2)	44-17402-18 (2)

No.	Notes	MODEL COOLING CAPACITY ELECTRICAL DESIGNATION	RAWL 150 Y	RAWL 180 Y	RAWL 240 Y			
COMPRESSOR GROUP								
		Compressor ID:	7921	7927	7933			
30	Stk	Compressor	55-102477-07S	55-102477-11S	55-102477-15S			
31	Stk	Crankcase Heater	44-17402-24 (2)	44-17402-23 (2)	44-17402-19 (2)			

No.	Notes	MODEL COOLING CAPACITY VARIATION	RAWL 079 CAZ	RAWL 079 DAZ	RAWL 091 CAZ	RAWL 091 DAZ
ACCESSORIES						
		Low Ambient Control	RXAD-A08	RXAD-A08	RXAD-A08	RXAD-A08

No.	Notes	MODEL COOLING CAPACITY	RAWL 078	RAWL 090	RAWL 120/121	RAWL 125
ACCESSORY GROUP						
		Anti-Short Cycle Timer Kit	RXAT-A01	RXAT-A01	N/A	N/A
		Liquid Line Solenoid Valve	RXAV-CD078	RXAV-CD078	RXAV-CD120	RXAV-CD120
		Sight Glass	RXAG-A048	RXAG-A048	RXAG-A048	RXAG-A048

No.	Notes	MODEL COOLING CAPACITY	RAWL 150	RAWL 180	RAWL 240	
ACCESSORY GROUP						
		Liquid Line Solenoid Valve	RXAV-CD120	RXAV-CD180	RXAV-CD180	
		Sight Glass	N/A	RXAG-A020	RXAG-A020	

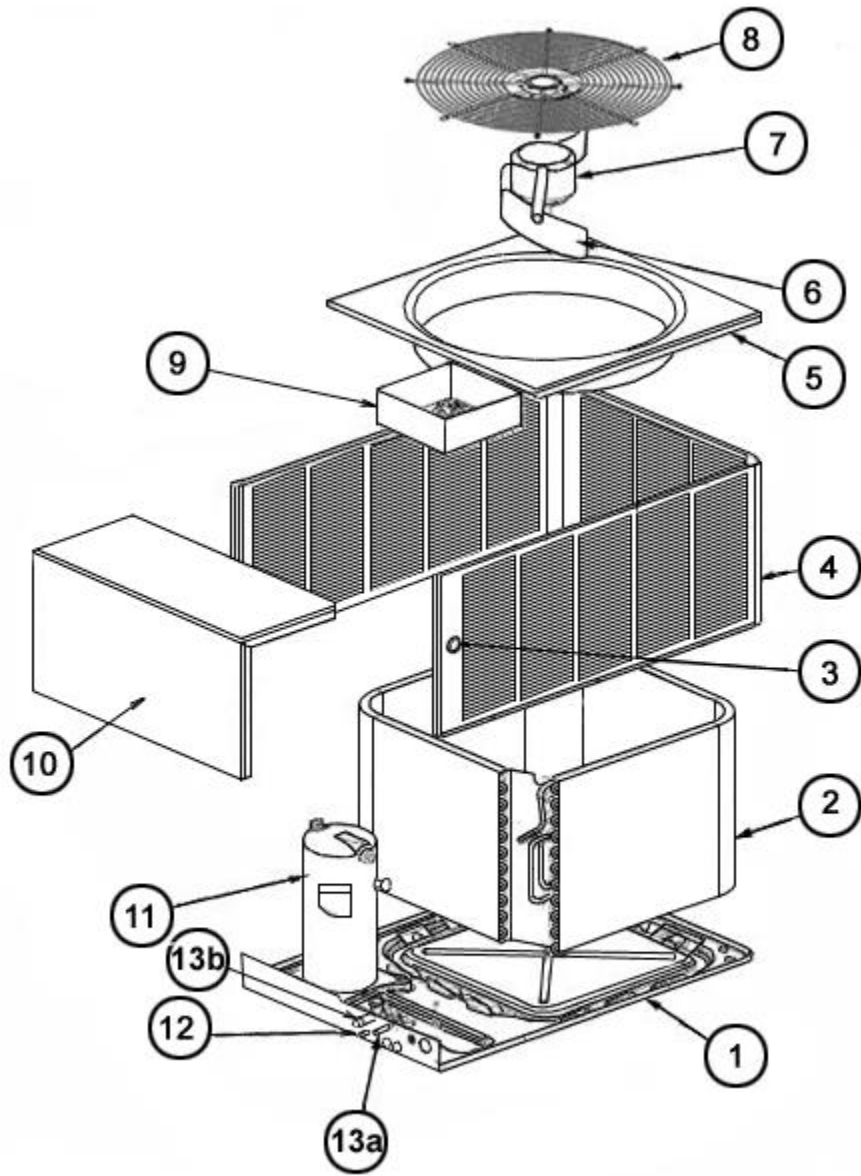

Exploded View 078-090 Old Cabinet

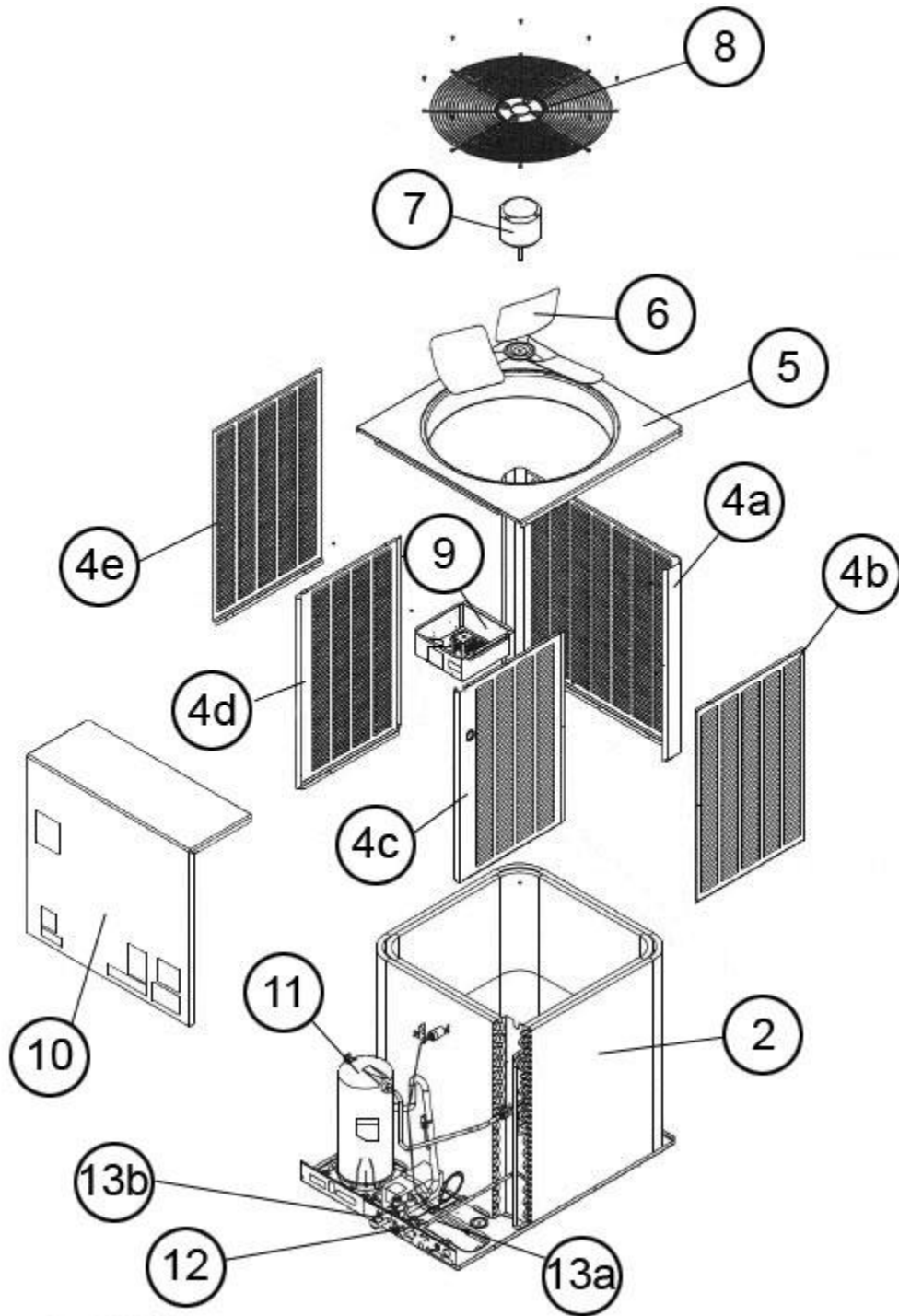

Exploded View 078-090 New Cabinet

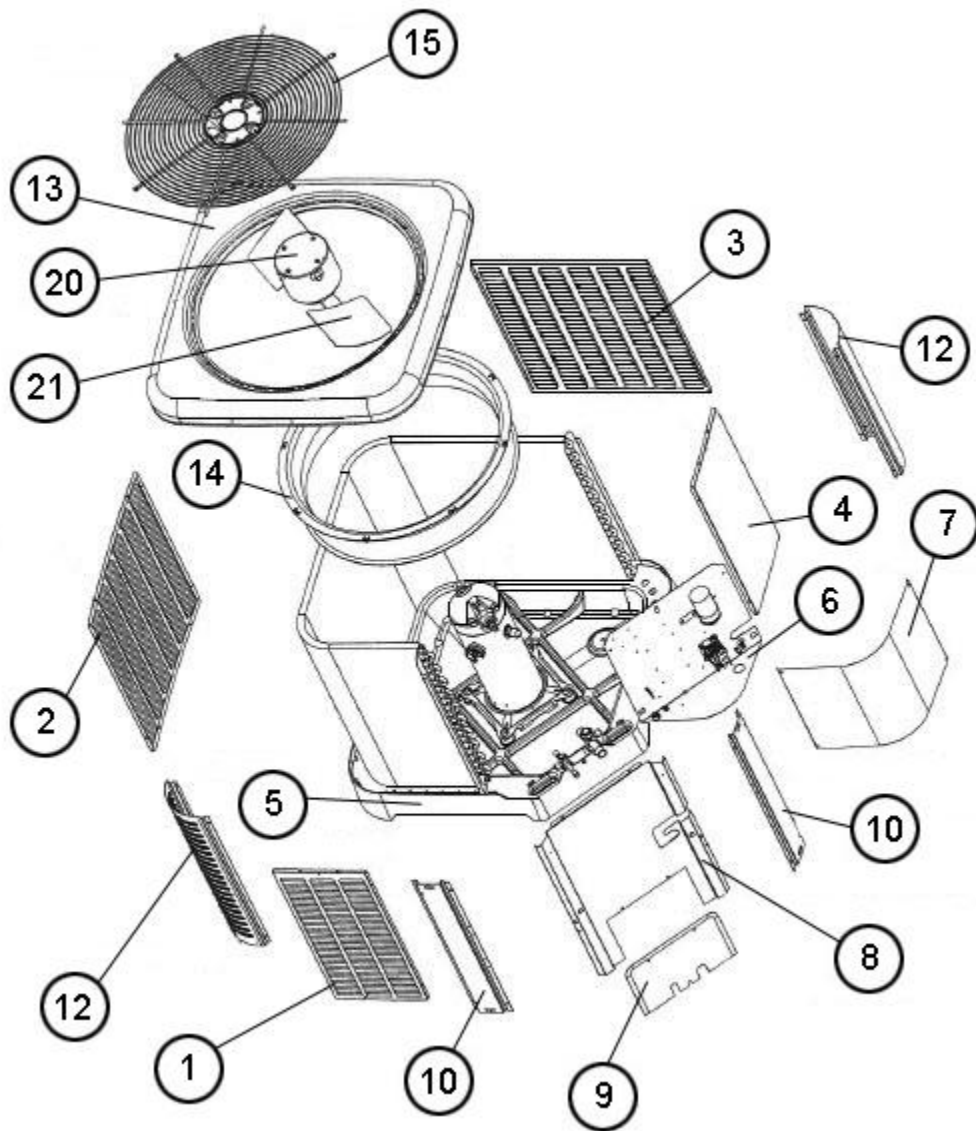

Exploded View 079-091

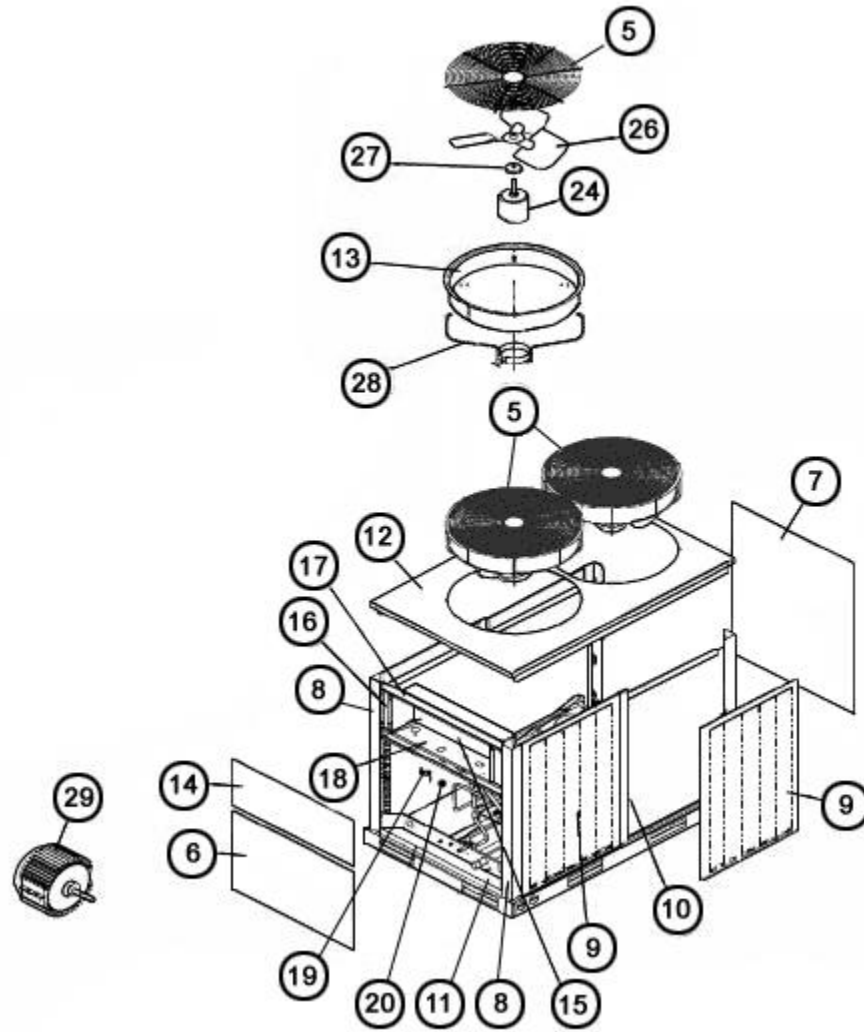

Exploded View 120-150

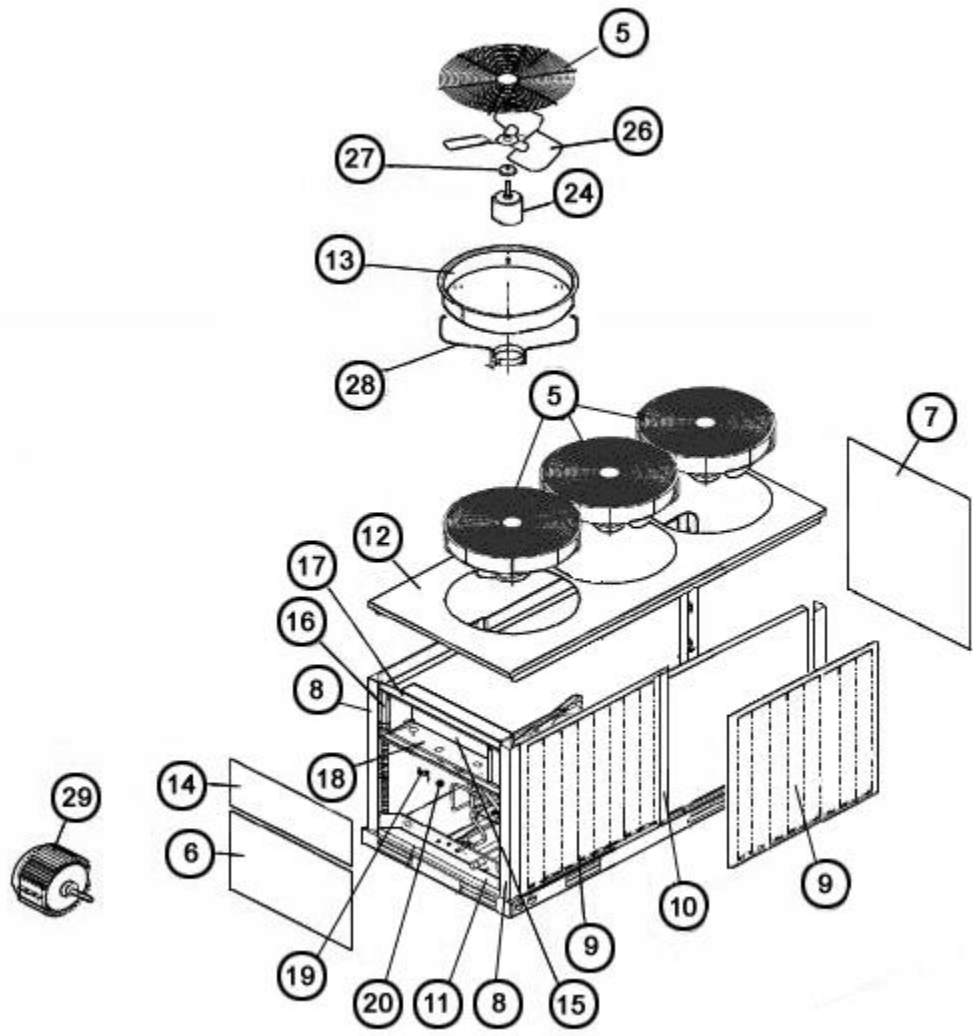

Exploded View 180-240

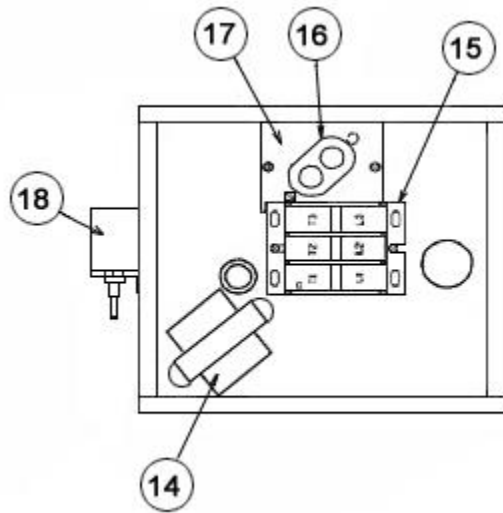

Control Box 078-090

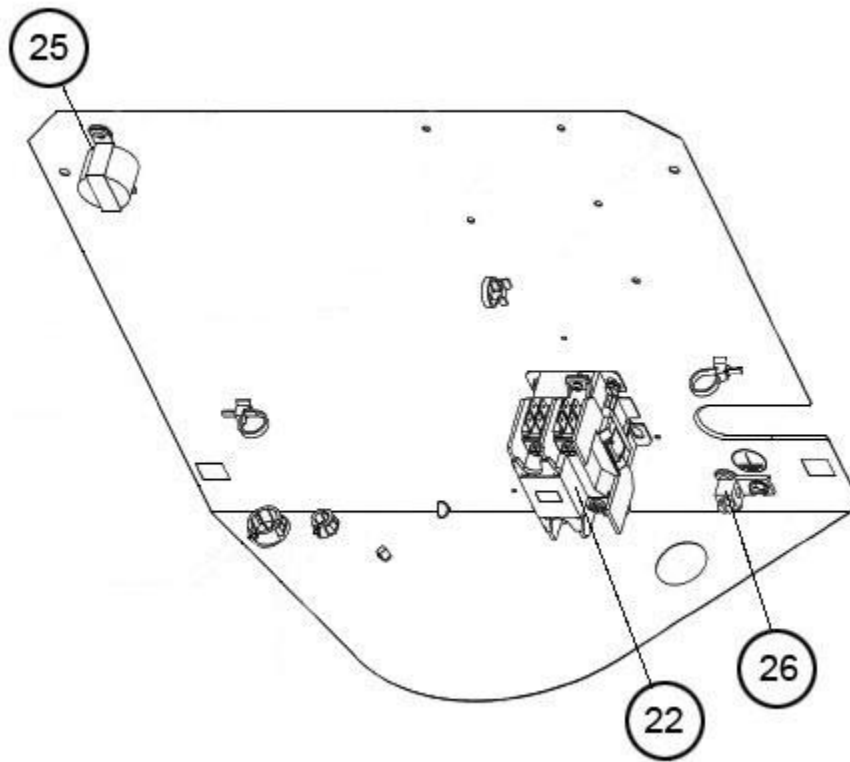

Control Box 079-091

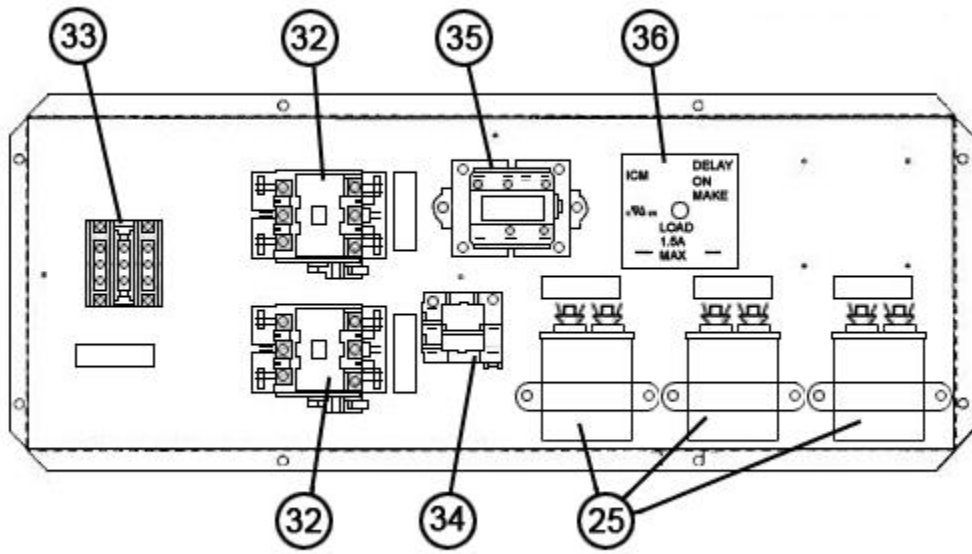

Control Box 120-240

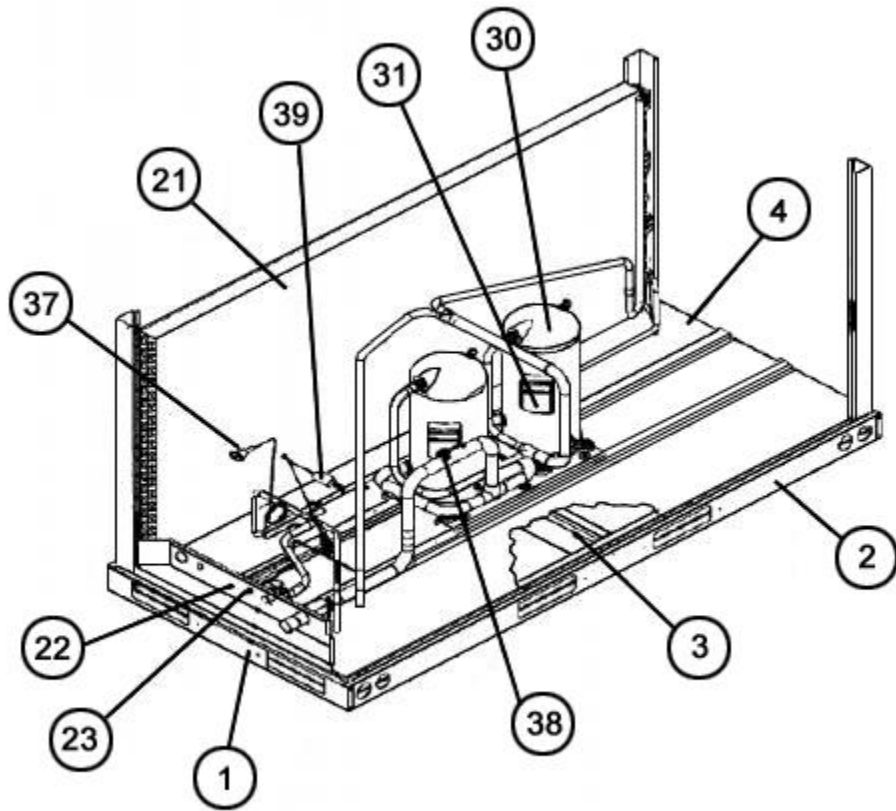

Compressor Assembly 120-240

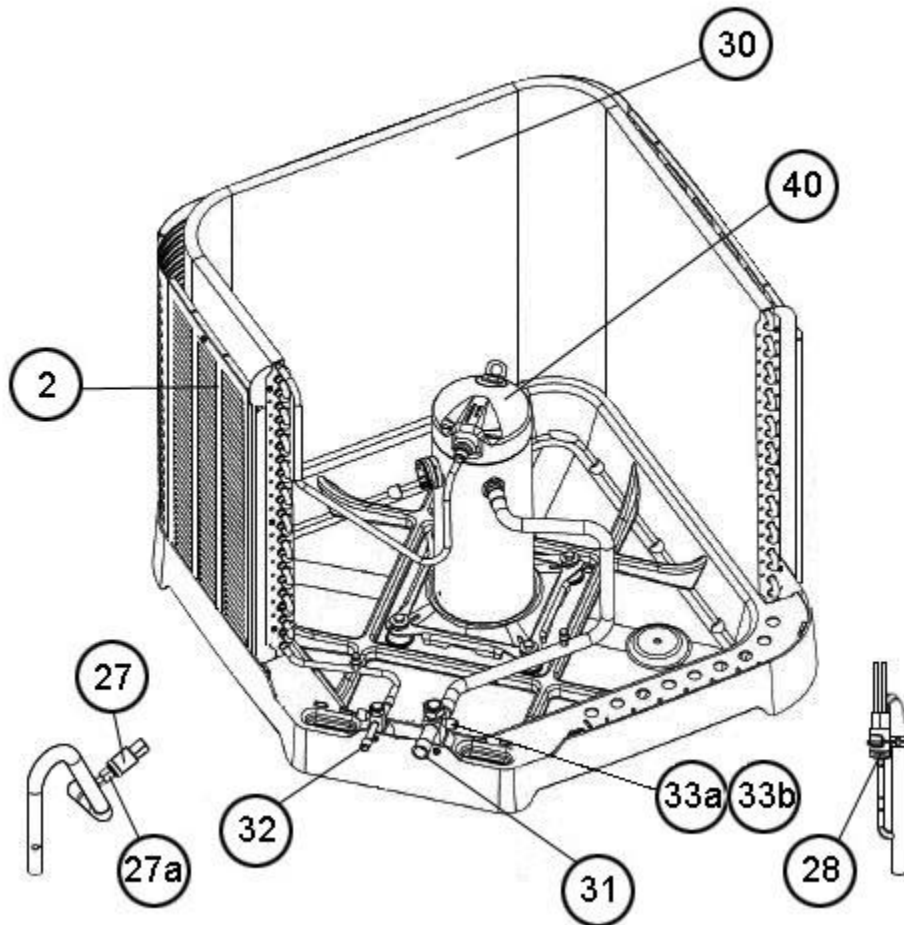

Valve Mounting, Compressor 079-091

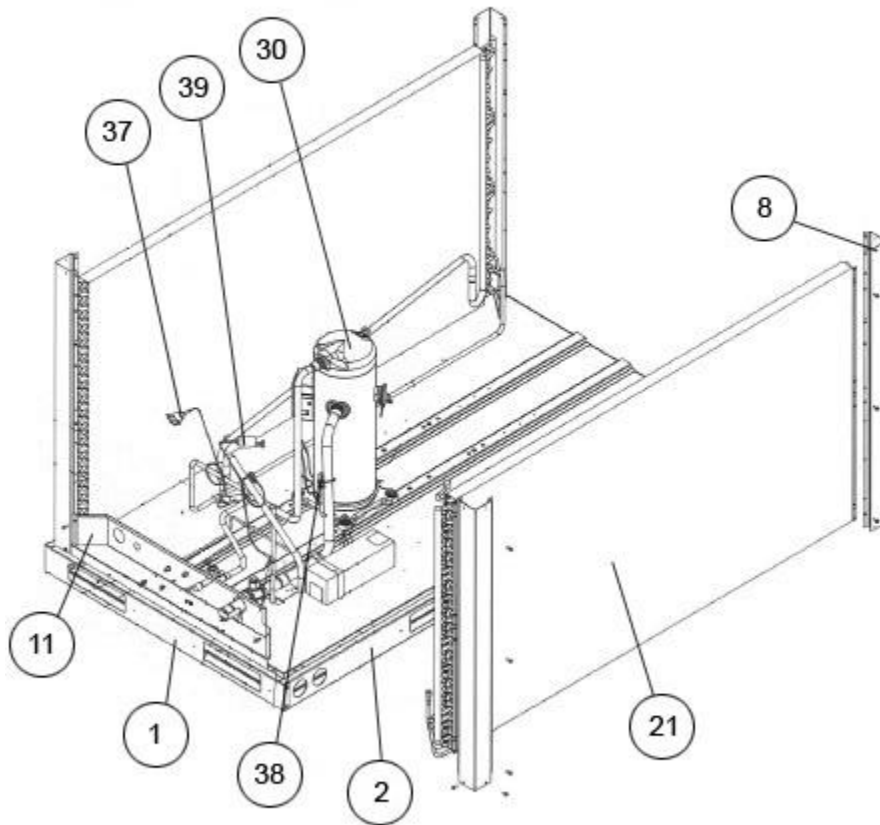

Coils - Compressor 121

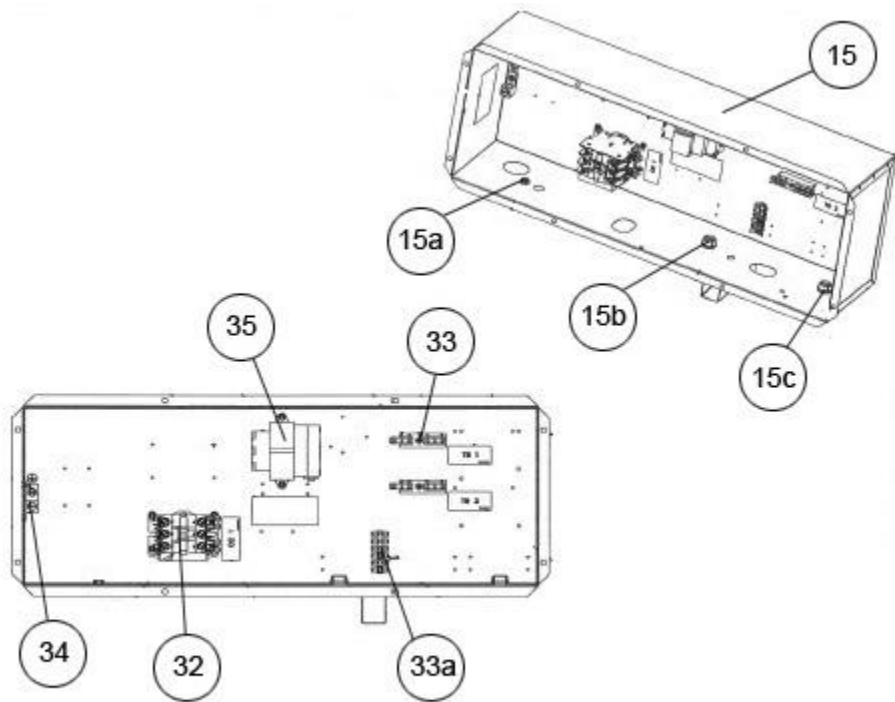

Control Box 121

NOTES

Stk It is recommended that stock be maintained for this part.
N/A Not Applicable

DISCLAIMER: This document is intended to provide general replacement parts information to aid qualified service personnel in the repair of these models. The complete Model and Serial Number of the unit under repair should be specified when selecting and ordering replacement parts. Specifications and illustrations are subject to change without notice. Document 92-42800-RAWL supersedes all previous parts lists for these models. See <http://www.rheempartslists.net/92-42800-RAWL> for the latest revision of this document. The manufacturer assumes no obligation for errors or omissions. Service personnel must verify the proper and safe operation of equipment after the replacement of any original components.