

INSTALLATION INSTRUCTIONS

HIGH-EFFICIENCY CONDENSING UNITS

FEATURING EARTH-FRIENDLY R-410A REFRIGERANT 

RAWL - 6½ & 7½ TON

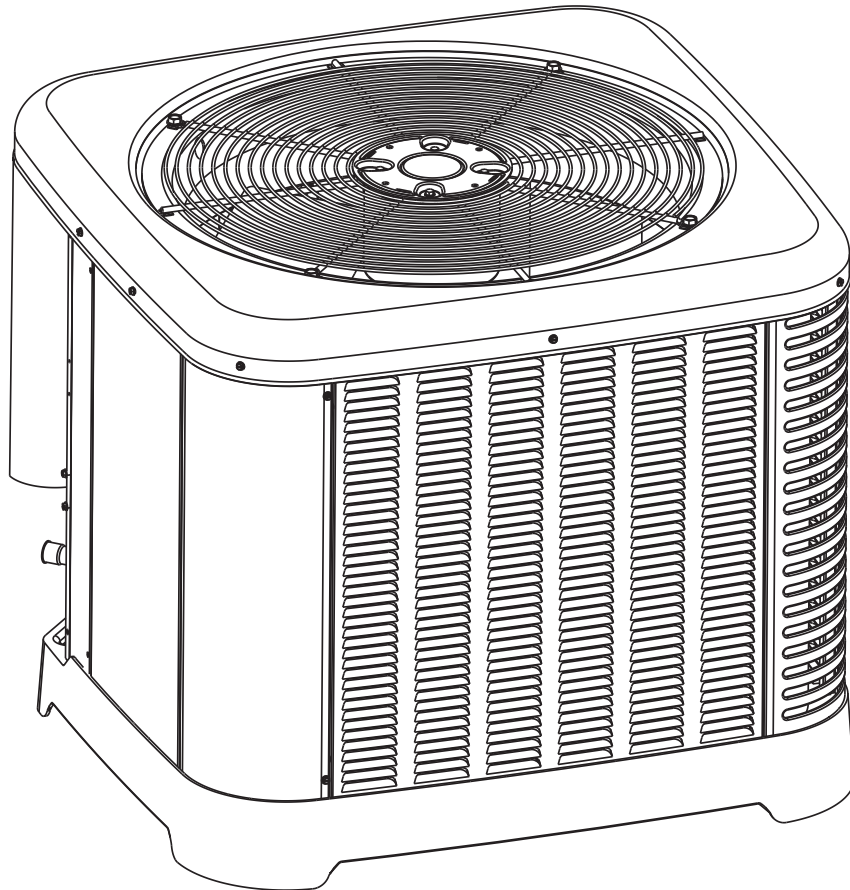

RECOGNIZE THIS SYMBOL AS AN INDICATION OF IMPORTANT SAFETY INFORMATION!

WARNING

THESE INSTRUCTIONS ARE INTENDED AS AN AID TO QUALIFIED, LICENSED SERVICE PERSONNEL FOR PROPER INSTALLATION, ADJUSTMENT AND OPERATION OF THIS UNIT. READ THESE INSTRUCTIONS THOROUGHLY BEFORE ATTEMPTING INSTALLATION OR OPERATION. FAILURE TO FOLLOW THESE INSTRUCTIONS MAY RESULT IN IMPROPER INSTALLATION, ADJUSTMENT, SERVICE OR MAINTENANCE POSSIBLY RESULTING IN FIRE, ELECTRICAL SHOCK, PROPERTY DAMAGE, PERSONAL INJURY OR DEATH.



ISO 9001:2008
Certificate Number: 30164

DO NOT DESTROY THIS MANUAL

PLEASE READ CAREFULLY AND KEEP IN A SAFE PLACE FOR FUTURE REFERENCE BY A SERVICEMAN

[] INDICATES METRIC CONVERSIONS



TABLE OF CONTENTS

I. SAFETY INFORMATION	3
II. INTRODUCTION	4
III. CHECKING PRODUCT RECEIVED	4
IV. EQUIPMENT PROTECTION	4
V. GENERAL INFORMATION	5
VI. PERFORMANCE/PHYSICAL/ELECTRICAL	6
Performance Data	6
Physical and Electrical Data	7
VII. INSTALLATION	7
A. Important Message to Owner	7
B. Inspection and Handling	7
C. Order Parts	8
D. Standard Items	8
E. General Installation	8
F. Rooftop Installation	8
G. Slab Installation	8
VIII. REFRIGERANT PIPING DATA	9
A. Installation of Piping	10
B. Typical Piping Recommendations	11-12
VIX. WIRING	13
X. ELECTRICAL POWER	13
XI. POWER WIRING	13
XII. WIRE ROUTING	13
XIII. GROUNDING	13
XIV. THERMOSTAT – 6½ & 7½ TON	13
XV. LEAK TESTING	13
XVI. R-410A REFRIGERANT	14
A. Tools Required for Installing & Servicing R-410A Models	14
B. Specification of R-410A	14
C. Quick Reference Guide for R-410A	14
D. Replacement Units	15
E. Evaporator Coil	15
XVII. EVACUATION & CHARGING	15
XVIII. SEQUENCE OF OPERATION – 6½ & 7½ TON	17
XIX. ACCESSORIES	17
A. Anti-Short Cycle Timer	17
B. Discharge Pressure Control	18
C. Liquid Line Solenoid Valve	18
D. Sight Glass	18
XX. MISCELLANEOUS	19
A. Charge Charts	19-20
B. Maintenance & Operation	21
1. Contactor	21
2. High Pressure Switch (HPC)	21
3. Low Pressure Switch (LPC)	21
4. Pre-Start Check	21
C. Troubleshooting	22
Wiring Diagram & Schematic	23

► Installation Instructions are updated on a regular basis. This is done as product changes occur or if new information becomes available. In this publication, an arrow (►) denotes changes from the previous edition or additional new material.

WARNING

Important: All manufacturer products meet current Federal OSHA Guidelines for safety. California Proposition 65 warnings are required for certain products, which are not covered by the OSHA standards.

California's Proposition 65 requires warnings for products sold in California that contain, or produce, any of over 600 listed chemicals known to the State of California to cause cancer or birth defects such as fiberglass insulation, lead in brass, and combustion products from natural gas.

All "new equipment" shipped for sale in California will have labels stating that the product contains and/or produces Proposition 65 chemicals. Although we have not changed our processes, having the same label on all our products facilitates manufacturing and shipping. We cannot always know "when, or if" products will be sold in the California market.

You may receive inquiries from customers about chemicals found in, or produced by, some of our heating and air-conditioning equipment, or found in natural gas used with some of our products. Listed below are those chemicals and substances commonly associated with similar equipment in our industry and other manufacturers.

- Glass Wool (Fiberglass) Insulation
- Carbon Monoxide (CO)
- Formaldehyde
- Benzene

More details are available at the Websites for OSHA (Occupational Safety and Health Administration), at www.osha.gov and the State of California's OEHHA (Office of Environmental Health Hazard Assessment), at www.oehha.org. Consumer education is important since the chemicals and substances on the list are found in our daily lives. Most consumers are aware that products present safety and health risks, when improperly used, handled and maintained.

NOTICE

BREAK-IN PERIOD

Prior to agency testing, the compressor ran for 20 hours at 115°F outdoor ambient temperature and 80° dry bulb/75° wet bulb indoor ambient temperature.

NOTICE

EFFICIENCY TESTING NOTICE

For purposes of verifying or testing efficiency ratings, the test procedure in Title 10 Part 431 Appendix A to Subpart F (Uniform Test Method for Measuring the Energy Consumption of Small Large and Very Large Commercial Package Air Conditioning and Heating Equipment), and the clarifying provisions provided in the AHRI Operations Manuals for Unitary Large Equipment 340/360, 365 that were applicable at the date of manufacture should be used for test set up and performance.

1.0 SAFETY INFORMATION

WARNING

THESE INSTRUCTIONS ARE INTENDED AS AN AID TO QUALIFIED LICENSED SERVICE PERSONNEL FOR PROPER INSTALLATION, ADJUSTMENT AND OPERATION OF THIS UNIT. READ THESE INSTRUCTIONS THOROUGHLY BEFORE ATTEMPTING INSTALLATION OR OPERATION. FAILURE TO FOLLOW THESE INSTRUCTIONS MAY RESULT IN IMPROPER INSTALLATION, ADJUSTMENT, SERVICE OR MAINTENANCE POSSIBLY RESULTING IN FIRE, ELECTRICAL SHOCK, PROPERTY DAMAGE, PERSONAL INJURY OR DEATH.

WARNING

DISCONNECT ALL POWER TO THE UNIT BEFORE STARTING MAINTENANCE. FAILURE TO DO SO CAN RESULT IN SEVERE ELECTRICAL SHOCK OR DEATH.

WARNING

DO NOT USE OXYGEN TO PURGE LINES OR PRESSURE SYSTEM FOR LEAK TEST. OXYGEN REACTS VIOLENTLY WITH OIL, WHICH CAN CAUSE AN EXPLOSION RESULTING IN SEVERE PERSONAL INJURY OR DEATH.

WARNING

AFTER COMPLETION OF WIRING CHECK ALL ELECTRICAL CONNECTIONS, INCLUDING FACTORY WIRING WITHIN THE UNIT, AND MAKE SURE ALL CONNECTIONS ARE TIGHT, REPLACE AND SECURE ALL ELECTRICAL BOX COVERS AND ACCESS DOORS BEFORE LEAVING UNIT OR TURNING ON POWER TO CIRCUIT SUPPLY UNIT. FAILURE TO DO SO CAN CAUSE A FIRE OR ELECTRICAL SHOCK RESULTING IN PROPERTY DAMAGE, PERSONAL INJURY OR DEATH.

WARNING

THIS UNIT MUST BE PERMANENTLY GROUNDED. A GROUND LUG IS PROVIDED NEAR THE CONTACTOR FOR A GROUND WIRE. FAILURE TO DO SO CAN CAUSE A FIRE OR ELECTRICAL SHOCK RESULTING IN PROPERTY DAMAGE, SEVERE PERSONAL INJURY OR DEATH.

CAUTION

R-410A systems operate at higher pressures than R-22 systems. Do not use R-22 service equipment or components on R-410A equipment.

CAUTION

Only use evaporators approved for use on R-410A systems. Use of existing R-22 evaporators can introduce mineral oil to the R-410A refrigerant forming two different liquids and decreasing oil return to the compressor. This can result in compressor failure.

II. INTRODUCTION

This booklet contains the installation and operating instructions for your self-contained air conditioner. There are a few precautions that should be taken to derive maximum satisfaction from it. Improper installation can result in unsatisfactory operation or dangerous conditions.

Read this booklet and any instructions packaged with separate equipment required to make up the system prior to installation. Give this booklet to the owner and explain its provisions. The owner should retain this booklet for future reference.

III. CHECKING PRODUCT RECEIVED

Upon receiving the unit, inspect it for any damage from shipment. Claims for damage, either shipping or concealed, should be filed immediately with the shipping company. Check the unit model number, electrical characteristics, and accessories to determine if they are correct.

IV. EQUIPMENT PROTECTION FROM THE ENVIRONMENT

The metal parts of this unit may be subject to rust or deterioration in adverse environmental conditions. This oxidation could shorten the equipment's useful life. Salt spray, fog or mist in seacoast areas, sulphur or chlorine from lawn watering systems, and various chemical contaminants from industries such as paper mills and petroleum refineries are especially corrosive.

If the unit is to be installed in an area where contaminants are likely to be a problem, special attention should be given to the equipment location and exposure.

1. Avoid having lawn sprinkler heads spray directly on the unit cabinet.
2. In coastal areas, locate the unit on the side of the building away from the waterfront.
3. Shielding provided by a fence or shrubs may give some protection.
4. Elevating the unit off its slab or base enough to allow air circulation will help avoid holding water against the basepan.

Regular maintenance will reduce the buildup of contaminants and help to protect the unit's finish.



WARNING

DISCONNECT ALL POWER TO THE UNIT BEFORE STARTING MAINTENANCE. FAILURE TO DO SO CAN RESULT IN SEVERE ELECTRICAL SHOCK OR DEATH.

1. Frequent washing of the cabinet, fan blade and coil with fresh water will remove most of the salt or other contaminants that build up on the unit.
2. Regular cleaning and waxing of the cabinet with an automobile polish will provide some protection.
3. A liquid cleaner may be used several times a year to remove matter that will not wash off with water.

Several different types of protective coatings are offered in some areas. These coatings may provide some benefit, but the effectiveness of such coating materials cannot be verified by the equipment manufacturer.

The best protection is frequent cleaning, maintenance and minimal exposure to contaminants.

V. GENERAL INFORMATION

CORNER WEIGHTS (Pounds)

UNIT MODEL	TOTAL WEIGHT LBS [kg]	CORNER WEIGHTS, LBS. [kg]			
		A	B	C	D
RAWL-079	245	71	54	84	36
RAWL-091	313	91	69	107	46

UNIT DIMENSIONS

(-)AWL	-079	-091
Height "H" Inches [mm]	45 [1143]	51 [1295]
Length "L" Inches [mm]	35.75 [908]	35.75 [908]
Width "W" Inches [mm]	35.75 [908]	35.75 [908]

FIGURE 1
UNIT DIMENSIONS — 6½ & 7½ TON

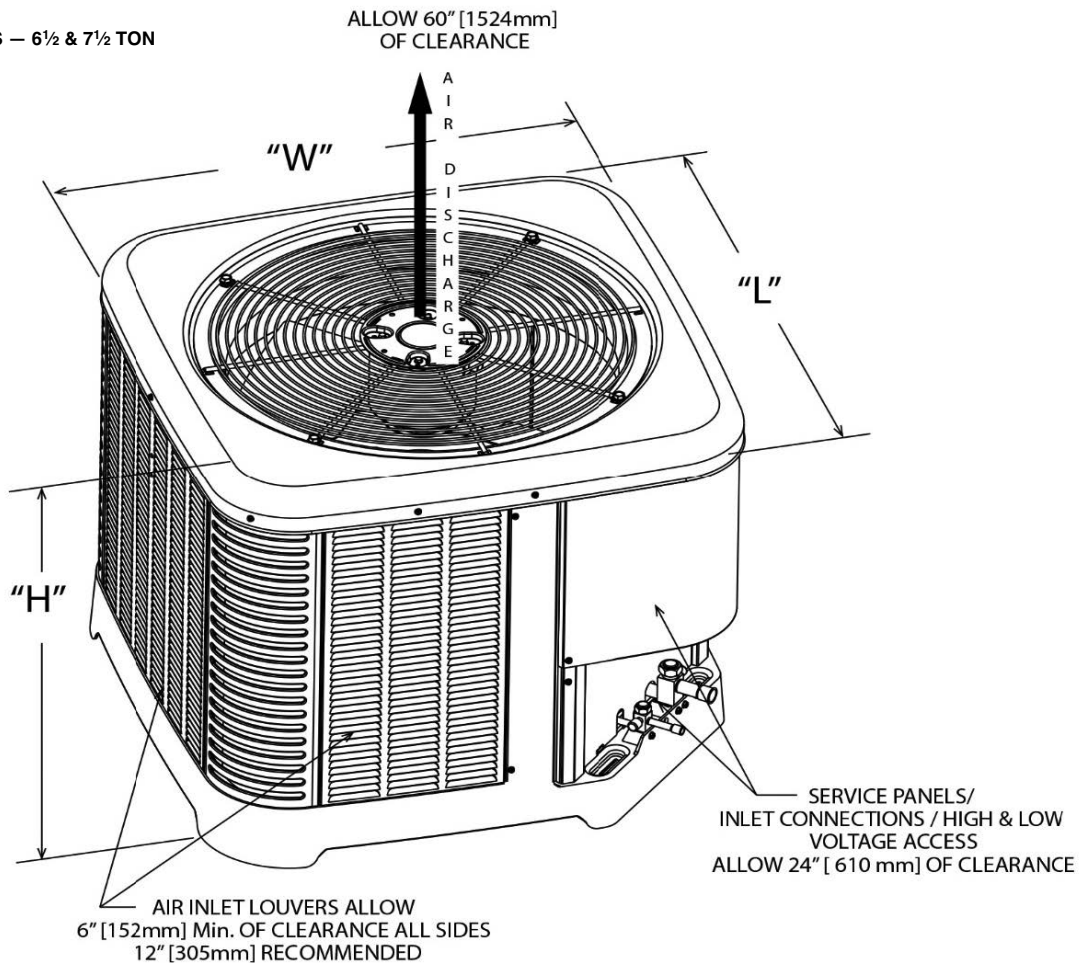

ST-A1226-02-00

VI. STANDARD UNIT FEATURES – 6½ AND 7½ TON

CABINET — Galvanized steel with a durable powder coat paint finish. The cabinet front and sides are formed into a one piece unitized design with stamped louvers to provide protection for the condenser coils.

SERVICE ACCESS — Control box with separation between line and control voltages, as well as compressor and other refrigerant controls are accessible through removable top and side panels (without affecting normal operation of unit).

Condenser fan motors are mounted on removable top panels which bring the motors out to you and expose entire condenser coil for cleaning.

COMPRESSOR — Hermetically sealed with internal high temperature protection and durable insulation on motor windings. The compressor is mounted on rubber grommets to reduce vibration and noise.

CONDENSER COILS — Constructed with copper tubes and aluminum fins mechanically bonded to tubes for maximum heat transfer capabilities. All coil assemblies are leak tested.

REFRIGERANT CONNECTIONS — All field sweat joints are made external of the unit and are located close to the ground for a neat looking installation.

LOW AMBIENT CONTROL — A pressure sensitive fan cycling control allows operation of units down to 0°F.

HIGH PRESSURE CONTROL — Manual reset control deactivates system if abnormally high pressure occurs.

LOW PRESSURE CONTROL — Automatic reset control deactivates system if abnormally low pressure or refrigerant loss occurs.

SERVICE VALVES — Standard on liquid line and suction line. Allows outdoor section to be isolated from indoor coil.

FILTER DRIER — Standard, field installed. Helps maintain system cleanliness.

CONDENSER FAN MOTORS — Direct-drive, PSC single-phase motors.

TRANSFORMER — Step down type, from Line to 24 volts.

CONTACTOR — The contactor is an electrical switch which operates the compressor and condenser fans. Its 24 volt coil is activated through the High Pressure Control and Low Pressure Control on a call for cooling.

CAPACITORS — Help provide starting torque necessary to boost the condenser fan motors to operating speed by directing their stored energy to the starter winding in step with the running winding.

EQUIPMENT GROUND — Lug for field connection of ground wire.

TESTING — All units are run tested at the factory prior to shipment.

VI. PERFORMANCE DATA @ AHRI STANDARD CONDITIONS

MODEL NUMBERS		80°F [26.5°C] DB 67°F [19.5°C] WB INDOOR AIR 95°F [35°C] DB OUTDOOR AIR					SOUND RATING	RATED INDOOR CFM [L/s]
OUTDOOR UNIT RAWL-	INDOOR COIL AND/OR AIR HANDLER	TOTAL CAPACITY BTU/H [Kw]	NET SENSIBLE BTU/H [Kw]	NET LATENT BTU/H [Kw]	EER	IEER		
079CAZ	RHGL-090Z ^①	77,000 [22.5]	56,700 [16.6]	20,300 [5.95]	11.50	12.90	8.6	2575 [1215]
079DAZ	RHGL-090Z	77,000 [22.5]	56,700 [16.6]	20,300 [5.95]	11.50	12.90	8.6	2575 [1215]
091CAZ	RHGL-090Z ^①	90,000 [26.4]	64,400 [18.9]	25,600 [7.5]	11.50	12.90	8.6	2725 [1286]
	RHGL-120Z	92,000 [26.9]	65,500 [19.2]	26,500 [7.7]	11.60	13.00	8.6	2800 [1321]
091DAZ	RHGL-090Z	90,000 [26.4]	64,400 [18.9]	25,600 [7.5]	11.50	12.90	8.6	2725 [1286]
	RHGL-120Z	92,000 [26.9]	65,500 [19.2]	26,500 [7.7]	11.60	13.00	8.6	2800 [1321]

^① Highest sales volume tested combination required by D.O.E. test procedures.

[] Designates Metric Conversions

TABLE 1
PHYSICAL AND ELECTRICAL DATA TABLE (RAWL-)

Condensing Unit	079	091
Operating Weight (lbs) [kg]	245 [111.1]	307 [139.2]
Shipping Weight (lbs) [kg]	252 [114.3]	313 [141.9]
Compressor:		
Quantity	1	1
Type	Scroll	
RPM	3500	
Condenser Fans:		
Quantity	1	1
CFM [L/s]	5700 [2690]	5700 [2690]
Diameter (in.) [mm]	26 [660]	26 [660]
Motor Horsepower (ea.) [W]	1/2 [373]	1/2 [373]
Type	ECM	ECM
RPM	975	975
CONDENSER COIL:		
Quantity	1	1
Rows	1	2
Fins per Inch	22	22
Square Feet [m2]	28.38 [2.64]	32.44 [3.01]
Fins/Tubes	Aluminum / Copper	
	3/8 [10]	3/8 [10]

ELECTRICAL DATA TABLE (RAWL -)

MODEL NO. RAWL-	079CAZ	079DAZ	091CAZ	091DAZ
COMPRESSOR MOTOR: Electrical Characteristics	208/230-3-60	460-3-60	208/230-3-60	460-3-60
OPERATING CURRENT: Rated Load Amps	25	11.8	27.9	13.6
Locked Rotor Amps	149	83	164	100
CONDENSER FAN MOTORS: Volts & Phase	208/230-1	460-1	208/230-1	460-1
Full Load Amps (each)	5.3	2.2	5.3	2.2
SYSTEM CHARACTERISTICS: Unit FLA	27.7	15.9	30.3	17.5
Minimum Circuit Ampacity	34	19	37	21
Max. Fuse Size or HACR Circuit Breaker Ampacity	50/40	25/25	60/45	30/25
Disconnect Size	60	30	65	35

NOTE: N.E.C., C.E.C and local codes take precedence over suggested wire and fuse size.
[] Designates Metric Conversion

VII. INSTALLATION

A. IMPORTANT MESSAGE TO OWNER

The manufacturer assumes no responsibility for equipment installed in violation of any code or regulation. The operation portion of this manual gives instructions as to the service and care of the unit. It is recommended that the installer go over the operational portion of this manual with the owner so that there is a full understanding of the equipment and how it is intended to function.

These instructions should be read and kept for future reference. It is suggested that this booklet be affixed to or adjacent to the indoor equipment. It is addressed to your dealer and serviceman, but we highly recommend that you read it—paying particular attention to the section titled “MAINTENANCE.”

B. INSPECTION AND HANDLING

Inspect exterior of unit for evidence of rough handling in shipment. If damage is found, enter claim at once. Unpack carefully after moving unit to approximate location. Any damage should be reported immediately to the transportation company.

Material in this shipment was inspected at the factory and released to the common carrier with no known damage.

C. ORDER PARTS

When reporting shortages or damaged parts, or when ordering repair parts, give the complete unit model and serial numbers which are stamped on the Unit Rating Plate.

D. STANDARD ITEMS

The condensing unit consists of a completely assembled package which includes a compressor, a condenser coil, fan, fan motors, outdoor control box, factory wiring, factory tubing and fittings.

E. INSTALLATION GENERAL

The condensing unit should be installed outdoors. It should be located as near as possible to the evaporator section to keep connecting refrigerant tubing lengths to a minimum. The unit must be installed to allow a free air flow to the condenser coils.

If several units are installed adjacent to each other, care must be taken to avoid recirculation of air from one condenser to another. In all installations, adequate space must be provided for installation and servicing.

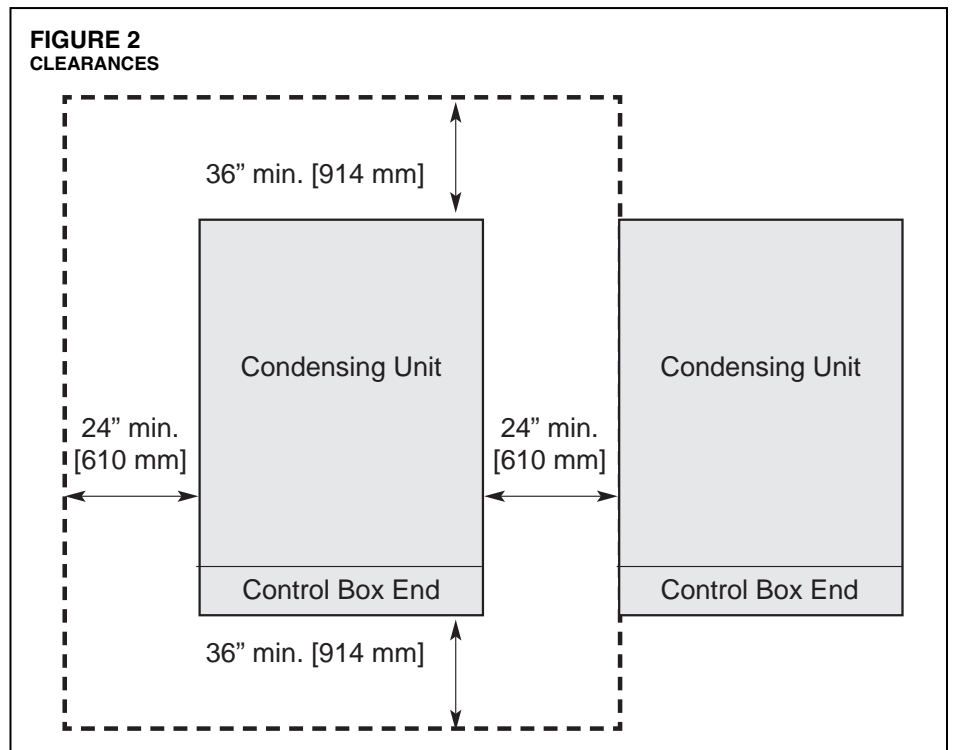

The unit must not be connected to any duct work. Do not locate unit under a roof drip; if necessary, install gutters, etc., to prevent water run-off from hitting the unit. To prevent air recirculation, it is recommended that the unit not be installed under an overhang, but if necessary **allow a minimum of 60 inches above the unit for air discharge.**

NOTE: To prevent the possibility of freeze damage, you can install an air proving switch in the air handler supply duct wired in series with the compressor contactor coil (24V) which would lock out the compressor in the event of air flow failure.

F. ROOFTOP INSTALLATION (REFER TO FIGURE 3)

If rooftop installation is required, make certain that the building construction is adequate for the weight of the unit. (Refer to physical data chart.) Before placing the unit on the roof, make certain that the nylon rigging slings are of sufficient length to maintain equilibrium of the unit when lifting. Under no circumstances should the unit be lifted by only one corner for rooftop installation.

G. SLAB INSTALLATION

Condensing units should be set on a solid level foundation. When installed at ground level, the unit should be placed on a 6 inch cement slab. If the pad is formed at the installation site, do not pour the pad tight against the structure, otherwise vibration will be transmitted from the unit through the pad.

VIII. REFRIGERANT PIPING DATA

CONDENSING UNITS ARE SHIPPED WITH A NITROGEN HOLDING CHARGE.
EVACUATE CONDENSING UNIT BEFORE CHARGING WITH REFRIGERANT.

TABLE 2
REFRIGERANT PIPING DATA

EQUIVALENT LENGTH (FT.) [m] OF STRAIGHT TYPE "L" TUBING FOR NON-FERROUS VALVES & FITTINGS (BRAZED)						
TUBE SIZE, INCHES [mm] O.D.	SOLENOID VALVE	ANGLE VALVE	SHORT RADIUS ELL	LONG RADIUS ELL	TEE LINE FLOW	TEE BRANCH FLOW
½ [13]	12 [3.7]	8.3 [2.5]	1.6 [0.5]	1.0 [0.3]	1.0 [0.3]	3.1 [0.9]
⅝ [16]	15 [4.6]	10.4 [3.2]	1.9 [0.8]	1.2 [0.4]	1.2 [0.4]	3.6 [1.1]
¾ [19]	18 [5.5]	12.5 [3.8]	2.1 [0.7]	1.4 [0.4]	1.4 [0.4]	4.2 [1.3]
⅞ [22]	21 [6.4]	14.8 [4.4]	2.4 [0.7]	1.6 [0.5]	1.6 [0.5]	4.8 [1.5]
1 ¼ [29]	12 [3.7]	18.8 [5.7]	3.0 [0.9]	2.0 [0.6]	2.0 [0.6]	6.0 [1.8]
1 ⅝ [35]	15 [4.6]	22.9 [7.0]	3.6 [1.1]	2.4 [0.7]	2.4 [0.7]	7.2 [2.2]
1 ⅞ [41]	18 [5.5]	27.1 [8.3]	4.2 [1.3]	2.8 [0.8]	2.8 [0.8]	8.4 [2.6]
2 ⅝ [54]	21 [6.4]	35.4 [10.8]	5.3 [1.6]	3.5 [1.1]	3.5 [1.1]	10.7 [3.3]

WARNING

DO NOT USE OXYGEN TO PURGE LINES OR PRESSURE SYSTEM FOR LEAK TEST. OXYGEN REACTS VIOLENTLY WITH OIL, WHICH CAN CAUSE AN EXPLOSION RESULTING IN SEVERE PERSONAL INJURY OR DEATH.

FIGURE 3
LIQUID LINE PRESSURE DROP PER 100 FEET EQUIVALENT LENGTH
(TYPE L COPPER TUBING)

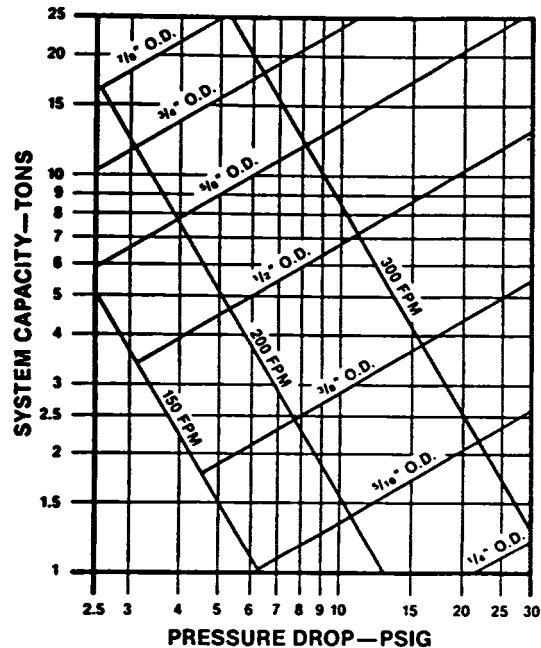

NOTES:

1. When evaporator coil is above condenser, the pressure drop due to vertical lift (.5 PSIG per foot of lift) **must** be added to the pressure drop derived from this curve.
2. Size liquid line for **no more** than 10°F loss (approximately 50 PSIG total pressure drop).
3. **Do not oversize liquid line.** Oversized liquid lines add significantly to the amount of refrigerant required to charge the system.
4. The maximum recommended velocity with solenoid valves or other quick closing devices in the liquid line is 300 FPM.

A. INSTALLATION OF PIPING

Once located, the condensing unit is ready to be interconnected with the evaporator using **ONLY** refrigeration grade dehydrated tubing. The following should be considered when connecting the tubing.

1. Pitch the suction line toward the compressor approximately $\frac{1}{2}$ inch every 10 feet to facilitate oil return.
2. It is recommended that the sight glass, filter drier and liquid line solenoid valve be installed in the liquid line just prior to the evaporator.
3. Silver solder (such as silfos, Easy Flow, etc.) should be used for all refrigerant joints.
4. Thoroughly clean all joints before fluxing. **DO NOT USE ACID FLUX.**
5. When fluxing, limit the application of paste to the minimum and always apply flux to the male portion of the connection.
6. Suction lines should be insulated to prevent condensate drip. Use insulation of at least $\frac{3}{8}$ inch wall thickness. The insulation should be installed on the tubing prior to making the sweat connections.

7. Insulate the liquid line whenever the heat pick-up or transfer can affect the sub-cooling.
8. Care should be taken to avoid transmission of noise or vibration to building structure.

FIGURE 4
SUCTION LINE SYSTEM CAPACITY LOSS IN PERCENT PER 100 FEET EQUIVALENT LENGTH
(TYPE L COPPER TUBING)

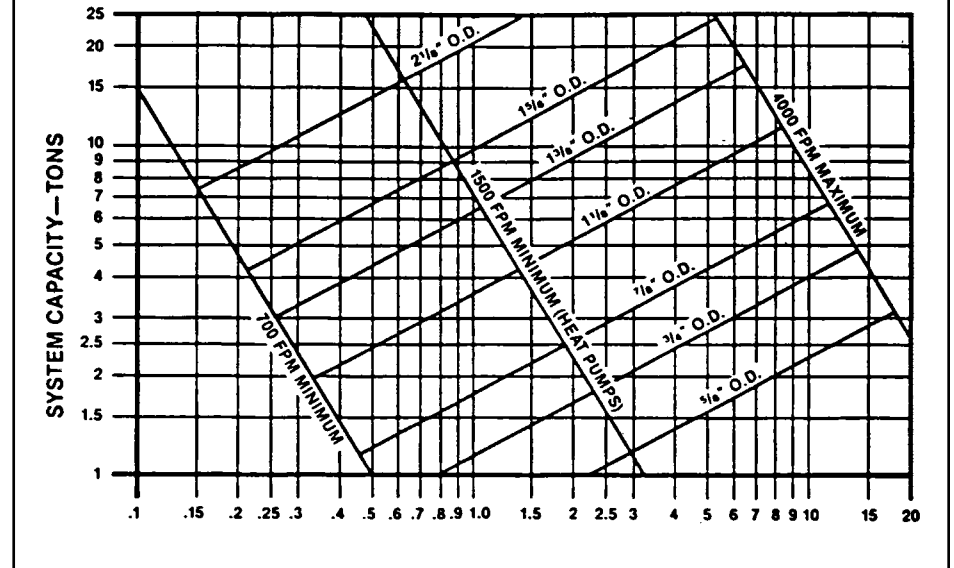

NOTES:

1. The minimum velocity line (700 fpm) is recommended for cooling only units with vertical or horizontal run refrigerant lines.
2. For suction pressure drop (PSIG), multiply percent (%) loss by 1.18.

B. TYPICAL PIPING RECOMMENDATIONS

REFRIGERANT PIPING:

The following will be of help in accomplishing a successful installation.

1. Size liquid line for no more than 10°F loss which corresponds to approximately 50 PSIG pressure drop.
2. Size suction lines for no more than 2°F loss which corresponds to approximately 5 PSIG pressure drop.
3. Install sight glass, filter drier and solenoid valve in liquid line adjacent to evaporator. Filter drier should be between the condensing unit and sight glass.
4. Pitch all horizontal suction lines downward in the direction of flow. (1/2" to 10 ft. run)

5. When making up refrigerant piping, take every precaution to prevent dirt and moisture from entering the piping.
6. Locate the condensing unit and evaporator(s) as close together as possible to minimize piping runs.
7. Liquid or suction lifts not to exceed 60 ft.

TABLE 3

RECOMMENDED VAPOR AND LIQUID LINE SIZES FOR VARIOUS LENGTHS OF RUN

EQUIVALENT LENGTH TO EVAPORATOR (FEET)	LIQUID LINE O.D. SIZES (INCHES)		VAPOR LINE O.D. SIZES (INCHES)	
	079	091	079	091
0' to 15'	1/2	1/2	1-1/8	1-1/8
16' to 50'	1/2	1/2	1-1/8	1-1/8
51' to 100'	1/2	1/2	1-1/8	1-3/8
101' to 150'	1/2	1/2	1-3/8	1-3/8

NOTE: Runs between condenser and evaporator not to exceed 150' linear equivalent length

FIGURE 5
COIL BELOW CONDENSING UNIT

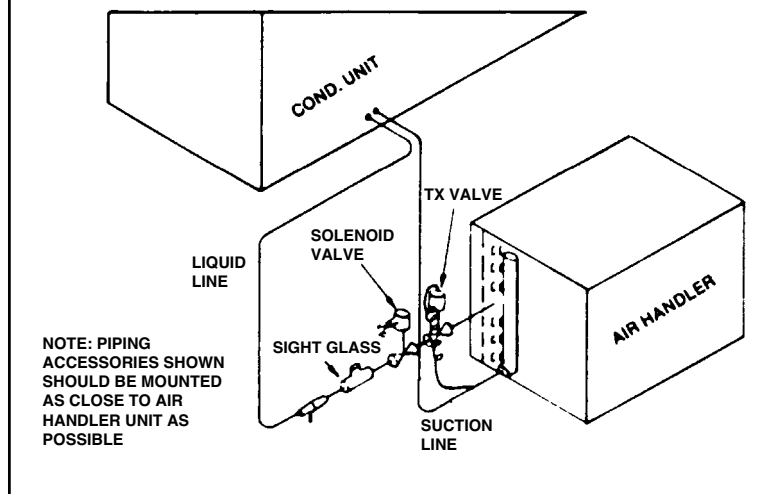
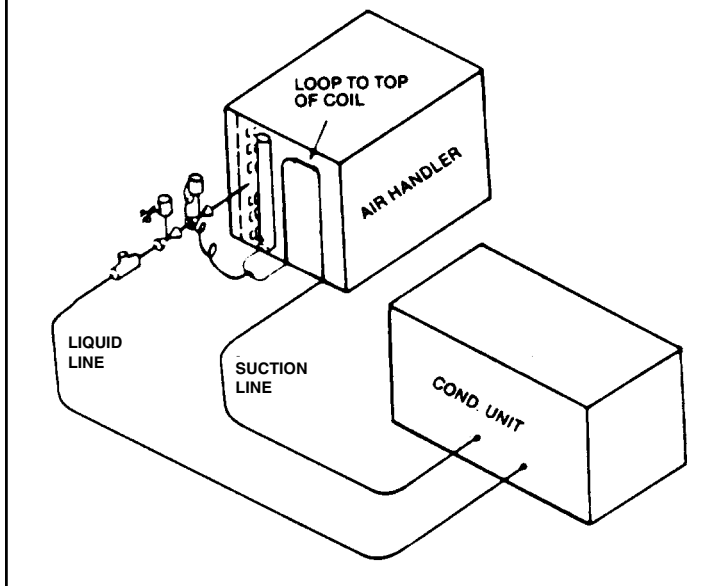

FIGURE 6
COIL ABOVE CONDENSING UNIT



VIX. WIRING

NOTE: Field wiring must comply with the National Electric Code (CEC in Canada) and any local ordinance that may apply.

X. ELECTRICAL POWER

It is important that proper electrical power is available at the unit. Voltage must not vary more than 10% of that stamped on the rating plate. (See Electrical Data Table for minimum and maximum voltage.) Interphase voltage variation on three-phase units must not be more than 3%. Contact local power company for correction of improper voltage or phase unbalance.

IMPORTANT: Models equipped with scroll compressors must be phased correctly for proper compressor rotation. If the compressor is noisy or if suction and discharge pressures do not appear normal, reverse any two power leads to the unit. Extended run time in reverse rotation will damage the compressor and lead to premature failure.

XI. POWER WIRING

Power wiring must be run in grounded rain-tight conduit. Power wiring must comply with the National Electric Code (C.E.C. in Canada) and any applicable local code.

XII. WIRE ROUTING

POWER WIRING MUST BE RUN IN CONDUIT. Conduit must be run through the connector panel below the service cover and attached to the bottom of the control box.

If low (extra-low in Canada) voltage control wire is run in conduit with power supply, Class I insulation is required. If run separate, Class II is required. Low voltage wiring may be run through the insulated bushing provided in the 7/8 " hole in the connector panel then routed to the control box.

WARNING

AFTER COMPLETION OF WIRING CHECK ALL ELECTRICAL CONNECTIONS, INCLUDING FACTORY WIRING WITHIN THE UNIT, AND MAKE SURE ALL CONNECTIONS ARE TIGHT, REPLACE AND SECURE ALL ELECTRICAL BOX COVERS AND ACCESS DOORS BEFORE LEAVING UNIT OR TURNING ON POWER TO CIRCUIT SUPPLY UNIT. FAILURE TO DO SO CAN CAUSE A FIRE OR ELECTRICAL SHOCK RESULTING IN PROPERTY DAMAGE, PERSONAL INJURY OR DEATH.

WARNING

THIS UNIT MUST BE PERMANENTLY GROUNDED. A GROUND LUG IS PROVIDED NEAR THE CONTACTOR FOR A GROUND WIRE. FAILURE TO DO SO CAN CAUSE A FIRE OR ELECTRICAL SHOCK RESULTING IN PROPERTY DAMAGE, SEVERE PERSONAL INJURY OR DEATH.

XIII. GROUNDING

A grounding lug is provided in control box for a ground wire.

Grounding may be accomplished by grounding the power line conduit to the unit.

XIV. THERMOSTAT — 6½ AND 7½ TON

A single-stage cooling, two-stage heating (if heating is used) thermostat should be mounted on an inside wall about four to five feet above the floor in a location where it will not be affected by the sun or drafts, from open doors or other sources. Install, level, and after installation check the thermostat calibration and recalibrate if necessary.

XV. LEAK TESTING

Pressure line set and coil through service fittings with dry nitrogen to 150 psig maximum. Leak test all joints using liquid detergent. If a leak is found, recover pressure and repair.

XVI. R-410A REFRIGERANT

A. TOOLS REQUIRED FOR INSTALLING & SERVICING R-410A MODELS

Manifold Sets:

- Up to 800 PSIG High Side
- Up to 250 PSIG Low Side
- 550 PSIG Low Side Retard

Manifold Hoses:

- Service Pressure Rating of 800 PSIG

Recovery Cylinders:

- 400 PSIG Pressure Rating
- Dept. of Transportation 4BA400 or BW400

▲ CAUTION

R-410A systems operate at higher pressures than R-22 systems. Do not use R-22 service equipment or components on R-410A equipment.

B. SPECIFICATION OF R-410A:

Application: **R-410A is not a drop-in replacement for R-22;** equipment designs must accommodate its higher pressures. It cannot be retrofitted into R-22 condensing units.

Physical Properties: R-410A has an atmospheric boiling point of -62.9°F and its saturation pressure at 77°F is 224.5 psig.

Composition: R-410A is an azeotropic mixture of 50% by weight difluoromethane (HFC-32) and 50% by weight pentafluoroethane (HFC-125).

Pressure: The pressure of R-410A is approximately 60% (1.6 times) greater than R-22. Recovery and recycle equipment, pumps, hoses and the like need to have design pressure ratings appropriate for R-410A. *Manifold sets need to range up to 800 psig high-side and 250 psig low-side with a 550 psig low-side retard. Hoses need to have a service pressure rating of 800 psig. Recovery cylinders need to have a 400 psig service pressure rating. DOT 4BA400 or DOT BW400.*

Combustibility: At pressures above 1 atmosphere, mixture of R-410A and air can become combustible. **R-410A and air should never be mixed in tanks or supply lines, or be allowed to accumulate in storage tanks. Leak checking should never be done with a mixture of R-410A and air.** Leak checking can be performed safely with nitrogen or a mixture of R-410A and nitrogen.

C. QUICK REFERENCE GUIDE FOR R-410A

- R-410A refrigerant operates at approximately 60% higher pressure (1.6 times) than R-22. Ensure that servicing equipment is designed to operate with R-410A.
- R-410A refrigerant cylinders are pink in color.
- R-410A, as with other HFC's, is only compatible with POE oils.
- Vacuum pumps will not remove moisture from oil.
- R-410A systems are to be charged with liquid refrigerants. Prior to March 1999, R-410A refrigerant cylinders had a dip tube. These cylinders should be kept upright for equipment charging. Post March 1999 cylinders do not have a dip tube and should be inverted to ensure liquid charging of the equipment.
- Do not install a suction line filter drier in the liquid line.
- A liquid line filter drier is standard on every unit. Only manufacturer approved liquid line filter driers can be used. These filter driers are rated for minimum working pressure of 600 psig.
- Desiccant (drying agent) must be compatible for POE oils and R-410A.

D. REPLACEMENT UNITS

To prevent failure of a new condensing unit, the existing evaporator tubing system must be correctly sized and cleaned or replaced. Care must be exercised that the expansion device is not plugged. For new and replacement units, a liquid line filter drier should be installed and refrigerant tubing should be properly sized. Test the oil for acid. If positive, a suction line filter drier is mandatory.

IMPORTANT: WHEN REPLACING AN R-22 UNIT WITH AN R-410A UNIT, EITHER REPLACE THE LINE SET OR ENSURE THAT THE EXISTING LINE SET IS THOROUGHLY CLEANED OF ANY OLD OIL OR DEBRIS.

⚠ CAUTION

Only use evaporators approved for use on R-410A systems. Use of existing R-22 evaporators can introduce mineral oil to the R-410A refrigerant forming two different liquids and decreasing oil return to the compressor. This can result in compressor failure.

E. EVAPORATOR COIL

REFER TO EVAPORATOR COIL MANUFACTURER'S INSTALLATION INSTRUCTIONS:

IMPORTANT: The manufacturer is not responsible for the performance and operation of a mismatched system, or for a match listed with another manufacturer's coil.

XVII. EVACUATION AND CHARGING

The evacuation of any system component that has been exposed to atmosphere or lost its charge is essential before charging. Never attempt to operate a system while it is under a vacuum.

FIGURE 7
TYPICAL FIELD WIRING CONNECTIONS — 6½ AND 7½ TON

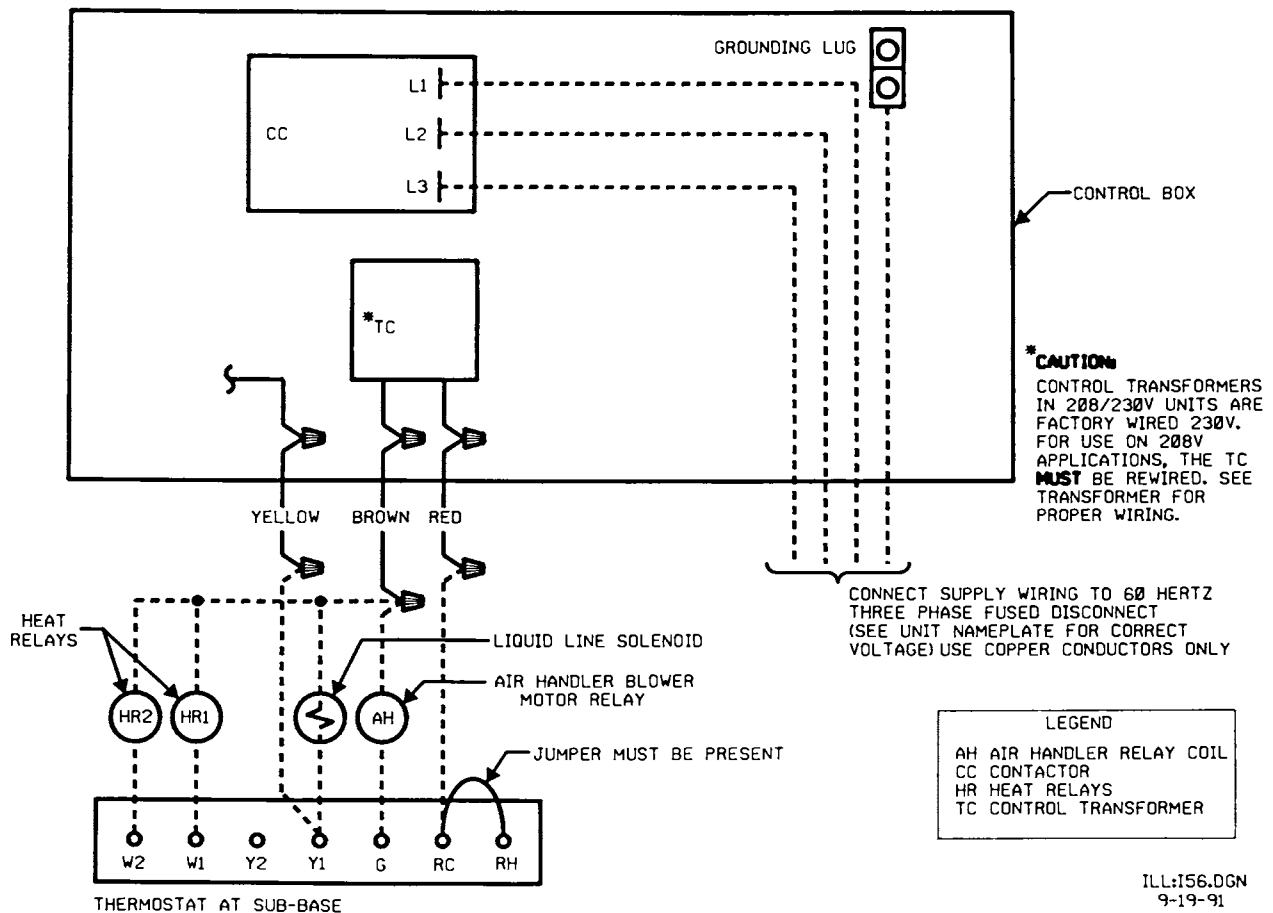

TABLE 4

FIELD WIRE SIZE FOR 24 VOLT THERMOSTAT CIRCUITS						
Thermostat Load - Amps	SOLID COPPER WIRE - AWG					
	3.0	16	14	12	10	10
2.5	16	14	12	12	10	10
2.0	18	16	14	12	12	10
	50	100	150	200	250	300
	Length of Run - Feet (1)					

(1) Wire length equals twice the run distance.

NOTE: The condensing unit is shipped with a holding charge of dry nitrogen which must be purged from the unit before evacuation.

1. Since the condensing unit itself must be evacuated, open the suction, discharge and liquid shut-off valves.
2. Use a refrigeration type vacuum pump capable of evacuation in the 500 micron range.
3. Connect the vacuum pump to the service manifold assembly with a pressure gauge that will read 30 inches vacuum. Connect the service manifold to the suction line schrader valve port.
4. With an accurate scale, ½ oz., set refrigerant tank up so its weight can be measured while in a position to charge liquid. (Unit must be off.) Energize liquid line solenoid valve by wiring valve to 24V power supply (or open by manual stem if applicable).
5. Connect to the liquid shut-off valve port. Shut off tank and evacuate the system. The pressure gauge should read at least 29.5" of vacuum.
6. Triple evacuate the system.
7. The refrigerant system will now be free of noncondensables.
8. Remove vacuum pump from 3-way valve.
9. Install refrigerant tank (liquid charging) to service valve.
10. Before tightening, purge tank and service valve hose.

CHARGING HINTS

SYMPTOM	POSSIBLE CAUSE	REMEDY
High head pressure	a. Air flow to or from condenser restricted or dirty condenser b. Faulty condenser fan or motor. c. Overcharge of refrigerant d. Air in system.	a. Remove obstruction, relocate condensing unit, if necessary clean condenser. b. Replace. c. Reduce charge. d. Evacuate and recharge.
Low head pressure	a. Short of refrigerant. b. Low evaporator air flow.	a. Check for leak, add charge. b. Increase blower speed, check filters.
Low vapor & hot compressor	a. Short of refrigerant.	a. Check for leak—add refrigerant.
Excessive sweating	a. Low indoor airflow b. Excess refrigerant	a. Increase speed of air handler blower or reduce restriction—replace air filter. b. Slowly reduce charge.

11. Note weight of refrigerant tank.
12. De-energize liquid line solenoid valve. Open refrigerant tank valve. Allow pressure in tank and unit to equalize.
13. Close off service valve to liquid port and note weight of refrigerant tank.
14. Position tank for gas charging.
15. Re-wire liquid line solenoid to thermostat control. Close main disconnect switch and turn thermostat to lowest setting.
16. Charge unit per chart.
17. Adjust refrigerant charge to obtain pressures indicated (refer to Table 5).

TABLE 5
REQUIRED OZS. R-410A PER FT. OF TUBING

Tube Size O.D., In.	Liquid oz/ft	Vapor oz/ft
1/2	1.06	0.04
5/8	1.65	0.07
3/4	2.46	0.10
7/8	3.28	0.13
1 1/8		0.22
1 3/8		0.34
1 5/8		0.48
2 1/8		0.84

Quantities based on 110°F liquid and 45°F vapor.

BASIC SYSTEM CHARGE*

Unit Model	Basic System Charge, Oz. [g] *
RAWL-079	219 [6209]
RAWL-091	400 [11,340]

*-System with 0 Feet [0] of tubing.

18. Note weight of refrigerant tank.
19. When system has stabilized, check superheat at the suction line service valve. The actual line temperature should be 8° to 20°F higher than the saturation temperature corresponding to the suction pressure. If superheat is measured at evaporator, the actual line temperature should be 6° to 10° higher than the saturation temperature corresponding to the suction pressure.
20. Close service ports on suction and liquid valves. Remove service gauges.
21. Replace service port caps and valve stem caps. These caps must be replaced to prevent leaks.
22. Record total charge quantity on rating plate.

XVIII. SEQUENCE OF OPERATION — 6½ AND 7½ TON

1. When the room temperature is higher than the thermostat setting, the thermostat contacts close and energize the compressor contactor (CC) through the high pressure, and low pressure controls. If the unit has “short cycled” and the optional time delay (TDC) has been supplied, the contactor coil (CC) will remain de-energized for up to five (5) minutes.
2. The system will continue cooling operation, as long as the contacts of all safety devices are closed and until the thermostat is satisfied.
3. When the thermostat is satisfied, compressor or contactor (CC) is de-energized.

XIX. ACCESSORIES

A. ANTI-SHORT CYCLE TIMER

ANTI-SHORT-CYCLE TIMER — Prevents restarting of unit for five minutes if shut down for any reason. (See wiring diagram and schematic in this manual for proper location and installation; item TDC.)

FIGURE 8
ANTI-SHORT CYCLE TIMER



NOTE: These units must be installed outdoors. No ductwork can be attached, or other modifications made, to the discharge grille. Modifications will affect performance or operation.

B. DISCHARGE PRESSURE CONTROL

Outdoor fan motor speed control designed to regulate condenser head pressure at low ambients by varying the air volume through the condenser. Has been tested and is available through the parts department.

C. LIQUID LINE SOLENOID VALVE

LIQUID LINE SOLENOID VALVE (24V) — Recommended for all split system applications, to prevent refrigerant migration during off cycles. See wiring connection (See Figure 10). Solenoid to be located in liquid line close to air handler.

FIGURE 9
LIQUID LINE SOLENOID VALVE



D. SIGHT GLASS

SIGHT GLASS — Allows viewing of the refrigerant. Bubbles may indicate a shortage of refrigerant or a restriction in the liquid line. The color indicator shows relative moisture saturation of the refrigerant. Its inclusion in the refrigerant piping is recommended. A minimum of 12 hours after installation is required before attempting to determine if a moisture condition within the system exists.

XX. MISCELLANEOUS

A. CHARGE CHARTS

FIGURE 10

RAWL-079 (R410A)

A/C SYSTEM CHARGE CHART

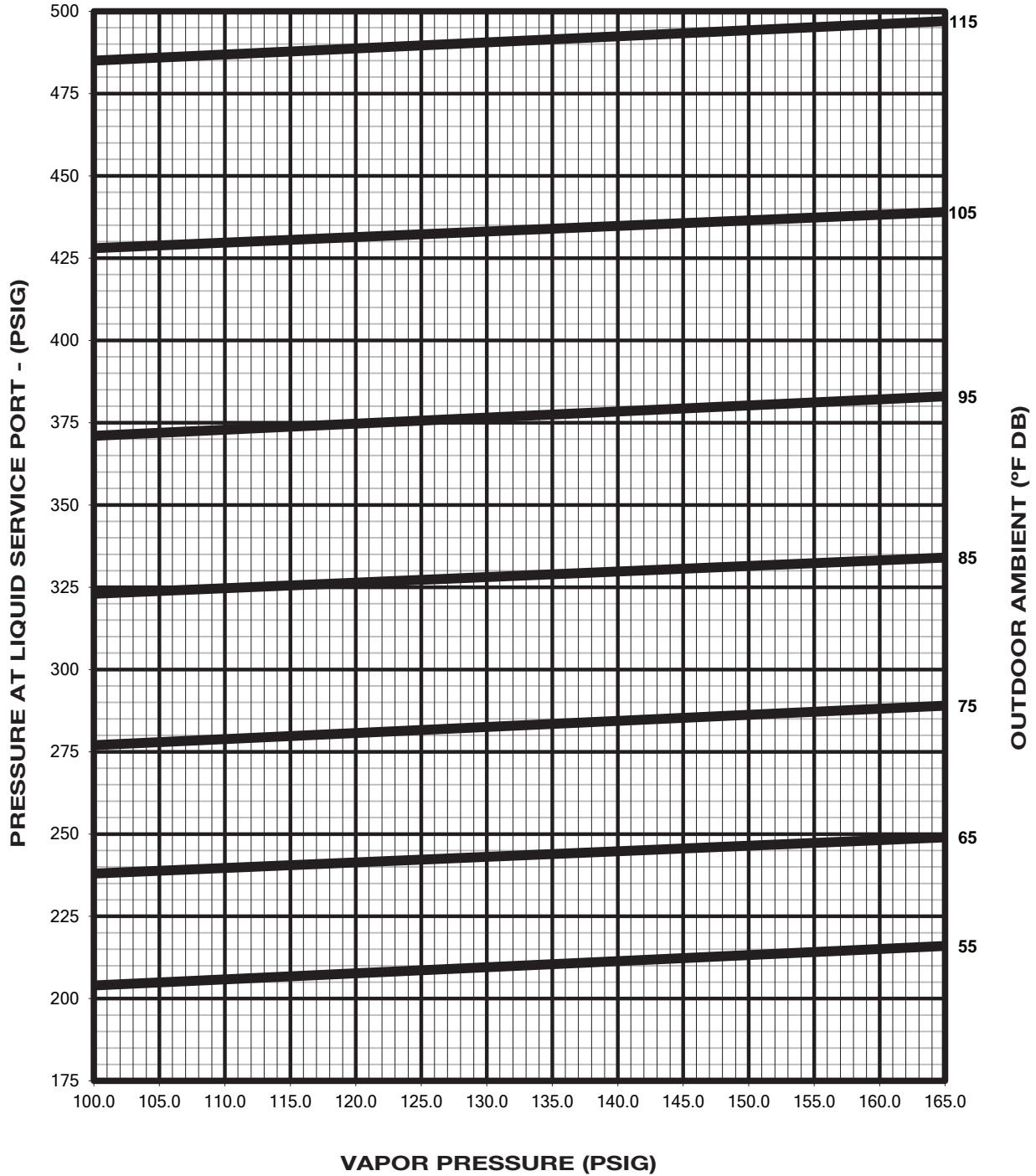

CAUTION: RETURN AIR TEMPERATURE MUST BE WITHIN COMFORT CONDITIONS BEFORE FINAL REFRIGERANT CHECK!

- INSTRUCTIONS: 1. MEASURE PRESSURE AT COMPRESSOR SUCTION AND LIQUID.
2. MEASURE OUTDOOR AMBIENT TO UNIT.
3. PLACE AN "X" ON THE CHART WHERE THE SUCTION AND LIQUID INTERSECT.
4. IF "X" IS BELOW OUTDOOR AMBIENT TEMPERATURE LINE, ADD CHARGE AND REPEAT STEPS 1-3.
5. IF "X" IS ABOVE AMBIENT TEMPERATURE LINE, RECOVER EXCESS CHARGE AND REPEAT STEPS 1-3.

92-102644-17-00



FIGURE 11

RAWL-091 (R410A)

A/C SYSTEM CHARGE CHART

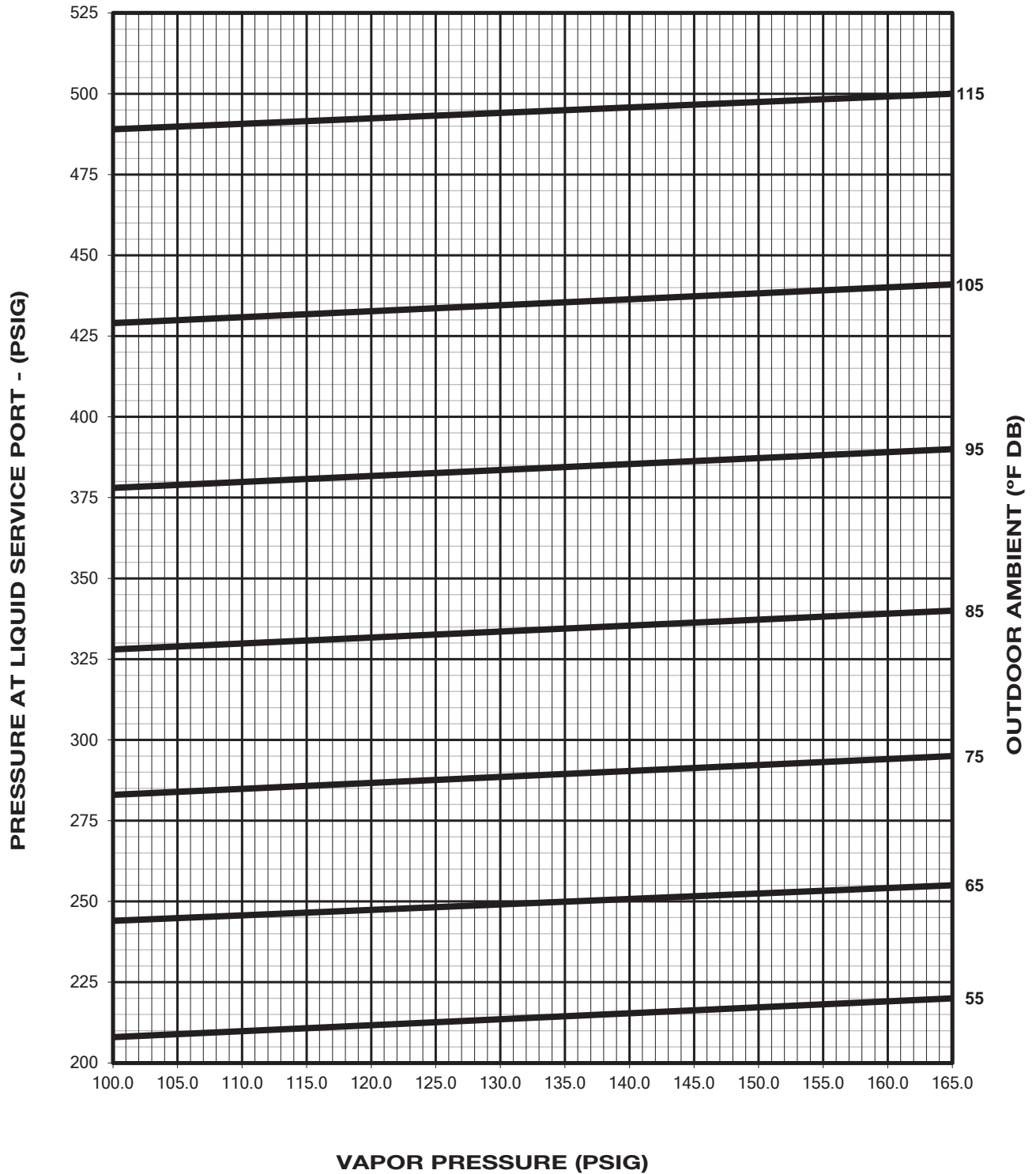

CAUTION: RETURN AIR TEMPERATURE MUST BE WITHIN COMFORT CONDITIONS BEFORE FINAL REFRIGERANT CHECK!

- INSTRUCTIONS: 1. MEASURE PRESSURE AT COMPRESSOR SUCTION AND LIQUID.
2. MEASURE OUTDOOR AMBIENT TO UNIT.
3. PLACE AN "X" ON THE CHART WHERE THE SUCTION AND LIQUID INTERSECT.
4. IF "X" IS BELOW OUTDOOR AMBIENT TEMPERATURE LINE, ADD CHARGE AND REPEAT STEPS 1-3.
5. IF "X" IS ABOVE AMBIENT TEMPERATURE LINE, RECOVER EXCESS CHARGE AND REPEAT STEPS 1-3.

92-102644-18-00



B. MAINTENANCE AND OPERATION

1. All access panels must be in place when unit is in operation.
2. For maximum efficiency, the condenser coil must be kept clean. Periodic inspections, depending on local conditions are recommended. If it is necessary to clean the condenser coil, use a common garden hose.
3. Never operate the unit without filters installed in the air handler.
4. If a compressor crankcase heater is used, it must be turned on 12 hours prior to starting the compressor.

1. CONTACTOR

The contactor is an electrical switch which operates the compressor and condenser fans. Its 24 volt coil is activated either directly or indirectly by the room thermostat.

2. HIGH PRESSURE SWITCH (HPC)

Opens the contactor (24 volt) circuit on high refrigerant pressure—Manual Reset—check for cause of tripping before putting unit back in service.

3. LOW PRESSURE SWITCH (LPC)

Acts as safety against loss of refrigerant and low evaporator temperatures.

4. PRE-START CHECK

PRE-START CHECK

1. Is condensing unit properly located and level?
2. Is air free to travel to and from condensing unit?
3. Is the wiring correct and according to the unit wiring diagram?
4. Are wiring connections tight? (Including those in unit and compressor electrical box.)
5. Is the unit properly grounded?
6. Is circulating air blower correctly wired?
7. Is condensing unit properly fused?
8. Is the thermostat level, correctly wired and in a good location?
9. Is the ductwork correctly sized, run, taped and insulated?
10. Is refrigerant tubing neatly run and suction line thoroughly insulated?
11. Is condensate drain line properly sized, run, trapped and pitched?
12. Are refrigerant connections tight and leak tested?
13. Is filter clean and in place?
14. Does the condenser fan turn free without rubbing?
15. Is the fan tight on the fan shaft?
16. Are all covers and access panels in place to prevent air loss?
17. Are refrigerant valves open for full flow?

C. TROUBLESHOOTING

▲ WARNING

DISCONNECT ALL POWER TO UNIT BEFORE SERVICING. CONTACTOR MAY BREAK ONLY ONE SIDE. FAILURE TO SHUT OFF POWER CAN CAUSE ELECTRICAL SHOCK RESULTING IN PERSONAL INJURY OR DEATH.

SYMPTOM	POSSIBLE CAUSE	REMEDY
Unit will not run	<ul style="list-style-type: none"> Power off or loose electrical connection Thermostat out of calibration-set too high Defective contactor Blown fuses Transformer defective High pressure control open (if provided) Interconnecting low voltage wiring damaged. 	<ul style="list-style-type: none"> Check for correct voltage at compressor contactor in control box Reset Check for 24 volts at contactor coil - replace if contacts are open Replace fuses Check wiring-replace transformer Reset-also see high head pressure remedy-The high pressure control opens at 610 PSIG Replace thermostat wiring
Condenser fan runs, compressor doesn't	<ul style="list-style-type: none"> Run or start capacitor defective (single phase only) Start relay defective (single phase only) Loose connection Compressor stuck, grounded or open motor winding, open internal overload. Low voltage condition 	<ul style="list-style-type: none"> Replace Replace Check for correct voltage at compressor - check & tighten all connections Wait at least 2 hours for overload to reset. If still open, replace the compressor. At compressor terminals, voltage must be within 10% of rating plate volts when unit is operating. Add start kit components
Insufficient cooling	<ul style="list-style-type: none"> Improperly sized unit Improper airflow Incorrect refrigerant charge Air, non-condensibles or moisture in system Incorrect voltage 	<ul style="list-style-type: none"> Recalculate load Check - should be approximately 400 CFM per ton. Charge per procedure attached to unit service panel Recover refrigerant, evacuate & recharge, add filter drier At compressor terminals, voltage must be within 10% of rating plate volts when unit is operating.
Compressor short cycles	<ul style="list-style-type: none"> Incorrect voltage Defective overload protector Refrigerant undercharge 	<ul style="list-style-type: none"> At compressor terminals, voltage must be $\pm 10\%$ of nameplate marking when unit is operating. Replace - check for correct voltage Add refrigerant
Registers sweat	<ul style="list-style-type: none"> Low evaporator airflow 	<ul style="list-style-type: none"> Increase speed of blower or reduce restriction - replace air filter
High head-low vapor pressures	<ul style="list-style-type: none"> Restriction in liquid line, expansion device or filter drier Flow check piston size too small Incorrect capillary tubes TXV does not open 	<ul style="list-style-type: none"> Remove or replace defective component Change to correct size piston Change coil assembly Replace TXV
High head-high or normal vapor pressure - Cooling mode	<ul style="list-style-type: none"> Dirty condenser coil Refrigerant overcharge Outdoor fan not running Air or non-condensibles in system 	<ul style="list-style-type: none"> Clean coil Correct system charge Repair or replace Recover refrigerant, evacuate & recharge
High head-high or normal vapor pressure - Heating mode	<ul style="list-style-type: none"> Low air flow - condenser coil Refrigerant overcharge Air or non-condensibles in system Dirty condenser coil 	<ul style="list-style-type: none"> Check filters - correct to speed Correct system charge Recover refrigerant, evacuate & recharge Check filter - clean coil
Low head-high vapor pressures	<ul style="list-style-type: none"> Defective Compressor valves Defective TXV(s) 	<ul style="list-style-type: none"> Replace compressor Replace coil assembly
Low vapor - cool compressor - iced evaporator coil	<ul style="list-style-type: none"> Low evaporator airflow Operating below 65°F outdoors Moisture in system 	<ul style="list-style-type: none"> Increase speed of blower or reduce restriction - replace air filter Add Low Ambient Kit Recover refrigerant - evacuate & recharge - add filter drier
High vapor pressure	<ul style="list-style-type: none"> Excessive load Defective compressor 	<ul style="list-style-type: none"> Recheck load calculation Replace
Fluctuating head & vapor pressure	<ul style="list-style-type: none"> TXV hunting Air or non-condensibles in system 	<ul style="list-style-type: none"> Check TXV bulb clamp - check air distribution on coil - replace TXV Recover refrigerant, evacuate & recharge
Gurgle or pulsing noise at expansion device or liquid line	<ul style="list-style-type: none"> Air or non-condensibles in system 	<ul style="list-style-type: none"> Recover refrigerant, evacuate & recharge

FIGURE 12
WIRING DIAGRAM & SCHEMATIC

