

INSTALLATION INSTRUCTIONS

AIR-COOLED CONDENSING UNITS

(-)ANL-*AZ MODEL SERIES – 13 SEER

(-)APL-JAZ MODEL SERIES – 14 SEER

(-)APM-JAZ MODEL SERIES – 14.5 SEER



RECOGNIZE THIS SYMBOL AS AN INDICATION OF IMPORTANT SAFETY INFORMATION!

▲ WARNING

THESE INSTRUCTIONS ARE INTENDED AS AN AID TO QUALIFIED, LICENSED SERVICE PERSONNEL FOR PROPER INSTALLATION, ADJUSTMENT AND OPERATION OF THIS UNIT. READ THESE INSTRUCTIONS THOROUGHLY BEFORE ATTEMPTING INSTALLATION OR OPERATION. FAILURE TO FOLLOW THESE INSTRUCTIONS MAY RESULT IN IMPROPER INSTALLATION, ADJUSTMENT, SERVICE OR MAINTENANCE POSSIBLY RESULTING IN FIRE, ELECTRICAL SHOCK, PROPERTY DAMAGE, PERSONAL INJURY OR DEATH.

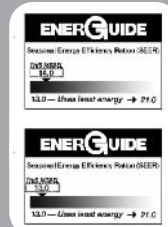

DO NOT DESTROY THIS MANUAL

PLEASE READ CAREFULLY AND KEEP IN A SAFE PLACE FOR FUTURE REFERENCE BY A SERVICEMAN

[] INDICATES METRIC CONVERSIONS

92-21354-51-08
SUPERSEDES 92-21354-51-07

TABLE OF CONTENTS

| | |
|---|-------|
| Checking Product Received | .2 |
| Dimensions | .3 |
| Electrical & Physical Data | .4 |
| General | .5 |
| Application | .5 |
| Corrosive Environment | .5 |
| Locating Unit | .6 |
| Unit Mounting | .7 |
| Factory-Preferred Tie-Down Method | .7 |
| Refrigerant Connections | .8 |
| Tools Required for Installing & Servicing R-410A Models | .8 |
| Specification of R-410A | .8 |
| Quick Reference for R-410A | .9 |
| Replacement Units | .9 |
| Evaporator Coil | .9 |
| Interconnecting Tubing | 10-13 |
| Evacuation Procedure | 14 |
| Start-Up and Performance | 14 |
| Checking Airflow | 14 |
| Checking Refrigerant Charge | 15 |
| Electrical Wiring | 16 |
| High and Low Pressure Controls (HPC or LPC) | 18 |
| Field Installed Accessories | 18 |
| Service | 19 |
| Trouble Shooting | 20-22 |
| Trouble Shooting Chart | 23 |
| Wiring Diagrams | 24-26 |

CHECKING PRODUCT RECEIVED

Upon receiving unit, inspect it for any shipping damage. Claims for damage, either apparent or concealed, should be filed immediately with the shipping company. Check condensing unit model number, electrical characteristics and accessories to determine if they are correct. Check system components (evaporator coil, condensing unit, evaporator blower, etc.) to make sure they are properly matched.

FIGURE 1
DIMENSIONS AND INSTALLATION CLEARANCES

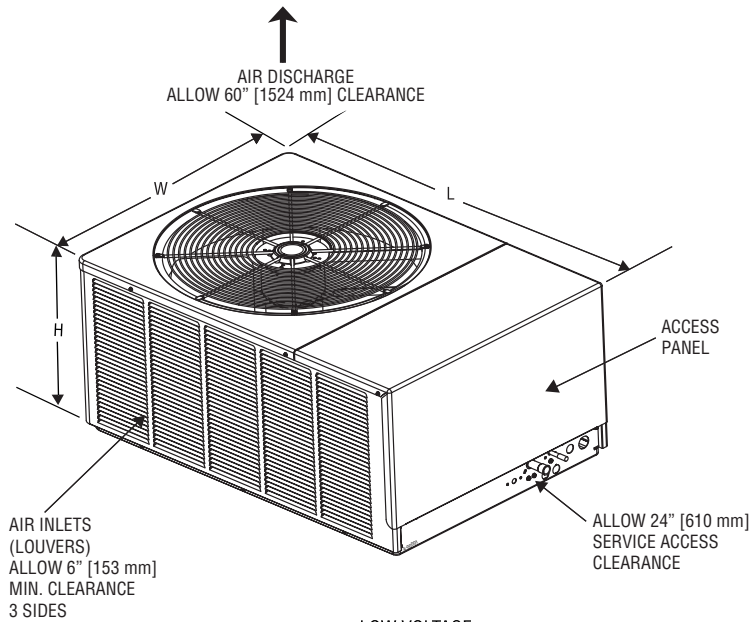

AIR INLETS (LOUVERS)
ALLOW 6" [153 mm]
MIN. CLEARANCE
3 SIDES

ACCESS PANEL

ALLOW 24" [610 mm]
SERVICE ACCESS
CLEARANCE

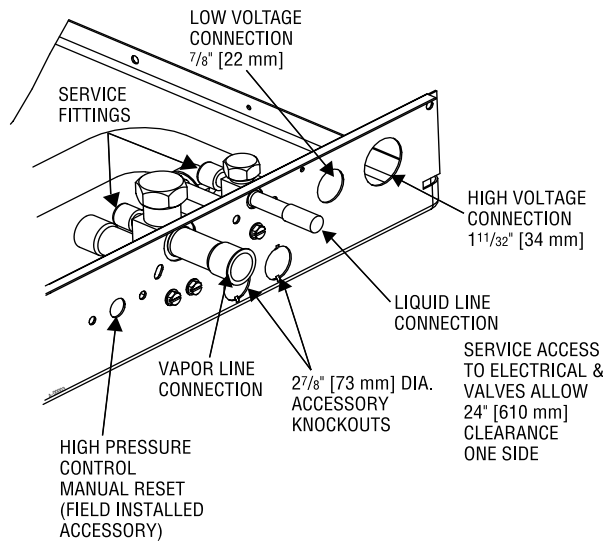

HIGH PRESSURE CONTROL
MANUAL RESET
(FIELD INSTALLED
ACCESSORY)

SERVICE ACCESS
TO ELECTRICAL &
VALVES ALLOW
24" [610 mm]
CLEARANCE
ONE SIDE

UNIT MODEL NUMBER EXPLANATION

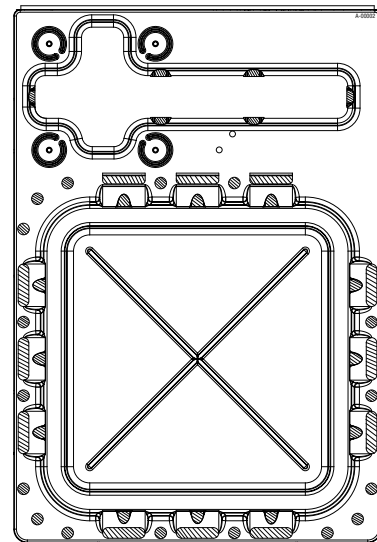
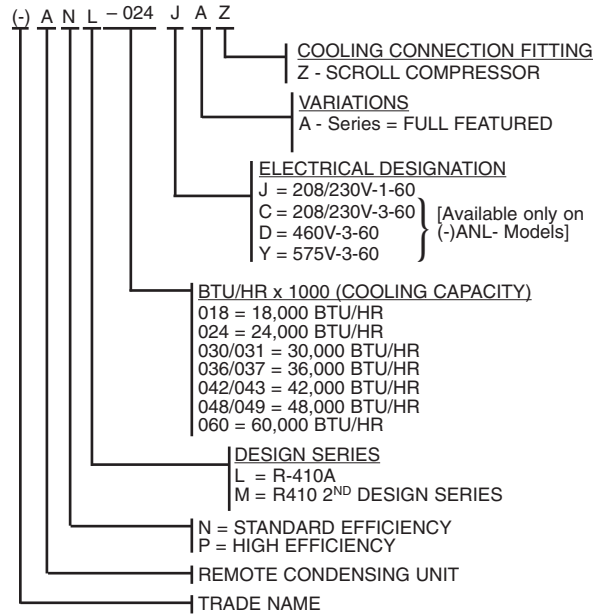

BOTTOM VIEW SHOWING DRAIN OPENINGS
(//// SHADED AREAS).

DIMENSIONAL DATA

| CONDENSING UNIT MODEL (-)ANL | 018 | 024/031 | 030 | 036/042 | 049 | 043/037 | 048/060 |
|------------------------------|----------------------------------|----------------------------------|----------------------------------|----------------------------------|----------------------------------|----------------------------------|----------------------------------|
| LENGTH "H" (INCHES) | 19" | 19" | 19" | 25" | 29" | 23" | 33" |
| LENGTH "L" (INCHES) | 35 ¹ / ₂ " | 40 ¹ / ₂ " | 44 ³ / ₈ " | 44 ³ / ₈ " | 44 ³ / ₈ " | 44 ³ / ₈ " | 44 ³ / ₈ " |
| WIDTH "W" (INCHES) | 24 ³ / ₄ " | 27 ⁵ / ₈ " | 31 ¹ / ₂ " | 31 ¹ / ₂ " | 31 ¹ / ₂ " | 31 ¹ / ₂ " | 31 ¹ / ₂ " |

| CONDENSING UNIT MODEL (-)APL | 018JAZ/024JAZ | 030JAZ | 036JAZ/042JAZ 048JAZ/060JAZ |
|------------------------------|----------------------------------|----------------------------------|----------------------------------|
| LENGTH "H" (INCHES) | 19" | 29" | 33" |
| LENGTH "L" (INCHES) | 40 ¹ / ₂ " | 44 ³ / ₈ " | 44 ³ / ₈ " |
| WIDTH "W" (INCHES) | 27 ⁵ / ₈ " | 31 ¹ / ₂ " | 31 ¹ / ₂ " |

| CONDENSING UNIT MODEL (-)APM | 018JAZ | 024JAZ 030JAZ | 036JAZ/042JAZ 048JAZ/060JAZ |
|------------------------------|----------------------------------|----------------------------------|----------------------------------|
| LENGTH "H" (INCHES) | 19" | 29" | 33" |
| LENGTH "L" (INCHES) | 40 ¹ / ₂ " | 44 ³ / ₈ " | 44 ³ / ₈ " |
| WIDTH "W" (INCHES) | 27 ⁵ / ₈ " | 31 ¹ / ₂ " | 31 ¹ / ₂ " |

TABLE 1
(-)ANL ELECTRICAL AND PHYSICAL DATA

| Model Number (-)ANL- | ELECTRICAL | | | | | | PHYSICAL | | | | | | |
|----------------------|---|--------------------------|----------------------------|-----------------------------------|----------------------------------|------------------------------|-----------------|------------------------|----------|-------------|-----------------------------|---------------|--------------------|
| | Phase Frequency (Hz) Voltage (Volts) | Compressor | | Fan Motor Full Load Amperes (FLA) | Minimum Circuit Ampacity Amperes | Fuse or HACR Circuit Breaker | | Outdoor Coil | | | Refrig. Per Circuit Oz. [g] | Weight | |
| | | Rated Load Amperes (RLA) | Locked Rotor Amperes (LRA) | | | Minimum Amperes | Maximum Amperes | Face Area Sq. Ft. [m²] | No. Rows | CFM [L/s] | | Net Lbs. [kg] | Shipping Lbs. [kg] |
| 018JAZ | 1-60-208/230 | 9/9 | 48 | 0.6 | 12/12 | 15/15 | 20/20 | 9.07 [0.84] | 1 | 1775 [838] | 70 [1984] | 130 [59] | 140 [63.5] |
| 024JAZ | 1-60-208/230 | 12.8/12.8 | 58.3 | 0.6 | 17/17 | 20/20 | 25/25 | 11 [1.02] | 1 | 1920 [906] | 72 [2041] | 140 [63.5] | 150 [68] |
| 030JAZ | 1-60-208/230 | 14.1/14.1 | 73 | 0.8 | 19/19 | 25/25 | 30/30 | 12.94 [1.2] | 1 | 2470 [1166] | 94 [2665] | 160 [72.6] | 170 [77.1] |
| 031JAZ | 1-60-208/230 | 14.1/14.1 | 73 | 0.6 | 19/19 | 25/25 | 30/30 | 11.1 [1.02] | 1 | 1920 [906] | 83 [2353] | 142 [54] | 152 [70] |
| 036CAZ | 3-60-208-230 | 13.2/13.2 | 88 | 0.8 | 18/18 | 25/25 | 30/30 | 17.26 [1.6] | 1 | 2570 [1213] | 113 [3204] | 205 [93] | 215 [97.5] |
| 036DAZ | 3-60-460 | 6.0 | 44 | 0.4 | 8 | 15 | 15 | 17.26 [1.6] | 1 | 2570 [1213] | 113 [3204] | 205 [93] | 215 [97.5] |
| 036JAZ | 1-60-208/230 | 17.9/17.9 | 112 | 0.8 | 24/24 | 30/30 | 40/40 | 17.26 [1.6] | 1 | 2570 [1213] | 113 [3204] | 205 [93] | 215 [97.5] |
| 037CAZ | 3-60-208-230 | 13.2/13.2 | 88 | 1.2 | 18/18 | 25/25 | 30/30 | 16.1 [1.5] | 1 | 2300 [1085] | 106 [3005] | 160 [72] | 170 [77] |
| 037DAZ | 3-60-460 | 6.0 | 44 | 0.6 | 9 | 15 | 15 | 16.1 [1.5] | 1 | 2300 [1085] | 106 [3005] | 160 [72] | 170 [77] |
| 037JAZ | 1-60-208/230 | 17.9/17.9 | 112 | 1.2 | 24/24 | 30/30 | 40/40 | 16.1 [1.5] | 1 | 2300 [1085] | 106 [3005] | 160 [72] | 170 [77] |
| 042CAZ | 3-60-208-230 | 13.5/13.5 | 88 | 1.2 | 19/19 | 25/25 | 30/30 | 17.26 [1.6] | 1 | 3290 [1553] | 130 [3686] | 205 [93] | 215 [97.5] |
| 042DAZ | 3-60-460 | 6.0 | 44 | 0.6 | 9 | 15 | 15 | 17.26 [1.6] | 1 | 3290 [1553] | 130 [3686] | 205 [93] | 215 [97.5] |
| 042JAZ | 1-60-208/230 | 17.9/17.9 | 112 | 1.2 | 24/24 | 30/30 | 40/40 | 17.26 [1.6] | 1 | 3290 [1553] | 130 [3686] | 205 [93] | 215 [97.5] |
| 043CAZ | 3-60-208-230 | 13.5/13.5 | 83.1 | 1.2 | 19/19 | 25/25 | 30/30 | 17.26 [1.6] | 1 | 3200 [1510] | 115 [3260] | 205 [93] | 215 [97] |
| 043DAZ | 3-60-460 | 6.0 | 44 | 0.6 | 9 | 15 | 15 | 17.26 [1.6] | 1 | 3200 [1510] | 115 [3260] | 205 [93] | 215 [97] |
| 043JAZ | 1-60-208/230 | 19.9/19.9 | 109 | 1.2 | 27/27 | 35/35 | 45/45 | 17.26 [1.6] | 1 | 3200 [1510] | 115 [3260] | 205 [93] | 215 [97] |
| 048CAZ | 3-60-208-230 | 13.7/13.7 | 83.1 | 1.2 | 19/19 | 25/25 | 30/30 | 23.01 [2.14] | 1 | 3500 [1652] | 145 [4111] | 230 [104.3] | 240 [108.9] |
| 048DAZ | 3-60-460 | 6.2 | 41 | 0.6 | 9 | 15 | 15 | 23.01 [2.14] | 1 | 3500 [1652] | 145 [4111] | 230 [104.3] | 240 [108.9] |
| 048JAZ | 1-60-208/230 | 21.8/21.8 | 117 | 1.2 | 29/29 | 35/35 | 50/50 | 23.01 [2.14] | 1 | 3500 [1652] | 145 [4111] | 230 [104.3] | 240 [108.9] |
| 048YAZ | 3-60-575 | 4.8 | 33 | 0.5 | 7 | 15 | 15 | 23.01 [2.14] | 1 | 3500 [1652] | 145 [4111] | 230 [104.3] | 240 [108.9] |
| 049CAZ | 3-60-208-230 | 13.7/13.7 | 83.1 | 1.2 | 19/19 | 25/25 | 30/30 | 20.1 [1.8] | 1 | 3200 [1510] | 132 [3742] | 235 [106] | 245 [111] |
| 049DAZ | 3-60-460 | 6.2 | 41 | 0.6 | 9 | 15 | 15 | 20.1 [1.8] | 1 | 3200 [1510] | 132 [3742] | 235 [106] | 245 [111] |
| 049JAZ | 1-60-208/230 | 21.8/21.8 | 117 | 1.2 | 29/29 | 35/35 | 50/50 | 20.1 [1.8] | 1 | 3200 [1510] | 132 [3742] | 235 [106] | 245 [111] |
| 049YAZ | 3-60-575 | 4.8 | 33 | 0.5 | 7 | 15 | 15 | 20.1 [1.8] | 1 | 3200 [1510] | 132 [3742] | 235 [106] | 245 [111] |
| 060CAZ | 3-60-208-230 | 15.6/15.6 | 110 | 1.2 | 21/21 | 25/25 | 35/35 | 23.01 [2.14] | 1 | 3500 [1652] | 180 [5103] | 250 [113.4] | 260 [117.9] |
| 060DAZ | 3-60-460 | 7.8 | 52 | 0.6 | 11 | 15 | 15 | 23.01 [2.14] | 1 | 3500 [1652] | 180 [5103] | 250 [113.4] | 260 [117.9] |
| 060JAZ | 1-60-208/230 | 26.3/26.3 | 134 | 1.2 | 35/35 | 45/45 | 60/60 | 23.01 [2.14] | 1 | 3500 [1652] | 180 [5103] | 250 [113.4] | 260 [117.9] |
| 060YAZ | 3-60-575 | 5.8 | 38.9 | 0.5 | 8 | 15 | 15 | 23.01 [2.14] | 1 | 3500 [1652] | 180 [5103] | 250 [113.4] | 260 [117.9] |

TABLE 2
(-)APL ELECTRICAL AND PHYSICAL DATA

| Model Number (-)APL- | ELECTRICAL | | | | | | PHYSICAL | | | | | | |
|----------------------|---|--------------------------|----------------------------|-----------------------------------|----------------------------------|------------------------------|-----------------|------------------------|----------|-------------|-----------------------------|---------------|--------------------|
| | Phase Frequency (Hz) Voltage (Volts) | Compressor | | Fan Motor Full Load Amperes (FLA) | Minimum Circuit Ampacity Amperes | Fuse or HACR Circuit Breaker | | Outdoor Coil | | | Refrig. Per Circuit Oz. [g] | Weight | |
| | | Rated Load Amperes (RLA) | Locked Rotor Amperes (LRA) | | | Minimum Amperes | Maximum Amperes | Face Area Sq. Ft. [m²] | No. Rows | CFM [L/s] | | Net Lbs. [kg] | Shipping Lbs. [kg] |
| 018J*Z | 1-60-208/230 | 9/9 | 48 | 0.8 | 13/13 | 15/15 | 20/20 | 11 [1.02] | 1 | 1900 [897] | 79 [2240] | 140 [63.5] | 155 [70.3] |
| 024J*Z | 1-60-208/230 | 13.5/13.5 | 58.3 | 0.8 | 18/18 | 25/25 | 30/30 | 11 [1.02] | 1 | 2300 [1085] | 105 [2977] | 140 [63.5] | 187 [84.8] |
| 030J*Z | 1-60-208/230 | 12.8/12.8 | 64 | 1.2 | 18/18 | 25/25 | 30/30 | 20 [1.86] | 1 | 3200 [1510] | 135 [3827] | 200 [90.7] | 213 [96.6] |
| 036J*Z | 1-60-208/230 | 16.7/16.7 | 79 | 1.2 | 23/23 | 30/30 | 35/35 | 23.01 [2.14] | 1 | 3200 [1510] | 141 [3997] | 230 [104.3] | 228 [103.4] |
| 042J*Z | 1-60-208/230 | 17.9/17.9 | 112 | 1.2 | 24/24 | 30/30 | 40/40 | 23.01 [2.14] | 1 | 3200 [1510] | 152 [4309] | 230 [104.3] | 252 [114.3] |
| 048J*Z | 1-60-208/230 | 21.8/21.8 | 117 | 1.2 | 29/29 | 35/35 | 50/50 | 23.01 [2.14] | 1 | 3300 [1557] | 152 [4309] | 230 [104.3] | 253 [114.8] |
| 060J*Z | 1-60-208/230 | 26.4/26.4 | 134 | 1.2 | 35/35 | 45/45 | 60/60 | 44 [4.09] | 2 | 3100 [1463] | 286 [8108] | 280 [127] | 305 [138.3] |

TABLE 3
(-)APM ELECTRICAL AND PHYSICAL DATA

| Model Number (-)APM- | Phase Frequency (Hz) Voltage (Volts) | ELECTRICAL | | | | | | PHYSICAL | | | | | |
|----------------------|---|--------------------------|----------------------------|-----------------------------------|----------------------------------|------------------------------|-----------------|-------------------------------------|----------|-------------|---------------------------|---------------|--------------------|
| | | Compressor | | Fan Motor Full Load Amperes (FLA) | Minimum Circuit Ampacity Amperes | Fuse or HACR Circuit Breaker | | Outdoor Coil | | | Refr. Per Circuit Oz. [g] | Weight | |
| | | Rated Load Amperes (RLA) | Locked Rotor Amperes (LRA) | | | Minimum Amperes | Maximum Amperes | Face Area Sq. Ft. [m ²] | No. Rows | CFM [L/s] | | Net Lbs. [kg] | Shipping Lbs. [kg] |
| 018JAZ | 1-60-208/230 | 9/9 | 48 | 0.8 | 13/13 | 15/15 | 20/20 | 11 [1.02] | 1 | 2300 [1085] | 82 [2325] | 137[62.1] | 152 [68.9] |
| 024JAZ | 1-60-208/230 | 13.5/13.5 | 58.3 | 1.1 | 18/18 | 25/25 | 30/30 | 20 [1.86] | 1 | 3300 [1557] | 128 [3629] | 190 [86.2] | 205 [93] |
| 030JAZ | 1-60-208/230 | 12.8/12.8 | 64 | 0.8 | 17/17 | 25/25 | 25/25 | 20 [1.86] | 1 | 3300 [1557] | 129 [3657] | 200 [90.7] | 213 [96.6] |
| 036JAZ | 1-60-208/230 | 16/16 | 79 | 0.8 | 21/21 | 25/25 | 35/35 | 23.01 [2.14] | 1 | 3300 [1557] | 146 [4139] | 201 [91.2] | 223 [101.2] |
| 042JAZ | 1-60-208/230 | 17.9/17.9 | 112 | 2.8 | 26/26 | 30/30 | 40/40 | 23.01 [2.14] | 1 | 3300 [1557] | 152 [4309] | 224 [101.6] | 246 [111.6] |
| 048JAZ | 1-60-208/230 | 21.8/21.8 | 117 | 2.8 | 31/31 | 40/40 | 50/50 | 23.01 [2.14] | 2 | 3300 [1557] | 203 [5755] | 265 [120.2] | 290 [131.5] |
| 060JAZ | 1-60-208/230 | 26.4/26.4 | 134 | 2.8 | 36/36 | 45/45 | 60/60 | 23 [2.14] | 2 | 3300 [1557] | 262 [7428] | 274 [124.3] | 299 [135.6] |

WARNING

THE MANUFACTURER'S WARRANTY DOES NOT COVER ANY DAMAGE OR DEFECT TO THE AIR CONDITIONER CAUSED BY THE ATTACHMENT OR USE OF ANY COMPONENTS, ACCESSORIES OR DEVICES (OTHER THAN THOSE AUTHORIZED BY THE MANUFACTURER) INTO, ONTO OR IN CONJUNCTION WITH THE AIR CONDITIONER. YOU SHOULD BE AWARE THAT THE USE OF UNAUTHORIZED COMPONENTS, ACCESSORIES OR DEVICES MAY ADVERSELY AFFECT THE OPERATION OF THE AIR CONDITIONER AND MAY ALSO ENDANGER LIFE AND PROPERTY. THE MANUFACTURER DISCLAIMS ANY RESPONSIBILITY FOR SUCH LOSS OR INJURY RESULTING FROM THE USE OF SUCH UNAUTHORIZED COMPONENTS, ACCESSORIES OR DEVICES.

MATCH ALL COMPONENTS:

- OUTDOOR UNIT
- INDOOR COIL/METERING DEVICE
- INDOOR AIR HANDLER/FURNACE
- REFRIGERANT LINES

GENERAL

The information contained in this manual has been prepared to assist in the proper installation, operation and maintenance of the air conditioning system. Improper installation, or installation not made in accordance with these instructions, can result in unsatisfactory operation and/or dangerous conditions, and can cause the related warranty not to apply.

Read this manual and any instructions packaged with separate equipment required to make up the system prior to installation. Retain this manual for future reference.

To achieve optimum efficiency and capacity, the indoor cooling coils listed in the condensing unit specification sheet should be used.

APPLICATION

Before installing any air conditioning equipment, a duct analysis of the structure and a heat gain calculation must be made. A heat gain calculation begins by measuring all external surfaces and openings that gain heat from the surrounding air and quantifying that heat gain. A heat gain calculation also calculates the extra heat load caused by sunlight and by humidity removal.

There are several factors that the installers must consider:

- Outdoor unit location
- System refrigerant charge
- Indoor unit blower speed
- System air balancing
- Proper equipment evacuation
- Indoor unit airflow
- Supply and return air duct design and sizing
- Diffuser and return air grille location and sizing

CORROSIVE ENVIRONMENT

The metal parts of this unit may be subject to rust or deterioration if exposed to a corrosive environment. This oxidation could shorten the equipment's useful life. Corrosive elements include, but are not limited to, salt spray, fog or mist in seacoast areas, sulphur or chlorine from lawn watering systems, and various chemical contaminants from industries such as paper mills and petroleum refineries.

If the unit is to be installed in an area where contaminants are likely to be a problem, special attention should be given to the equipment location and exposure.

- Avoid having lawn sprinkler heads spray directly on the unit cabinet.
- In coastal areas, locate the unit on the side of the building away from the waterfront.
- Shielding provided by a fence or shrubs may give some protection, but cannot violate minimum airflow and service access clearances.
- Elevating the unit off its slab or base enough to allow air circulation will help avoid holding water against the basepan.

Regular maintenance will reduce the build-up of contaminants and help to protect the unit's finish.

WARNING

DISCONNECT ALL POWER TO UNIT BEFORE STARTING MAINTENANCE. FAILURE TO DO SO CAN CAUSE ELECTRICAL SHOCK RESULTING IN SEVERE PERSONAL INJURY OR DEATH.

- Frequent washing of the cabinet, fan blade and coil with fresh water will remove most of the salt or other contaminants that build up on the unit.
- Regular cleaning and waxing of the cabinet with an automobile polish will provide some protection.
- A liquid cleaner may be used several times a year to remove matter that will not wash off with water.

Several different types of protective coatings are offered in some areas. These coatings may provide some benefit, but the effectiveness of such coating materials cannot be verified by the equipment manufacturer.

LOCATING UNIT

CONDENSER LOCATION

Consult local and national building codes and ordinances for special installation requirements. Following location information will provide longer life and simplified servicing of the outdoor condenser.

NOTE: These units must be installed outdoors. No ductwork can be attached, or other modifications made, to the discharge grille. Modifications will affect performance or operation.

OPERATIONAL ISSUES

- **IMPORTANT:** Locate the condenser in a manner that will not prevent, impair or compromise the performance of other equipment horizontally installed in proximity to the unit. Maintain all required minimum distances to gas and electric meters, dryer vents, exhaust and inlet openings. In the absence of National Codes, or manufacturers' recommendations, local code recommendations and requirements will take precedence.
- Refrigerant piping and wiring should be properly sized and kept as short as possible to avoid capacity losses and increased operating costs.
- Locate the condenser where water run off will not create a problem with the equipment. Position the unit away from the drip edge of the roof whenever possible. Units are weatherized, but can be affected by the following:
 - o Water pouring into the unit from the junction of rooflines, without protective guttering. Large volumes of water entering the condenser while in operation can impact fan blade or motor life, and coil damage may occur to a heat pump if moisture cannot drain from the unit under freezing conditions.
- Closely follow clearance recommendations on Page 3.
 - o 24" to the service panel access
 - o 60" above condenser fan discharge (unit top) to prevent recirculation
 - o 6" to condenser coil grille air inlets (per condenser).

FOR CONDENSERS WITH SPACE LIMITATIONS

In the event that a space limitation exists, we will permit the following clearances:

Single Unit Applications: Clearances below 6 inches will reduce unit capacity and efficiency. Do not reduce the 60-inch discharge, or the 24-inch service clearances.

Multiple Unit Applications: When multiple condenser grille sides are aligned, a 6-inch per unit clearance is recommended, for a total of 12" between two units. Two combined clearances below 12 inches will reduce capacity and efficiency. Do not reduce the 60-inch discharge, or 24-inch service, clearances.

- Do not obstruct the bottom drain opening in the condenser base pan. It is essential to provide defrost condensate drainage to prevent possible refreezing of the condensation. Provide a base pad for mounting the unit, which is slightly pitched away from the structure. Route condensate off the base pad to an area which will not become slippery and result in personal injury.

CUSTOMER SATISFACTION ISSUES

- The condenser should be located away from the living, sleeping and recreational spaces of the owner and those spaces on adjoining property.
- To prevent noise transmission, the mounting pad for the outdoor unit should not be connected to the structure, and should be located sufficient distance above grade to prevent ground water from entering the unit.

PROPER INSTALLATION

Proper sizing and installation of equipment is critical to achieve optimal performance. Use the information in this Installation Instruction Manual and reference the applicable Engineering Specification Sheet when installing this product.

IMPORTANT: This product has been designed and manufactured to meet ENERGY STAR® criteria for energy efficiency when matched with appropriate coil components. However, proper refrigerant charge and proper air flow are critical to achieve rated capacity and efficiency. Installation of this product should follow the manufacturer's refrigerant charging and air flow instructions. **Failure to confirm proper charge and airflow may reduce energy efficiency and shorten equipment life.**

UNIT MOUNTING

If elevating the condensing unit, either on a flat roof or on a slab, observe the following guidelines.

- The base pan provided elevates the condenser coil 3/4" above the base pad.
- If elevating a unit on a flat roof, use 4" x 4" (or equivalent) stringers positioned to distribute unit weight evenly and prevent noise and vibration.

NOTE: Do not block drain openings shown in Figure 1.

FACTORY-PREFERRED TIE-DOWN METHOD FOR CONDENSING UNITS

IMPORTANT: These instructions are intended as a guide to securing equipment for wind-load ratings of "120 MPH sustained wind load" and "3-second, 150 MPH gust." While this procedure is not mandatory, the Manufacturer does recommend that equipment be properly secured in areas where high wind damage may occur.

STEP 1: Before installing, clear pad of any dirt or debris.

IMPORTANT: The pad must be constructed of industry-approved materials, and must be thick enough to accommodate the concrete fastener.

STEP 2: Center base pan on pad, ensuring it is level.

STEP 3: Using basepad as a guide, mark spots on concrete where 4 holes will be drilled (see Figure 2).

TABLE 4
DIMENSIONS

| MODEL NUMBER | L | W | A | B | C | D |
|---|----------------------------------|------------------------------------|-----|-----|---------------------------------|----------------------------------|
| (-)ANL-018/024/030, (-)APL-018/024, (-)ANL-031, (-)APM-018 | 37 ⁵ / ₈ " | 25 ¹⁵ / ₁₆ " | 15" | 34" | 3 ¹ / ₂ " | 22 ¹ / ₂ " |
| (-)ANL-037/043/049, (-)ANL-036/042/048/060, (-)APL-030/036/042/048/060, (-)APM-024/030/036/042/048/060 | 41 ¹ / ₂ " | 29 ¹³ / ₁₆ " | 15" | 38" | 3 ¹ / ₂ " | 26 ¹ / ₂ " |

STEP 4: Drill four pilot holes in pad, ensuring that the hole is at least 1/4" deeper than the concrete screw being used.

STEP 5: Center basepan over pre-drilled holes and insert concrete screws.

STEP 6: Tighten concrete screws.

NOTE: Do not over-tighten the concrete screws. Doing so can weaken the integrity of the concrete screw and cause it to break.

STEP 7: Finish unit assembly per unit's installation instructions.

FIGURE 2
SCREW LOCATIONS

(4) 1/4" CONCRETE SCREWS SNUG TO BASE PAN. LENGTH TO PENETRATE CONCRETE 1.5" MINIMUM. SCREWS HAVE TO BE PLACED ON THE BASE PAN AS SHOWN

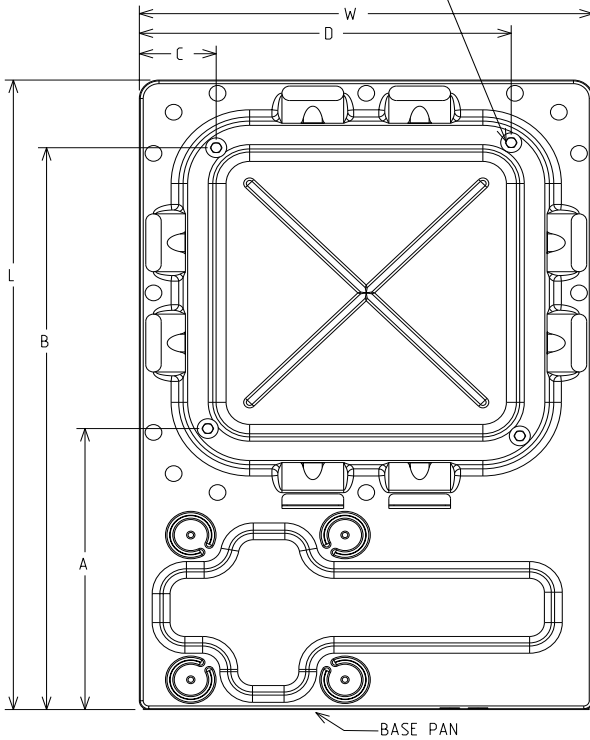

REFRIGERANT CONNECTIONS

All units are factory charged with Refrigerant 410A. All models are supplied with service valves. Keep tube ends sealed until connection is to be made to prevent system contamination.

TOOLS REQUIRED FOR INSTALLING & SERVICING R-410A MODELS

Manifold Sets:

- Up to 800 PSIG High side
- Up to 250 PSIG Low Side
- 550 PSIG Low Side Retard

Manifold Hoses:

- Service Pressure Rating of 800 PSIG

Recovery Cylinders:

- 400 PSIG Pressure Rating
- Dept. of Transportation 4BA400 or BW400

▲ CAUTION

R-410A systems operate at higher pressures than R-22 systems. Do not use R-22 service equipment or components on R-410A equipment.

SPECIFICATION OF R-410A:

Application: R-410A is not a drop-in replacement for R-22; equipment designs must accommodate its higher pressures. It cannot be retrofitted into R-22 condensing units.

Physical Properties: R-410A has an atmospheric boiling point of -62.9°F and its saturation pressure at 77°F is 224.5 psig.

Composition: R-410A is an azeotropic mixture of 50% by weight difluoromethane (HFC-32) and 50% by weight pentafluoroethane (HFC-125).

Pressure: The pressure of R-410A is approximately 60% (1.6 times) greater than R-22. Recovery and recycle equipment, pumps, hoses and the like need to have design pressure ratings appropriate for R-410A. *Manifold sets need to range up to 800 psig high-side and 250 psig low-side with a 550 psig low-side retard. Hoses need to have a service pressure rating of 800 psig. Recovery cylinders need to have a 400 psig service pressure rating. DOT 4BA400 or DOT BW400.*

Combustibility: At pressures above 1 atmosphere, mixture of R-410A and air can become combustible. **R-410A and air should never be mixed in tanks or supply lines, or be allowed to accumulate in storage tanks. Leak checking should never be done with a mixture of R-410A and air.** Leak checking can be performed safely with nitrogen or a mixture of R-410A and nitrogen.

QUICK REFERENCE GUIDE FOR R-410A

- R-410A refrigerant operates at approximately 60% higher pressure (1.6 times) than R-22. Ensure that servicing equipment is designed to operate with R-410A.
- R-410A refrigerant cylinders are pink in color.
- R-410A, as with other HFC's is only compatible with POE oils.
- Vacuum pumps will not remove moisture from oil.
- R-410A systems are to be charged with liquid refrigerants. Prior to March 1999, R-410A refrigerant cylinders had a dip tube. These cylinders should be kept upright for equipment charging. Post March 1999 cylinders do not have a dip tube and should be inverted to ensure liquid charging of the equipment.
- Do not install a suction line filter drier in the liquid line.
- A liquid line filter drier is standard on every unit. Only manufacturer approved liquid line filter driers can be used. These are Sporlan (CW083S) and Alco (80K083S) driers. These filter driers are rated for minimum working pressure of 600 psig.
- Desiccant (drying agent) must be compatible for POE oils and R-410A.

REPLACEMENT UNITS

To prevent failure of a new condensing unit, the existing evaporator tubing system must be correctly sized and cleaned or replaced. Care must be exercised that the expansion device is not plugged. For new and replacement units, a liquid line filter drier should be installed and refrigerant tubing should be properly sized. Test the oil for acid. If positive, a suction line filter drier is mandatory.

IMPORTANT: WHEN REPLACING AN R-22 UNIT WITH AN R-410A UNIT, EITHER REPLACE THE LINE SET OR ENSURE THAT THE EXISTING LINE SET IS THOROUGHLY CLEANED OF ANY OLD OIL OR DEBRIS.

EVAPORATOR COIL

REFER TO EVAPORATOR COIL MANUFACTURER'S INSTALLATION INSTRUCTIONS.

IMPORTANT: The manufacturer is not responsible for the performance and operation of a mismatched system, or for a match listed with another manufacturer's coil.

CAUTION

Only use evaporators approved for use on R-410A systems. Use of existing R-22 evaporators can introduce mineral oil to the R-410A refrigerant forming two different liquids and decreasing oil return to the compressor. This can result in compressor failure.

NOTE: All (-)ANL, (-)APL & (-)APM units must be installed with a TEV Evaporator.

The thermostatic expansion valve is specifically designed to operate with R-410A. **DO NOT use an R-22 TEV or evaporator. The existing evaporator must be replaced with the factory specified TEV evaporator specifically designed for R-410A.**

LOCATION

Do not install the indoor evaporator coil in the return duct system of a gas or oil furnace. Provide a service inlet to the coil for inspection and cleaning. Keep the coil pitched toward the drain connection.

CAUTION

When coil is installed over a finished ceiling and/or living area, it is recommended that a secondary sheet metal condensate pan be constructed and installed under entire unit. Failure to do so can result in property damage.

INTERCONNECTING TUBING

VAPOR AND LIQUID LINES

Keep all lines sealed until connection is made.

Make connections at the indoor coil first.

Refer to Line Size Information in Tables 5 through 7 for correct size and multipliers to be used to determine capacity for various vapor line diameters and lengths of run. The losses due to the lines being exposed to outdoor conditions are not included.

The factory refrigeration charge in the outdoor unit is sufficient for 15 feet of interconnecting lines. The factory refrigeration charge in the outdoor unit is sufficient for the unit and 15 feet of standard size interconnecting liquid and vapor lines. For different lengths, adjust the charge as indicated below.

1/4" ± 0.2 oz. per foot

5/16" ± 0.3 oz. per foot

3/8" ± 0.5 oz. per foot

1/2" ± 1.0 oz. per foot

MAXIMUM LENGTH OF LINES

The maximum length of interconnecting line is 150 feet. Always use the shortest length possible with a minimum number of bends. Additional compressor oil is not required for any length up to 150 feet.

NOTE: Excessively long refrigerant lines cause loss of equipment capacity.

OUTDOOR UNIT INSTALLED ABOVE INDOOR COIL

Keep the vertical separation between coils to a minimum. However, the vertical distance can be as great as 120 feet with the condensing unit ABOVE the indoor coil. Use the following guidelines when installing the unit:

1. DO NOT exceed 120 feet maximum vertical separation.
2. DO NOT change the flow check piston sizes if the vertical separation does not exceed the values in Table 6.
3. Flow Check Piston Coil:
 - a. The vertical separation can be greater than the value in Table 6, but no more than 120 feet.
 - b. If the separation height exceeds the Table value, reduce the indoor coil flow check piston by two sizes plus one size for additional 10 feet beyond the Table value.
4. Expansion Valve Coil:
 - a. The vertical separation can be greater than the Table value, but no more than 120 feet.
 - b. No changes are required for expansion valve coils.

5. Capillary Tube Coil:
DO NOT exceed the Table values for vertical separation for capillary tube coils.
6. Always use the smallest liquid line size permitted to minimize the system charge.
7. Table 6 may be used for sizing horizontal runs.

OUTDOOR UNIT BELOW INDOOR COIL

Keep the vertical separation to a minimum. Use the following guidelines when installing the unit:

1. DO NOT exceed the vertical separations as indicated on Table 6.
2. Always use the smallest liquid line size permitted to minimize system charge.
3. No changes are required for either flow check piston coils or expansions coils.
4. Table 6 may be used for sizing horizontal runs.

TUBING INSTALLATION

Observe the following when installing correctly sized type “L” refrigerant tubing between the condensing unit and evaporator coil:

- If a portion of the liquid line passes through a hot area where liquid refrigerant can be heated to form vapor, insulating the liquid line is required.
- Use clean, dehydrated, sealed refrigeration grade tubing.
- Always keep tubing sealed until tubing is in place and connections are to be made.
- Blow out the liquid and vapor lines with dry nitrogen before connecting to the outdoor unit and indoor coil. Any debris in the line set will end up plugging the expansion device.
- As an added precaution, a high quality filter drier is standard on R-410A units.
- Do not allow the vapor line and liquid line to be in contact with each other. This causes an undesirable heat transfer resulting in capacity loss and increased power consumption. The vapor line must be insulated.
- If tubing has been cut, make sure ends are deburred while holding in a position to prevent chips from falling into tubing. Burrs such as those caused by tubing cutters can affect performance dramatically, particularly on small liquid line sizes.
- For best operation, keep tubing run as short as possible with a minimum number of elbows or bends.
- Locations where the tubing will be exposed to mechanical damage should be avoided. If it is necessary to use such locations, the copper tubing should be housed to prevent damage.
- If tubing is to be run underground, it must be run in a sealed watertight chase.
- Use care in routing tubing and do not kink or twist. Use a good tubing bender on the vapor line to prevent kinking.
- Route the tubing using temporary hangers, then straighten the tubing and install permanent hangers. Line must be adequately supported.
- The vapor line must be insulated to prevent dripping (sweating) and prevent performance losses. Armaflex and Rubatex are satisfactory insulations for this purpose. Use 1/2” minimum insulation thickness, additional insulation may be required for long runs.
- Check Table 5 for the correct vapor line size. check Table 6 for the correct liquid line size.

TABLE 5
SUCTION LINE LENGTH/SIZE AND CAPACITY MULTIPLIER

| Unit Size | | 1½ Ton | 2 Ton | 2½ Ton | 3 Ton | 3½ Ton | 4 Ton | 5 Ton |
|------------------------------|----------|---------|---------|---------|-----------|-----------|-----------|-----------|
| Suction Line Connection Size | | ¾" I.D. | ¾" I.D. | ¾" I.D. | 7/8" I.D. | 7/8" I.D. | 7/8" I.D. | 7/8" I.D. |
| Suction Line Run - Feet | | 5/8 | 5/8 | 5/8 | ¾ | ¾ | 7/8 | 7/8 |
| | | ¾* | ¾* | ¾* | 7/8* | 7/8* | 1 1/8* | 1 1/8* |
| | | — | — | 7/8 | — | — | — | — |
| 25' | Optional | 1.00 | 1.00 | 1.00 | 1.00 | 1.00 | 1.00 | 1.00 |
| | Standard | 1.00 | 1.00 | 1.00 | 1.00 | 1.00 | 1.00 | 1.00 |
| | Optional | — | — | 1.00 | — | — | — | — |
| 50' | Optional | 0.98 | 0.98 | 0.96 | 0.98 | 0.99 | 0.99 | 0.99 |
| | Standard | 0.99 | 0.99 | 0.98 | 0.99 | 0.99 | 0.99 | 0.99 |
| | Optional | — | — | 0.99 | — | — | — | — |
| 100' | Optional | 0.95 | 0.95 | 0.94 | 0.96 | 0.96 | 0.96 | 0.97 |
| | Standard | 0.96 | 0.96 | 0.96 | 0.97 | 0.98 | 0.98 | 0.98 |
| | Optional | — | — | 0.97 | — | — | — | — |
| 150' | Optional | 0.92 | 0.92 | 0.91 | 0.94 | 0.94 | 0.95 | 0.94 |
| | Standard | 0.93 | 0.94 | 0.93 | 0.95 | 0.96 | 0.96 | 0.97 |
| | Optional | — | — | 0.95 | — | — | — | — |

*Standard Line Size

Note: Using suction line larger than shown in chart will result in poor oil return and is not recommended.

TUBING CONNECTIONS

Indoor evaporator coils have only a holding charge of dry nitrogen. Keep all tube ends sealed until connections are to be made.

- Use type "L" copper refrigeration tubing. Braze the connections with the following alloys:
 - copper to copper - 5%
 - Silver alloy (no flux)
 - copper to steel or brass - 35%
 - silver alloy (with flux)
- Be certain both refrigerant shutoff valves at the outdoor unit are closed.
- Clean the inside of the fittings and outside of the tubing with steel wool or sand cloth before soldering. Always keep chips, steel wool, dirt, etc., out of the inside when cleaning.
- Assemble tubing part way into fitting. Apply flux all around the outside of the tubing and push tubing into stop. This procedure will keep the flux from getting inside the system.
- Remove the cap and schrader core from service port to protect seals from heat damage.
- Use an appropriate heatsink material around the copper stub and the service valves before applying heat.
- **IMPORTANT:** Do not braze any fitting with the TEV sensing bulb attached.
- Braze the tubing between the outdoor unit and indoor coil. Flow dry nitrogen into a service port and through the tubing while brazing.
- After brazing – use an appropriate heatsink material to cool the joint and remove any flux residue.
- The service valves are not backseating valves. To open the valves, remove the valve cap with an adjustable wrench. Insert a 3/16" or 5/16" hex wrench into the stem. Back out counterclockwise.
- Replace the valve cap finger tight then tighten an additional 1/2 hex flat for a metal-to-metal seal.

TABLE 6
LIQUID LINE SIZE — OUTDOOR UNIT ABOVE INDOOR COIL

| System Capacity | Line Size Connection Size (Inch I.D.) | Line Size (Inch O.D.) | Liquid Line Size Outdoor Unit Above Indoor Coil (Cooling Only - Does not apply to Heat Pumps) | | | | | |
|-----------------|---------------------------------------|-----------------------|---|-----|-----|-----|-----|-----|
| | | | Total | | | | | |
| | | | 25 | 50 | 75 | 100 | 125 | 150 |
| | | | Minimum Vertical Separation - Feet | | | | | |
| 1½ Ton | 3/8" | 1/4 | 0 | 0 | 0 | 0 | 8 | 24 |
| | | 5/16 | 0 | 0 | 0 | 0 | 0 | 0 |
| | | 3/8* | 0 | 0 | 0 | 0 | 0 | 0 |
| 2 Ton | 3/8" | 1/4 | 0 | 3 | 29 | 55 | 81 | 108 |
| | | 5/16 | 0 | 0 | 0 | 0 | 0 | 0 |
| | | 3/8* | 0 | 0 | 0 | 0 | 0 | 0 |
| 2½ Ton | 3/8" | 1/4 | 0 | 14 | 56 | 98 | N/A | N/A |
| | | 5/16 | 0 | 0 | 0 | 0 | 0 | 0 |
| | | 3/8* | 0 | 0 | 0 | 0 | 0 | 0 |
| 3 Ton | 3/8" | 5/16 | 0 | 0 | 0 | 0 | 0 | 9 |
| | | 3/8* | 0 | 0 | 0 | 0 | 0 | 0 |
| 3½ Ton | 3/8" | 5/16 | 0 | 0 | 0 | 16 | 35 | 54 |
| | | 3/8* | 0 | 0 | 0 | 0 | 0 | 0 |
| 4 Ton | 3/8" | 3/8* | 0 | 0 | 0 | 0 | 0 | 0 |
| | | 1/2 | 0 | 0 | 0 | 0 | 0 | 0 |
| 5 Ton | 3/8" | 3/8* | 0 | 0 | 0 | 0 | 0 | 0 |
| | | 1/2 | 0 | 0 | 0 | 0 | 0 | 0 |
| System Capacity | Line Size Connection Size (Inch I.D.) | Line Size (Inch O.D.) | Liquid Line Size Outdoor unit below Indoor Coil | | | | | |
| | | | Total | | | | | |
| | | | 25 | 50 | 75 | 100 | 125 | 150 |
| | | | Maximum Vertical Separation - Feet | | | | | |
| 1½ Ton | 3/8" | 1/4 | 25 | 40 | 25 | 9 | N/A | N/A |
| | | 5/16 | 25 | 50 | 62 | 58 | 53 | 49 |
| | | 3/8* | 25 | 50 | 75 | 72 | 70 | 68 |
| 2 Ton | 3/8" | 1/4 | 23 | N/A | N/A | N/A | N/A | N/A |
| | | 5/16 | 25 | 36 | 29 | 23 | 16 | 9 |
| | | 3/8* | 25 | 50 | 72 | 70 | 68 | 65 |
| 2½ Ton | 3/8" | 1/4 | 25 | N/A | N/A | N/A | N/A | N/A |
| | | 5/16 | 25 | 49 | 38 | 27 | 17 | 6 |
| | | 3/8* | 25 | 50 | 68 | 65 | 62 | 58 |
| 3 Ton | 3/8" | 5/16 | 25 | 50 | 37 | 22 | 7 | N/A |
| | | 3/8* | 25 | 50 | 68 | 63 | 58 | 53 |
| 3½ Ton | 3/8" | 5/16 | 25 | 23 | 4 | N/A | NA | N/A |
| | | 3/8* | 25 | 50 | 43 | 36 | 30 | 24 |
| 4 Ton | 3/8" | 3/8* | 25 | 46 | 38 | 30 | 22 | 15 |
| | | 1/2 | 25 | 50 | 56 | 55 | 53 | 52 |
| 5 Ton | 3/8" | 3/8* | 25 | 50 | 56 | 44 | 32 | 20 |
| | | 1/2 | 25 | 50 | 75 | 81 | 79 | 76 |

*Standard Line Size
N/A - Application not recommended.

LEAK TESTING

- Pressurize line set and coil through service fittings with dry nitrogen to 150 psig maximum. Leak test all joints using liquid detergent. If a leak is found, recover pressure and repair.

WARNING

DO NOT USE OXYGEN TO PURGE LINES OR PRESSURIZE SYSTEM FOR LEAK TEST. OXYGEN REACTS VIOLENTLY WITH OIL, WHICH CAN CAUSE AN EXPLOSION RESULTING IN SEVERE PERSONAL INJURY OR DEATH.

EVACUATION PROCEDURE

Evacuation is the most important part of the entire service procedure. The life and efficiency of the equipment is dependent upon the thoroughness exercised by the serviceman when evacuating air and moisture from the system.

Air in the system causes high condensing temperatures and pressure, resulting in increased power input and non-verifiable performance.

Moisture chemically reacts with the refrigerant and oil to form corrosive hydrofluoric and hydrochloric acids. These attack motor windings and parts, causing breakdown.

After the system has been leak checked and proven sealed, connect the vacuum pump and evacuate system to 500 microns. The vacuum pump must be connected to both the high and low sides of the system through adequate connections. Use the largest size connections available since restrictive service connections may lead to false readings because of pressure drop through the fittings.

IMPORTANT: Compressors (especially scroll type) should never be used to evacuate the air conditioning system because internal electrical arcing may result in a damaged or failed compressor.

START UP AND PERFORMANCE

Even though the unit is factory charged with Refrigerant-410A, the charge must be checked to the charge table attached to the service panel and adjusted, if required. Allow a minimum of 5 minutes running. Before analyzing charge, see the instructions on the unit service panel rating plate for marking the total charge.

CHECKING AIRFLOW

The air distribution system has the greatest effect. The duct system is totally controlled by the contractor. For this reason, the contractor should use only industry-recognized procedures.

The correct air quantity is critical to air conditioning systems. Proper operation, efficiency, compressor life, and humidity control depend on the correct balance between indoor load and outdoor unit capacity. Excessive indoor airflow increases the possibility of high humidity problems. Low indoor airflow reduces total capacity, and causes coil icing. Serious harm can be done to the compressor by low airflow, such as that caused by refrigerant flooding.

Air conditioning systems require a specified airflow. Each ton of cooling requires between 350 and 450 cubic feet of air per minute (CFM), or 400 CFM nominally.

Duct design and construction should be carefully done. System performance can be lowered dramatically through bad planning or workmanship.

Air supply diffusers must be selected and located carefully. They must be sized and positioned to deliver treated air along the perimeter of the space. If they are too small for their intended airflow, they become noisy. If they are not located properly, they cause drafts. Return air grilles must be properly sized to carry air back to the blower. If they are too small, they also cause noise.

The installers should balance the air distribution system to ensure proper quiet air-flow to all rooms in the home. This ensures a comfortable living space.

These simple mathematical formulas can be used to determine the CFM in a residential or light commercial system.

Electric resistance heaters can use

$$\text{CFM} = \frac{\text{volts} \times \text{amps} \times 3.414}{1.08 \times \text{temp rise}}$$

Gas furnaces can use

$$\text{CFM} = \frac{\text{BTUH}}{\Delta T \times 1.08}$$

An air velocity meter or airflow hood can give a more accurate reading of the system CFM's.

CHECKING REFRIGERANT CHARGE

Charge for all systems should be checked against the Charging Chart inside the access panel cover. Before using the chart, the indoor conditions must be within 2°F of desired comfort conditions and system must be run until operating conditions stabilize (15 min. to 30 min.)

CAUTION

THE TOP OF THE SCROLL COMPRESSOR SHELL IS HOT. TOUCHING THE COMPRESSOR TOP MAY RESULT IN SERIOUS PERSONAL INJURY.

IMPORTANT: Do not operate the compressor without charge in system.

Addition of R-410A will raise pressures (vapor, liquid and discharge) and lower vapor temperature.

If adding R-410A raises both vapor pressure and temperature, the unit is over-charged.

IMPORTANT: Use industry-approved charging methods to ensure proper system charge.

CHARGING BY LIQUID PRESSURE

Liquid pressure method is used for charging systems in the cooling mode when an expansion valve is used on the evaporator. The service port on the liquid service valve (small valve) is used for this purpose.

Read and record the outdoor ambient temperature entering the condensing unit, and the liquid line pressure at the service valve (the small valve). Locate the charging chart attached to the unit. The correct liquid line pressure will be found by finding the intersection of the unit model size and the outdoor ambient temperature. Adjust the liquid line pressure but either adding refrigerant to raise pressure or removing refrigerant to lower pressure.

CHARGING UNITS WITH R-410A REFRIGERANT

Checking the charge, or charging units using R-410A refrigerant, differs from those with R-22. The following procedures apply to units with R-410A refrigerant. These procedures require outdoor ambient temperature, liquid line pressure and indoor wet bulb temperature be used.

IMPORTANT: ONLY ADD LIQUID REFRIGERANT CHARGE INTO THE SUCTION LINE WITH R-410A UNITS. USE A COMMERCIAL METERING DEVICE TO ADD CHARGE INTO THE SUCTION LINE WITHOUT DAMAGE TO THE COMPRESSOR.

1. Read and record the outdoor ambient temperature entering the condensing unit.
2. Read and record the liquid line pressure at the small service valve.

3. Read and record the indoor ambient wet bulb temperature entering the indoor coil.
4. Use the appropriate charging chart to compare the actual liquid pressure to the correct pressure as listed on the chart.
5. R-410A charging charts are listed on the unit.

CAUTION

R-410A PRESSURE ARE APPROXIMATELY 60% HIGHER THAN R-22 PRESSURES. USE APPROPRIATE CARE WHEN USING THIS REFRIGERANT. FAILURE TO EXERCISE CARE MAY RESULT IN EQUIPMENT DAMAGE, OR PERSONAL INJURY.

CHARGING BY WEIGHT

For a new installation, evacuation of interconnecting tubing and evaporator coil is adequate; otherwise, evacuate the entire system. Use the factory charge shown in Table 1 of these instructions or unit data plate. Note that charge value includes charge required for 15 ft. of standard size interconnecting liquid line. Calculate actual charge required with installed liquid line size and length using:

- 1/4" O.D. = 0.2 oz./ft.
- 5/16" O.D. = 0.3 oz./ft.
- 3/8" O.D. = 0.5 oz./ft.
- 1/2" O.D. = 1.0 oz./ft.

With an accurate scale (+/- 1 oz.) or volumetric charging device, adjust charge difference between that shown on the unit data plate and that calculated for the new system installation. If the entire system has been evacuated, add the total calculated charge.

NOTE: When the total refrigerant charge volume exceeds the values in Tables 1, 2 and 3, the manufacturer recommends installing a crankcase heater and start kit.

FINAL LEAK TESTING

After the unit has been properly evacuated and charged, a halogen leak detector should be used to detect leaks in the system. All piping within the condensing unit, evaporator, and interconnecting tubing should be checked for leaks. If a leak is detected, the refrigerant should be recovered before repairing the leak. The Clean Air Act prohibits venting refrigerant into the atmosphere.

ELECTRICAL WIRING

Field wiring must comply with the National Electric Code (C.E.C. in Canada) and any applicable local code.

POWER WIRING

It is important that proper electrical power from a commercial utility is available at the condensing unit contactor. Voltage ranges for operation are shown in Table 7.

Install a branch circuit disconnect within sight of the unit and of adequate size to handle the starting current (see Tables 1 and 2).

Power wiring must be run in a rain-tight conduit. Conduit must be run through the connector panel below the access cover (see Figure 1) and attached to the bottom of the control box.

Connect power wiring to contactor located in outdoor condensing unit electrical box. (See wiring diagram attached to unit access panel.)

Check all electrical connections, including factory wiring within the unit and make sure all connections are tight.

TABLE 7
VOLTAGE RANGES (60 HZ)

| Nameplate Voltage | Operating Voltage Range at Copeland Maximum Load Design Conditions for Compressors |
|-------------------|--|
| 208/230 (1 Phase) | 187 - 253 |
| 208/230 (3 Phase) | 187 - 253 |
| 460 | 414 - 506 |
| 575 | 517 - 633 |

DO NOT connect aluminum field wire to the contactor terminals.

GROUNDING

A grounding lug is provided near the contactor for a ground wire.

⚠ WARNING

THE UNIT MUST BE PERMANENTLY GROUNDED. FAILURE TO DO SO CAN CAUSE ELECTRICAL SHOCK RESULTING IN SEVERE PERSONAL INJURY OR DEATH.

FIGURE 3
CONTROL WIRING FOR GAS OR ELECTRIC HEAT

FOR TYPICAL GAS OR OIL HEAT

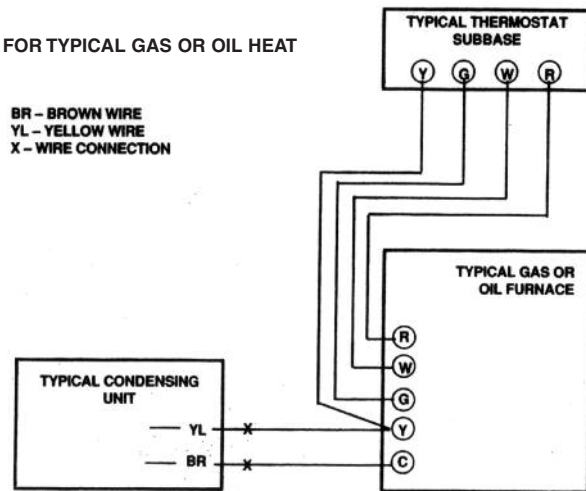

FOR TYPICAL ELECTRIC HEAT

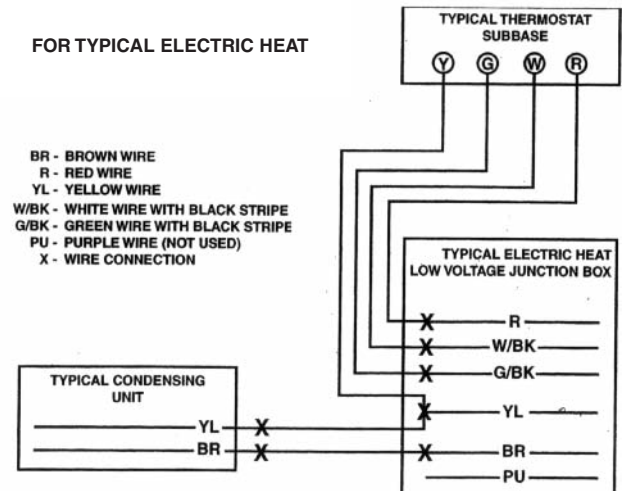

TABLE 8
FIELD WIRE SIZE FOR 24 VOLT THERMOSTAT CIRCUITS

| Thermostat Load - Amps | SOLID COPPER WIRE - AWG. | | | | | |
|------------------------|---------------------------------|-----|-----|-----|-----|-----|
| | 3.0 | 16 | 14 | 12 | 10 | 10 |
| 2.5 | 16 | 14 | 12 | 12 | 10 | 10 |
| 2.0 | 18 | 16 | 14 | 12 | 12 | 10 |
| | 50 | 100 | 150 | 200 | 250 | 300 |
| | Length of Run - Feet (1) | | | | | |

(1) Wire length equals twice the run distance.

NOTE: Do not use control wiring smaller than No. 18 AWG between thermostat and outdoor unit.

CONTROL WIRING

(See Figure 4)

If the low voltage control wiring is run in conduit with the power supply, Class I insulation is required. Class II insulation is required if run separate. Low voltage wiring may be run through the insulated bushing provided in the 7/8 hole in the base panel, up to and attached to the pigtailed from the bottom of the control box. Conduit can be run to the base panel if desired by removing the insulated bushing.

A thermostat and a 24 volt, 40 VA minimum transformer are required for the control circuit of the condensing unit. The furnace or the air handler transformer may be used if sufficient. See the wiring diagram for reference. Use Table 8 to size the 24 volt control wiring.

HIGH AND LOW PRESSURE CONTROLS (HPC OR LPC)

These controls keep the compressor from operating in pressure ranges which can cause damage to the compressor. Both controls are in the low voltage control circuit.

High pressure control (HPC) is a manual reset which opens near 610 PSIG. Do not reset arbitrarily without first determining what caused it to trip.

The low pressure control (LPC) is an automatic reset which opens near 50 PSIG and closes near 95 PSIG.

NOTE: High and low pressure controls are standard on all (-)ANL, (-)APL, (-)APM models.

FIELD INSTALLED ACCESSORIES COMPRESSOR CRANKCASE HEAT (CCH)

While scroll compressors usually do not require crankcase heaters, there are instances when a heater should be added. Refrigerant migration during the off cycle can result in a noisy start up. Add a crankcase heater to minimize refrigeration migration, and to help eliminate any start up noise or bearing "wash out."

NOTE: A crankcase heater should be installed if: the charge of the system exceeds the values in Tables 4 and 5, if the system is subject to voltage variations or when a low ambient control is used for system operation below 55°F.

All heaters are located on the lower half of the compressor shell. Its purpose is to drive refrigerant from the compressor shell during long off cycles, thus preventing damage to the compressor during start-up.

At initial start-up or after extended shutdown periods, make sure the heater is energized for at least 12 hours before the compressor is started. (Disconnect switch on and wall thermostat off.)

TABLE 9
MAXIMUM SYSTEM CHARGE VALUES (-)ANL

| (-)ANL Model Size | Compressor Model Number | Charge Limit Without Crankcase Heat (3 Phase) | Charge Limit Without Crankcase Heat (1 Phase) |
|-------------------|-------------------------|---|---|
| 18 | ZP16K5E | 8 lbs. | 9.6 lbs. |
| 24 | ZP21K5E | 8 lbs. | 9.6 lbs. |
| 30/31 | ZP25K5E | 8 lbs. | 9.6 lbs. |
| 36/37 | ZP34K5E | 10 lbs. | 12 lbs. |
| 42 | ZP36K5E | 10 lbs. | 12 lbs. |
| 43 | ZP38K5F | 10 lbs. | 12 lbs. |
| 48/49 | ZP42K5E | 10 lbs. | 12 lbs. |
| 60 | ZP54K5E | 10 lbs. | 12 lbs. |

TABLE 10
MAXIMUM SYSTEM CHARGE VALUES (-)APL

| (-)APL Model Size | Compressor Model Number | Charge Limit Without Crankcase Heat (1 Phase) |
|-------------------|-------------------------|---|
| 18 | ZP16K5E | 9.6 lbs. |
| 24 | ZP20K5E | 9.6 lbs. |
| 30 | ZP24K5E | 9.6 lbs. |
| 36 | ZP31K5E | 9.6 lbs. |
| 42 | ZP36K5E | 12 lbs. |
| 48 | ZP42K5E | 12 lbs. |
| 60 | ZP51K5E | 12 lbs. |

TABLE 11
MAXIMUM SYSTEM CHARGE VALUES (-)APM

| (-)APM Model Size | Compressor Model Number | Charge Limit Without Crankcase Heat (1 Phase) |
|-------------------|-------------------------|---|
| 18 | ZP16K5E | 9.6 lbs. |
| 24 | ZP20K5E | 9.6 lbs. |
| 30 | ZP24K5E | 9.6 lbs. |
| 36 | ZP31K5E | 9.6 lbs. |
| 42 | ZP34K5E | 12 lbs. |
| 48 | ZP42K5E | 12 lbs. |
| 60 | ZP51K5E | 12 lbs. |

HARD START COMPONENTS

Start components are not usually required with the scroll compressors used in (-)ANL/(-)APL/(-)APM condensing units, but are available for special cases and where start components are desirable to reduce light dimming.

TIME DELAY CONTROL (TDC)

The time delay (TDC) is in the low voltage control circuit. When the compressor shuts off due to a power failure or thermostat operation, this control keeps it off at least 5 minutes which allows the system pressure to equalize, thus not damaging the compressor or blowing fuses on start-up.

LOW AMBIENT CONTROL (LAC)

This component senses compressor head pressure and shuts the condenser fan off when the head pressure drops below designated levels. This allows the unit to build a sufficient head pressure at lower ambient in order to maintain system balance and obtain improved capacity. Low ambient control should be used on all equipment operated below 65°F ambient.

OUTDOOR UNIT COVERS

Outdoor condensing unit covers are available if the homeowner requests a cover for their unit. With the complete model number for the unit, the correct cover can be obtained through an authorized distributor.

CAUTION

FAILURE TO REMOVE CONDENSING UNIT COVER BEFORE OPERATING OUTDOOR UNIT CAN CAUSE COMPONENTS TO FAIL.

SERVICE

SINGLE-POLE COMPRESSOR CONTACTOR (CC)

Single-pole contactors are used on all standard single phase units up through 5 tons. Caution must be exercised when servicing as only one leg of the power supply is broken with the contactor. Two pole contactors are used on some three phase units.

TROUBLE SHOOTING

In diagnosing common faults in the air conditioning system, it is useful to present the logical pattern of thought that is used by experienced technicians. The charts which follow are not intended to be an answer to all problems, but only to guide your thinking as you attempt to decide on your course of action. Through a series of yes and no answers, you will follow the logical path to a likely conclusion.

Use these charts as you would a road map, if you are a beginning technician. As you gain experience, you will learn where to establish the shortcuts. Remember that the chart will help clarify the logical path to the problem.

ELECTRICAL CHECKS FLOW CHART

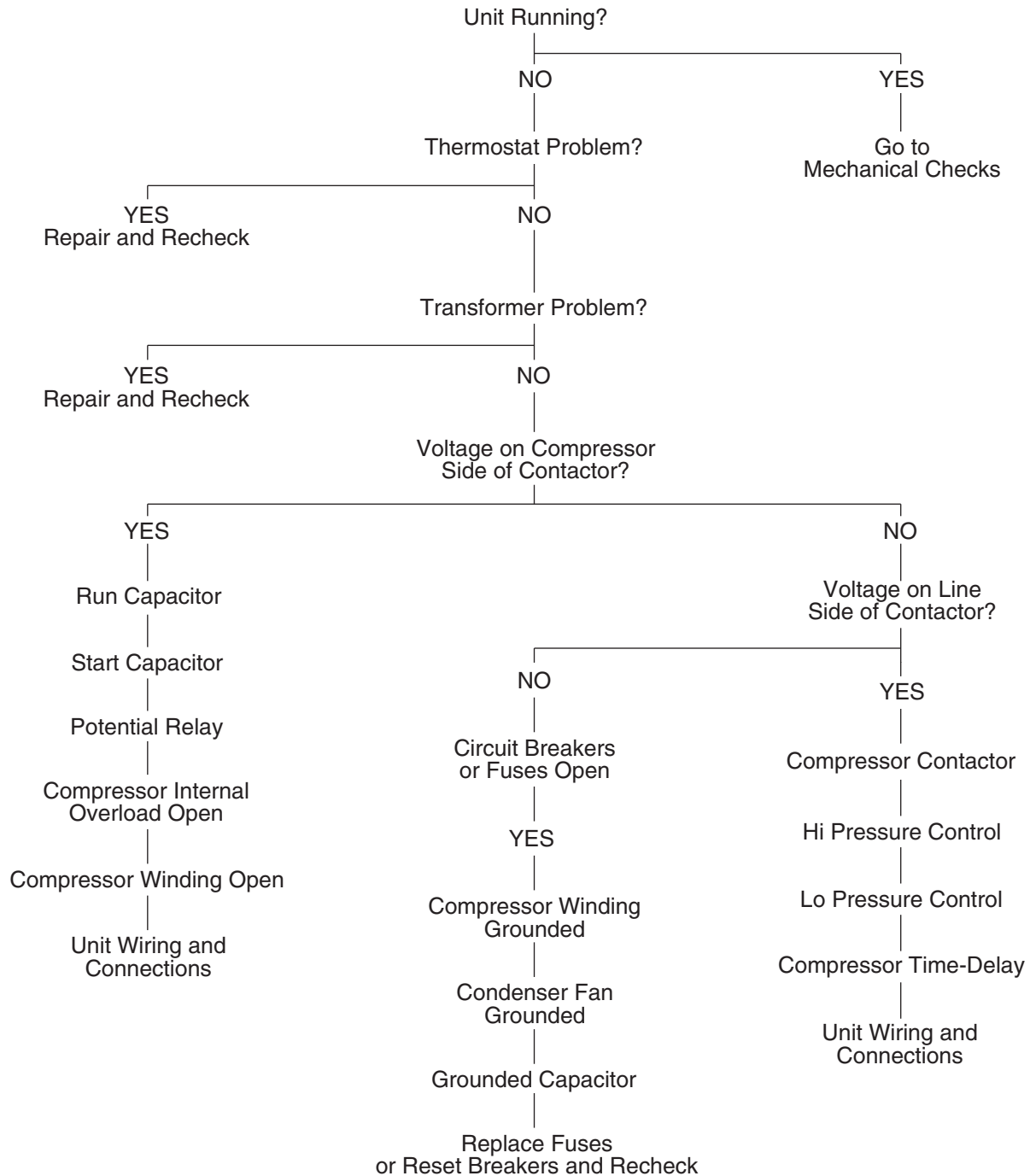

MECHANICAL CHECKS FLOW CHART

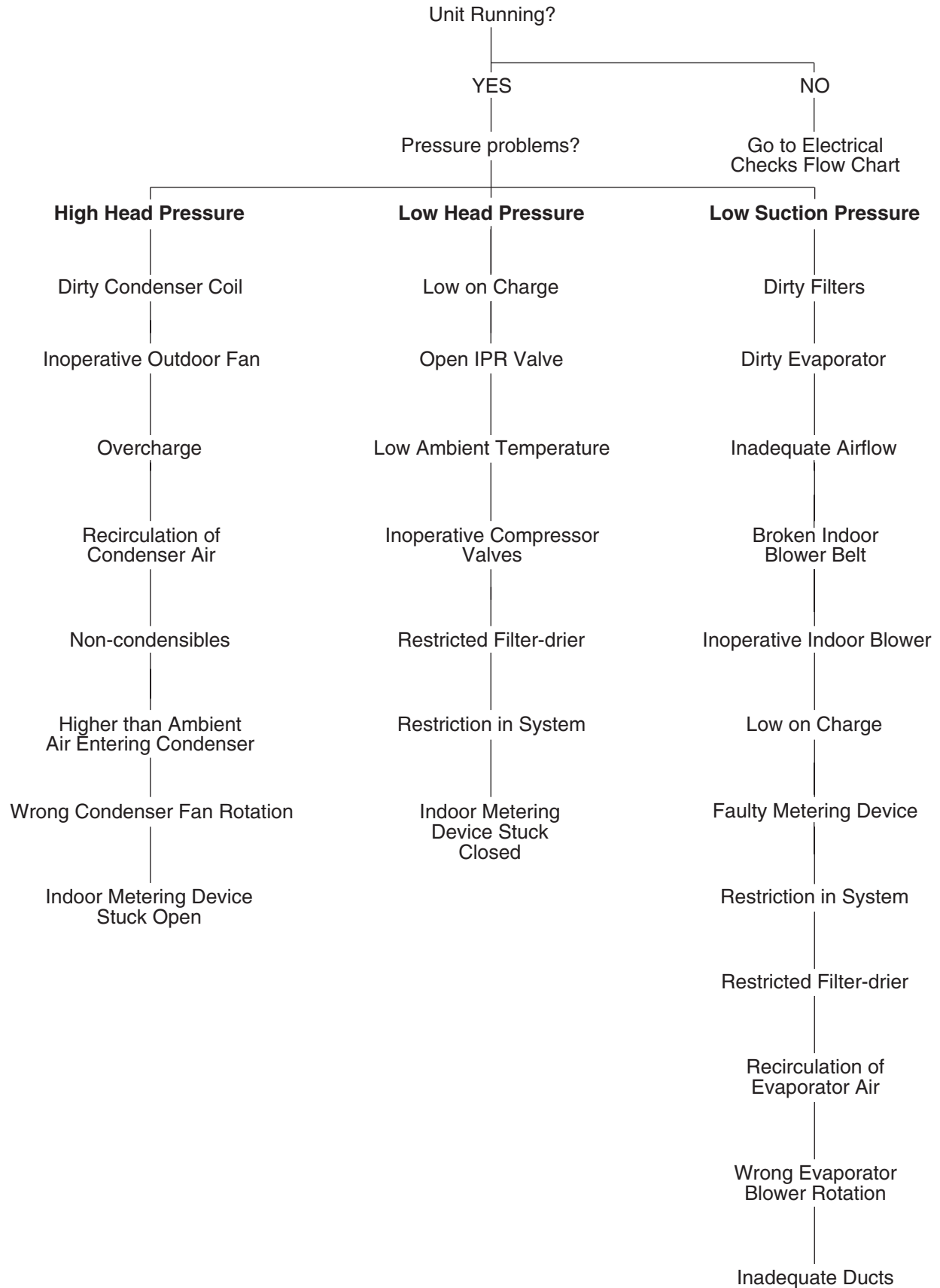

TABLE 12
TEMPERATURE PRESSURE CHART

| TEMP (Deg. F) | R-410A PSIG |
|------------------|----------------|
| -150 | — |
| -140 | — |
| -130 | — |
| -120 | — |
| -110 | — |
| -100 | — |
| -90 | — |
| -80 | — |
| -70 | — |
| -60 | 0.4 |
| -50 | 5.1 |
| -40 | 10.9 |
| -35 | 14.2 |
| -30 | 17.9 |
| -25 | 22.0 |
| -20 | 26.4 |
| -15 | 31.3 |
| -10 | 36.5 |
| -5 | 42.2 |
| 0 | 48.4 |
| 5 | 55.1 |
| 10 | 62.4 |
| 15 | 70.2 |
| 20 | 78.5 |
| 25 | 87.5 |
| 30 | 97.2 |
| 35 | 107.5 |
| 40 | 118.5 |
| 45 | 130.2 |
| 50 | 142.7 |
| 55 | 156.0 |
| 60 | 170.1 |
| 65 | 185.1 |
| 70 | 201.0 |
| 75 | 217.8 |
| 80 | 235.6 |
| 85 | 254.5 |
| 90 | 274.3 |
| 95 | 295.3 |
| 100 | 317.4 |
| 105 | 340.6 |
| 110 | 365.1 |
| 115 | 390.9 |
| 120 | 418.0 |
| 125 | 446.5 |
| 130 | 476.5 |
| 135 | 508.0 |
| 140 | 541.2 |
| 145 | 576.0 |
| 150 | 612.8 |

SUPERHEAT CALCULATION

1. Measure the suction pressure at the suction line service valve.
2. Convert the suction pressure to saturated temperature. See Table 12.
3. Measure the temperature of the suction line at the suction line service valve.
4. Compare the temperature of the suction line to the saturated temperature.
5. The difference between saturated temperature and suction line temperature is the superheat. Superheat normal range 12° to 15°.

SUBCOOLING CALCULATION

1. Measure the liquid pressure at the liquid line service valve.
2. Convert the liquid line pressure to saturated temperature. See Table 13.
3. Measure the liquid line temperature at the liquid line service valve.
4. Compare the liquid line temperature to the saturated temperature.
5. The difference between saturated temperature and liquid line temperature is the subcooling. Subcooling normal range 9° to 12°.

TABLE 13
AIR CONDITIONING SYSTEM TROUBLESHOOTING TIPS

| AIR CONDITIONING SYSTEM TROUBLESHOOTING TIPS | | | | | |
|---|-----------------------|---------------------|-----------|------------|--------------------|
| SYSTEM PROBLEM | INDICATORS | | | | |
| | DISCHARGE PRESSURE | SUCTION PRESSURE | SUPERHEAT | SUBCOOLING | COMPRESSOR AMPS |
| Overcharge | High | High | Low | High | High |
| Undercharge | Low | Low | High | Low | Low |
| Liquid Restriction (Drier) | Low | Low | High | High | Low |
| Low Evaporator Airflow | Low | Low | Low | Low | Low |
| Dirty Condenser | High | High | Low | Low | High |
| Low Outside Ambient Temperature | Low | Low | High | High | Low |
| Inefficient Compressor | Low | High | High | High | Low |
| TEV Feeler Bulb Charge Lost | Low | Low | High | High | Low |
| Poorly Insulated Sensing Bulb | High | High | Low | Low | High |

TROUBLE SHOOTING CHART

▲ WARNING

DISCONNECT ALL POWER TO UNIT BEFORE SERVICING. CONTACTOR MAY BREAK ONLY ONE SIDE. FAILURE TO SHUT OFF POWER CAN CAUSE ELECTRICAL SHOCK RESULTING IN PERSONAL INJURY OR DEATH.

| SYMPTOM | POSSIBLE CAUSE | REMEDY |
|--|---|--|
| Unit will not run | <ul style="list-style-type: none"> • Power off or loose electrical connection • Thermostat out of calibration-set too high • Defective contactor • Blown fuses / tripped breaker • Transformer defective • High pressure control open (if provided) | <ul style="list-style-type: none"> • Check for correct voltage at contactor in condensing unit • Reset • Check for 24 volts at contactor coil - replace if contacts are open • Replace fuses / reset breaker • Check wiring-replace transformer • Reset-also see high head pressure remedy-The high pressure control opens at 450 PSIG |
| Outdoor fan runs, compressor doesn't | <ul style="list-style-type: none"> • Run or start capacitor defective • Start relay defective • Loose connection • Compressor stuck, grounded or open motor winding, open internal overload. • Low voltage condition | <ul style="list-style-type: none"> • Replace • Replace • Check for correct voltage at compressor - check & tighten all connections • Wait at least 2 hours for overload to reset. If still open, replace the compressor. • Add start kit components |
| Insufficient cooling | <ul style="list-style-type: none"> • Improperly sized unit • Improper indoor airflow • Incorrect refrigerant charge • Air, non-condensibles or moisture in system | <ul style="list-style-type: none"> • Recalculate load • Check - should be approximately 400 CFM per ton. • Charge per procedure attached to unit service panel • Recover refrigerant, evacuate & recharge, add filter drier |
| Compressor short cycles | <ul style="list-style-type: none"> • Incorrect voltage • Defective overload protector • Refrigerant undercharge | <ul style="list-style-type: none"> • At compressor terminals, voltage must be $\pm 10\%$ of nameplate marking when unit is operating. • Replace - check for correct voltage • Add refrigerant |
| Registers sweat | <ul style="list-style-type: none"> • Low indoor airflow | <ul style="list-style-type: none"> • Increase speed of blower or reduce restriction - replace air filter |
| High head-low vapor pressures | <ul style="list-style-type: none"> • Restriction in liquid line, expansion device or filter drier • Flowcheck piston size too small • Incorrect capillary tubes | <ul style="list-style-type: none"> • Remove or replace defective component • Change to correct size piston • Change coil assembly |
| High head-high or normal vapor pressure - Cooling mode | <ul style="list-style-type: none"> • Dirty outdoor coil • Refrigerant overcharge • Outdoor fan not running • Air or non-condensibles in system | <ul style="list-style-type: none"> • Clean coil • Correct system charge • Repair or replace • Recover refrigerant, evacuate & recharge |
| Low head-high vapor pressures | <ul style="list-style-type: none"> • Flowcheck piston size too large • Defective Compressor valves • Incorrect capillary tubes | <ul style="list-style-type: none"> • Change to correct size piston • Replace compressor • Replace coil assembly |
| Low vapor - cool compressor - iced indoor coil | <ul style="list-style-type: none"> • Low indoor airflow • Operating below 65°F outdoors • Moisture in system | <ul style="list-style-type: none"> • Increase speed of blower or reduce restriction - replace air filter • Add Low Ambient Kit • Recover refrigerant - evacuate & recharge - add filter drier |
| High vapor pressure | <ul style="list-style-type: none"> • Excessive load • Defective compressor | <ul style="list-style-type: none"> • Recheck load calculation • Replace |
| Fluctuating head & vapor pressures | <ul style="list-style-type: none"> • TEV hunting • Air or non-condensibles in system | <ul style="list-style-type: none"> • Check TEV bulb clamp - check air distribution on coil - replace TEV • Recover refrigerant, evacuate & recharge |
| Gurgle or pulsing noise at expansion device or liquid line | <ul style="list-style-type: none"> • Air or non-condensibles in system | <ul style="list-style-type: none"> • Recover refrigerant, evacuate & recharge |

FIGURE 4
SINGLE-PHASE WIRING DIAGRAM

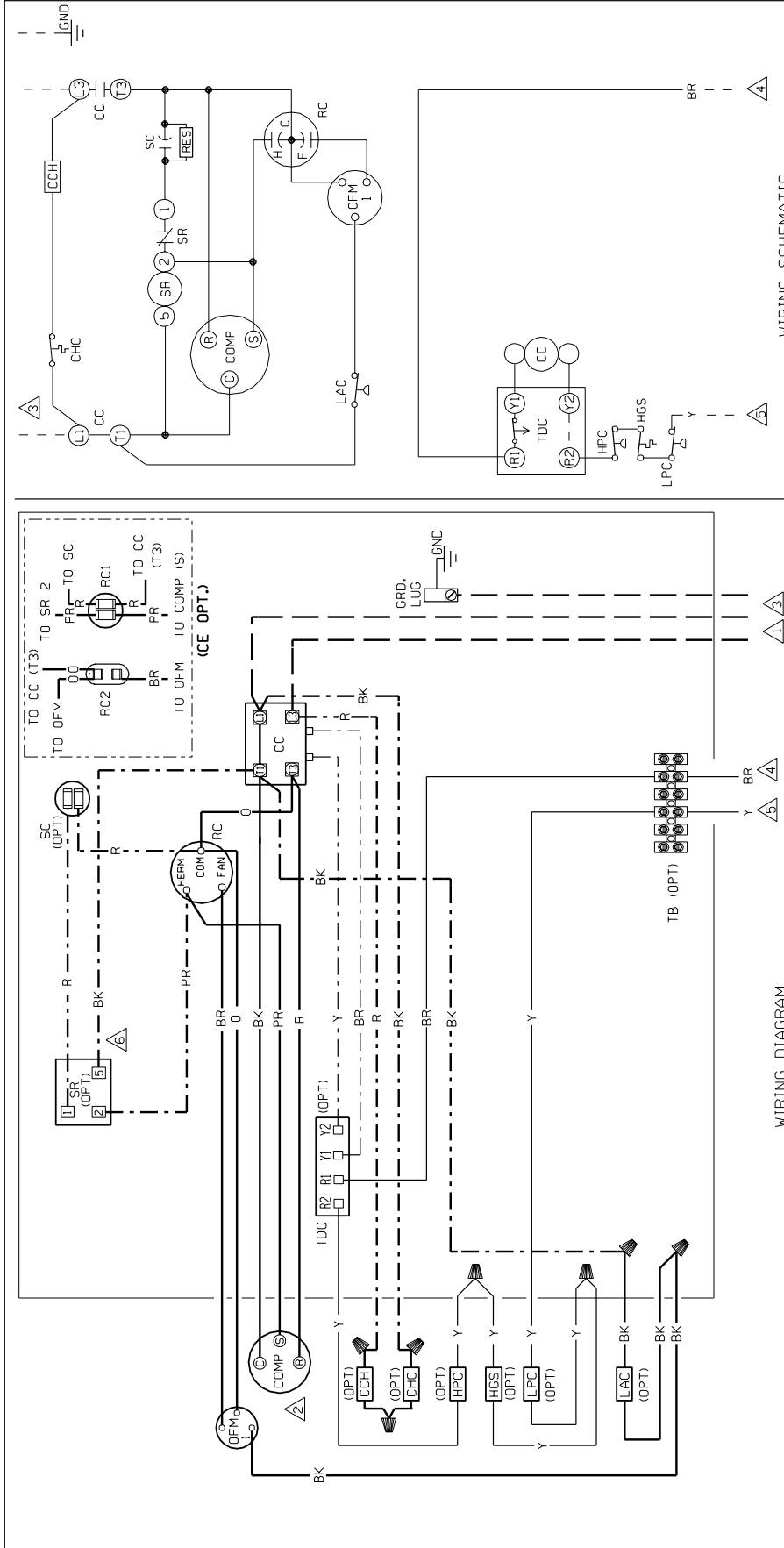

WIRING SCHEMATIC

WIRING DIAGRAM

| | | | | | |
|--|---|--|---|---|--|
| <p>COMPONENT CODE</p> <p>CC COMPRESSION CONTROL CCH CRANKCASE HEATER CONTROL CHC CRANKCASE HEATER CONTROL GND GROUND GND GROUND HPC HIGH PRESSURE CONTROL LAC LOW AMBIENT COILING CONTROL OFM OUTDOOR FAN MOTOR OPT OPTIONAL PTCR POSITIVE TEMPERATURE COEFFICIENT RELAY RUS FUSIBLE RELAY SC START CAPACITOR SR START RELAY TB TERMINAL BLOCK TDC TIME DELAY CONTROL</p> | <p>NOTES:</p> <ol style="list-style-type: none"> CONNECTORS SUITABLE FOR USE WITH COPPER CONDUCTORS ONLY. COMPRESSOR MOTOR THERMALLY PROTECTED AND ALL 3 PHASE ARE PROTECTED UNDER PRIMARY SINGLE PHASE CONDITIONS. CONNECT FIELD WIRING IN GROUNDED RAINIGHT CONDUIT TO FUSED DISCONNECT, VOLTAGE, HERTZ AND PHASE PER RATING PLATE. LOW VOLTAGE CIRCUIT TO BE N.E.C. CLASS 2 WITH A CLASS 2 TRANSFORMER 24 VOLT, 50 OR 60 HERTZ. TO THERMOSTAT SUB-BASE, REFER TO SYSTEM SCHEMATICS OR SCHEMATICS ON INDOOR SECTION FOR LOW VOLTAGE CONTROL WIRING. BLACK WIRE FROM SR (5) TO CC (11) DELETED WHEN PTCR IS USED. | <p>WIRING INFORMATION</p> <p>LINE VOLTAGE -FACTORY STANDARD -FACTORY OPTION -FIELD INSTALLED LOW VOLTAGE -FACTORY STANDARD -FACTORY OPTION -FIELD INSTALLED REPLACEMENT WIRE -MUST BE THE SAME SIZE AND TYPE OF INSULATION AS ORIGINAL (105 C. MIN.) -WARNING -CABINET MUST BE PERMANENTLY GROUNDED AND CONFORM TO I.E.C., N.E.C., C.E.C., NATIONAL WIRING REGULATIONS, AND LOCAL CODES AS APPLICABLE.</p> | <p>WIRE COLOR CODE</p> <p>BK BLACK BR BROWN BL BLUE G GREEN GR GRAY O ORANGE PR PURPLE R RED W WHITE Y YELLOW</p> | <p>ELECTRICAL WIRING DIAGRAM</p> <p>REMOTE AIR CONDITIONER SINGLE PHASE</p> | <p>DR. BY MB APP. BY JW DATE 1-28-92 DWG. NO. 90-23238-01 REV 12</p> |
|--|---|--|---|---|--|

FIGURE 5
THREE-PHASE WIRING DIAGRAM (C, D & Y VOLTAGES)

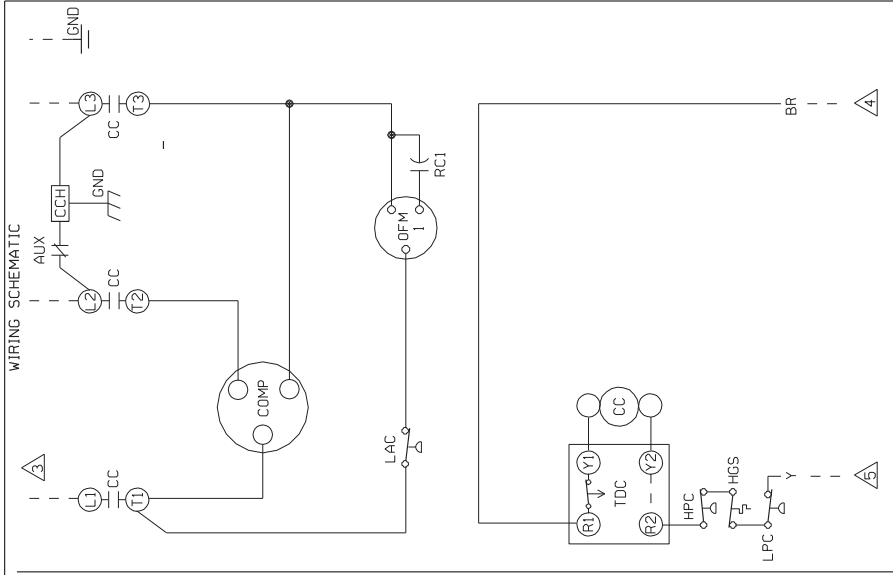
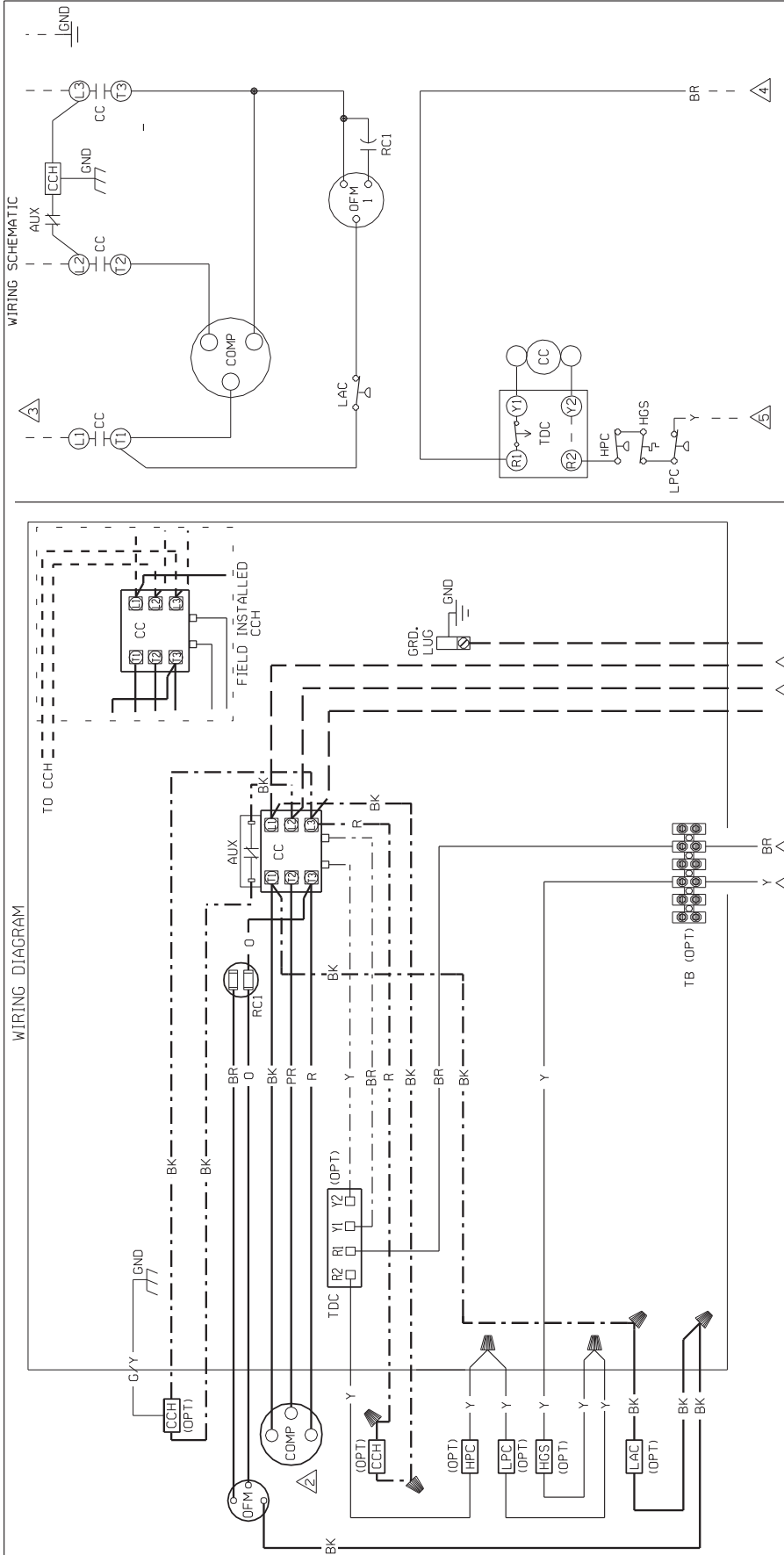

| WIRE COLOR CODE | |
|-----------------|--------|
| BK | BLACK |
| BR | BROWN |
| BL | BLUE |
| G | GREEN |
| GY | GRAY |
| O | ORANGE |
| PR | PURPLE |
| R | RED |
| W | WHITE |
| Y | YELLOW |

ELECTRICAL WIRING DIAGRAM
REMOTE AIR CONDITIONER
THREE PHASE

WIRING INFORMATION

- LINE VOLTAGE
- FACTORY STANDARD
- FACTORY OPTION
- FIELD INSTALLED
- LOW VOLTAGE
- FACTORY STANDARD
- FACTORY OPTION
- FIELD INSTALLED
- REPLACEMENT WIRE
- MUST BE THE SAME SIZE AND TYPE OF INSULATION AS ORIGINAL (105 C.MIN.)

WARNING
 -CABINET MUST BE PERMANENTLY GROUNDED AND CONFORM TO I.E.C., N.E.C., C.E.C., NATIONAL WIRING REGULATIONS, AND LOCAL CODES AS APPLICABLE.

- NOTES:**
- CONNECTORS SUITABLE FOR USE WITH COPPER CONDUCTORS ONLY.
 - COMPRESSOR MOTOR THERMALLY PROTECTED AND ALL 3 PHASE ARE PROTECTED UNDER PRIMARY SINGLE PHASE CONDITIONS.
 - CONNECT FIELD WIRING IN GROUNDED RAINTIGHT CONDUIT TO USED DISCONNECT, VOLTAGE, HERTZ AND PHASE PER RATING PLATE.
 - LOW VOLTAGE CIRCUIT TO BE N.E.C. CLASS 2 WITH A CLASS 2 TRANSFORMER 24 VOLT, 50 OR 60 HERTZ.
 - TO THERMOSTAT SUB-BASE REFER TO SYSTEM SCHEMATICS OR SCHEMATICS ON INDOOR SECTION FOR LOW VOLTAGE CONTROL WIRING.

| COMPONENT CODE | |
|----------------|-------------------------------|
| CCH | COMPRESSOR CONTACTOR |
| COMP | COMPRESSOR |
| GND | GROUND, CHASSIS |
| HGS | HOT GAS SENSOR |
| LAC | HIGH PRESSURE CUT-OUT CONTROL |
| LPC | LOW PRESSURE CONTROL |
| OFM | OUTDOOR FAN MOTOR |
| OPT | OPTIONAL |
| RCS | RUS. CAPACITOR |
| SCS | START CAPACITOR |
| SR | START RELAY |
| TB | TERMINAL BLOCK |
| TDC | TIME DELAY CONTROL |

| | | | |
|----------|--------------|-----|----|
| DWG. NO. | 90-101229-08 | REV | 01 |
|----------|--------------|-----|----|

| | | | | |
|--------|---------|---------|--------------|-----|
| DR. BY | APP. BY | DATE | DWG. NO. | REV |
| MCB | | 9-19-05 | 90-101229-08 | 01 |

FIGURE 6

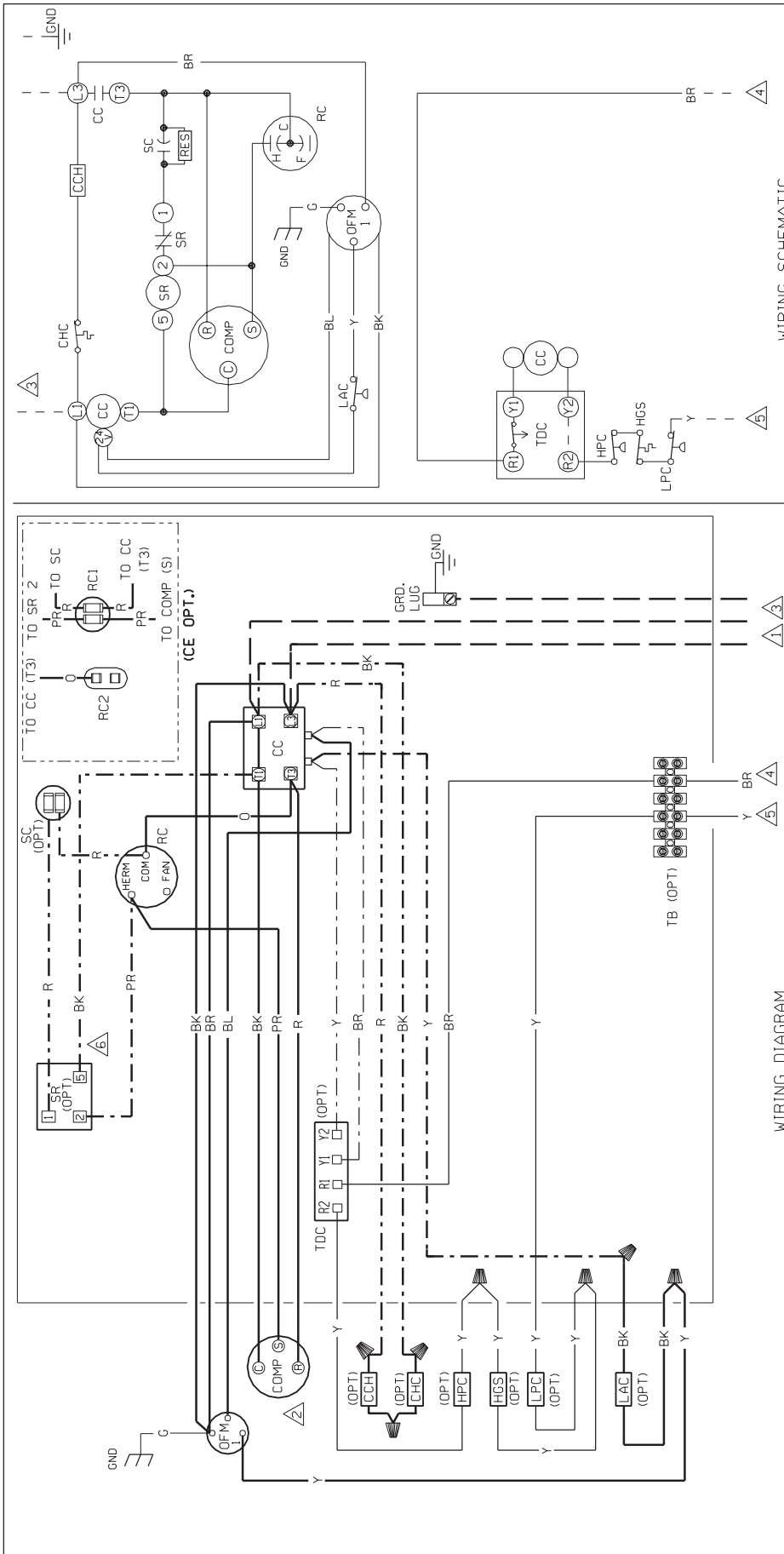

| | | | |
|--|---|--|--|
| <p>COMPONENT CODE</p> <p>CCH COMPRESSOR CONTACTOR CRK CRANKCASE HEATER CONTROL CCR COMPRESSOR GND GROUND, CHASSIS HGS HIGH PRES. CUT-OUT CONTROL LFC LOW PRESSURE CONTROL OFM OUTDOOR FAN MOTOR OPT OPTIONAL PTCR POSITIVE TEMPERATURE COEFFICIENT RELAY RLS FUSE CAPACITOR SC START RELAY SR START RELAY TB TERMINAL BLOCK TDC TIME DELAY CONTROL</p> | <p>WIRING INFORMATION</p> <p>LINE VOLTAGE -FACTORY STANDARD -FACTORY OPTION -FIELD INSTALLED LOW VOLTAGE -FACTORY STANDARD -FACTORY OPTION -FIELD INSTALLED REPLACEMENT WIRE -MUST BE THE SAME SIZE AND TYPE OF INSULATION AS ORIGINAL (105 C-MIN.) -CABINET MUST BE PERMANENTLY GROUNDED AND CONFORM TO I.E.C., N.E.C., C.E.C., NATIONAL WIRING REGULATIONS, AND LOCAL CODES AS APPLICABLE.</p> | <p>NOTES:</p> <ol style="list-style-type: none"> CONNECTORS SUITABLE FOR USE WITH COPPER CONDUCTORS ONLY. COMPRESSOR MOTOR, THERMALLY PROTECTED AND ALL 3 PHASE ARE PROTECTED UNDER PRIMARY SINGLE PHASE CONDITIONS. CONNECT FIELD WIRING IN GROUNDED RAINIGHT CONDUIT TO FUSED DISCONNECT, VOLTAGE, HERTZ AND PHASE PER RATING PLATE. LOW VOLTAGE CIRCUIT TO BE N.E.C. CLASS 2 WITH A CLASS 2 TRANSFORMER 24 VOLT, 50 OR 60 HERTZ. TO THERMOSTAT SUB-BASE, REFER TO SYSTEM SCHEMATICS OR SCHEMATICS ON INDOOR SECTION FOR LOW VOLTAGE CONTROL WIRING. BLACK WIRE FROM SR (6) TO CC (1) DELETED WHEN PTCR IS USED. IF LAC/LAR IS NOT USED, CONNECT YELLOW WIRE FROM OFM TO 24V CC. | <p>WIRE COLOR CODE</p> <p>BK BLACK BR BROWN BL BLUE G GREEN GY GRAY O ORANGE PR PURPLE R RED W WHITE Y YELLOW</p> <p>ELECTRICAL WIRING DIAGRAM</p> <p>REMOTE AIR CONDITIONER SINGLE PHASE WITH OUTDOOR ECM MOTOR</p> <p>DR. BY: MGR APP. BY: DATE 10-7-98 DWG. NO. 90-103021-01 REV 00</p> |
|--|---|--|--|

