

INSTALLATION INSTRUCTIONS

AIR-COOLED CONDENSING UNITS

EQUIPPED WITH THE *COMFORT CONTROL SYSTEM™*

(-)ANL-JEZ MODEL SERIES - 13 SEER

(-)APM-JEZ MODEL SERIES - 14.5 SEER



FEATURING INDUSTRY STANDARD
R-410A REFRIGERANT **R-410A**



RECOGNIZE THIS SYMBOL AS AN INDICATION OF IMPORTANT SAFETY INFORMATION!

⚠ WARNING

THESE INSTRUCTIONS ARE INTENDED AS AN AID TO QUALIFIED, LICENSED SERVICE PERSONNEL FOR PROPER INSTALLATION, ADJUSTMENT AND OPERATION OF THIS UNIT. READ THESE INSTRUCTIONS THOROUGHLY BEFORE ATTEMPTING INSTALLATION OR OPERATION. FAILURE TO FOLLOW THESE INSTRUCTIONS MAY RESULT IN IMPROPER INSTALLATION, ADJUSTMENT, SERVICE OR MAINTENANCE POSSIBLY RESULTING IN FIRE, ELECTRICAL SHOCK, PROPERTY DAMAGE, PERSONAL INJURY OR DEATH.

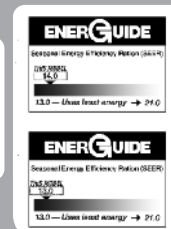

ISO 9001:2008

Certificate Number: 30164

DO NOT DESTROY THIS MANUAL

PLEASE READ CAREFULLY AND KEEP IN A SAFE PLACE FOR FUTURE REFERENCE BY A SERVICEMAN



[] INDICATES METRIC CONVERSIONS

92-21354-55-11
SUPERSEDES 92-21354-55-10

TABLE OF CONTENTS

Checking Product Received	2
Dimensions	3
Electrical & Physical Data	4
General	5
Application	5
Locating Unit	5
Unit Mounting	7
Factory-Preferred Tie-Down Method	7
Refrigerant Connections	7
Tools Required for Installing & Servicing R-410A Models	7
Specification of R-410A	8
Quick Reference Guide For R-410A	8
Replacement Units	8
Evaporator Coil	8
Interconnecting Tubing	9
Evacuation Procedure	11
Start-Up and Performance	11
Checking Airflow	13
Checking Refrigerant Charge	13
Charging by Liquid Pressure	14
Charging by Units with R-410A Refrigerant	14
Charging by Weight	14
Final Leak Testing	15
Electrical Wiring	15
Hard Start Components	16
High and Low Pressure Controls (HPC or LPC)	17
Field Installed Accessories	17
Comfort Control System	18
Control Description	18
ICC Control Operation	19
Active Compressor Protection Mode	20
Test and Fault Recall Modes	21
Status and Diagnostic Description	22-23
Service	23
Troubleshooting	24-27
Service Analyzer Charts	28-32
ANL-JEZ-Diagnostic Label	33-34
Wiring Diagram	35

CHECKING PRODUCT RECEIVED

Upon receiving unit, inspect it for any shipping damage. Claims for damage, either apparent or concealed, should be filed immediately with the shipping company. Check condensing unit model number, electrical characteristics and accessories to determine if they are correct and match the original order from the local distributor. Check system components (evaporator coil, condensing unit, evaporator blower, etc.) to make sure they are properly matched.

FIGURE 1
DIMENSIONS AND INSTALLATION CLEARANCES

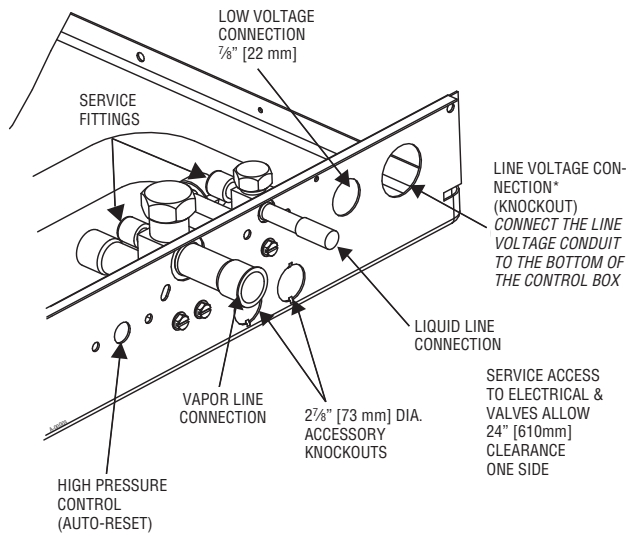
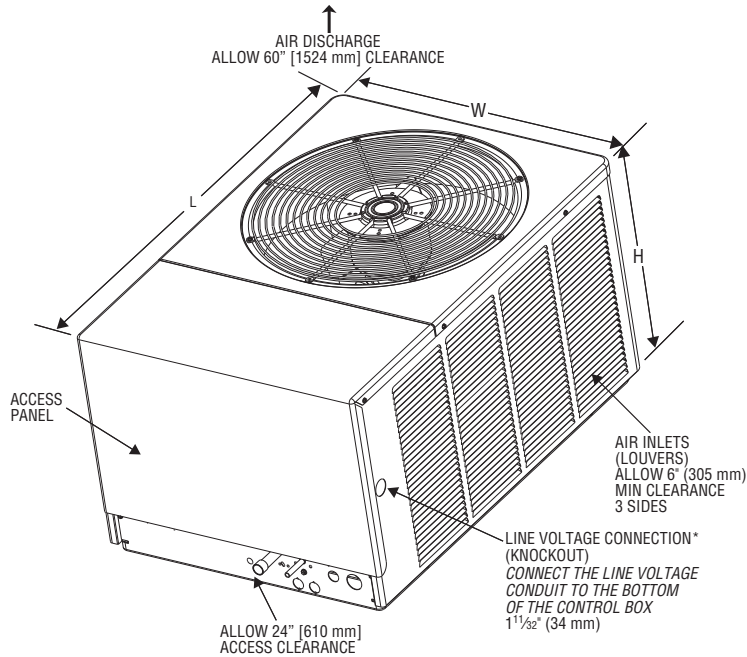

UNIT MODEL NUMBER EXPLANATION

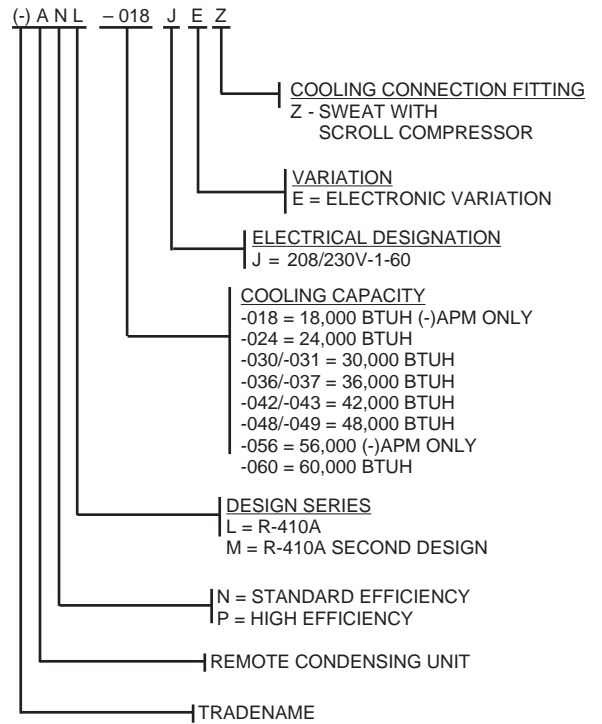

BASE PAN

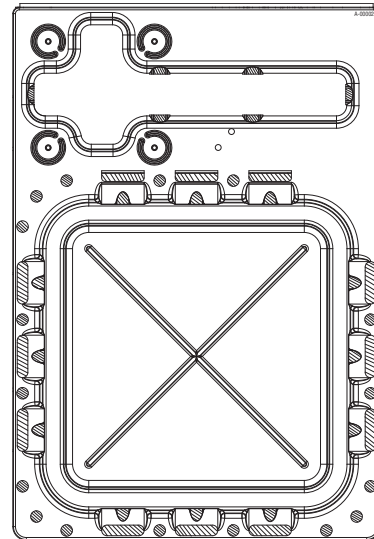

BOTTOM VIEW SHOWING DRAIN OPENINGS (////// SHADED AREAS).

DIMENSIONAL DATA

CONDENSING UNIT MODEL (-)ANL	024JEZ/031JEZ	043/037JEZ	049JEZ	060JEZ
HEIGHT "H" (INCHES)	19"	23"	29"	33"
LENGTH "L" (INCHES)	40½"	44¾"	44¾"	44¾"
WIDTH "W" (INCHES)	27⅝"	31½"	31½"	31½"

CONDENSING UNIT MODEL (-)APM	018JEZ	024JEZ/030JEZ	036JEZ / 042JEZ / 048JEZ / 056JEZ / 060JEZ
HEIGHT "H" (INCHES)	19"	29"	33"
LENGTH "L" (INCHES)	40½"	44¾"	44¾"
WIDTH "W" (INCHES)	27⅝"	31½"	31½"

TABLE 1

(-)ANL ELECTRICAL AND PHYSICAL DATA

Model Number (-)ANL-	Phase Frequency (Hz) Voltage (Volts)	ELECTRICAL						PHYSICAL					
		Compressor		Fan Motor Full Load Amperes (FLA)	Minimum Circuit Ampacity Amperes	Fuse or HACR Circuit Breaker		Outdoor Coil			R-410A Oz. [g]	Weight	
		Rated Load Amperes (RAL)	Locked Rotor Amperes (LRA)			Minimum Amperes	Maximum Amperes	Face Area Sq. Ft. [m ²]	No. Rows	CFM [L/s]		Net Lbs. [kg]	Shipping Lbs. [kg]
024JEZ	1-60-208-230	12.8/12.8	58.3	0.6	17/17	20/20	25/25	11 [1.02]	1	1920 [906]	72 [2041]	140 [63.5]	150 [68]
031JEZ	1-60-208-230	14.1/14.1	73	0.6	19/19	25/25	30/30	11 [1.02]	1	1920 [906]	83 [2353]	142 [65]	152 [70]
037JEZ	1-60-208-230	17.9/17.9	112	1.2	24/24	30/30	40/40	16.1 [1.5]	1	2300 [1085]	106 [3005]	160 [72]	170 [77]
043JEZ	1-60-208-230	17.9/17.9	109	1.2	27/27	35/35	45/45	17.26 [1.6]	1	3200 [1510]	115 [3260]	205 [93]	215 [97]
049JEZ	1-60-208-230	21.8/21.8	117	1.2	29/29	35/35	50/50	20.1 [1.8]	1	3200 [1510]	132 [3742]	235 [106]	245 [111]
060JEZ	1-60-208-230	26.3/26.3	134	1.2	35/35	45/45	60/60	23.01 [2.14]	1	3500 [1652]	180 [5103]	250 [113.4]	260 [117.9]

NOTE: Factory refrigerant charge includes refrigerant for 15 feet of standard line set.

TABLE 2

(-)APM ELECTRICAL AND PHYSICAL DATA

Model Number RAPM-	Phase Frequency (Hz) Voltage (Volts)	ELECTRICAL						PHYSICAL					
		Compressor		Fan Motor Full Load Amperes (FLA)	Minimum Circuit Ampacity Amperes	Fuse or HACR Circuit Breaker		Outdoor Coil			Refrig. Per Circuit Oz. [g]	Weight	
		Rated Load Amperes (RLA)	Locked Rotor Amperes (LRA)			Minimum Amperes	Maximum Amperes	Face Area Sq. Ft. [m ²]	No. Rows	CFM [L/s]		Net Lbs. [kg]	Shipping Lbs. [kg]
Rev. 3/11/2010													
018JEZ	1-60-208/230	9/9	48	1.9	14/14	20/20	20/20	11 [1.02]	1	1955 [923]	82 [2325]	145.5 [66]	160.5 [72.8]
024JEZ	1-60-208/230	13.5/13.5	58.3	1.1	18/18	25/25	30/30	20 [1.86]	1	3295 [1555]	128 [3629]	199.5 [90.5]	214.5 [97.3]
030JEZ	1-60-208/230	12.8/12.8	64	1.9	18/18	25/25	30/30	20 [1.86]	1	3645 [1720]	129 [3657]	201 [91.2]	214 [97.1]
036JEZ	1-60-208/230	16/16	79	1.9	22/22	30/30	35/35	23.01 [2.14]	1	3680 [1737]	146 [4139]	205 [93]	227 [103]
042JEZ	1-60-208/230	17.9/17.9	112	2.8	26/26	30/30	40/40	23.01 [2.14]	1	3925 [1852]	152 [4309]	234 [106.1]	256 [116.1]
048JEZ	1-60-208/230	21.8/21.8	117	2.8	31/31	40/40	50/50	23.01 [2.14]	2	3685 [1739]	203 [5755]	273 [123.8]	298 [135.2]
056JEZ	1-60-208/230	21.4/21.4	135	2.8	30/30	35/35	50/50	23 [2.14]	2	3685 [1739]	255 [7229]	281.5 [127.7]	306.5 [139]
060JEZ	1-60-208/230	26.4/26.4	134	2.8	36/36	45/45	60/60	23 [2.14]	2	4350 [2053]	262 [7428]	281.5 [127.7]	306.5 [139]

NOTE: Factory refrigerant charge includes refrigerant for 15 feet of standard line set.

WARNING

THE MANUFACTURER'S WARRANTY DOES NOT COVER ANY DAMAGE OR DEFECT TO THE AIR CONDITIONER CAUSED BY THE ATTACHMENT OR USE OF ANY COMPONENTS, ACCESSORIES OR DEVICES (OTHER THAN THOSE AUTHORIZED BY THE MANUFACTURER) INTO, ONTO OR IN CONJUNCTION WITH THE AIR CONDITIONER. YOU SHOULD BE AWARE THAT THE USE OF UNAUTHORIZED COMPONENTS, ACCESSORIES OR DEVICES MAY ADVERSELY AFFECT THE OPERATION OF THE AIR CONDITIONER AND MAY ALSO ENDANGER LIFE AND PROPERTY. THE MANUFACTURER DISCLAIMS ANY RESPONSIBILITY FOR SUCH LOSS OR INJURY RESULTING FROM THE USE OF SUCH UNAUTHORIZED COMPONENTS, ACCESSORIES OR DEVICES.

MATCH ALL COMPONENTS:

- OUTDOOR UNIT
- INDOOR COIL/METERING DEVICE
- INDOOR AIR HANDLER/FURNACE
- REFRIGERANT LINES

GENERAL

The information contained in this manual has been prepared to assist in the proper installation, operation and maintenance of the air conditioning system. Improper installation, or installation not made in accordance with these instructions, can result in unsatisfactory operation, noise or component failures, and/or dangerous conditions, and can cause the related warranty not to apply.

Read this manual and any instructions packaged with separate equipment required to make up the system prior to installation. Retain this manual for future reference.

To achieve optimum efficiency and capacity, the indoor cooling coils listed in the condensing unit specification sheet should be used.

IMPORTANT: We recommend replacement of any HVAC equipment that has been subjected to flooding in order to avoid any risk of injury or harm.

IMPORTANT: Use all available safety precautions during the installation and servicing of any HVAC equipment.

APPLICATION

Before installing any air conditioning equipment, a duct analysis of the structure and a heat gain calculation must be made. A heat gain calculation begins by measuring all external surfaces and openings that gain heat from the surrounding air and quantifying that heat gain. A heat gain calculation also calculates the extra heat load caused by sunlight and by humidity removal.

There are several factors that the installers must consider:

- Outdoor unit location
- System refrigerant charge
- Indoor unit blower speed
- System air balancing
- Proper equipment evacuation
- Indoor unit airflow
- Supply and return air duct design and sizing
- Diffuser and return air grille location and sizing

LOCATING UNIT

CONDENSER LOCATION

Consult local and national building codes and ordinances for special installation requirements. Following location information will provide longer life and simplified servicing of the outdoor condenser.

NOTE: These units must be installed outdoors. No ductwork can be attached, or other modifications made, to the discharge grille. Modifications will affect performance or operation.

OPERATIONAL ISSUES

- **IMPORTANT:** Locate the condenser in a manner that will not prevent, impair or compromise the performance of other equipment horizontally installed in proximity to the unit. Maintain all required minimum distances to gas and electric meters, dryer vents, any exhaust and inlet openings. In the absence of National Codes, or manufacturers' recommendations, local code recommendations and requirements will take precedence.
- Refrigerant piping and wiring should be properly sized and kept as short as possible to avoid capacity losses and increased operating costs.
- Locate the condenser where water run off will not create a problem with the equipment. Position the unit away from the drip edge of the roof whenever possible. Units are weatherized, but can be affected by water pouring into the unit from the junction of rooflines without protective guttering.

FOR CONDENSERS WITH SPACE LIMITATIONS

In the event that a space limitation exists, we will permit the following clearances:

Single Unit Applications: One condenser inlet air grille side may be reduced to no less than a 6-inch clearance. Clearances below 6 inches will reduce unit capacity and efficiency. Do not reduce the 60-inch discharge, or the 24-inch service clearances.

Multiple Unit Applications: When multiple condenser grille sides are aligned, a 6-inch per unit clearance is recommended, for a total of 12" between two units. Two combined clearances below 12 inches will reduce capacity and efficiency. Do not reduce the 60-inch discharge, or 24-inch service, clearances.

CUSTOMER SATISFACTION ISSUES

NOTE: In some cases, noise in the living area has been traced back to improper installation of equipment.

- The condenser should be located away from the living, sleeping and recreational spaces of the owner and those spaces on adjoining property.
- Avoid direct contact with water pipes, ductwork, floor joists, wall studs, floors and walls when installing refrigerant tubing. Do not suspend refrigerant tubing from joists or wall studs. When necessary, use hanger straps to secure refrigerant tubing to insulation.
- To prevent noise transmission, the mounting pad for the outdoor unit should not be connected to the structure, and should be located sufficient distance above grade to prevent ground water from entering the unit.

CORROSIVE ENVIRONMENT

The metal parts of this unit may be subject to rust or deterioration if exposed to a corrosive environment. This oxidation could shorten the equipment's useful life. Corrosive elements include, but are not limited to, salt spray, fog or mist in seacoast areas, sulphur or chlorine from lawn watering systems, swimming pools, and various chemical contaminants from industries such as paper mills and petroleum refineries.

If the unit is to be installed in an area where contaminants are likely to be a problem, special attention should be given to the equipment location and exposure.

- Avoid having lawn sprinkler heads spray directly on the unit cabinet.
- In coastal areas, locate the unit on the side of the building away from the waterfront.
- Shielding provided by a fence or shrubs may give some protection, but cannot violate minimum airflow and service access clearances.
- Elevating the unit off its slab or base enough to allow air circulation will help avoid holding water against the basepan.

Regular maintenance will reduce the build-up of contaminants and help to protect the unit's finish.

WARNING

DISCONNECT ALL POWER TO UNIT BEFORE STARTING MAINTENANCE. FAILURE TO DO SO CAN CAUSE ELECTRICAL SHOCK RESULTING IN SEVERE PERSONAL INJURY OR DEATH.

- Frequent washing of the cabinet, fan blade and coil with fresh water will remove most of the salt or other contaminants that build up on the unit.
- Regular cleaning and waxing of the cabinet with an automobile polish will provide some protection.
- A liquid cleaner may be used several times a year to remove matter on the cabinet that will not wash off with water.

Several different types of protective coil-coatings are offered in some areas. These coatings may provide some benefit, but the effectiveness of such coating materials cannot be verified by the equipment manufacturer.

PROPER INSTALLATION

Proper sizing and installation of equipment is critical to achieve optimal performance. Use the information in this Installation Instruction Manual and reference the applicable Engineering Specification Sheet when installing this product.

IMPORTANT: This product has been designed and manufactured to meet ENERGY STAR® criteria for energy efficiency when matched with appropriate coil components. However, proper refrigerant charge and proper air flow are critical to achieve rated capacity and efficiency. Installation of this product should follow the manufacturer's refrigerant charging and air flow instructions. **Failure to confirm proper charge and airflow may reduce energy efficiency and shorten equipment life.**

UNIT MOUNTING

If elevating the condensing unit, either on a flat roof or on a slab, observe the following guidelines.

- The base pan provided elevates the condenser coil 3/4" above the base pad.
- If elevating a unit on a flat roof, use 4" x 4" (or equivalent) stringers positioned to distribute unit weight evenly and prevent noise and vibration.

NOTE: Do not block drain openings shown in Figure 1.

FACTORY-PREFERRED TIE-DOWN METHOD FOR OUTDOOR UNITS

IMPORTANT: The Manufacturer approved/recommended method is a guide to securing equipment for wind and seismic loads. Other methods might provide the same result, but the Manufacturer method is the only one endorsed by Manufacturer for securing equipment where wind or earthquake damage can occur. Additional information is available in the PTS (Product Technical Support) section of the Manufacturer website Rheemote.net and can be found as a listing under each outdoor model. If you do not have access to this site, your Distributor can offer assistance.

REFRIGERANT CONNECTIONS

All units are factory charged with Refrigerant R-410A. All models are supplied with service valves. Keep tube ends sealed until connection is to be made to prevent system contamination.

TOOLS REQUIRED FOR INSTALLING & SERVICING R-410A MODELS

Manifold Sets:

- Up to 800 PSIG High Side
- Up to 250 PSIG Low Side
- 550 PSIG Low Side Retard

Manifold Hoses:

- Service Pressure Rating of 800 PSIG

Recovery Cylinders:

- 400 PSIG Pressure Rating
- Dept. of Transportation 4BA400 or BW400

 CAUTION
--

R-410A systems operate at higher pressures than R-22 systems. Do not use R-22 service equipment or components on R-410A equipment.

SPECIFICATION OF R-410A:

Application: R-410A is not a drop-in replacement for R-22; equipment designs must accommodate its higher pressures. It cannot be retrofitted into R-22 condensing units.

Physical Properties: R-410A has an atmospheric boiling point of -62.9°F and its saturation pressure at 77°F is 224.5 psig.

Composition: R-410A is an azeotropic mixture of 50% by weight difluoromethane (HFC-32) and 50% by weight pentafluoroethane (HFC-125).

Pressure: The pressure of R-410A is approximately 60% (1.6 times) greater than R-22. Recovery and recycle equipment, pumps, hoses and the like need to have design pressure ratings appropriate for R-410A. *Manifold sets need to range up to 800 psig high-side and 250 psig low-side with a 550 psig low-side retard. Hoses need to have a service pressure rating of 800 psig. Recovery cylinders need to have a 400 psig service pressure rating. DOT 4BA400 or DOT BW400.*

Combustibility: At pressures above 1 atmosphere, mixture of R-410A and air can become combustible. R-410A and air should never be mixed in tanks or supply lines, or be allowed to accumulate in storage tanks. Leak checking should never be done with a mixture of R-410A and air. Leak checking can be performed safely with nitrogen or a mixture of R-410A and nitrogen.

QUICK REFERENCE GUIDE FOR R-410A

- R-410A refrigerant operates at approximately 60% higher pressure (1.6 times) than R-22. Ensure that servicing equipment is designed to operate with R-410A.
- R-410A refrigerant cylinders are pink in color.
- R-410A, as with other HFC's is only compatible with POE oils.
- Vacuum pumps will not remove moisture from oil.
- R-410A systems are to be charged with liquid refrigerants. Prior to March 1999, R-410A refrigerant cylinders had a dip tube. These cylinders should be kept upright for equipment charging. Post March 1999 cylinders do not have a dip tube and should be inverted to ensure liquid charging of the equipment.
- Do not install a suction line filter drier in the liquid line.
- A liquid line filter drier is standard on every unit. Only manufacturer approved liquid line filter driers can be used. These are Sporlan (CW083S) and Alco (80K083S) driers. These filter driers are rated for minimum working pressure of 600 psig.
- Desiccant (drying agent) must be compatible for POE oils and R-410A.

REPLACEMENT UNITS

For new and replacement units, a liquid line filter drier should be installed and refrigerant tubing should be properly sized. To prevent failure of a new condensing unit, the existing evaporator tubing system must be correctly sized and cleaned or replaced. Care must be exercised that the expansion device is not plugged. Test the oil for acid. If positive, a suction line filter drier is mandatory.

EVAPORATOR COIL

REFER TO EVAPORATOR COIL MANUFACTURER'S INSTALLATION INSTRUCTIONS.

IMPORTANT: The manufacturer is not responsible for the performance and operation of a mismatched system, or for a match listed with another manufacturer's coil.

NOTE: All (-)ANL and (-)APM units must be installed with a TEV Evaporator.

The thermostat expansion valve is specifically designed to operate with R-410A. **DO NOT use an R-22 TEV or evaporator. The existing evaporator must be replaced with the factory specified TEV evaporator specifically designed for R-410A.**

LOCATION

Do not install the indoor evaporator coil in the return duct system of a gas or oil furnace. Provide a service inlet to the coil for inspection and cleaning. Keep the coil pitched toward the drain connection.

INTERCONNECTING TUBING

CAUTION

When coil is installed over a finished ceiling and/or living area, it is recommended that a secondary sheet metal condensate pan be constructed and installed under entire unit. Failure to do so can result in property damage.

VAPOR AND LIQUID LINES

Keep all lines sealed until connection is made.

Make connections at the indoor coil first.

Refer to Line Size Information in Tables 4 and 5 for correct size and multipliers to be used to determine capacity for various vapor line diameters and lengths of run. The losses due to the lines being exposed to outdoor conditions are not included.

The factory refrigeration charge in the outdoor unit is sufficient for the unit and 15 feet of standard size interconnecting liquid and vapor lines. For different lengths, adjust the charge as indicated below.

1/4" ± 0.2 oz. per foot

5/16" ± 0.3 oz. per foot

3/8" ± 0.5 oz. per foot

1/2" ± 1.0 oz. per foot

MAXIMUM LENGTH OF LINES

The maximum length of interconnecting line is 150 feet. Always use the shortest length possible with a minimum number of bends. Additional compressor oil is not required for any length up to 150 feet.

NOTE: Excessively long refrigerant lines cause loss of equipment capacity.

OUTDOOR UNIT INSTALLED ABOVE INDOOR COIL

Keep the vertical separation between coils to a minimum. However, the vertical distance can be as great as 120 feet with the condensing unit ABOVE the indoor coil. Use the following guidelines when installing the unit:

1. DO NOT exceed 120 feet maximum vertical separation.
2. Expansion Valve Coil:
 - a. The vertical separation can be greater than the value in Table 4, but no more than 120 feet.
 - b. No changes are required for expansion valve coils.
3. Always use the smallest liquid line size permitted to minimize the system charge.
4. Table 4 may be used for sizing horizontal runs.

OUTDOOR UNIT BELOW INDOOR COIL

Keep the vertical separation to a minimum. Use the following guidelines when installing the unit:

1. DO NOT exceed the vertical separations as indicated on Table 5.
2. Always use the smallest liquid line size permitted to minimize system charge.
3. No changes are required for either flow check piston coils or expansions coils.
4. Table 4 may be used for sizing horizontal runs.

TABLE 3
ELBOW EQUIVALENT LENGTHS, FT.

Size	Short Radius	Long Radius
1/4	0.4	0.2
5/16	0.5	0.3
3/8	0.5	0.3
1/2	0.6	0.4
5/8	0.8	0.6
3/4	0.9	0.8
7/8	1.0	1.0
1-1/8	1.2	1.2
1-3/8	2.1	1.4
1-5/8	2.5	1.5

TUBING INSTALLATION

Observe the following when installing correctly sized type “L” refrigerant tubing between the condensing unit and evaporator coil:

- If a portion of the liquid line passes through a hot area where liquid refrigerant can be heated to form vapor, insulating the liquid line is required.
- Use clean, dehydrated, sealed refrigeration grade tubing.
- Always keep tubing sealed until tubing is in place and connections are to be made.
- Blow out the liquid and vapor lines with dry nitrogen before connecting to the outdoor unit and indoor coil. For an air conditioning system, any debris in the line set could end up plugging the expansion device.
- As an added precaution, a high quality filter drier shipped with unit, is recommended to be installed in the liquid line.
- If tubing has been cut, make sure ends are deburred while holding in a position to prevent chips from falling into tubing. Burrs such as those caused by tubing cutters can affect performance dramatically, particularly on small liquid line sizes.
- For best operation, keep tubing run as short as possible with a minimum number of elbows or bends.
- Locations where the tubing will be exposed to mechanical damage should be avoided. If it is necessary to use such locations, the copper tubing should be housed to prevent damage.
- If tubing is to be run underground, it must be run in a sealed watertight chase.
- Use care in routing tubing and do not kink or twist. Use a good tubing bender on the vapor line to prevent kinking.
- The vapor line must be insulated to prevent dripping (sweating) and prevent performance losses. Armaflex and Rubatex are satisfactory insulations for this purpose. Use 1/2” minimum insulation thickness, additional insulation may be required for long runs.
- Check Table 4 for the correct vapor line size. Check Table 5 for the correct liquid line size.

TUBING CONNECTIONS

Indoor evaporator coils have only a holding charge of dry nitrogen. Keep all tube ends sealed until connections are to be made.

- Use type “L” copper refrigeration tubing. Braze the connections with accepted industry practices.
- Be certain both refrigerant service valves at the outdoor unit are closed.
- Clean the fittings before brazing.
- Remove the cap and schrader core from service port to protect seals from heat damage.
- Use an appropriate heatsink material around the copper stub and the service valves before applying heat.
- **IMPORTANT:** Do not braze any fitting with the TEV sensing bulb attached.
- Braze the tubing between the outdoor unit and indoor coil. Flow dry nitrogen into a service port and through the tubing while brazing.
- After brazing – use an appropriate heatsink material to cool the joint and remove any flux residue.

LEAK TESTING

- Pressurize line set and coil through service fittings with dry nitrogen to 150 psig maximum. Leak test all joints using liquid detergent. If a leak is found, repair and repeat leak test procedures.

WARNING

DO NOT USE OXYGEN TO PURGE LINES OR PRESSURIZE SYSTEM FOR LEAK TEST. OXYGEN REACTS VIOLENTLY WITH OIL, WHICH CAN CAUSE AN EXPLOSION RESULTING IN SEVERE PERSONAL INJURY OR DEATH.

EVACUATION PROCEDURE

Evacuation is the most important part of the entire service procedure. The life and efficiency of the equipment is dependent upon the thoroughness exercised by the serviceman when evacuating air and moisture from the line set and indoor coil.

Air in the system causes high condensing temperatures and pressure, resulting in increased power input and non-verifiable performance.

Moisture chemically reacts with the refrigerant and oil to form corrosive hydrofluoric and hydrochloric acids. These attack motor windings and parts, causing breakdown.

After the system has been leak checked and proven sealed, connect the vacuum pump and evacuate system to 500 microns. The vacuum pump must be connected to both the high and low sides of the system through adequate connections. Use the largest size connections available since restrictive service connections may lead to false readings because of pressure drop through the fittings.

IMPORTANT: Compressors (especially scroll type) should never be used to evacuate the air conditioning system because internal electrical arcing may result in a damaged or failed compressor.

START UP AND PERFORMANCE

Even though the unit is factory charged with Refrigerant 410A, the charge must be checked to the charge table attached to the service panel and adjusted, if required. Allow a minimum of 5 minutes running. Before analyzing charge, see the instructions on the unit service panel rating plate for marking the total charge.

- The service valves are not backseating valves. To open the valves, remove the valve cap with an adjustable wrench. Insert a 3/16" or 5/16" hex wrench into the stem. Back out counterclockwise until it stops.
- Replace the valve cap finger tight then tighten an additional 1/8 of a turn for a metal-to-metal seal.

TABLE 4
SUCTION LINE LENGTH/SIZE VS. CAPACITY MULTIPLIER (R410A)

UNIT SIZE		1½ Ton	2 Ton	2½ Ton	3 Ton	3½ Ton	4 Ton	5 Ton
Suction Line Connection Size		3/4" [19] I.D.	3/4" [19] I.D.	3/4" [19] I.D.	3/4" [19] I.D.	7/8" [22.2] I.D.	7/8" [22.2] I.D.	7/8" [22.2] I.D.
Suction Line Run - Feet [m]		5/8" [15.9]	5/8" [15.9]	5/8" [15.9]	—	3/4" [19]	—	—
		3/4" [19]*	3/4" [19]*	3/4" [19]*	3/4" [19]*	7/8" [22.2]*	7/8" [22.2]*	7/8" [22.2]*
		—	—	7/8" [22.2]	7/8" [22.2]	—	1 1/8" [28.6]	1 1/8" [28.6]
25' [7.6]	Optional	1.00	1.00	1.00	—	1.00	—	—
	Standard	1.00	1.00	1.00	1.00	1.00	1.00	1.00
	Optional	—	—	1.00	1.00	—	1.00	1.00
50' [15.24]	Optional	0.98	0.98	0.96	—	0.99	—	—
	Standard	0.99	0.99	0.98	0.98	0.99	0.99	0.99
	Optional	—	—	0.99	0.99	—	0.99	0.99
100' [30.5]	Optional	0.95	0.95	0.94	—	0.96	—	—
	Standard	0.96	0.96	0.96	0.96	0.98	0.96	0.97
	Optional	—	—	0.97	0.97	—	0.98	0.98
150' [45.7]	Optional	0.92	0.92	0.91	—	0.94	—	—
	Standard	0.93	0.94	0.93	0.94	0.96	0.95	0.94
	Optional	—	—	0.95	0.95	—	0.96	0.97

NOTES:
*Standard

[] Designates Metric Conversions

Note: Using suction line larger than shown in chart will result in poor oil return and is not recommended.

TABLE 5
LIQUID LINE SIZE – OUTDOOR UNIT ABOVE INDOOR COIL

System Capacity	Line Size Connection Size (Inch I.D.) [mm]	Line Size (Inch I.D.) [mm]	Liquid Line Size Outdoor Unit Above Indoor Coil (Cooling Only - Does not apply to Heat Pumps)					
			Total Line Length - Feet [m] ("0" means no restrictions)					
			25 [7.6]	50 [15.2]	75 [22.9]	100 [30.5]	125 [38.1]	150 [45.7]
			Minimum Vertical Separation - Feet [m]					
1½ Ton	3/8" [9.5]	1/4 [6.4]	0	0	0	0	8 [2.4]	24 [7.3]
		5/16 [7.9]	0	0	0	0	0	0
		3/8* [9.5]	0	0	0	0	0	0
2 Ton	3/8" [9.5]	1/4 [6.4]	0	3 [0.9]	29 [8.8]	55 [16.8]	81 [24.7]	108 [32.9]
		5/16 [7.9]	0	0	0	0	0	0
		3/8* [9.5]	0	0	0	0	0	0
2½ Ton	3/8" [9.5]	1/4 [6.4]	0	14 [4.3]	56 [17.1]	98 [29.9]	N/A	N/A
		5/16 [7.9]	0	0	0	0	0	0
		3/8* [9.5]	0	0	0	0	0	0
3 Ton	3/8" [9.5]	5/16 [7.9]	0	0	0	0	0	0
		3/8* [9.5]	0	0	0	0	0	0
3½ Ton	3/8" [9.5]	5/16 [7.9]	0	0	0	16 [4.9]	35 [10.7]	54 [16.5]
		3/8* [9.5]	0	0	0	0	0	0
4 Ton	3/8" [9.5]	5/16 [7.9]	0	0	0	0	0	0
		3/8* [9.5]	0	0	0	0	0	0
5 Ton	3/8" [9.5]	5/16 [7.9]	0	0	0	0	0	0
		3/8* [9.5]	0	0	0	0	0	0
System Capacity	Line Size Connection Size (Inch I.D.) [mm]	Line Size (Inch O.D.) [mm]	Liquid Line Size Outdoor Unit Below Indoor Coil					
			Total Line Length - Feet [m]					
			25 [7.6]	50 [15.2]	75 [22.9]	100 [30.5]	125 [38.1]	150 [45.7]
			Maximum Vertical Separation - Feet [m]					
1½ Ton	3/8" [9.5]	1/4 [6.4]	25 [7.6]	40 [12.1]	25 [7.6]	9 [2.7]	N/A	N/A
		5/16 [7.9]	25 [7.6]	50 [15.2]	62 [18.9]	58 [17.7]	53 [16.2]	49 [14.9]
		3/8* [9.5]	25 [7.6]	50 [15.2]	75 [22.9]	72 [21.9]	70 [21.3]	68 [20.7]
2 Ton	3/8" [9.5]	1/4 [6.4]	25 [7.6]	N/A	N/A	N/A	N/A	N/A
		5/16 [7.9]	25 [7.6]	36 [10.9]	29 [8.8]	23 [7.0]	16 [4.9]	9 [2.7]
		3/8* [9.5]	25 [7.6]	50 [15.2]	72 [21.9]	70 [21.3]	68 [20.7]	65 [19.8]
2½ Ton	3/8" [9.5]	1/4 [6.4]	25 [7.6]	N/A	N/A	N/A	N/A	N/A
		5/16 [7.9]	25 [7.6]	49 [14.9]	38 [11.6]	27 [8.3]	17 [5.2]	6 [1.8]
		3/8* [9.5]	25 [7.6]	50 [15.2]	68 [20.7]	65 [19.8]	62 [18.9]	58 [17.7]
3 Ton	3/8" [9.5]	5/16 [7.9]	25 [7.6]	50 [15.2]	37 [11.3]	22 [6.7]	7 [2.1]	N/A
		3/8* [9.5]	25 [7.6]	50 [15.2]	68 [20.7]	63 [19.2]	58 [17.7]	53 [16.2]
3½ Ton	3/8" [9.5]	5/16 [7.9]	25 [7.6]	23 [7.0]	4 [1.2]	N/A	NA	N/A
		3/8* [9.5]	25 [7.6]	50 [15.2]	43 [13.1]	36 [10.9]	30 [9.1]	24 [7.3]
4 Ton	3/8" [9.5]	5/16 [7.9]	25 [7.6]	46 [14.0]	38 [11.6]	30 [9.1]	22 [6.7]	15 [4.5]
		3/8* [9.5]	25 [7.6]	50 [15.2]	56 [17.1]	55 [16.8]	53 [16.2]	52 [15.8]
5 Ton	3/8" [9.5]	5/16 [7.9]	25 [7.6]	50 [15.2]	56 [17.1]	44 [13.4]	32 [9.8]	20 [6.1]
		3/8* [9.5]	25 [7.6]	50 [15.2]	75 [22.9]	81 [24.7]	79 [24.1]	76 [23.2]

NOTES:

*Standard

N/A = Application not recommended.

[] Designates Metric Conversions

CHECKING AIRFLOW

The air distribution system has a drastic effect on the life and performance of a system. The duct system is totally controlled by the contractor. For this reason, the contractor should use only industry-recognized procedures to design and construct duct system.

The correct air quantity is critical to air conditioning systems. Proper operation, efficiency, compressor life, and humidity control depend on the correct balance between indoor load and outdoor unit capacity. Excessive indoor airflow increases the possibility of high humidity problems. Low indoor airflow reduces total capacity, and causes coil icing. Serious harm can be done to the compressor by low airflow, such as that caused by refrigerant flooding.

Air conditioning systems require a specified airflow. Each ton of cooling requires between 350 and 450 cubic feet of air per minute (CFM), or 400 CFM nominally.

Duct design and construction should be carefully done. System performance can be lowered dramatically through bad planning or workmanship.

Air supply diffusers must be selected and located carefully. They must be sized and positioned to deliver treated air along the perimeter of the space. If they are too small for their intended airflow, they become noisy. If they are not located properly, they cause drafts. Return air grilles must be properly sized to carry air back to the blower. If they are too small, they also cause noise.

The installers should balance the air distribution system to ensure proper quiet airflow to all rooms in the home. This ensures a comfortable living space.

These simple mathematical formulas can be used to determine the CFM in a residential or light commercial system.

Electric resistance heaters can use

$$\text{CFM} = \frac{\text{volts} \times \text{amps} \times 3.414}{1.08 \times \text{temp rise}}$$

Gas furnaces can use

$$\text{CFM} = \frac{\text{BTUH}}{\Delta T \times 1.08}$$

An air velocity meter or airflow hood can give a more accurate reading of the system CFM.

CHECKING REFRIGERANT CHARGE

Charge for all systems should be checked against the Charging Chart inside the access panel cover. Before using the chart, the indoor conditions must be within 2°F of desired comfort conditions and system must be run until operating conditions stabilize (15 min. to 30 min.)

CAUTION

THE TOP OF THE SCROLL COMPRESSOR SHELL IS HOT. TOUCHING THE COMPRESSOR TOP MAY RESULT IN SERIOUS PERSONAL INJURY.

IMPORTANT: Do not operate the compressor without charge in system.

Addition of R-410A will raise pressures (vapor, liquid and discharge) and lower vapor temperature.

If adding R-410A raises both vapor pressure and temperature, the unit is overcharged.

IMPORTANT: Use industry-approved charging methods to ensure proper system charge.

CHARGING BY LIQUID PRESSURE

Liquid pressure method is used for charging systems in the cooling mode when an expansion valve is used on the evaporator. The service port on the liquid service valve (small valve) is used for this purpose.

Read and record the outdoor ambient temperature entering the condensing unit, and the liquid line pressure at the service valve (the small valve). Locate the charging chart attached to the unit. The correct liquid line pressure will be found by finding the intersection of the unit model size and the outdoor ambient temperature. Adjust the liquid line pressure by either adding refrigerant to raise pressure or removing refrigerant to lower pressure.

CHARGING UNITS WITH R-410A REFRIGERANT

Checking the charge, or charging units using R-410A refrigerant, differs from those with R-22. The following procedures apply to units with R-410A refrigerant. These procedures require outdoor ambient temperature, liquid line pressure and indoor wet bulb temperature be used.

IMPORTANT: ONLY ADD LIQUID REFRIGERANT CHARGE INTO THE SUCTION LINE WITH R-410A UNITS. USE A COMMERCIAL METERING DEVICE TO ADD CHARGE INTO THE SUCTION LINE WITHOUT DAMAGE TO THE COMPRESSOR.

1. Read and record the outdoor ambient temperature entering the condensing unit.
2. Read and record the liquid line pressure at the small service valve.
3. Read and record the indoor ambient wet bulb temperature entering the indoor coil.
4. Use the appropriate charging chart to compare the actual liquid pressure to the correct pressure as listed on the chart.
5. R-410A charging charts are listed on the unit.

CAUTION

R-410A PRESSURES ARE APPROXIMATELY 60% HIGHER THAN R-22 PRESSURES. USE APPROPRIATE CARE WHEN USING THIS REFRIGERANT. FAILURE TO EXERCISE CARE MAY RESULT IN EQUIPMENT DAMAGE, OR PERSONAL INJURY.

CHARGING BY WEIGHT

For a new installation, evacuation of interconnecting tubing and evaporator coil is adequate; otherwise, evacuate the entire system. Use the factory charge shown in Table 1 of these instructions or unit data plate. Note that charge value includes charge required for 15 ft. of standard size interconnecting liquid line. Calculate actual charge required with installed liquid line size and length using:

- 1/4" O.D. = 0.2 oz./ft.
- 5/16" O.D. = 0.3 oz./ft.
- 3/8" O.D. = 0.5 oz./ft.
- 1/2" O.D. = 1.0 oz./ft.

With an accurate scale (+/- 1 oz.) or volumetric charging device, adjust charge difference between that shown on the unit data plate and that calculated for the new system installation. If the entire system has been evacuated, add the total calculated charge.

NOTE: When the total refrigerant charge volume exceeds the values in Tables 6 and 7, the manufacturer recommends installing a crankcase heater and start kit.

TABLE 6
MAXIMUM SYSTEM CHARGE VALUES (-)ANL

(-)ANL Model Size	Compressor Model Number	Charge Limit Without Crankcase Heat (3 Phase)	Charge Limit Without Crankcase Heat (1 Phase)
18	ZP16K5E	8 lbs.	9.6 lbs.
24	ZP21K5E	8 lbs.	9.6 lbs.
31	ZP25K5E	8 lbs.	9.6 lbs.
37	ZP34K5E	10 lbs.	12 lbs.
43	ZP38K5E	10 lbs.	12 lbs.
49	ZP42K5E	10 lbs.	12 lbs.
60	ZP54K5E	10 lbs.	12 lbs.

TABLE 7
MAXIMUM SYSTEM CHARGE VALUES (-)APM

(-)APM Model Size	Compressor Model Number	Charge Limit Without Crankcase Heat (1 Phase)
18	ZP16K5E	9.6 lbs.
24	ZP20K5E	9.6 lbs.
30	ZP24K5E	9.6 lbs.
36	ZP31K5E	9.6 lbs.
42	ZP34K5E	12 lbs.
48	ZP42K5E	12 lbs.
56	ZP44K5E	12 lbs.
60	ZP51K5E	12 lbs.

FINAL LEAK TESTING

After the unit has been properly evacuated and charged, a halogen leak detector should be used to detect leaks in the system. All piping within the condensing unit, evaporator, and interconnecting tubing should be checked for leaks. If a leak is detected, the refrigerant should be recovered before repairing the leak. The Clean Air Act prohibits releasing refrigerant into the atmosphere.

ELECTRICAL WIRING

NOTE: Check all wiring to be sure connections are securely fastened, electrically isolated from each other and that the unit is properly grounded.

Field wiring must comply with the National Electric Code (C.E.C. in Canada) and any applicable local code.

POWER WIRING

It is important that proper electrical power from a commercial utility is available at the condensing unit contactor. Voltage ranges for operation are shown in Table 8.

Install a branch circuit disconnect within sight of the unit and of adequate size to handle the starting current (see Tables 1 and 2).

TABLE 8
VOLTAGE RANGES (60 HZ)

Nameplate Voltage	Operating Voltage Range at Copeland Maximum Load Design Conditions for Compressors
208/230 (1 Phase)	187 - 253

Power wiring must be run in a rain-tight conduit. Conduit must be run through the connector panel below the access cover (see Figure 1) and attached to the bottom of the control box.

NOTE: Connect power wiring to control located in outdoor condensing unit electrical box. (See wiring diagram attached to unit access panel.)

Check all electrical connections, including factory wiring within the unit and make sure all connections are tight.

DO NOT connect aluminum field wire to the contactor terminals.

NOTE: Only use copper wire between the circuit disconnect and unit.

⚠ WARNING

TURN OFF ELECTRIC POWER AT THE FUSE BOX OR SERVICE PANEL BEFORE MAKING ANY ELECTRICAL CONNECTIONS.

ALSO, THE GROUND CONNECTION MUST BE COMPLETED BEFORE MAKING LINE VOLTAGE CONNECTIONS. FAILURE TO DO SO CAN RESULT IN ELECTRICAL SHOCK, SEVERE PERSONAL INJURY OR DEATH.

GROUNDING

A grounding lug is provided in the control box near the control for a ground wire.

⚠ WARNING

THE UNIT MUST BE PERMANENTLY GROUNDED. FAILURE TO DO SO CAN CAUSE ELECTRICAL SHOCK RESULTING IN SEVERE PERSONAL INJURY OR DEATH.

CONTROL WIRING

(See Figure 2)

If the low voltage control wiring is run in conduit with the power supply, Class I insulation is required. Class II insulation is required if run separate. Low voltage wiring may be run through the insulated bushing provided in the 7/8 hole in the base panel, up to and attached to the pigtails from the bottom of the control box. Conduit can be run to the base panel if desired by removing the insulated bushing.

NOTE: Use No. 18 AWG solid copper wire at a minimum. If the wire length between the thermostat and the unit is more than 100 ft., use 16 AWG solid copper wire to avoid excessive voltage drop.

A thermostat and a 24 volt, 40 VA minimum transformer are required for the control circuit of the condensing unit. The furnace or the air handler transformer may be used if sufficient. Verify the correct primary voltage tap is used on the transformer.

NOTE: Reference unit wiring diagram for detailed wiring instructions.

HARD START COMPONENTS

Start components are factory installed.

Start components are required with all non-bleed expansion valve coils.

FIGURE 2
CONTROL WIRING FOR GAS OR ELECTRIC HEAT

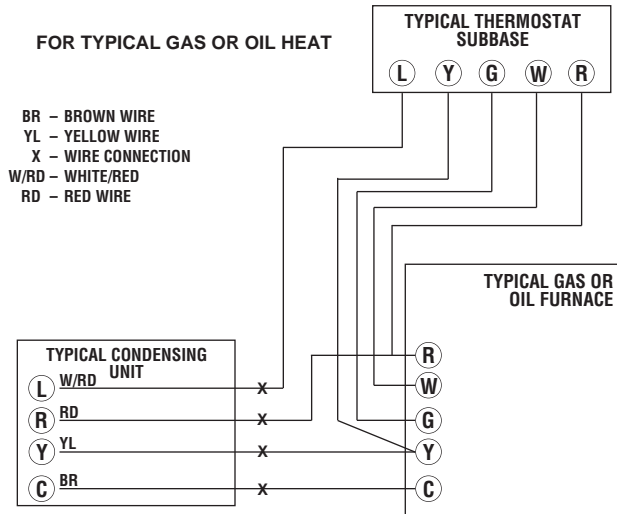

*IF MAXIMUM OUTLET TEMPERATURE RISE IS DESIRED, IT IS RECOMMENDED THAT W1 (W/BK) AND W2 (W/BL) BE JUMPERED TOGETHER.

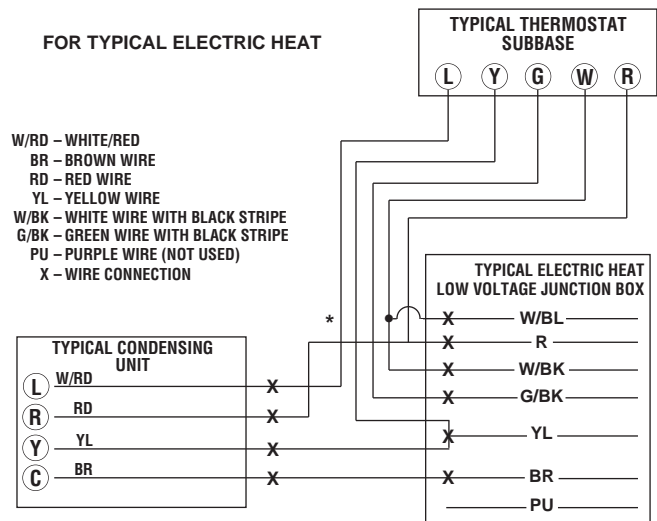

HIGH AND LOW PRESSURE CONTROLS (HPC OR LPC)

Pressure controls are factory installed.

These controls keep the compressor from operating in pressure ranges which can cause damage to the compressor. Both controls are in the low voltage control circuit.

High pressure control (HPC) is an automatic reset which opens near 610 PSIG and closes near 420 PSIG.

The low pressure control (LPC) is an automatic reset which opens near 50 PSIG and closes near 95 PSIG.

FIELD INSTALLED ACCESSORIES COMPRESSOR CRANKCASE HEAT (CCH)

While scroll compressors usually do not require crankcase heaters, there are instances when a heater should be added. Refrigerant migration during the off cycle can result in a noisy start up. Add a crankcase heater to minimize refrigeration migration, and to help eliminate any start up noise or bearing “wash out.”

NOTE: A crankcase heater should be installed if: the charge of the system exceeds the values in Tables 1 and 2, if the system is subject to voltage variations or when a low ambient control is used for system operation below 55°F.

All heaters are located on the lower half of the compressor shell. Its purpose is to drive refrigerant from the compressor shell during long off cycles, thus preventing damage to the compressor during start-up.

At initial start-up or after extended shutdown periods, make sure the heater is energized for at least 12 hours before the compressor is started. (Disconnect switch on and wall thermostat off.)

NOTE: Reference unit wiring diagram for detailed wiring instructions.

LOW AMBIENT CONTROL (LAC)

This component senses compressor head pressure and shuts the condenser fan off when the head pressure drops below designated levels. This allows the unit to build a sufficient head pressure at lower ambient in order to maintain system balance and obtain improved capacity. Low ambient control should be used on all equipment operated below 65°F ambient.

OUTDOOR UNIT COVERS

Outdoor condensing unit covers are available if the homeowner requests a cover for their unit. With the complete model number for the unit, the correct cover can be obtained through an authorized distributor.

CAUTION

FAILURE TO REMOVE CONDENSING UNIT COVER BEFORE OPERATING OUTDOOR UNIT CAN CAUSE COMPONENTS TO FAIL.

COMFORT CONTROL SYSTEM™

The Integrated Compressor Control (ICC) is an integral part of the *Comfort Control System™* and has the following features:

- Independent compressor and outdoor fan control
- Anti-short cycle protection (3 minute)
- Minimum unit run time (30 seconds)
- 7-segment LED to display status and diagnostics for faster service and accuracy
- High and low pressure switch monitoring
- Power and control voltage monitoring
- Active compressor protection integrated into the control
- Fault Recall capability with power loss memory
- Test Button allows unit operation for start-up diagnostics
- Can be used with a standard thermostat
- Flash diagnostic codes to room thermostat with L terminal
- Sealed compressor relay

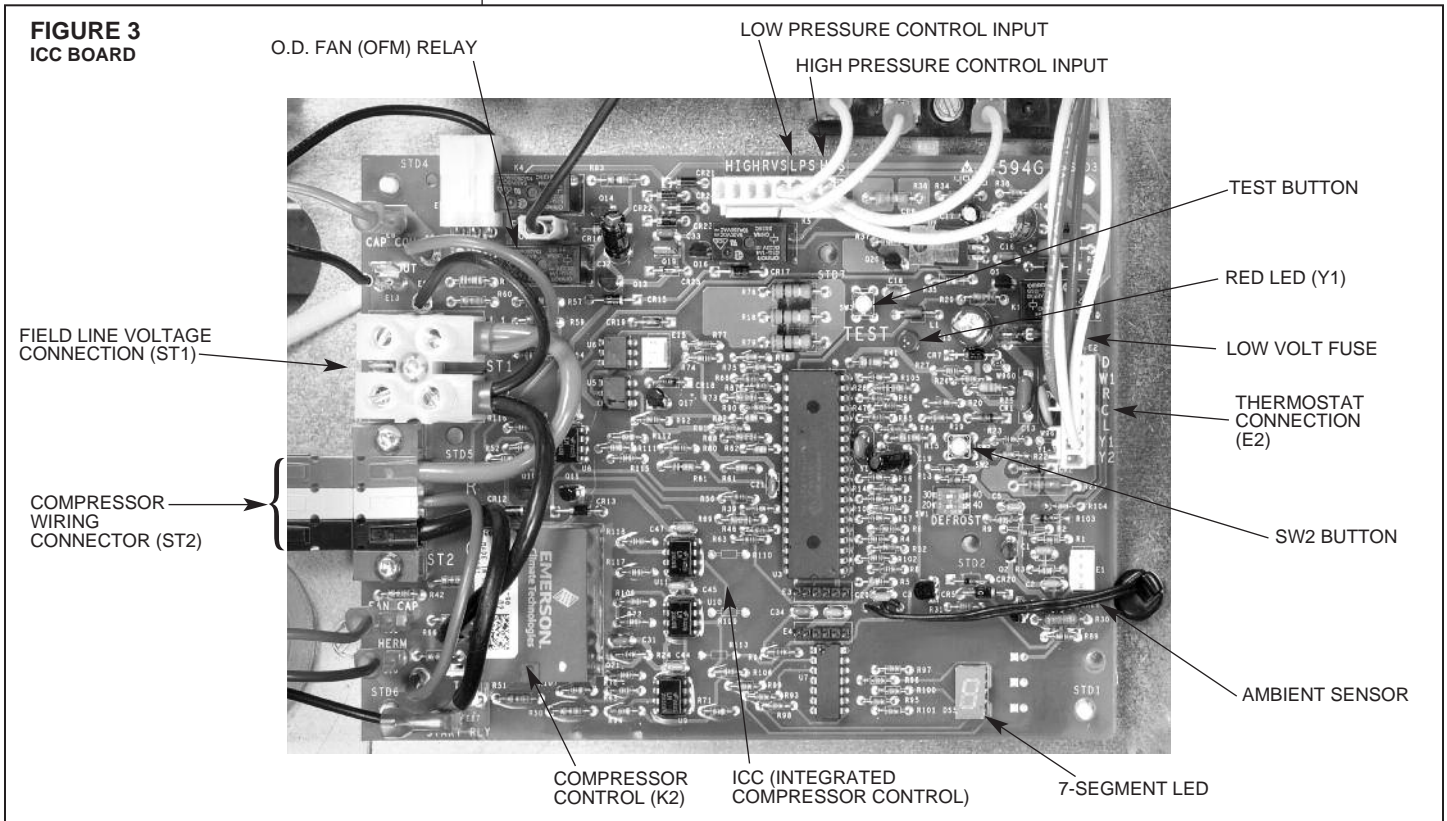

CONTROL DESCRIPTION (SEE FIGURE 3)

7-Segment LED

- Displays status and diagnostic codes (See Status and Diagnostic Description)
- Displays diagnostic/fault recall (See Test Mode/Fault Recall)

Red LED (Y1)

- Y1 red LED (solid on) indicates Y1 call from thermostat is present

⚠ CAUTION

UNIT MAY START SUDDENLY AND WITHOUT WARNING

Solid red light indicates a thermostat call for unit operation is present at the ICC control. ICC control will attempt to start unit after short cycle timer expires or when in Active Protection mode will attempt to restart unit prior to Lockout mode.

Line Voltage Connector (ST1)

- Line voltage is connected to control board at Connector ST1
- Maximum wire size accepted is 6 AWG copper wire
- Torque terminals up to 20 in. lbs. max (Check wire terminations annually)

Compressor Wiring Connectors (ST2)

- Compressor wiring assembly is factory installed (Red – Run, Yellow – Start, Black – Common)

Compressor Control (K2)

- Sealed single pole compressor relay switch with optical feedback feature (arc detection)

Thermostat Connector (E2)

- **R** – 24VAC from the indoor unit 24VAC transformer (40 VA minimum)
- **C** – 24VAC Common from the indoor unit 24VAC transformer
- **Y1** – Call for unit operation (cooling)
- **L** – Communicate/flash diagnostic codes to an indoor thermostat that is enabled with an 'L' terminal, 'check service light', or similar function

L Terminal Output

- Flash 1 – Compressor running extremely long run cycle
- Flash 2 – Low or High pressure control trip
- Flash 3 – Unit short cycling
- Flash 5 – Compressor will not run
- Flash 8 – Control mis-operation
- Flash 9 – Low control voltage

Low Volt Fuse

- If required replace with 3 A automotive ATC style blade fuse

Low Pressure Control (LPC Input – E14)

- Low-pressure control is factory installed
- Low pressure control is an automatic resetting device

High Pressure Control (HPC Input – E14)

- High-pressure control is factory installed
- High pressure control is an automatic resetting device

Ambient Temperature Sensor

- Included on control but not required in the cooling only condenser application

TEST and SW2 Buttons

- TEST and SW2 buttons used to enter Test and Fault Recall Mode

ICC CONTROL OPERATION

Installation Verification

- 24V AC power on R and C must be present at the ICC for it to operate
- Line voltage must be present at the ICC for the compressor and the outdoor fan to operate
- When line and 24VAC control voltage is present and there is no Y1 call, or other diagnostics displayed, the control will display an "O" for standby mode
- If a Y1 call is initiated within 3 minutes of unit power-up or last compressor activation the control will display a flashing "c" and the red Led will activate to solid on

Call for Operation (Y1 Call)

- The ICC has an on/off fan delay of one (1) second.
- The ICC ignores state of LPC for 90 seconds upon compressor start
- The ICC will cause the compressor to be energized for 30 seconds minimum run time except when TEST button is pushed without a Y1 call

3-minute Anti-short Cycle Timer

- The ICC has a built in 3-minute time delay between compressor operations to protect the compressor against short cycling (Status flashing c).
- The 3-minute time delay can be bypassed when a Y1 call is present by pressing the TEST button for 1 second and releasing (Status solid on c).

30 Second Minimum Run Timer

- The ICC has a built in 30 second minimum unit run time (Status flashing c).

1 Second Compressor/Fan Delay

- The ICC starts/stops the outdoor fan 1 second after the start/stop of the compressor upon a Y1 call to minimize current inrush and/or voltage droop.

Low Pressure Control (LPC)

- Upon a Y1 call, if the ICC senses an open LPC it will not allow the compressor to be energized (diagnostic code 21).
- The ICC ignores the LPC for 90 seconds after the compressor is energized.
- After 90 seconds of compressor operation (Y1), the ICC responds to the state of the LPC.
- If the LPC opens after 90 seconds of compressor run time the ICC will stop the compressor, display a 21 on the seven-segment display, and flash a 2 on L terminal output
- If there is a Y1 call the compressor will restart upon automatic resetting of the low pressure switch and the 3-minute anti short cycle timer has expired
- **Active Protection** – If the LPC opens three (3) times during the same call (Y1), the ICC will lockout the compressor to keep it from continuing to operate and flash a L21 on the seven-segment display and continue to flash a 2 on L terminal output

High Pressure Control (HPC)

- Upon Y1 call, the ICC responds to the state of the HPC.
- If the HPC opens during a Y1 call the ICC will stop the compressor, flash a 23 on the seven-segment display, and flash a 2 on L terminal output
- If there is a Y1 call the compressor will restart upon automatic resetting of the high pressure switch and the 3-minute anti short cycle timer has expired
- **Active Protection** – If the HPC opens three (3) times during the same call (Y1), the ICC will lockout the compressor to keep it from continuing to operate and flash a L23 on the seven-segment display and continue to flash a 2 on L terminal output

ACTIVE COMPRESSOR PROTECTION MODE

Active Compressor Protection

- The ICC actively protects the compressor from harmful operation during a fault condition.
- The ICC will protect the compressor by locking out if it senses three (3) trips of either low or high pressure controls during the same Y1 call (There are no additional re-tries after a pressure switch lockout)
- The ICC will de-energize the compressor if it senses a compressor fault (will try to restart the compressor for up to 6 hours before a lockout)

Exiting Active Compressor Protection Lockout

There are three methods to reset the ICC after an active protection lockout:

- Cycle line voltage to the unit
- Cycle 24VAC to the ICC (R or C connection)
- Push the TEST button down for 1 second and release (The ICC will attempt to start the unit when the **TEST** button is pressed and released)

TEST AND FAULT RECALL MODES

Test Mode (TEST Button)

- The TEST mode resets the ICC from any active protection lockout mode or bypasses the 3-minute anti-short cycle timer and energizes the unit
- To enter TEST mode press **TEST** button with an insulated probe for 1 second and then release:
 - If a Y1 call is present and a flashing “c” is indicated on the 7-segment display, a “t” will momentarily flash on the 7-segment display, the unit will energize, and the display will change to a steady “c”
 - If a Y1 call is not present a steady “t” appears on the 7-segment display and the unit will energize for a maximum of 5 seconds (times out)
- A Y1 call during TEST mode causes the ICC to exit **TEST** and enter a normal unit operation mode
- **Note:** If Y1 is present at the ICC upon exit from TEST mode the unit will continue to operate

Fault Recall Mode (TEST and SW2 Buttons)

- To enter **FAULT RECALL** mode press both **TEST** and **SW2** buttons at the same time with insulated probes for 1 second and release.
- Upon entering and exiting the **FAULT RECALL** mode, the top and bottom segments of the 7-segment display will be activated.
- The ICC control will automatically scroll through stored faults on the 7-segment display.
- Each fault is displayed one time with the top segment of the 7-segment display activated between faults.
- Each fault is displayed with the most recent fault displayed first.
- A maximum of six individual faults can be stored.
- A maximum of 3 consecutive identical faults are stored.
- A “0” will be displayed when no faults are stored.
- The ICC will automatically exit the **FAULT RECALL** mode after displaying stored faults.

Clear Fault History (TEST and SW2 Buttons)

- To clear **FAULT HISTORY** press both **TEST** and **SW2** buttons at the same time with insulated probes for 5 seconds and release.
- The top and bottom segments of the 7-segment display will be activated and flash to indicate the history has been cleared.

(*) – Indicates flash code will be an output on the ICC “L” terminal to the indoor thermostat “L” terminal. Unless a diagnostic/fault is manually cleared by cycling power or pressing the TEST button the flash code will continue at the L terminal for up to 20 seconds after the start of a successful call for unit operation.

Status and Diagnostic Description

7 -Segment Display Code	Diagnostic Description	Status / Possible Cause -Troubleshooting Information
0	Standby	Standby - No call for operation
c	Y1	First Stage or Single Stage Unit Operation
c Flashing	Anti-Short Cycle Timer (3 minutes) or Minimum Run Timer (30 seconds)	Waiting for anti-short cycle timer to expire Waiting for minimum run timer to expire
F	ICC Board Fuse Open	1. Low voltage wiring damage or miswired
1 (*)	Compressor Running Extremely Long Run Cycle (Cooling mode only)	1. Low refrigerant charge 2. Air ducts have substantial leakage 3. Check thermostat operation 4. Dirty filter 5. Dirty outdoor coil
2 (*)	Pressure Control Trip (L terminal output only)	1. (See faults 21, L21, 23, L23)
21 (***)	Low Pressure Control Trip Note: Low-pressure control is ignored for 90 seconds after call for unit operation. Active Protection – The ICC will try to restart the unit after the pressure control automatically re-closes. Unit will try to restart 3 times in the same thermostat call for operation (Y1) before lockout (fault L21).	1. Unit is low on refrigerant charge 2. Indoor coil is frozen (cooling mode) 3. Dirty indoor coil or filter (cooling mode) 4. Indoor blower is not running (cooling mode) 5. TEV is not operating correctly
L21 (**)	Lockout - Low Pressure Control Trip (**)	LPC tripped three consecutive times in same thermostat call
23 (***)	High Pressure Control Trip Active Protection – The ICC will try to restart the unit after the pressure control automatically re-closes. Unit will try to restart 3 times in the same thermostat call for operation (Y1) before lockout (fault L23)	1. Outdoor coil is dirty (cooling mode) 2. Outdoor fan is not running (cooling mode) 3. Dirty indoor coil or filter (heat pump mode) 4. Liquid line restriction (filter drier blocked, etc.) 5. Excessive refrigerant charge
L23 (**)	Lockout - High Pressure Control Trip (**)	HPC tripped three consecutive times in same thermostat call
25	Outdoor Ambient Temperature Sensor	1. ICC board sensor damaged (ICC will continue to operate)
27	Abnormal Low Line or No Line Voltage (See unit nameplate for operating voltage)	1. Check incoming line voltage to the disconnect and unit 2. Check wiring connections
28	Abnormal High Line Voltage	1. Check line voltage
3 (*)	Short Cycling	1. Check thermostat for intermittent demand signal 2. Check thermostat location in zone (too close to discharge grill)

5 (*) (***)	Compressor will not run Active Protection – After detecting compressor will not run the ICC control will shut the unit down. The control will try to restart the unit every 5 minutes for 4 tries. After that, the ICC will attempt a restart every 20 minutes up to 6 hours.	<ol style="list-style-type: none"> 1. Check for damaged, miswired, or wrong run capacitor 2. Check for damaged or miswired start capacitor and relay 3. Check voltage levels at ICC board and compressor 4. Check for broken wires, loose connectors, or miswired 5. Check compressor motor windings for continuity 6. Check for open compressor internal protector 7. Check for excessive liquid refrigerant in compressor
L5 (**)	Lockout – Check Compressor (**)	After 6 hours of attempted unit restart ICC control
-	ICC Board Mis-operation	1. Check ICC board compressor relay
8 (*)	ICC Board Mis-operation (L terminal output only)	1. Check ICC board compressor relay
9 (*)	ICC Secondary Voltage Low (Less than 18V)	1. Check transformer for miswiring or overloading.

L Terminal Output

- Flash 1 – Compressor running extremely long run cycle
- Flash 2 – Low or High pressure control trip
- Flash 3 – Unit short cycling
- Flash 5 – Compressor will not run
- Flash 8 – Control mis-operation
- Flash 9 – Low control voltage

(**) – Lockout modes are reset by either cycling line voltage, low voltage, or by pressing control **TEST** button for 1 second. The control will attempt to start the unit when the **TEST** button is pressed and released (See **TEST** button label)

(***) – **Caution: Indicates Active Protection. Unit will attempt to restart automatically.**

CAUTION

UNIT MAY START SUDDENLY AND WITHOUT WARNING

Solid red light indicates a thermostat call for unit operation is present at the ICC. ICC will attempt to start unit after short cycle timer expires or when in Active Protection mode will attempt to restart unit prior to Lockout mode.

NOTE: For Additional Questions or Comments concerning the ICC, call 1-888-923-2323.

SERVICE

SINGLE-POLE COMPRESSOR RELAY

Integrated Compressor Control Relay is a single-pole relay used on all single phase units up through 5 tons. Caution must be exercised when servicing as only one leg of the power supply is broken with the relay.

TROUBLESHOOTING

IMPORTANT: The JEZ series units with the ICC (Integrated Compressor Control) provide status and diagnostic information that greatly enhances the ability to quickly diagnose system faults. Use the following troubleshooting guides as another tool in system diagnostics.

NOTE: In diagnosing common faults in the cooling system, develop a logical thought pattern as used by experienced technicians. The charts which follow are not intended to be an answer to all problems but only to guide the technician's troubleshooting. Through a series of yes and no answers, follow the logical path to a likely conclusion.

A novice technician should use these charts like a road map. Remember that the chart should clarify a logical path to the solution.

ELECTRICAL CHECKS FLOW CHART

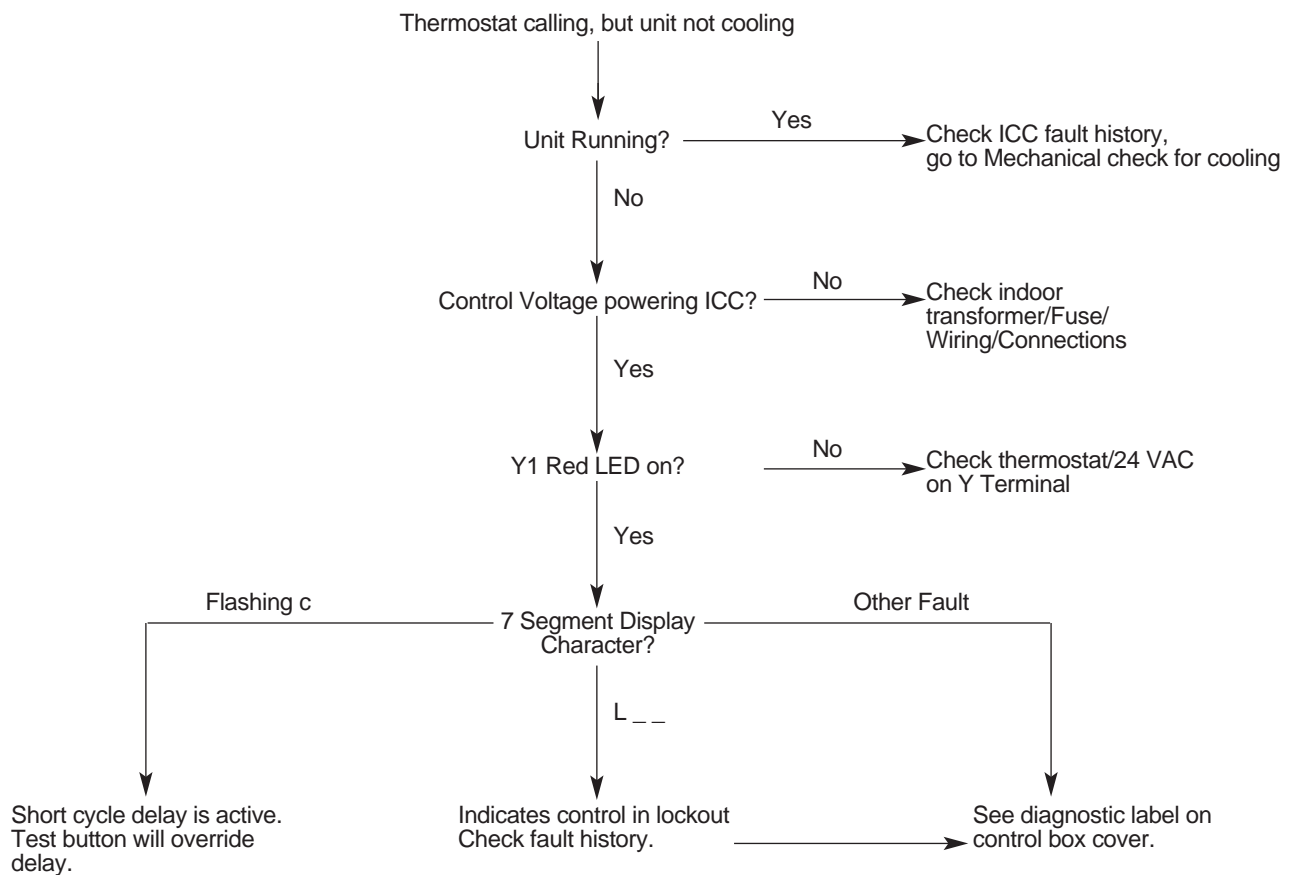

COOLING MECHANICAL CHECKS FLOW CHART

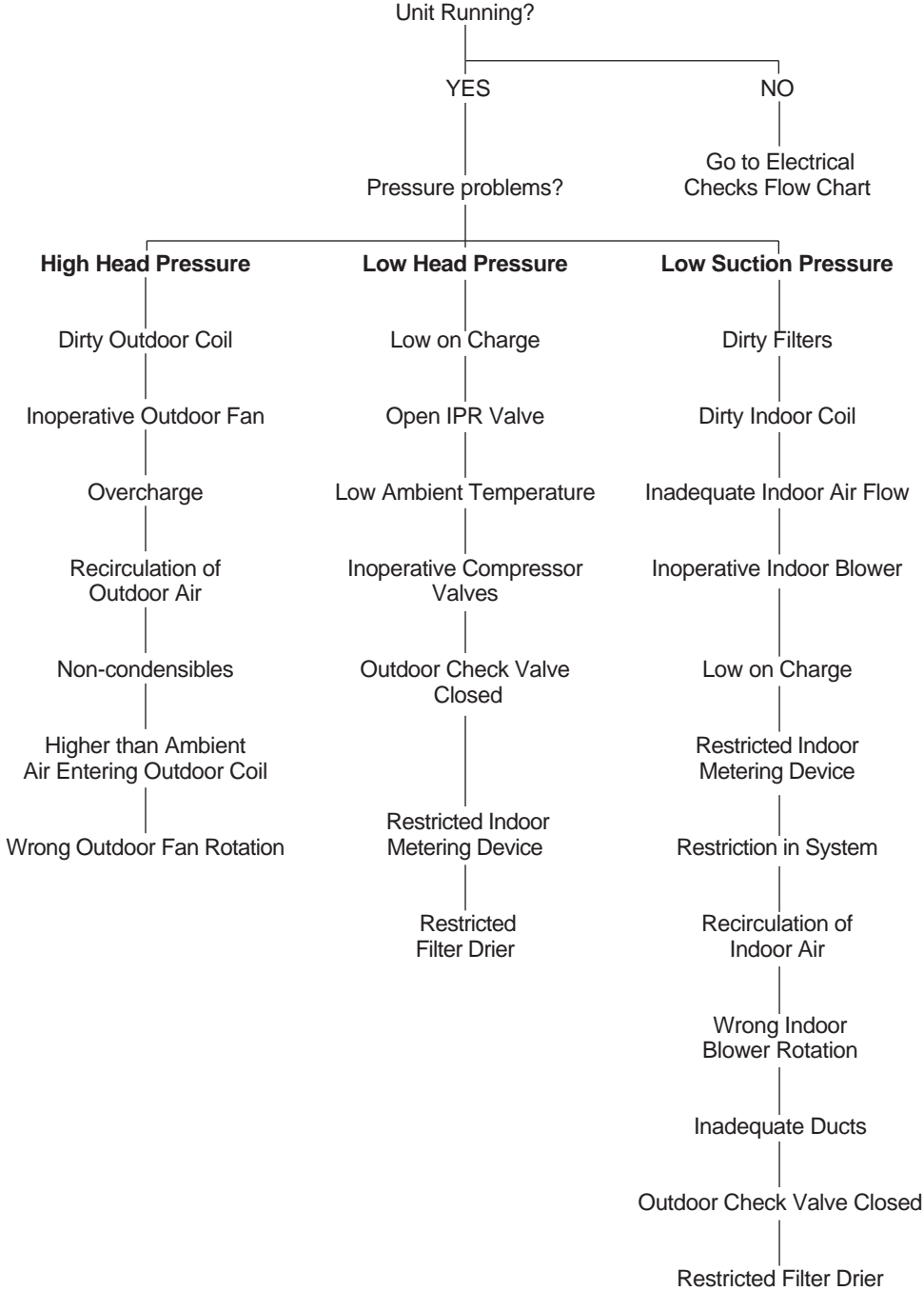

TABLE 9
TEMPERATURE PRESSURE CHART

TEMP (Deg. F)	R-410A PSIG
-150	—
-140	—
-130	—
-120	—
-110	—
-100	—
-90	—
-80	—
-70	—
-60	0.4
-50	5.1
-40	10.9
-35	14.2
-30	17.9
-25	22.0
-20	26.4
-15	31.3
-10	36.5
-5	42.2
0	48.4
5	55.1
10	62.4
15	70.2
20	78.5
25	87.5
30	97.2
35	107.5
40	118.5
45	130.2
50	142.7
55	156.0
60	170.1
65	185.1
70	201.0
75	217.8
80	235.6
85	254.5
90	274.3
95	295.3
100	317.4
105	340.6
110	365.1
115	390.9
120	418.0
125	446.5
130	476.5
135	508.0
140	541.2
145	576.0
150	612.8

SYSTEM CHARGE TROUBLESHOOTING

SUPERHEAT CALCULATION

1. Measure the suction pressure at the suction line service valve.
2. Convert the suction pressure to saturated temperature. See Table 9.
3. Measure the temperature of the suction line at the suction line service valve.
4. Compare the temperature to the suction line to the saturated temperature.
5. The difference between saturated temperature and suction line temperature is the superheat. Superheat normal range 9° to 16°.

SUBCOOLING CALCULATION

1. Measure the liquid pressure at the liquid line service valve.
2. Convert the liquid line pressure to saturated temperature. See Table 10.
3. Measure the liquid line temperature at the liquid line service valve.
4. Compare the liquid line temperature to the saturated temperature.
5. The difference between saturated temperature and liquid line temperature is the subcooling. Subcooling normal range 5° to 14°.

TABLE 10
AIR CONDITIONING SYSTEM TROUBLESHOOTING TIPS

AIR CONDITIONING SYSTEM TROUBLESHOOTING TIPS					
SYSTEM PROBLEM	INDICATORS				
	DISCHARGE PRESSURE	SUCTION PRESSURE	SUPERHEAT	SUBCOOLING	COMPRESSOR AMPS
Overcharge	High	High	Low	High	High
Undercharge	Low	Low	High	Low	Low
Liquid Restriction (Drier)	Low	Low	High	High	Low
Low Evaporator Airflow	Low	Low	Low	Low	Low
Dirty Condenser	High	High	Low	Low	High
Low Outside Ambient Temperature	Low	Low	High	High	Low
Inefficient Compressor	Low	High	High	High	Low
TXV Sensing Bulb Charge Lost	Low	Low	High	High	Low
Poorly Insulated Sensing Bulb	High	High	Low	Low	High

GENERAL TROUBLESHOOTING CHART

▲ WARNING

DISCONNECT ALL POWER TO UNIT BEFORE SERVICING. RELAY MAY BREAK ONLY ONE SIDE. FAILURE TO SHUT OFF POWER CAN CAUSE ELECTRICAL SHOCK RESULTING IN PERSONAL INJURY OR DEATH.

SYMPTOM	POSSIBLE CAUSE	REMEDY
Unit will not run	<ul style="list-style-type: none"> • Power off or loose electrical connection • Thermostat out of calibration-set too high • Blown fuses / tripped breaker • Transformer defective • Pressure control open 	<ul style="list-style-type: none"> • Check for correct voltage at control in condensing unit • Reset • Check for 24 volts at control • Replace fuses / reset breaker • Check wiring-replace transformer
Outdoor fan runs, compressor doesn't	<ul style="list-style-type: none"> • Run or start capacitor defective • Start relay defective • Loose connection • Compressor stuck, grounded or open motor winding, open internal overload. • Low voltage condition 	<ul style="list-style-type: none"> • Check for correct voltage at compressor - check & tighten all connections • Wait at least 2 hours for overload to reset.
Insufficient cooling	<ul style="list-style-type: none"> • Improperly sized unit • Improper indoor airflow • Incorrect refrigerant charge • Air, non-condensibles or moisture in system 	<ul style="list-style-type: none"> • Recalculate load • Check - should be approximately 400 CFM per ton. • Charge per procedure attached to unit service panel • Recover refrigerant, evacuate & recharge, add filter drier
Compressor short cycles	<ul style="list-style-type: none"> • Incorrect voltage • Defective overload protector • Refrigerant undercharge 	<ul style="list-style-type: none"> • Voltage must be $\pm 10\%$ of nameplate marking when unit is operating. • Add refrigerant
Registers sweat	<ul style="list-style-type: none"> • Low indoor airflow 	<ul style="list-style-type: none"> • Increase speed of blower or reduce restriction - replace air filter
High head-low vapor pressures	<ul style="list-style-type: none"> • Restriction in liquid line, expansion device or filter drier 	<ul style="list-style-type: none"> • Remove or replace defective component
High head-high or normal vapor pressure - Cooling mode	<ul style="list-style-type: none"> • Dirty outdoor coil • Refrigerant overcharge • Outdoor fan not running • Air or non-condensibles in system 	<ul style="list-style-type: none"> • Clean coil • Correct system charge • Repair or replace • Recover refrigerant, evacuate & recharge
Low vapor - cool compressor - iced indoor coil	<ul style="list-style-type: none"> • Low indoor airflow • Operating below 65°F outdoors • Moisture in system 	<ul style="list-style-type: none"> • Increase speed of blower or reduce restriction - replace air filter • Add Low Ambient Kit • Recover refrigerant - evacuate & recharge - add filter drier
High vapor pressure	<ul style="list-style-type: none"> • Excessive load • Defective compressor 	<ul style="list-style-type: none"> • Recheck load calculation
Fluctuating head & vapor pressures	<ul style="list-style-type: none"> • TXV hunting • Air or non-condensibles in system 	<ul style="list-style-type: none"> • Check TXV bulb clamp - check air distribution on coil - replace TXV • Recover refrigerant, evacuate & recharge
Gurgle or pulsing noise at expansion device or liquid line	<ul style="list-style-type: none"> • Air or non-condensibles in system 	<ul style="list-style-type: none"> • Recover refrigerant, evacuate & recharge

GENERAL SERVICE ANALYZER CHARTS

COMPRESSOR OVERHEATING		
SYMPTOMS	POSSIBLE CAUSE	CHECK/REMEDIES
High superheat	Low charge	Check system charge
	Faulty metering device	Restricted cap tube, TEV (TXV)
		Power element superheat adjustment
		Foreign matter stopping flow
	High internal load	Hot air (attic) entering return
		Heat source on; mis-wired or faulty control
	Restriction in liquid line	Drier plugged
		Line kinked
	Low head pressure	Low charge
		Operating in low ambient temperatures
Suction or liquid line subjected to high heat source	Hot attic	
	Hot water line	
Low voltage	Loose wire connections	Check wiring
	Power company problem, transformer	Have problem corrected before diagnosis continues
	Undersized wire feeding unit	Correct and complete diagnosis
High voltage	Power company problem	Have problem corrected
High head pressure	Overcharge	Check system charge
	Dirty heat pump coil	Clean coil
	Faulty or wrong size heat pump fan motor	Replace fan motor
	Faulty fan blade or wrong rotation	Replace fan blade
		Replace with correct rotation motor
	Recirculation of air	Correct installation
	Additional Heat Source	Check for dryer vent near unit
		Check for recirculation from other equipment
	Non-condensibles	Recover refrigerant, Evacuate and recharge system
Equipment not matched	Correct mis-match	
Short cycling of compressor	Faulty pressure control	Replace pressure control
	Loose wiring	Check unit wiring
	Thermostat	Located in supply air stream
		Differential setting too close
		Customer misuse
	TEV	Internal foreign matter
		Power element failure
		Valve too small
Distributor tube/tubes restricted		

CONTINUED
→

SYMPTOMS	POSSIBLE CAUSE	CHECK OR REMEDIES
Short cycling of compressor (cont.)	Low charge	Check system charge
	Low evaporator air flow	Dirty coil
		Dirty filter
		Duct too small or restricted
Faulty run capacitor	Replace	
Faulty internal overload	Replace compressor	
<i>ELECTRICAL (See Control Diagnostics)</i>		
SYMPTOMS	POSSIBLE CAUSE	CHECK OR REMEDIES
No voltage on line side of control board	Blown fuses or tripped circuit breaker	Check for short in wiring or unit
	Improper wiring	Re-check wiring diagram
Improper voltage	High voltage	Wrong unit
		Power supply problem
	Low voltage	Wrong unit
		Power supply problem
		Wiring undersized
Loose connections		
<i>CONTAMINATION</i>		
SYMPTOMS	POSSIBLE CAUSE	CHECK OR REMEDIES
Moisture	Poor evacuation on installation or during service	In each case, the cure is the same. Recover refrigerant. Add filter drier, evacuate and re-charge
High head pressure	Non-condensibles air	
Unusual head and suction readings	Wrong refrigerant	
Foreign Matter-copper filings	Copper tubing cuttings	
Copper oxide	Dirty copper piping	
Welding scale	Nitrogen not used	
Soldering flux	Adding flux before seating copper part way	
Excess soft solder	Wrong solder material	

CONTINUED
→

LOSS OF LUBRICATION		
SYMPTOMS	POSSIBLE CAUSE	CHECK OR REMEDIES
Compressor failures	Line tubing too long	Add oil to the recommended level
	Line tubing too large	Reduce pipe size to improve oil return
Low suction pressure	Low charge	Check system charge
	Refrigerant leaks	Repair and recharge
Cold, Noisy compressor - Slugging	Dilution of Oil with Refrigerant	Observe piping guidelines
Noisy compressor	Migration	Check crankcase heater
Cold, sweating compressor	Flooding	Check system charge
Low Load	Reduced air flow	Dirty filter
		Dirty coil
		Wrong duct size
		Restricted duct
Short cycling of compressor	Thermostat setting	Advise customer
	Faulty pressure control	Replace control
	Loose wiring	Check all control wires
	Thermostat	In supply air stream, out of calibration, Customer misuse
FLOODED STARTS		
SYMPTOMS	POSSIBLE CAUSES	CHECK OR REMEDIES
Liquid in the compressor shell	Faulty or missing crankcase heater	Replace crankcase heater
Too much liquid in system	Incorrect piping	Check Piping guidelines
	Overcharge	Check and adjust charge
SLUGGING		
SYMPTOMS	POSSIBLE CAUSES	CHECK OR REMEDIES
On start up	Incorrect piping	Review pipe size guidelines
TEV hunting when running	Oversized TEV	Check TEV application
FLOODING		
SYMPTOMS	POSSIBLE CAUSES	CHECK OR REMEDIES
Poor system control using a TEV	Loose sensing bulb	Secure the bulb and insulate
	Bulb in wrong location	Relocate bulb
	Wrong size TEV	Use correct replacement
	Improper superheat setting	Adjust, if possible; Replace, if not

CONTINUED
→

THERMOSTATIC EXPANSION VALVES

SYMPTOMS	POSSIBLE CAUSE	CHECK OR REMEDIES	
High Superheat, Low Suction Pressure	Moisture freezing and blocking valve	Recover charge, install filter-drier, evacuate system, recharge	
	Dirt or foreign material blocking valve	Recover charge, install filter-drier, evacuate system, recharge	
	Low refrigerant charge	Correct the charge	
	Vapor bubbles in liquid line	Remove restriction in liquid line	Remove restriction in liquid line
		Correct the refrigerant charge	Correct the refrigerant charge
		Remove non-condensable gases	Remove non-condensable gases
	Size liquid line correctly	Size liquid line correctly	
	Misapplication of internally equalized valve	Use correct TEV	
	Plugged external equalizer line	Remove external equalizer line restriction	
	Undersized TEV	Replace with correct valve	
	Loss of charge from power head sensing bulb	Replace power head or complete TEV	
Charge migration from sensing bulb to power head (Warm power head with warm, wet cloth. Does valve operate correctly now?)	Ensure TEV is warmer than sensing bulb		
Improper superheat adjustment (Only applicable to TEV with adjustable superheat settings)	Adjust superheat setting counter-clockwise		
Valve feeds too much refrigerant, with low superheat and higher than normal suction pressure	Moisture causing valve to stick open.	Recover refrigerant, replace filter-drier, evacuate system and then non-recharge	
	Dirt or foreign material causing valve to stick open	Recover refrigerant, replace filter-drier, evacuate system and recharge	
	TEV seat leak (A gurgling or hissing sound is heard AT THE TEV during the off cycle, if this is the cause.) NOT APPLICABLE TO BLEED PORT VALVES.	Replace the TEV	
	Oversized TEV	Install correct TEV	
	Incorrect sensing bulb location	Install bulb with two mounting straps, in 2:00 or 4:00 position on suction line, with insulation	
	Low superheat adjustment (only applicable to TEV with adjustable superheat setting)	Turn superheat adjustment clockwise	
	Incorrectly installed, or restricted external equalizer line	Remove restriction, or relocate external equalizer	
Compressor flood back upon start up	Refrigerant drainage from flooded evaporator	Install trap riser to the top of the evaporator coil	
	Compressor in cold location	Install crankcase heater on compressor	

CONTINUED
→

THERMOSTATIC EXPANSION VALVES

SYMPTOMS	POSSIBLE CAUSE	CHECK OR REMEDIES
Superheat is low to normal with low suction pressure	Unequal evaporator circuit loading	Ensure air flow is equally distributed through evaporator
		Check for blocked distributor tubes
	Low load or airflow entering evaporator coil	Ensure blower is moving proper air CFM
		Remove/Correct any air flow restriction
Superheat and suction pressure fluctuate (valve is hunting)	Expansion valve is oversized	Install correct TEV
	Sensing bulb is affected by liquid refrigerant or refrigerant oil flowing through suction line	Relocate sensing bulb in another position around the circumference of the suction line
	Unequal refrigerant flow through evaporator circuits	Ensure proper distributor piston is inserted in RCBA or RCHA coil
		Ensure sensing bulb is located properly
		Check for blocked distributor tubes
Improper superheat adjustment (only possible with TEV having superheat adjustment)	Replace TEV or adjust superheat	
Moisture freezing and partially blocking TEV	Recover refrigerant, change filter-drier, evacuate system and recharge	
Valve does not regulate at all	External equalizer line not connected or line plugged	Connect equalizer line in proper location, or remove any blockage
	Sensing bulb lost its operating charge	Replace TEV
	Valve body damaged during soldering or by improper installation	Replace TEV

CONTINUED

FIGURE 4
JEZ-DIAGNOSTIC LABEL

Caution – UNIT MAY START SUDDENLY AND WITHOUT WARNING
 Solid red LED light indicates a thermostat call for unit operation is present at the ICC.
 ICC will attempt to start unit after short cycle timer expires or when in Active Protection mode will attempt to restart unit prior to Lockout mode.

7 - Segment Display Code	Diagnostic Description	Status / Possible Cause - Troubleshooting Information
0	Standby	Standby - No call for operation
c	Y1	First Stage or Single Stage Unit Operation
C	Y2	Second Stage Unit Operation (2-stage unit only)
c or C Flashing	Anti-Short Cycle Timer (3 minutes) or Minimum Run Timer (30 seconds)	Waiting for anti-short cycle timer to expire Waiting for minimum run timer to expire
d	Defrost	Heat Pump Defrost Operation
d Flashing	Abnormal Defrost Condition (Defrost control exceeds maximum defrost time)	1. Defrost control miswired 2. Faulty defrost control
F	ICC Fuse Open	1. Low voltage wiring damage or miswired
1 (*)	Compressor Running Extremely Long Run Cycle (Cooling mode only)	1. Low refrigerant charge 2. Air ducts have substantial leakage 3. Check thermostat operation 4. Y2 thermostat signal may not be connected (2-stage units only) 5. Dirty outdoor coil
2 (*)	Pressure Control Trip (L terminal output only)	1. (See faults 21, L21, 23, L23)
21 (***)	Low Pressure Control Trip Note: Low-pressure control is ignored for 90 seconds after call for unit operation. Active Protection – The ICC will try to restart the unit after the pressure control automatically re-closes. Unit will try to restart 3 times in the same thermostat call for operation (Y1) before lockout (fault L21).	1. Unit is low on refrigerant charge 2. Indoor coil is frozen (cooling mode) 3. Dirty indoor coil or filter (cooling mode) 4. Indoor blower is not running (cooling mode) 5. Outdoor coil is frozen (heat pump mode) 6. Outdoor fan is not running (heat pump mode) 7. TEV is not operating correctly
L21 (**)	Lockout - Low Pressure Control Trip (**)	LPC tripped three consecutive times in same thermostat call
23 (***)	High Pressure Control Trip Active Protection – The ICC will try to restart the unit after the pressure control automatically re-closes. Unit will try to restart 3 times in the same thermostat call for operation (Y1) before lockout (fault L23)	1. Outdoor coil is dirty (cooling mode) 2. Outdoor fan is not running (cooling mode) 3. Dirty indoor coil or filter (heat pump mode) 4. Indoor blower is not running (heat pump mode) 5. Liquid line restriction (filter drier blocked, etc.) 6. Excessive refrigerant charge
L23 (**)	Lockout - High Pressure Control Trip (**)	HPC tripped three consecutive times in same thermostat call
25	Outdoor Ambient Temperature Sensor	1. ICC sensor damaged (ICC will continue to operate)
27	Abnormal Low Line or No Line Voltage (See unit nameplate for operating voltage)	1. Check incoming line voltage to the disconnect and unit 2. Check wiring connections
28	Abnormal High Line Voltage	1. Check line voltage
3 (*)	Short Cycling	1. Check thermostat for intermittent demand signal 2. Check thermostat location in zone (too close to discharge grill)
5 (*) (***)	Compressor will not run Active Protection – After detecting compressor will not run the ICC will shut the unit down. The control will try to restart the unit every 5 minutes for 4 tries. After that, the ICC will attempt a restart every 20 minutes up to 6 hours.	1. Check for damaged, miswired, or wrong run capacitor 2. Check for damaged or miswired start capacitor and relay 3. Check voltage levels at ICC and compressor 4. Check for broken wires, loose connectors, or miswired 5. Check compressor motor windings for continuity 6. Check for open compressor internal protector 7. Check for excessive liquid refrigerant in compressor
L5 (**)	Lockout – Check Compressor (**)	Lockout after 6 hours of attempted restart
-	ICC Mis-operation	1. Check ICC compressor relay
8 (*)	ICC Mis-operation (L terminal output only)	1. Check ICC compressor relay
9 (*)	ICC Secondary Voltage Low (< 18V)	1. Check transformer for miswiring or overloading.

ICC – Integrated Compressor Control

- (*) – Indicates the display code will be flashed as an output on the ICC “L” terminal. For example 2 flashes (blinks) from the “L” terminal output indicates a pressure control trip.
- (**) – Lockout modes are reset by removing line voltage, low voltage, or by pressing control **TEST** button for 1 second. The control will attempt to start the unit when the **TEST** button is pressed and released (See **TEST** button label)
- (***) – **Indicates Active Protection. Unit will attempt to restart automatically.**

Red LED Display Code	Diagnostic Description	Status Information
Solid On	Call for Unit Operation	Y1 call is present from the room thermostat at the control

For Additional Questions or Comments concerning the ICC call 1-888-923-2323

92-102221-01-02

FIGURE 5
JEZ TEST & FAULT RECALL LABEL

TEST MODE MANUAL OPERATION (TEST)

The **TEST** mode resets the ICC (Integrated Compressor Control) from any lockout mode or bypasses compressor anti-short cycle delay timer. To enter **TEST** mode press **TEST** button with insulated probe for 1 second and then release. A “t” will display on the 7-segment display. The “t” will remain unless an error is detected or a call for Y1 is present (red LED Y1 is on). A call for Y1 during **TEST** causes the control to exit **TEST** and enter a normal unit operation mode. During **TEST** mode the ICC will continue to activate the unit for up to 5 seconds (times out). To exit **TEST** mode at anytime press **TEST** button with insulated probe for 1 second and release. Note: If Y1 is present the ICC will exit from **TEST** mode the and unit will continue to run.

FAULT RECALL OPERATION (TEST and SW2)

To enter **FAULT RECALL** mode press both **TEST** and **SW2** buttons at the same time with insulated probes for 1 second and release. Upon entering and exiting the **FAULT RECALL** mode, the top and bottom segments of the 7-segment display will be activated. The ICC will automatically scroll through stored faults on the 7-segment display. Each fault is displayed one time with the top segment of the 7-segment display activated between faults. Each fault is displayed with the most recent fault displayed first. An “O” will be displayed when no faults are stored. The ICC will automatically exit the **FAULT RECALL** mode after displaying stored faults.

An example of one LPC fault and one HPC fault scrolled on the display is as shown below:



CLEAR FAULT HISTORY (TEST and SW2)

To clear **FAULT HISTORY** press both **TEST** and **SW2** buttons at the same time with insulated probes for 5 seconds and release. The top and bottom segments of the 7-segment display will be activated and flash to indicate the history has been cleared.

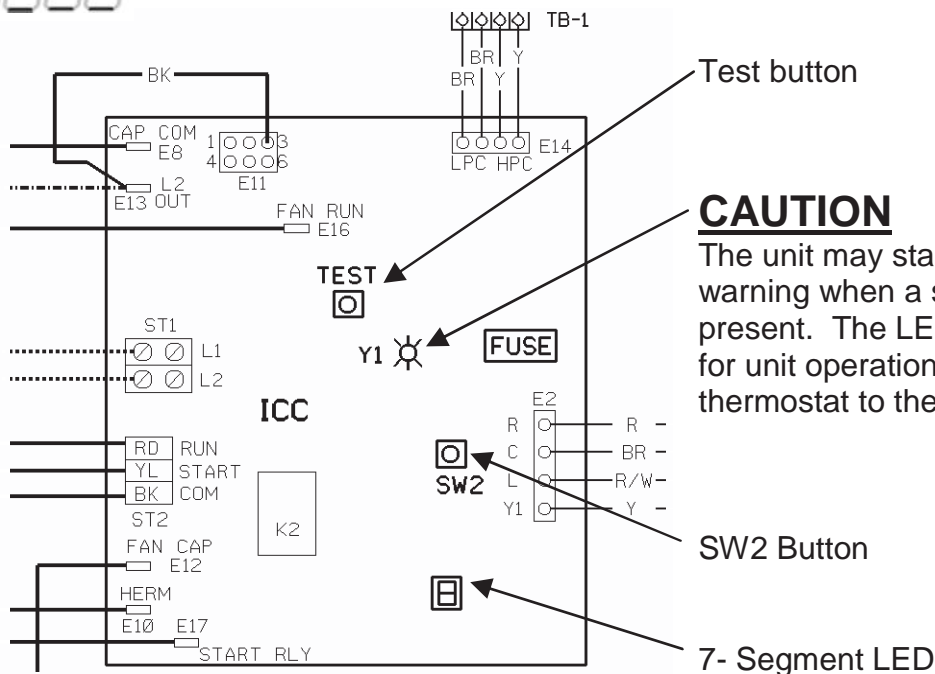
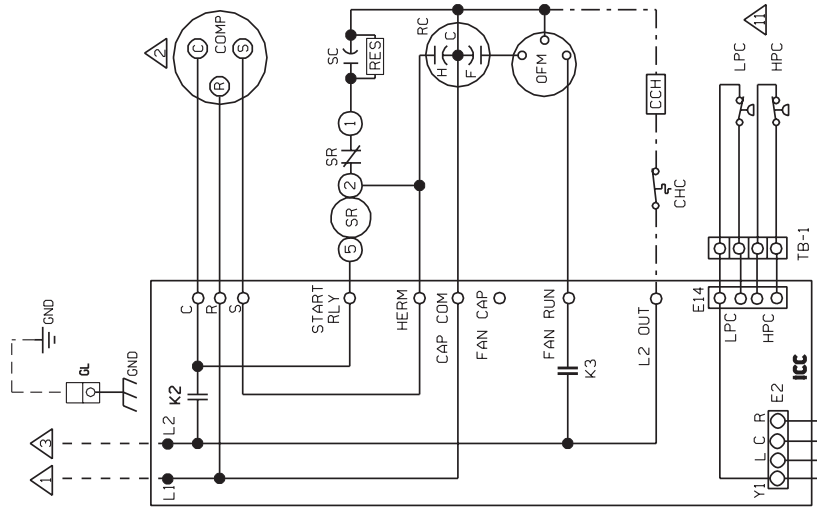
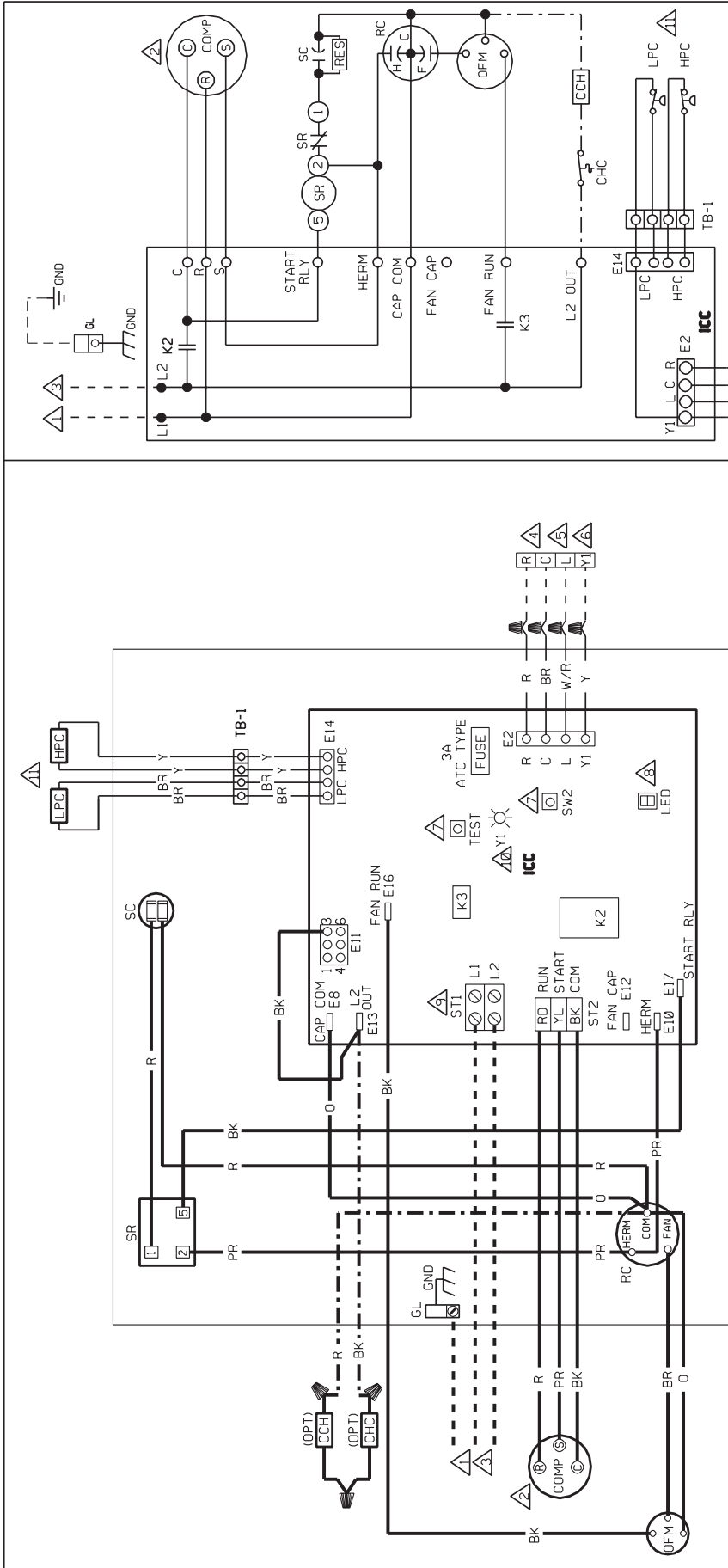

FIGURE 6
WIRING DIAGRAM



COMPONENT CODE

CCH	CRANK CASE HEATER CONTROL
COMP	COMPRESSOR
E	CONTROL BOARD WIRE TERMINATION
GL	GROUND LUG
GNL	GROUND, CHASSIS
HPC	HIGH PRES. CUT-OUT CONTROL
ICC	INTEGRATED COMPRESSOR CONTROL
K	CONTROL BOARD RELAY
LPC	LOW PRESSURE CONTROL
OPT	OPTIONAL FAN MOTOR
RC	RUN CAPACITOR
RES	RESISTOR
SC	START RELAY
SR	START RELAY
ST1	CONTROL BOARD POWER TERMINAL BLOCK
ST2	CONTROL BOARD COMPRESSOR WIRE TERMINAL BLOCK
TB	TERMINAL BLOCK

NOTES:

- CONNECTORS SUITABLE FOR USE WITH COPPER CONDUCTORS ONLY.
- COMPRESSOR MOTOR THERMALLY PROTECTED.
- CONNECT FIELD WIRING IN GROUNDED RAIN/TIGHT CONDUIT TO FUSED DISCONNECT, VOLTAGE, HERTZ, AND PHASE PER RATING PLATE, AND PER NATIONAL AND LOCAL CODES.
- LOW VOLTAGE CIRCUIT TO BE N.E.C.-CLASS 2, WITH A CLASS 2 TRANSFORMER 24 VOLT, 50 OR 60 HERTZ, MIN 18 ANG.
- TO THERMOSTAT, REFER TO SYSTEM SCHEMATICS OR SCHEMATICS ON INDOOR SECTION FOR LOW VOLTAGE CONTROL WIRING.
- L OUTPUT USED ON CERTAIN MODEL THERMOSTATS WITH L TERMINAL.
- TEST AND SW2 PUSH BUTTONS USED FOR TEST AND DIAGNOSTIC RECALL. SEE PUSH BUTTON LABEL FOR DETAILS.
- 7-SEGMENT LED TO DISPLAY DIAGNOSTIC CODES. SEE DIAGNOSTIC LABEL FOR DETAILS.
- TORQUE REQUIREMENTS 20 IN.-LB. CHECK ANNUALLY.
- SOLID ON INDICATES Y1 CALL PRESENT AT ICC CONTROL.
- LPC AND HPC ARE AUTOMATIC RESET SWITCHES.

WIRING INFORMATION

- LINE VOLTAGE
- FACTORY STANDARD
- FACTORY OPTION
- FIELD INSTALLED
- LOW VOLTAGE
- FACTORY STANDARD
- FACTORY OPTION
- FIELD INSTALLED
- REPLACE WIRE
- MUST BE THE SAME SIZE AND TYPE OF INSULATION AS ORIGINAL (105 C MIN.)
- WARNING
- CABINET MUST BE PERMANENTLY GROUNDED AND CONFORM TO I.E.C., N.E.C., C.E.C. AND LOCAL CODES AS APPLICABLE.

WIRE COLOR CODE

BK	BLACK	GY	GRAY	R	RED
BR	BROWN	O	ORANGE	W	WHITE
BL	BLUE	PK	PINK	Y	YELLOW
G	GREEN	PR	PURPLE		

ELECTRICAL WIRING DIAGRAM

AIR CONDITIONER
1 STAGE
INTEGRATED COMPRESSOR CONTROL

DR. BY	APP. BY	DATE	DWG. NO.	REV
MGR		6-21-05	910-102075-01	03

