



The new degree of comfort.™

Rheem *Commercial Classic*® Series Package Air Conditioner



RACA14- 14 SEER Series

Nominal Sizes 2-5 Tons [7.0-17.6 kW]

RACA15- 15 SEER Series

Nominal Sizes 2-5 Tons [7.0-17.6 kW]



(15 SEER/12.0 EER
AND ABOVE ONLY)

"Proper sizing and installation of equipment is critical to achieve optimal performance. Ask your Contractor for details or visit www.energystar.gov."



TABLE OF CONTENTS

Unit Features & Benefits	3-4
Model Number Identification	5
Available SKUs	5
General Data	
RACA14- Series	6-10
RACA15- Series	11-13
General Data Notes	14
Gross Systems Performance Data	
RACA14- Series	15-20
RACA15- Series	21-26
Indoor Airflow Performance	27-32
Electrical Data	
RACA14- Series	33-34
RACA15- Series	35-36
Electric Heater Kits	37-39
Dimensional Data	40-41
Typical Installations	42
Accessories	43-51
Limited Warranty	52

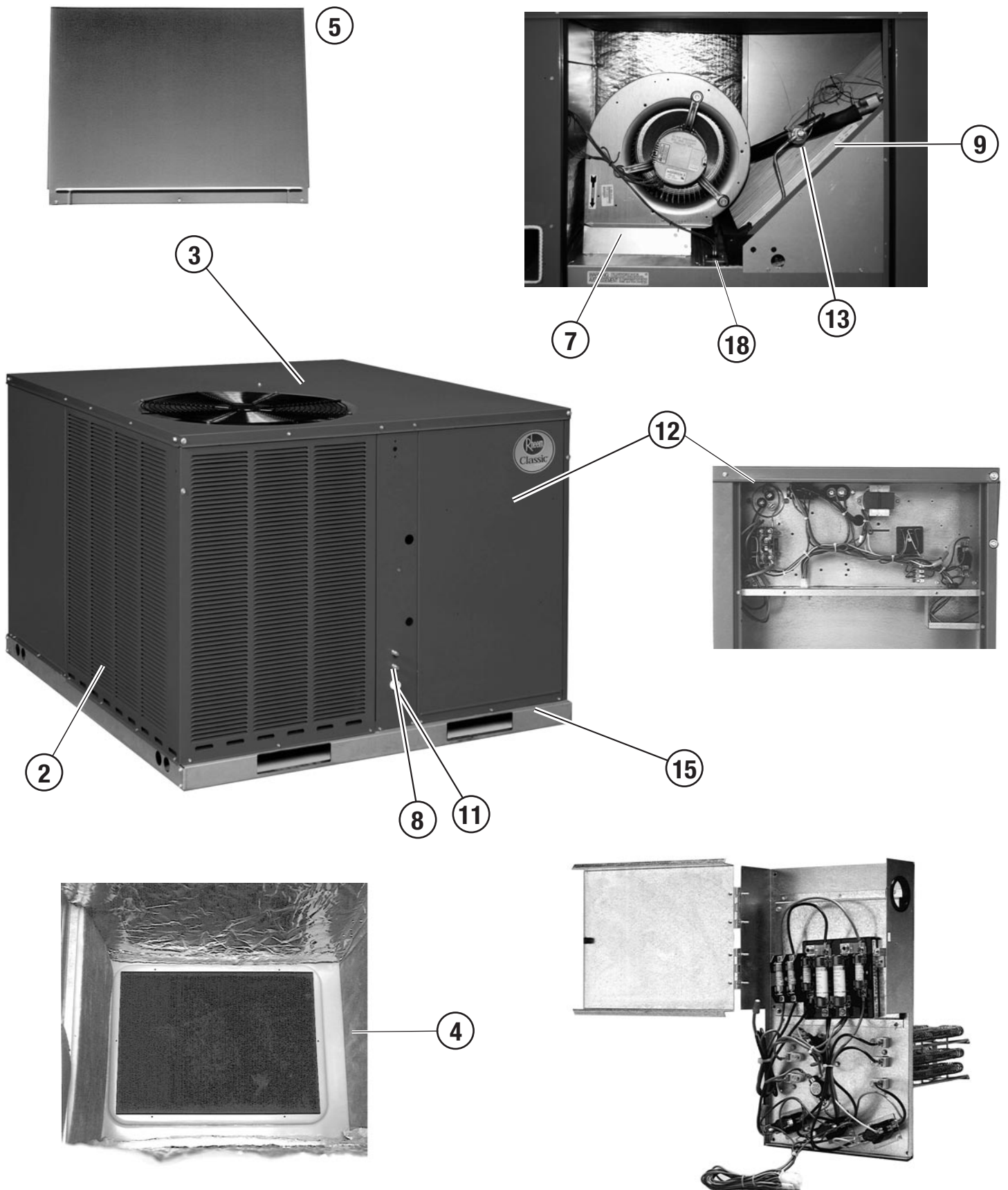



Features Below Correspond to Photos on Page 3

1. All models feature Scroll® compressors for maximum efficiency and quiet operation. The 5-Ton RACA15 model features Scroll UltraTech™ 2-Stage compressors with Comfort Alert™ diagnostics (see below), high/low pressure switches, and hard start kit.
2. Louvered condenser compartment to protect the coil against yard hazards and/or weather extremes.
3. One-piece top with a drip lip to help keep water off of the unit sides.
4. Drawn supply and return air openings feature a one-inch tall flange to prevent water migration into the ductwork.
5. Access panels have “weep holes” and channels to further help manage water run-off.
6. Side and down discharge options available on all models.
7. Easily accessible blower section complete with slide-out blower.
8. Externally mounted refrigerant connections are conveniently located for easy service diagnostics.
9. Micro Channel evaporator and condenser delivers superior performance with less refrigerant charge and less weight than conventional copper tube/aluminum fin coils. In addition the all aluminum construction has superior protection against formicary corrosion and aluminum tube rubbing potential. It is easier to clean and has a more robust surface.
10. Supplemental electric heat strips up to 15 kW are available (field or factory installed) for periods of extreme cold temperatures. Single point wiring simplifies installation.
11. All units feature an internal trap on the condensate line eliminating the need for installing an on-site external trap.
12. Easily accessible control box.
13. Thermal expansion valve standard on all models for superior superheat control, reliability, and energy efficiency at all operating conditions.
14. Solid core liquid line. Filter drier standard on all models (not shown).
15. Rugged baserail included for improved installation and handling.
16. Molded compressor plug.
17. Complete factory charged, wired and run tested.
18. A double sloped evaporator coil drain pan assures all water is removed from the unit to improve indoor air quality.

Comfort Alert™ Diagnostics – Faster Service And Improved Accuracy (5 Ton RACA15 2-Stage Model Only)

The Comfort Alert™ diagnostics module is a breakthrough innovation for troubleshooting air conditioning system failures. The module is installed in the control box near the compressor contactor. By monitoring and analyzing data from the Scroll® compressor and the thermostat demand, the module can accurately detect the cause of electrical and system related failures without any sensors. A flashing LED indicator communicates the ALERT code and guides the service technician more quickly and accurately to the root cause of a problem.

NOTE: Single phase module does not provide active compressor protection! The Comfort Alert module is a monitoring device and cannot control or shut down the compressor unless used with a compatible thermostat.

NOTE: Three phase module provides compressor protection and will shut down the compressor when compressor damaging conditions are detected.



R AC A 14 036 A J D 10 1 A A X X X

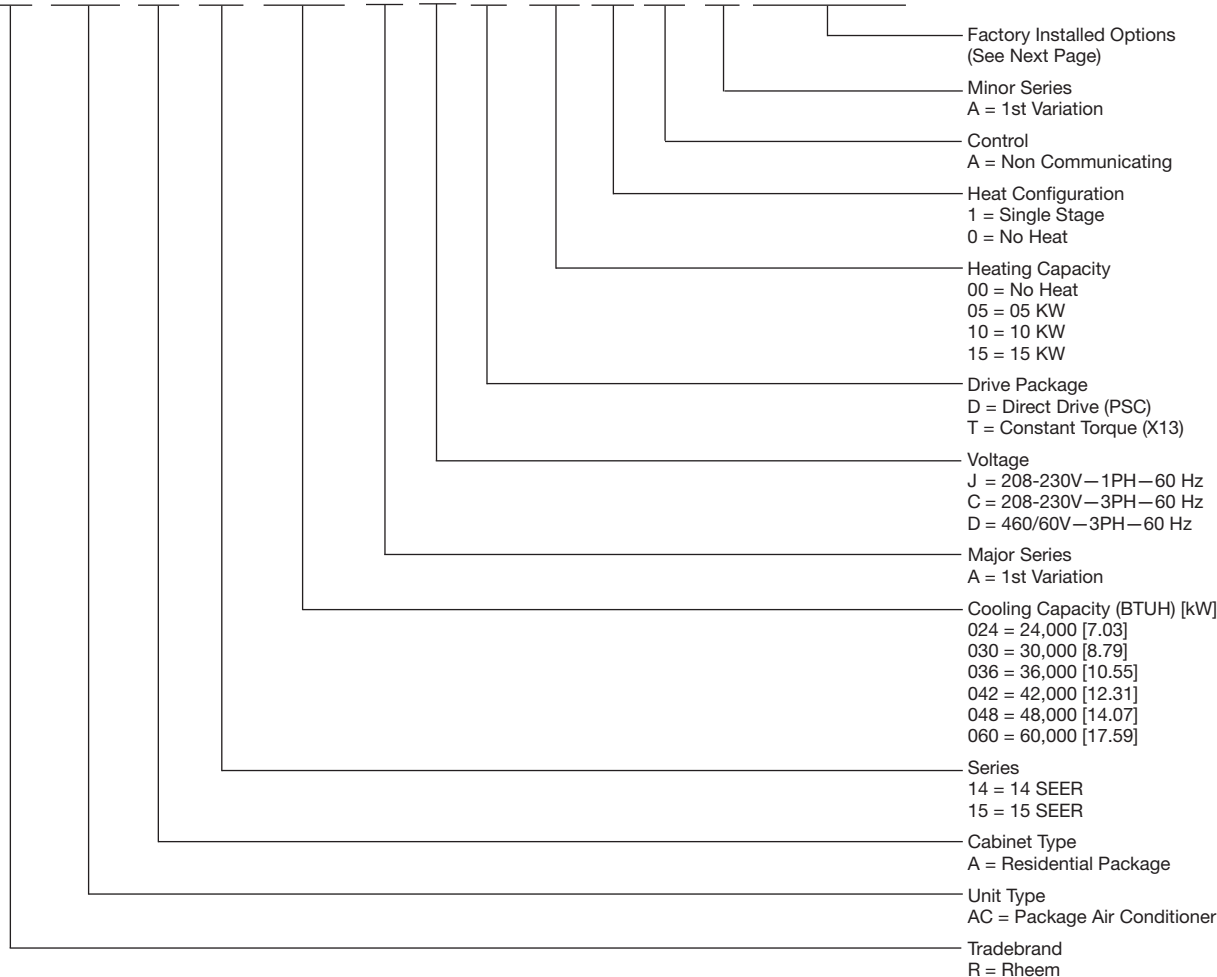

[] Designates Metric Conversions

Available SKUs

Available Models			
RACA14024BJT000AA	RACA14042AJT051AA	RACA15024AJT000AA	RACA15042AJT051AA
RACA14024BJT051AA	RACA14042AJT101AA	RACA15024AJT051AA	RACA15042AJT101AA
RACA14024BJT101AA	RACA14042AJT151AA	RACA15024AJT101AA	RACA15042AJT151AA
RACA14030BJT000AA	RACA14048BCT000AA	RACA15030AJT000AA	RACA15048ACT000AA
RACA14030BJT051AA	RACA14048BCT101AA	RACA15030AJT051AA	RACA15048ACT101AA
RACA14030BJT101AA	RACA14048BCT151AA	RACA15030AJT101AA	RACA15048ACT151AA
RACA14036BCT000AA	RACA14048BJT000AA	RACA15036ACT000AA	RACA15048AJT000AA
RACA14036BCT101AA	RACA14048BJT051AA	RACA15036ACT101AA	RACA15048AJT051AA
RACA14036BCT151AA	RACA14048BJT101AA	RACA15036ACT151AA	RACA15048AJT101AA
RACA14036BJT000AA	RACA14048BJT151AA	RACA15036AJT000AA	RACA15048AJT151AA
RACA14036BJT051AA	RACA14060ACT000AA	RACA15036AJT051AA	RACA15060ACT000AA
RACA14036BJT101AA	RACA14060ACT101AA	RACA15036AJT101AA	RACA15060ACT101AA
RACA14036BJT151AA	RACA14060ACT151AA	RACA15036AJT151AA	RACA15060ACT151AA
RACA14042ACT000AA	RACA14060AJT000AA	RACA15042ACT000AA	RACA15060AJT000AA
RACA14042ACT101AA	RACA14060AJT051AA	RACA15042ACT101AA	RACA15060AJT051AA
RACA14042ACT151AA	RACA14060AJT101AA	RACA15042ACT151AA	RACA15060AJT101AA
RACA14042AJT000AA	RACA14060AJT151AA	RACA15042AJT000AA	RACA15060AJT151AA



NOMINAL SIZES 2-5 TONS [7.0-17.6 kW]

Model RACA14 Series	024AJD***AA	024AJT***AA	024BJT***AA	030AJD***AA
Cooling Performance¹				CONTINUED →
Gross Cooling Capacity Btu [kW]	24,500 [7.18]	24,500 [7.18]	24,500 [7.18]	29,100 [8.53]
EER/SEER ²	11/14	11/14	11/14	11/14
Nominal CFM/AHRI Rated CFM [L/s]	800/900 [378/425]	800/900 [378/425]	800/900 [378/425]	1000/1000 [472/472]
AHRI Net Cooling Capacity Btu [kW]	23,600 [6.92]	23,600 [6.92]	23,600 [6.92]	28,000 [8.21]
Net Sensible Capacity Btu [kW]	17,700 [5.19]	17,700 [5.19]	17,700 [5.19]	21,000 [6.15]
Net Latent Capacity Btu [kW]	5,900 [1.73]	5,900 [1.73]	5,900 [1.73]	7,000 [2.06]
Net System Power kW	2.1	2.03	2.03	2.37
Compressor				
No./Type	1/Scroll	1/Scroll	1/Scroll	1/Scroll
Outdoor Sound Rating (dB)³				
	76	76	76	76
Outdoor Coil—Fin Type				
Tube Type	Louvered	Louvered	Louvered	Louvered
MicroChannel Depth in. [mm]	MicroChannel	MicroChannel	MicroChannel	MicroChannel
Face Area sq. ft. [sq. m]	0.71 [18]	0.71 [18]	0.71 [18]	0.71 [18]
Rows / FPI [FPcm]	7.1 [0.66]	7.1 [0.66]	7.1 [0.66]	9.9 [0.92]
	1 / 23 [9]	1 / 23 [9]	1 / 23 [9]	1 / 23 [9]
Indoor Coil—Fin Type				
Tube Type	Louvered	Louvered	Louvered	Louvered
MicroChannel Depth in. [mm]	MicroChannel	MicroChannel	MicroChannel	MicroChannel
Face Area sq. ft. [sq. m]	1 [25.4]	1 [25.4]	1 [25.4]	1 [25.4]
Rows / FPI [FPcm]	3.6 [0.33]	3.6 [0.33]	3.6 [0.33]	3.6 [0.33]
Refrigerant Control	1 / 17 [7]	1 / 17 [7]	1 / 17 [7]	1 / 23 [9]
Drain Connection No./Size in. [mm]	TX Valves	TX Valves	TX Valves	TX Valves
	1/0.75 [19.05]	1/0.75 [19.05]	1/0.75 [19.05]	1/0.75 [19.05]
Outdoor Fan—Type				
No. Used/Diameter in. [mm]	Propeller	Propeller	Propeller	Propeller
Drive Type/No. Speeds	1/22 [558.8]	1/22 [558.8]	1/22 [558.8]	1/22 [558.8]
CFM [L/s]	Direct/1	Direct/1	Direct/1	Direct/1
No. Motors/HP	2500 [1180]	2500 [1180]	2500 [1180]	2500 [1180]
Motor RPM	1 at 1/3 HP	1 at 1/3 HP	1 at 1/3 HP	1 at 1/3 HP
	1075	1075	1075	1075
Indoor Fan—Type				
No. Used/Diameter in. [mm]	FC Centrifugal	FC Centrifugal	FC Centrifugal	FC Centrifugal
Drive Type	1/9x7 [229x178]	1/10x9 [254x229]	1/10x9 [254x229]	1/10x9 [254x229]
No. Speeds	Direct	Direct	Direct	Direct
No. Motors	Multiple	Multiple	Multiple	Multiple
Motor HP	1	1	1	1
Motor RPM	1/4	1/3	1/3	1/2
Motor Frame Size	1075	1075	1075	1075
	48	48	48	48
Filter—Type				
Furnished	Field Supplied	Field Supplied	Field Supplied	Field Supplied
(NO.) Size Recommended in. [mm x mm x mm]	No	No	No	No
	(1)1x20x20 [25x508x508]	(1)1x20x20 [25x508x508]	(1)1x20x20 [25x508x508]	(1)1x24x24 [25x610x610]
Weights				
Net Weight lbs. [kg]	398 [181]	403 [183]	403 [183]	403 [183]
Ship Weight lbs. [kg]	408 [185]	413 [187]	413 [187]	413 [187]
Motor Frame Size	48	48	48	48
Filter—Type				
Furnished	Field Supplied	Field Supplied	Field Supplied	Field Supplied
(NO.) Size Recommended in. [mm x mm x mm]	No	No	No	No
	(1)1x20x20 [25x508x508]	(1)1x20x20 [25x508x508]	(1)1x20x20 [25x508x508]	(1)1x20x20 [25x508x508]
Refrigerant Charge Oz. [g]				
	42.6 [1208]	42.6 [1208]	42.6 [1208]	46.8 [1327]
Weights				
Net Weight lbs. [kg]	398 [181]	398 [181]	403 [183]	403 [183]
Ship Weight lbs. [kg]	408 [185]	408 [185]	413 [187]	413 [187]

See Page 14 for Notes.

[] Designates Metric Conversions

NOMINAL SIZES 2-5 TONS [7.0-17.6 kW]

Model RACA14 Series	030BJT***AA	036ACD***AA	036AJD***AA	036BCT***AA
Cooling Performance¹				CONTINUED →
Gross Cooling Capacity Btu [kW]	29,100 [8.53]	34,900 [10.23]	34,900 [10.23]	34,900 [10.23]
EER/SEER ²	11/14	11/14	11/14	11/14
Nominal CFM/AHRI Rated CFM [L/s]	1000/975 [472/460]	1200/1200 [566/566]	1200/1200 [566/566]	1200/1200 [566/566]
AHRI Net Cooling Capacity Btu [kW]	28,000 [8.21]	33,600 [9.85]	33,600 [9.85]	33,600 [9.85]
Net Sensible Capacity Btu [kW]	21,000 [6.15]	25,200 [7.39]	25,200 [7.39]	25,200 [7.39]
Net Latent Capacity Btu [kW]	7,000 [2.06]	8,400 [2.46]	8,400 [2.46]	8,400 [2.46]
Net System Power kW	2.21	2.93	2.89	2.77
Compressor				
No./Type	1/Scroll	1/Scroll	1/Scroll	1/Scroll
Outdoor Sound Rating (dB)³	76	76	76	76
Outdoor Coil—Fin Type	Louvered	Louvered	Louvered	Louvered
Tube Type	MicroChannel	MicroChannel	MicroChannel	MicroChannel
MicroChannel Depth in. [mm]	0.71 [18]	0.71 [18]	0.71 [18]	0.71 [18]
Face Area sq. ft. [sq. m]	9.9 [0.92]	9.8 [0.91]	9.8 [0.91]	9.8 [0.91]
Rows / FPI [FPcm]	1 / 23 [9]	1 / 23 [9]	1 / 23 [9]	1 / 23 [9]
Indoor Coil—Fin Type	Louvered	Louvered	Louvered	Louvered
Tube Type	MicroChannel	MicroChannel	MicroChannel	MicroChannel
MicroChannel Depth in. [mm]	1 [25.4]	1 [25.4]	1 [25.4]	1 [25.4]
Face Area sq. ft. [sq. m]	3.6 [0.33]	3.6 [0.33]	3.6 [0.33]	3.6 [0.33]
Rows / FPI [FPcm]	1 / 17 [7]	1 / 23 [9]	1 / 17 [7]	1 / 17 [7]
Refrigerant Control	TX Valves	TX Valves	TX Valves	TX Valves
Drain Connection No./Size in. [mm]	1/0.75 [19.05]	1/0.75 [19.05]	1/0.75 [19.05]	1/0.75 [19.05]
Outdoor Fan—Type	Propeller	Propeller	Propeller	Propeller
No. Used/Diameter in. [mm]	1/22 [558.8]	1/22 [558.8]	1/22 [558.8]	1/22 [558.8]
Drive Type/No. Speeds	Direct/1	Direct/1	Direct/1	Direct/1
CFM [L/s]	2500 [1180]	2700 [1274]	2700 [1274]	2700 [1274]
No. Motors/HP	1 at 1/3 HP	1 at 1/3 HP	1 at 1/3 HP	1 at 1/3 HP
Motor RPM	1075	1075	1075	1075
Indoor Fan—Type	FC Centrifugal	FC Centrifugal	FC Centrifugal	FC Centrifugal
No. Used/Diameter in. [mm]	1/10x9 [254x229]	1/12x9 [305x229]	1/12x9 [305x229]	1/12x9 [305x229]
Drive Type	Direct	Direct	Direct	Direct
No. Speeds	Multiple	Multiple	Multiple	Multiple
No. Motors	1	1	1	1
Motor HP	1/2	1/2	1/2	1/2
Motor RPM	1075	1075	1075	1075
Motor Frame Size	48	48	48	48
Filter—Type	Field Supplied	Field Supplied	Field Supplied	Field Supplied
Furnished	No	No	No	No
(NO.) Size Recommended in. [mm x mm x mm]	(1)1x24x24 [25x610x610]	(1)1x24x24 [25x610x610]	(1)1x24x24 [25x610x610]	(1)1x24x24 [25x610x610]
Weights				
Net Weight lbs. [kg]	403 [183]	411 [186]	411 [186]	411 [186]
Ship Weight lbs. [kg]	413 [187]	421 [191]	421 [191]	421 [191]
Motor Frame Size	48	48	48	48
Filter—Type	Field Supplied	Field Supplied	Field Supplied	Field Supplied
Furnished	No	No	No	No
(NO.) Size Recommended in. [mm x mm x mm]	(1)1x20x20 [25x508x508]	(1)1x20x20 [25x508x508]	(1)1x20x20 [25x508x508]	(1)1x20x20 [25x508x508]
Refrigerant Charge Oz. [g]	46.8 [1327]	52.7 [1494]	52.7 [1494]	52.7 [1494]
Weights				
Net Weight lbs. [kg]	398 [181]	398 [181]	403 [183]	403 [183]
Ship Weight lbs. [kg]	408 [185]	408 [185]	413 [187]	413 [187]

See Page 14 for Notes.

[] Designates Metric Conversions

NOMINAL SIZES 2-5 TONS [7.0-17.6 kW]

Model RACA14 Series	036BJT***AA	042ACT***AA	042AJT***AA	048ACT***AA
Cooling Performance¹				CONTINUED →
Gross Cooling Capacity Btu [kW]	34,900 [10.23]	40,100 [11.75]	40,100 [11.75]	46,000 [13.48]
EER/SEER ²	11/14	11/14	11/14	11/14
Nominal CFM/AHRI Rated CFM [L/s]	1200/1200 [566/566]	1400/1300 [661/613]	1400/1300 [661/613]	1600/1550 [755/731]
AHRI Net Cooling Capacity Btu [kW]	33,600 [9.85]	39,000 [11.43]	39,000 [11.43]	44,500 [13.04]
Net Sensible Capacity Btu [kW]	25,200 [7.39]	29,250 [8.57]	29,250 [8.57]	31,150 [9.13]
Net Latent Capacity Btu [kW]	8,400 [2.46]	9,750 [2.86]	9,750 [2.86]	13,350 [3.91]
Net System Power kW	2.77	3.27	3.27	4
Compressor				
No./Type	1/Scroll	1/Scroll	1/Scroll	1/Scroll
Outdoor Sound Rating (dB)³	76	76	76	78
Outdoor Coil—Fin Type	Louvered	Louvered	Louvered	Louvered
Tube Type	MicroChannel	MicroChannel	MicroChannel	MicroChannel
MicroChannel Depth in. [mm]	0.71 [18]	0.71 [18]	0.71 [18]	0.71 [18]
Face Area sq. ft. [sq. m]	9.8 [0.91]	14.1 [1.31]	14.1 [1.31]	16.3 [1.51]
Rows / FPI [FPcm]	1 / 23 [9]	1 / 23 [9]	1 / 23 [9]	1 / 23 [9]
Indoor Coil—Fin Type	Louvered	Louvered	Louvered	Louvered
Tube Type	MicroChannel	MicroChannel	MicroChannel	MicroChannel
MicroChannel Depth in. [mm]	1 [25.4]	1 [25.4]	1 [25.4]	1 [25.4]
Face Area sq. ft. [sq. m]	3.6 [0.33]	3.6 [0.33]	3.6 [0.33]	4.1 [0.38]
Rows / FPI [FPcm]	1 / 17 [7]	1 / 17 [7]	1 / 17 [7]	1 / 20 [8]
Refrigerant Control	TX Valves	TX Valves	TX Valves	TX Valves
Drain Connection No./Size in. [mm]	1/0.75 [19.05]	1/0.75 [19.05]	1/0.75 [19.05]	1/0.75 [19.05]
Outdoor Fan—Type	Propeller	Propeller	Propeller	Propeller
No. Used/Diameter in. [mm]	1/22 [558.8]	1/22 [558.8]	1/22 [558.8]	1/22 [558.8]
Drive Type/No. Speeds	Direct/1	Direct/1	Direct/1	Direct/1
CFM [L/s]	2700 [1274]	3500 [1652]	3500 [1652]	3300 [1557]
No. Motors/HP	1 at 1/3 HP	1 at 1/3 HP	1 at 1/3 HP	1 at 1/3 HP
Motor RPM	1075	1075	1075	1075
Indoor Fan—Type	FC Centrifugal	FC Centrifugal	FC Centrifugal	FC Centrifugal
No. Used/Diameter in. [mm]	1/12x9 [305x229]	1/12x9 [305x229]	1/12x9 [305x229]	1/12x9 [305x229]
Drive Type	Direct	Direct	Direct	Direct
No. Speeds	Multiple	Multiple	Multiple	Multiple
No. Motors	1	1	1	1
Motor HP	1/2	3/4	3/4	3/4
Motor RPM	1075	1075	1075	1075
Motor Frame Size	48	48	48	48
Filter—Type	Field Supplied	Field Supplied	Field Supplied	Field Supplied
Furnished	No	No	No	No
(NO.) Size Recommended in. [mm x mm x mm]	(1)1x24x24 [25x610x610]	(1)1x24x24 [25x610x610]	(1)1x24x24 [25x610x610]	(1)1x24x24 [25x610x610]
Weights				
Net Weight lbs. [kg]	411 [186]	441 [200]	441 [200]	477 [216]
Ship Weight lbs. [kg]	421 [191]	451 [205]	451 [205]	487 [221]
Motor Frame Size	48	48	48	48
Filter—Type	Field Supplied	Field Supplied	Field Supplied	Field Supplied
Furnished	No	No	No	No
(NO.) Size Recommended in. [mm x mm x mm]	(1)1x20x20 [25x508x508]	(1)1x20x20 [25x508x508]	(1)1x20x20 [25x508x508]	(1)1x20x20 [25x508x508]
Refrigerant Charge Oz. [g]	52.7 [1494]	53.6 [1520]	53.6 [1520]	69.3 [1965]
Weights				
Net Weight lbs. [kg]	398 [181]	398 [181]	403 [183]	403 [183]
Ship Weight lbs. [kg]	408 [185]	408 [185]	413 [187]	413 [187]

See Page 14 for Notes.

[] Designates Metric Conversions

NOMINAL SIZES 2-5 TONS [7.0-17.6 kW]

Model RACA14 Series	048AJT***AA	048BCT***AA	048BJT***AA	060ACT***AA
Cooling Performance¹				CONTINUED →
Gross Cooling Capacity Btu [kW]	46,000 [13.48]	46,000 [13.48]	46,000 [13.48]	56,400 [16.53]
EER/SEER ²	11/14	11/14	11/14	11/14
Nominal CFM/AHRI Rated CFM [L/s]	1600/1550 [755/731]	1600/1550 [755/731]	1600/1550 [755/731]	2000/1700 [944/802]
AHRI Net Cooling Capacity Btu [kW]	44,500 [13.04]	44,500 [13.04]	44,500 [13.04]	54,500 [15.97]
Net Sensible Capacity Btu [kW]	31,150 [9.13]	31,150 [9.13]	31,150 [9.13]	38,150 [11.18]
Net Latent Capacity Btu [kW]	13,350 [3.91]	13,350 [3.91]	13,350 [3.91]	16,350 [4.79]
Net System Power kW	4	3.66	3.66	4.94
Compressor				
No./Type	1/Scroll	1/Scroll	1/Scroll	1/Scroll
Outdoor Sound Rating (dB)³	78	78	78	79
Outdoor Coil—Fin Type	Louvered	Louvered	Louvered	Louvered
Tube Type	MicroChannel	MicroChannel	MicroChannel	MicroChannel
MicroChannel Depth in. [mm]	0.71 [18]	0.71 [18]	0.7 [17.8]	1 [25.4]
Face Area sq. ft. [sq. m]	16.3 [1.51]	16.3 [1.51]	16.3 [1.51]	15.3 [1.42]
Rows / FPI [FPcm]	1 / 23 [9]	1 / 23 [9]	1 / 23 [9]	1 / 23 [9]
Indoor Coil—Fin Type	Louvered	Louvered	Louvered	Louvered
Tube Type	MicroChannel	MicroChannel	MicroChannel	MicroChannel
MicroChannel Depth in. [mm]	1 [25.4]	1.26 [32]	1.26 [32]	1.26 [32]
Face Area sq. ft. [sq. m]	4.1 [0.38]	4.1 [0.38]	4.1 [0.38]	4 [0.37]
Rows / FPI [FPcm]	1 / 20 [8]	1 / 20 [8]	1 / 20 [8]	1 / 20 [8]
Refrigerant Control	TX Valves	TX Valves	TX Valves	TX Valves
Drain Connection No./Size in. [mm]	1/0.75 [19.05]	1/0.75 [19.05]	1/0.75 [19.05]	1/0.75 [19.05]
Outdoor Fan—Type	Propeller	Propeller	Propeller	Propeller
No. Used/Diameter in. [mm]	1/22 [558.8]	1/22 [558.8]	1/22 [558.8]	1/22 [558.8]
Drive Type/No. Speeds	Direct/1	Direct/1	Direct/1	Direct/1
CFM [L/s]	3300 [1557]	3300 [1557]	3300 [1557]	3400 [1604]
No. Motors/HP	1 at 1/3 HP	1 at 1/3 HP	1 at 1/3 HP	1 at 1/3 HP
Motor RPM	1075	1075	1075	1075
Indoor Fan—Type	FC Centrifugal	FC Centrifugal	FC Centrifugal	FC Centrifugal
No. Used/Diameter in. [mm]	1/12x9 [305x229]	1/12x9 [305x229]	1/12x9 [305x229]	1/12x9 [305x229]
Drive Type	Direct	Direct	Direct	Direct
No. Speeds	Multiple	Multiple	Multiple	Multiple
No. Motors	1	1	1	1
Motor HP	3/4	3/4	3/4	1
Motor RPM	1075	1075	1075	1075
Motor Frame Size	48	48	48	48
Filter—Type	Field Supplied	Field Supplied	Field Supplied	Field Supplied
Furnished	No	No	No	No
(NO.) Size Recommended in. [mm x mm x mm]	(1)1x24x24 [25x610x610]	(1)1x24x24 [25x610x610]	(1)1x24x24 [25x610x610]	(1)1x24x30 [25x610x762]
Weights				
Net Weight lbs. [kg]	477 [216]	492 [223]	492 [223]	512 [232]
Ship Weight lbs. [kg]	487 [221]	502 [228]	502 [228]	522 [237]
Motor Frame Size	48	48	48	48
Filter—Type	Field Supplied	Field Supplied	Field Supplied	Field Supplied
Furnished	No	No	No	No
(NO.) Size Recommended in. [mm x mm x mm]	(1)1x20x20 [25x508x508]	(1)1x20x20 [25x508x508]	(1)1x20x20 [25x508x508]	(1)1x20x20 [25x508x508]
Refrigerant Charge Oz. [g]	69.3 [1965]	85.3 [2418]	85.3 [2418]	83.1 [2356]
Weights				
Net Weight lbs. [kg]	398 [181]	398 [181]	403 [183]	403 [183]
Ship Weight lbs. [kg]	408 [185]	408 [185]	413 [187]	413 [187]

See Page 14 for Notes.

[] Designates Metric Conversions



NOMINAL SIZES 2-5 TONS [7.0-17.6 kW]

Model RACA14 Series	060AJT***AA
Cooling Performance¹	
Gross Cooling Capacity Btu [kW]	56,400 [16.53]
EER/SEER ²	11/14
Nominal CFM/AHRI Rated CFM [L/s]	2000/1700 [944/802]
AHRI Net Cooling Capacity Btu [kW]	54,500 [15.97]
Net Sensible Capacity Btu [kW]	38,150 [11.18]
Net Latent Capacity Btu [kW]	16,350 [4.79]
Net System Power kW	4.94
Compressor	
No./Type	1/Scroll
Outdoor Sound Rating (dB)³	
	79
Outdoor Coil—Fin Type	
Tube Type	Louvered
MicroChannel Depth in. [mm]	MicroChannel
Face Area sq. ft. [sq. m]	1 [25.4]
Rows / FPI [FPcm]	15.3 [1.42]
	1 / 23 [9]
Indoor Coil—Fin Type	
Tube Type	Louvered
MicroChannel Depth in. [mm]	MicroChannel
Face Area sq. ft. [sq. m]	1.26 [32]
Rows / FPI [FPcm]	4 [0.37]
Refrigerant Control	1 / 20 [8]
Drain Connection No./Size in. [mm]	TX Valves
	1/0.75 [19.05]
Outdoor Fan—Type	
No. Used/Diameter in. [mm]	Propeller
Drive Type/No. Speeds	1/22 [558.8]
CFM [L/s]	Direct/1
No. Motors/HP	3400 [1604]
Motor RPM	1 at 1/3 HP
	1075
Indoor Fan—Type	
No. Used/Diameter in. [mm]	FC Centrifugal
Drive Type	1/12x9 [305x229]
No. Speeds	Direct
No. Motors	Multiple
Motor HP	1
Motor RPM	1
Motor Frame Size	1075
	48
Filter—Type	
Furnished	Field Supplied
(NO.) Size Recommended in. [mm x mm x mm]	No
	(1)1x24x30 [25x610x762]
Weights	
Net Weight lbs. [kg]	512 [232]
Ship Weight lbs. [kg]	522 [237]
Motor Frame Size	48
Filter—Type	
Furnished	Field Supplied
(NO.) Size Recommended in. [mm x mm x mm]	No
	(1)1x20x20 [25x508x508]
Refrigerant Charge Oz. [g]	
	83.1 [2356]
Weights	
Net Weight lbs. [kg]	398 [181]
Ship Weight lbs. [kg]	408 [185]

See Page 14 for Notes.

[] Designates Metric Conversions



NOMINAL SIZES 2-5 TONS [7.0-17.6 kW]

Model RACA15 Series	024AJT***AA	030AJT***AA	036ACT***AA	036AJT***AA
Cooling Performance¹				CONTINUED →
Gross Cooling Capacity Btu [kW]	24,600 [7.21]	29,600 [8.67]	36,000 [10.55]	36,000 [10.55]
EER/SEER ²	12/15	12/15	12/15	12/15
Nominal CFM/AHRI Rated CFM [L/s]	800/900 [378/425]	1000/975 [472/460]	1200/1200 [566/566]	1200/1200 [566/566]
AHRI Net Cooling Capacity Btu [kW]	24,000 [7.03]	29,000 [8.5]	35,000 [10.25]	35,000 [10.25]
Net Sensible Capacity Btu [kW]	18,100 [5.3]	21,500 [6.3]	25,400 [7.44]	25,400 [7.44]
Net Latent Capacity Btu [kW]	5,900 [1.73]	7,500 [2.2]	9,600 [2.81]	9,600 [2.81]
Net System Power kW	2.03	2.21	2.77	2.77
Compressor				
No./Type	1/Scroll	1/Scroll	1/Scroll	1/Scroll
Outdoor Sound Rating (dB)³	76	76	76	76
Outdoor Coil—Fin Type	Louvered	Louvered	Louvered	Louvered
Tube Type	MicroChannel	MicroChannel	MicroChannel	MicroChannel
MicroChannel Depth in. [mm]	0.71 [18]	0.71 [18]	0.71 [18]	0.71 [18]
Face Area sq. ft. [sq. m]	7.1 [0.66]	7.1 [0.66]	7.1 [0.66]	7.1 [0.66]
Rows / FPI [FPcm]	1 / 23 [9]	1 / 23 [9]	1 / 23 [9]	1 / 23 [9]
Indoor Coil—Fin Type	Louvered	Louvered	Louvered	Louvered
Tube Type	MicroChannel	MicroChannel	MicroChannel	MicroChannel
MicroChannel Depth in. [mm]	1 [25.4]	1 [25.4]	1 [25.4]	1 [25.4]
Face Area sq. ft. [sq. m]	3.6 [0.33]	3.6 [0.33]	3.6 [0.33]	3.6 [0.33]
Rows / FPI [FPcm]	1 / 17 [7]	1 / 17 [7]	1 / 17 [7]	1 / 17 [7]
Refrigerant Control	TX Valves	TX Valves	TX Valves	TX Valves
Drain Connection No./Size in. [mm]	1/0.75 [19.05]	1/0.75 [19.05]	1/0.75 [19.05]	1/0.75 [19.05]
Outdoor Fan—Type	Propeller	Propeller	Propeller	Propeller
No. Used/Diameter in. [mm]	1/22 [558.8]	1/22 [558.8]	1/22 [558.8]	1/22 [558.8]
Drive Type/No. Speeds	Direct/1	Direct/1	Direct/1	Direct/1
CFM [L/s]	2500 [1180]	2500 [1180]	2700 [1274]	2700 [1274]
No. Motors/HP	1 at 1/3 HP	1 at 1/3 HP	1 at 1/3 HP	1 at 1/3 HP
Motor RPM	1075	1075	1075	1075
Indoor Fan—Type	FC Centrifugal	FC Centrifugal	FC Centrifugal	FC Centrifugal
No. Used/Diameter in. [mm]	1/10x9 [254x229]	1/10x9 [254x229]	1/10x9 [254x229]	1/10x9 [254x229]
Drive Type	Direct	Direct	Direct	Direct
No. Speeds	Multiple	Multiple	Multiple	Multiple
No. Motors	1	1	1	1
Motor HP	1/3	1/2	1/2	1/2
Motor RPM	1075	1075	1075	1075
Motor Frame Size	48	48	48	48
Filter—Type	Field Supplied	Field Supplied	Field Supplied	Field Supplied
Furnished	No	No	No	No
(NO.) Size Recommended in. [mm x mm x mm]	(1)1x20x20 [25x508x508]	(1)1x24x24 [25x610x610]	(1)1x24x24 [25x610x610]	(1)1x24x24 [25x610x610]
Refrigerant Charge Oz. [g]	42.6 [1208]	46.8 [1327]	52.7 [1494]	52.7 [1494]
Weights				
Net Weight lbs. [kg]	403 [183]	403 [183]	411 [186]	411 [186]
Ship Weight lbs. [kg]	413 [187]	413 [187]	421 [191]	421 [191]

See Page 14 for Notes.

[] Designates Metric Conversions



NOMINAL SIZES 2-5 TONS [7.0-17.6 kW]

Model RACA15 Series	042ACT***AA	042AJT***AA	048ACT***AA	048AJT***AA
Cooling Performance¹				CONTINUED →
Gross Cooling Capacity Btu [kW]	41,000 [12.01]	41,000 [12.01]	47,500 [13.92]	47,500 [13.92]
EER/SEER ²	12/15	12/15	12/15	12/15
Nominal CFM/AHRI Rated CFM [L/s]	1400/1300 [661/613]	1400/1300 [661/613]	1600/1550 [755/731]	1600/1550 [755/731]
AHRI Net Cooling Capacity Btu [kW]	40,000 [11.72]	40,000 [11.72]	46,000 [13.48]	46,000 [13.48]
Net Sensible Capacity Btu [kW]	28,600 [8.38]	28,600 [8.38]	33,000 [9.67]	33,000 [9.67]
Net Latent Capacity Btu [kW]	11,400 [3.34]	11,400 [3.34]	13,000 [3.81]	13,000 [3.81]
Net System Power kW	3.28	3.28	3.66	3.66
Compressor				
No./Type	1/Scroll	1/Scroll	1/Scroll	1/Scroll
Outdoor Sound Rating (dB)³				
	76	76	76	76
Outdoor Coil—Fin Type				
Tube Type	Louvered	Louvered	Louvered	Louvered
MicroChannel Depth in. [mm]	MicroChannel	MicroChannel	MicroChannel	MicroChannel
Face Area sq. ft. [sq. m]	0.71 [18]	0.71 [18]	0.71 [18]	0.71 [18]
Rows / FPI [FPcm]	14.1 [1.31]	14.1 [1.31]	14.1 [1.31]	14.1 [1.31]
	1 / 23 [9]	1 / 23 [9]	1 / 23 [9]	1 / 23 [9]
Indoor Coil—Fin Type				
Tube Type	Louvered	Louvered	Louvered	Louvered
MicroChannel Depth in. [mm]	MicroChannel	MicroChannel	MicroChannel	MicroChannel
Face Area sq. ft. [sq. m]	1 [25.4]	1 [25.4]	1 [25.4]	1 [25.4]
Rows / FPI [FPcm]	3.6 [0.33]	3.6 [0.33]	3.6 [0.33]	3.6 [0.33]
	1 / 17 [7]	1 / 17 [7]	1 / 17 [7]	1 / 17 [7]
Refrigerant Control	TX Valves	TX Valves	TX Valves	TX Valves
Drain Connection No./Size in. [mm]	1/0.75 [19.05]	1/0.75 [19.05]	1/0.75 [19.05]	1/0.75 [19.05]
Outdoor Fan—Type				
No. Used/Diameter in. [mm]	Propeller	Propeller	Propeller	Propeller
Drive Type/No. Speeds	1/22 [558.8]	1/22 [558.8]	1/22 [558.8]	1/22 [558.8]
CFM [L/s]	Direct/1	Direct/1	Direct/1	Direct/1
No. Motors/HP	3500 [1652]	3500 [1652]	3300 [1557]	3300 [1557]
Motor RPM	1 at 1/3 HP	1 at 1/3 HP	1 at 1/3 HP	1 at 1/3 HP
	1075	1075	1075	1075
Indoor Fan—Type				
No. Used/Diameter in. [mm]	FC Centrifugal	FC Centrifugal	FC Centrifugal	FC Centrifugal
Drive Type	1/12x9 [305x229]	1/12x9 [305x229]	1/12x9 [305x229]	1/12x9 [305x229]
No. Speeds	Direct	Direct	Direct	Direct
No. Motors	Multiple	Multiple	Multiple	Multiple
Motor HP	1	1	1	1
Motor RPM	3/4	3/4	3/4	3/4
Motor Frame Size	1075	1075	1075	1075
	48	48	48	48
Filter—Type				
Furnished	Field Supplied	Field Supplied	Field Supplied	Field Supplied
(NO.) Size Recommended in. [mm x mm x mm]	No	No	No	No
	(1)1x24x24 [25x610x610]	(1)1x24x24 [25x610x610]	(1)1x24x24 [25x610x610]	(1)1x24x24 [25x610x610]
Refrigerant Charge Oz. [g]				
	61.3 [1738]	61.3 [1738]	85.3 [2418]	85.3 [2418]
Weights				
Net Weight lbs. [kg]	445 [202]	445 [202]	492 [223]	492 [223]
Ship Weight lbs. [kg]	455 [206]	455 [206]	502 [228]	502 [228]

See Page 14 for Notes.

[] Designates Metric Conversions



NOMINAL SIZES 2-5 TONS [7.0-17.6 kW]

Model RACA15 Series	060ACT***AA	060AJT***AA
Cooling Performance¹		
Gross Cooling Capacity (2nd Stage) Btu [kW]	59,500 [17.43]	59,500 [17.43]
SEER ²	15	15
EER (1st Stage / 2nd Stage)	20.9/11.4	20.9/11.4
AHRI Rated CFM (1st / 2nd Stage) [L/s]	1250/1850 [590/873]	1250/1850 [590/873]
AHRI Net Cooling Capacity (1st / 2nd Stage) Btu [kW]	49,500/57,000 [14.5/16.7]	49,500/57,000 [14.5/16.7]
Net Sensible Capacity (1st / 2nd Stage) Btu [kW]	33,800/40,700 [9.9/11.92]	33,800/40,700 [9.9/11.92]
Net Latent Capacity (1st / 2nd Stage) Btu [kW]	15,700/16,300 [4.6/4.78]	15,700/16,300 [4.6/4.78]
Net System Power (1st / 2nd Stage) kW	2.14/5.02	2.14/5.02
Compressor		
No./Type	1 / Scroll	1 / Scroll
Outdoor Sound Rating (dB)³		
	78	78
Outdoor Coil—Fin Type		
	Louvered	Louvered
Tube Type	MicroChannel	MicroChannel
MicroChannel Depth in. [mm]	1 [25.4]	1 [25.4]
Face Area sq. ft. [sq. m]	15.3 [1.42]	15.3 [1.42]
Rows / FPI [FPcm]	1 / 23 [9]	1 / 23 [9]
Indoor Coil—Fin Type		
	Louvered	Louvered
Tube Type	MicroChannel	MicroChannel
MicroChannel Depth in. [mm]	1.26 [32]	1.26 [32]
Face Area sq. ft. [sq. m]	4 [0.37]	4 [0.37]
Rows / FPI [FPcm]	1 / 20 [8]	1 / 20 [8]
Refrigerant Control	TX Valves	TX Valves
Drain Connection No./Size in. [mm]	1/0.75 [19.05]	1/0.75 [19.05]
Outdoor Fan—Type		
	Propeller	Propeller
No. Used/Diameter in. [mm]	1/22 [558.8]	1/22 [558.8]
Drive Type/No. Speeds	Direct/1	Direct/1
CFM [L/s]	3300 [1557]	3300 [1557]
No. Motors/HP	1 at 13 HP	1 at 13 HP
Motor RPM	1075	1075
Indoor Fan—Type		
	FC Centrifugal	FC Centrifugal
No. Used/Diameter in. [mm]	1/12x9 [305x229]	1/12x9 [305x229]
Drive Type	Direct	Direct
No. Speeds	Multiple	Multiple
No. Motors	1	1
Motor HP	1	1
Motor RPM	1075	1075
Motor Frame Size	48	48
Filter—Type		
	Field Supplied	Field Supplied
Furnished	No	No
(NO.) Size Recommended in. [mm x mm x mm]	(1)1x24x30 [25x610x762]	(1)1x24x30 [25x610x762]
Refrigerant Charge Oz. [g]		
	89.6 [2540]	89.6 [2540]
Weights		
Net Weight lbs. [kg]	515 [234]	515 [234]
Ship Weight lbs. [kg]	525 [238]	525 [238]

See Page 14 for Notes.

[] Designates Metric Conversions



NOTES:

1. Cooling Performance is rated at 95° F ambient, 80° F entering dry bulb, 67° F entering wet bulb. Gross capacity does not include the effect of fan motor heat. AHRI capacity is net and includes the effect of fan motor heat. Units are suitable for operation in CFM range shown in airflow tables. Units are certified in accordance with the Unitary Air Conditioner Equipment certification program, which is based on AHRI Standard 210/240.
2. EER and/or SEER are rated at AHRI conditions and in accordance with DOE test procedures.
3. Outdoor Sound Rating shown is tested in accordance with AHRI Standard 270.





GROSS SYSTEMS PERFORMANCE DATA – RACA14024A

ENTERING INDOOR AIR @ 80°F [26.7°C] dbE ①											
wbE		71°F [21.7°C]			67°F [19.4°C]			63°F [17.2°C]			
CFM [L/s]		990 [467]	900 [425]	760 [359]	990 [467]	900 [425]	760 [359]	990 [467]	900 [425]	760 [359]	
DR ①		0.21	0.19	0.15	0.21	0.19	0.15	0.21	0.19	0.15	
OUTDOOR DRY BULB TEMPERATURE °F [°C]	75 [23.9]	Total BTUH [kW] Sens BTUH [kW] Power	30.9 [9.1] 18.7 [5.5] 1.4	30.4 [8.9] 17.9 [5.2] 1.4	29.5 [8.7] 16.6 [4.9] 1.4	29.1 [8.5] 21.9 [6.4] 1.4	28.6 [8.4] 20.9 [6.1] 1.4	27.8 [8.1] 19.4 [5.7] 1.4	27.5 [8.1] 24.6 [7.2] 1.4	27.0 [7.9] 23.5 [6.9] 1.4	26.2 [7.7] 21.8 [6.4] 1.4
	80 [26.7]	Total BTUH [kW] Sens BTUH [kW] Power	30.0 [8.8] 18.2 [5.3] 1.5	29.4 [8.6] 17.4 [5.1] 1.5	28.6 [8.4] 16.1 [4.7] 1.5	28.1 [8.2] 21.4 [6.3] 1.5	27.6 [8.1] 20.4 [6.0] 1.5	26.8 [7.9] 18.9 [5.5] 1.5	26.5 [7.8] 24.0 [7.0] 1.5	26.0 [7.6] 23.0 [6.7] 1.5	25.3 [7.4] 21.3 [6.2] 1.5
	85 [29.4]	Total BTUH [kW] Sens BTUH [kW] Power	29.0 [8.5] 17.6 [5.2] 1.6	28.5 [8.3] 16.8 [4.9] 1.6	27.7 [8.1] 15.6 [4.6] 1.6	27.1 [8.0] 20.8 [6.1] 1.6	26.7 [7.8] 19.9 [5.8] 1.6	25.9 [7.6] 18.4 [5.4] 1.6	25.5 [7.5] 23.5 [6.9] 1.6	25.1 [7.3] 22.4 [6.6] 1.6	24.4 [7.1] 20.8 [6.1] 1.6
	90 [32.2]	Total BTUH [kW] Sens BTUH [kW] Power	28.0 [8.2] 17.0 [5.0] 1.7	27.5 [8.1] 16.3 [4.8] 1.7	26.7 [7.8] 15.1 [4.4] 1.7	26.1 [7.7] 20.2 [5.9] 1.7	25.7 [7.5] 19.3 [5.7] 1.7	25.0 [7.3] 17.9 [5.3] 1.7	24.5 [7.2] 22.9 [6.7] 1.7	24.1 [7.1] 21.9 [6.4] 1.7	23.4 [6.9] 20.3 [5.9] 1.7
	95 [35]	Total BTUH [kW] Sens BTUH [kW] Power	27.0 [7.9] 16.5 [4.8] 1.9	26.5 [7.8] 15.7 [4.6] 1.8	25.7 [7.5] 14.6 [4.3] 1.8	25.1 [7.4] 19.7 [5.8] 1.8	24.7 [7.2] 18.8 [5.5] 1.8	24.0 [7.0] 17.4 [5.1] 1.8	23.5 [6.9] 22.3 [6.5] 1.8	23.1 [6.8] 21.3 [6.2] 1.8	22.4 [6.6] 19.8 [5.8] 1.8
	100 [37.8]	Total BTUH [kW] Sens BTUH [kW] Power	25.9 [7.6] 15.9 [4.6] 2.0	25.5 [7.5] 15.2 [4.4] 2.0	24.8 [7.3] 14.1 [4.1] 1.9	24.1 [7.1] 19.1 [5.6] 2.0	23.7 [6.9] 18.2 [5.3] 2.0	23.0 [6.7] 16.9 [5.0] 1.9	22.5 [6.6] 21.7 [6.4] 2.0	22.1 [6.5] 20.8 [6.1] 1.9	21.5 [6.3] 19.2 [5.6] 1.9
	105 [40.6]	Total BTUH [kW] Sens BTUH [kW] Power	24.9 [7.3] 15.3 [4.5] 2.1	24.5 [7.2] 14.6 [4.3] 2.1	23.8 [7.0] 13.5 [4.0] 2.1	23.1 [6.8] 18.5 [5.4] 2.1	22.6 [6.6] 17.7 [5.2] 2.1	22.0 [6.4] 16.4 [4.8] 2.1	21.4 [6.3] 21.1 [6.2] 2.1	21.1 [6.2] 20.2 [5.9] 2.1	20.5 [6.0] 18.7 [5.5] 2.0
	110 [43.3]	Total BTUH [kW] Sens BTUH [kW] Power	23.8 [7.0] 14.7 [4.3] 2.3	23.4 [6.9] 14.0 [4.1] 2.2	22.7 [6.7] 13.0 [3.8] 2.2	22.0 [6.4] 17.9 [5.2] 2.2	21.6 [6.3] 17.1 [5.0] 2.2	21.0 [6.1] 15.8 [4.6] 2.2	20.4 [6.0] 20.4 [6.0] 2.2	20.0 [5.9] 19.6 [5.7] 2.2	19.4 [5.7] 18.2 [5.3] 2.2
	115 [46.1]	Total BTUH [kW] Sens BTUH [kW] Power	22.8 [6.7] 14.1 [4.1] 2.4	22.3 [6.5] 13.4 [3.9] 2.4	21.7 [6.4] 12.5 [3.6] 2.3	20.9 [6.1] 17.3 [5.1] 2.4	20.5 [6.0] 16.5 [4.8] 2.4	19.9 [5.8] 15.3 [4.5] 2.3	19.3 [5.7] 19.3 [5.7] 2.4	18.9 [5.6] 18.9 [5.6] 2.4	18.4 [5.4] 17.6 [5.2] 2.3
	120 [48.9]	Total BTUH [kW] Sens BTUH [kW] Power	21.7 [6.3] 13.4 [3.9] 2.6	21.3 [6.2] 12.8 [3.8] 2.5	20.7 [6.1] 11.9 [3.5] 2.5	19.8 [5.8] 16.6 [4.9] 2.5	19.5 [5.7] 15.9 [4.7] 2.5	18.9 [5.5] 14.7 [4.3] 2.5	18.2 [5.3] 18.2 [5.3] 2.5	17.9 [5.2] 17.9 [5.2] 2.5	17.4 [5.1] 17.1 [5.0] 2.5
	125 [51.7]	Total BTUH [kW] Sens BTUH [kW] Power	20.5 [6.0] 12.8 [3.8] 2.7	20.2 [5.9] 12.2 [3.6] 2.7	19.6 [5.7] 11.3 [3.3] 2.7	18.7 [5.5] 16.0 [4.7] 2.7	18.4 [5.4] 15.3 [4.5] 2.7	17.8 [5.2] 14.2 [4.2] 2.7	17.1 [5.0] 17.1 [5.0] 2.7	16.8 [4.9] 16.8 [4.9] 2.7	16.3 [4.8] 16.3 [4.8] 2.6

DR —Depression ratio
dbE —Entering air dry bulb
wbE—Entering air wet bulb

Total —Total capacity x 1000 BTUH
Sens —Sensible capacity x 1000 BTUH
Power —KW input

NOTES: ① When the entering air dry bulb is other than 80°F [27°C], adjust the sensible capacity from the table by adding $[1.10 \times \text{CFM} \times (1 - \text{DR}) \times (\text{dbE} - 80)]$.

[] Designates Metric Conversions





GROSS SYSTEMS PERFORMANCE DATA—RACA14030A

ENTERING INDOOR AIR @ 80°F [26.7°C] dbE ①											
wbE		71°F [21.7°C]			67°F [19.4°C]			63°F [17.2°C]			
CFM [L/s]		1100 [519]	1000 [472]	850 [401]	1100 [519]	1000 [472]	850 [401]	1100 [519]	1000 [472]	850 [401]	
DR ①		0.16	0.15	0.11	0.16	0.15	0.11	0.16	0.15	0.11	
OUTDOOR DRY BULB TEMPERATURE °F [°C]	75 [23.9]	Total BTUH [kW] Sens BTUH [kW] Power	37.0 [10.9] 21.6 [6.3] 1.7	36.4 [10.7] 20.6 [6.0] 1.6	35.4 [10.4] 19.2 [5.6] 1.6	35.0 [10.3] 25.6 [7.5] 1.7	34.4 [10.1] 24.4 [7.2] 1.6	33.4 [9.8] 22.7 [6.7] 1.6	33.2 [9.7] 28.8 [8.4] 1.6	32.6 [9.6] 27.5 [8.1] 1.6	31.7 [9.3] 25.6 [7.5] 1.6
	80 [26.7]	Total BTUH [kW] Sens BTUH [kW] Power	36.0 [10.5] 21.1 [6.2] 1.7	35.4 [10.4] 20.1 [5.9] 1.7	34.4 [10.1] 18.7 [5.5] 1.7	33.9 [9.9] 25.1 [7.4] 1.7	33.3 [9.8] 24.0 [7.0] 1.7	32.4 [9.5] 22.3 [6.5] 1.7	32.2 [9.4] 28.3 [8.3] 1.7	31.6 [9.3] 27.0 [7.9] 1.7	30.7 [9.0] 25.1 [7.4] 1.7
	85 [29.4]	Total BTUH [kW] Sens BTUH [kW] Power	34.9 [10.2] 20.6 [6.0] 1.8	34.3 [10.1] 19.7 [5.8] 1.8	33.4 [9.8] 18.3 [5.4] 1.8	32.9 [9.6] 24.6 [7.2] 1.8	32.3 [9.5] 23.5 [6.9] 1.8	31.4 [9.2] 21.8 [6.4] 1.8	31.1 [9.1] 27.8 [8.1] 1.8	30.6 [9.0] 26.5 [7.8] 1.8	29.7 [8.7] 24.7 [7.2] 1.8
	90 [32.2]	Total BTUH [kW] Sens BTUH [kW] Power	33.9 [9.9] 20.1 [5.9] 1.9	33.3 [9.7] 19.2 [5.6] 1.9	32.3 [9.5] 17.8 [5.2] 1.9	31.8 [9.3] 24.1 [7.1] 1.9	31.2 [9.2] 23.0 [6.7] 1.9	30.4 [8.9] 21.4 [6.3] 1.9	30.0 [8.8] 27.3 [8.0] 1.9	29.5 [8.6] 26.0 [7.6] 1.9	28.7 [8.4] 24.2 [7.1] 1.9
	95 [35]	Total BTUH [kW] Sens BTUH [kW] Power	32.8 [9.6] 19.5 [5.7] 2.1	32.2 [9.4] 18.6 [5.5] 2.0	31.3 [9.2] 17.3 [5.1] 2.0	30.7 [9.0] 23.5 [6.9] 2.0	30.2 [8.8] 22.5 [6.6] 2.0	29.3 [8.6] 20.9 [6.1] 2.0	28.9 [8.5] 26.7 [7.8] 2.0	28.4 [8.3] 25.5 [7.5] 2.0	27.6 [8.1] 23.7 [7.0] 2.0
	100 [37.8]	Total BTUH [kW] Sens BTUH [kW] Power	31.6 [9.3] 18.9 [5.5] 2.2	31.1 [9.1] 18.1 [5.3] 2.2	30.2 [8.9] 16.8 [4.9] 2.1	29.6 [8.7] 22.9 [6.7] 2.2	29.1 [8.5] 21.9 [6.4] 2.1	28.3 [8.3] 20.4 [6.0] 2.1	27.8 [8.2] 26.1 [7.7] 2.2	27.3 [8.0] 25.0 [7.3] 2.1	26.6 [7.8] 23.2 [6.8] 2.1
	105 [40.6]	Total BTUH [kW] Sens BTUH [kW] Power	30.5 [8.9] 18.3 [5.4] 2.3	30.0 [8.8] 17.5 [5.1] 2.3	29.2 [8.5] 16.3 [4.8] 2.3	28.5 [8.3] 22.3 [6.5] 2.3	28.0 [8.2] 21.3 [6.2] 2.3	27.2 [8.0] 19.8 [5.8] 2.2	26.7 [7.8] 25.5 [7.5] 2.3	26.2 [7.7] 24.4 [7.1] 2.3	25.5 [7.5] 22.7 [6.6] 2.2
	110 [43.3]	Total BTUH [kW] Sens BTUH [kW] Power	29.4 [8.6] 17.7 [5.2] 2.4	28.8 [8.5] 16.9 [5.0] 2.4	28.1 [8.2] 15.7 [4.6] 2.4	27.3 [8.0] 21.7 [6.4] 2.4	26.8 [7.9] 20.7 [6.1] 2.4	26.1 [7.6] 19.3 [5.6] 2.4	25.5 [7.5] 24.9 [7.3] 2.4	25.1 [7.4] 23.8 [7.0] 2.4	24.4 [7.2] 22.1 [6.5] 2.4
	115 [46.1]	Total BTUH [kW] Sens BTUH [kW] Power	28.2 [8.3] 17.0 [5.0] 2.6	27.7 [8.1] 16.3 [4.8] 2.6	26.9 [7.9] 15.1 [4.4] 2.5	26.1 [7.7] 21.0 [6.2] 2.6	25.7 [7.5] 20.1 [5.9] 2.6	25.0 [7.3] 18.7 [5.5] 2.5	24.4 [7.1] 24.2 [7.1] 2.6	23.9 [7.0] 23.1 [6.8] 2.5	23.3 [6.8] 21.5 [6.3] 2.5
	120 [48.9]	Total BTUH [kW] Sens BTUH [kW] Power	27.0 [7.9] 16.3 [4.8] 2.7	26.5 [7.8] 15.6 [4.6] 2.7	25.8 [7.6] 14.5 [4.3] 2.7	25.0 [7.3] 20.3 [6.0] 2.7	24.5 [7.2] 19.4 [5.7] 2.7	23.9 [7.0] 18.1 [5.3] 2.7	23.2 [6.8] 23.2 [6.8] 2.7	22.8 [6.7] 22.5 [6.6] 2.7	22.2 [6.5] 20.9 [6.1] 2.7
	125 [51.7]	Total BTUH [kW] Sens BTUH [kW] Power	25.8 [7.6] 15.6 [4.6] 2.9	25.4 [7.4] 14.9 [4.4] 2.9	24.7 [7.2] 13.9 [4.1] 2.8	23.8 [7.0] 19.6 [5.8] 2.9	23.3 [6.8] 18.8 [5.5] 2.9	22.7 [6.7] 17.4 [5.1] 2.8	22.0 [6.4] 22.0 [6.4] 2.9	21.6 [6.3] 21.6 [6.3] 2.9	21.0 [6.2] 20.3 [5.9] 2.8

DR —Depression ratio
dbE —Entering air dry bulb
wbE—Entering air wet bulb

Total —Total capacity x 1000 BTUH
Sens —Sensible capacity x 1000 BTUH
Power —kW input

NOTES: ① When the entering air dry bulb is other than 80°F [27°C], adjust the sensible capacity from the table by adding [1.10 x CFM x (1 – DR) x (dbE – 80)].

[] Designates Metric Conversions





GROSS SYSTEMS PERFORMANCE DATA – RACA14036A

ENTERING INDOOR AIR @ 80°F [26.7°C] dbE ①											
wbE		71°F [21.7°C]			67°F [19.4°C]			63°F [17.2°C]			
CFM [L/s]		1320 [623]	1200 [566]	1020 [481]	1320 [623]	1200 [566]	1020 [481]	1320 [623]	1200 [566]	1020 [481]	
DR ①		0.23	0.21	0.18	0.23	0.21	0.18	0.23	0.21	0.18	
OUTDOOR DRY BULB TEMPERATURE °F [°C]	75 [23.9]	Total BTUH [kW] Sens BTUH [kW] Power	44.3 [13.0] 25.4 [7.4] 2.0	43.5 [12.8] 24.2 [7.1] 2.0	42.3 [12.4] 22.5 [6.6] 2.0	41.4 [12.1] 29.6 [8.7] 2.0	40.6 [11.9] 28.3 [8.3] 2.0	39.5 [11.6] 26.3 [7.7] 2.0	38.3 [11.2] 32.8 [9.6] 2.0	37.6 [11.0] 31.3 [9.2] 2.0	36.6 [10.7] 29.1 [8.5] 2.0
	80 [26.7]	Total BTUH [kW] Sens BTUH [kW] Power	43.0 [12.6] 24.7 [7.2] 2.1	42.2 [12.4] 23.6 [6.9] 2.1	41.1 [12.0] 21.9 [6.4] 2.1	40.0 [11.7] 28.9 [8.5] 2.1	39.3 [11.5] 27.6 [8.1] 2.1	38.2 [11.2] 25.7 [7.5] 2.1	37.0 [10.8] 32.1 [9.4] 2.1	36.3 [10.6] 30.7 [9.0] 2.1	35.3 [10.3] 28.5 [8.4] 2.1
	85 [29.4]	Total BTUH [kW] Sens BTUH [kW] Power	41.7 [12.2] 24.0 [7.0] 2.3	40.9 [12.0] 22.9 [6.7] 2.2	39.8 [11.7] 21.3 [6.2] 2.2	38.7 [11.3] 28.2 [8.3] 2.2	38.0 [11.1] 27.0 [7.9] 2.2	37.0 [10.8] 25.1 [7.3] 2.2	35.6 [10.4] 31.4 [9.2] 2.2	35.0 [10.3] 30.0 [8.8] 2.2	34.0 [10.0] 27.9 [8.2] 2.2
	90 [32.2]	Total BTUH [kW] Sens BTUH [kW] Power	40.3 [11.8] 23.2 [6.8] 2.4	39.6 [11.6] 22.2 [6.5] 2.4	38.5 [11.3] 20.7 [6.1] 2.3	37.3 [10.9] 27.5 [8.1] 2.4	36.7 [10.7] 26.3 [7.7] 2.4	35.7 [10.5] 24.4 [7.2] 2.3	34.3 [10.0] 30.7 [9.0] 2.4	33.7 [9.9] 29.3 [8.6] 2.4	32.7 [9.6] 27.3 [8.0] 2.3
	95 [35]	Total BTUH [kW] Sens BTUH [kW] Power	38.9 [11.4] 22.5 [6.6] 2.5	38.3 [11.2] 21.5 [6.3] 2.5	37.2 [10.9] 20.0 [5.9] 2.5	36.0 [10.5] 26.7 [7.8] 2.5	35.3 [10.4] 25.5 [7.5] 2.5	34.4 [10.1] 23.7 [7.0] 2.5	32.9 [9.6] 29.9 [8.8] 2.5	32.3 [9.5] 28.6 [8.4] 2.5	31.4 [9.2] 26.6 [7.8] 2.5
	100 [37.8]	Total BTUH [kW] Sens BTUH [kW] Power	37.6 [11.0] 21.7 [6.4] 2.7	36.9 [10.8] 20.7 [6.1] 2.7	35.9 [10.5] 19.3 [5.7] 2.6	34.6 [10.1] 25.9 [7.6] 2.7	34.0 [10.0] 24.8 [7.3] 2.7	33.0 [9.7] 23.0 [6.8] 2.6	31.5 [9.2] 29.1 [8.5] 2.7	30.9 [9.1] 27.8 [8.2] 2.6	30.1 [8.8] 25.9 [7.6] 2.6
	105 [40.6]	Total BTUH [kW] Sens BTUH [kW] Power	36.1 [10.6] 20.9 [6.1] 2.9	35.5 [10.4] 20.0 [5.8] 2.8	34.5 [10.1] 18.6 [5.4] 2.8	33.2 [9.7] 25.1 [7.4] 2.8	32.6 [9.5] 24.0 [7.0] 2.8	31.7 [9.3] 22.3 [6.5] 2.8	30.1 [8.8] 28.3 [8.3] 2.8	29.6 [8.7] 27.1 [7.9] 2.8	28.7 [8.4] 25.2 [7.4] 2.8
	110 [43.3]	Total BTUH [kW] Sens BTUH [kW] Power	34.7 [10.2] 20.1 [5.9] 3.0	34.1 [10.0] 19.2 [5.6] 3.0	33.2 [9.7] 17.8 [5.2] 3.0	31.7 [9.3] 24.3 [7.1] 3.0	31.2 [9.1] 23.2 [6.8] 3.0	30.3 [8.9] 21.6 [6.3] 3.0	28.7 [8.4] 27.5 [8.1] 3.0	28.2 [8.3] 26.3 [7.7] 3.0	27.4 [8.0] 24.4 [7.2] 3.0
	115 [46.1]	Total BTUH [kW] Sens BTUH [kW] Power	33.3 [9.8] 19.2 [5.6] 3.2	32.7 [9.6] 18.3 [5.4] 3.2	31.8 [9.3] 17.0 [5.0] 3.2	30.3 [8.9] 23.4 [6.9] 3.2	29.8 [8.7] 22.4 [6.6] 3.2	28.9 [8.5] 20.8 [6.1] 3.2	27.2 [8.0] 26.6 [7.8] 3.2	26.7 [7.8] 25.4 [7.5] 3.2	26.0 [7.6] 23.7 [6.9] 3.1
	120 [48.9]	Total BTUH [kW] Sens BTUH [kW] Power	31.8 [9.3] 18.3 [5.4] 3.4	31.2 [9.2] 17.5 [5.1] 3.4	30.4 [8.9] 16.3 [4.8] 3.4	28.8 [8.5] 22.5 [6.6] 3.4	28.3 [8.3] 21.5 [6.3] 3.4	27.5 [8.1] 20.0 [5.9] 3.4	25.8 [7.5] 25.7 [7.5] 3.4	25.3 [7.4] 24.6 [7.2] 3.4	24.6 [7.2] 22.9 [6.7] 3.3
	125 [51.7]	Total BTUH [kW] Sens BTUH [kW] Power	30.3 [8.9] 17.4 [5.1] 3.6	29.8 [8.7] 16.6 [4.9] 3.6	29.0 [8.5] 15.4 [4.5] 3.6	27.4 [8.0] 21.6 [6.3] 3.6	26.9 [7.9] 20.7 [6.1] 3.6	26.1 [7.7] 19.2 [5.6] 3.6	24.3 [7.1] 24.3 [7.1] 3.6	23.8 [7.0] 23.7 [6.9] 3.6	23.2 [6.8] 22.0 [6.5] 3.6

DR —Depression ratio
dbE —Entering air dry bulb
wbE—Entering air wet bulb

Total —Total capacity x 1000 BTUH
Sens —Sensible capacity x 1000 BTUH
Power —KW input

NOTES: ① When the entering air dry bulb is other than 80°F [27°C], adjust the sensible capacity from the table by adding $[1.10 \times \text{CFM} \times (1 - \text{DR}) \times (\text{dbE} - 80)]$.

[] Designates Metric Conversions





GROSS SYSTEMS PERFORMANCE DATA—RACA14042A

		ENTERING INDOOR AIR @ 80°F [26.7°C] dbE ①									
wbE		71°F [21.7°C]			67°F [19.4°C]			63°F [17.2°C]			
CFM [L/s]		1430 [675]	1300 [614]	1100 [519]	1430 [675]	1300 [614]	1100 [519]	1430 [675]	1300 [614]	1100 [519]	
DR ①		0.15	0.14	0.1	0.15	0.14	0.1	0.15	0.14	0.1	
OUTDOOR DRY BULB TEMPERATURE °F [°C]	75 [23.9]	Total BTUH [kW] Sens BTUH [kW] Power	50.0 [14.7] 29.2 [8.5] 2.4	49.1 [14.4] 27.9 [8.2] 2.4	47.7 [14.0] 25.9 [7.6] 2.3	47.3 [13.9] 34.3 [10.0] 2.4	46.4 [13.6] 32.7 [9.6] 2.3	45.1 [13.2] 30.4 [8.9] 2.3	44.3 [13.0] 38.5 [11.3] 2.3	43.5 [12.8] 36.8 [10.8] 2.3	42.3 [12.4] 34.2 [10.0] 2.3
	80 [26.7]	Total BTUH [kW] Sens BTUH [kW] Power	48.7 [14.3] 28.5 [8.4] 2.5	47.9 [14.0] 27.3 [8.0] 2.5	46.5 [13.6] 25.3 [7.4] 2.5	46.0 [13.5] 33.7 [9.9] 2.5	45.2 [13.2] 32.2 [9.4] 2.5	43.9 [12.9] 29.8 [8.7] 2.4	43.0 [12.6] 37.9 [11.1] 2.5	42.3 [12.4] 36.2 [10.6] 2.5	41.1 [12.0] 33.6 [9.9] 2.4
	85 [29.4]	Total BTUH [kW] Sens BTUH [kW] Power	47.4 [13.9] 27.9 [8.2] 2.7	46.6 [13.6] 26.6 [7.8] 2.6	45.2 [13.3] 24.7 [7.2] 2.6	44.7 [13.1] 33.0 [9.7] 2.6	43.9 [12.9] 31.5 [9.2] 2.6	42.6 [12.5] 29.3 [8.6] 2.6	41.7 [12.2] 37.2 [10.9] 2.6	41.0 [12.0] 35.6 [10.4] 2.6	39.8 [11.7] 33.0 [9.7] 2.6
	90 [32.2]	Total BTUH [kW] Sens BTUH [kW] Power	46.0 [13.5] 27.2 [8.0] 2.8	45.2 [13.2] 26.0 [7.6] 2.8	43.9 [12.9] 24.1 [7.1] 2.8	43.3 [12.7] 32.3 [9.5] 2.8	42.5 [12.5] 30.8 [9.0] 2.8	41.3 [12.1] 28.6 [8.4] 2.7	40.3 [11.8] 36.5 [10.7] 2.8	39.6 [11.6] 34.9 [10.2] 2.8	38.5 [11.3] 32.4 [9.5] 2.7
	95 [35]	Total BTUH [kW] Sens BTUH [kW] Power	44.6 [13.1] 26.4 [7.7] 3.0	43.8 [12.8] 25.2 [7.4] 3.0	42.6 [12.5] 23.4 [6.9] 2.9	41.8 [12.3] 31.5 [9.2] 3.0	41.1 [12.0] 30.1 [8.8] 3.0	39.9 [11.7] 27.9 [8.2] 2.9	38.9 [11.4] 35.8 [10.5] 3.0	38.2 [11.2] 34.2 [10.0] 2.9	37.1 [10.9] 31.7 [9.3] 2.9
	100 [37.8]	Total BTUH [kW] Sens BTUH [kW] Power	43.1 [12.6] 25.6 [7.5] 3.2	42.3 [12.4] 24.4 [7.2] 3.1	41.1 [12.1] 22.7 [6.6] 3.1	40.4 [11.8] 30.7 [9.0] 3.2	39.6 [11.6] 29.3 [8.6] 3.1	38.5 [11.3] 27.2 [8.0] 3.1	37.4 [11.0] 34.9 [10.2] 3.1	36.7 [10.8] 33.4 [9.8] 3.1	35.7 [10.5] 31.0 [9.1] 3.1
	105 [40.6]	Total BTUH [kW] Sens BTUH [kW] Power	41.6 [12.2] 24.7 [7.2] 3.4	40.8 [12.0] 23.6 [6.9] 3.3	39.7 [11.6] 21.9 [6.4] 3.3	38.8 [11.4] 29.8 [8.7] 3.3	38.1 [11.2] 28.5 [8.3] 3.3	37.1 [10.9] 26.4 [7.7] 3.3	35.9 [10.5] 34.1 [10.0] 3.3	35.2 [10.3] 32.5 [9.5] 3.3	34.3 [10.0] 30.2 [8.8] 3.3
	110 [43.3]	Total BTUH [kW] Sens BTUH [kW] Power	40.0 [11.7] 23.8 [7.0] 3.6	39.3 [11.5] 22.7 [6.7] 3.5	38.2 [11.2] 21.1 [6.2] 3.5	37.2 [10.9] 28.9 [8.5] 3.5	36.6 [10.7] 27.6 [8.1] 3.5	35.6 [10.4] 25.6 [7.5] 3.5	34.3 [10.0] 33.1 [9.7] 3.5	33.7 [9.9] 31.6 [9.3] 3.5	32.7 [9.6] 29.4 [8.6] 3.5
	115 [46.1]	Total BTUH [kW] Sens BTUH [kW] Power	38.3 [11.2] 22.8 [6.7] 3.8	37.7 [11.0] 21.8 [6.4] 3.7	36.6 [10.7] 20.2 [5.9] 3.7	35.6 [10.4] 27.9 [8.2] 3.8	35.0 [10.2] 26.6 [7.8] 3.7	34.0 [10.0] 24.7 [7.2] 3.7	32.7 [9.6] 32.1 [9.4] 3.7	32.1 [9.4] 30.7 [9.0] 3.7	31.2 [9.1] 28.5 [8.4] 3.7
	120 [48.9]	Total BTUH [kW] Sens BTUH [kW] Power	36.7 [10.7] 21.7 [6.4] 4.0	36.0 [10.6] 20.8 [6.1] 4.0	35.0 [10.3] 19.3 [5.6] 3.9	33.9 [9.9] 26.8 [7.9] 4.0	33.3 [9.8] 25.6 [7.5] 3.9	32.4 [9.5] 23.8 [7.0] 3.9	31.0 [9.1] 31.0 [9.1] 4.0	30.4 [8.9] 29.7 [8.7] 3.9	29.6 [8.7] 27.6 [8.1] 3.9
125 [51.7]	Total BTUH [kW] Sens BTUH [kW] Power	34.9 [10.2] 20.6 [6.1] 4.2	34.3 [10.1] 19.7 [5.8] 4.2	33.3 [9.8] 18.3 [5.4] 4.1	32.2 [9.4] 25.8 [7.5] 4.2	31.6 [9.3] 24.6 [7.2] 4.2	30.7 [9.0] 22.8 [6.7] 4.1	29.2 [8.6] 29.2 [8.6] 4.2	28.7 [8.4] 28.7 [8.4] 4.1	27.9 [8.2] 26.6 [7.8] 4.1	

DR —Depression ratio
dbE —Entering air dry bulb
wbE—Entering air wet bulb

Total —Total capacity x 1000 BTUH
Sens —Sensible capacity x 1000 BTUH
Power —KW input

NOTES: ① When the entering air dry bulb is other than 80°F [27°C], adjust the sensible capacity from the table by adding [1.10 x CFM x (1 - DR) x (dbE - 80)].

[] Designates Metric Conversions





GROSS SYSTEMS PERFORMANCE DATA – RACA14048A

		ENTERING INDOOR AIR @ 80°F [26.7°C] dbE ①									
		71°F [21.7°C]			67°F [19.4°C]			63°F [17.2°C]			
wbE		1700 [802]	1550 [732]	1320 [623]	1700 [802]	1550 [732]	1320 [623]	1700 [802]	1550 [732]	1320 [623]	
CFM [L/s]		1700 [802]	1550 [732]	1320 [623]	1700 [802]	1550 [732]	1320 [623]	1700 [802]	1550 [732]	1320 [623]	
DR ①		0.21	0.19	0.17	0.21	0.19	0.17	0.21	0.19	0.17	
OUTDOOR DRY BULB TEMPERATURE °F [°C]	75 [23.9]	Total BTUH [kW] Sens BTUH [kW] Power	58.8 [17.2] 33.0 [9.7] 2.8	57.8 [16.9] 31.6 [9.3] 2.8	56.3 [16.5] 29.4 [8.6] 2.7	55.4 [16.2] 39.1 [11.5] 2.8	54.4 [15.9] 37.4 [11.0] 2.7	53.0 [15.5] 34.8 [10.2] 2.7	52.6 [15.4] 45.0 [13.2] 2.7	51.7 [15.1] 43.0 [12.6] 2.7	50.3 [14.7] 40.1 [11.7] 2.7
	80 [26.7]	Total BTUH [kW] Sens BTUH [kW] Power	57.1 [16.7] 32.2 [9.4] 2.9	56.1 [16.4] 30.8 [9.0] 2.9	54.6 [16.0] 28.7 [8.4] 2.9	53.6 [15.7] 38.3 [11.2] 2.9	52.7 [15.4] 36.6 [10.7] 2.9	51.3 [15.0] 34.1 [10.0] 2.9	50.8 [14.9] 44.2 [12.9] 2.9	49.9 [14.6] 42.3 [12.4] 2.9	48.6 [14.2] 39.3 [11.5] 2.8
	85 [29.4]	Total BTUH [kW] Sens BTUH [kW] Power	55.3 [16.2] 31.4 [9.2] 3.1	54.4 [15.9] 30.0 [8.8] 3.1	52.9 [15.5] 27.9 [8.2] 3.0	51.9 [15.2] 37.4 [11.0] 3.1	51.0 [14.9] 35.8 [10.5] 3.1	49.6 [14.5] 33.3 [9.8] 3.0	49.1 [14.4] 43.3 [12.7] 3.1	48.2 [14.1] 41.4 [12.1] 3.0	46.9 [13.7] 38.6 [11.3] 3.0
	90 [32.2]	Total BTUH [kW] Sens BTUH [kW] Power	53.6 [15.7] 30.4 [8.9] 3.3	52.6 [15.4] 29.1 [8.5] 3.3	51.2 [15.0] 27.1 [7.9] 3.2	50.1 [14.7] 36.5 [10.7] 3.3	49.2 [14.4] 34.9 [10.2] 3.2	47.9 [14.0] 32.5 [9.5] 3.2	47.3 [13.9] 42.4 [12.4] 3.2	46.5 [13.6] 40.6 [11.9] 3.2	45.2 [13.3] 37.8 [11.1] 3.2
	95 [35]	Total BTUH [kW] Sens BTUH [kW] Power	51.8 [15.2] 29.5 [8.6] 3.5	50.9 [14.9] 28.2 [8.3] 3.5	49.5 [14.5] 26.3 [7.7] 3.4	48.4 [14.2] 35.6 [10.4] 3.5	47.5 [13.9] 34.0 [10.0] 3.4	46.3 [13.6] 31.7 [9.3] 3.4	45.6 [13.4] 41.5 [12.1] 3.4	44.8 [13.1] 39.7 [11.6] 3.4	43.6 [12.8] 36.9 [10.8] 3.4
	100 [37.8]	Total BTUH [kW] Sens BTUH [kW] Power	50.1 [14.7] 28.5 [8.4] 3.7	49.2 [14.4] 27.3 [8.0] 3.7	47.9 [14.0] 25.4 [7.4] 3.6	46.6 [13.7] 34.6 [10.1] 3.7	45.8 [13.4] 33.1 [9.7] 3.7	44.6 [13.1] 30.8 [9.0] 3.6	43.8 [12.8] 40.5 [11.9] 3.7	43.1 [12.6] 38.7 [11.3] 3.6	41.9 [12.3] 36.0 [10.6] 3.6
	105 [40.6]	Total BTUH [kW] Sens BTUH [kW] Power	48.4 [14.2] 27.5 [8.1] 4.0	47.5 [13.9] 26.3 [7.7] 3.9	46.2 [13.5] 24.5 [7.2] 3.9	44.9 [13.2] 33.6 [9.8] 3.9	44.1 [12.9] 32.1 [9.4] 3.9	42.9 [12.6] 29.9 [8.8] 3.8	42.1 [12.3] 39.4 [11.6] 3.9	41.4 [12.1] 37.7 [11.1] 3.9	40.3 [11.8] 35.1 [10.3] 3.8
	110 [43.3]	Total BTUH [kW] Sens BTUH [kW] Power	46.6 [13.7] 26.4 [7.7] 4.2	45.8 [13.4] 25.3 [7.4] 4.2	44.6 [13.1] 23.5 [6.9] 4.1	43.2 [12.7] 32.5 [9.5] 4.2	42.4 [12.4] 31.1 [9.1] 4.2	41.3 [12.1] 28.9 [8.5] 4.1	40.4 [11.8] 38.4 [11.2] 4.2	39.7 [11.6] 36.7 [10.8] 4.1	38.6 [11.3] 34.2 [10.0] 4.1
	115 [46.1]	Total BTUH [kW] Sens BTUH [kW] Power	44.9 [13.2] 25.3 [7.4] 4.5	44.1 [12.9] 24.2 [7.1] 4.5	42.9 [12.6] 22.6 [6.6] 4.4	41.5 [12.2] 31.4 [9.2] 4.5	40.8 [11.9] 30.0 [8.8] 4.4	39.7 [11.6] 28.0 [8.2] 4.4	38.7 [11.3] 37.3 [10.9] 4.4	38.0 [11.1] 35.7 [10.5] 4.4	37.0 [10.8] 33.2 [9.7] 4.4
	120 [48.9]	Total BTUH [kW] Sens BTUH [kW] Power	43.2 [12.7] 24.2 [7.1] 4.8	42.5 [12.4] 23.1 [6.8] 4.8	41.3 [12.1] 21.5 [6.3] 4.7	39.8 [11.7] 30.3 [8.9] 4.8	39.1 [11.4] 28.9 [8.5] 4.7	38.0 [11.1] 26.9 [7.9] 4.7	37.0 [10.8] 36.1 [10.6] 4.7	36.3 [10.6] 34.6 [10.1] 4.7	35.3 [10.4] 32.2 [9.4] 4.6
	125 [51.7]	Total BTUH [kW] Sens BTUH [kW] Power	41.5 [12.2] 23.0 [6.7] 5.1	40.8 [12.0] 22.0 [6.4] 5.1	39.7 [11.6] 20.5 [6.0] 5.0	38.1 [11.2] 29.1 [8.5] 5.1	37.4 [11.0] 27.8 [8.2] 5.0	36.4 [10.7] 25.9 [7.6] 5.0	35.3 [10.3] 35.0 [10.2] 5.1	34.6 [10.2] 33.4 [9.8] 5.0	33.7 [9.9] 31.1 [9.1] 5.0

DR —Depression ratio
dbE —Entering air dry bulb
wbE—Entering air wet bulb

Total —Total capacity x 1000 BTUH
Sens —Sensible capacity x 1000 BTUH
Power —KW input

NOTES: ① When the entering air dry bulb is other than 80°F [27°C], adjust the sensible capacity from the table by adding $[1.10 \times \text{CFM} \times (1 - \text{DR}) \times (\text{dbE} - 80)]$.

[] Designates Metric Conversions



GROSS SYSTEMS PERFORMANCE DATA—RACA14060A

ENTERING INDOOR AIR @ 80°F [26.7°C] dbE ①											
wbE		71°F [21.7°C]			67°F [19.4°C]			63°F [17.2°C]			
CFM [L/s]		1870 [883]	1700 [802]	1440 [680]	1870 [883]	1700 [802]	1440 [680]	1870 [883]	1700 [802]	1440 [680]	
DR ①		0.14	0.13	0.11	0.14	0.13	0.11	0.14	0.13	0.11	
OUTDOOR DRY BULB TEMPERATURE °F [°C]	75 [23.9]	Total BTUH [kW] Sens BTUH [kW] Power	72.1 [21.1] 40.6 [11.9] 3.5	70.8 [20.7] 38.8 [11.4] 3.5	68.8 [20.2] 36.0 [10.6] 3.5	67.8 [19.9] 47.8 [14.0] 3.5	66.6 [19.5] 45.7 [13.4] 3.5	64.7 [19.0] 42.4 [12.4] 3.4	63.6 [18.6] 54.4 [16.0] 3.5	62.4 [18.3] 52.0 [15.2] 3.5	60.7 [17.8] 48.3 [14.2] 3.4
	80 [26.7]	Total BTUH [kW] Sens BTUH [kW] Power	70.3 [20.6] 39.6 [11.6] 3.7	69.0 [20.2] 37.8 [11.1] 3.7	67.1 [19.7] 35.1 [10.3] 3.7	66.0 [19.3] 46.7 [13.7] 3.7	64.8 [19.0] 44.7 [13.1] 3.7	63.0 [18.5] 41.5 [12.2] 3.6	61.8 [18.1] 53.4 [15.6] 3.7	60.7 [17.8] 51.0 [15.0] 3.6	59.0 [17.3] 47.4 [13.9] 3.6
	85 [29.4]	Total BTUH [kW] Sens BTUH [kW] Power	68.4 [20.0] 38.5 [11.3] 4.0	67.1 [19.7] 36.8 [10.8] 3.9	65.3 [19.1] 34.1 [10.0] 3.9	64.1 [18.8] 45.7 [13.4] 3.9	62.9 [18.4] 43.6 [12.8] 3.9	61.2 [17.9] 40.5 [11.9] 3.8	59.9 [17.5] 52.3 [15.3] 3.9	58.8 [17.2] 50.0 [14.6] 3.9	57.2 [16.7] 46.4 [13.6] 3.8
	90 [32.2]	Total BTUH [kW] Sens BTUH [kW] Power	66.4 [19.5] 37.3 [10.9] 4.2	65.2 [19.1] 35.7 [10.5] 4.1	63.4 [18.6] 33.1 [9.7] 4.1	62.1 [18.2] 44.5 [13.1] 4.2	61.0 [17.9] 42.6 [12.5] 4.1	59.3 [17.4] 39.5 [11.6] 4.1	57.9 [17.0] 51.2 [15.0] 4.1	56.8 [16.7] 48.9 [14.3] 4.1	55.3 [16.2] 45.4 [13.3] 4.0
	95 [35]	Total BTUH [kW] Sens BTUH [kW] Power	64.3 [18.8] 36.2 [10.6] 4.4	63.2 [18.5] 34.6 [10.1] 4.4	61.4 [18.0] 32.1 [9.4] 4.3	60.0 [17.6] 43.4 [12.7] 4.4	58.9 [17.3] 41.4 [12.1] 4.4	57.3 [16.8] 38.5 [11.3] 4.3	55.8 [16.4] 50.0 [14.7] 4.4	54.8 [16.1] 47.8 [14.0] 4.3	53.3 [15.6] 44.4 [13.0] 4.3
	100 [37.8]	Total BTUH [kW] Sens BTUH [kW] Power	62.1 [18.2] 35.0 [10.3] 4.7	61.0 [17.9] 33.4 [9.8] 4.7	59.3 [17.4] 31.0 [9.1] 4.6	57.9 [17.0] 42.2 [12.4] 4.7	56.8 [16.7] 40.3 [11.8] 4.6	55.2 [16.2] 37.4 [11.0] 4.6	53.6 [15.7] 48.8 [14.3] 4.7	52.7 [15.4] 46.7 [13.7] 4.6	51.2 [15.0] 43.3 [12.7] 4.5
	105 [40.6]	Total BTUH [kW] Sens BTUH [kW] Power	59.9 [17.5] 33.8 [9.9] 5.0	58.8 [17.2] 32.3 [9.5] 5.0	57.2 [16.8] 30.0 [8.8] 4.9	55.6 [16.3] 41.0 [12.0] 5.0	54.6 [16.0] 39.1 [11.5] 4.9	53.1 [15.6] 36.3 [10.6] 4.9	51.4 [15.1] 47.6 [14.0] 4.9	50.5 [14.8] 45.5 [13.3] 4.9	49.1 [14.4] 42.2 [12.4] 4.8
	110 [43.3]	Total BTUH [kW] Sens BTUH [kW] Power	57.6 [16.9] 32.5 [9.5] 5.3	56.5 [16.6] 31.0 [9.1] 5.3	55.0 [16.1] 28.8 [8.4] 5.2	53.3 [15.6] 39.7 [11.6] 5.3	52.3 [15.3] 37.9 [11.1] 5.2	50.9 [14.9] 35.2 [10.3] 5.2	49.0 [14.4] 46.3 [13.6] 5.2	48.2 [14.1] 44.3 [13.0] 5.2	46.8 [13.7] 41.1 [12.0] 5.1
	115 [46.1]	Total BTUH [kW] Sens BTUH [kW] Power	55.1 [16.2] 31.2 [9.1] 5.6	54.1 [15.9] 29.8 [8.7] 5.6	52.6 [15.4] 27.7 [8.1] 5.5	50.8 [14.9] 38.4 [11.2] 5.6	49.9 [14.6] 36.7 [10.7] 5.5	48.5 [14.2] 34.0 [10.0] 5.5	46.6 [13.7] 45.0 [13.2] 5.6	45.8 [13.4] 43.0 [12.6] 5.5	44.5 [13.0] 40.0 [11.7] 5.4
	120 [48.9]	Total BTUH [kW] Sens BTUH [kW] Power	52.6 [15.4] 29.8 [8.7] 6.0	51.7 [15.1] 28.5 [8.4] 5.9	50.2 [14.7] 26.5 [7.8] 5.8	48.3 [14.2] 37.0 [10.8] 5.9	47.5 [13.9] 35.4 [10.4] 5.9	46.1 [13.5] 32.8 [9.6] 5.8	44.1 [12.9] 43.7 [12.8] 5.9	43.3 [12.7] 41.7 [12.2] 5.9	42.1 [12.3] 38.8 [11.4] 5.8
	125 [51.7]	Total BTUH [kW] Sens BTUH [kW] Power	50.0 [14.7] 28.5 [8.3] 6.3	49.1 [14.4] 27.2 [8.0] 6.3	47.8 [14.0] 25.2 [7.4] 6.2	45.7 [13.4] 35.6 [10.4] 6.3	44.9 [13.2] 34.1 [10.0] 6.2	43.7 [12.8] 31.6 [9.3] 6.2	41.5 [12.2] 41.5 [12.2] 6.3	40.8 [11.9] 40.4 [11.8] 6.2	39.6 [11.6] 37.5 [11.0] 6.1

DR —Depression ratio
dbE —Entering air dry bulb
wbE—Entering air wet bulb

Total —Total capacity x 1000 BTUH
Sens —Sensible capacity x 1000 BTUH
Power —KW input

NOTES: ① When the entering air dry bulb is other than 80°F [27°C], adjust the sensible capacity from the table by adding [1.10 x CFM x (1 – DR) x (dbE – 80)].

[] Designates Metric Conversions





GROSS SYSTEMS PERFORMANCE DATA – RACA15024A

ENTERING INDOOR AIR @ 80°F [26.7°C] dbE ①											
wbE		71°F [21.7°C]			67°F [19.4°C]			63°F [17.2°C]			
CFM [L/s]		990 [467]	900 [425]	760 [359]	990 [467]	900 [425]	760 [359]	990 [467]	900 [425]	760 [359]	
DR ①		0.21	0.19	0.15	0.21	0.19	0.15	0.21	0.19	0.15	
OUTDOOR DRY BULB TEMPERATURE °F [°C]	75 [23.9]	Total BTUH [kW] Sens BTUH [kW] Power	30.9 [9.1] 18.7 [5.5] 1.4	30.4 [8.9] 17.9 [5.2] 1.4	29.5 [8.7] 16.6 [4.9] 1.4	29.1 [8.5] 21.9 [6.4] 1.4	28.6 [8.4] 20.9 [6.1] 1.4	27.8 [8.1] 19.4 [5.7] 1.4	27.5 [8.1] 24.6 [7.2] 1.4	27.0 [7.9] 23.5 [6.9] 1.4	26.2 [7.7] 21.8 [6.4] 1.4
	80 [26.7]	Total BTUH [kW] Sens BTUH [kW] Power	30.0 [8.8] 18.2 [5.3] 1.5	29.4 [8.6] 17.4 [5.1] 1.5	28.6 [8.4] 16.1 [4.7] 1.5	28.1 [8.2] 21.4 [6.3] 1.5	27.6 [8.1] 20.4 [6.0] 1.5	26.8 [7.9] 18.9 [5.5] 1.5	26.5 [7.8] 24.0 [7.0] 1.5	26.0 [7.6] 23.0 [6.7] 1.5	25.3 [7.4] 21.3 [6.2] 1.5
	85 [29.4]	Total BTUH [kW] Sens BTUH [kW] Power	29.0 [8.5] 17.6 [5.2] 1.6	28.5 [8.3] 16.8 [4.9] 1.6	27.7 [8.1] 15.6 [4.6] 1.6	27.1 [8.0] 20.8 [6.1] 1.6	26.7 [7.8] 19.9 [5.8] 1.6	25.9 [7.6] 18.4 [5.4] 1.6	25.5 [7.5] 23.5 [6.9] 1.6	25.1 [7.3] 22.4 [6.6] 1.6	24.4 [7.1] 20.8 [6.1] 1.6
	90 [32.2]	Total BTUH [kW] Sens BTUH [kW] Power	28.0 [8.2] 17.0 [5.0] 1.7	27.5 [8.1] 16.3 [4.8] 1.7	26.7 [7.8] 15.1 [4.4] 1.7	26.1 [7.7] 20.2 [5.9] 1.7	25.7 [7.5] 19.3 [5.7] 1.7	25.0 [7.3] 17.9 [5.3] 1.7	24.5 [7.2] 22.9 [6.7] 1.7	24.1 [7.1] 21.9 [6.4] 1.7	23.4 [6.9] 20.3 [5.9] 1.7
	95 [35]	Total BTUH [kW] Sens BTUH [kW] Power	27.0 [7.9] 16.5 [4.8] 1.9	26.5 [7.8] 15.7 [4.6] 1.8	25.7 [7.5] 14.6 [4.3] 1.8	25.1 [7.4] 19.7 [5.8] 1.8	24.7 [7.2] 18.8 [5.5] 1.8	24.0 [7.0] 17.4 [5.1] 1.8	23.5 [6.9] 22.3 [6.5] 1.8	23.1 [6.8] 21.3 [6.2] 1.8	22.4 [6.6] 19.8 [5.8] 1.8
	100 [37.8]	Total BTUH [kW] Sens BTUH [kW] Power	25.9 [7.6] 15.9 [4.6] 2.0	25.5 [7.5] 15.2 [4.4] 2.0	24.8 [7.3] 14.1 [4.1] 1.9	24.1 [7.1] 19.1 [5.6] 2.0	23.7 [6.9] 18.2 [5.3] 2.0	23.0 [6.7] 16.9 [5.0] 1.9	22.5 [6.6] 21.7 [6.4] 2.0	22.1 [6.5] 20.8 [6.1] 1.9	21.5 [6.3] 19.2 [5.6] 1.9
	105 [40.6]	Total BTUH [kW] Sens BTUH [kW] Power	24.9 [7.3] 15.3 [4.5] 2.1	24.5 [7.2] 14.6 [4.3] 2.1	23.8 [7.0] 13.5 [4.0] 2.1	23.1 [6.8] 18.5 [5.4] 2.1	22.6 [6.6] 17.7 [5.2] 2.1	22.0 [6.4] 16.4 [4.8] 2.1	21.4 [6.3] 21.1 [6.2] 2.1	21.1 [6.2] 20.2 [5.9] 2.1	20.5 [6.0] 18.7 [5.5] 2.0
	110 [43.3]	Total BTUH [kW] Sens BTUH [kW] Power	23.8 [7.0] 14.7 [4.3] 2.3	23.4 [6.9] 14.0 [4.1] 2.2	22.7 [6.7] 13.0 [3.8] 2.2	22.0 [6.4] 17.9 [5.2] 2.2	21.6 [6.3] 17.1 [5.0] 2.2	21.0 [6.1] 15.8 [4.6] 2.2	20.4 [6.0] 20.4 [6.0] 2.2	20.0 [5.9] 19.6 [5.7] 2.2	19.4 [5.7] 18.2 [5.3] 2.2
	115 [46.1]	Total BTUH [kW] Sens BTUH [kW] Power	22.8 [6.7] 14.1 [4.1] 2.4	22.3 [6.5] 13.4 [3.9] 2.4	21.7 [6.4] 12.5 [3.6] 2.3	20.9 [6.1] 17.3 [5.1] 2.4	20.5 [6.0] 16.5 [4.8] 2.4	19.9 [5.8] 15.3 [4.5] 2.3	19.3 [5.7] 19.3 [5.7] 2.4	18.9 [5.6] 18.9 [5.6] 2.4	18.4 [5.4] 17.6 [5.2] 2.3
	120 [48.9]	Total BTUH [kW] Sens BTUH [kW] Power	21.7 [6.3] 13.4 [3.9] 2.6	21.3 [6.2] 12.8 [3.8] 2.5	20.7 [6.1] 11.9 [3.5] 2.5	19.8 [5.8] 16.6 [4.9] 2.5	19.5 [5.7] 15.9 [4.7] 2.5	18.9 [5.5] 14.7 [4.3] 2.5	18.2 [5.3] 18.2 [5.3] 2.5	17.9 [5.2] 17.9 [5.2] 2.5	17.4 [5.1] 17.1 [5.0] 2.5
125 [51.7]	Total BTUH [kW] Sens BTUH [kW] Power	20.5 [6.0] 12.8 [3.8] 2.7	20.2 [5.9] 12.2 [3.6] 2.7	19.6 [5.7] 11.3 [3.3] 2.7	18.7 [5.5] 16.0 [4.7] 2.7	18.4 [5.4] 15.3 [4.5] 2.7	17.8 [5.2] 14.2 [4.2] 2.7	17.1 [5.0] 17.1 [5.0] 2.7	16.8 [4.9] 16.8 [4.9] 2.7	16.3 [4.8] 16.3 [4.8] 2.6	

DR —Depression ratio
dbE —Entering air dry bulb
wbE—Entering air wet bulb

Total —Total capacity x 1000 BTUH
Sens —Sensible capacity x 1000 BTUH
Power —KW input

NOTES: ① When the entering air dry bulb is other than 80°F [27°C], adjust the sensible capacity from the table by adding [1.10 x CFM x (1 – DR) x (dbE – 80)].

[] Designates Metric Conversions





GROSS SYSTEMS PERFORMANCE DATA—RACA15030A

ENTERING INDOOR AIR @ 80°F [26.7°C] dbE ①											
wbE		71°F [21.7°C]			67°F [19.4°C]			63°F [17.2°C]			
CFM [L/s]		1070 [505]	975 [460]	830 [392]	1070 [505]	975 [460]	830 [392]	1070 [505]	975 [460]	830 [392]	
DR ①		0.16	0.14	0.1	0.16	0.14	0.1	0.16	0.14	0.1	
OUTDOOR DRY BULB TEMPERATURE °F [°C]	75 [23.9]	Total BTUH [kW] Sens BTUH [kW] Power	36.8 [10.8] 21.5 [6.3] 1.7	36.1 [10.6] 20.5 [6.0] 1.7	35.2 [10.3] 19.1 [5.6] 1.6	34.3 [10.1] 25.1 [7.4] 1.7	33.7 [9.9] 24.0 [7.0] 1.6	32.8 [9.6] 22.4 [6.6] 1.6	32.4 [9.5] 28.3 [8.3] 1.6	31.8 [9.3] 27.1 [7.9] 1.6	31.0 [9.1] 25.2 [7.4] 1.6
	80 [26.7]	Total BTUH [kW] Sens BTUH [kW] Power	35.7 [10.5] 21.0 [6.1] 1.8	35.1 [10.3] 20.1 [5.9] 1.7	34.2 [10.0] 18.7 [5.5] 1.7	33.3 [9.7] 24.7 [7.2] 1.7	32.7 [9.6] 23.6 [6.9] 1.7	31.8 [9.3] 21.9 [6.4] 1.7	31.3 [9.2] 27.8 [8.2] 1.7	30.8 [9.0] 26.6 [7.8] 1.7	30.0 [8.8] 24.8 [7.3] 1.7
	85 [29.4]	Total BTUH [kW] Sens BTUH [kW] Power	34.7 [10.2] 20.5 [6.0] 1.9	34.1 [10.0] 19.6 [5.7] 1.8	33.2 [9.7] 18.2 [5.3] 1.8	32.2 [9.4] 24.2 [7.1] 1.8	31.7 [9.3] 23.1 [6.8] 1.8	30.8 [9.0] 21.5 [6.3] 1.8	30.3 [8.9] 27.4 [8.0] 1.8	29.8 [8.7] 26.2 [7.7] 1.8	29.0 [8.5] 24.3 [7.1] 1.8
	90 [32.2]	Total BTUH [kW] Sens BTUH [kW] Power	33.7 [9.9] 20.0 [5.9] 2.0	33.1 [9.7] 19.1 [5.6] 1.9	32.2 [9.4] 17.8 [5.2] 1.9	31.2 [9.1] 23.6 [6.9] 1.9	30.6 [9.0] 22.6 [6.6] 1.9	29.8 [8.7] 21.0 [6.2] 1.9	29.2 [8.6] 26.8 [7.9] 1.9	28.7 [8.4] 25.7 [7.5] 1.9	28.0 [8.2] 23.9 [7.0] 1.9
	95 [35]	Total BTUH [kW] Sens BTUH [kW] Power	32.6 [9.5] 19.4 [5.7] 2.1	32.0 [9.4] 18.6 [5.4] 2.1	31.2 [9.1] 17.3 [5.1] 2.0	30.1 [8.8] 23.1 [6.8] 2.1	29.6 [8.7] 22.1 [6.5] 2.0	28.8 [8.4] 20.5 [6.0] 2.0	28.2 [8.3] 26.3 [7.7] 2.0	27.7 [8.1] 25.1 [7.4] 2.0	26.9 [7.9] 23.4 [6.9] 2.0
	100 [37.8]	Total BTUH [kW] Sens BTUH [kW] Power	31.5 [9.2] 18.8 [5.5] 2.2	31.0 [9.1] 18.0 [5.3] 2.2	30.1 [8.8] 16.8 [4.9] 2.1	29.0 [8.5] 22.5 [6.6] 2.2	28.5 [8.4] 21.5 [6.3] 2.2	27.7 [8.1] 20.0 [5.9] 2.1	27.1 [7.9] 25.7 [7.5] 2.2	26.6 [7.8] 24.6 [7.2] 2.1	25.9 [7.6] 22.9 [6.7] 2.1
	105 [40.6]	Total BTUH [kW] Sens BTUH [kW] Power	30.4 [8.9] 18.2 [5.3] 2.3	29.9 [8.8] 17.4 [5.1] 2.3	29.1 [8.5] 16.2 [4.8] 2.3	27.9 [8.2] 21.9 [6.4] 2.3	27.4 [8.0] 20.9 [6.1] 2.3	26.7 [7.8] 19.5 [5.7] 2.3	26.0 [7.6] 25.1 [7.4] 2.3	25.6 [7.5] 24.0 [7.0] 2.3	24.9 [7.3] 22.3 [6.5] 2.2
	110 [43.3]	Total BTUH [kW] Sens BTUH [kW] Power	29.3 [8.6] 17.6 [5.2] 2.5	28.8 [8.4] 16.8 [4.9] 2.4	28.0 [8.2] 15.7 [4.6] 2.4	26.8 [7.9] 21.3 [6.2] 2.4	26.4 [7.7] 20.3 [6.0] 2.4	25.6 [7.5] 18.9 [5.5] 2.4	24.9 [7.3] 24.4 [7.2] 2.4	24.5 [7.2] 23.4 [6.9] 2.4	23.8 [7.0] 21.8 [6.4] 2.4
	115 [46.1]	Total BTUH [kW] Sens BTUH [kW] Power	28.2 [8.3] 16.9 [5.0] 2.6	27.7 [8.1] 16.2 [4.7] 2.6	27.0 [7.9] 15.1 [4.4] 2.5	25.7 [7.5] 20.6 [6.0] 2.6	25.3 [7.4] 19.7 [5.8] 2.6	24.6 [7.2] 18.3 [5.4] 2.5	23.8 [7.0] 23.8 [7.0] 2.6	23.4 [6.8] 22.7 [6.7] 2.6	22.7 [6.7] 21.2 [6.2] 2.5
	120 [48.9]	Total BTUH [kW] Sens BTUH [kW] Power	27.1 [7.9] 16.2 [4.8] 2.8	26.6 [7.8] 15.5 [4.5] 2.7	25.9 [7.6] 14.4 [4.2] 2.7	24.6 [7.2] 19.9 [5.8] 2.7	24.2 [7.1] 19.0 [5.6] 2.7	23.5 [6.9] 17.7 [5.2] 2.7	22.7 [6.6] 22.7 [6.6] 2.7	22.3 [6.5] 22.1 [6.5] 2.7	21.7 [6.3] 20.5 [6.0] 2.7
	125 [51.7]	Total BTUH [kW] Sens BTUH [kW] Power	25.9 [7.6] 15.5 [4.5] 2.9	25.5 [7.5] 14.8 [4.3] 2.9	24.8 [7.3] 13.8 [4.0] 2.8	23.4 [6.9] 19.2 [5.6] 2.9	23.0 [6.7] 18.3 [5.4] 2.9	22.4 [6.6] 17.1 [5.0] 2.8	21.5 [6.3] 21.5 [6.3] 2.9	21.1 [6.2] 21.1 [6.2] 2.9	20.6 [6.0] 19.9 [5.8] 2.8

DR —Depression ratio
dbE —Entering air dry bulb
wbE—Entering air wet bulb

Total —Total capacity x 1000 BTUH
Sens —Sensible capacity x 1000 BTUH
Power —kW input

NOTES: ① When the entering air dry bulb is other than 80°F [27°C], adjust the sensible capacity from the table by adding [1.10 x CFM x (1 - DR) x (dbE - 80)].

[] Designates Metric Conversions





GROSS SYSTEMS PERFORMANCE DATA – RACA15036A

ENTERING INDOOR AIR @ 80°F [26.7°C] dbE ①											
wbE		71°F [21.7°C]			67°F [19.4°C]			63°F [17.2°C]			
CFM [L/s]		1320 [623]	1200 [566]	1020 [481]	1320 [623]	1200 [566]	1020 [481]	1320 [623]	1200 [566]	1020 [481]	
DR ①		0.19	0.18	0.15	0.19	0.18	0.15	0.19	0.18	0.15	
OUTDOOR DRY BULB TEMPERATURE °F [°C]	75 [23.9]	Total BTUH [kW] Sens BTUH [kW] Power	44.8 [13.1] 26.2 [7.7] 2.0	44.0 [12.9] 25.0 [7.3] 2.0	42.8 [12.5] 23.3 [6.8] 2.0	41.9 [12.3] 30.6 [9.0] 2.0	41.1 [12.1] 29.2 [8.6] 2.0	40.0 [11.7] 27.2 [8.0] 2.0	38.9 [11.4] 33.9 [9.9] 2.0	38.2 [11.2] 32.4 [9.5] 2.0	37.2 [10.9] 30.1 [8.8] 2.0
	80 [26.7]	Total BTUH [kW] Sens BTUH [kW] Power	43.5 [12.8] 25.4 [7.5] 2.1	42.7 [12.5] 24.3 [7.1] 2.1	41.6 [12.2] 22.6 [6.6] 2.1	40.6 [11.9] 29.9 [8.7] 2.1	39.9 [11.7] 28.5 [8.4] 2.1	38.8 [11.4] 26.5 [7.8] 2.1	37.6 [11.0] 33.2 [9.7] 2.1	36.9 [10.8] 31.7 [9.3] 2.1	35.9 [10.5] 29.5 [8.6] 2.1
	85 [29.4]	Total BTUH [kW] Sens BTUH [kW] Power	42.2 [12.4] 24.7 [7.2] 2.3	41.4 [12.1] 23.6 [6.9] 2.2	40.3 [11.8] 21.9 [6.4] 2.2	39.3 [11.5] 29.1 [8.5] 2.2	38.6 [11.3] 27.8 [8.1] 2.2	37.5 [11.0] 25.9 [7.6] 2.2	36.3 [10.6] 32.4 [9.5] 2.2	35.6 [10.4] 31.0 [9.1] 2.2	34.6 [10.2] 28.8 [8.4] 2.2
	90 [32.2]	Total BTUH [kW] Sens BTUH [kW] Power	40.9 [12.0] 23.9 [7.0] 2.4	40.1 [11.8] 22.9 [6.7] 2.4	39.0 [11.4] 21.3 [6.2] 2.3	37.9 [11.1] 28.3 [8.3] 2.4	37.2 [10.9] 27.1 [7.9] 2.4	36.2 [10.6] 25.2 [7.4] 2.3	34.9 [10.2] 31.6 [9.3] 2.4	34.3 [10.1] 30.2 [8.9] 2.3	33.4 [9.8] 28.1 [8.2] 2.3
	95 [35]	Total BTUH [kW] Sens BTUH [kW] Power	39.5 [11.6] 23.1 [6.8] 2.5	38.8 [11.4] 22.1 [6.5] 2.5	37.7 [11.1] 20.6 [6.0] 2.5	36.6 [10.7] 27.5 [8.1] 2.5	35.9 [10.5] 26.3 [7.7] 2.5	34.9 [10.2] 24.5 [7.2] 2.5	33.6 [9.8] 30.9 [9.0] 2.5	33.0 [9.7] 29.5 [8.6] 2.5	32.1 [9.4] 27.4 [8.0] 2.5
	100 [37.8]	Total BTUH [kW] Sens BTUH [kW] Power	38.1 [11.2] 22.3 [6.5] 2.7	37.5 [11.0] 21.3 [6.3] 2.7	36.4 [10.7] 19.9 [5.8] 2.6	35.2 [10.3] 26.7 [7.8] 2.7	34.6 [10.1] 25.6 [7.5] 2.7	33.6 [9.9] 23.8 [7.0] 2.6	32.2 [9.4] 30.1 [8.8] 2.7	31.6 [9.3] 28.7 [8.4] 2.6	30.8 [9.0] 26.7 [7.8] 2.6
	105 [40.6]	Total BTUH [kW] Sens BTUH [kW] Power	36.8 [10.8] 21.5 [6.3] 2.9	36.1 [10.6] 20.6 [6.0] 2.8	35.1 [10.3] 19.1 [5.6] 2.8	33.8 [9.9] 25.9 [7.6] 2.8	33.2 [9.7] 24.8 [7.3] 2.8	32.3 [9.5] 23.0 [6.7] 2.8	30.8 [9.0] 29.2 [8.6] 2.8	30.3 [8.9] 27.9 [8.2] 2.8	29.5 [8.6] 26.0 [7.6] 2.8
	110 [43.3]	Total BTUH [kW] Sens BTUH [kW] Power	35.4 [10.4] 20.7 [6.1] 3.0	34.7 [10.2] 19.8 [5.8] 3.0	33.8 [9.9] 18.4 [5.4] 3.0	32.4 [9.5] 25.1 [7.4] 3.0	31.9 [9.3] 24.0 [7.0] 3.0	31.0 [9.1] 22.3 [6.5] 3.0	29.4 [8.6] 28.4 [8.3] 3.0	28.9 [8.5] 27.1 [8.0] 3.0	28.1 [8.2] 25.2 [7.4] 2.9
	115 [46.1]	Total BTUH [kW] Sens BTUH [kW] Power	34.0 [10.0] 19.8 [5.8] 3.2	33.4 [9.8] 18.9 [5.5] 3.2	32.4 [9.5] 17.6 [5.2] 3.2	31.0 [9.1] 24.2 [7.1] 3.2	30.5 [8.9] 23.1 [6.8] 3.2	29.6 [8.7] 21.5 [6.3] 3.1	28.0 [8.2] 27.5 [8.1] 3.2	27.5 [8.1] 26.3 [7.7] 3.2	26.8 [7.8] 24.5 [7.2] 3.1
	120 [48.9]	Total BTUH [kW] Sens BTUH [kW] Power	32.5 [9.5] 18.9 [5.6] 3.4	32.0 [9.4] 18.1 [5.3] 3.4	31.1 [9.1] 16.8 [4.9] 3.4	29.6 [8.7] 23.3 [6.8] 3.4	29.1 [8.5] 22.3 [6.5] 3.4	28.3 [8.3] 20.7 [6.1] 3.3	26.6 [7.8] 26.6 [7.8] 3.4	26.1 [7.7] 25.5 [7.5] 3.4	25.4 [7.4] 23.7 [6.9] 3.3
	125 [51.7]	Total BTUH [kW] Sens BTUH [kW] Power	31.1 [9.1] 18.0 [5.3] 3.6	30.5 [9.0] 17.2 [5.1] 3.6	29.7 [8.7] 16.0 [4.7] 3.6	28.2 [8.3] 22.4 [6.6] 3.6	27.7 [8.1] 21.4 [6.3] 3.6	26.9 [7.9] 19.9 [5.8] 3.6	25.2 [7.4] 25.2 [7.4] 3.6	24.7 [7.2] 24.6 [7.2] 3.6	24.1 [7.0] 22.9 [6.7] 3.5

DR —Depression ratio
dbE —Entering air dry bulb
wbE—Entering air wet bulb

Total —Total capacity x 1000 BTUH
Sens —Sensible capacity x 1000 BTUH
Power —KW input

NOTES: ① When the entering air dry bulb is other than 80°F [27°C], adjust the sensible capacity from the table by adding $[1.10 \times \text{CFM} \times (1 - \text{DR}) \times (\text{dbE} - 80)]$.

[] Designates Metric Conversions





GROSS SYSTEMS PERFORMANCE DATA—RACA15042A

		ENTERING INDOOR AIR @ 80°F [26.7°C] dbE ①									
wbE		71°F [21.7°C]			67°F [19.4°C]			63°F [17.2°C]			
CFM [L/s]		1430 [675]	1300 [614]	1100 [519]	1430 [675]	1300 [614]	1100 [519]	1430 [675]	1300 [614]	1100 [519]	
DR ①		0.17	0.16	0.13	0.17	0.16	0.13	0.17	0.16	0.13	
OUTDOOR DRY BULB TEMPERATURE °F [°C]	75 [23.9]	Total BTUH [kW] Sens BTUH [kW] Power	50.1 [14.7] 28.6 [8.4] 2.4	49.2 [14.4] 27.3 [8.0] 2.3	47.8 [14.0] 25.3 [7.4] 2.3	47.2 [13.8] 33.9 [9.9] 2.4	46.4 [13.6] 32.4 [9.5] 2.3	45.1 [13.2] 30.0 [8.8] 2.3	44.7 [13.1] 38.8 [11.4] 2.3	43.9 [12.9] 37.1 [10.9] 2.3	42.7 [12.5] 34.4 [10.1] 2.3
	80 [26.7]	Total BTUH [kW] Sens BTUH [kW] Power	48.8 [14.3] 27.9 [8.2] 2.5	47.9 [14.0] 26.7 [7.8] 2.5	46.6 [13.6] 24.8 [7.3] 2.5	45.9 [13.5] 33.2 [9.7] 2.5	45.1 [13.2] 31.8 [9.3] 2.5	43.8 [12.8] 29.5 [8.6] 2.4	43.4 [12.7] 38.1 [11.2] 2.5	42.6 [12.5] 36.4 [10.7] 2.5	41.5 [12.1] 33.8 [9.9] 2.4
	85 [29.4]	Total BTUH [kW] Sens BTUH [kW] Power	47.4 [13.9] 27.2 [8.0] 2.7	46.6 [13.7] 26.0 [7.6] 2.6	45.3 [13.3] 24.2 [7.1] 2.6	44.6 [13.1] 32.6 [9.5] 2.6	43.8 [12.8] 31.1 [9.1] 2.6	42.6 [12.5] 28.9 [8.5] 2.6	42.1 [12.3] 37.5 [11.0] 2.6	41.3 [12.1] 35.8 [10.5] 2.6	40.2 [11.8] 33.2 [9.7] 2.6
	90 [32.2]	Total BTUH [kW] Sens BTUH [kW] Power	46.1 [13.5] 26.5 [7.8] 2.8	45.3 [13.3] 25.3 [7.4] 2.8	44.0 [12.9] 23.5 [6.9] 2.8	43.2 [12.7] 31.8 [9.3] 2.8	42.5 [12.4] 30.4 [8.9] 2.8	41.3 [12.1] 28.2 [8.3] 2.7	40.7 [11.9] 36.8 [10.8] 2.8	40.0 [11.7] 35.1 [10.3] 2.8	38.9 [11.4] 32.6 [9.6] 2.7
	95 [35]	Total BTUH [kW] Sens BTUH [kW] Power	44.7 [13.1] 25.8 [7.6] 3.0	43.9 [12.9] 24.6 [7.2] 3.0	42.7 [12.5] 22.9 [6.7] 2.9	41.8 [12.3] 31.1 [9.1] 3.0	41.1 [12.0] 29.7 [8.7] 3.0	39.9 [11.7] 27.6 [8.1] 2.9	39.3 [11.5] 36.0 [10.5] 3.0	38.6 [11.3] 34.4 [10.1] 2.9	37.5 [11.0] 31.9 [9.4] 2.9
	100 [37.8]	Total BTUH [kW] Sens BTUH [kW] Power	43.3 [12.7] 25.0 [7.3] 3.2	42.5 [12.4] 23.9 [7.0] 3.2	41.3 [12.1] 22.1 [6.5] 3.1	40.4 [11.8] 30.3 [8.9] 3.2	39.7 [11.6] 28.9 [8.5] 3.1	38.6 [11.3] 26.9 [7.9] 3.1	37.9 [11.1] 35.2 [10.3] 3.2	37.2 [10.9] 33.6 [9.9] 3.1	36.2 [10.6] 31.2 [9.1] 3.1
	105 [40.6]	Total BTUH [kW] Sens BTUH [kW] Power	41.8 [12.2] 24.1 [7.1] 3.4	41.0 [12.0] 23.1 [6.8] 3.4	39.9 [11.7] 21.4 [6.3] 3.3	38.9 [11.4] 29.4 [8.6] 3.4	38.2 [11.2] 28.1 [8.2] 3.3	37.2 [10.9] 26.1 [7.7] 3.3	36.4 [10.7] 34.4 [10.1] 3.4	35.8 [10.5] 32.8 [9.6] 3.3	34.8 [10.2] 30.5 [8.9] 3.3
	110 [43.3]	Total BTUH [kW] Sens BTUH [kW] Power	40.3 [11.8] 23.3 [6.8] 3.6	39.6 [11.6] 22.2 [6.5] 3.6	38.5 [11.3] 20.6 [6.0] 3.5	37.4 [11.0] 28.6 [8.4] 3.6	36.8 [10.8] 27.3 [8.0] 3.5	35.7 [10.5] 25.3 [7.4] 3.5	34.9 [10.2] 33.5 [9.8] 3.6	34.3 [10.1] 32.0 [9.4] 3.5	33.3 [9.8] 29.7 [8.7] 3.5
	115 [46.1]	Total BTUH [kW] Sens BTUH [kW] Power	38.7 [11.4] 22.3 [6.5] 3.8	38.0 [11.1] 21.4 [6.3] 3.8	37.0 [10.8] 19.8 [5.8] 3.7	35.9 [10.5] 27.7 [8.1] 3.8	35.3 [10.3] 26.4 [7.7] 3.8	34.3 [10.0] 24.5 [7.2] 3.7	33.4 [9.8] 32.6 [9.5] 3.8	32.8 [9.6] 31.1 [9.1] 3.7	31.9 [9.3] 28.9 [8.5] 3.7
	120 [48.9]	Total BTUH [kW] Sens BTUH [kW] Power	37.2 [10.9] 21.4 [6.3] 4.0	36.5 [10.7] 20.4 [6.0] 4.0	35.5 [10.4] 19.0 [5.6] 3.9	34.3 [10.1] 26.7 [7.8] 4.0	33.7 [9.9] 25.5 [7.5] 4.0	32.8 [9.6] 23.7 [6.9] 3.9	31.8 [9.3] 31.6 [9.3] 4.0	31.2 [9.2] 30.2 [8.9] 4.0	30.4 [8.9] 28.0 [8.2] 3.9
	125 [51.7]	Total BTUH [kW] Sens BTUH [kW] Power	35.6 [10.4] 20.4 [6.0] 4.3	34.9 [10.2] 19.5 [5.7] 4.2	33.9 [9.9] 18.1 [5.3] 4.2	32.7 [9.6] 25.7 [7.5] 4.3	32.1 [9.4] 24.6 [7.2] 4.2	31.2 [9.2] 22.8 [6.7] 4.2	30.2 [8.8] 30.2 [8.8] 4.2	29.7 [8.7] 29.3 [8.6] 4.2	28.8 [8.4] 27.2 [8.0] 4.1

DR —Depression ratio
dbE —Entering air dry bulb
wbE—Entering air wet bulb

Total —Total capacity x 1000 BTUH
Sens —Sensible capacity x 1000 BTUH
Power —kW input

NOTES: ① When the entering air dry bulb is other than 80°F [27°C], adjust the sensible capacity from the table by adding [1.10 x CFM x (1 - DR) x (dbE - 80)].

[] Designates Metric Conversions





GROSS SYSTEMS PERFORMANCE DATA – RACA15048A

ENTERING INDOOR AIR @ 80°F [26.7°C] dbE ①											
wbE		71°F [21.7°C]			67°F [19.4°C]			63°F [17.2°C]			
CFM [L/s]		1700 [802]	1550 [732]	1320 [623]	1700 [802]	1550 [732]	1320 [623]	1700 [802]	1550 [732]	1320 [623]	
DR ①		0.19	0.18	0.15	0.19	0.18	0.15	0.19	0.18	0.15	
OUTDOOR DRY BULB TEMPERATURE °F [°C]	75 [23.9]	Total BTUH [kW] Sens BTUH [kW] Power	58.3 [17.1] 33.2 [9.7] 2.7	57.3 [16.8] 31.8 [9.3] 2.6	55.8 [16.3] 29.6 [8.7] 2.6	54.6 [16.0] 39.2 [11.5] 2.7	53.7 [15.7] 37.5 [11.0] 2.6	52.2 [15.3] 34.9 [10.2] 2.6	51.6 [15.1] 44.7 [13.1] 2.6	50.7 [14.9] 42.8 [12.5] 2.6	49.3 [14.5] 39.8 [11.7] 2.6
	80 [26.7]	Total BTUH [kW] Sens BTUH [kW] Power	56.8 [16.7] 32.5 [9.5] 2.8	55.8 [16.4] 31.1 [9.1] 2.8	54.3 [15.9] 28.9 [8.5] 2.8	53.1 [15.6] 38.5 [11.3] 2.8	52.2 [15.3] 36.8 [10.8] 2.8	50.8 [14.9] 34.3 [10.0] 2.7	50.1 [14.7] 44.0 [12.9] 2.8	49.2 [14.4] 42.1 [12.3] 2.8	47.9 [14.0] 39.2 [11.5] 2.7
	85 [29.4]	Total BTUH [kW] Sens BTUH [kW] Power	55.3 [16.2] 31.7 [9.3] 3.0	54.3 [15.9] 30.3 [8.9] 2.9	52.8 [15.5] 28.2 [8.3] 2.9	51.5 [15.1] 37.7 [11.0] 2.9	50.6 [14.8] 36.0 [10.6] 2.9	49.3 [14.4] 33.6 [9.8] 2.9	48.5 [14.2] 43.2 [12.7] 2.9	47.7 [14.0] 41.3 [12.1] 2.9	46.4 [13.6] 38.4 [11.3] 2.9
	90 [32.2]	Total BTUH [kW] Sens BTUH [kW] Power	53.6 [15.7] 30.8 [9.0] 3.1	52.7 [15.4] 29.5 [8.6] 3.1	51.3 [15.0] 27.4 [8.0] 3.1	49.9 [14.6] 36.8 [10.8] 3.1	49.0 [14.4] 35.2 [10.3] 3.1	47.7 [14.0] 32.8 [9.6] 3.0	46.9 [13.7] 42.3 [12.4] 3.1	46.1 [13.5] 40.5 [11.9] 3.1	44.8 [13.1] 37.7 [11.0] 3.0
	95 [35]	Total BTUH [kW] Sens BTUH [kW] Power	51.9 [15.2] 29.9 [8.8] 3.3	51.0 [14.9] 28.6 [8.4] 3.3	49.6 [14.5] 26.6 [7.8] 3.2	48.2 [14.1] 35.9 [10.5] 3.3	47.3 [13.9] 34.3 [10.1] 3.3	46.1 [13.5] 32.0 [9.4] 3.2	45.2 [13.2] 41.4 [12.1] 3.3	44.4 [13.0] 39.6 [11.6] 3.3	43.2 [12.7] 36.8 [10.8] 3.2
	100 [37.8]	Total BTUH [kW] Sens BTUH [kW] Power	50.1 [14.7] 28.9 [8.5] 3.5	49.2 [14.4] 27.6 [8.1] 3.5	47.9 [14.0] 25.7 [7.5] 3.4	46.4 [13.6] 34.9 [10.2] 3.5	45.6 [13.4] 33.4 [9.8] 3.5	44.3 [13.0] 31.1 [9.1] 3.4	43.4 [12.7] 40.4 [11.8] 3.5	42.6 [12.5] 38.6 [11.3] 3.4	41.5 [12.2] 36.0 [10.5] 3.4
	105 [40.6]	Total BTUH [kW] Sens BTUH [kW] Power	48.2 [14.1] 27.8 [8.2] 3.7	47.4 [13.9] 26.6 [7.8] 3.7	46.1 [13.5] 24.8 [7.3] 3.6	44.5 [13.0] 33.8 [9.9] 3.7	43.7 [12.8] 32.4 [9.5] 3.7	42.6 [12.5] 30.1 [8.8] 3.6	41.5 [12.2] 39.3 [11.5] 3.7	40.8 [12.0] 37.6 [11.0] 3.7	39.7 [11.6] 35.0 [10.3] 3.6
	110 [43.3]	Total BTUH [kW] Sens BTUH [kW] Power	46.3 [13.6] 26.7 [7.8] 3.9	45.5 [13.3] 25.6 [7.5] 3.9	44.3 [13.0] 23.8 [7.0] 3.9	42.6 [12.5] 32.7 [9.6] 3.9	41.9 [12.3] 31.3 [9.2] 3.9	40.7 [11.9] 29.1 [8.5] 3.8	39.6 [11.6] 38.2 [11.2] 3.9	38.9 [11.4] 36.6 [10.7] 3.9	37.9 [11.1] 34.0 [10.0] 3.8
	115 [46.1]	Total BTUH [kW] Sens BTUH [kW] Power	44.3 [13.0] 25.5 [7.5] 4.2	43.5 [12.8] 24.4 [7.2] 4.2	42.4 [12.4] 22.7 [6.7] 4.1	40.6 [11.9] 31.6 [9.2] 4.2	39.9 [11.7] 30.2 [8.8] 4.1	38.8 [11.4] 28.1 [8.2] 4.1	37.6 [11.0] 37.1 [10.9] 4.2	36.9 [10.8] 35.5 [10.4] 4.1	35.9 [10.5] 33.0 [9.7] 4.1
	120 [48.9]	Total BTUH [kW] Sens BTUH [kW] Power	42.2 [12.4] 24.3 [7.1] 4.4	41.5 [12.2] 23.3 [6.8] 4.4	40.4 [11.8] 21.7 [6.3] 4.3	38.5 [11.3] 30.3 [8.9] 4.4	37.9 [11.1] 29.0 [8.5] 4.4	36.8 [10.8] 27.0 [7.9] 4.3	35.5 [10.4] 35.5 [10.4] 4.4	34.9 [10.2] 34.3 [10.0] 4.4	34.0 [10.0] 31.9 [9.3] 4.3
125 [51.7]	Total BTUH [kW] Sens BTUH [kW] Power	40.1 [11.8] 23.0 [6.7] 4.7	39.4 [11.5] 22.0 [6.5] 4.7	38.3 [11.2] 20.5 [6.0] 4.6	36.4 [10.7] 29.0 [8.5] 4.7	35.7 [10.5] 27.8 [8.1] 4.6	34.8 [10.2] 25.9 [7.6] 4.6	33.4 [9.8] 33.4 [9.8] 4.7	32.8 [9.6] 32.8 [9.6] 4.6	31.9 [9.4] 30.8 [9.0] 4.6	

DR —Depression ratio
dbE —Entering air dry bulb
wbE—Entering air wet bulb

Total —Total capacity x 1000 BTUH
Sens —Sensible capacity x 1000 BTUH
Power —KW input

NOTES: ① When the entering air dry bulb is other than 80°F [27°C], adjust the sensible capacity from the table by adding $[1.10 \times \text{CFM} \times (1 - \text{DR}) \times (\text{dbE} - 80)]$.

[] Designates Metric Conversions





GROSS SYSTEMS PERFORMANCE DATA—RACA15060A

ENTERING INDOOR AIR @ 80°F [26.7°C] dbE ①											
wbE		71°F [21.7°C]			67°F [19.4°C]			63°F [17.2°C]			
CFM [L/s]		2040 [963]	1850 [873]	1570 [741]	2040 [963]	1850 [873]	1570 [741]	2040 [963]	1850 [873]	1570 [741]	
DR ①		0.15	0.14	0.11	0.15	0.14	0.11	0.15	0.14	0.11	
OUTDOOR DRY BULB TEMPERATURE °F [°C]	75 [23.9]	Total BTUH [kW] Sens BTUH [kW] Power	73.0 [21.4] 42.4 [12.4] 3.6	71.7 [21.0] 40.5 [11.9] 3.6	69.7 [20.4] 37.6 [11.0] 3.5	69.2 [20.3] 50.0 [14.6] 3.6	67.9 [19.9] 47.7 [14.0] 3.5	66.0 [19.3] 44.3 [13.0] 3.5	65.8 [19.3] 56.9 [16.7] 3.5	64.6 [18.9] 54.3 [15.9] 3.5	62.8 [18.4] 50.5 [14.8] 3.4
	80 [26.7]	Total BTUH [kW] Sens BTUH [kW] Power	70.9 [20.8] 41.3 [12.1] 3.8	69.6 [20.4] 39.4 [11.6] 3.7	67.7 [19.8] 36.6 [10.7] 3.7	67.1 [19.6] 48.8 [14.3] 3.7	65.8 [19.3] 46.6 [13.7] 3.7	64.0 [18.8] 43.3 [12.7] 3.6	63.7 [18.7] 55.8 [16.4] 3.7	62.5 [18.3] 53.2 [15.6] 3.7	60.8 [17.8] 49.5 [14.5] 3.6
	85 [29.4]	Total BTUH [kW] Sens BTUH [kW] Power	68.8 [20.2] 40.1 [11.8] 4.0	67.6 [19.8] 38.3 [11.2] 3.9	65.7 [19.3] 35.6 [10.4] 3.9	64.9 [19.0] 47.7 [14.0] 3.9	63.7 [18.7] 45.5 [13.3] 3.9	62.0 [18.2] 42.3 [12.4] 3.8	61.5 [18.0] 54.6 [16.0] 3.9	60.4 [17.7] 52.1 [15.3] 3.8	58.8 [17.2] 48.5 [14.2] 3.8
	90 [32.2]	Total BTUH [kW] Sens BTUH [kW] Power	66.7 [19.5] 38.9 [11.4] 4.2	65.4 [19.2] 37.2 [10.9] 4.1	63.6 [18.6] 34.5 [10.1] 4.1	62.8 [18.4] 46.5 [13.6] 4.1	61.6 [18.1] 44.3 [13.0] 4.1	59.9 [17.6] 41.2 [12.1] 4.0	59.4 [17.4] 53.4 [15.7] 4.1	58.3 [17.1] 51.0 [14.9] 4.0	56.7 [16.6] 47.4 [13.9] 4.0
	95 [35]	Total BTUH [kW] Sens BTUH [kW] Power	64.5 [18.9] 37.7 [11.0] 4.4	63.3 [18.5] 36.0 [10.5] 4.3	61.5 [18.0] 33.4 [9.8] 4.3	60.6 [17.7] 45.2 [13.3] 4.3	59.5 [17.4] 43.2 [12.6] 4.3	57.8 [16.9] 40.1 [11.8] 4.2	57.2 [16.8] 52.2 [15.3] 4.3	56.1 [16.5] 49.8 [14.6] 4.3	54.6 [16.0] 46.3 [13.6] 4.2
	100 [37.8]	Total BTUH [kW] Sens BTUH [kW] Power	62.2 [18.2] 36.4 [10.7] 4.6	61.1 [17.9] 34.7 [10.2] 4.6	59.4 [17.4] 32.3 [9.5] 4.5	58.3 [17.1] 43.9 [12.9] 4.6	57.3 [16.8] 41.9 [12.3] 4.5	55.7 [16.3] 39.0 [11.4] 4.5	55.0 [16.1] 50.9 [14.9] 4.5	54.0 [15.8] 48.6 [14.2] 4.5	52.5 [15.4] 45.1 [13.2] 4.4
	105 [40.6]	Total BTUH [kW] Sens BTUH [kW] Power	60.0 [17.6] 35.1 [10.3] 4.9	58.9 [17.3] 33.5 [9.8] 4.8	57.3 [16.8] 31.1 [9.1] 4.8	56.1 [16.4] 42.6 [12.5] 4.8	55.1 [16.1] 40.7 [11.9] 4.8	53.5 [15.7] 37.8 [11.1] 4.7	52.7 [15.4] 49.6 [14.5] 4.8	51.8 [15.2] 47.3 [13.9] 4.8	50.3 [14.7] 44.0 [12.9] 4.7
	110 [43.3]	Total BTUH [kW] Sens BTUH [kW] Power	57.7 [16.9] 33.7 [9.9] 5.2	56.6 [16.6] 32.2 [9.4] 5.1	55.1 [16.1] 29.9 [8.8] 5.0	53.8 [15.8] 41.2 [12.1] 5.1	52.8 [15.5] 39.3 [11.5] 5.1	51.4 [15.1] 36.6 [10.7] 5.0	50.4 [14.8] 48.2 [14.1] 5.1	49.5 [14.5] 46.0 [13.5] 5.0	48.1 [14.1] 42.7 [12.5] 5.0
	115 [46.1]	Total BTUH [kW] Sens BTUH [kW] Power	55.4 [16.2] 32.3 [9.5] 5.4	54.4 [15.9] 30.8 [9.0] 5.4	52.9 [15.5] 28.6 [8.4] 5.3	51.5 [15.1] 39.8 [11.7] 5.4	50.5 [14.8] 38.0 [11.1] 5.4	49.2 [14.4] 35.3 [10.3] 5.3	48.1 [14.1] 46.8 [13.7] 5.4	47.2 [13.8] 44.6 [13.1] 5.3	45.9 [13.5] 41.5 [12.2] 5.2
	120 [48.9]	Total BTUH [kW] Sens BTUH [kW] Power	53.0 [15.5] 30.8 [9.0] 5.8	52.1 [15.3] 29.4 [8.6] 5.7	50.6 [14.8] 27.3 [8.0] 5.6	49.1 [14.4] 38.4 [11.2] 5.7	48.2 [14.1] 36.6 [10.7] 5.7	46.9 [13.7] 34.0 [10.0] 5.6	45.8 [13.4] 45.3 [13.3] 5.7	44.9 [13.2] 43.2 [12.7] 5.6	43.7 [12.8] 40.2 [11.8] 5.5
125 [51.7]	Total BTUH [kW] Sens BTUH [kW] Power	50.7 [14.8] 29.3 [8.6] 6.1	49.7 [14.6] 28.0 [8.2] 6.0	48.4 [14.2] 26.0 [7.6] 6.0	46.8 [13.7] 36.9 [10.8] 6.0	45.9 [13.5] 35.2 [10.3] 6.0	44.6 [13.1] 32.7 [9.6] 5.9	43.4 [12.7] 43.4 [12.7] 6.0	42.6 [12.5] 41.8 [12.3] 6.0	41.4 [12.1] 38.9 [11.4] 5.9	

DR —Depression ratio
dbE —Entering air dry bulb
wbE—Entering air wet bulb

Total —Total capacity x 1000 BTUH
Sens —Sensible capacity x 1000 BTUH
Power —KW input

NOTES: ① When the entering air dry bulb is other than 80°F [27°C], adjust the sensible capacity from the table by adding [1.10 x CFM x (1 – DR) x (dbE – 80)].

[] Designates Metric Conversions



INDOOR AIRFLOW PERFORMANCE RACA14 - 230 VOLTS

Nominal Cooling Capacity Tons [kW]	Motor Speed from Factory		Manufacturer Recommended Cooling Airflow (Min/Max)	Blower Size/ Motor HP [W] & # of Speeds	Motor Speed / Tap	External Static Pressure - Inches W.C. [kPa] (Side Discharge-Dry Coil)											
	Cool	Heat				0.1 [.02]	0.2 [.05]	0.3 [.07]	0.4 [.10]	0.5 [.12]	0.6 [.15]	0.7 [.17]	0.8 [.20]	0.9 [.22]	1.0 [.25]		
2 [7.03] 13 SEER	High	High	700 CFM / 950 CFM	9x7 Blower 1/4 HP [186] 2 Speed (PSC Motor)	Low	CFM	822 [388]	789 [372]	750 [354]	969 [328]	524 [294]	496 [294]	402 [234]				
						RPM	917	954	994	1031	1051	1075	1105				
						Watts	226	216	203	188	175	150	136				
2.5 [8.79]	Low	Low	850 CFM / 1150 CFM	10x7 Blower 1/2 HP [372] 3 Speed (PSC Motor)	Med	CFM	99 [468]	928 [438]	873 [412]	810 [382]	741 [350]	659 [311]	490 [231]				
						RPM	1055	1068	1080	1096	1106	1119	1136				
						Watts	271	256	245	227	214	199	175				
3.0 [10.55]	Low	Low	1000 CFM / 1400 CFM	12xGT Blower 1/2 HP [372] 2 Speed (PSC Motor)	High	CFM	1093 [516]	1062 [501]	1001 [472]	930 [439]	815 [385]	728 [344]	663 [313]				
						RPM	900	935	969	999	1030	1053	1064				
						Watts	375	358	335	313	283	264	249				
3.5 [12.31]	Tap 3	Tap 3	1200 CFM / 1600 CFM	12xGT Blower 3/4 HP [550] 3 Speed (PSC Motor)	Tap 3 High	CFM	1239 [585]	1184 [559]	1114 [526]	1043 [492]	959 [453]	827 [390]	744 [351]				
						RPM	961	983	1006	1030	1052	1074	1084				
						Watts	429	409	384	360	334	303	287				
3.0 [10.55]	Low	Low	1000 CFM / 1400 CFM	12xGT Blower 1/2 HP [372] 2 Speed (PSC Motor)	Low	CFM	1362 [643]	1292 [610]	1213 [572]	1133 [535]	1027 [485]	872 [412]	800 [378]				
						RPM	1049	1061	1073	1085	1087	1109	1116				
						Watts	500	472	545	427	405	371	360				
3.5 [12.31]	Tap 3	Tap 3	1200 CFM / 1600 CFM	12xGT Blower 3/4 HP [550] 3 Speed (PSC Motor)	Tap 1 Low	CFM	1310 [618]	1246 [588]	1186 [560]	1128 [532]	1038 [490]	955 [451]	847 [400]				
						RPM	834	867	895	918	949	971	989				
						Watts	460	447	435	424	407	396	380				
3.5 [12.31]	Tap 3	Tap 3	1200 CFM / 1600 CFM	12xGT Blower 3/4 HP [550] 3 Speed (PSC Motor)	Tap 2 Medium	CFM	1644 [776]	1568 [740]	1488 [702]	1421 [671]	1330 [628]	1248 [589]	1133 [535]				
						RPM	981	996	1009	1021	1030	1048	1058				
						Watts	664	641	620	602	585	568	545				
3.5 [12.31]	Tap 3	Tap 3	1200 CFM / 1600 CFM	12xGT Blower 3/4 HP [550] 3 Speed (PSC Motor)	Tap 3 High	CFM	1336 [631]	1312 [619]	1295 [611]	1241 [586]	1200 [566]	1161 [548]	1119 [528]				
						RPM	827	856	874	913	949	983	1013				
						Watts	298	308	313	325	341	352	361				
3.5 [12.31]	Tap 3	Tap 3	1200 CFM / 1600 CFM	12xGT Blower 3/4 HP [550] 3 Speed (PSC Motor)	Tap 3 High	CFM	1336 [631]	1312 [619]	1295 [611]	1241 [586]	1200 [566]	1161 [548]	1119 [528]				
						RPM	827	856	874	916	949	983	1013				
						Watts	298	308	313	325	341	352	361				
3.5 [12.31]	Tap 3	Tap 3	1200 CFM / 1600 CFM	12xGT Blower 3/4 HP [550] 3 Speed (PSC Motor)	Tap 3 High	CFM	1591 [751]	1563 [738]	1558 [735]	1519 [717]	1490 [703]	1458 [688]	1410 [665]				
						RPM	949	981	999	1027	1051	1086	1109				
						Watts	476	490	501	515	527	542	546				

Notes: (1) Set 2 through 4 ton Cool to Tap 2 for AHRI rated performance. (2) Set 5 ton 1st Stage Cool to Tap 1 for AHRI rated performance.

[] Designates Metric Conversions

INDOOR AIRFLOW PERFORMANCE RACA14 - 230 VOLTS (continued)

Nominal Cooling Capacity Tons [kW]	Motor Speed from Factory		Manufacturer Recommended Cooling Airflow (Min/Max)	Blower Size/ Motor HP [W] & # of Speeds	Motor Speed / Tap	External Static Pressure - Inches W.C. [kPa] (Side Discharge-Dry Coil)										
	Cool	Heat				0.1 [0.02]	0.2 [0.05]	0.3 [0.07]	0.4 [0.10]	0.5 [0.12]	0.6 [0.15]	0.7 [0.17]	0.8 [0.20]	0.9 [0.22]	1.0 [0.25]	
4.0 [14.07]	Tap 3	Tap 3	1350 CFM / 1850 CFM	12x9T Blower 3/4 HP [559] 3 Speed (PSC Motor)	Tap 1 Low	CFM	1467 [692]	1448 [683]	1404 [663]	1373 [648]	1339 [632]	1306 [616]	1250 [590]	1210 [571]	1164 [549]	1087 [513]
						RPM	826	855	774	910	939	969	1003	1030	1067	1108
						Watts	328	344	348	363	379	387	398	408	418	434
	Tap 3	Tap 3	1350 CFM / 1850 CFM	12x9T Blower 3/4 HP [559] 3 Speed (PSC Motor)	Tap 2 Medium	CFM	1634 [771]	1595 [753]	1547 [730]	1530 [722]	1487 [702]	1462 [690]	1438 [679]	1378 [650]	1352 [638]	1298 [613]
						RPM	894	923	950	981	1000	1030	1051	1079	1106	1126
						Watts	432	446	451	468	479	490	508	510	520	520
	Tap 3	Tap 3	1350 CFM / 1850 CFM	12x9T Blower 3/4 HP [559] 3 Speed (PSC Motor)	Tap 3 High	CFM	1941 [916]	1915 [904]	1878 [886]	1814 [856]	1773 [837]	1709 [807]	1655 [781]	1570 [741]	1488 [702]	1374 [648]
						RPM	1028	1047	1068	1091	1104	1113	1124	1136	1142	1147
						Watts	708	725	729	727	717	969	673	647	618	571
5.0 [17.59]	Tap 3	Tap 3	1600 CFM / 2100 CFM	12x9R Blower 1 HP [746] 3 Speed (PSC Motor)	Tap 1 Low	CFM	1768 [834]	1730 [816]	1693 [799]	1626 [767]	1599 [755]	1558 [735]	1522 [718]	1503 [709]	1444 [681]	1399 [660]
						RPM	938	959	983	1011	1025	1052	1089	1090	1117	1134
						Watts	520	533	541	560	563	578	599	599	605	615
	Tap 3	Tap 3	1600 CFM / 2100 CFM	12x9R Blower 1 HP [746] 3 Speed (PSC Motor)	Tap 2 Medium	CFM	1926 [909]	1890 [892]	1864 [880]	1822 [860]	1794 [847]	1758 [830]	1710 [807]	1670 [788]	1579 [745]	1493 [705]
						RPM	999	1014	1040	1061	1061	1096	1119	1128	1138	1144
						Watts	654	660	674	688	699	708	714	705	683	661
	Tap 3	Tap 3	1600 CFM / 2100 CFM	12x9R Blower 1 HP [746] 3 Speed (PSC Motor)	Tap 3 High	CFM	2096 [989]	2057 [971]	2003 [945]	1951 [921]	1890 [892]	1819 [858]	1756 [829]	1686 [796]	1610 [760]	1498 [707]
						RPM	1069	1092	1106	1116	1121	1129	1138	1140	1148	1154
						Watts	829	846	840	822	807	782	768	730	708	679

Notes: (1) Set 2 through 4 ton Cool to Tap 2 for AHRI rated performance. (2) Set 5 ton 1st Stage Cool to Tap 1 for AHRI rated performance.

DOWN DISCHARGE PRESSURE DROP (ADD TO EXTERNAL STATIC PRESSURE)

CFM [L/s]	800 [378]	1000 [472]	1200 [566]	1400 [661]	1600 [755]	1800 [849]	2000 [944]
Pressure Drop—Includes W.C. [kPa]	.02 [0.005]	.05 [0.012]	.07 [0.017]	.1 [0.025]	.12 [0.030]	.15 [0.037]	.17 [0.042]

[] Designates Metric Conversions

INDOOR AIRFLOW PERFORMANCE RACA14 - 208 VOLTS



Air

Indoor Airflow Performance
RACA14 Series

Nominal Cooling Capacity Tons [kW]	Motor Speed from Factory		Manufacturer Recommended Cooling Airflow (Min/Max)	Blower Size/ Motor HP [W] & # of Speeds	Motor Speed / Tap	External Static Pressure - Inches W.C. [kPa] (Side Discharge-Dry Coil)											
	Cool	Heat				0.1 [.02]	0.2 [.05]	0.3 [.07]	0.4 [.10]	0.5 [.12]	0.6 [.15]	0.7 [.17]	0.8 [.20]	0.9 [.22]	1.0 [.25]		
2.0 [7.03] 13 SEER	High	High	700 CFM / 950 CFM	9X7 Blower 1/4 HP [186] 2 Speed (PSC Motor)	Low	CFM	706 [333]	685 [323]	661 [312]	614 [290]	523 [247]	437 [206]	334 [158]				
						RPM	844	886	943	989	1036	1067	1095				
						Watts	202	193	182	169	151	135	120				
2.5 [8.79]	Low	Low	850 CFM / 1150 CFM	10X7 Blower 1/2 HP [372] 3 Speed (PSC Motor)	Med	CFM	925 [437]	874 [412]	813 [384]	763 [360]	681 [321]	534 [252]	441 [208]				
						RPM	1004	1027	1058	1070	1091	1116	1128				
						Watts	253	238	220	210	192	167	155				
3.0 [10.55]	Low	Low	1000 CFM / 1400 CFM	12xGT Blower 1/2 HP [372] 2 Speed (PSC Motor)	High	CFM	967 [456]	947 [447]	892 [421]	813 [384]	740 [349]	681 [321]	613 [289]	504 [238]			
						RPM	819	876	916	966	995	1018	1040				
						Watts	339	322	302	279	261	246	230				
3.5 [12.31]	Tap 3	Tap 3	1200 CFM / 1600 CFM	12xGT Blower 3/4 HP [559] 3 Speed (Constant Torque)	Tap 1 Low	CFM	1119 [528]	1081 [510]	1029 [486]	968 [457]	851 [402]	774 [365]	699 [330]	613 [289]			
						RPM	891	930	965	995	1026	1047	1059				
						Watts	391	375	354	330	297	278	263				
3.5 [12.31]	Tap 3	Tap 3	1200 CFM / 1600 CFM	12xGT Blower 3/4 HP [559] 3 Speed (Constant Torque)	Tap 2 Medium	CFM	1311 [619]	1249 [589]	1168 [551]	1089 [514]	985 [465]	861 [406]	779 [368]	699 [330]			
						RPM	1010	1031	1046	1066	1080	1095	1106				
						Watts	458	437	409	387	360	332	314				
3.5 [12.31]	Tap 3	Tap 3	1200 CFM / 1600 CFM	12xGT Blower 3/4 HP [559] 3 Speed (Constant Torque)	Tap 3 High	CFM	1163 [549]	1115 [526]	1075 [507]	1012 [478]	926 [437]	841 [397]	753 [355]	647 [305]			
						RPM	771	804	855	870	910	932	968				
						Watts	392	387	380	367	356	345	330				
3.5 [12.31]	Tap 3	Tap 3	1200 CFM / 1600 CFM	12xGT Blower 3/4 HP [559] 3 Speed (Constant Torque)	Tap 3 High	CFM	1543 [728]	1484 [700]	1422 [671]	1345 [635]	1251 [590]	1177 [555]	1071 [505]	939 [443]			
						RPM	939	957	975	1345	1251	1177	1037				
						Watts	586	572	555	555	525	517	481				
3.5 [12.31]	Tap 3	Tap 3	1200 CFM / 1600 CFM	12xGT Blower 3/4 HP [559] 3 Speed (Constant Torque)	Tap 1 Low	CFM	1346 [635]	1304 [615]	1264 [597]	1232 [581]	1185 [559]	1139 [538]	1092 [515]	1048 [495]	993 [469]	908 [429]	
						RPM	819	580	883	906	944	972	1014				
						Watts	291	302	310	319	333	338	353				
3.5 [12.31]	Tap 3	Tap 3	1200 CFM / 1600 CFM	12xGT Blower 3/4 HP [559] 3 Speed (Constant Torque)	Tap 2 Medium	CFM	1349 [635]	1304 [615]	1264 [597]	1232 [581]	1185 [559]	1139 [538]	1092 [515]	1048 [495]	993 [469]	908 [429]	
						RPM	819	850	883	906	944	972	1014				
						Watts	291	302	310	319	333	338	353				
3.5 [12.31]	Tap 3	Tap 3	1200 CFM / 1600 CFM	12xGT Blower 3/4 HP [559] 3 Speed (Constant Torque)	Tap 3 High	CFM	1596 [753]	1547 [730]	1520 [717]	1499 [707]	1471 [694]	1421 [671]	1383 [653]	1332 [629]	1262 [596]	1085 [512]	
						RPM	940	973	988	1020	1038	1068	1102				
						Watts	461	475	484	497	503	516	527				

Notes: (1) Set 2 through 4 ton Cool to Tap 2 for AHRI rated performance. (2) Set 5 ton 1st Stage Cool to Tap 1 for AHRI rated performance.

[] Designates Metric Conversions



INTEGRATED AIR & WATER

INDOOR AIRFLOW PERFORMANCE RACA14 - 208 VOLTS (continued)

Nominal Cooling Capacity Tons [kW]	Motor Speed from Factory		Manufacturer Recommended Cooling Airflow (Min/Max)	Blower Size/ Motor HP [W] & # of Speeds	Motor Speed / Tap	External Static Pressure - Inches W.C. [kPa] (Side Discharge-Dry Coil)										
	Cool	Heat				0.1 [0.02]	0.2 [0.05]	0.3 [0.07]	0.4 [0.10]	0.5 [0.12]	0.6 [0.15]	0.7 [0.17]	0.8 [0.20]	0.9 [0.22]	1.0 [0.25]	
4.0 [14.07]	Tap 3	Tap 3	1350 CFM / 1850 CFM	12x9T Blower 3/4 HP [559] 3 Speed (Constant Torque)	Tap 1 Low	CFM	1474 [696]	1431 [675]	1394 [658]	1355 [639]	1327 [626]	1284 [606]	1243 [587]	1198 [565]	1134 [535]	1057 [499]
						RPM	819	852	878	907	936	961	993	1024	1064	1101
						Watts	324	334	340	355	366	374	382	396	410	422
	Tap 3	Tap 3			Tap 2 Medium	CFM	1617 [763]	1585 [748]	1547 [730]	1512 [714]	1486 [701]	1449 [684]	1430 [675]	1355 [639]	1337 [631]	1280 [604]
						RPM	891	917	910	965	992	1015	1046	1080	1098	1123
						Watts	422	433	440	451	463	475	482	496	506	507
	Tap 3	Tap 3			Tap 3 High	CFM	1906 [900]	1876 [885]	1839 [868]	1807 [853]	1756 [829]	1697 [801]	1642 [775]	1555 [734]	1482 [699]	1372 [648]
						RPM	1021	1043	1061	1079	1097	1110	1123	1128	1140	1145
						Watts	679	699	694	707	698	686	671	635	610	566
5.0 [17.59]	Tap 3	Tap 3	1600 CFM / 2100 CFM	12x9R Blower 1 HP [746] 3 Speed (Constant Torque)	Tap 1 Low	CFM	1738 [820]	1680 [793]	1663 [785]	1626 [767]	1603 [757]	1554 [733]	1503 [709]	1445 [682]	1432 [676]	1386 [654]
						RPM	933	969	979	1001	1021	1045	1066	1100	1104	1125
						Watts	505	526	529	541	545	562	567	585	586	593
	Tap 3	Tap 3			Tap 2 Medium	CFM	1884 [889]	1882 [888]	1841 [869]	1801 [850]	1760 [831]	1680 [793]	1651 [779]	1584 [748]	1508 [712]	1428 [674]
						RPM	999	1014	1048	1064	1072	1105	1121	1131	1142	1147
						Watts	636	646	661	672	675	688	686	678	662	635
	Tap 3	Tap 3			Tap 3 High	CFM	2081 [982]	1969 [929]	2001 [994]	1960 [925]	1896 [895]	1818 [858]	1764 [833]	1664 [785]	1593 [752]	1499 [707]
						RPM	1050	1102	1095	1104	1115	1126	1130	1140	1143	1147
						Watts	790	815	819	813	793	772	749	725	699	663

Notes: (1) Set 2 through 4 ton Cool to Tap 2 for AHRI rated performance. (2) Set 5 ton 1st Stage Cool to Tap 1 for AHRI rated performance.

DOWN DISCHARGE PRESSURE DROP (ADD TO EXTERNAL STATIC PRESSURE)			
CFM [L/s]	800 [378]	1000 [472]	1200 [566]
Pressure Drop—Includes W.C. [kPa]	.02 [.005]	.05 [.012]	.07 [.017]
	1400 [661]	1600 [755]	1800 [849]
	.1 [.025]	.12 [.030]	.15 [.037]
	2000 [944]	2000 [944]	2000 [944]
	.17 [.042]		

[] Designates Metric Conversions

INDOOR AIRFLOW PERFORMANCE RACA15 - 208/230 VOLTS

Nominal Cooling Capacity Tons [kW]	Motor Speed from Factory		Manufacturer Recommended Cooling Airflow (Min/Max)	Blower Size/ Motor HP [W] & # of Speeds	Motor Speed / Tap	External Static Pressure - Inches W.C. [kPa] (Side Discharge-Dry Coil)																	
	Cool	Heat				0.1 [.02]	0.2 [.05]	0.3 [.07]	0.4 [.10]	0.5 [.12]	0.6 [.15]	0.7 [.17]	0.8 [.20]	0.9 [.22]	1.0 [.25]								
2.0 [7.03] 13 SEER	Tap 3	High	700 CFM / 950 CFM	10X9 Blower 1/3 HP [249] 3 Speed (Constant Torque)	Tap 1 Low	CFM	917 [433]	865 [408]	826 [390]	771 [364]	730 [345]	677 [320]	628 [296]	596 [281]									
						RPM	772	810	860	905	945	985	1013	1052									
						Watts	142	149	159	164	175	177	180	189									
2.5 [8.79]	Tap 3	Low	850 CFM / 1150 CFM	10X9 Blower 1/3 HP [249] 3 Speed (Constant Torque)	Tap 2 Medium	CFM	931 [439]	880 [415]	854 [403]	795 [375]	743 [351]	694 [328]	655 [309]	608 [287]									
						RPM	789	1425	874	921	965	1002	1041	1070									
						Watts	155	159	170	176	185	188	196	200									
3.0 [10.55]	Tap 3	Low	1000 CFM / 1400 CFM	12xGT Blower 1/2 HP [372] 3 Speed (Constant Torque)	Tap 3 High	CFM	1005 [474]	956 [451]	916 [432]	878 [414]	808 [381]	778 [367]	734 [346]	698 [329]									
						RPM	822	872	407	954	998	1036	1070	1103									
						Watts	178	192	198	208	212	224	224	234									
3.5 [12.31]	Tap 3	Tap 3	1200 CFM / 1600 CFM	12xGT Blower 3/4 HP [559] 3 Speed (PSC Motor)	Tap 1 Low	CFM	917 [433]	865 [408]	826 [390]	771 [364]	730 [345]	677 [320]	628 [296]	596 [281]									
						RPM	772	810	860	905	945	985	1013	1052									
						Watts	142	149	159	164	175	177	180	189									
3.5 [12.31]	Tap 3	Tap 3	1200 CFM / 1600 CFM	12xGT Blower 3/4 HP [559] 3 Speed (PSC Motor)	Tap 2 Medium	CFM	1013 [478]	980 [463]	939 [443]	893 [421]	864 [408]	792 [374]	752 [355]	687 [324]									
						RPM	820	854	901	934	976	1022	1064	1097									
						Watts	171	177	187	190	202	207	217	222									
3.5 [12.31]	Tap 3	Tap 3	1200 CFM / 1600 CFM	12xGT Blower 3/4 HP [559] 3 Speed (PSC Motor)	Tap 3 High	CFM	1227 [579]	1180 [557]	1160 [547]	1123 [530]	1090 [514]	1054 [497]	1008 [476]	882 [416]									
						RPM	930	976	1006	1029	1065	1089	1124	1154									
						Watts	264	276	288	291	300	305	311	292									
3.5 [12.31]	Tap 3	Tap 3	1200 CFM / 1600 CFM	12xGT Blower 3/4 HP [559] 3 Speed (PSC Motor)	Tap 1 Low	CFM	1108 [523]	1081 [510]	1040 [491]	961 [449]	916 [432]	857 [404]	776 [366]	722 [341]									
						RPM	713	752	796	845	873	920	966	1001									
						Watts	188	199	213	222	229	241	252	261									
3.5 [12.31]	Tap 3	Tap 3	1200 CFM / 1600 CFM	12xGT Blower 3/4 HP [559] 3 Speed (PSC Motor)	Tap 2 Medium	CFM	1169 [552]	1115 [526]	1086 [513]	1047 [949]	983 [464]	931 [439]	855 [404]	784 [370]									
						RPM	749	803	819	856	901	938	985	1029									
						Watts	217	231	233	246	259	266	277	289									
3.5 [12.31]	Tap 3	Tap 3	1200 CFM / 1600 CFM	12xGT Blower 3/4 HP [559] 3 Speed (PSC Motor)	Tap 3 High	CFM	1434 [677]	1419 [670]	1387 [655]	1340 [632]	1310 [618]	1258 [594]	1198 [566]	1160 [547]									
						RPM	866	882	920	944	981	1008	1051	1078									
						Watts	372	377	390	366	413	421	426	443	445								
3.5 [12.31]	Tap 3	Tap 3	1200 CFM / 1600 CFM	12xGT Blower 3/4 HP [559] 3 Speed (PSC Motor)	Tap 1 Low	CFM	1336 [631]	1312 [619]	1295 [611]	1241 [586]	1200 [566]	1161 [548]	1119 [528]	1072 [506]									
						RPM	827	856	874	913	949	983	1013	1048									
						Watts	298	308	313	325	341	352	361	374	387								
3.5 [12.31]	Tap 3	Tap 3	1200 CFM / 1600 CFM	12xGT Blower 3/4 HP [559] 3 Speed (PSC Motor)	Tap 2 Medium	CFM	1336 [631]	1312 [619]	1295 [611]	1241 [586]	1200 [566]	1161 [548]	1119 [528]	1072 [506]									
						RPM	827	856	874	913	949	983	1013	1048									
						Watts	298	308	313	325	341	352	361	374	387								
3.5 [12.31]	Tap 3	Tap 3	1200 CFM / 1600 CFM	12xGT Blower 3/4 HP [559] 3 Speed (PSC Motor)	Tap 3 High	CFM	1591 [751]	1563 [738]	1558 [735]	1519 [717]	1490 [703]	1458 [688]	1410 [665]	1363 [643]									
						RPM	949	981	999	1027	1051	1086	1109	1129									
						Watts	476	490	501	515	527	542	546	543	522								

Notes: (1) Set 2 through 4 ton Cool to Tap 2 for AHRI rated performance. (2) Set 5 ton 1st Stage Cool to Tap 1 for AHRI rated performance.

[] Designates Metric Conversions

INDOOR AIRFLOW PERFORMANCE RACA15 - 208/230 VOLTS (continued)

Nominal Cooling Capacity Tons [kW]	Motor Speed from Factory		Manufacturer Recommended Cooling Airflow (Min/Max)	Blower Size/ Motor HP [W] & # of Speeds	Motor Speed / Tap	External Static Pressure - Inches W.C. [kPa] (Side Discharge-Dry Coil)										
	Cool	Heat				0.1 [0.02]	0.2 [0.05]	0.3 [0.07]	0.4 [0.10]	0.5 [0.12]	0.6 [0.15]	0.7 [0.17]	0.8 [0.20]	0.9 [0.22]	1.0 [0.25]	
4.0 [14.07]	Tap 3	Tap 3	1350 CFM / 1850 CFM	12x9T Blower 3/4 HP [559] 3 Speed (Constant Torque)	Tap 1 Low	CFM	1467 [692]	1448 [683]	1404 [663]	1373 [648]	1339 [632]	1306 [616]	1250 [590]	1210 [571]	1164 [549]	1087 [513]
						RPM	826	855	884	910	939	969	1003	1030	1067	1108
						Watts	328	344	348	363	379	387	398	408	418	434
	Tap 3	Tap 3	1350 CFM / 1850 CFM	12x9T Blower 3/4 HP [559] 3 Speed (Constant Torque)	Tap 2 Medium	CFM	1634 [771]	1595 [753]	1547 [730]	1530 [722]	1487 [702]	1462 [690]	1438 [679]	1378 [650]	1352 [638]	1298 [613]
						RPM	894	923	950	981	1000	1030	1051	1079	1106	1126
						Watts	432	446	451	468	479	490	508	510	520	520
Tap 3	Tap 3	1350 CFM / 1850 CFM	12x9T Blower 3/4 HP [559] 3 Speed (Constant Torque)	Tap 3 High	CFM	1941 [916]	1915 [904]	1878 [886]	1814 [856]	1773 [837]	1709 [807]	1655 [781]	1570 [741]	1488 [702]	1374 [648]	
					RPM	1028	1047	1068	1091	1104	1113	1124	1136	1142	1147	
					Watts	708	725	729	727	717	696	673	647	618	571	
5.0 [17.59]	1st Stage Tap 2	Tap 1	1600 CFM / 2100 CFM	12x9R Blower 1 HP [746] 5 Speed (Constant Torque)	Tap 1 Heat / 1st Stg Cool	CFM	1233 [582]	1158 [547]	1136 [536]	1090 [514]	1039 [490]	969 [457]	902 [426]	847 [400]	791 [373]	752 [355]
						RPM	734	774	793	822	860	892	934	957	983	1011
						Watts	223	231	238	248	259	269	288	284	295	306
						CFM	1433 [676]	1407 [664]	1354 [639]	1329 [627]	1270 [599]	1235 [583]	1195 [564]	1137 [537]	1083 [511]	1030 [486]
						RPM	821	843	868	888	929	944	975	1004	1040	1065
						Watts	319	331	342	346	365	368	381	391	406	412
	1st Stage Tap 2	Tap 1	1600 CFM / 2100 CFM	12x9R Blower 1 HP [746] 5 Speed (Constant Torque)	Tap 2 Heat / 1st Stg Cool	CFM	1768 [834]	1730 [816]	1693 [799]	1626 [767]	1599 [755]	1558 [735]	1522 [718]	1503 [709]	1444 [681]	1399 [660]
						RPM	938	959	938	1011	1025	1052	1089	1090	1117	1134
						Watts	520	533	541	560	563	578	599	599	605	615
						CFM	1926 [909]	1890 [892]	1864 [880]	1822 [860]	1794 [847]	1758 [830]	1710 [807]	1670 [788]	1579 [745]	1493 [705]
						RPM	999	1014	1040	1061	1079	1096	1119	1128	1138	1144
						Watts	654	660	674	688	699	708	714	705	683	661
2nd Stage Tap 4	Tap 4	1600 CFM / 2100 CFM	12x9R Blower 1 HP [746] 5 Speed (Constant Torque)	Tap 5 High / 2nd Stage Static Cool	CFM	2096 [989]	2057 [971]	2003 [945]	1951 [921]	1890 [892]	1819 [858]	1756 [829]	1686 [796]	1610 [760]	1498 [707]	
					RPM	1069	1092	1106	1116	1121	1129	1138	1140	1148	1154	
					Watts	829	846	840	822	807	782	768	730	708	679	

Notes: (1) Set 2 through 4 ton Cool to Tap 2 for AHRI rated performance. (2) Set 5 ton 1st Stage Cool to Tap 1 for AHRI rated performance.

DOWN DISCHARGE PRESSURE DROP (ADD TO EXTERNAL STATIC PRESSURE)			
CFM [L/s]	800 [378]	1000 [472]	1200 [566]
Pressure Drop—Includes W.C. [kPa]	.02 [0.005]	.05 [0.012]	.07 [0.017]
	.1 [0.025]	.12 [0.030]	.15 [0.037]
		.17 [0.042]	

[] Designates Metric Conversions

ELECTRICAL DATA – RACA14 SERIES										
		024AJD***AA	024AJT***AA	024BJT***AA	030AJD***AA	030BJT***AA	036ACD***AA	036AJD***AA	036BCT***AA	036BJT***AA
Unit Information	Unit Operating Voltage Range	187-253	187-253	187-253	187-253	187-253	187-253	187-253	187-253	187-253
	Volts	208/230	208/230	208/230	208/230	208/230	208/230	208/230	208/230	208/230
	Phase	1	1	1	1	1	3	1	3	1
	Hz	60	60	60	60	60	60	60	60	60
	Minimum Circuit Ampacity	17	19	19	20	21	16	22	17	24
	Minimum Overcurrent Protection Device Size	20	20	20	20	25	20	25	20	25
	Maximum Overcurrent Protection Device Size	25	25	25	30	30	20	35	25	35
Compressor Motor	No.	1	1	1	1	1	1	1	1	1
	Volts	208/230	208/230	208/230	208/230	208/230	208/230	208/230	208/230	208/230
	Phase	1	1	1	1	1	3	1	3	1
	RPM	3450	3450	3450	3450	3450	3450	3450	3450	3450
	HP, Compressor 1	2 1/6	2 1/6	2 1/6	2 2/3	2 2/3	3 1/3	3 1/3	3 1/3	3 1/3
	Amps (RLA), Comp. 1	11.2	11.2	11.2	12.8	12.8	9	14.1	9	14.1
	Amps (LRA), Comp. 1	60.8	60.8	60.8	64	64	71	77	71	77
	HP, Compressor 2									
	Amps (RLA), Comp. 2									
Amps (LRA), Comp. 2										
Condenser Motor	No.	1	1	1	1	1	1	1	1	1
	Volts	208/230	208/231	208/232	208/233	208/234	208/235	208/236	208/237	208/238
	Phase	1	1	1	1	1	1	1	1	1
	HP	1/3	1/3	1/3	1/3	1/3	1/3	1/3	1/3	1/3
	Amps (FLA, each)	1.5	1.5	1.5	1.5	1.5	1.5	1.5	1.5	1.5
	Amps (LRA, each)	3	3	3	3	3	3	3	3	3
Evaporator Fan	No.	1	1	1	1	1	1	1	1	1
	Volts	208/230	208/231	208/232	208/233	208/234	208/235	208/236	208/237	208/238
	Phase	1	1	1	1	1	1	1	1	1
	HP	1/4	1/3	1/3	1/2	1/2	1/2	1/2	1/2	1/2
	Amps (FLA, each)	1.3	2.8	2.8	2.4	2.8	2.5	2.5	4.1	4.1
	Amps (LRA, each)	2.3			5.1		4.6	4.6		

1. Horsepower Per Compressor.

2. Amp Draw Per Motor. Multiply Value By Number of Motors to Determine Total Amps.

ELECTRICAL DATA – RACA14 SERIES

		042ACT***AA	042AJT***AA	048ACT***AA	048AJT***AA	048BCT***AA	048BJT***AA	060ACT***AA	060AJT***AA
Unit Information	Unit Operating Voltage Range	187-253	187-253	187-253	187-253	187-253	187-253	197-253	197-253
	Volts	208/230	208/230	208/230	208/230	208/230	208/230	208/230	208/230
	Phase	3	1	3	1	3	1	3	1
	Hz	60	60	60	60	60	60	60	60
	Minimum Circuit Ampacity	24	30	25	33	25	33	32	41
	Minimum Overcurrent Protection Device Size	25	30	25	35	25	35	35	45
	Maximum Overcurrent Protection Device Size	35	45	35	50	35	50	45	60
Compressor Motor	No.	1	1	1	1	1	1	1	1
	Volts	208/230	208/230	208/230	208/230	208/230	208/230	208/230	208/230
	Phase	3	1	3	1	3	1	3	1
	RPM	3450	3451	3452	3453	3454	3455	3456	3457
	HP, Compressor 1	3 1/2	3 1/2	4	4	4	4	5	5
	Amps (RLA), Comp. 1	13.2	17.9	13.1	19.9	13.1	19.9	17.8	24.4
	Amps (LRA), Comp. 1	88	112	83.1	109	83.1	1109	110	144.2
	HP, Compressor 2								
	Amps (RLA), Comp. 2								
Amps (LRA), Comp. 2									
Condenser Motor	No.	1	1	1	1	1	1	1	1
	Volts	208/230	208/230	208/230	208/230	208/230	208/230	208/230	208/230
	Phase	1	1	1	1	1	1	1	1
	HP	1/3	1/3	1/3	1/3	1/3	1/3	1/3	1/3
	Amps (FLA, each)	1.5	1.5	2	2	2	2	2	2
	Amps (LRA, each)	3	3	3.9	3.9	3.9	3.9	3.9	3.9
Evaporator Fan	No.	1	1	1	1	1	1	1	1
	Volts	208/230	208/230	208/230	208/230	208/230	208/230	208/230	208/230
	Phase	1	1	1	1	1	1	1	1
	HP	3/4	3/4	3/4	3/4	3/4	3/4	1	1
	Amps (FLA, each)	6	6	6	6	6	6	7.6	7.6
Amps (LRA, each)									

1. Horsepower Per Compressor.
2. Amp Draw Per Motor. Multiply Value By Number of Motors to Determine Total Amps.

ELECTRICAL DATA – RACA15 SERIES										
		024AJT***AA	030AJT***AA	036ACT***AA	036AJT***AA	042ACT***AA	042AJT***AA	048ACT***AA	048AJT***AA	060ACT***AA
Unit Information	Unit Operating Voltage Range	187-253	187-253	187-253	187-253	187-253	187-253	187-253	187-253	197-253
	Volts	208/230	208/230	208/230	208/230	208/230	208/230	208/230	208/230	208/230
	Phase	1	1	3	1	3	1	3	1	3
	Hz	60	60	60	60	60	60	60	60	60
	Minimum Circuit Ampacity	19	21	17	24	24	30	25	33	30
	Minimum Overcurrent Protection Device Size	20	25	20	25	25	30	25	35	50
	Maximum Overcurrent Protection Device Size	25	30	25	35	35	45	35	50	45
Compressor Motor	No.	1	1	1	1	1	1	1	1	1
	Volts	208/230	208/230	208/230	208/230	208/230	208/230	208/230	208/230	208/230
	Phase	1	1	3	1	3	1	3	1	3
	RPM	3450	3450	3450	3450	3450	3450	3450	3450	3450
	HP, Compressor 1	2 1/6	2 2/3	3 1/3	3 1/3	3 1/2	3 1/2	4	4	5
	Amps (RLA), Comp. 1	11.2	12.8	9	14.1	13.2	17.9	13.1	19.9	16.2
	Amps (LRA), Comp. 1	60.8	64	71	77	99	112	93.1	109	110
	HP, Compressor 2									
	Amps (RLA), Comp. 2									
Amps (LRA), Comp. 2										
Condenser Motor	No.	1	1	1	1	1	1	1	1	1
	Volts	208/230	208/230	208/230	208/230	208/230	208/230	208/230	208/230	208/230
	Phase	1	1	1	1	1	1	1	1	1
	HP	1/3	1/3	1/3	1/3	1/3	1/3	1/3	1/3	1/3
	Amps (FLA, each)	1.5	1.5	1.5	1.5	1.5	1.5	1.5	2	2
	Amps (LRA, each)	3	3	3	3	3	3	3.9	3.9	3.9
Evaporator Fan	No.	1	1	1	1	1	1	1	1	1
	Volts	208/230	208/230	208/230	208/230	208/230	208/230	208/230	208/230	208/230
	Phase	1	1	1	1	1	1	1	1	1
	HP	1/3	1/2	1/2	1/2	3/4	3/4	3/4	3/4	1
	Amps (FLA, each)	2.8	2.8	4.1	4.1	6	6	6	6	7.6
	Amps (LRA, each)									

1. Horsepower Per Compressor.

2. Amp Draw Per Motor. Multiply Value By Number of Motors to Determine Total Amps.

208/240 VOLT, SINGLE PHASE, 60 Hz, AUXILIARY ELECTRIC HEATER KITS CHARACTERISTICS AND APPLICATION

Single Power Supply for Both Unit and Heater Kit										Separate Power Supply for Both Unit and Heater Kit				
Model No.	RXQJ-Heater Kit Nominal kW	No. of Sequence Steps	Rated Heater kW @ 208/240V	Heater kBTU/Hr @ 208/240V	Heater Amp @ 208/240V	Unit Min. Ampacity @ 208/240V	Air Conditioner		Heater Kit		Air Conditioner		Over Current Protective Device Size Min./Max. @ 240V	
							Min. Ampacity @ 208V	Max. Ampacity @ 208V	Min. Ckt. Ampacity 208/240V	Max. Fuse Size 208/240V	Min. Circuit Ampacity 208/240V	Over Current Protective Device Size Min./Max. @ 208V		
RACA14024AJD000AA	No Heat	-----	---	---	---	17/17	20/25	20/25	---	---	17/17	20/25	20/25	
RACA14024AJD051AA	A05J	1	3.6/4.8	12.28/16.38	17.3/20.0	24/27	25/25	30/30	22/25	25/25	17/17	20/25	20/25	
RACA14024AJD101AA	A10J	1	7.2/9.6	24.57/32.76	34.6/40.0	45/52	45/45	60/60	44/50	45/50	17/17	20/25	20/25	
RACA14024AJT000AA	No Heat	---	---	---	---	19/19	20/25	20/25	---	---	19/19	20/25	20/25	
RACA14024AJT051AA	A05J	1	3.6/4.8	12.28/16.38	17.3/20.0	26/29	30/30	30/30	22/25	25/25	19/19	20/25	20/25	
RACA14024AJT101AA	A10J	1	7.2/9.6	24.57/32.76	34.6/40.0	47/54	50/50	60/60	44/50	45/50	19/19	20/25	20/25	
RACA14030AJD000AA	No Heat	---	---	---	---	20/20	20/30	20/30	---	---	20/20	20/30	20/30	
RACA14030AJD051AA	A05J	1	3.6/4.8	12.28/16.38	17.3/20.0	25/28	25/30	30/30	22/25	25/25	20/20	20/30	20/30	
RACA14030AJD101AA	A10J	1	7.2/9.6	24.57/32.76	34.6/40.0	47/53	50/50	60/60	44/50	45/50	20/20	20/30	20/30	
RACA14030AJT000AA	No Heat	---	---	---	---	21/21	25/30	25/30	---	---	21/21	25/30	25/30	
RACA14030AJT051AA	A05J	1	3.6/4.8	12.28/16.38	17.3/20.0	26/29	30/30	30/30	22/25	25/25	21/21	25/30	25/30	
RACA14030AJT101AA	A10J	1	7.2/9.6	24.57/32.76	34.6/40.0	47/54	50/50	60/60	44/50	45/50	21/21	25/30	25/30	
RACA14036AJD000AA	No Heat	---	---	---	---	22/22	25/35	25/35	---	---	22/22	25/35	25/35	
RACA14036AJD051AA	A05J	1	3.6/4.8	12.28/16.38	17.3/20.0	25/29	25/35	30/35	22/25	25/25	22/22	25/35	25/35	
RACA14036AJD101AA	A10J	1	7.2/9.6	24.57/32.76	34.6/40.0	47/54	50/50	60/60	44/50	45/50	22/22	25/35	25/35	
RACA14036AJD151AA	A15J	1	10.8/14.4	36.85/49.13	51.9/60.0	68/79	70/70	80/80	65/75	70/80	22/22	25/35	25/35	
RACA14036BJT000AA	No Heat	---	---	---	---	24/24	25/35	25/35	---	---	24/24	25/35	25/35	
RACA14036BJT051AA	A05J	1	3.6/4.8	12.28/16.38	17.3/20.0	27/31	30/35	35/35	22/25	25/25	24/24	25/35	25/35	
RACA14036BJT101AA	A10J	1	7.2/9.6	24.57/32.76	34.6/40.0	49/56	50/50	60/60	44/50	45/50	24/24	25/35	25/35	
RACA14036BJT151AA	A15J	1	10.8/14.4	36.85/49.13	51.9/60.0	70/81	70/70	90/90	65/75	70/80	24/24	25/35	25/35	
RACA14042AJT000AA	No Heat	---	---	---	---	30/30	30/45	30/45	---	---	30/30	30/45	30/45	
RACA14042AJT051AA	A05J	1	3.6/4.8	12.28/16.38	17.3/20.0	30/33	30/45	35/45	22/25	25/25	30/30	30/45	30/45	
RACA14042AJT101AA	B10J	1	7.2/9.6	24.57/32.76	34.6/40.0	51/58	60/60	60/60	44/50	45/50	30/30	30/45	30/45	
RACA14042AJT151AA	B15J	1	10.8/14.4	36.85/49.13	51.9/60.0	73/83	80/80	90/90	65/75	70/80	30/30	30/45	30/45	
RACA14048AJT000AA	No Heat	---	---	---	---	33/33	35/50	35/50	---	---	33/33	35/50	35/50	
RACA14048AJT051AA	A05J	1	3.6/4.8	12.28/16.38	17.3/20.0	33/33	35/50	35/50	22/25	25/25	33/33	35/50	35/50	
RACA14048AJT101AA	B10J	1	7.2/9.6	24.57/32.76	34.6/40.0	51/58	60/60	60/60	44/50	45/50	33/33	35/50	35/50	
RACA14048AJT151AA	B15J	1	10.8/14.4	36.85/49.13	51.9/60.0	73/83	80/80	90/90	65/75	70/80	33/33	35/50	35/50	
RACA14060AJT000AA	No Heat	---	---	---	---	33/33	35/50	35/50	---	---	33/33	35/50	35/50	
RACA14060AJT051AA	A05J	1	3.6/4.8	12.28/16.38	17.3/20.0	33/33	35/50	35/50	22/25	25/25	33/33	35/50	35/50	
RACA14060AJT101AA	B10J	1	7.2/9.6	24.57/32.76	34.6/40.0	51/58	60/60	60/60	44/50	45/50	33/33	35/50	35/50	
RACA14060AJT151AA	B15J	1	10.8/14.4	36.85/49.13	51.9/60.0	73/83	80/80	90/90	65/75	70/80	33/33	35/50	35/50	
RACA14060AJT000AA	No Heat	---	---	---	---	41/41	45/60	45/60	---	---	41/41	45/60	45/60	
RACA14060AJT051AA	A05J	1	3.6/4.8	12.28/16.38	17.3/20.0	41/41	45/60	45/60	22/25	25/25	41/41	45/60	45/60	
RACA14060AJT101AA	B10J	1	7.2/9.6	24.57/32.76	34.6/40.0	53/60	60/60	60/60	44/50	45/50	41/41	45/60	45/60	
RACA14060AJT151AA	B15J	1	10.8/14.4	36.85/49.13	51.9/60.0	75/85	80/80	90/90	65/75	70/80	41/41	45/60	45/60	
RACA14036ACD000AA	No Heat	---	---	---	---	16/16	20/20	20/20	---	---	16/16	20/20	20/20	
RACA14036ACD101AA	A10C	1	7.2/9.6	24.57/32.76	20.0/23.1	29/32	30/30	35/35	25/29	25/30	16/16	20/20	20/20	
RACA14036ACD151AA	A15C	1	10.8/14.4	36.85/49.13	30.1/34.7	41/47	45/45	50/50	38/44	40/45	16/16	20/20	20/20	
RACA14036BCT000AA	No Heat	---	---	---	---	17/17	20/25	20/25	---	---	17/17	20/25	20/25	
RACA14036BCT101AA	A10C	1	7.2/9.6	24.57/32.76	20.0/23.1	31/34	35/35	35/35	25/29	25/30	17/17	20/25	20/25	

208/240 VOLT, SINGLE PHASE, 60 Hz, AUXILIARY ELECTRIC HEATER KITS CHARACTERISTICS AND APPLICATION																	
Separate Power Supply for Both Unit and Heater Kit																	
Single Power Supply for Both Unit and Heater Kit						Heater Kit			Air Conditioner			Heater Kit			Air Conditioner		
Model No.	RXDJ-Heater Kit Nominal kW	No. of Sequence Steps	Rated Heater kW @ 208/240V	Heater kBTU/Hr @ 208/240V	Heater Amp @ 208/240V	Unit Min. Ampacity @ 208/240V	Over Current Protective Device Size		Min. Ckt. Ampacity 208/240V	Max. Fuse Size 208/240V	Min. Circuit Ampacity 208/240V	Over Current Protective Device Size					
							Min./Max. @ 208V	Min./Max. @ 240V				Min./Max. @ 208V	Min./Max. @ 240V				
RACA14036BCT151AA	A15C	1	10.8/14.4	36.85/49.13	30.1/34.7	43/49	45/45	50/50	38/44	40/45	17/17	20/25	20/25	20/25			
RACA14042ACT000AA	No Heat	—	—	—	—	24/24	25/35	25/35	—	—	24/24	25/35	25/35	25/35			
RACA14042ACT101AA	A10C	1	7.2/9.6	24.57/32.76	20.0/23.1	33/37	35/35	40/40	25/29	25/30	24/24	25/35	25/35	25/35			
RACA14042ACT151AA	A15C	1	10.8/14.4	36.85/49.13	30.1/34.7	46/51	50/50	60/60	38/44	40/45	24/24	25/35	25/35	25/35			
RACA14048ACT000AA	No Heat	—	—	—	—	25/25	25/35	25/35	—	—	25/25	25/35	25/35	25/35			
RACA14048ACT101AA	A10C	1	7.2/9.6	24.57/32.76	20.0/23.1	33/37	35/35	40/40	25/29	25/30	25/25	25/35	25/35	25/35			
RACA14048ACT151AA	A15C	1	10.8/14.4	36.85/49.13	30.1/34.7	46/51	50/50	60/60	38/44	40/45	25/25	25/35	25/35	25/35			
RACA14048BCT101AA	No Heat	—	—	—	—	25/25	25/35	25/35	—	—	25/25	25/35	25/35	25/35			
RACA14048BCT151AA	A10C	1	7.2/9.6	24.57/32.76	20.0/23.1	33/37	35/35	40/40	25/29	25/30	25/25	25/35	25/35	25/35			
RACA14048BCT151AA	A15C	1	10.8/14.4	36.85/49.13	30.1/34.7	46/51	50/50	60/60	38/44	40/45	25/25	25/35	25/35	25/35			
RACA14060ACT000AA	No Heat	—	—	—	—	32/32	35/45	35/45	—	—	32/32	35/45	35/45	35/45			
RACA14060ACT101AA	A10C	1	7.2/9.6	24.57/32.76	20.0/23.1	35/39	35/45	40/45	25/29	25/30	32/32	35/45	35/45	35/45			
RACA14060ACT151AA	A15C	1	10.8/14.4	36.85/49.13	30.1/34.7	48/53	50/50	60/60	38/44	40/45	32/32	35/45	35/45	35/45			



Air

Electric Heater Kits
RACA15 Series

208/240 VOLT, SINGLE PHASE, 60 Hz, AUXILIARY ELECTRIC HEATER KITS CHARACTERISTICS AND APPLICATION														
Single Power Supply for Both Unit and Heater Kit						Separate Power Supply for Both Unit and Heater Kit								
Model No.	RXQJ-Heater Kit Nominal kW	No. of Sequence Steps	Heater Kit			Air Conditioner			Heater Kit			Air Conditioner		
			Rated Heater kW @ 208/240V	Heater kBTU/Hr @ 208/240V	Heater Amp @ 208/240V	Unit Min. Ampacity @ 208/240V	Over Current Protective Device Size Min./Max. @ 208V	Min. Ckt. Ampacity 208/240V	Max. Fuse Size 208/240V	Min. Circuit Ampacity 208/240V	Over Current Protective Device Size Min./Max. @ 240V	Min. Ckt. Ampacity 208/240V	Max. Fuse Size 208/240V	Over Current Protective Device Size Min./Max. @ 208V
RACA15024AJT000AA	No Heat	—	—	—	—	19/19	20/25	20/25	—	—	—	19/19	20/25	20/25
RACA15024AJT051AA	A05J	1	3.6/4.8	12.28/16.38	17.3/20.0	26/29	30/30	30/30	22/25	25/25	25/25	19/19	20/25	20/25
RACA15024AJT101AA	A10J	1	7.2/9.6	24.57/32.76	34.6/40.0	47/54	50/50	60/60	44/50	45/50	45/50	19/19	20/25	20/25
RACA15030AJT000AA	No Heat	—	—	—	—	21/21	25/30	25/30	—	—	—	21/21	25/30	25/30
RACA15030AJT051AA	A05J	1	3.6/4.8	12.28/16.38	17.3/20.0	26/29	30/30	30/30	22/25	25/25	25/25	21/21	25/30	25/30
RACA15030AJT101AA	A10J	1	7.2/9.6	24.57/32.76	34.6/40.0	47/54	50/50	60/60	44/50	45/50	45/50	21/21	25/30	25/30
RACA15036AJT000AA	No Heat	—	—	—	—	24/24	25/35	25/35	—	—	—	24/24	25/35	25/35
RACA15036AJT051AA	A05J	1	3.6/4.8	12.28/16.38	17.3/20.0	27/31	30/35	35/35	22/25	25/25	25/25	24/24	25/35	25/35
RACA15036AJT101AA	A10J	1	7.2/9.6	24.57/32.76	34.6/40.0	49/56	50/50	60/60	44/50	45/50	45/50	24/24	25/35	25/35
RACA15048AJT151AA	A15J	1	10.8/14.4	36.85/49.13	51.9/60.0	70/81	70/70	90/90	65/75	70/80	70/80	24/24	25/35	25/35
RACA15042AJT000AA	No Heat	—	—	—	—	30/30	30/45	30/45	—	—	—	30/30	30/45	30/45
RACA15042AJT051AA	A05J	1	3.6/4.8	12.28/16.38	17.3/20.0	30/33	30/45	35/45	22/25	25/25	25/25	30/30	30/45	30/45
RACA15042AJT101AA	B10J	1	7.2/9.6	24.57/32.76	34.6/40.0	51/58	60/60	60/60	44/50	45/50	45/50	30/30	30/45	30/45
RACA15042AJT151AA	B15J	1	10.8/14.4	36.85/49.13	51.9/60.0	73/83	80/80	90/90	65/75	70/80	70/80	30/30	30/45	30/45
RACA15048AJT000AA	No Heat	—	—	—	—	33/33	35/50	35/50	—	—	—	33/33	35/50	35/50
RACA15048AJT051AA	A05J	1	3.6/4.8	12.28/16.38	17.3/20.0	33/33	35/50	35/50	22/25	25/25	25/25	33/33	35/50	35/50
RACA15048AJT101AA	B10J	1	7.2/9.6	24.57/32.76	34.6/40.0	51/58	60/60	60/60	44/50	45/50	45/50	33/33	35/50	35/50
RACA15048AJT151AA	B15J	1	10.8/14.4	36.85/49.13	51.9/60.0	73/83	80/80	90/90	65/75	70/80	70/80	33/33	35/50	35/50
RACA15060AJT000AA	No Heat	—	—	—	—	46/46	50/70	50/70	—	—	—	46/46	50/70	50/70
RACA15060AJT051AA	A05J	1	3.6/4.8	12.28/16.38	17.3/20.0	46/46	50/70	50/70	22/25	25/25	25/25	46/46	50/70	50/70
RACA15060AJT101AA	B10J	1	7.2/9.6	24.57/32.76	34.6/40.0	53/60	60/70	60/70	44/50	45/50	45/50	46/46	50/70	50/70
RACA15060AJT151AA	B15J	1	10.8/14.4	36.85/49.13	51.9/60.0	75/85	80/80	90/90	65/75	70/80	70/80	46/46	50/70	50/70
RACA15036ACT000AA	No Heat	—	—	—	—	17/17	20/25	20/25	—	—	—	17/17	20/25	20/25
RACA15036ACT101AA	A10C	1	7.2/9.6	24.57/32.76	20.0/23.1	31/34	35/35	35/35	25/29	25/30	25/30	17/17	20/25	20/25
RACA15036ACT151AA	A15C	1	10.8/14.4	36.85/49.13	30.1/34.7	43/49	45/45	50/50	38/44	40/45	40/45	17/17	20/25	20/25
RACA15042ACT000AA	No Heat	—	—	—	—	24/24	25/35	25/35	—	—	—	24/24	25/35	25/35
RACA15042ACT101AA	A10C	1	7.2/9.6	24.57/32.76	20.0/23.1	33/37	35/35	40/40	25/29	25/30	25/30	24/24	25/35	25/35
RACA15042ACT151AA	A15C	1	10.8/14.4	36.85/49.13	30.1/34.7	46/51	50/50	60/60	38/44	40/45	40/45	24/24	25/35	25/35
RACA15048ACT000AA	No Heat	—	—	—	—	25/25	25/35	25/35	—	—	—	25/25	25/35	25/35
RACA15048ACT101AA	A10C	1	7.2/9.6	24.57/32.76	20.0/23.1	33/37	35/35	40/40	25/29	25/30	25/30	25/25	25/35	25/35
RACA15048ACT151AA	A15C	1	10.8/14.4	36.85/49.13	30.1/34.7	46/51	50/50	60/60	38/44	40/45	40/45	25/25	25/35	25/35
RACA15060ACT000AA	No Heat	—	—	—	—	30/30	50/45	50/45	—	—	—	30/30	50/45	50/45
RACA15060ACT101AA	A10C	1	7.2/9.6	24.57/32.76	20.0/23.1	35/39	50/50	50/50	25/29	25/30	25/30	30/30	50/45	50/45
RACA15060ACT151AA	A15C	1	10.8/14.4	36.85/49.13	30.1/34.7	48/53	50/50	60/60	38/44	40/45	40/45	30/30	50/45	50/45



INTEGRATED AIR & WATER

UNIT DIMENSIONS PACKAGE AIR CONDITIONERS

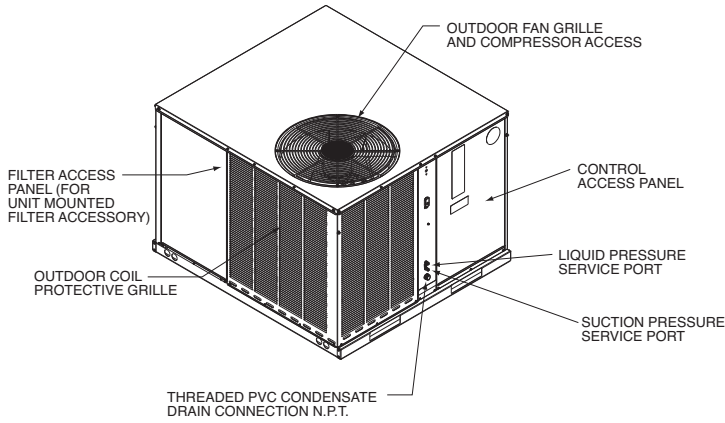

IMPORTANT: UNIT MUST BE LEVEL TO PREVENT WATER MIGRATION

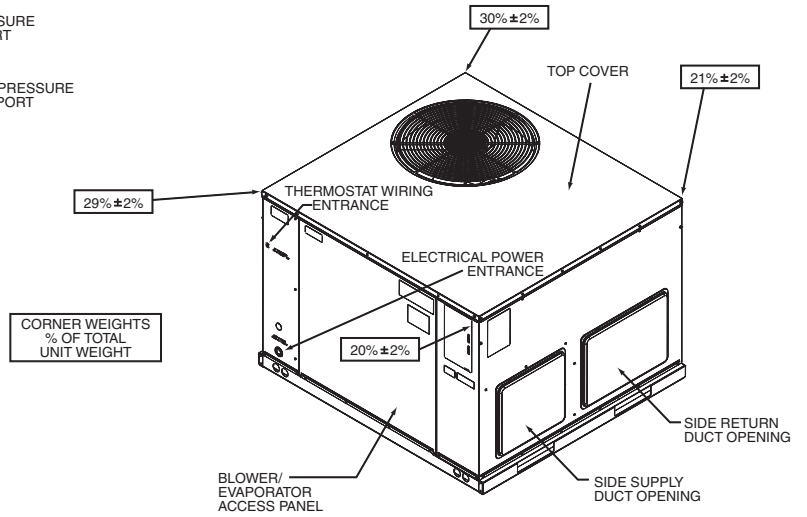

TOP VIEW

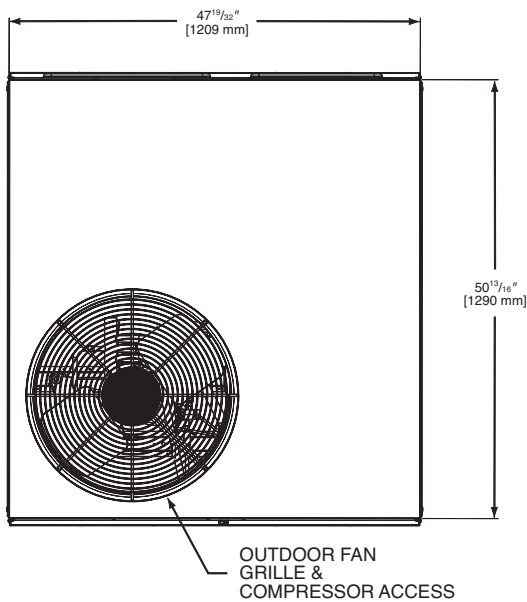

BOTTOM VIEW

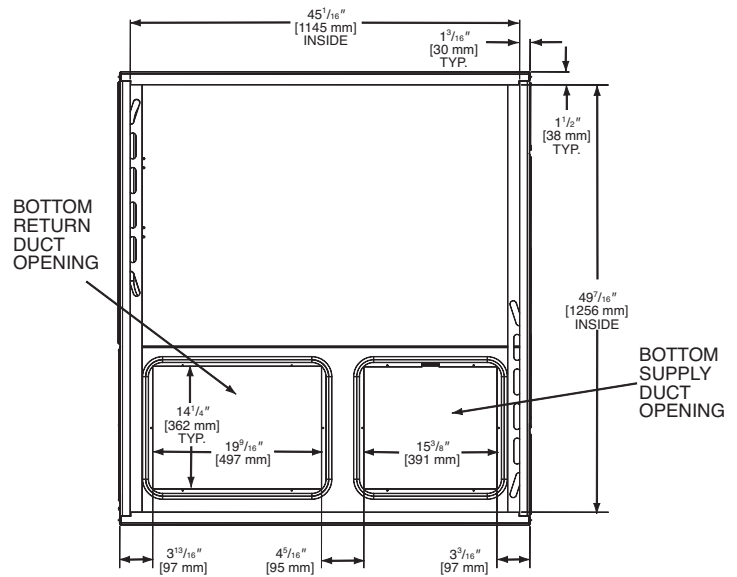

[] Designates Metric Conversions

SIDE VIEW

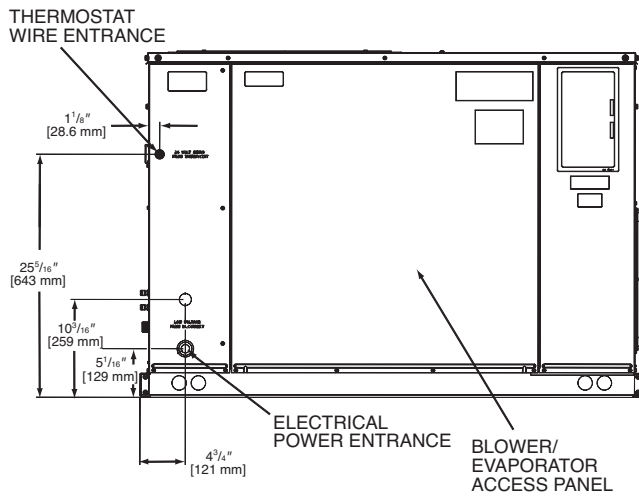

SIDE VIEW

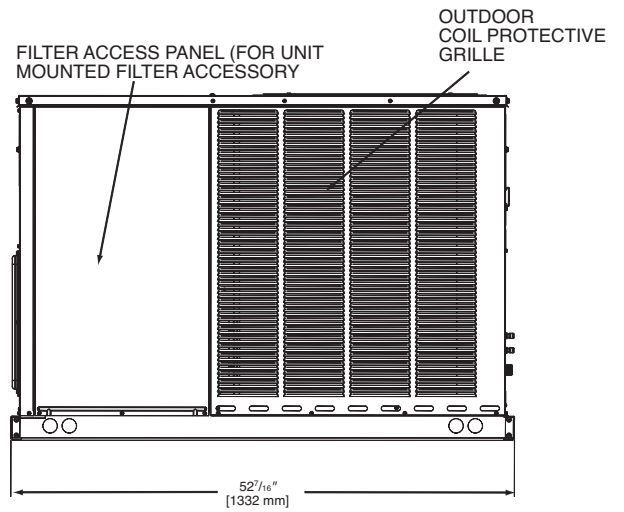

FRONT VIEW

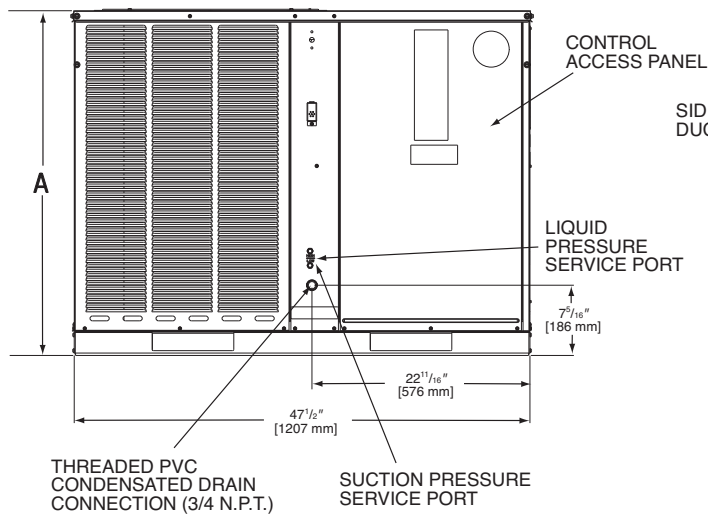

REAR VIEW

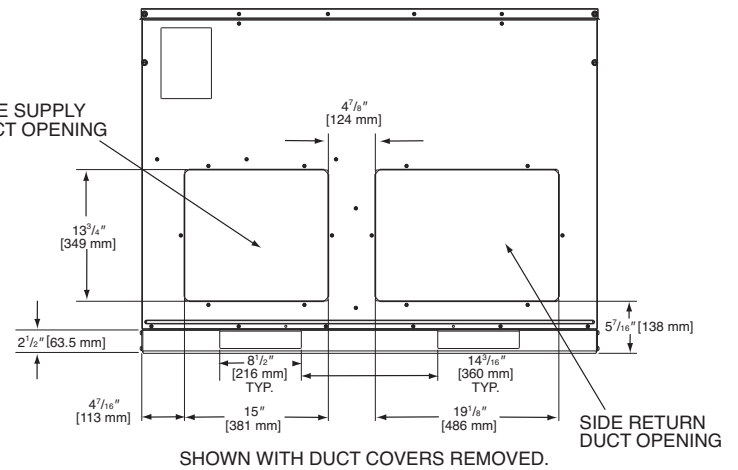

IMPORTANT:
Unit must be level to prevent water migration.

Model #	Height "A"
024, 030, 036, 042	35 ¹⁵ / ₁₆
048, 060	41

[] Designates Metric Conversions

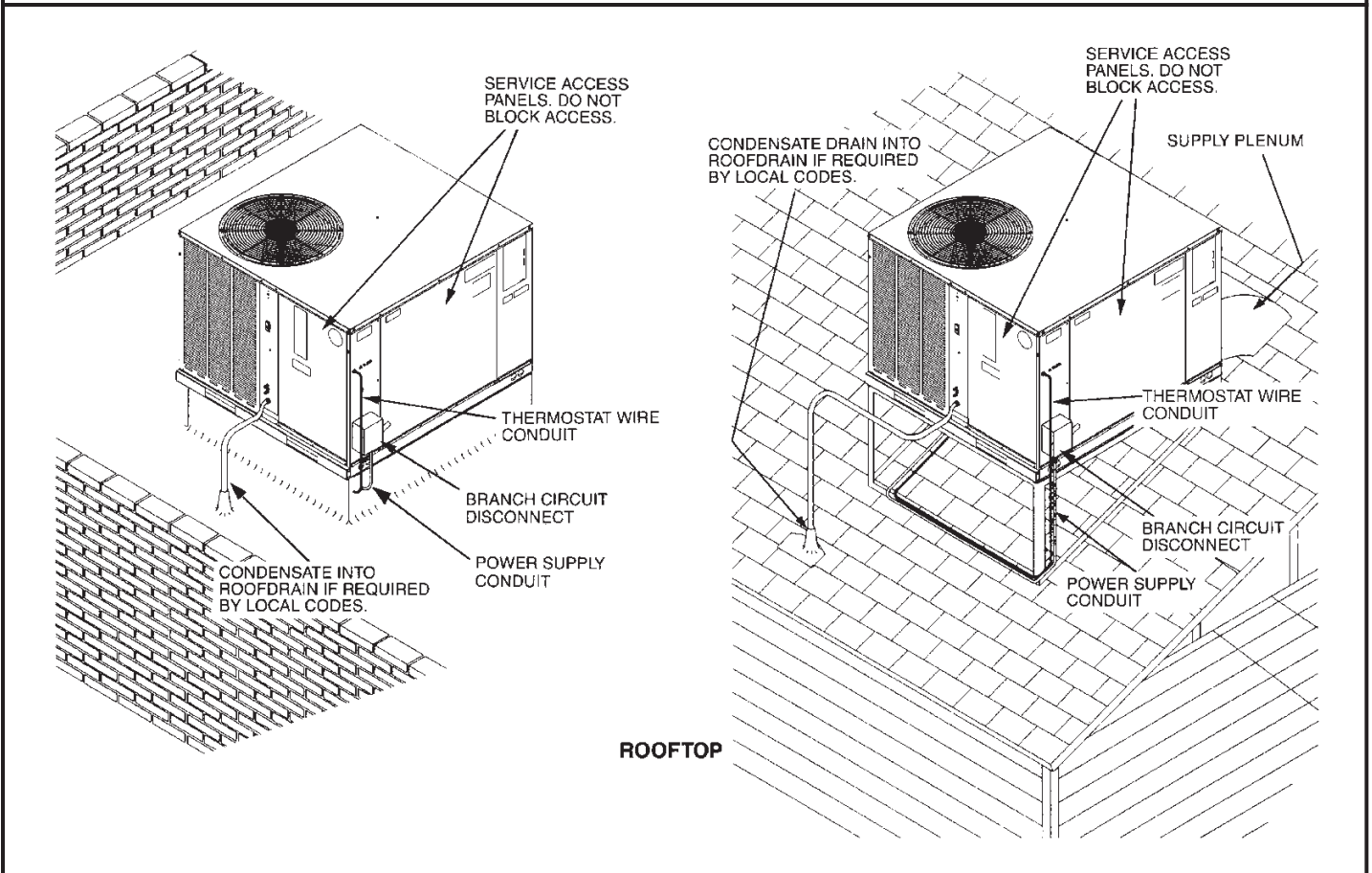
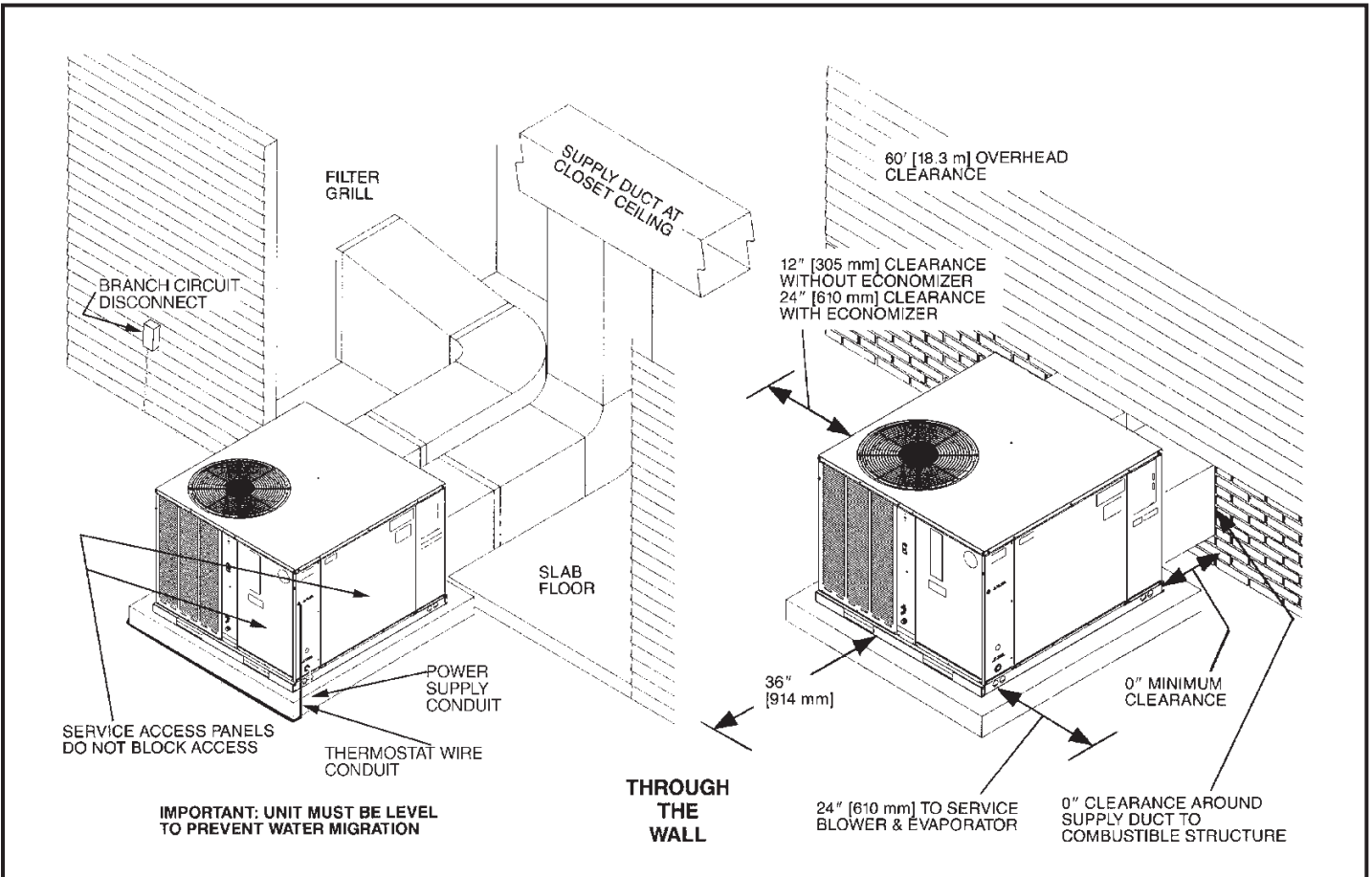

[] Designates Metric Conversions

ACCESSORY EQUIPMENT

Accessory Description	Model Application	Accessory Model No.
Roofcurbs	RACA14/15	RXSG-AAA08 (8" [203 mm] Height) RXSG-AAA14 (14" [356 mm] Height) RXSG-AAA24 (24" [610 mm] Height)
Supply & Return Diffusers	RACA14/15	RXRN-BD15
Economizers (Convertible)	RACA14/15	AXRD-01RACAM3
Fresh Air Damper	RACA14/15	AXRF-FAB1 (Motorized-35%) AXRF-FAA1 (Fixed-35%)
Rectangular to Round Transition (Downflow)	RACA14/15	RXMC-CA02 (16" [406 mm] Ducts) RXMC-CA03 (18" [457 mm] Ducts)
Filter Kit	RACA14/15	RXRY-B01
Sideflow Rectangular to Round Transition	RACA14/15	AXMC-BA01
Low Ambient Control	RACA14/15	RXRZ-B01
High Pressure Control ①	RACA14/15	RXAB-E01
Low Pressure Control ②	RACA14/15	RXAC-C01

① High pressure switch standard on RACA (13/14/15) 060
 ② Low pressure switch standard on RACA 15 060.

[] Designates Metric Conversions

COMMON SUPPLY/RETURN CONCENTRIC AIR DIFFUSER

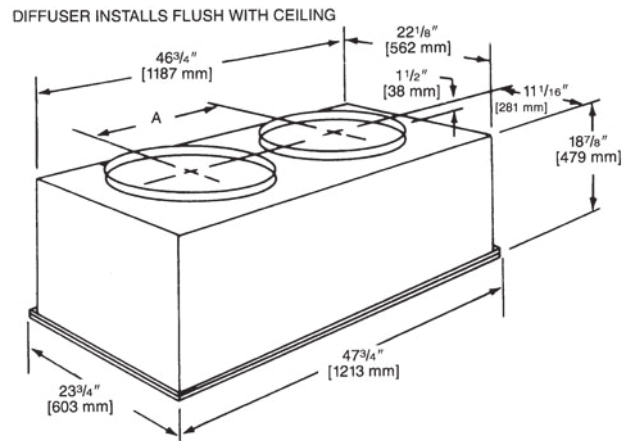
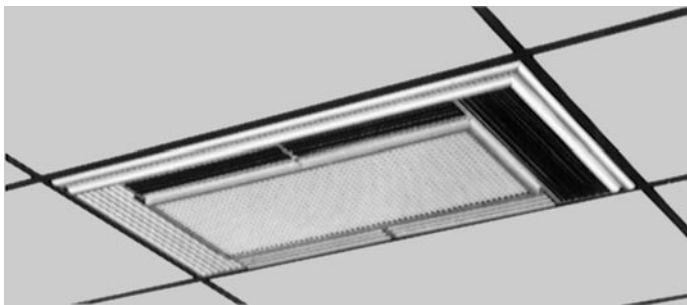

NOTE: The location of the combination supply and return diffuser should not exceed 10 feet [3.05 m] above the floor level for units @ 1000 CFM [472 L/s] or less and 12 [3.66 m] to 14 feet [4.27 m] above the floor level for units with CFM greater than 1000 [472 L/s]. If the diffuser is installed with a greater distance than recommended above, the supply air may become stratified above the required comfort area causing uncomfortable conditions.

SUPPLY/RETURN DIFFUSER

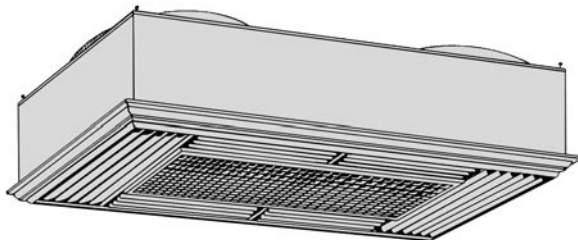

Designed to convert a side by side or an over and under arrangement into a concentric distribution of air. The diffuser is flush mounted, completely insulated, assembled, and internally baffled to provide four way supply air distribution with a center return. To make the assembly complete and ready to fit into a 2' [0.61 m] x 4' [1.22 m] suspended ceiling grid, the diffuser includes adjustable supply louvers, hanging rings, anti-sweat gasket, and round flanges for use with flexible ducts.

Model No.	Diameter Inches [mm]	Shipping Wt. Lbs. [kg]	Dimension A Inches [mm]
RXRN-BD15	16 [406]	90 [40.82]	20 1/2 [521]

AIRFLOW/PRESSURE DROP INFORMATION (INCHES W.C. [kPa])

Accessory	Approximate CFM [L/s]-Supply Air			
	1300 [614]	1575 [743]	1800 [850]	2200 [1038]
Plenum & Supply/Return Duct	.07 [.017]	.10 [.024]	.12 [.030]	.17 [.042]
Diffuser	.09 [.022]	.13 [.032]	.16 [.040]	.24 [.060]
Economizer	.06 [.015]	.09 [.022]	.11 [.027]	.17 [.042]

SUPPLY AIR/PERFORMANCE

Diffuser Airflow CFM [L/s]	Range of Throw Ft. [m]
800 [378]-1200 [566]	14 [4.27]-16 [4.88]
1600 [755]-2000 [944]	18 [5.49]-28 [8.53]

FILTER KIT INSTALLATION

RXRY-B01

For use in either vertical or horizontal discharge.

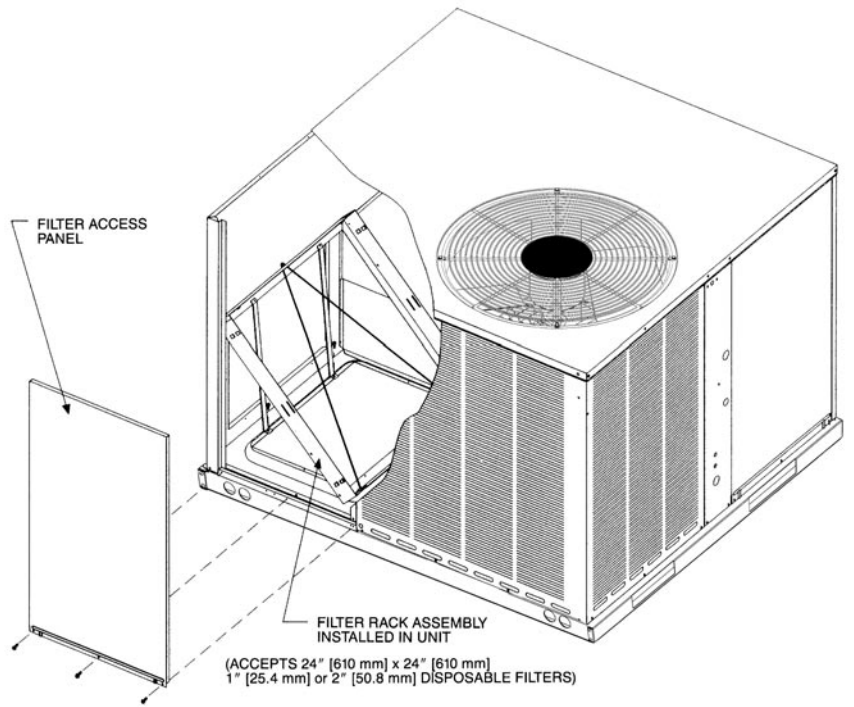

Airflow Pressure Drop, Inches W.C. [kPa]		
CFM [L/s]	1" Filter	2" Filter
500 [236]	.02 [.0050]	.03 [.0075]
600 [283]	.02 [.0050]	.03 [.0075]
700 [330]	.03 [.0075]	.04 [.0101]
800 [378]	.04 [.0101]	.05 [.0124]
900 [425]	.05 [.0124]	.06 [.0149]
1000 [472]	.07 [.0174]	.08 [.0199]
1100 [519]	.08 [.0199]	.09 [.0224]
1200 [566]	.10 [.0249]	.12 [.0299]
1300 [614]	.13 [.0324]	.15 [.0373]
1400 [661]	.16 [.0398]	.19 [.0473]
1500 [708]	.19 [.0473]	.21 [.0523]
1600 [755]	.20 [.0498]	.23 [.0572]
1700 [802]	.21 [.0523]	.24 [.0598]
1800 [850]	.22 [.0548]	.25 [.0623]
1900 [897]	.24 [.0598]	.27 [.0672]
2000 [944]	.26 [.0647]	.29 [.0722]

[] Designates Metric Conversions

DUCT ADAPTERS RECTANGULAR TO ROUND TRANSITIONS (DOWNFLOW)

RXMC-CA02

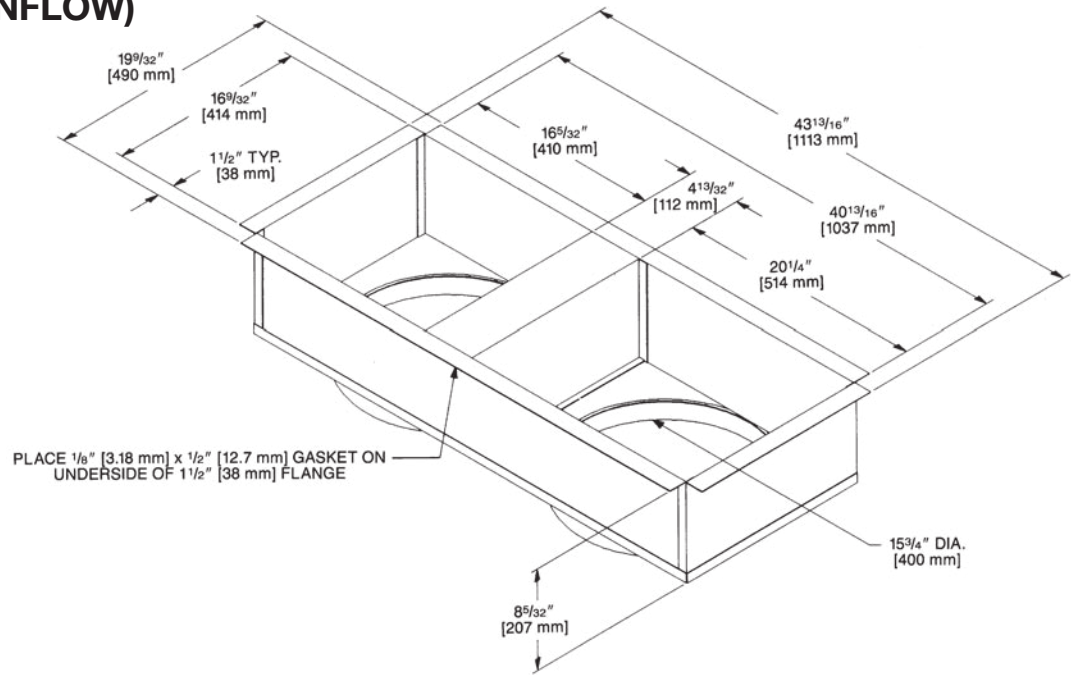

RXMC-CA03

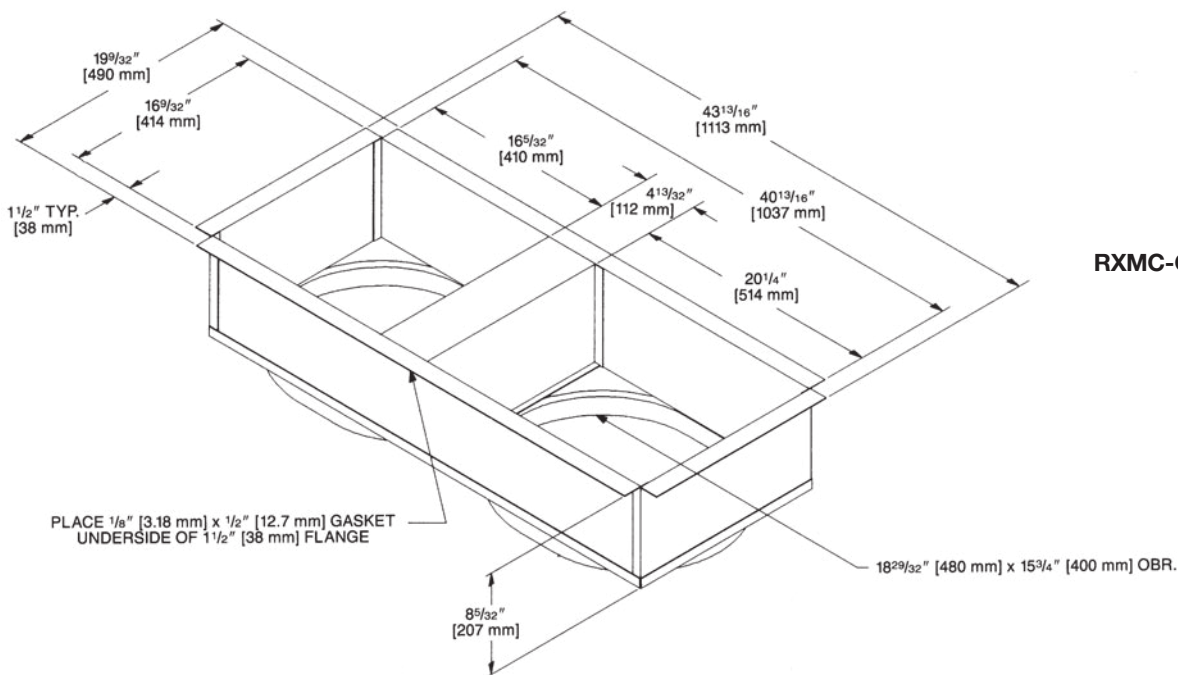

[] Designates Metric Conversions

FRESH AIR DAMPER FOR USE ON RACA14- SERIES

AXRF-FAA1 (Fixed - 0-35%)

The 0-35% manual outside Air Damper is designed to replace the unit return air duct cover. No drilling or damper assembly is required. The amount of outside air (0-35%) is controlled by simply adjusting the side damper.

AXRF-FAB1 (Motorized - 0-35%)

The 0-35% motorized outside Air Damper is designed to replace the unit return air duct cover. No drilling or damper assembly is required. The control motor opens the adjustable slide damper when the unit blower motor is energized.

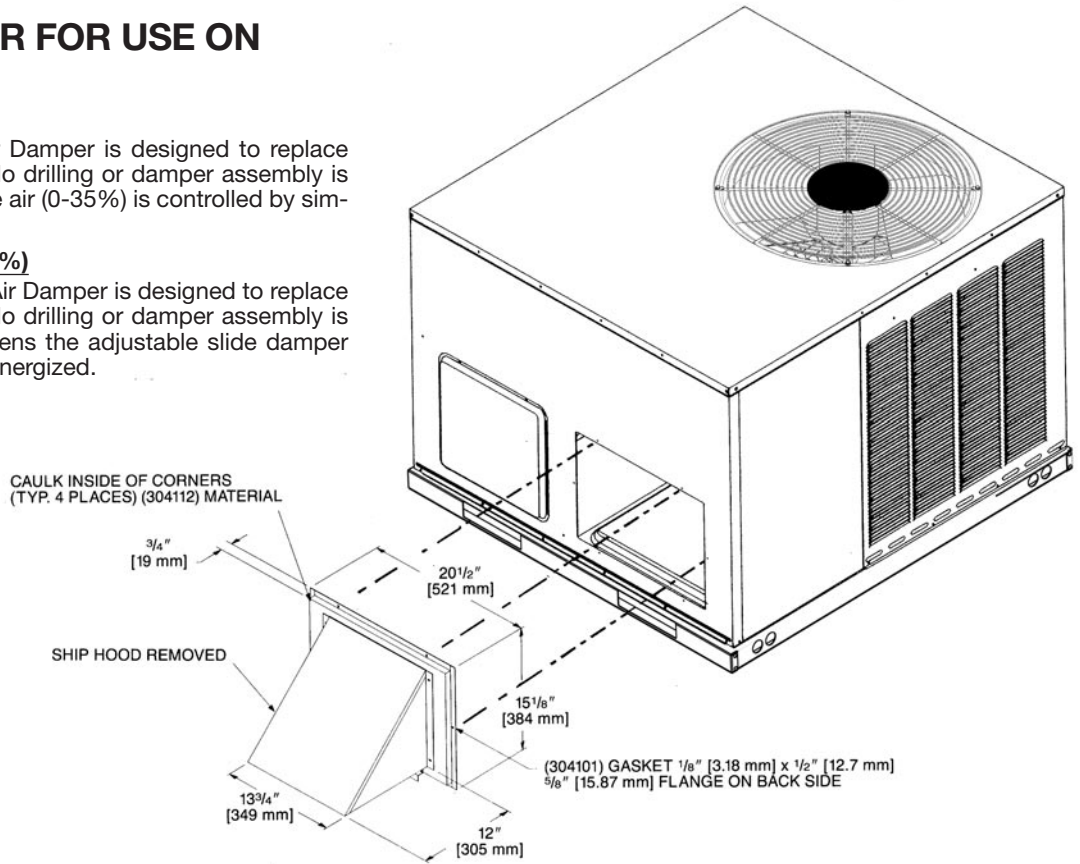

[] Designates Metric Conversions

DUCT ADAPTER SIDEFLOW SQUARE TO ROUND TRANSITION AXMC-BA01

Adapts the side rectangular supply and return openings to 14" [356 mm] diameter round openings. Adapters provided with same finish as unit and also provided with thermal insulation.

[] Designates Metric Conversions

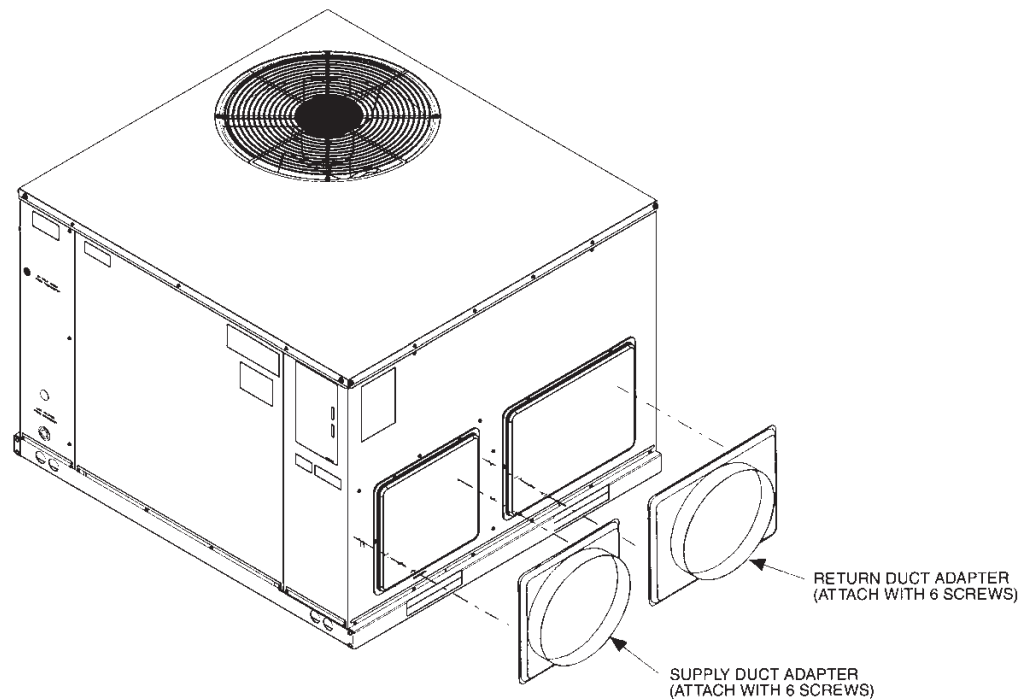

ROOFCURB (Full Perimeter)

RXSG-AAA08, RXSG-AAA14 and RXSG-AAA24 for RACA- Series

Hinged corners make for fast, easy set-up.

RXSG-AAA08
(8" [203 mm] High)

NOT for use with
RQKA/RQLA/RQMA
Package Heat Pumps.

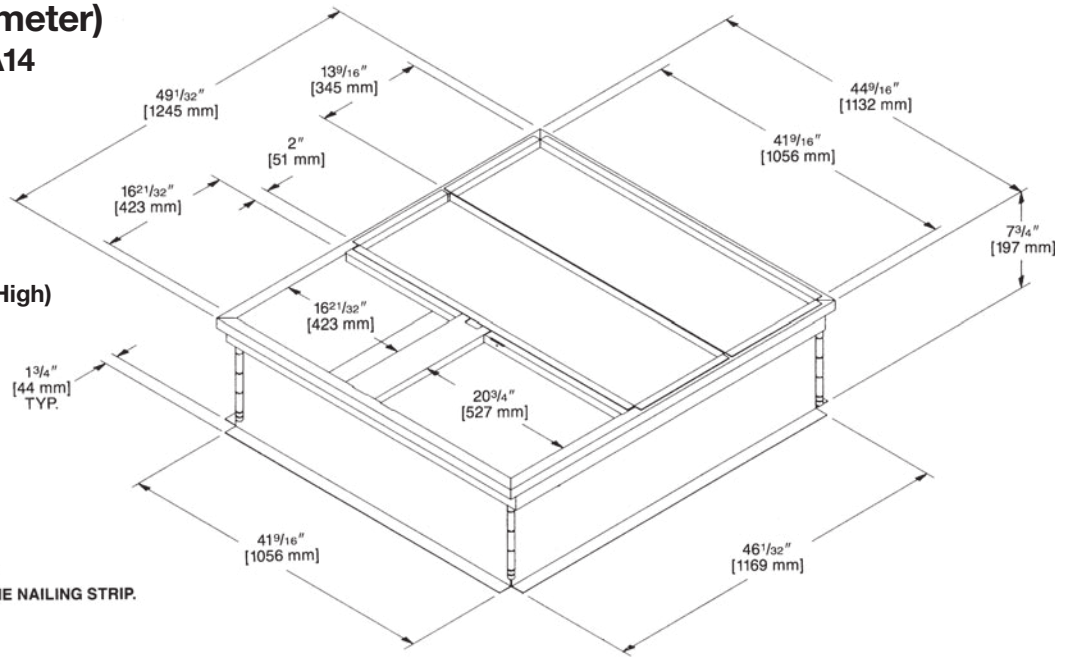

NOTE: PERIMETER OF ROOFCURB IS SUPPLIED WITH A NOMINAL 1" [25.4 mm] x 4" [102 mm] PINE NAILING STRIP.

RXSG-AAA14
(14" [356 mm] High)

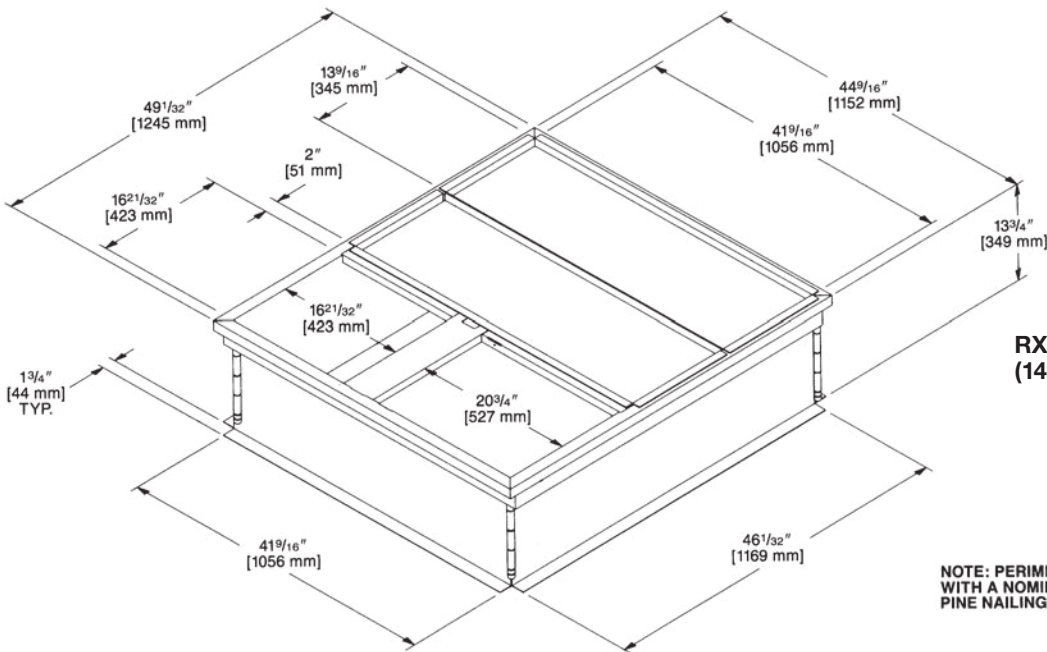

NOTE: PERIMETER OF ROOFCURB IS SUPPLIED WITH A NOMINAL 1" [25.4 mm] x 4" [102 mm] PINE NAILING STRIP.

[] Designates Metric Conversions

ROOFCURB (Full Perimeter) (Cont.)

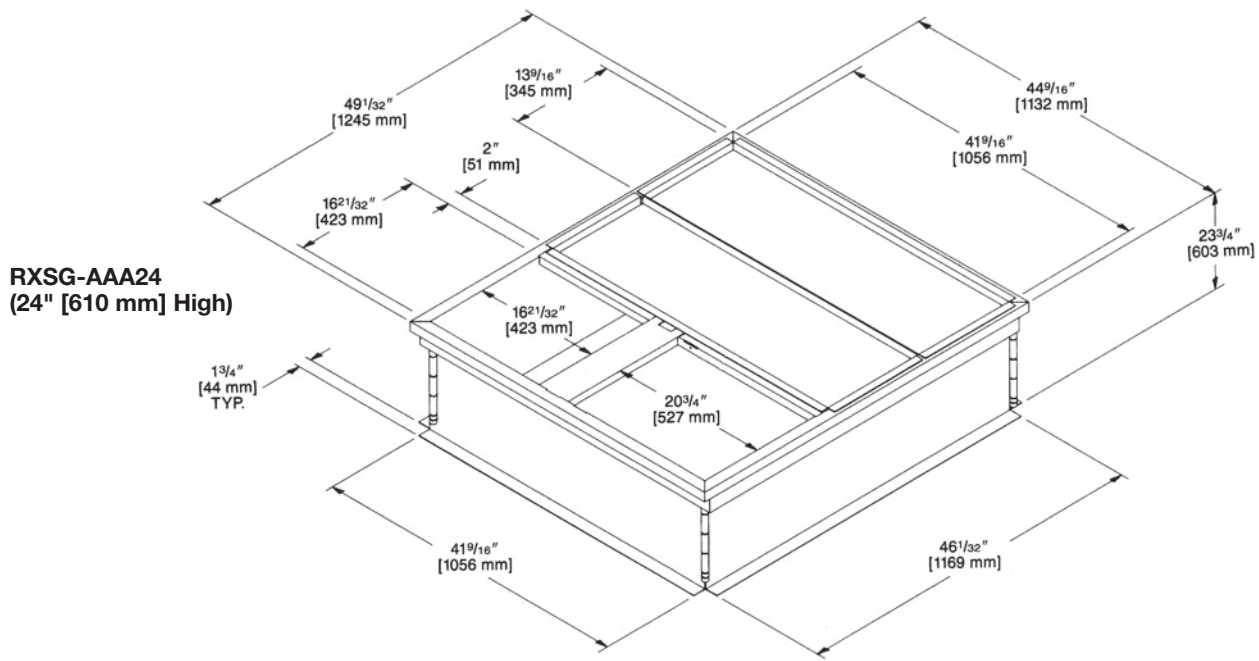

[] Designates Metric Conversions

PACKAGE AIR CONDITIONERS & GAS/ELECTRIC PACKAGE UNITS ROOFCURB INSTALLATION (Full Perimeter)

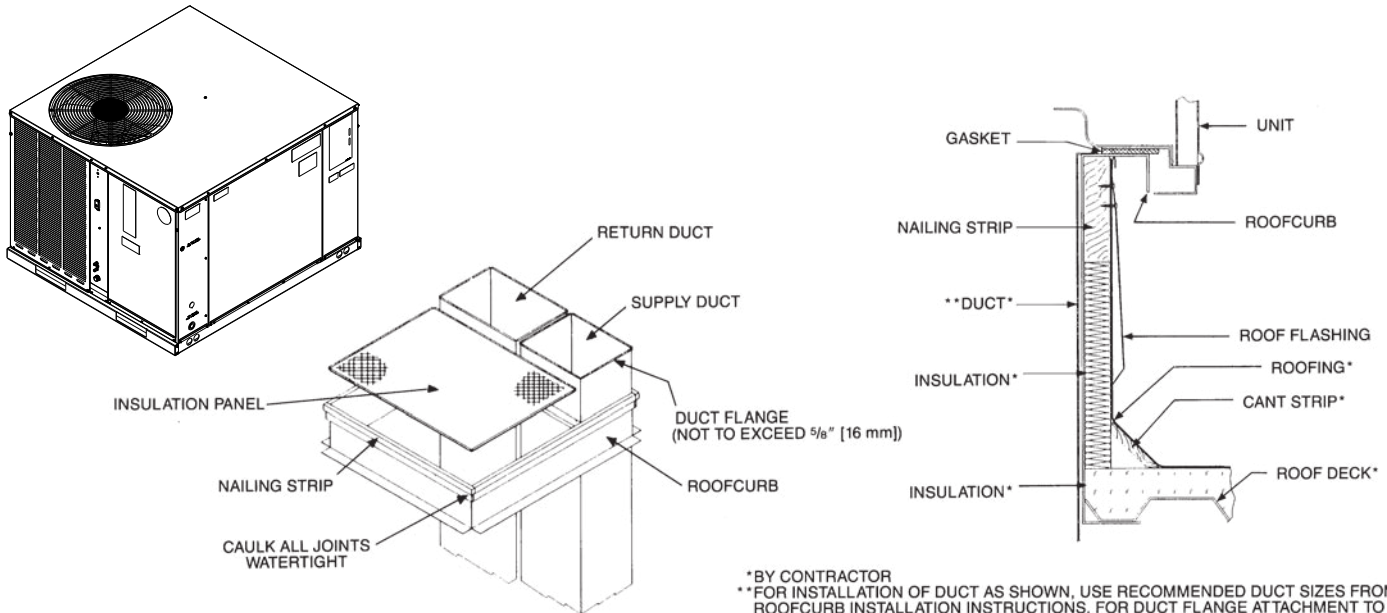

* BY CONTRACTOR
** FOR INSTALLATION OF DUCT AS SHOWN, USE RECOMMENDED DUCT SIZES FROM ROOFCURB INSTALLATION INSTRUCTIONS. FOR DUCT FLANGE ATTACHMENT TO UNIT, SEE UNIT INSTALLATION INSTRUCTIONS FOR RECOMMENDED DUCT SIZES.

[] Designates Metric Conversions

ROOFCURB ADAPTERS

Fabricated from galvanized steel to adapt the New cabinet to the old style curb. All are furnished with a New gasket.

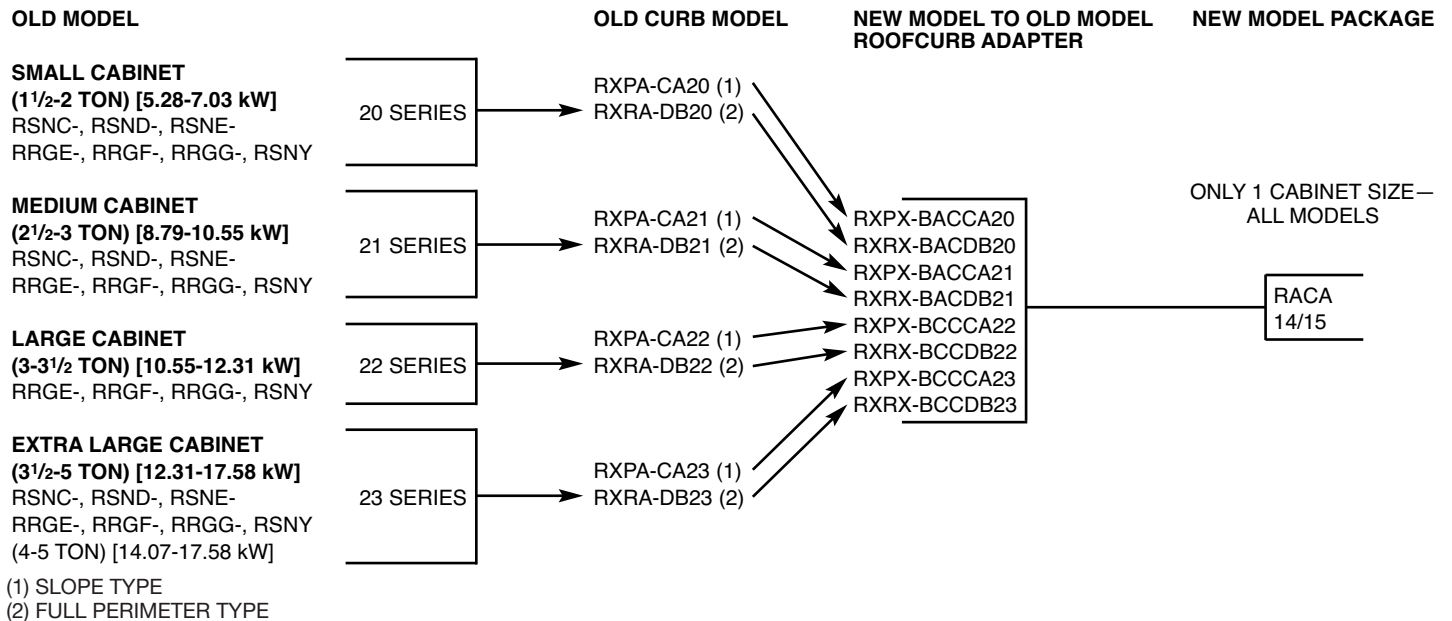

ELECTRIC HEATER KITS—RACA14/15-

Unit Model Application	Electric Heater Kit Models
RACA (14/15) (024/030) AJ	RXQJ-A05J (208-240 volt, 1-ph, 5kW)
	RXQJ-A10J (208-240 volt, 1-ph, 10kW)
RACA (14/15) (036/042/048/060) AJ	RXQJ-A05J (208-240 volt, 1-ph, 5kW)
	RXQJ-A10J (208-240 volt, 1-ph, 10kW)
	RXQJ-A15J (208-240 volt, 1-ph, 15kW)
	RXQJ-A05J (208-240 volt, 1-ph, 5kW)
RACA (14/15) (036/042/048/060) AC	RXQJ-A10C (208-240 volt, 3-ph, 10kW)
	RXQJ-A15C (208-240 volt, 3-ph, 15kW)
	RXQJ-A10C (208-240 volt, 3-ph, 10kW)

WARNING

ONLY ELECTRIC HEATER KITS SUPPLIED BY THIS MANUFACTURER AS DESCRIBED IN THIS PUBLICATION HAVE BEEN DESIGNED, TESTED, AND EVALUATED BY A NATIONALLY RECOGNIZED SAFETY TESTING AGENCY FOR USE WITH THIS UNIT. USE OF ANY OTHER MANUFACTURED ELECTRIC HEATERS INSTALLED WITHIN THIS UNIT MAY CAUSE HAZARDOUS CONDITIONS RESULTING IN PROPERTY DAMAGE, FIRE, BODILY INJURY OR DEATH.

BEFORE PURCHASING THIS APPLIANCE, READ IMPORTANT ENERGY COST AND EFFICIENCY INFORMATION AVAILABLE FROM YOUR RETAILER.

GENERAL TERMS OF LIMITED WARRANTY*

Rheem will furnish a replacement for any part of this product which fails in normal use and service within the applicable periods stated, in accordance with the terms of the limited warranty.

***For complete details of the Limited and Conditional Warranties, including applicable terms and conditions, contact your local contractor or the Manufacturer for a copy of the product warranty certificate.**

Conditional Parts (Registration Required)

1 Phase, Residential Applications.....Ten (10) Years

Compressor

1 Phase, Residential Applications.....Ten (10) Years

1 & 3 Phase, Commercial Applications.....Five (5) Years

Parts

1 & 3 Phase, Commercial ApplicationsOne (1) Year



The new degree of comfort.™

In keeping with its policy of continuous progress and product improvement, Rheem reserves the right to make changes without notice.

Rheem Heating, Cooling & Water Heating • 5600 Old Greenwood Road
Fort Smith, Arkansas 72908 • www.rheem.com

Rheem Canada Ltd./Ltée • 125 Edgeware Road, Unit 1
Brampton, Ontario • L6Y 0P5



INTEGRATED HOME COMFORT

PRINTED IN U.S.A. 8/19 QG FORM NO. S11-969 REV. 4