



Air

Package Air Conditioner  
RACA14/15 Series

The new degree of comfort.™

## Rheem *Commercial Classic*® Series Package Air Conditioner



### **RACA14- 14 SEER Series**

Nominal Sizes 2-5 Tons [7.0-17.6 kW]

### **RACA15- 15 SEER Series**

Nominal Sizes 2-5 Tons [7.0-17.6 kW]



(15 SEER/12.0 EER  
AND ABOVE ONLY)

*"Proper sizing and installation of equipment is critical to achieve optimal performance. Ask your Contractor for details or visit [www.energystar.gov](http://www.energystar.gov)."*



INTEGRATED AIR & WATER

## TABLE OF CONTENTS

Unit Features & Benefits .....	3-4
Model Number Identification .....	5
General Data	
RACA14- Series .....	6-9
RACA15- Series .....	10-11
General Data Notes .....	12
Gross Systems Performance Data	
RACA14- Series .....	13-18
RACA15- Series .....	19-24
Indoor Airflow Performance .....	25-34
Electrical Data	
RACA14- Series .....	35-36
RACA15- Series .....	37-38
Electric Heater Kits .....	39-40
Dimensional Data .....	41-42
Typical Installations .....	43
Accessories .....	44-53
Wiring Diagrams .....	54-59
Limited Warranty .....	60

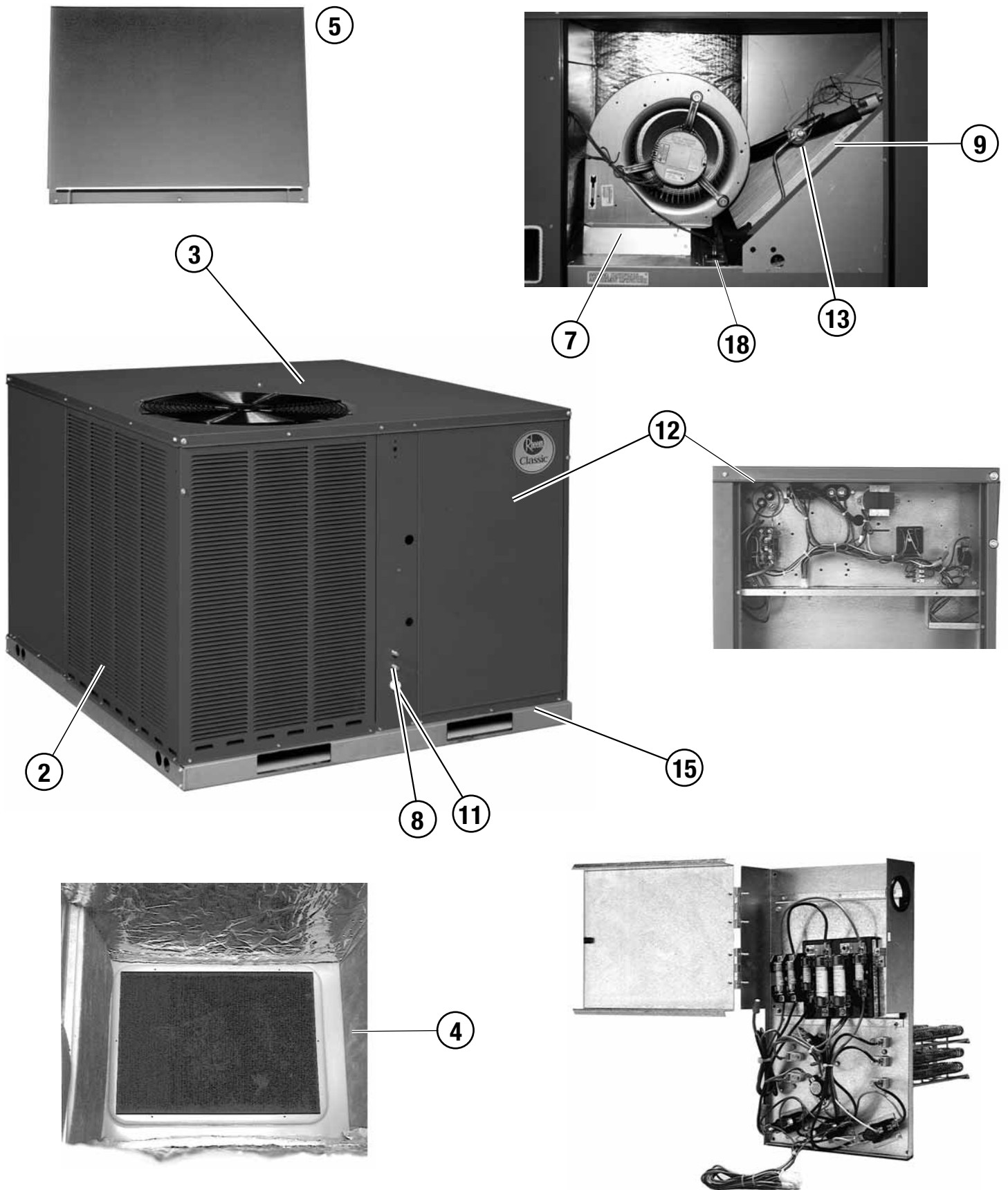



## Features Below Correspond to Photos on Page 3

1. All models feature Scroll® compressors for maximum efficiency and quiet operation. The 5-Ton RACA15 model features Scroll UltraTech™ 2-Stage compressors with Comfort Alert™ diagnostics (see below), high/low pressure switches, and hard start kit.
2. Louvered condenser compartment to protect the coil against yard hazards and/or weather extremes.
3. One-piece top with a drip lip to help keep water off of the unit sides.
4. Drawn supply and return air openings feature a one-inch tall flange to prevent water migration into the ductwork.
5. Access panels have “weep holes” and channels to further help manage water run-off.
6. Side and down discharge options available on all models.
7. Easily accessible blower section complete with slide-out blower.
8. Externally mounted refrigerant connections are conveniently located for easy service diagnostics.
9. Micro Channel evaporator and condenser delivers superior performance with less refrigerant charge and less weight than conventional copper tube/aluminum fin coils. In addition the all aluminum construction has superior protection against formicary corrosion and aluminum tube rubbing potential. Its easier to clean and has a more robust surface.
10. Supplemental electric heat strips up to 15 kW are available (field or factory installed) for periods of extreme cold temperatures. Single point wiring simplifies installation.
11. All units feature an internal trap on the condensate line eliminating the need for installing an on-site external trap.
12. Easily accessible control box.
13. Thermal expansion valve standard on all models for superior superheat control, reliability, and energy efficiency at all operating conditions.
14. Solid core liquid line. Filter drier standard on all models (not shown).
15. Rugged baserail included for improved installation and handling.
16. Molded compressor plug.
17. Complete factory charged, wired and run tested.
18. A double sloped evaporator coil drain pan assures all water is removed from the unit to improve indoor air quality.

## Comfort Alert™ Diagnostics – Faster Service And Improved Accuracy (5 Ton RACA15 2-Stage Model Only)

The Comfort Alert™ diagnostics module is a breakthrough innovation for troubleshooting air conditioning system failures. The module is installed in the control box near the compressor contactor. By monitoring and analyzing data from the Scroll® compressor and the thermostat demand, the module can accurately detect the cause of electrical and system related failures without any sensors. A flashing LED indicator communicates the ALERT code and guides the service technician more quickly and accurately to the root cause of a problem.

**NOTE: Single phase module does not provide safety protection! The Comfort Alert module is a monitoring device and cannot control or shut down the compressor unless used with a compatible thermostat.**

**NOTE: Three phase module provides compressor protection and will shut down the compressor when compressor damaging conditions are detected.**



**R AC A 14 036 A J D 10 1 A A X X X**

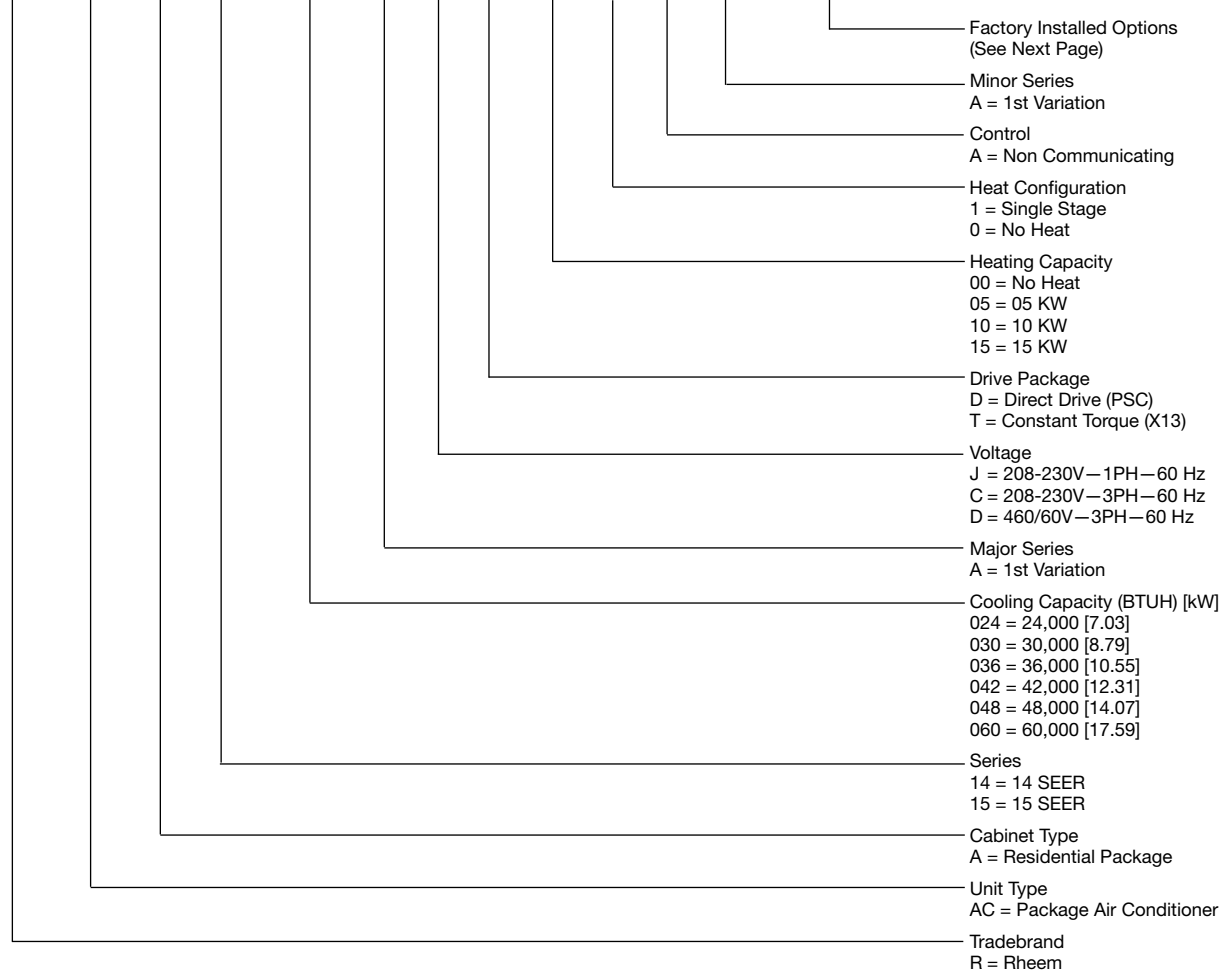

[ ] Designates Metric Conversions

## NOMINAL SIZES 2-5 TONS [7.0-17.6 kW]

Model RACA14 Series	024AJD***AA	030AJD***AA	036ACD***AA	036AJD***AA
<b>Cooling Performance<sup>1</sup></b>				<b>CONTINUED</b> 
Gross Cooling Capacity Btu [kW]	24,800 [7.27]	30,200 [8.85]	35,400 [10.37]	35,400 [10.37]
EER/SEER <sup>2</sup>	11.6/14	12/14	11.8/14	11.8/14
Nominal CFM/AHRI Rated CFM [L/s]	800/900 [378/425]	1000/1000 [472/472]	1200/1200 [566/566]	1200/1200 [566/566]
AHRI Net Cooling Capacity Btu [kW]	24,000 [7.03]	29,000 [8.5]	34,000 [9.96]	34,000 [9.96]
Net Sensible Capacity Btu [kW]	18,400 [5.39]	21,300 [6.24]	24,200 [7.09]	24,200 [7.09]
Net Latent Capacity Btu [kW]	5,600 [1.64]	7,700 [2.26]	9,800 [2.87]	9,800 [2.87]
Net System Power kW	2.07	2.37	2.89	2.89
<b>Compressor</b>				
No./Type	1/Scroll	1/Scroll	1/Scroll	1/Scroll
<b>Outdoor Sound Rating (dB)<sup>3</sup></b>	76	76	76	76
<b>Outdoor Coil—Fin Type</b>	Louvered	Louvered	Louvered	Louvered
Tube Type	MicroChannel	MicroChannel	MicroChannel	MicroChannel
MicroChannel Depth in. [mm]	0.71 [18]	0.71 [18]	0.71 [18]	0.71 [18]
Face Area sq. ft. [sq. m]	7.1 [0.66]	9.9 [0.92]	9.8 [0.91]	9.8 [0.91]
Rows / FPI [FPcm]	1 / 23 [9]	1 / 23 [9]	1 / 23 [9]	1 / 23 [9]
<b>Indoor Coil—Fin Type</b>	Louvered	Louvered	Louvered	Louvered
Tube Type	MicroChannel	MicroChannel	MicroChannel	MicroChannel
MicroChannel Depth in. [mm]	1 [25.4]	1 [25.4]	1 [25.4]	1 [25.4]
Face Area sq. ft. [sq. m]	3.6 [0.33]	3.6 [0.33]	3.6 [0.33]	3.6 [0.33]
Rows / FPI [FPcm]	1 / 17 [7]	1 / 23 [9]	1 / 23 [9]	1 / 17 [7]
Refrigerant Control	TX Valves	TX Valves	TX Valves	TX Valves
Drain Connection No./Size in. [mm]	1/0.75 [19.05]	1/0.75 [19.05]	1/0.75 [19.05]	1/0.75 [19.05]
<b>Outdoor Fan—Type</b>	Propeller	Propeller	Propeller	Propeller
No. Used/Diameter in. [mm]	1/22 [558.8]	1/22 [558.8]	1/22 [558.8]	1/22 [558.8]
Drive Type/No. Speeds	Direct/1	Direct/1	Direct/1	Direct/1
CFM [L/s]	2500 [1180]	2500 [1180]	2700 [1274]	2700 [1274]
No. Motors/HP	1 at 1/3 HP	1 at 1/3 HP	1 at 1/3 HP	1 at 1/3 HP
Motor RPM	1075	1075	1075	1075
<b>Indoor Fan—Type</b>	FC Centrifugal	FC Centrifugal	FC Centrifugal	FC Centrifugal
No. Used/Diameter in. [mm]	1/9x7 [229x178]	1/10x9 [254x229]	1/12x9 [305x229]	1/12x9 [305x229]
Drive Type	Direct	Direct	Direct	Direct
No. Speeds	Multiple	Multiple	Multiple	Multiple
No. Motors	1	1	1	1
Motor HP	1/4	1/2	1/2	1/2
Motor RPM	1075	1075	1075	1075
Motor Frame Size	48	48	48	48
<b>Filter—Type</b>	Field Supplied	Field Supplied	Field Supplied	Field Supplied
Furnished	No	No	No	No
(NO.) Size Recommended in. [mm x mm x mm]	(1)1x20x20 [25x508x508]	(1)1x24x24 [25x610x610]	(1)1x24x24 [25x610x610]	(1)1x24x24 [25x610x610]
<b>Refrigerant Charge Oz. [g]</b>	42.7 [1211]	46.8 [1327]	52.7 [1494]	52.7 [1494]
<b>Weights</b>				
Net Weight lbs. [kg]	398 [181]	403 [183]	411 [186]	411 [186]
Ship Weight lbs. [kg]	408 [185]	413 [187]	421 [191]	421 [191]

See Page 12 for Notes.

[ ] Designates Metric Conversions

## NOMINAL SIZES 2-5 TONS [7.0-17.6 kW]

Model RACA14 Series	042ACT***AA	042AJT***AA	048ACT***AA	048AJT***AA
<b>Cooling Performance<sup>1</sup></b>				<b>CONTINUED</b> →
Gross Cooling Capacity Btu [kW]	41,000 [12.01]	41,000 [12.01]	47,500 [13.92]	47,500 [13.92]
EER/SEER <sup>2</sup>	12/14	12/14	11.7/14	11.7/14
Nominal CFM/AHRI Rated CFM [L/s]	1400/1300 [661/613]	1400/1300 [661/613]	1600/1550 [755/731]	1600/1550 [755/731]
AHRI Net Cooling Capacity Btu [kW]	40,000 [11.72]	40,000 [11.72]	46,000 [13.48]	46,000 [13.48]
Net Sensible Capacity Btu [kW]	29,000 [8.5]	29,000 [8.5]	32,500 [9.52]	32,500 [9.52]
Net Latent Capacity Btu [kW]	11,000 [3.22]	11,000 [3.22]	13,500 [3.96]	13,500 [3.96]
Net System Power kW	3.27	3.27	3.89	3.89
<b>Compressor</b>				
No./Type	1/Scroll	1/Scroll	1/Scroll	1/Scroll
<b>Outdoor Sound Rating (dB)<sup>3</sup></b>	76	76	78	78
<b>Outdoor Coil—Fin Type</b>	Louvered	Louvered	Louvered	Louvered
Tube Type	MicroChannel	MicroChannel	MicroChannel	MicroChannel
MicroChannel Depth in. [mm]	0.71 [18]	0.71 [18]	0.71 [18]	0.71 [18]
Face Area sq. ft. [sq. m]	14.1 [1.31]	14.1 [1.31]	16.3 [1.51]	16.3 [1.51]
Rows / FPI [FPcm]	1 / 23 [9]	1 / 23 [9]	1 / 23 [9]	1 / 23 [9]
<b>Indoor Coil—Fin Type</b>	Louvered	Louvered	Louvered	Louvered
Tube Type	MicroChannel	MicroChannel	MicroChannel	MicroChannel
MicroChannel Depth in. [mm]	1 [25.4]	1 [25.4]	1 [25.4]	1 [25.4]
Face Area sq. ft. [sq. m]	3.6 [0.33]	3.6 [0.33]	4.1 [0.38]	4.1 [0.38]
Rows / FPI [FPcm]	1 / 17 [7]	1 / 17 [7]	1 / 20 [8]	1 / 20 [8]
Refrigerant Control	TX Valves	TX Valves	TX Valves	TX Valves
Drain Connection No./Size in. [mm]	1/0.75 [19.05]	1/0.75 [19.05]	1/0.75 [19.05]	1/0.75 [19.05]
<b>Outdoor Fan—Type</b>	Propeller	Propeller	Propeller	Propeller
No. Used/Diameter in. [mm]	1/22 [558.8]	1/22 [558.8]	1/22 [558.8]	1/22 [558.8]
Drive Type/No. Speeds	Direct/1	Direct/1	Direct/1	Direct/1
CFM [L/s]	3500 [1652]	3500 [1652]	3300 [1557]	3300 [1557]
No. Motors/HP	1 at 1/3 HP	1 at 1/3 HP	1 at 1/3 HP	1 at 1/3 HP
Motor RPM	1075	1075	1075	1075
<b>Indoor Fan—Type</b>	FC Centrifugal	FC Centrifugal	FC Centrifugal	FC Centrifugal
No. Used/Diameter in. [mm]	1/12x9 [305x229]	1/12x9 [305x229]	1/12x9 [305x229]	1/12x9 [305x229]
Drive Type	Direct	Direct	Direct	Direct
No. Speeds	Multiple	Multiple	Multiple	Multiple
No. Motors	1	1	1	1
Motor HP	3/4	3/4	3/4	3/4
Motor RPM	1075	1075	1075	1075
Motor Frame Size	48	48	48	48
<b>Filter—Type</b>	Field Supplied	Field Supplied	Field Supplied	Field Supplied
Furnished	No	No	No	No
(NO.) Size Recommended in. [mm x mm x mm]	(1)1x24x24 [25x610x610]	(1)1x24x24 [25x610x610]	(1)1x24x24 [25x610x610]	(1)1x24x24 [25x610x610]
<b>Refrigerant Charge Oz. [g]</b>	53.6 [1520]	53.6 [1520]	69.3 [1965]	69.3 [1965]
<b>Weights</b>				
Net Weight lbs. [kg]	441 [200]	441 [200]	477 [216]	477 [216]
Ship Weight lbs. [kg]	451 [205]	451 [205]	487 [221]	487 [221]

See Page 12 for Notes.

[ ] Designates Metric Conversions

## NOMINAL SIZES 2-5 TONS [7.0-17.6 kW]

Model RACA14 Series	060ACT***AA	060AJT***AA
<b>Cooling Performance<sup>1</sup></b>		
Gross Cooling Capacity Btu [kW]	59,000 [17.29]	59,000 [17.29]
EER/SEER <sup>2</sup>	11.6/14	11.6/14
Nominal CFM/AHRI Rated CFM [L/s]	2000/1700 [944/802]	2000/1700 [944/802]
AHRI Net Cooling Capacity Btu [kW]	57,000 [16.7]	57,000 [16.7]
Net Sensible Capacity Btu [kW]	39,500 [11.57]	39,500 [11.57]
Net Latent Capacity Btu [kW]	17,500 [5.13]	17,500 [5.13]
Net System Power kW	4.94	4.94
<b>Compressor</b>		
No./Type	1/Scroll	1/Scroll
<b>Outdoor Sound Rating (dB)<sup>3</sup></b>		
	79	79
<b>Outdoor Coil—Fin Type</b>		
	Louvered	Louvered
Tube Type	MicroChannel	MicroChannel
MicroChannel Depth in. [mm]	1 [25.4]	1 [25.4]
Face Area sq. ft. [sq. m]	15.3 [1.42]	15.3 [1.42]
Rows / FPI [FPcm]	1 / 23 [9]	1 / 23 [9]
<b>Indoor Coil—Fin Type</b>		
	Louvered	Louvered
Tube Type	MicroChannel	MicroChannel
MicroChannel Depth in. [mm]	1.26 [32]	1.26 [32]
Face Area sq. ft. [sq. m]	4 [0.37]	4 [0.37]
Rows / FPI [FPcm]	1 / 20 [8]	1 / 20 [8]
Refrigerant Control	TX Valves	TX Valves
Drain Connection No./Size in. [mm]	1/0.75 [19.05]	1/0.75 [19.05]
<b>Outdoor Fan—Type</b>		
	Propeller	Propeller
No. Used/Diameter in. [mm]	1/22 [558.8]	1/22 [558.8]
Drive Type/No. Speeds	Direct/1	Direct/1
CFM [L/s]	3400 [1604]	3400 [1604]
No. Motors/HP	1 at 1/3 HP	1 at 1/3 HP
Motor RPM	1075	1075
<b>Indoor Fan—Type</b>		
	FC Centrifugal	FC Centrifugal
No. Used/Diameter in. [mm]	1/12x9 [305x229]	1/12x9 [305x229]
Drive Type	Direct	Direct
No. Speeds	Multiple	Multiple
No. Motors	1	1
Motor HP	1	1
Motor RPM	1075	1075
Motor Frame Size	48	48
<b>Filter—Type</b>		
	Field Supplied	Field Supplied
Furnished	No	No
(NO.) Size Recommended in. [mm x mm x mm]	(1)1x24x30 [25x610x762]	(1)1x24x30 [25x610x762]
<b>Refrigerant Charge Oz. [g]</b>		
	83.1 [2356]	83.1 [2356]
<b>Weights</b>		
Net Weight lbs. [kg]	512 [232]	512 [232]
Ship Weight lbs. [kg]	522 [237]	522 [237]

See Page 12 for Notes.

[ ] Designates Metric Conversions



## NOMINAL SIZES 2-5 TONS [7.0-17.6 kW]

Model RACA15 Series	024AJT***AA	030AJT***AA	036ACT***AA	036AJT***AA
<b>Cooling Performance<sup>1</sup></b>				<b>CONTINUED</b> →
Gross Cooling Capacity Btu [kW]	24,600 [7.21]	29,600 [8.67]	36,000 [10.55]	36,000 [10.55]
EER/SEER <sup>2</sup>	12/15	12/15	12/15	12/15
Nominal CFM/AHRI Rated CFM [L/s]	800/900 [378/425]	1000/975 [472/460]	1200/1200 [566/566]	1200/1200 [566/566]
AHRI Net Cooling Capacity Btu [kW]	24,000 [7.03]	29,000 [8.5]	35,000 [10.25]	35,000 [10.25]
Net Sensible Capacity Btu [kW]	18,100 [5.3]	21,500 [6.3]	25,400 [7.44]	25,400 [7.44]
Net Latent Capacity Btu [kW]	5,900 [1.73]	7,500 [2.2]	9,600 [2.81]	9,600 [2.81]
Net System Power kW	2.03	2.21	2.77	2.77
<b>Compressor</b>				
No./Type	1/Scroll	1/Scroll	1/Scroll	1/Scroll
<b>Outdoor Sound Rating (dB)<sup>3</sup></b>	76	76	76	76
<b>Outdoor Coil—Fin Type</b>	Louvered	Louvered	Louvered	Louvered
Tube Type	MicroChannel	MicroChannel	MicroChannel	MicroChannel
MicroChannel Depth in. [mm]	0.71 [18]	0.71 [18]	0.71 [18]	0.71 [18]
Face Area sq. ft. [sq. m]	7.1 [0.66]	9.9 [0.92]	9.8 [0.91]	9.8 [0.91]
Rows / FPI [FPcm]	1 / 23 [9]	1 / 23 [9]	1 / 23 [9]	1 / 23 [9]
<b>Indoor Coil—Fin Type</b>	Louvered	Louvered	Louvered	Louvered
Tube Type	MicroChannel	MicroChannel	MicroChannel	MicroChannel
MicroChannel Depth in. [mm]	1 [25.4]	1 [25.4]	1 [25.4]	1 [25.4]
Face Area sq. ft. [sq. m]	3.6 [0.33]	3.6 [0.33]	3.6 [0.33]	3.6 [0.33]
Rows / FPI [FPcm]	1 / 17 [7]	1 / 17 [7]	1 / 17 [7]	1 / 17 [7]
Refrigerant Control	TX Valves	TX Valves	TX Valves	TX Valves
Drain Connection No./Size in. [mm]	1/0.75 [19.05]	1/0.75 [19.05]	1/0.75 [19.05]	1/0.75 [19.05]
<b>Outdoor Fan—Type</b>	Propeller	Propeller	Propeller	Propeller
No. Used/Diameter in. [mm]	1/22 [558.8]	1/22 [558.8]	1/22 [558.8]	1/22 [558.8]
Drive Type/No. Speeds	Direct/1	Direct/1	Direct/1	Direct/1
CFM [L/s]	2500 [1180]	2500 [1180]	2700 [1274]	2700 [1274]
No. Motors/HP	1 at 1/3 HP	1 at 1/3 HP	1 at 1/3 HP	1 at 1/3 HP
Motor RPM	1075	1075	1075	1075
<b>Indoor Fan—Type</b>	FC Centrifugal	FC Centrifugal	FC Centrifugal	FC Centrifugal
No. Used/Diameter in. [mm]	1/10x9 [254x229]	1/10x9 [254x229]	1/12x9 [305x229]	1/12x9 [305x229]
Drive Type	Direct	Direct	Direct	Direct
No. Speeds	Multiple	Multiple	Multiple	Multiple
No. Motors	1	1	1	1
Motor HP	1/3	1/2	1/2	1/2
Motor RPM	1075	1075	1075	1075
Motor Frame Size	48	48	48	48
<b>Filter—Type</b>	Field Supplied	Field Supplied	Field Supplied	Field Supplied
Furnished	No	No	No	No
(NO.) Size Recommended in. [mm x mm x mm]	(1)1x20x20 [25x508x508]	(1)1x24x24 [25x610x610]	(1)1x24x24 [25x610x610]	(1)1x24x24 [25x610x610]
<b>Refrigerant Charge Oz. [g]</b>	42.6 [1208]	46.8 [1327]	52.7 [1494]	52.7 [1494]
<b>Weights</b>				
Net Weight lbs. [kg]	403 [183]	403 [183]	411 [186]	411 [186]
Ship Weight lbs. [kg]	413 [187]	413 [187]	421 [191]	421 [191]

See Page 12 for Notes.

[ ] Designates Metric Conversions

## NOMINAL SIZES 2-5 TONS [7.0-17.6 kW]

Model RACA15 Series	042ACT***AA	042AJT***AA	048ACT***AA	048AJT***AA
<b>Cooling Performance<sup>1</sup></b>				<b>CONTINUED</b> 
Gross Cooling Capacity Btu [kW]	41,000 [12.01]	41,000 [12.01]	47,500 [13.92]	47,500 [13.92]
EER/SEER <sup>2</sup>	12/15	12/15	12/15	12/15
Nominal CFM/AHRI Rated CFM [L/s]	1400/1300 [661/613]	1400/1300 [661/613]	1600/1550 [755/731]	1600/1550 [755/731]
AHRI Net Cooling Capacity Btu [kW]	40,000 [11.72]	40,000 [11.72]	46,000 [13.48]	46,000 [13.48]
Net Sensible Capacity Btu [kW]	28,600 [8.38]	28,600 [8.38]	33,000 [9.67]	33,000 [9.67]
Net Latent Capacity Btu [kW]	11,400 [3.34]	11,400 [3.34]	13,000 [3.81]	13,000 [3.81]
Net System Power kW	3.28	3.28	3.66	3.66
<b>Compressor</b>				
No./Type	1/Scroll	1/Scroll	1/Scroll	1/Scroll
<b>Outdoor Sound Rating (dB)<sup>3</sup></b>	76	76	78	78
<b>Outdoor Coil—Fin Type</b>	Louvered	Louvered	Louvered	Louvered
Tube Type	MicroChannel	MicroChannel	MicroChannel	MicroChannel
MicroChannel Depth in. [mm]	0.71 [18]	0.71 [18]	0.71 [18]	0.7 [17.8]
Face Area sq. ft. [sq. m]	14.1 [1.31]	14.1 [1.31]	16.3 [1.51]	16.3 [1.51]
Rows / FPI [FPcm]	1 / 23 [9]	1 / 23 [9]	1 / 23 [9]	1 / 23 [9]
<b>Indoor Coil—Fin Type</b>	Louvered	Louvered	Louvered	Louvered
Tube Type	MicroChannel	MicroChannel	MicroChannel	MicroChannel
MicroChannel Depth in. [mm]	1 [25.4]	1 [25.4]	1.26 [32]	1.26 [32]
Face Area sq. ft. [sq. m]	3.6 [0.33]	3.6 [0.33]	4.1 [0.38]	4.1 [0.38]
Rows / FPI [FPcm]	1 / 17 [7]	1 / 17 [7]	1 / 20 [8]	1 / 20 [8]
Refrigerant Control	TX Valves	TX Valves	TX Valves	TX Valves
Drain Connection No./Size in. [mm]	1/0.75 [19.05]	1/0.75 [19.05]	1/0.75 [19.05]	1/0.75 [19.05]
<b>Outdoor Fan—Type</b>	Propeller	Propeller	Propeller	Propeller
No. Used/Diameter in. [mm]	1/22 [558.8]	1/22 [558.8]	1/22 [558.8]	1/22 [558.8]
Drive Type/No. Speeds	Direct/1	Direct/1	Direct/1	Direct/1
CFM [L/s]	3500 [1652]	3500 [1652]	3300 [1557]	3300 [1557]
No. Motors/HP	1 at 1/3 HP	1 at 1/3 HP	1 at 1/3 HP	1 at 1/3 HP
Motor RPM	1075	1075	1075	1075
<b>Indoor Fan—Type</b>	FC Centrifugal	FC Centrifugal	FC Centrifugal	FC Centrifugal
No. Used/Diameter in. [mm]	1/12x9 [305x229]	1/12x9 [305x229]	1/12x9 [305x229]	1/12x9 [305x229]
Drive Type	Direct	Direct	Direct	Direct
No. Speeds	Multiple	Multiple	Multiple	Multiple
No. Motors	1	1	1	1
Motor HP	3/4	3/4	3/4	3/4
Motor RPM	1075	1075	1075	1075
Motor Frame Size	48	48	48	48
<b>Filter—Type</b>	Field Supplied	Field Supplied	Field Supplied	Field Supplied
Furnished	No	No	No	No
(NO.) Size Recommended in. [mm x mm x mm]	(1)1x24x24 [25x610x610]	(1)1x24x24 [25x610x610]	(1)1x24x24 [25x610x610]	(1)1x24x24 [25x610x610]
<b>Refrigerant Charge Oz. [g]</b>	61.3 [1738]	61.3 [1738]	85.3 [2418]	85.3 [2418]
<b>Weights</b>				
Net Weight lbs. [kg]	445 [202]	445 [202]	492 [223]	492 [223]
Ship Weight lbs. [kg]	455 [206]	455 [206]	502 [228]	502 [228]

See Page 12 for Notes.

[ ] Designates Metric Conversions

## NOMINAL SIZES 2-5 TONS [7.0-17.6 kW]

Model RACA15 Series	060ACT***AA	060AJT***AA
<b>Cooling Performance<sup>1</sup></b>		
Gross Cooling Capacity (2nd Stage) Btu [kW]	59,500 [17.43]	59,500 [17.43]
SEER <sup>2</sup>	15	15
EER (1st stage / 2nd stage)	20.9/11.4	20.9/11.4
AHRI Rated CFM (1st / 2nd stage) [L/s]	1250/1850 [590/873]	1250/1850 [590/873]
AHRI Net Cooling Capacity (1st / 2nd stage) Btu [kW]	49,500/57,000 [14.5/16.7]	49,500/57,000 [14.5/16.7]
Net Sensible Capacity (1st / 2nd stage) Btu [kW]	33,800/40,700 [9.9/11.92]	33,800/40,700 [9.9/11.92]
Net Latent Capacity (1st / 2nd stage) Btu [kW]	15,700/16,300 [4.6/4.78]	15,700/16,300 [4.6/4.78]
Net System Power (1st / 2nd stage) [kW]	2.14/5.02	2.14/5.02
<b>Compressor</b>		
No./Type	1/Scroll	1/Scroll
<b>Outdoor Sound Rating (dB)<sup>3</sup></b>		
	78	78
<b>Outdoor Coil—Fin Type</b>		
	Louvered	Louvered
Tube Type	MicroChannel	MicroChannel
MicroChannel Depth in. [mm]	1 [25.4]	1 [25.4]
Face Area sq. ft. [sq. m]	15.3 [1.42]	15.3 [1.42]
Rows / FPI [FPcm]	1 / 23 [9]	1 / 23 [9]
<b>Indoor Coil—Fin Type</b>		
	Louvered	Louvered
Tube Type	MicroChannel	MicroChannel
MicroChannel Depth in. [mm]	1.26 [32]	1.26 [32]
Face Area sq. ft. [sq. m]	4 [0.37]	4 [0.37]
Rows / FPI [FPcm]	1 / 20 [8]	1 / 20 [8]
Refrigerant Control	TX Valves	TX Valves
Drain Connection No./Size in. [mm]	1/0.75 [19.05]	1/0.75 [19.05]
<b>Outdoor Fan—Type</b>		
	Propeller	Propeller
No. Used/Diameter in. [mm]	1/22 [558.8]	1/22 [558.8]
Drive Type/No. Speeds	Direct/1	Direct/1
CFM [L/s]	3300 [1557]	3300 [1557]
No. Motors/HP	1 at 1/3 HP	1 at 1/3 HP
Motor RPM	1075	1075
<b>Indoor Fan—Type</b>		
	FC Centrifugal	FC Centrifugal
No. Used/Diameter in. [mm]	1/12x9 [305x229]	1/12x9 [305x229]
Drive Type	Direct	Direct
No. Speeds	Multiple	Multiple
No. Motors	1	1
Motor HP	1	1
Motor RPM	1075	1075
Motor Frame Size	48	48
<b>Filter—Type</b>		
	Field Supplied	Field Supplied
Furnished	No	No
(NO.) Size Recommended in. [mm x mm x mm]	(1)1x24x30 [25x610x762]	(1)1x24x30 [25x610x762]
<b>Refrigerant Charge Oz. [g]</b>		
	89.6 [2540]	89.6 [2540]
<b>Weights</b>		
Net Weight lbs. [kg]	515 [234]	515 [234]
Ship Weight lbs. [kg]	525 [238]	525 [238]

See Page 12 for Notes.

[ ] Designates Metric Conversions

## NOTES:

1. Cooling Performance is rated at 95° F ambient, 80° F entering dry bulb, 67° F entering wet bulb. Gross capacity does not include the effect of fan motor heat. AHRI capacity is net and includes the effect of fan motor heat. Units are suitable for operation in CFM range shown in airflow tables. Units are certified in accordance with the Unitary Air Conditioner Equipment certification program, which is based on AHRI Standard 210/240 or 360.
2. EER and/or SEER are rated at AHRI conditions and in accordance with DOE test procedures.
3. Outdoor Sound Rating shown is tested in accordance with AHRI Standard 270.



## GROSS SYSTEMS PERFORMANCE DATA—RACA14024A

		ENTERING INDOOR AIR @ 80°F [26.7°C] dbE ①									
wbE		71°F [21.7°C]			67°F [19.4°C]			63°F [17.2°C]			
CFM [L/s]		990 [467]	900 [425]	760 [359]	990 [467]	900 [425]	760 [359]	990 [467]	900 [425]	760 [359]	
DR ①		0.18	0.15	0.12	0.18	0.15	0.12	0.18	0.15	0.12	
OUTDOOR DRY BULB TEMPERATURE °F [°C]	75 [23.9]	Total BTUH [kW] Sens BTUH [kW] Power	31.2 [9.1] 19.3 [5.7] 1.4	30.6 [9.0] 18.5 [5.4] 1.4	29.7 [8.7] 17.1 [5.0] 1.4	29.3 [8.6] 22.6 [6.6] 1.4	28.8 [8.4] 21.6 [6.3] 1.4	28.0 [8.2] 20.0 [5.9] 1.4	27.8 [8.2] 25.3 [7.4] 1.4	27.3 [8.0] 24.2 [7.1] 1.4	26.6 [7.8] 22.5 [6.6] 1.4
	80 [26.7]	Total BTUH [kW] Sens BTUH [kW] Power	30.1 [8.8] 18.7 [5.5] 1.5	29.6 [8.7] 17.9 [5.2] 1.5	28.8 [8.4] 16.6 [4.9] 1.5	28.3 [8.3] 22.0 [6.4] 1.5	27.8 [8.2] 21.0 [6.2] 1.5	27.0 [7.9] 19.5 [5.7] 1.5	26.8 [7.9] 24.7 [7.2] 1.5	26.3 [7.7] 23.6 [6.9] 1.5	25.6 [7.5] 21.9 [6.4] 1.5
	85 [29.4]	Total BTUH [kW] Sens BTUH [kW] Power	29.1 [8.5] 18.1 [5.3] 1.6	28.6 [8.4] 17.3 [5.1] 1.6	27.8 [8.1] 16.0 [4.7] 1.6	27.3 [8.0] 21.4 [6.3] 1.6	26.8 [7.9] 20.4 [6.0] 1.6	26.1 [7.6] 18.9 [5.5] 1.6	25.8 [7.6] 24.1 [7.1] 1.6	25.4 [7.4] 23.0 [6.8] 1.6	24.6 [7.2] 21.4 [6.3] 1.6
	90 [32.2]	Total BTUH [kW] Sens BTUH [kW] Power	28.1 [8.2] 17.5 [5.1] 1.7	27.6 [8.1] 16.7 [4.9] 1.7	26.8 [7.9] 15.5 [4.5] 1.7	26.3 [7.7] 20.8 [6.1] 1.7	25.8 [7.6] 19.8 [5.8] 1.7	25.1 [7.4] 18.4 [5.4] 1.7	24.8 [7.3] 23.5 [6.9] 1.7	24.4 [7.1] 22.5 [6.6] 1.7	23.7 [6.9] 20.8 [6.1] 1.7
	95 [35]	Total BTUH [kW] Sens BTUH [kW] Power	27.1 [7.9] 16.9 [5.0] 1.8	26.6 [7.8] 16.1 [4.7] 1.8	25.9 [7.6] 15.0 [4.4] 1.8	25.3 [7.4] 20.2 [5.9] 1.8	24.9 [7.3] 19.3 [5.6] 1.8	24.2 [7.1] 17.9 [5.2] 1.8	23.8 [7.0] 22.9 [6.7] 1.8	23.4 [6.8] 21.9 [6.4] 1.8	22.7 [6.7] 20.3 [5.9] 1.8
	100 [37.8]	Total BTUH [kW] Sens BTUH [kW] Power	26.1 [7.6] 16.3 [4.8] 2.0	25.6 [7.5] 15.6 [4.6] 1.9	24.9 [7.3] 14.4 [4.2] 1.9	24.3 [7.1] 19.6 [5.7] 2.0	23.9 [7.0] 18.7 [5.5] 1.9	23.2 [6.8] 17.3 [5.1] 1.9	22.8 [6.7] 22.3 [6.5] 2.0	22.4 [6.6] 21.3 [6.2] 1.9	21.7 [6.4] 19.8 [5.8] 1.9
	105 [40.6]	Total BTUH [kW] Sens BTUH [kW] Power	25.1 [7.4] 15.7 [4.6] 2.1	24.6 [7.2] 15.0 [4.4] 2.1	23.9 [7.0] 13.9 [4.1] 2.1	23.3 [6.8] 19.0 [5.6] 2.1	22.9 [6.7] 18.1 [5.3] 2.1	22.2 [6.5] 16.8 [4.9] 2.0	21.8 [6.4] 21.7 [6.4] 2.1	21.4 [6.3] 20.7 [6.1] 2.1	20.8 [6.1] 19.2 [5.6] 2.0
	110 [43.3]	Total BTUH [kW] Sens BTUH [kW] Power	24.1 [7.1] 15.1 [4.4] 2.2	23.6 [6.9] 14.4 [4.2] 2.2	23.0 [6.7] 13.4 [3.9] 2.2	22.3 [6.5] 18.4 [5.4] 2.2	21.9 [6.4] 17.5 [5.1] 2.2	21.2 [6.2] 16.3 [4.8] 2.2	20.7 [6.1] 20.7 [6.1] 2.2	20.4 [6.0] 20.2 [5.9] 2.2	19.8 [5.8] 18.7 [5.5] 2.2
	115 [46.1]	Total BTUH [kW] Sens BTUH [kW] Power	23.1 [6.8] 14.5 [4.3] 2.4	22.6 [6.6] 13.9 [4.1] 2.4	22.0 [6.4] 12.9 [3.8] 2.3	21.2 [6.2] 17.8 [5.2] 2.4	20.9 [6.1] 17.0 [5.0] 2.4	20.3 [5.9] 15.7 [4.6] 2.3	19.7 [5.8] 19.7 [5.8] 2.4	19.4 [5.7] 19.4 [5.7] 2.4	18.8 [5.5] 18.2 [5.3] 2.3
	120 [48.9]	Total BTUH [kW] Sens BTUH [kW] Power	22.0 [6.5] 13.9 [4.1] 2.6	21.6 [6.3] 13.3 [3.9] 2.5	21.0 [6.2] 12.3 [3.6] 2.5	20.2 [5.9] 17.2 [5.0] 2.6	19.9 [5.8] 16.4 [4.8] 2.5	19.3 [5.7] 15.2 [4.5] 2.5	18.7 [5.5] 18.7 [5.5] 2.6	18.4 [5.4] 18.4 [5.4] 2.5	17.9 [5.2] 17.7 [5.2] 2.5
	125 [51.7]	Total BTUH [kW] Sens BTUH [kW] Power	21.0 [6.2] 13.3 [3.9] 2.7	20.6 [6.0] 12.7 [3.7] 2.7	20.1 [5.9] 11.8 [3.5] 2.7	19.2 [5.6] 16.6 [4.9] 2.7	18.9 [5.5] 15.8 [4.6] 2.7	18.3 [5.4] 14.7 [4.3] 2.7	17.7 [5.2] 17.7 [5.2] 2.7	17.4 [5.1] 17.4 [5.1] 2.7	16.9 [4.9] 16.9 [4.9] 2.7

DR —Depression ratio  
dbE —Entering air dry bulb  
wbE—Entering air wet bulb

Total —Total capacity x 1000 BTUH  
Sens —Sensible capacity x 1000 BTUH  
Power —KW input

NOTES: ① When the entering air dry bulb is other than 80°F [27°C], adjust the sensible capacity from the table by adding [1.10 x CFM x (1 – DR) x (dbE – 80)].

[ ] Designates Metric Conversions





## GROSS SYSTEMS PERFORMANCE DATA—RACA14030A

		ENTERING INDOOR AIR @ 80°F [26.7°C] dbE ①									
wbE		71°F [21.7°C]			67°F [19.4°C]			63°F [17.2°C]			
CFM [L/s]		1100 [519]	1000 [472]	850 [401]	1100 [519]	1000 [472]	850 [401]	1100 [519]	1000 [472]	850 [401]	
DR ②		0.16	0.15	0.11	0.16	0.15	0.11	0.16	0.15	0.11	
OUTDOOR DRY BULB TEMPERATURE °F [°C]	75 [23.9]	Total BTUH [kW] Sens BTUH [kW] Power	37.0 [10.9] 21.6 [6.3] 1.7	36.4 [10.7] 20.6 [6.0] 1.6	35.4 [10.4] 19.2 [5.6] 1.6	35.0 [10.3] 25.6 [7.5] 1.7	34.4 [10.1] 24.4 [7.2] 1.6	33.4 [9.8] 22.7 [6.7] 1.6	33.2 [9.7] 28.8 [8.4] 1.6	32.6 [9.6] 27.5 [8.1] 1.6	31.7 [9.3] 25.6 [7.5] 1.6
	80 [26.7]	Total BTUH [kW] Sens BTUH [kW] Power	36.0 [10.5] 21.1 [6.2] 1.7	35.4 [10.4] 20.1 [5.9] 1.7	34.4 [10.1] 18.7 [5.5] 1.7	33.9 [9.9] 25.1 [7.4] 1.7	33.3 [9.8] 24.0 [7.0] 1.7	32.4 [9.5] 22.3 [6.5] 1.7	32.2 [9.4] 28.3 [8.3] 1.7	31.6 [9.3] 27.0 [7.9] 1.7	30.7 [9.0] 25.1 [7.4] 1.7
	85 [29.4]	Total BTUH [kW] Sens BTUH [kW] Power	34.9 [10.2] 20.6 [6.0] 1.8	34.3 [10.1] 19.7 [5.8] 1.8	33.4 [9.8] 18.3 [5.4] 1.8	32.9 [9.6] 24.6 [7.2] 1.8	32.3 [9.5] 23.5 [6.9] 1.8	31.4 [9.2] 21.8 [6.4] 1.8	31.1 [9.1] 27.8 [8.1] 1.8	30.6 [9.0] 26.5 [7.8] 1.8	29.7 [8.7] 24.7 [7.2] 1.8
	90 [32.2]	Total BTUH [kW] Sens BTUH [kW] Power	33.9 [9.9] 20.1 [5.9] 1.9	33.3 [9.7] 19.2 [5.6] 1.9	32.3 [9.5] 17.8 [5.2] 1.9	31.8 [9.3] 24.1 [7.1] 1.9	31.2 [9.2] 23.0 [6.7] 1.9	30.4 [8.9] 21.4 [6.3] 1.9	30.0 [8.8] 27.3 [8.0] 1.9	29.5 [8.6] 26.0 [7.6] 1.9	28.7 [8.4] 24.2 [7.1] 1.9
	95 [35]	Total BTUH [kW] Sens BTUH [kW] Power	32.8 [9.6] 19.5 [5.7] 2.1	32.2 [9.4] 18.6 [5.5] 2.0	31.3 [9.2] 17.3 [5.1] 2.0	30.7 [9.0] 23.5 [6.9] 2.0	30.2 [8.8] 22.5 [6.6] 2.0	29.3 [8.6] 20.9 [6.1] 2.0	28.9 [8.5] 26.7 [7.8] 2.0	28.4 [8.3] 25.5 [7.5] 2.0	27.6 [8.1] 23.7 [7.0] 2.0
	100 [37.8]	Total BTUH [kW] Sens BTUH [kW] Power	31.6 [9.3] 18.9 [5.5] 2.2	31.1 [9.1] 18.1 [5.3] 2.2	30.2 [8.9] 16.8 [4.9] 2.1	29.6 [8.7] 22.9 [6.7] 2.2	29.1 [8.5] 21.9 [6.4] 2.1	28.3 [8.3] 20.4 [6.0] 2.1	27.8 [8.2] 26.1 [7.7] 2.2	27.3 [8.0] 25.0 [7.3] 2.1	26.6 [7.8] 23.2 [6.8] 2.1
	105 [40.6]	Total BTUH [kW] Sens BTUH [kW] Power	30.5 [8.9] 18.3 [5.4] 2.3	30.0 [8.8] 17.5 [5.1] 2.3	29.2 [8.5] 16.3 [4.8] 2.3	28.5 [8.3] 22.3 [6.5] 2.3	28.0 [8.2] 21.3 [6.2] 2.3	27.2 [8.0] 19.8 [5.8] 2.2	26.7 [7.8] 25.5 [7.5] 2.3	26.2 [7.7] 24.4 [7.1] 2.3	25.5 [7.5] 22.7 [6.6] 2.2
	110 [43.3]	Total BTUH [kW] Sens BTUH [kW] Power	29.4 [8.6] 17.7 [5.2] 2.4	28.8 [8.5] 16.9 [5.0] 2.4	28.1 [8.2] 15.7 [4.6] 2.4	27.3 [8.0] 21.7 [6.4] 2.4	26.8 [7.9] 20.7 [6.1] 2.4	26.1 [7.6] 19.3 [5.6] 2.4	25.5 [7.5] 24.9 [7.3] 2.4	25.1 [7.4] 23.8 [7.0] 2.4	24.4 [7.2] 22.1 [6.5] 2.4
	115 [46.1]	Total BTUH [kW] Sens BTUH [kW] Power	28.2 [8.3] 17.0 [5.0] 2.6	27.7 [8.1] 16.3 [4.8] 2.6	26.9 [7.9] 15.1 [4.4] 2.5	26.1 [7.7] 21.0 [6.2] 2.6	25.7 [7.5] 20.1 [5.9] 2.6	25.0 [7.3] 18.7 [5.5] 2.5	24.4 [7.1] 24.2 [7.1] 2.6	23.9 [7.0] 23.1 [6.8] 2.5	23.3 [6.8] 21.5 [6.3] 2.5
	120 [48.9]	Total BTUH [kW] Sens BTUH [kW] Power	27.0 [7.9] 16.3 [4.8] 2.7	26.5 [7.8] 15.6 [4.6] 2.7	25.8 [7.6] 14.5 [4.3] 2.7	25.0 [7.3] 20.3 [6.0] 2.7	24.5 [7.2] 19.4 [5.7] 2.7	23.9 [7.0] 18.1 [5.3] 2.7	23.2 [6.8] 23.2 [6.8] 2.7	22.8 [6.7] 22.5 [6.6] 2.7	22.2 [6.5] 20.9 [6.1] 2.7
	125 [51.7]	Total BTUH [kW] Sens BTUH [kW] Power	25.8 [7.6] 15.6 [4.6] 2.9	25.4 [7.4] 14.9 [4.4] 2.9	24.7 [7.2] 13.9 [4.1] 2.8	23.8 [7.0] 19.6 [5.8] 2.9	23.3 [6.8] 18.8 [5.5] 2.9	22.7 [6.7] 17.4 [5.1] 2.8	22.0 [6.4] 22.0 [6.4] 2.9	21.6 [6.3] 21.6 [6.3] 2.9	21.0 [6.2] 20.3 [5.9] 2.8

DR —Depression ratio  
dbE —Entering air dry bulb  
wbE —Entering air wet bulb

Total —Total capacity x 1000 BTUH  
Sens —Sensible capacity x 1000 BTUH  
Power —KW input

NOTES: ① When the entering air dry bulb is other than 80°F [27°C], adjust the sensible capacity from the table by adding [1.10 x CFM x (1 - DR) x (dbE - 80)].

[ ] Designates Metric Conversions





# GROSS SYSTEMS PERFORMANCE DATA – RACA14036A

		ENTERING INDOOR AIR @ 80°F [26.7°C] dbE ①									
wbE		71°F [21.7°C]			67°F [19.4°C]			63°F [17.2°C]			
CFM [L/s]		1320 [623]	1200 [566]	1020 [481]	1320 [623]	1200 [566]	1020 [481]	1320 [623]	1200 [566]	1020 [481]	
DR ①		0.23	0.21	0.18	0.23	0.21	0.18	0.23	0.21	0.18	
OUTDOOR DRY BULB TEMPERATURE	75 [23.9]	Total BTUH [kW] Sens BTUH [kW] Power	44.3 [13.0] 25.4 [7.4] 2.0	43.5 [12.8] 24.2 [7.1] 2.0	42.3 [12.4] 22.5 [6.6] 2.0	41.4 [12.1] 29.6 [8.7] 2.0	40.6 [11.9] 28.3 [8.3] 2.0	39.5 [11.6] 26.3 [7.7] 2.0	38.3 [11.2] 32.8 [9.6] 2.0	37.6 [11.0] 31.3 [9.2] 2.0	36.6 [10.7] 29.1 [8.5] 2.0
	80 [26.7]	Total BTUH [kW] Sens BTUH [kW] Power	43.0 [12.6] 24.7 [7.2] 2.1	42.2 [12.4] 23.6 [6.9] 2.1	41.1 [12.0] 21.9 [6.4] 2.1	40.0 [11.7] 28.9 [8.5] 2.1	39.3 [11.5] 27.6 [8.1] 2.1	38.2 [11.2] 25.7 [7.5] 2.1	37.0 [10.8] 32.1 [9.4] 2.1	36.3 [10.6] 30.7 [9.0] 2.1	35.3 [10.3] 28.5 [8.4] 2.1
	85 [29.4]	Total BTUH [kW] Sens BTUH [kW] Power	41.7 [12.2] 24.0 [7.0] 2.3	40.9 [12.0] 22.9 [6.7] 2.2	39.8 [11.7] 21.3 [6.2] 2.2	38.7 [11.3] 28.2 [8.3] 2.2	38.0 [11.1] 27.0 [7.9] 2.2	37.0 [10.8] 25.1 [7.3] 2.2	35.6 [10.4] 31.4 [9.2] 2.2	35.0 [10.3] 30.0 [8.8] 2.2	34.0 [10.0] 27.9 [8.2] 2.2
	90 [32.2]	Total BTUH [kW] Sens BTUH [kW] Power	40.3 [11.8] 23.2 [6.8] 2.4	39.6 [11.6] 22.2 [6.5] 2.4	38.5 [11.3] 20.7 [6.1] 2.3	37.3 [10.9] 27.5 [8.1] 2.4	36.7 [10.7] 26.3 [7.7] 2.4	35.7 [10.5] 24.4 [7.2] 2.3	34.3 [10.0] 30.7 [9.0] 2.4	33.7 [9.9] 29.3 [8.6] 2.4	32.7 [9.6] 27.3 [8.0] 2.3
	95 [35]	Total BTUH [kW] Sens BTUH [kW] Power	38.9 [11.4] 22.5 [6.6] 2.5	38.3 [11.2] 21.5 [6.3] 2.5	37.2 [10.9] 20.0 [5.9] 2.5	36.0 [10.5] 26.7 [7.8] 2.5	35.3 [10.4] 25.5 [7.5] 2.5	34.4 [10.1] 23.7 [7.0] 2.5	32.9 [9.6] 29.9 [8.8] 2.5	32.3 [9.5] 28.6 [8.4] 2.5	31.4 [9.2] 26.6 [7.8] 2.5
	100 [37.8]	Total BTUH [kW] Sens BTUH [kW] Power	37.6 [11.0] 21.7 [6.4] 2.7	36.9 [10.8] 20.7 [6.1] 2.7	35.9 [10.5] 19.3 [5.7] 2.6	34.6 [10.1] 25.9 [7.6] 2.7	34.0 [10.0] 24.8 [7.3] 2.7	33.0 [9.7] 23.0 [6.8] 2.6	31.5 [9.2] 29.1 [8.5] 2.7	30.9 [9.1] 27.8 [8.2] 2.6	30.1 [8.8] 25.9 [7.6] 2.6
	105 [40.6]	Total BTUH [kW] Sens BTUH [kW] Power	36.1 [10.6] 20.9 [6.1] 2.9	35.5 [10.4] 20.0 [5.8] 2.8	34.5 [10.1] 18.6 [5.4] 2.8	33.2 [9.7] 25.1 [7.4] 2.8	32.6 [9.5] 24.0 [7.0] 2.8	31.7 [9.3] 22.3 [6.5] 2.8	30.1 [8.8] 28.3 [8.3] 2.8	29.6 [8.7] 27.1 [7.9] 2.8	28.7 [8.4] 25.2 [7.4] 2.8
	110 [43.3]	Total BTUH [kW] Sens BTUH [kW] Power	34.7 [10.2] 20.1 [5.9] 3.0	34.1 [10.0] 19.2 [5.6] 3.0	33.2 [9.7] 17.8 [5.2] 3.0	31.7 [9.3] 24.3 [7.1] 3.0	31.2 [9.1] 23.2 [6.8] 3.0	30.3 [8.9] 21.6 [6.3] 3.0	28.7 [8.4] 27.5 [8.1] 3.0	28.2 [8.3] 26.3 [7.7] 3.0	27.4 [8.0] 24.4 [7.2] 3.0
	115 [46.1]	Total BTUH [kW] Sens BTUH [kW] Power	33.3 [9.8] 19.2 [5.6] 3.2	32.7 [9.6] 18.3 [5.4] 3.2	31.8 [9.3] 17.0 [5.0] 3.2	30.3 [8.9] 23.4 [6.9] 3.2	29.8 [8.7] 22.4 [6.6] 3.2	28.9 [8.5] 20.8 [6.1] 3.2	27.2 [8.0] 26.6 [7.8] 3.2	26.7 [7.8] 25.4 [7.5] 3.2	26.0 [7.6] 23.7 [6.9] 3.1
	120 [48.9]	Total BTUH [kW] Sens BTUH [kW] Power	31.8 [9.3] 18.3 [5.4] 3.4	31.2 [9.2] 17.5 [5.1] 3.4	30.4 [8.9] 16.3 [4.8] 3.4	28.8 [8.5] 22.5 [6.6] 3.4	28.3 [8.3] 21.5 [6.3] 3.4	27.5 [8.1] 20.0 [5.9] 3.4	25.8 [7.5] 25.7 [7.5] 3.4	25.3 [7.4] 24.6 [7.2] 3.4	24.6 [7.2] 22.9 [6.7] 3.3
125 [51.7]	Total BTUH [kW] Sens BTUH [kW] Power	30.3 [8.9] 17.4 [5.1] 3.6	29.8 [8.7] 16.6 [4.9] 3.6	29.0 [8.5] 15.4 [4.5] 3.6	27.4 [8.0] 21.6 [6.3] 3.6	26.9 [7.9] 20.7 [6.1] 3.6	26.1 [7.7] 19.2 [5.6] 3.6	24.3 [7.1] 24.3 [7.1] 3.6	23.8 [7.0] 23.7 [6.9] 3.6	23.2 [6.8] 22.0 [6.5] 3.6	

DR —Depression ratio  
dbE —Entering air dry bulb  
wbE—Entering air wet bulb

Total —Total capacity x 1000 BTUH  
Sens —Sensible capacity x 1000 BTUH  
Power—KW input

NOTES: ① When the entering air dry bulb is other than 80°F [27°C], adjust the sensible capacity from the table by adding [1.10 x CFM x (1 – DR) x (dbE – 80)].

[ ] Designates Metric Conversions





## GROSS SYSTEMS PERFORMANCE DATA—RACA14042A

		ENTERING INDOOR AIR @ 80°F [26.7°C] dbE ①									
wbE		71°F [21.7°C]			67°F [19.4°C]			63°F [17.2°C]			
CFM [L/s]		1430 [675]	1300 [614]	1100 [519]	1430 [675]	1300 [614]	1100 [519]	1430 [675]	1300 [614]	1100 [519]	
DR ①		0.15	0.14	0.1	0.15	0.14	0.1	0.15	0.14	0.1	
OUTDOOR DRY BULB TEMPERATURE °F [°C]	75 [23.9]	Total BTUH [kW] Sens BTUH [kW] Power	50.0 [14.7] 29.2 [8.5] 2.4	49.1 [14.4] 27.9 [8.2] 2.4	47.7 [14.0] 25.9 [7.6] 2.3	47.3 [13.9] 34.3 [10.0] 2.4	46.4 [13.6] 32.7 [9.6] 2.3	45.1 [13.2] 30.4 [8.9] 2.3	44.3 [13.0] 38.5 [11.3] 2.3	43.5 [12.8] 36.8 [10.8] 2.3	42.3 [12.4] 34.2 [10.0] 2.3
	80 [26.7]	Total BTUH [kW] Sens BTUH [kW] Power	48.7 [14.3] 28.5 [8.4] 2.5	47.9 [14.0] 27.3 [8.0] 2.5	46.5 [13.6] 25.3 [7.4] 2.5	46.0 [13.5] 33.7 [9.9] 2.5	45.2 [13.2] 32.2 [9.4] 2.5	43.9 [12.9] 29.8 [8.7] 2.4	43.0 [12.6] 37.9 [11.1] 2.5	42.3 [12.4] 36.2 [10.6] 2.5	41.1 [12.0] 33.6 [9.9] 2.4
	85 [29.4]	Total BTUH [kW] Sens BTUH [kW] Power	47.4 [13.9] 27.9 [8.2] 2.7	46.6 [13.6] 26.6 [7.8] 2.6	45.2 [13.3] 24.7 [7.2] 2.6	44.7 [13.1] 33.0 [9.7] 2.6	43.9 [12.9] 31.5 [9.2] 2.6	42.6 [12.5] 29.3 [8.6] 2.6	41.7 [12.2] 37.2 [10.9] 2.6	41.0 [12.0] 35.6 [10.4] 2.6	39.8 [11.7] 33.0 [9.7] 2.6
	90 [32.2]	Total BTUH [kW] Sens BTUH [kW] Power	46.0 [13.5] 27.2 [8.0] 2.8	45.2 [13.2] 26.0 [7.6] 2.8	43.9 [12.9] 24.1 [7.1] 2.8	43.3 [12.7] 32.3 [9.5] 2.8	42.5 [12.5] 30.8 [9.0] 2.8	41.3 [12.1] 28.6 [8.4] 2.7	40.3 [11.8] 36.5 [10.7] 2.8	39.6 [11.6] 34.9 [10.2] 2.8	38.5 [11.3] 32.4 [9.5] 2.7
	95 [35]	Total BTUH [kW] Sens BTUH [kW] Power	44.6 [13.1] 26.4 [7.7] 3.0	43.8 [12.8] 25.2 [7.4] 3.0	42.6 [12.5] 23.4 [6.9] 2.9	41.8 [12.3] 31.5 [9.2] 3.0	41.1 [12.0] 30.1 [8.8] 3.0	39.9 [11.7] 27.9 [8.2] 2.9	38.9 [11.4] 35.8 [10.5] 3.0	38.2 [11.2] 34.2 [10.0] 2.9	37.1 [10.9] 31.7 [9.3] 2.9
	100 [37.8]	Total BTUH [kW] Sens BTUH [kW] Power	43.1 [12.6] 25.6 [7.5] 3.2	42.3 [12.4] 24.4 [7.2] 3.1	41.1 [12.1] 22.7 [6.6] 3.1	40.4 [11.8] 30.7 [9.0] 3.2	39.6 [11.6] 29.3 [8.6] 3.1	38.5 [11.3] 27.2 [8.0] 3.1	37.4 [11.0] 34.9 [10.2] 3.1	36.7 [10.8] 33.4 [9.8] 3.1	35.7 [10.5] 31.0 [9.1] 3.1
	105 [40.6]	Total BTUH [kW] Sens BTUH [kW] Power	41.6 [12.2] 24.7 [7.2] 3.4	40.8 [12.0] 23.6 [6.9] 3.3	39.7 [11.6] 21.9 [6.4] 3.3	38.8 [11.4] 29.8 [8.7] 3.3	38.1 [11.2] 28.5 [8.3] 3.3	37.1 [10.9] 26.4 [7.7] 3.3	35.9 [10.5] 34.1 [10.0] 3.3	35.2 [10.3] 32.5 [9.5] 3.3	34.3 [10.0] 30.2 [8.8] 3.3
	110 [43.3]	Total BTUH [kW] Sens BTUH [kW] Power	40.0 [11.7] 23.8 [7.0] 3.6	39.3 [11.5] 22.7 [6.7] 3.5	38.2 [11.2] 21.1 [6.2] 3.5	37.2 [10.9] 28.9 [8.5] 3.5	36.6 [10.7] 27.6 [8.1] 3.5	35.6 [10.4] 25.6 [7.5] 3.5	34.3 [10.0] 33.1 [9.7] 3.5	33.7 [9.9] 31.6 [9.3] 3.5	32.7 [9.6] 29.4 [8.6] 3.5
	115 [46.1]	Total BTUH [kW] Sens BTUH [kW] Power	38.3 [11.2] 22.8 [6.7] 3.8	37.7 [11.0] 21.8 [6.4] 3.7	36.6 [10.7] 20.2 [5.9] 3.7	35.6 [10.4] 27.9 [8.2] 3.8	35.0 [10.2] 26.6 [7.8] 3.7	34.0 [10.0] 24.7 [7.2] 3.7	32.7 [9.6] 32.1 [9.4] 3.7	32.1 [9.4] 30.7 [9.0] 3.7	31.2 [9.1] 28.5 [8.4] 3.7
	120 [48.9]	Total BTUH [kW] Sens BTUH [kW] Power	36.7 [10.7] 21.7 [6.4] 4.0	36.0 [10.6] 20.8 [6.1] 4.0	35.0 [10.3] 19.3 [5.6] 3.9	33.9 [9.9] 26.8 [7.9] 4.0	33.3 [9.8] 25.6 [7.5] 3.9	32.4 [9.5] 23.8 [7.0] 3.9	31.0 [9.1] 31.0 [9.1] 4.0	30.4 [8.9] 29.7 [8.7] 3.9	29.6 [8.7] 27.6 [8.1] 3.9
	125 [51.7]	Total BTUH [kW] Sens BTUH [kW] Power	34.9 [10.2] 20.6 [6.1] 4.2	34.3 [10.1] 19.7 [5.8] 4.2	33.3 [9.8] 18.3 [5.4] 4.1	32.2 [9.4] 25.8 [7.5] 4.2	31.6 [9.3] 24.6 [7.2] 4.2	30.7 [9.0] 22.8 [6.7] 4.1	29.2 [8.6] 29.2 [8.6] 4.2	28.7 [8.4] 28.7 [8.4] 4.1	27.9 [8.2] 26.6 [7.8] 4.1

DR —Depression ratio  
dbE —Entering air dry bulb  
wbE —Entering air wet bulb

Total —Total capacity x 1000 BTUH  
Sens —Sensible capacity x 1000 BTUH  
Power —KW input

NOTES: ① When the entering air dry bulb is other than 80°F [27°C], adjust the sensible capacity from the table by adding [1.10 x CFM x (1 - DR) x (dbE - 80)].

[ ] Designates Metric Conversions





# GROSS SYSTEMS PERFORMANCE DATA – RACA14048A

ENTERING INDOOR AIR @ 80°F [26.7°C] dbE ①											
wbE		71°F [21.7°C]			67°F [19.4°C]			63°F [17.2°C]			
CFM [L/s]		1700 [802]	1550 [732]	1320 [623]	1700 [802]	1550 [732]	1320 [623]	1700 [802]	1550 [732]	1320 [623]	
DR ①		0.21	0.19	0.17	0.21	0.19	0.17	0.21	0.19	0.17	
OUTDOOR DRY BULB TEMPERATURE °F [°C]	75 [23.9]	Total BTUH [kW] Sens BTUH [kW] Power	58.8 [17.2] 33.0 [9.7] 2.8	57.8 [16.9] 31.6 [9.3] 2.8	56.3 [16.5] 29.4 [8.6] 2.7	55.4 [16.2] 39.1 [11.5] 2.8	54.4 [15.9] 37.4 [11.0] 2.7	53.0 [15.5] 34.8 [10.2] 2.7	52.6 [15.4] 45.0 [13.2] 2.7	51.7 [15.1] 43.0 [12.6] 2.7	50.3 [14.7] 40.1 [11.7] 2.7
	80 [26.7]	Total BTUH [kW] Sens BTUH [kW] Power	57.1 [16.7] 32.2 [9.4] 2.9	56.1 [16.4] 30.8 [9.0] 2.9	54.6 [16.0] 28.7 [8.4] 2.9	53.6 [15.7] 38.3 [11.2] 2.9	52.7 [15.4] 36.6 [10.7] 2.9	51.3 [15.0] 34.1 [10.0] 2.9	50.8 [14.9] 44.2 [12.9] 2.9	49.9 [14.6] 42.3 [12.4] 2.9	48.6 [14.2] 39.3 [11.5] 2.8
	85 [29.4]	Total BTUH [kW] Sens BTUH [kW] Power	55.3 [16.2] 31.4 [9.2] 3.1	54.4 [15.9] 30.0 [8.8] 3.1	52.9 [15.5] 27.9 [8.2] 3.0	51.9 [15.2] 37.4 [11.0] 3.1	51.0 [14.9] 35.8 [10.5] 3.1	49.6 [14.5] 33.3 [9.8] 3.0	49.1 [14.4] 43.3 [12.7] 3.1	48.2 [14.1] 41.4 [12.1] 3.0	46.9 [13.7] 38.6 [11.3] 3.0
	90 [32.2]	Total BTUH [kW] Sens BTUH [kW] Power	53.6 [15.7] 30.4 [8.9] 3.3	52.6 [15.4] 29.1 [8.5] 3.3	51.2 [15.0] 27.1 [7.9] 3.2	50.1 [14.7] 36.5 [10.7] 3.3	49.2 [14.4] 34.9 [10.2] 3.2	47.9 [14.0] 32.5 [9.5] 3.2	47.3 [13.9] 42.4 [12.4] 3.2	46.5 [13.6] 40.6 [11.9] 3.2	45.2 [13.3] 37.8 [11.1] 3.2
	95 [35]	Total BTUH [kW] Sens BTUH [kW] Power	51.8 [15.2] 29.5 [8.6] 3.5	50.9 [14.9] 28.2 [8.3] 3.5	49.5 [14.5] 26.3 [7.7] 3.4	48.4 [14.2] 35.6 [10.4] 3.5	47.5 [13.9] 34.0 [10.0] 3.4	46.3 [13.6] 31.7 [9.3] 3.4	45.6 [13.4] 41.5 [12.1] 3.4	44.8 [13.1] 39.7 [11.6] 3.4	43.6 [12.8] 36.9 [10.8] 3.4
	100 [37.8]	Total BTUH [kW] Sens BTUH [kW] Power	50.1 [14.7] 28.5 [8.4] 3.7	49.2 [14.4] 27.3 [8.0] 3.7	47.9 [14.0] 25.4 [7.4] 3.6	46.6 [13.7] 34.6 [10.1] 3.7	45.8 [13.4] 33.1 [9.7] 3.7	44.6 [13.1] 30.8 [9.0] 3.6	43.8 [12.8] 40.5 [11.9] 3.7	43.1 [12.6] 38.7 [11.3] 3.6	41.9 [12.3] 36.0 [10.6] 3.6
	105 [40.6]	Total BTUH [kW] Sens BTUH [kW] Power	48.4 [14.2] 27.5 [8.1] 4.0	47.5 [13.9] 26.3 [7.7] 3.9	46.2 [13.5] 24.5 [7.2] 3.9	44.9 [13.2] 33.6 [9.8] 3.9	44.1 [12.9] 32.1 [9.4] 3.9	42.9 [12.6] 29.9 [8.8] 3.8	42.1 [12.3] 39.4 [11.6] 3.9	41.4 [12.1] 37.7 [11.1] 3.9	40.3 [11.8] 35.1 [10.3] 3.8
	110 [43.3]	Total BTUH [kW] Sens BTUH [kW] Power	46.6 [13.7] 26.4 [7.7] 4.2	45.8 [13.4] 25.3 [7.4] 4.2	44.6 [13.1] 23.5 [6.9] 4.1	43.2 [12.7] 32.5 [9.5] 4.2	42.4 [12.4] 31.1 [9.1] 4.2	41.3 [12.1] 28.9 [8.5] 4.1	40.4 [11.8] 38.4 [11.2] 4.2	39.7 [11.6] 36.7 [10.8] 4.1	38.6 [11.3] 34.2 [10.0] 4.1
	115 [46.1]	Total BTUH [kW] Sens BTUH [kW] Power	44.9 [13.2] 25.3 [7.4] 4.5	44.1 [12.9] 24.2 [7.1] 4.5	42.9 [12.6] 22.6 [6.6] 4.4	41.5 [12.2] 31.4 [9.2] 4.5	40.8 [11.9] 30.0 [8.8] 4.4	39.7 [11.6] 28.0 [8.2] 4.4	38.7 [11.3] 37.3 [10.9] 4.4	38.0 [11.1] 35.7 [10.5] 4.4	37.0 [10.8] 33.2 [9.7] 4.4
	120 [48.9]	Total BTUH [kW] Sens BTUH [kW] Power	43.2 [12.7] 24.2 [7.1] 4.8	42.5 [12.4] 23.1 [6.8] 4.8	41.3 [12.1] 21.5 [6.3] 4.7	39.8 [11.7] 30.3 [8.9] 4.8	39.1 [11.4] 28.9 [8.5] 4.7	38.0 [11.1] 26.9 [7.9] 4.7	37.0 [10.8] 36.1 [10.6] 4.7	36.3 [10.6] 34.6 [10.1] 4.7	35.3 [10.4] 32.2 [9.4] 4.6
	125 [51.7]	Total BTUH [kW] Sens BTUH [kW] Power	41.5 [12.2] 23.0 [6.7] 5.1	40.8 [12.0] 22.0 [6.4] 5.1	39.7 [11.6] 20.5 [6.0] 5.0	38.1 [11.2] 29.1 [8.5] 5.1	37.4 [11.0] 27.8 [8.2] 5.0	36.4 [10.7] 25.9 [7.6] 5.0	35.3 [10.3] 35.0 [10.2] 5.1	34.6 [10.2] 33.4 [9.8] 5.0	33.7 [9.9] 31.1 [9.1] 5.0

DR —Depression ratio  
 dbE —Entering air dry bulb  
 wbE—Entering air wet bulb

Total —Total capacity x 1000 BTUH  
 Sens —Sensible capacity x 1000 BTUH  
 Power—KW input

**NOTES:** ① When the entering air dry bulb is other than 80°F [27°C], adjust the sensible capacity from the table by adding [1.10 x CFM x (1 – DR) x (dbE – 80)].

[ ] Designates Metric Conversions



## GROSS SYSTEMS PERFORMANCE DATA—RACA14060A

		ENTERING INDOOR AIR @ 80°F [26.7°C] dbE ①									
wbE		71°F [21.7°C]			67°F [19.4°C]			63°F [17.2°C]			
CFM [L/s]		1870 [883]	1700 [802]	1440 [680]	1870 [883]	1700 [802]	1440 [680]	1870 [883]	1700 [802]	1440 [680]	
DR ①		0.14	0.13	0.11	0.14	0.13	0.11	0.14	0.13	0.11	
OUTDOOR DRY BULB TEMPERATURE °F [°C]	75 [23.9]	Total BTUH [kW] Sens BTUH [kW] Power	72.1 [21.1] 40.6 [11.9] 3.5	70.8 [20.7] 38.8 [11.4] 3.5	68.8 [20.2] 36.0 [10.6] 3.5	67.8 [19.9] 47.8 [14.0] 3.5	66.6 [19.5] 45.7 [13.4] 3.5	64.7 [19.0] 42.4 [12.4] 3.4	63.6 [18.6] 54.4 [16.0] 3.5	62.4 [18.3] 52.0 [15.2] 3.5	60.7 [17.8] 48.3 [14.2] 3.4
	80 [26.7]	Total BTUH [kW] Sens BTUH [kW] Power	70.3 [20.6] 39.6 [11.6] 3.7	69.0 [20.2] 37.8 [11.1] 3.7	67.1 [19.7] 35.1 [10.3] 3.7	66.0 [19.3] 46.7 [13.7] 3.7	64.8 [19.0] 44.7 [13.1] 3.7	63.0 [18.5] 41.5 [12.2] 3.6	61.8 [18.1] 53.4 [15.6] 3.7	60.7 [17.8] 51.0 [15.0] 3.6	59.0 [17.3] 47.4 [13.9] 3.6
	85 [29.4]	Total BTUH [kW] Sens BTUH [kW] Power	68.4 [20.0] 38.5 [11.3] 4.0	67.1 [19.7] 36.8 [10.8] 3.9	65.3 [19.1] 34.1 [10.0] 3.9	64.1 [18.8] 45.7 [13.4] 3.9	62.9 [18.4] 43.6 [12.8] 3.9	61.2 [17.9] 40.5 [11.9] 3.8	59.9 [17.5] 52.3 [15.3] 3.9	58.8 [17.2] 50.0 [14.6] 3.9	57.2 [16.7] 46.4 [13.6] 3.8
	90 [32.2]	Total BTUH [kW] Sens BTUH [kW] Power	66.4 [19.5] 37.3 [10.9] 4.2	65.2 [19.1] 35.7 [10.5] 4.1	63.4 [18.6] 33.1 [9.7] 4.1	62.1 [18.2] 44.5 [13.1] 4.2	61.0 [17.9] 42.6 [12.5] 4.1	59.3 [17.4] 39.5 [11.6] 4.1	57.9 [17.0] 51.2 [15.0] 4.1	56.8 [16.7] 48.9 [14.3] 4.1	55.3 [16.2] 45.4 [13.3] 4.0
	95 [35]	Total BTUH [kW] Sens BTUH [kW] Power	64.3 [18.8] 36.2 [10.6] 4.4	63.2 [18.5] 34.6 [10.1] 4.4	61.4 [18.0] 32.1 [9.4] 4.3	60.0 [17.6] 43.4 [12.7] 4.4	58.9 [17.3] 41.4 [12.1] 4.4	57.3 [16.8] 38.5 [11.3] 4.3	55.8 [16.4] 50.0 [14.7] 4.4	54.8 [16.1] 47.8 [14.0] 4.3	53.3 [15.6] 44.4 [13.0] 4.3
	100 [37.8]	Total BTUH [kW] Sens BTUH [kW] Power	62.1 [18.2] 35.0 [10.3] 4.7	61.0 [17.9] 33.4 [9.8] 4.7	59.3 [17.4] 31.0 [9.1] 4.6	57.9 [17.0] 42.2 [12.4] 4.7	56.8 [16.7] 40.3 [11.8] 4.6	55.2 [16.2] 37.4 [11.0] 4.6	53.6 [15.7] 48.8 [14.3] 4.7	52.7 [15.4] 46.7 [13.7] 4.6	51.2 [15.0] 43.3 [12.7] 4.5
	105 [40.6]	Total BTUH [kW] Sens BTUH [kW] Power	59.9 [17.5] 33.8 [9.9] 5.0	58.8 [17.2] 32.3 [9.5] 5.0	57.2 [16.8] 30.0 [8.8] 4.9	55.6 [16.3] 41.0 [12.0] 5.0	54.6 [16.0] 39.1 [11.5] 4.9	53.1 [15.6] 36.3 [10.6] 4.9	51.4 [15.1] 47.6 [14.0] 4.9	50.5 [14.8] 45.5 [13.3] 4.9	49.1 [14.4] 42.2 [12.4] 4.8
	110 [43.3]	Total BTUH [kW] Sens BTUH [kW] Power	57.6 [16.9] 32.5 [9.5] 5.3	56.5 [16.6] 31.0 [9.1] 5.3	55.0 [16.1] 28.8 [8.4] 5.2	53.3 [15.6] 39.7 [11.6] 5.3	52.3 [15.3] 37.9 [11.1] 5.2	50.9 [14.9] 35.2 [10.3] 5.2	49.0 [14.4] 46.3 [13.6] 5.2	48.2 [14.1] 44.3 [13.0] 5.2	46.8 [13.7] 41.1 [12.0] 5.1
	115 [46.1]	Total BTUH [kW] Sens BTUH [kW] Power	55.1 [16.2] 31.2 [9.1] 5.6	54.1 [15.9] 29.8 [8.7] 5.6	52.6 [15.4] 27.7 [8.1] 5.5	50.8 [14.9] 38.4 [11.2] 5.6	49.9 [14.6] 36.7 [10.7] 5.5	48.5 [14.2] 34.0 [10.0] 5.5	46.6 [13.7] 45.0 [13.2] 5.6	45.8 [13.4] 43.0 [12.6] 5.5	44.5 [13.0] 40.0 [11.7] 5.4
	120 [48.9]	Total BTUH [kW] Sens BTUH [kW] Power	52.6 [15.4] 29.8 [8.7] 6.0	51.7 [15.1] 28.5 [8.4] 5.9	50.2 [14.7] 26.5 [7.8] 5.8	48.3 [14.2] 37.0 [10.8] 5.9	47.5 [13.9] 35.4 [10.4] 5.9	46.1 [13.5] 32.8 [9.6] 5.8	44.1 [12.9] 43.7 [12.8] 5.9	43.3 [12.7] 41.7 [12.2] 5.9	42.1 [12.3] 38.8 [11.4] 5.8
	125 [51.7]	Total BTUH [kW] Sens BTUH [kW] Power	50.0 [14.7] 28.5 [8.3] 6.3	49.1 [14.4] 27.2 [8.0] 6.3	47.8 [14.0] 25.2 [7.4] 6.2	45.7 [13.4] 35.6 [10.4] 6.3	44.9 [13.2] 34.1 [10.0] 6.2	43.7 [12.8] 31.6 [9.3] 6.2	41.5 [12.2] 41.5 [12.2] 6.3	40.8 [11.9] 40.4 [11.8] 6.2	39.6 [11.6] 37.5 [11.0] 6.1

DR —Depression ratio  
dbE —Entering air dry bulb  
wbE —Entering air wet bulb

Total —Total capacity x 1000 BTUH  
Sens —Sensible capacity x 1000 BTUH  
Power —KW input

NOTES: ① When the entering air dry bulb is other than 80°F [27°C], adjust the sensible capacity from the table by adding [1.10 x CFM x (1 - DR) x (dbE - 80)].

[ ] Designates Metric Conversions





# GROSS SYSTEMS PERFORMANCE DATA—RACA15024A

ENTERING INDOOR AIR @ 80°F [26.7°C] dbE ①											
wbE		71°F [21.7°C]			67°F [19.4°C]			63°F [17.2°C]			
CFM [L/s]		990 [467]	900 [425]	760 [359]	990 [467]	900 [425]	760 [359]	990 [467]	900 [425]	760 [359]	
DR ①		0.21	0.19	0.15	0.21	0.19	0.15	0.21	0.19	0.15	
OUTDOOR DRY BULB TEMPERATURE °F [°C]	75 [23.9]	Total BTUH [kW] Sens BTUH [kW] Power	30.9 [9.1] 18.7 [5.5] 1.4	30.4 [8.9] 17.9 [5.2] 1.4	29.5 [8.7] 16.6 [4.9] 1.4	29.1 [8.5] 21.9 [6.4] 1.4	28.6 [8.4] 20.9 [6.1] 1.4	27.8 [8.1] 19.4 [5.7] 1.4	27.5 [8.1] 24.6 [7.2] 1.4	27.0 [7.9] 23.5 [6.9] 1.4	26.2 [7.7] 21.8 [6.4] 1.4
	80 [26.7]	Total BTUH [kW] Sens BTUH [kW] Power	30.0 [8.8] 18.2 [5.3] 1.5	29.4 [8.6] 17.4 [5.1] 1.5	28.6 [8.4] 16.1 [4.7] 1.5	28.1 [8.2] 21.4 [6.3] 1.5	27.6 [8.1] 20.4 [6.0] 1.5	26.8 [7.9] 18.9 [5.5] 1.5	26.5 [7.8] 24.0 [7.0] 1.5	26.0 [7.6] 23.0 [6.7] 1.5	25.3 [7.4] 21.3 [6.2] 1.5
	85 [29.4]	Total BTUH [kW] Sens BTUH [kW] Power	29.0 [8.5] 17.6 [5.2] 1.6	28.5 [8.3] 16.8 [4.9] 1.6	27.7 [8.1] 15.6 [4.6] 1.6	27.1 [8.0] 20.8 [6.1] 1.6	26.7 [7.8] 19.9 [5.8] 1.6	25.9 [7.6] 18.4 [5.4] 1.6	25.5 [7.5] 23.5 [6.9] 1.6	25.1 [7.3] 22.4 [6.6] 1.6	24.4 [7.1] 20.8 [6.1] 1.6
	90 [32.2]	Total BTUH [kW] Sens BTUH [kW] Power	28.0 [8.2] 17.0 [5.0] 1.7	27.5 [8.1] 16.3 [4.8] 1.7	26.7 [7.8] 15.1 [4.4] 1.7	26.1 [7.7] 20.2 [5.9] 1.7	25.7 [7.5] 19.3 [5.7] 1.7	25.0 [7.3] 17.9 [5.3] 1.7	24.5 [7.2] 22.9 [6.7] 1.7	24.1 [7.1] 21.9 [6.4] 1.7	23.4 [6.9] 20.3 [5.9] 1.7
	95 [35]	Total BTUH [kW] Sens BTUH [kW] Power	27.0 [7.9] 16.5 [4.8] 1.9	26.5 [7.8] 15.7 [4.6] 1.8	25.7 [7.5] 14.6 [4.3] 1.8	25.1 [7.4] 19.7 [5.8] 1.8	24.7 [7.2] 18.8 [5.5] 1.8	24.0 [7.0] 17.4 [5.1] 1.8	23.5 [6.9] 22.3 [6.5] 1.8	23.1 [6.8] 21.3 [6.2] 1.8	22.4 [6.6] 19.8 [5.8] 1.8
	100 [37.8]	Total BTUH [kW] Sens BTUH [kW] Power	25.9 [7.6] 15.9 [4.6] 2.0	25.5 [7.5] 15.2 [4.4] 2.0	24.8 [7.3] 14.1 [4.1] 1.9	24.1 [7.1] 19.1 [5.6] 2.0	23.7 [6.9] 18.2 [5.3] 2.0	23.0 [6.7] 16.9 [5.0] 1.9	22.5 [6.6] 21.7 [6.4] 2.0	22.1 [6.5] 20.8 [6.1] 1.9	21.5 [6.3] 19.2 [5.6] 1.9
	105 [40.6]	Total BTUH [kW] Sens BTUH [kW] Power	24.9 [7.3] 15.3 [4.5] 2.1	24.5 [7.2] 14.6 [4.3] 2.1	23.8 [7.0] 13.5 [4.0] 2.1	23.1 [6.8] 18.5 [5.4] 2.1	22.6 [6.6] 17.7 [5.2] 2.1	22.0 [6.4] 16.4 [4.8] 2.1	21.4 [6.3] 21.1 [6.2] 2.1	21.1 [6.2] 20.2 [5.9] 2.1	20.5 [6.0] 18.7 [5.5] 2.0
	110 [43.3]	Total BTUH [kW] Sens BTUH [kW] Power	23.8 [7.0] 14.7 [4.3] 2.3	23.4 [6.9] 14.0 [4.1] 2.2	22.7 [6.7] 13.0 [3.8] 2.2	22.0 [6.4] 17.9 [5.2] 2.2	21.6 [6.3] 17.1 [5.0] 2.2	21.0 [6.1] 15.8 [4.6] 2.2	20.4 [6.0] 20.4 [6.0] 2.2	20.0 [5.9] 19.6 [5.7] 2.2	19.4 [5.7] 18.2 [5.3] 2.2
	115 [46.1]	Total BTUH [kW] Sens BTUH [kW] Power	22.8 [6.7] 14.1 [4.1] 2.4	22.3 [6.5] 13.4 [3.9] 2.4	21.7 [6.4] 12.5 [3.6] 2.3	20.9 [6.1] 17.3 [5.1] 2.4	20.5 [6.0] 16.5 [4.8] 2.4	19.9 [5.8] 15.3 [4.5] 2.3	19.3 [5.7] 19.3 [5.7] 2.4	18.9 [5.6] 18.9 [5.6] 2.4	18.4 [5.4] 17.6 [5.2] 2.3
	120 [48.9]	Total BTUH [kW] Sens BTUH [kW] Power	21.7 [6.3] 13.4 [3.9] 2.6	21.3 [6.2] 12.8 [3.8] 2.5	20.7 [6.1] 11.9 [3.5] 2.5	19.8 [5.8] 16.6 [4.9] 2.5	19.5 [5.7] 15.9 [4.7] 2.5	18.9 [5.5] 14.7 [4.3] 2.5	18.2 [5.3] 18.2 [5.3] 2.5	17.9 [5.2] 17.9 [5.2] 2.5	17.4 [5.1] 17.1 [5.0] 2.5
	125 [51.7]	Total BTUH [kW] Sens BTUH [kW] Power	20.5 [6.0] 12.8 [3.8] 2.7	20.2 [5.9] 12.2 [3.6] 2.7	19.6 [5.7] 11.3 [3.3] 2.7	18.7 [5.5] 16.0 [4.7] 2.7	18.4 [5.4] 15.3 [4.5] 2.7	17.8 [5.2] 14.2 [4.2] 2.7	17.1 [5.0] 17.1 [5.0] 2.7	16.8 [4.9] 16.8 [4.9] 2.7	16.3 [4.8] 16.3 [4.8] 2.6

DR —Depression ratio  
dbE —Entering air dry bulb  
wbE—Entering air wet bulb

Total —Total capacity x 1000 BTUH  
Sens —Sensible capacity x 1000 BTUH  
Power —KW input

NOTES: ① When the entering air dry bulb is other than 80°F [27°C], adjust the sensible capacity from the table by adding  $[1.10 \times \text{CFM} \times (1 - \text{DR}) \times (\text{dbE} - 80)]$ .

[ ] Designates Metric Conversions





## GROSS SYSTEMS PERFORMANCE DATA—RACA15030A

		ENTERING INDOOR AIR @ 80°F [26.7°C] dbE ①									
wbE		71°F [21.7°C]			67°F [19.4°C]			63°F [17.2°C]			
CFM [L/s]		1070 [505]	975 [460]	830 [392]	1070 [505]	975 [460]	830 [392]	1070 [505]	975 [460]	830 [392]	
DR ①		0.16	0.14	0.1	0.16	0.14	0.1	0.16	0.14	0.1	
OUTDOOR DRY BULB TEMPERATURE °F [°C]	75 [23.9]	Total BTUH [kW] Sens BTUH [kW] Power	36.8 [10.8] 21.5 [6.3] 1.7	36.1 [10.6] 20.5 [6.0] 1.7	35.2 [10.3] 19.1 [5.6] 1.6	34.3 [10.1] 25.1 [7.4] 1.7	33.7 [9.9] 24.0 [7.0] 1.6	32.8 [9.6] 22.4 [6.6] 1.6	32.4 [9.5] 28.3 [8.3] 1.6	31.8 [9.3] 27.1 [7.9] 1.6	31.0 [9.1] 25.2 [7.4] 1.6
	80 [26.7]	Total BTUH [kW] Sens BTUH [kW] Power	35.7 [10.5] 21.0 [6.1] 1.8	35.1 [10.3] 20.1 [5.9] 1.7	34.2 [10.0] 18.7 [5.5] 1.7	33.3 [9.7] 24.7 [7.2] 1.7	32.7 [9.6] 23.6 [6.9] 1.7	31.8 [9.3] 21.9 [6.4] 1.7	31.3 [9.2] 27.8 [8.2] 1.7	30.8 [9.0] 26.6 [7.8] 1.7	30.0 [8.8] 24.8 [7.3] 1.7
	85 [29.4]	Total BTUH [kW] Sens BTUH [kW] Power	34.7 [10.2] 20.5 [6.0] 1.9	34.1 [10.0] 19.6 [5.7] 1.8	33.2 [9.7] 18.2 [5.3] 1.8	32.2 [9.4] 24.2 [7.1] 1.8	31.7 [9.3] 23.1 [6.8] 1.8	30.8 [9.0] 21.5 [6.3] 1.8	30.3 [8.9] 27.4 [8.0] 1.8	29.8 [8.7] 26.2 [7.7] 1.8	29.0 [8.5] 24.3 [7.1] 1.8
	90 [32.2]	Total BTUH [kW] Sens BTUH [kW] Power	33.7 [9.9] 20.0 [5.9] 2.0	33.1 [9.7] 19.1 [5.6] 1.9	32.2 [9.4] 17.8 [5.2] 1.9	31.2 [9.1] 23.6 [6.9] 1.9	30.6 [9.0] 22.6 [6.6] 1.9	29.8 [8.7] 21.0 [6.2] 1.9	29.2 [8.6] 26.8 [7.9] 1.9	28.7 [8.4] 25.7 [7.5] 1.9	28.0 [8.2] 23.9 [7.0] 1.9
	95 [35]	Total BTUH [kW] Sens BTUH [kW] Power	32.6 [9.5] 19.4 [5.7] 2.1	32.0 [9.4] 18.6 [5.4] 2.1	31.2 [9.1] 17.3 [5.1] 2.0	30.1 [8.8] 23.1 [6.8] 2.1	29.6 [8.7] 22.1 [6.5] 2.0	28.8 [8.4] 20.5 [6.0] 2.0	28.2 [8.3] 26.3 [7.7] 2.0	27.7 [8.1] 25.1 [7.4] 2.0	26.9 [7.9] 23.4 [6.9] 2.0
	100 [37.8]	Total BTUH [kW] Sens BTUH [kW] Power	31.5 [9.2] 18.8 [5.5] 2.2	31.0 [9.1] 18.0 [5.3] 2.2	30.1 [8.8] 16.8 [4.9] 2.1	29.0 [8.5] 22.5 [6.6] 2.2	28.5 [8.4] 21.5 [6.3] 2.2	27.7 [8.1] 20.0 [5.9] 2.1	27.1 [7.9] 25.7 [7.5] 2.2	26.6 [7.8] 24.6 [7.2] 2.1	25.9 [7.6] 22.9 [6.7] 2.1
	105 [40.6]	Total BTUH [kW] Sens BTUH [kW] Power	30.4 [8.9] 18.2 [5.3] 2.3	29.9 [8.8] 17.4 [5.1] 2.3	29.1 [8.5] 16.2 [4.8] 2.3	27.9 [8.2] 21.9 [6.4] 2.3	27.4 [8.0] 20.9 [6.1] 2.3	26.7 [7.8] 19.5 [5.7] 2.3	26.0 [7.6] 25.1 [7.4] 2.3	25.6 [7.5] 24.0 [7.0] 2.3	24.9 [7.3] 22.3 [6.5] 2.2
	110 [43.3]	Total BTUH [kW] Sens BTUH [kW] Power	29.3 [8.6] 17.6 [5.2] 2.5	28.8 [8.4] 16.8 [4.9] 2.4	28.0 [8.2] 15.7 [4.6] 2.4	26.8 [7.9] 21.3 [6.2] 2.4	26.4 [7.7] 20.3 [6.0] 2.4	25.6 [7.5] 18.9 [5.5] 2.4	24.9 [7.3] 24.4 [7.2] 2.4	24.5 [7.2] 23.4 [6.9] 2.4	23.8 [7.0] 21.8 [6.4] 2.4
	115 [46.1]	Total BTUH [kW] Sens BTUH [kW] Power	28.2 [8.3] 16.9 [5.0] 2.6	27.7 [8.1] 16.2 [4.7] 2.6	27.0 [7.9] 15.1 [4.4] 2.5	25.7 [7.5] 20.6 [6.0] 2.6	25.3 [7.4] 19.7 [5.8] 2.6	24.6 [7.2] 18.3 [5.4] 2.5	23.8 [7.0] 23.8 [7.0] 2.6	23.4 [6.8] 22.7 [6.7] 2.6	22.7 [6.7] 21.2 [6.2] 2.5
	120 [48.9]	Total BTUH [kW] Sens BTUH [kW] Power	27.1 [7.9] 16.2 [4.8] 2.8	26.6 [7.8] 15.5 [4.5] 2.7	25.9 [7.6] 14.4 [4.2] 2.7	24.6 [7.2] 19.9 [5.8] 2.7	24.2 [7.1] 19.0 [5.6] 2.7	23.5 [6.9] 17.7 [5.2] 2.7	22.7 [6.6] 22.7 [6.6] 2.7	22.3 [6.5] 22.1 [6.5] 2.7	21.7 [6.3] 20.5 [6.0] 2.7
	125 [51.7]	Total BTUH [kW] Sens BTUH [kW] Power	25.9 [7.6] 15.5 [4.5] 2.9	25.5 [7.5] 14.8 [4.3] 2.9	24.8 [7.3] 13.8 [4.0] 2.8	23.4 [6.9] 19.2 [5.6] 2.9	23.0 [6.7] 18.3 [5.4] 2.9	22.4 [6.6] 17.1 [5.0] 2.8	21.5 [6.3] 21.5 [6.3] 2.9	21.1 [6.2] 21.1 [6.2] 2.9	20.6 [6.0] 19.9 [5.8] 2.8

DR —Depression ratio  
dbE —Entering air dry bulb  
wbE —Entering air wet bulb

Total —Total capacity x 1000 BTUH  
Sens —Sensible capacity x 1000 BTUH  
Power —KW input

NOTES: ① When the entering air dry bulb is other than 80°F [27°C], adjust the sensible capacity from the table by adding [1.10 x CFM x (1 - DR) x (dbE - 80)].

[ ] Designates Metric Conversions





## GROSS SYSTEMS PERFORMANCE DATA—RACA15036A

		ENTERING INDOOR AIR @ 80°F [26.7°C] dbE ①									
		71°F [21.7°C]			67°F [19.4°C]			63°F [17.2°C]			
wbE		1320 [623]	1200 [566]	1020 [481]	1320 [623]	1200 [566]	1020 [481]	1320 [623]	1200 [566]	1020 [481]	
CFM [L/s]		1320 [623]	1200 [566]	1020 [481]	1320 [623]	1200 [566]	1020 [481]	1320 [623]	1200 [566]	1020 [481]	
DR ①		0.19	0.18	0.15	0.19	0.18	0.15	0.19	0.18	0.15	
OUTDOOR DRY BULB TEMPERATURE °F [°C]	75 [23.9]	Total BTUH [kW] Sens BTUH [kW] Power	44.8 [13.1] 26.2 [7.7] 2.0	44.0 [12.9] 25.0 [7.3] 2.0	42.8 [12.5] 23.3 [6.8] 2.0	41.9 [12.3] 30.6 [9.0] 2.0	41.1 [12.1] 29.2 [8.6] 2.0	40.0 [11.7] 27.2 [8.0] 2.0	38.9 [11.4] 33.9 [9.9] 2.0	38.2 [11.2] 32.4 [9.5] 2.0	37.2 [10.9] 30.1 [8.8] 2.0
	80 [26.7]	Total BTUH [kW] Sens BTUH [kW] Power	43.5 [12.8] 25.4 [7.5] 2.1	42.7 [12.5] 24.3 [7.1] 2.1	41.6 [12.2] 22.6 [6.6] 2.1	40.6 [11.9] 29.9 [8.7] 2.1	39.9 [11.7] 28.5 [8.4] 2.1	38.8 [11.4] 26.5 [7.8] 2.1	37.6 [11.0] 33.2 [9.7] 2.1	36.9 [10.8] 31.7 [9.3] 2.1	35.9 [10.5] 29.5 [8.6] 2.1
	85 [29.4]	Total BTUH [kW] Sens BTUH [kW] Power	42.2 [12.4] 24.7 [7.2] 2.3	41.4 [12.1] 23.6 [6.9] 2.2	40.3 [11.8] 21.9 [6.4] 2.2	39.3 [11.5] 29.1 [8.5] 2.2	38.6 [11.3] 27.8 [8.1] 2.2	37.5 [11.0] 25.9 [7.6] 2.2	36.3 [10.6] 32.4 [9.5] 2.2	35.6 [10.4] 31.0 [9.1] 2.2	34.6 [10.2] 28.8 [8.4] 2.2
	90 [32.2]	Total BTUH [kW] Sens BTUH [kW] Power	40.9 [12.0] 23.9 [7.0] 2.4	40.1 [11.8] 22.9 [6.7] 2.4	39.0 [11.4] 21.3 [6.2] 2.3	37.9 [11.1] 28.3 [8.3] 2.4	37.2 [10.9] 27.1 [7.9] 2.4	36.2 [10.6] 25.2 [7.4] 2.3	34.9 [10.2] 31.6 [9.3] 2.4	34.3 [10.1] 30.2 [8.9] 2.3	33.4 [9.8] 28.1 [8.2] 2.3
	95 [35]	Total BTUH [kW] Sens BTUH [kW] Power	39.5 [11.6] 23.1 [6.8] 2.5	38.8 [11.4] 22.1 [6.5] 2.5	37.7 [11.1] 20.6 [6.0] 2.5	36.6 [10.7] 27.5 [8.1] 2.5	35.9 [10.5] 26.3 [7.7] 2.5	34.9 [10.2] 24.5 [7.2] 2.5	33.6 [9.8] 30.9 [9.0] 2.5	33.0 [9.7] 29.5 [8.6] 2.5	32.1 [9.4] 27.4 [8.0] 2.5
	100 [37.8]	Total BTUH [kW] Sens BTUH [kW] Power	38.1 [11.2] 22.3 [6.5] 2.7	37.5 [11.0] 21.3 [6.3] 2.7	36.4 [10.7] 19.9 [5.8] 2.6	35.2 [10.3] 26.7 [7.8] 2.7	34.6 [10.1] 25.6 [7.5] 2.7	33.6 [9.9] 23.8 [7.0] 2.6	32.2 [9.4] 30.1 [8.8] 2.7	31.6 [9.3] 28.7 [8.4] 2.6	30.8 [9.0] 26.7 [7.8] 2.6
	105 [40.6]	Total BTUH [kW] Sens BTUH [kW] Power	36.8 [10.8] 21.5 [6.3] 2.9	36.1 [10.6] 20.6 [6.0] 2.8	35.1 [10.3] 19.1 [5.6] 2.8	33.8 [9.9] 25.9 [7.6] 2.8	33.2 [9.7] 24.8 [7.3] 2.8	32.3 [9.5] 23.0 [6.7] 2.8	30.8 [9.0] 29.2 [8.6] 2.8	30.3 [8.9] 27.9 [8.2] 2.8	29.5 [8.6] 26.0 [7.6] 2.8
	110 [43.3]	Total BTUH [kW] Sens BTUH [kW] Power	35.4 [10.4] 20.7 [6.1] 3.0	34.7 [10.2] 19.8 [5.8] 3.0	33.8 [9.9] 18.4 [5.4] 3.0	32.4 [9.5] 25.1 [7.4] 3.0	31.9 [9.3] 24.0 [7.0] 3.0	31.0 [9.1] 22.3 [6.5] 3.0	29.4 [8.6] 28.4 [8.3] 3.0	28.9 [8.5] 27.1 [8.0] 3.0	28.1 [8.2] 25.2 [7.4] 2.9
	115 [46.1]	Total BTUH [kW] Sens BTUH [kW] Power	34.0 [10.0] 19.8 [5.8] 3.2	33.4 [9.8] 18.9 [5.5] 3.2	32.4 [9.5] 17.6 [5.2] 3.2	31.0 [9.1] 24.2 [7.1] 3.2	30.5 [8.9] 23.1 [6.8] 3.2	29.6 [8.7] 21.5 [6.3] 3.1	28.0 [8.2] 27.5 [8.1] 3.2	27.5 [8.1] 26.3 [7.7] 3.2	26.8 [7.8] 24.5 [7.2] 3.1
	120 [48.9]	Total BTUH [kW] Sens BTUH [kW] Power	32.5 [9.5] 18.9 [5.6] 3.4	32.0 [9.4] 18.1 [5.3] 3.4	31.1 [9.1] 16.8 [4.9] 3.4	29.6 [8.7] 23.3 [6.8] 3.4	29.1 [8.5] 22.3 [6.5] 3.4	28.3 [8.3] 20.7 [6.1] 3.3	26.6 [7.8] 26.6 [7.8] 3.4	26.1 [7.7] 25.5 [7.5] 3.4	25.4 [7.4] 23.7 [6.9] 3.3
	125 [51.7]	Total BTUH [kW] Sens BTUH [kW] Power	31.1 [9.1] 18.0 [5.3] 3.6	30.5 [9.0] 17.2 [5.1] 3.6	29.7 [8.7] 16.0 [4.7] 3.6	28.2 [8.3] 22.4 [6.6] 3.6	27.7 [8.1] 21.4 [6.3] 3.6	26.9 [7.9] 19.9 [5.8] 3.6	25.2 [7.4] 25.2 [7.4] 3.6	24.7 [7.2] 24.6 [7.2] 3.6	24.1 [7.0] 22.9 [6.7] 3.5

DR —Depression ratio  
dbE —Entering air dry bulb  
wbE—Entering air wet bulb

Total —Total capacity x 1000 BTUH  
Sens —Sensible capacity x 1000 BTUH  
Power —KW input

NOTES: ① When the entering air dry bulb is other than 80°F [27°C], adjust the sensible capacity from the table by adding  $[1.10 \times \text{CFM} \times (1 - \text{DR}) \times (\text{dbE} - 80)]$ .

[ ] Designates Metric Conversions



## GROSS SYSTEMS PERFORMANCE DATA—RACA15042A

		ENTERING INDOOR AIR @ 80°F [26.7°C] dbE ①									
wbE		71°F [21.7°C]			67°F [19.4°C]			63°F [17.2°C]			
CFM [L/s]		1430 [675]	1300 [614]	1100 [519]	1430 [675]	1300 [614]	1100 [519]	1430 [675]	1300 [614]	1100 [519]	
DR ①		0.17	0.16	0.13	0.17	0.16	0.13	0.17	0.16	0.13	
OUTDOOR DRY BULB TEMPERATURE °F [°C]	75 [23.9]	Total BTUH [kW] Sens BTUH [kW] Power	50.1 [14.7] 28.6 [8.4] 2.4	49.2 [14.4] 27.3 [8.0] 2.3	47.8 [14.0] 25.3 [7.4] 2.3	47.2 [13.8] 33.9 [9.9] 2.4	46.4 [13.6] 32.4 [9.5] 2.3	45.1 [13.2] 30.0 [8.8] 2.3	44.7 [13.1] 38.8 [11.4] 2.3	43.9 [12.9] 37.1 [10.9] 2.3	42.7 [12.5] 34.4 [10.1] 2.3
	80 [26.7]	Total BTUH [kW] Sens BTUH [kW] Power	48.8 [14.3] 27.9 [8.2] 2.5	47.9 [14.0] 26.7 [7.8] 2.5	46.6 [13.6] 24.8 [7.3] 2.5	45.9 [13.5] 33.2 [9.7] 2.5	45.1 [13.2] 31.8 [9.3] 2.5	43.8 [12.8] 29.5 [8.6] 2.4	43.4 [12.7] 38.1 [11.2] 2.5	42.6 [12.5] 36.4 [10.7] 2.5	41.5 [12.1] 33.8 [9.9] 2.4
	85 [29.4]	Total BTUH [kW] Sens BTUH [kW] Power	47.4 [13.9] 27.2 [8.0] 2.7	46.6 [13.7] 26.0 [7.6] 2.6	45.3 [13.3] 24.2 [7.1] 2.6	44.6 [13.1] 32.6 [9.5] 2.6	43.8 [12.8] 31.1 [9.1] 2.6	42.6 [12.5] 28.9 [8.5] 2.6	42.1 [12.3] 37.5 [11.0] 2.6	41.3 [12.1] 35.8 [10.5] 2.6	40.2 [11.8] 33.2 [9.7] 2.6
	90 [32.2]	Total BTUH [kW] Sens BTUH [kW] Power	46.1 [13.5] 26.5 [7.8] 2.8	45.3 [13.3] 25.3 [7.4] 2.8	44.0 [12.9] 23.5 [6.9] 2.8	43.2 [12.7] 31.8 [9.3] 2.8	42.5 [12.4] 30.4 [8.9] 2.8	41.3 [12.1] 28.2 [8.3] 2.7	40.7 [11.9] 36.8 [10.8] 2.8	40.0 [11.7] 35.1 [10.3] 2.8	38.9 [11.4] 32.6 [9.6] 2.7
	95 [35]	Total BTUH [kW] Sens BTUH [kW] Power	44.7 [13.1] 25.8 [7.6] 3.0	43.9 [12.9] 24.6 [7.2] 3.0	42.7 [12.5] 22.9 [6.7] 2.9	41.8 [12.3] 31.1 [9.1] 3.0	41.1 [12.0] 29.7 [8.7] 3.0	39.9 [11.7] 27.6 [8.1] 2.9	39.3 [11.5] 36.0 [10.5] 3.0	38.6 [11.3] 34.4 [10.1] 2.9	37.5 [11.0] 31.9 [9.4] 2.9
	100 [37.8]	Total BTUH [kW] Sens BTUH [kW] Power	43.3 [12.7] 25.0 [7.3] 3.2	42.5 [12.4] 23.9 [7.0] 3.2	41.3 [12.1] 22.1 [6.5] 3.1	40.4 [11.8] 30.3 [8.9] 3.2	39.7 [11.6] 28.9 [8.5] 3.1	38.6 [11.3] 26.9 [7.9] 3.1	37.9 [11.1] 35.2 [10.3] 3.2	37.2 [10.9] 33.6 [9.9] 3.1	36.2 [10.6] 31.2 [9.1] 3.1
	105 [40.6]	Total BTUH [kW] Sens BTUH [kW] Power	41.8 [12.2] 24.1 [7.1] 3.4	41.0 [12.0] 23.1 [6.8] 3.4	39.9 [11.7] 21.4 [6.3] 3.3	38.9 [11.4] 29.4 [8.6] 3.4	38.2 [11.2] 28.1 [8.2] 3.3	37.2 [10.9] 26.1 [7.7] 3.3	36.4 [10.7] 34.4 [10.1] 3.4	35.8 [10.5] 32.8 [9.6] 3.3	34.8 [10.2] 30.5 [8.9] 3.3
	110 [43.3]	Total BTUH [kW] Sens BTUH [kW] Power	40.3 [11.8] 23.3 [6.8] 3.6	39.6 [11.6] 22.2 [6.5] 3.6	38.5 [11.3] 20.6 [6.0] 3.5	37.4 [11.0] 28.6 [8.4] 3.6	36.8 [10.8] 27.3 [8.0] 3.5	35.7 [10.5] 25.3 [7.4] 3.5	34.9 [10.2] 33.5 [9.8] 3.6	34.3 [10.1] 32.0 [9.4] 3.5	33.3 [9.8] 29.7 [8.7] 3.5
	115 [46.1]	Total BTUH [kW] Sens BTUH [kW] Power	38.7 [11.4] 22.3 [6.5] 3.8	38.0 [11.1] 21.4 [6.3] 3.8	37.0 [10.8] 19.8 [5.8] 3.7	35.9 [10.5] 27.7 [8.1] 3.8	35.3 [10.3] 26.4 [7.7] 3.8	34.3 [10.0] 24.5 [7.2] 3.7	33.4 [9.8] 32.6 [9.5] 3.8	32.8 [9.6] 31.1 [9.1] 3.7	31.9 [9.3] 28.9 [8.5] 3.7
	120 [48.9]	Total BTUH [kW] Sens BTUH [kW] Power	37.2 [10.9] 21.4 [6.3] 4.0	36.5 [10.7] 20.4 [6.0] 4.0	35.5 [10.4] 19.0 [5.6] 3.9	34.3 [10.1] 26.7 [7.8] 4.0	33.7 [9.9] 25.5 [7.5] 4.0	32.8 [9.6] 23.7 [6.9] 3.9	31.8 [9.3] 31.6 [9.3] 4.0	31.2 [9.2] 30.2 [8.9] 4.0	30.4 [8.9] 28.0 [8.2] 3.9
	125 [51.7]	Total BTUH [kW] Sens BTUH [kW] Power	35.6 [10.4] 20.4 [6.0] 4.3	34.9 [10.2] 19.5 [5.7] 4.2	33.9 [9.9] 18.1 [5.3] 4.2	32.7 [9.6] 25.7 [7.5] 4.3	32.1 [9.4] 24.6 [7.2] 4.2	31.2 [9.2] 22.8 [6.7] 4.2	30.2 [8.8] 30.2 [8.8] 4.2	29.7 [8.7] 29.3 [8.6] 4.2	28.8 [8.4] 27.2 [8.0] 4.1

DR —Depression ratio  
dbE —Entering air dry bulb  
wbE —Entering air wet bulb

Total —Total capacity x 1000 BTUH  
Sens —Sensible capacity x 1000 BTUH  
Power —KW input

NOTES: ① When the entering air dry bulb is other than 80°F [27°C], adjust the sensible capacity from the table by adding [1.10 x CFM x (1 - DR) x (dbE - 80)].

[ ] Designates Metric Conversions





## GROSS SYSTEMS PERFORMANCE DATA – RACA15048A

		ENTERING INDOOR AIR @ 80°F [26.7°C] dbE ①									
wbE		71°F [21.7°C]			67°F [19.4°C]			63°F [17.2°C]			
CFM [L/s]		1700 [802]	1550 [732]	1320 [623]	1700 [802]	1550 [732]	1320 [623]	1700 [802]	1550 [732]	1320 [623]	
DR ①		0.19	0.18	0.15	0.19	0.18	0.15	0.19	0.18	0.15	
OUTDOOR DRY BULB TEMPERATURE °F [°C]	75 [23.9]	Total BTUH [kW] Sens BTUH [kW] Power	58.3 [17.1] 33.2 [9.7] 2.7	57.3 [16.8] 31.8 [9.3] 2.6	55.8 [16.3] 29.6 [8.7] 2.6	54.6 [16.0] 39.2 [11.5] 2.7	53.7 [15.7] 37.5 [11.0] 2.6	52.2 [15.3] 34.9 [10.2] 2.6	51.6 [15.1] 44.7 [13.1] 2.6	50.7 [14.9] 42.8 [12.5] 2.6	49.3 [14.5] 39.8 [11.7] 2.6
	80 [26.7]	Total BTUH [kW] Sens BTUH [kW] Power	56.8 [16.7] 32.5 [9.5] 2.8	55.8 [16.4] 31.1 [9.1] 2.8	54.3 [15.9] 28.9 [8.5] 2.8	53.1 [15.6] 38.5 [11.3] 2.8	52.2 [15.3] 36.8 [10.8] 2.8	50.8 [14.9] 34.3 [10.0] 2.7	50.1 [14.7] 44.0 [12.9] 2.8	49.2 [14.4] 42.1 [12.3] 2.8	47.9 [14.0] 39.2 [11.5] 2.7
	85 [29.4]	Total BTUH [kW] Sens BTUH [kW] Power	55.3 [16.2] 31.7 [9.3] 3.0	54.3 [15.9] 30.3 [8.9] 2.9	52.8 [15.5] 28.2 [8.3] 2.9	51.5 [15.1] 37.7 [11.0] 2.9	50.6 [14.8] 36.0 [10.6] 2.9	49.3 [14.4] 33.6 [9.8] 2.9	48.5 [14.2] 43.2 [12.7] 2.9	47.7 [14.0] 41.3 [12.1] 2.9	46.4 [13.6] 38.4 [11.3] 2.9
	90 [32.2]	Total BTUH [kW] Sens BTUH [kW] Power	53.6 [15.7] 30.8 [9.0] 3.1	52.7 [15.4] 29.5 [8.6] 3.1	51.3 [15.0] 27.4 [8.0] 3.1	49.9 [14.6] 36.8 [10.8] 3.1	49.0 [14.4] 35.2 [10.3] 3.1	47.7 [14.0] 32.8 [9.6] 3.0	46.9 [13.7] 42.3 [12.4] 3.1	46.1 [13.5] 40.5 [11.9] 3.1	44.8 [13.1] 37.7 [11.0] 3.0
	95 [35]	Total BTUH [kW] Sens BTUH [kW] Power	51.9 [15.2] 29.9 [8.8] 3.3	51.0 [14.9] 28.6 [8.4] 3.3	49.6 [14.5] 26.6 [7.8] 3.2	48.2 [14.1] 35.9 [10.5] 3.3	47.3 [13.9] 34.3 [10.1] 3.3	46.1 [13.5] 32.0 [9.4] 3.2	45.2 [13.2] 41.4 [12.1] 3.3	44.4 [13.0] 39.6 [11.6] 3.3	43.2 [12.7] 36.8 [10.8] 3.2
	100 [37.8]	Total BTUH [kW] Sens BTUH [kW] Power	50.1 [14.7] 28.9 [8.5] 3.5	49.2 [14.4] 27.6 [8.1] 3.5	47.9 [14.0] 25.7 [7.5] 3.4	46.4 [13.6] 34.9 [10.2] 3.5	45.6 [13.4] 33.4 [9.8] 3.5	44.3 [13.0] 31.1 [9.1] 3.4	43.4 [12.7] 40.4 [11.8] 3.5	42.6 [12.5] 38.6 [11.3] 3.4	41.5 [12.2] 36.0 [10.5] 3.4
	105 [40.6]	Total BTUH [kW] Sens BTUH [kW] Power	48.2 [14.1] 27.8 [8.2] 3.7	47.4 [13.9] 26.6 [7.8] 3.7	46.1 [13.5] 24.8 [7.3] 3.6	44.5 [13.0] 33.8 [9.9] 3.7	43.7 [12.8] 32.4 [9.5] 3.7	42.6 [12.5] 30.1 [8.8] 3.6	41.5 [12.2] 39.3 [11.5] 3.7	40.8 [12.0] 37.6 [11.0] 3.7	39.7 [11.6] 35.0 [10.3] 3.6
	110 [43.3]	Total BTUH [kW] Sens BTUH [kW] Power	46.3 [13.6] 26.7 [7.8] 3.9	45.5 [13.3] 25.6 [7.5] 3.9	44.3 [13.0] 23.8 [7.0] 3.9	42.6 [12.5] 32.7 [9.6] 3.9	41.9 [12.3] 31.3 [9.2] 3.9	40.7 [11.9] 29.1 [8.5] 3.8	39.6 [11.6] 38.2 [11.2] 3.9	38.9 [11.4] 36.6 [10.7] 3.9	37.9 [11.1] 34.0 [10.0] 3.8
	115 [46.1]	Total BTUH [kW] Sens BTUH [kW] Power	44.3 [13.0] 25.5 [7.5] 4.2	43.5 [12.8] 24.4 [7.2] 4.2	42.4 [12.4] 22.7 [6.7] 4.1	40.6 [11.9] 31.6 [9.2] 4.2	39.9 [11.7] 30.2 [8.8] 4.1	38.8 [11.4] 28.1 [8.2] 4.1	37.6 [11.0] 37.1 [10.9] 4.2	36.9 [10.8] 35.5 [10.4] 4.1	35.9 [10.5] 33.0 [9.7] 4.1
	120 [48.9]	Total BTUH [kW] Sens BTUH [kW] Power	42.2 [12.4] 24.3 [7.1] 4.4	41.5 [12.2] 23.3 [6.8] 4.4	40.4 [11.8] 21.7 [6.3] 4.3	38.5 [11.3] 30.3 [8.9] 4.4	37.9 [11.1] 29.0 [8.5] 4.4	36.8 [10.8] 27.0 [7.9] 4.3	35.5 [10.4] 35.5 [10.4] 4.4	34.9 [10.2] 34.3 [10.0] 4.4	34.0 [10.0] 31.9 [9.3] 4.3
	125 [51.7]	Total BTUH [kW] Sens BTUH [kW] Power	40.1 [11.8] 23.0 [6.7] 4.7	39.4 [11.5] 22.0 [6.5] 4.7	38.3 [11.2] 20.5 [6.0] 4.6	36.4 [10.7] 29.0 [8.5] 4.7	35.7 [10.5] 27.8 [8.1] 4.6	34.8 [10.2] 25.9 [7.6] 4.6	33.4 [9.8] 33.4 [9.8] 4.7	32.8 [9.6] 32.8 [9.6] 4.6	31.9 [9.4] 30.8 [9.0] 4.6

DR —Depression ratio  
dbE —Entering air dry bulb  
wbE—Entering air wet bulb

Total —Total capacity x 1000 BTUH  
Sens —Sensible capacity x 1000 BTUH  
Power—KW input

NOTES: ① When the entering air dry bulb is other than 80°F [27°C], adjust the sensible capacity from the table by adding  $[1.10 \times \text{CFM} \times (1 - \text{DR}) \times (\text{dbE} - 80)]$ .

[ ] Designates Metric Conversions



## GROSS SYSTEMS PERFORMANCE DATA—RACA15060A

		ENTERING INDOOR AIR @ 80°F [26.7°C] dbE ①									
wbE		71°F [21.7°C]			67°F [19.4°C]			63°F [17.2°C]			
CFM [L/s]		2040 [963]	1850 [873]	1570 [741]	2040 [963]	1850 [873]	1570 [741]	2040 [963]	1850 [873]	1570 [741]	
DR ①		0.15	0.14	0.11	0.15	0.14	0.11	0.15	0.14	0.11	
OUTDOOR DRY BULB TEMPERATURE °F [°C]	75 [23.9]	Total BTUH [kW] Sens BTUH [kW] Power	73.0 [21.4] 42.4 [12.4] 3.6	71.7 [21.0] 40.5 [11.9] 3.6	69.7 [20.4] 37.6 [11.0] 3.5	69.2 [20.3] 50.0 [14.6] 3.6	67.9 [19.9] 47.7 [14.0] 3.5	66.0 [19.3] 44.3 [13.0] 3.5	65.8 [19.3] 56.9 [16.7] 3.5	64.6 [18.9] 54.3 [15.9] 3.5	62.8 [18.4] 50.5 [14.8] 3.4
	80 [26.7]	Total BTUH [kW] Sens BTUH [kW] Power	70.9 [20.8] 41.3 [12.1] 3.8	69.6 [20.4] 39.4 [11.6] 3.7	67.7 [19.8] 36.6 [10.7] 3.7	67.1 [19.6] 48.8 [14.3] 3.7	65.8 [19.3] 46.6 [13.7] 3.7	64.0 [18.8] 43.3 [12.7] 3.6	63.7 [18.7] 55.8 [16.4] 3.7	62.5 [18.3] 53.2 [15.6] 3.7	60.8 [17.8] 49.5 [14.5] 3.6
	85 [29.4]	Total BTUH [kW] Sens BTUH [kW] Power	68.8 [20.2] 40.1 [11.8] 4.0	67.6 [19.8] 38.3 [11.2] 3.9	65.7 [19.3] 35.6 [10.4] 3.9	64.9 [19.0] 47.7 [14.0] 3.9	63.7 [18.7] 45.5 [13.3] 3.9	62.0 [18.2] 42.3 [12.4] 3.8	61.5 [18.0] 54.6 [16.0] 3.9	60.4 [17.7] 52.1 [15.3] 3.8	58.8 [17.2] 48.5 [14.2] 3.8
	90 [32.2]	Total BTUH [kW] Sens BTUH [kW] Power	66.7 [19.5] 38.9 [11.4] 4.2	65.4 [19.2] 37.2 [10.9] 4.1	63.6 [18.6] 34.5 [10.1] 4.1	62.8 [18.4] 46.5 [13.6] 4.1	61.6 [18.1] 44.3 [13.0] 4.1	59.9 [17.6] 41.2 [12.1] 4.0	59.4 [17.4] 53.4 [15.7] 4.1	58.3 [17.1] 51.0 [14.9] 4.0	56.7 [16.6] 47.4 [13.9] 4.0
	95 [35]	Total BTUH [kW] Sens BTUH [kW] Power	64.5 [18.9] 37.7 [11.0] 4.4	63.3 [18.5] 36.0 [10.5] 4.3	61.5 [18.0] 33.4 [9.8] 4.3	60.6 [17.7] 45.2 [13.3] 4.3	59.5 [17.4] 43.2 [12.6] 4.3	57.8 [16.9] 40.1 [11.8] 4.2	57.2 [16.8] 52.2 [15.3] 4.3	56.1 [16.5] 49.8 [14.6] 4.3	54.6 [16.0] 46.3 [13.6] 4.2
	100 [37.8]	Total BTUH [kW] Sens BTUH [kW] Power	62.2 [18.2] 36.4 [10.7] 4.6	61.1 [17.9] 34.7 [10.2] 4.6	59.4 [17.4] 32.3 [9.5] 4.5	58.3 [17.1] 43.9 [12.9] 4.6	57.3 [16.8] 41.9 [12.3] 4.5	55.7 [16.3] 39.0 [11.4] 4.5	55.0 [16.1] 50.9 [14.9] 4.5	54.0 [15.8] 48.6 [14.2] 4.5	52.5 [15.4] 45.1 [13.2] 4.4
	105 [40.6]	Total BTUH [kW] Sens BTUH [kW] Power	60.0 [17.6] 35.1 [10.3] 4.9	58.9 [17.3] 33.5 [9.8] 4.8	57.3 [16.8] 31.1 [9.1] 4.8	56.1 [16.4] 42.6 [12.5] 4.8	55.1 [16.1] 40.7 [11.9] 4.8	53.5 [15.7] 37.8 [11.1] 4.7	52.7 [15.4] 49.6 [14.5] 4.8	51.8 [15.2] 47.3 [13.9] 4.8	50.3 [14.7] 44.0 [12.9] 4.7
	110 [43.3]	Total BTUH [kW] Sens BTUH [kW] Power	57.7 [16.9] 33.7 [9.9] 5.2	56.6 [16.6] 32.2 [9.4] 5.1	55.1 [16.1] 29.9 [8.8] 5.0	53.8 [15.8] 41.2 [12.1] 5.1	52.8 [15.5] 39.3 [11.5] 5.1	51.4 [15.1] 36.6 [10.7] 5.0	50.4 [14.8] 48.2 [14.1] 5.1	49.5 [14.5] 46.0 [13.5] 5.0	48.1 [14.1] 42.7 [12.5] 5.0
	115 [46.1]	Total BTUH [kW] Sens BTUH [kW] Power	55.4 [16.2] 32.3 [9.5] 5.4	54.4 [15.9] 30.8 [9.0] 5.4	52.9 [15.5] 28.6 [8.4] 5.3	51.5 [15.1] 39.8 [11.7] 5.4	50.5 [14.8] 38.0 [11.1] 5.4	49.2 [14.4] 35.3 [10.3] 5.3	48.1 [14.1] 46.8 [13.7] 5.4	47.2 [13.8] 44.6 [13.1] 5.3	45.9 [13.5] 41.5 [12.2] 5.2
	120 [48.9]	Total BTUH [kW] Sens BTUH [kW] Power	53.0 [15.5] 30.8 [9.0] 5.8	52.1 [15.3] 29.4 [8.6] 5.7	50.6 [14.8] 27.3 [8.0] 5.6	49.1 [14.4] 38.4 [11.2] 5.7	48.2 [14.1] 36.6 [10.7] 5.7	46.9 [13.7] 34.0 [10.0] 5.6	45.8 [13.4] 45.3 [13.3] 5.7	44.9 [13.2] 43.2 [12.7] 5.6	43.7 [12.8] 40.2 [11.8] 5.5
	125 [51.7]	Total BTUH [kW] Sens BTUH [kW] Power	50.7 [14.8] 29.3 [8.6] 6.1	49.7 [14.6] 28.0 [8.2] 6.0	48.4 [14.2] 26.0 [7.6] 6.0	46.8 [13.7] 36.9 [10.8] 6.0	45.9 [13.5] 35.2 [10.3] 6.0	44.6 [13.1] 32.7 [9.6] 5.9	43.4 [12.7] 43.4 [12.7] 6.0	42.6 [12.5] 41.8 [12.3] 6.0	41.4 [12.1] 38.9 [11.4] 5.9

DR —Depression ratio  
dbE —Entering air dry bulb  
wbE —Entering air wet bulb

Total —Total capacity x 1000 BTUH  
Sens —Sensible capacity x 1000 BTUH  
Power —KW input

NOTES: ① When the entering air dry bulb is other than 80°F [27°C], adjust the sensible capacity from the table by adding [1.10 x CFM x (1 - DR) x (dbE - 80)].

[ ] Designates Metric Conversions





# INDOOR AIRFLOW PERFORMANCE RACA14 - 230 VOLTS



Air

Indoor Airflow Performance  
RACA14 Series

Nominal Cooling Capacity Tons [kW]	Motor Speed from Factory		Manufacturer Recommended Cooling Airflow (Min/Max)	Blower Size/ Motor HP [W] & # of Speeds	Motor Speed / Tap	External Static Pressure - Inches W.C. [kPa] (Side Discharge-Dry Coil)											
	Cool	Heat				0.1 [.02]	0.2 [.05]	0.3 [.07]	0.4 [.10]	0.5 [.12]	0.6 [.15]	0.7 [.17]	0.8 [.20]	0.9 [.22]	1.0 [.25]		
2.0 [7.03]	High	High	700 CFM / 950 CFM	9x7 Blower 1/4 HP [186] 2 Speed (PSC Motor)	Low	CFM	822 [388]	789 [372]	750 [354]	696 [328]	624 [294]	496 [234]	402 [190]				
						RPM	917	954	994	1031	1051	1075	1105				
						Watts	226	216	203	188	175	150	136				
2.5 [8.79]	Low	Low	850 CFM / 1150 CFM	10x9 Blower 1/2 HP [372] 3 Speed (PSC Motor)	Med	CFM	992 [468]	928 [438]	873 [412]	810 [382]	741 [350]	659 [311]	490 [231]				
						RPM	1055	1068	1080	1096	1106	1119	1136				
						Watts	271	256	245	227	214	199	175				
3.0 [10.55]	Low	Low	1000 CFM / 1400 CFM	12x9T Blower 1/2 HP [372] 2 Speed (PSC Motor)	High	CFM	1093 [516]	1062 [501]	1001 [472]	930 [439]	815 [385]	728 [344]	663 [313]	571 [269]			
						RPM	900	935	969	999	1030	1053	1064	1082			
						Watts	375	358	335	313	283	264	249	229			
3.5 [12.31]	Tap 3	Tap 3	1200 CFM / 1600 CFM	12x9T Blower 3/4 HP [559] 3 Speed (Constant Torque)	Tap 3	CFM	1239 [585]	1184 [559]	1114 [526]	1043 [492]	959 [453]	827 [390]	744 [351]	657 [310]			
						RPM	961	983	1006	1030	1052	1074	1084	1097			
						Watts	429	409	384	360	334	303	287	266			
3.0 [10.55]	Low	Low	1000 CFM / 1400 CFM	12x9T Blower 1/2 HP [372] 2 Speed (PSC Motor)	High	CFM	1362 [643]	1292 [610]	1213 [572]	1133 [535]	1027 [485]	872 [412]	800 [378]	700 [330]			
						RPM	1049	1061	1073	1085	1097	1109	1116	1124			
						Watts	500	472	454	427	405	371	360	339			
3.5 [12.31]	Tap 3	Tap 3	1200 CFM / 1600 CFM	12x9T Blower 3/4 HP [559] 3 Speed (Constant Torque)	Tap 3	CFM	1310 [618]	1246 [588]	1186 [560]	1128 [532]	1038 [490]	955 [451]	847 [400]	738 [348]			
						RPM	834	867	895	918	949	971	989	1019			
						Watts	460	447	435	424	407	396	380	362			
3.5 [12.31]	Tap 3	Tap 3	1200 CFM / 1600 CFM	12x9T Blower 3/4 HP [559] 3 Speed (Constant Torque)	Tap 3	CFM	1644 [776]	1568 [740]	1488 [702]	1421 [671]	1330 [628]	1248 [589]	1133 [535]	1003 [473]			
						RPM	981	996	1009	1021	1030	1048	1058	1072			
						Watts	664	641	620	600	580	560	540	526			
3.5 [12.31]	Tap 3	Tap 3	1200 CFM / 1600 CFM	12x9T Blower 3/4 HP [559] 3 Speed (Constant Torque)	Tap 3	CFM	1336 [631]	1312 [619]	1295 [611]	1241 [586]	1200 [566]	1161 [548]	1119 [528]	1072 [506]	1001 [472]	939 [443]	
						RPM	827	856	874	913	949	983	1013	1048	1092	1127	
						Watts	298	308	313	325	341	352	361	374	387	402	
3.5 [12.31]	Tap 3	Tap 3	1200 CFM / 1600 CFM	12x9T Blower 3/4 HP [559] 3 Speed (Constant Torque)	Tap 3	CFM	1336 [631]	1312 [619]	1295 [611]	1241 [586]	1200 [566]	1161 [548]	1119 [528]	1072 [506]	1001 [472]	939 [443]	
						RPM	827	856	874	913	949	983	1013	1048	1092	1127	
						Watts	298	308	313	325	341	352	361	374	387	402	
3.5 [12.31]	Tap 3	Tap 3	1200 CFM / 1600 CFM	12x9T Blower 3/4 HP [559] 3 Speed (Constant Torque)	Tap 3	CFM	1591 [751]	1563 [738]	1558 [735]	1519 [717]	1490 [703]	1458 [688]	1410 [665]	1363 [643]	1277 [603]	1122 [530]	
						RPM	949	981	999	1027	1051	1086	1109	1129	1140	1158	
						Watts	476	490	501	515	527	542	546	543	522	478	

Notes: (1) Set 3-1/2 and 4 ton Cool to Tap 2 for AHRI rated performance. (2) Set 13 SEER 5 ton Cool to Tap 2 for AHRI rated performance. (3) Set 14 SEER 5 ton Cool to Tap 1 for AHRI rated performance.

[ ] Designates Metric Conversions





# INDOOR AIRFLOW PERFORMANCE RACA14 - 230 VOLTS (continued)

Nominal Cooling Capacity Tons [kW]	Motor Speed from Factory		Manufacturer Recommended Cooling Airflow (Min/Max)	Blower Size/ Motor HP [W] & # of Speeds	Motor Speed / Tap	External Static Pressure - Inches W.C. [kPa]										
	Cool	Heat				0.1 [0.02]	0.2 [0.05]	0.3 [0.07]	0.4 [0.10]	0.5 [0.12]	0.6 [0.15]	0.7 [0.17]	0.8 [0.20]	0.9 [0.22]	1.0 [0.25]	
4.0 [14.07]	Tap 3	Tap 3	1350 CFM / 1850 CFM	12x9T Blower 3/4 HP [559] 3 Speed (Constant Torque)	Tap 1 Low	CFM	1467 [692]	1448 [683]	1404 [663]	1373 [648]	1339 [632]	1306 [616]	1250 [590]	1210 [571]	1164 [549]	1087 [513]
						RPM	826	855	884	910	939	969	1003	1030	1067	1108
						Watts	328	344	348	363	379	387	398	408	418	434
	Tap 3	Tap 3			Tap 2 Medium	CFM	1634 [771]	1595 [753]	1547 [730]	1530 [722]	1487 [702]	1462 [690]	1438 [679]	1378 [650]	1352 [638]	1298 [613]
						RPM	894	923	950	981	1000	1030	1051	1079	1106	1126
						Watts	432	446	451	468	479	490	508	510	520	520
	Tap 3	Tap 3			Tap 3 High	CFM	1941 [916]	1915 [904]	1878 [886]	1814 [856]	1773 [837]	1709 [807]	1655 [781]	1570 [741]	1488 [702]	1374 [648]
						RPM	1028	1047	1068	1091	1104	1113	1124	1136	1142	1147
						Watts	708	725	729	727	717	696	673	647	618	571
5.0 [17.59]	Tap 3	Tap 3	1600 CFM / 2100 CFM	12x9R Blower 1 HP [746] 3 Speed (Constant Torque)	Tap 1 Low	CFM	1768 [834]	1730 [816]	1693 [799]	1626 [767]	1599 [755]	1558 [735]	1522 [718]	1503 [709]	1444 [681]	1399 [660]
						RPM	938	959	983	1011	1025	1052	1089	1090	1117	1134
						Watts	520	533	541	560	563	578	599	599	605	615
	Tap 3	Tap 3			Tap 2 Medium	CFM	1926 [909]	1890 [892]	1864 [880]	1822 [860]	1794 [847]	1758 [830]	1710 [807]	1670 [788]	1579 [745]	1493 [705]
						RPM	999	1014	1040	1061	1079	1096	1119	1128	1138	1144
						Watts	654	660	674	688	699	708	714	705	683	661
	Tap 3	Tap 3			Tap 3 High	CFM	2096 [989]	2057 [971]	2003 [945]	1951 [921]	1890 [892]	1819 [858]	1756 [829]	1686 [796]	1610 [760]	1498 [707]
						RPM	1069	1092	1106	1116	1121	1129	1138	1140	1148	1154
						Watts	829	846	840	822	807	782	768	730	708	679

Notes: (1) Set 3-1/2 and 4 ton Cool to Tap 2 for AHRI rated performance. (2) Set 13 SEER 5 ton Cool to Tap 2 for AHRI rated performance. (3) Set 14 SEER 5 ton Cool to Tap 1 for AHRI rated performance.

### DOWN DISCHARGE PRESSURE DROP (ADD TO EXTERNAL STATIC PRESSURE)

CFM [L/s]	800 [378]	1000 [472]	1200 [566]	1400 [661]	1600 [755]	1800 [849]	2000 [944]
Pressure Drop—Includes W.C. [kPa]	.02 [0.005]	.05 [0.012]	.07 [0.017]	.1 [0.025]	.12 [0.030]	.15 [0.037]	.17 [0.042]

[ ] Designates Metric Conversions



# INDOOR AIRFLOW PERFORMANCE RACA14 - 208 VOLTS



Air

Indoor Airflow Performance  
RACA14 Series

Nominal Cooling Capacity Tons [kW]	Motor Speed from Factory		Manufacturer Recommended Cooling Airflow (Min/Max)	Blower Size/ Motor HP [W] & # of Speeds	Motor Speed / Tap	External Static Pressure - Inches W.C. [kPa] (Side Discharge-Dry Coil)													
	Cool	Heat				0.1 [.02]	0.2 [.05]	0.3 [.07]	0.4 [.10]	0.5 [.12]	0.6 [.15]	0.7 [.17]	0.8 [.20]	0.9 [.22]	1.0 [.25]				
2.0 [7.03]	High	High	700 CFM / 950 CFM	9x7 Blower 1/4 HP [186] 2 Speed (PSC Motor)	Low	CFM	706 [333]	685 [323]	661 [312]	614 [290]	523 [247]	437 [206]	334 [158]						
						RPM	844	886	943	989	1036	1067	1095						
						Watts	202	193	182	169	151	135	120						
2.5 [8.79]	Low	Low	850 CFM / 1150 CFM	10x9 Blower 1/2 HP [372] 3 Speed (PSC Motor)	Med	CFM	925 [437]	874 [412]	813 [384]	763 [360]	681 [321]	534 [252]	441 [208]						
						RPM	1004	1027	1058	1070	1091	1116	1128						
						Watts	253	238	220	210	192	167	155						
3.0 [10.55]	Low	Low	1000 CFM / 1400 CFM	12x9T Blower 1/2 HP [372] 2 Speed (PSC Motor)	High	CFM	967 [456]	947 [447]	892 [421]	813 [384]	740 [349]	681 [321]	613 [289]	504 [238]					
						RPM	819	876	916	966	995	1018	1040	1066					
						Watts	339	322	302	279	261	246	230	205					
3.5 [12.31]	Tap 3	Tap 3	1200 CFM / 1600 CFM	12x9T Blower 3/4 HP [559] 3 Speed (Constant Torque)	Tap 1 Low	CFM	1119 [528]	1081 [510]	1029 [486]	968 [457]	851 [402]	774 [365]	699 [330]	613 [289]					
						RPM	891	930	965	995	1026	1047	1059	1078					
						Watts	391	375	354	330	297	278	263	241					
3.5 [12.31]	Tap 3	Tap 3	1200 CFM / 1600 CFM	12x9T Blower 3/4 HP [559] 3 Speed (Constant Torque)	Tap 2 Medium	CFM	1311 [619]	1249 [589]	1168 [551]	1089 [514]	985 [465]	861 [406]	779 [368]	699 [330]					
						RPM	1010	1031	1046	1066	1080	1095	1106	1113					
						Watts	458	437	409	387	360	332	314	300					
3.5 [12.31]	Tap 3	Tap 3	1200 CFM / 1600 CFM	12x9T Blower 3/4 HP [559] 3 Speed (Constant Torque)	Tap 3 High	CFM	1163 [549]	1115 [526]	1075 [507]	1012 [478]	926 [437]	841 [397]	753 [355]	647 [305]					
						RPM	771	804	844	870	910	932	968	992					
						Watts	392	387	380	367	356	345	330	316					
3.5 [12.31]	Tap 3	Tap 3	1200 CFM / 1600 CFM	12x9T Blower 3/4 HP [559] 3 Speed (Constant Torque)	Tap 1 Low	CFM	1543 [728]	1484 [700]	1422 [671]	1345 [635]	1251 [590]	1177 [555]	1071 [505]	939 [443]					
						RPM	939	957	975	1345	1251	1177	1037	1051					
						Watts	586	572	555	535	521	517	481	459					
3.5 [12.31]	Tap 3	Tap 3	1200 CFM / 1600 CFM	12x9T Blower 3/4 HP [559] 3 Speed (Constant Torque)	Tap 2 Medium	CFM	1346 [635]	1304 [615]	1264 [597]	1232 [581]	1185 [559]	1139 [538]	1092 [515]	1048 [495]	993 [469]	908 [429]			
						RPM	819	850	883	906	944	972	1014	1047	1083	1122			
						Watts	291	302	310	319	333	338	353	362	374	389			
3.5 [12.31]	Tap 3	Tap 3	1200 CFM / 1600 CFM	12x9T Blower 3/4 HP [559] 3 Speed (Constant Torque)	Tap 3 High	CFM	1346 [635]	1304 [615]	1264 [597]	1232 [581]	1185 [559]	1139 [538]	1092 [515]	1048 [495]	993 [469]	908 [429]			
						RPM	819	850	883	906	944	972	1014	1047	1083	1122			
						Watts	291	302	310	319	333	338	353	362	374	389			
3.5 [12.31]	Tap 3	Tap 3	1200 CFM / 1600 CFM	12x9T Blower 3/4 HP [559] 3 Speed (Constant Torque)	Tap 3 High	CFM	1596 [753]	1547 [730]	1520 [717]	1499 [707]	1471 [694]	1421 [671]	1383 [653]	1332 [629]	1262 [596]	1085 [512]			
						RPM	940	973	988	1020	1038	1068	1102	1122	1136	1154			
						Watts	461	475	484	497	503	516	527	531	505	458			

Notes: (1) Set 3-1/2 and 4 ton Cool to Tap 2 for AHRI rated performance. (2) Set 13 SEER 5 ton Cool to Tap 2 for AHRI rated performance. (3) Set 14 SEER 5 ton Cool to Tap 1 for AHRI rated performance.

[ I ] Designates Metric Conversions





# INDOOR AIRFLOW PERFORMANCE RACA14 - 208 VOLTS (continued)

Nominal Cooling Capacity Tons [kW]	Motor Speed from Factory		Manufacturer Recommended Cooling Airflow (Min/Max)	Blower Size/ Motor HP [W] & # of Speeds	Motor Speed / Tap	External Static Pressure - Inches W.C. [kPa]										
	Cool	Heat				0.1 [0.02]	0.2 [0.05]	0.3 [0.07]	0.4 [0.10]	0.5 [0.12]	0.6 [0.15]	0.7 [0.17]	0.8 [0.20]	0.9 [0.22]	1.0 [0.25]	
4.0 [14.07]	Tap 3	Tap 3	1350 CFM / 1850 CFM	12x9T Blower 3/4 HP [559] 3 Speed (Constant Torque)	Tap 1 Low	CFM	1474 [696]	1431 [675]	1394 [658]	1355 [639]	1327 [626]	1284 [606]	1243 [587]	1198 [565]	1134 [535]	1064 [499]
						RPM	819	852	878	907	936	961	993	1024	1064	1101
						Watts	324	334	340	355	366	374	382	396	410	422
	Tap 3	Tap 3	1350 CFM / 1850 CFM	12x9T Blower 3/4 HP [559] 3 Speed (Constant Torque)	Tap 2 Medium	CFM	1617 [763]	1585 [748]	1547 [730]	1512 [714]	1486 [701]	1449 [684]	1430 [675]	1355 [639]	1337 [631]	1280 [604]
						RPM	891	917	940	965	992	1015	1046	1080	1098	1123
						Watts	422	433	440	451	463	475	482	496	506	507
	Tap 3	Tap 3	1350 CFM / 1850 CFM	12x9T Blower 3/4 HP [559] 3 Speed (Constant Torque)	Tap 3 High	CFM	1906 [900]	1876 [885]	1839 [868]	1807 [853]	1756 [829]	1697 [801]	1642 [775]	1555 [734]	1482 [699]	1372 [648]
						RPM	1021	1043	1064	1079	1097	1110	1123	1128	1140	1145
						Watts	679	699	694	707	698	686	671	635	610	566
5.0 [17.59]	Tap 3	Tap 3	1600 CFM / 2100 CFM	12x9R Blower 1 HP [746] 3 Speed (Constant Torque)	Tap 1 Low	CFM	1738 [820]	1680 [793]	1663 [785]	1626 [767]	1603 [757]	1554 [733]	1503 [709]	1445 [682]	1432 [676]	1386 [654]
						RPM	933	969	979	1001	1021	1045	1066	1100	1104	1125
						Watts	505	526	529	541	545	562	567	585	586	593
	Tap 3	Tap 3	1600 CFM / 2100 CFM	12x9R Blower 1 HP [746] 3 Speed (Constant Torque)	Tap 2 Medium	CFM	1884 [889]	1882 [888]	1841 [869]	1801 [850]	1760 [831]	1680 [793]	1651 [779]	1584 [748]	1508 [712]	1428 [674]
						RPM	999	1014	1048	1064	1072	1105	1121	1131	1142	1147
						Watts	636	646	661	672	675	688	686	678	662	635
	Tap 3	Tap 3	1600 CFM / 2100 CFM	12x9R Blower 1 HP [746] 3 Speed (Constant Torque)	Tap 3 High	CFM	2081 [982]	1969 [929]	2001 [944]	1960 [925]	1896 [895]	1818 [858]	1764 [833]	1664 [785]	1593 [752]	1499 [707]
						RPM	1050	1102	1095	1104	1115	1126	1130	1140	1143	1147
						Watts	790	815	819	813	793	772	749	725	699	663

Notes: (1) Set 3-1/2 and 4 ton Cool to Tap 2 for AHRI rated performance. (2) Set 13 SEER 5 ton Cool to Tap 2 for AHRI rated performance. (3) Set 14 SEER 5 ton Cool to Tap 1 for AHRI rated performance.

### DOWN DISCHARGE PRESSURE DROP (ADD TO EXTERNAL STATIC PRESSURE)

CFM [L/s]	800 [378]	1000 [472]	1200 [566]	1400 [661]	1600 [755]	1800 [849]	2000 [944]
Pressure Drop—Includes W.C. [kPa]	.02 [0.005]	.05 [0.012]	.07 [0.017]	.1 [0.025]	.12 [0.030]	.15 [0.037]	.17 [0.042]

[ ] Designates Metric Conversions





Air

# INDOOR AIRFLOW PERFORMANCE RACA15 - 460 VOLTS

Nominal Cooling Capacity Tons [kW]	Motor Speed from Factory		Manufacturer Recommended Cooling Airflow (Min/Max)	Blower Size/ Motor HP [W] & # of Speeds	Motor Speed / Tap	External Static Pressure - Inches W.C. [kPa] (Side Discharge-Dry Coil)											
	Cool	Heat				0.1 [ .02]	0.2 [ .05]	0.3 [ .07]	0.4 [ .10]	0.5 [ .12]	0.6 [ .15]	0.7 [ .17]	0.8 [ .20]	0.9 [ .22]	1.0 [ .25]		
3.0 [10.55]	Tap 3	Tap 3	1000 CFM / 1400 CFM	12x9T Blower 1/2 HP [372] 3 Speed (Constant Torque)	Tap 1 Low	CFM	1108 [523]	1081 [510]	1040 [491]	951 [449]	916 [432]	857 [404]	776 [366]	722 [341]			
						RPM	713	752	796	845	873	920	966	1001			
						Watts	188	199	213	222	229	241	252	261			
3.5 [12.31]	Tap 3	Tap 3	1200 CFM / 1600 CFM	12x9T Blower 3/4 HP [559] 3 Speed (Constant Torque)	Tap 2 Medium	CFM	1163 [549]	1144 [540]	1086 [513]	1073 [506]	987 [466]	927 [437]	870 [411]	819 [387]			
						RPM	749	761	810	836	887	920	964	1005			
						Watts	202	205	217	230	248	266	271				
4.0 [14.07]	Tap 3	Tap 3	1350 CFM / 1850 CFM	12x9T Blower 3/4 HP [559] 3 Speed (Constant Torque)	Tap 3 High	CFM	1435 [677]	1405 [663]	1378 [650]	1349 [637]	1309 [618]	1266 [597]	1233 [582]	1193 [563]	1134 [535]	1066 [503]	
						RPM	844	867	892	927	961	991	1022	1052	1101	1130	
						Watts	337	340	358	368	390	389	409	411	438	446	
3.0 [10.55]	Tap 3	Tap 3	1000 CFM / 1400 CFM	12x9T Blower 1/2 HP [372] 3 Speed (Constant Torque)	Tap 1 Low	CFM	1362 [643]	1327 [626]	1294 [611]	1267 [598]	1207 [570]	1151 [543]	1131 [534]	1085 [512]	1022 [482]	956 [451]	
						RPM	794	833	872	897	948	976	1005	1038	1078	1112	
						Watts	287	295	317	317	331	351	361	365	370	399	
3.5 [12.31]	Tap 3	Tap 3	1200 CFM / 1600 CFM	12x9T Blower 3/4 HP [559] 3 Speed (Constant Torque)	Tap 2 Medium	CFM	1362 [643]	1327 [626]	1294 [611]	1267 [598]	1207 [570]	1151 [543]	1131 [534]	1085 [512]	1022 [482]	956 [451]	
						RPM	794	833	872	897	948	976	1005	1038	1078	1112	
						Watts	287	295	317	317	331	351	361	365	370	399	
4.0 [14.07]	Tap 3	Tap 3	1350 CFM / 1850 CFM	12x9T Blower 3/4 HP [559] 3 Speed (Constant Torque)	Tap 3 High	CFM	1643 [775]	1609 [759]	1580 [746]	1560 [736]	1511 [713]	1494 [705]	1443 [681]	1404 [663]	1335 [630]	1244 [587]	
						RPM	927	954	986	1001	1035	1052	1083	1111	1122	1133	
						Watts	461	475	490	506	518	528	535	548	530	502	
3.0 [10.55]	Tap 3	Tap 3	1000 CFM / 1400 CFM	12x9T Blower 1/2 HP [372] 3 Speed (Constant Torque)	Tap 1 Low	CFM	1467 [692]	1448 [683]	1404 [663]	1373 [648]	1339 [632]	1306 [616]	1250 [590]	1210 [571]	1164 [549]	1087 [513]	
						RPM	826	855	884	910	939	969	1003	1030	1067	1108	
						Watts	328	344	348	363	379	387	398	408	418	434	
4.0 [14.07]	Tap 3	Tap 3	1350 CFM / 1850 CFM	12x9T Blower 3/4 HP [559] 3 Speed (Constant Torque)	Tap 2 Medium	CFM	1634 [771]	1595 [753]	1547 [730]	1530 [722]	1487 [702]	1462 [690]	1438 [679]	1378 [650]	1352 [638]	1298 [613]	
						RPM	894	923	950	981	1000	1030	1051	1079	1106	1126	
						Watts	432	446	451	468	479	490	508	510	520	520	
3.0 [10.55]	Tap 3	Tap 3	1000 CFM / 1400 CFM	12x9T Blower 1/2 HP [372] 3 Speed (Constant Torque)	Tap 3 High	CFM	1941 [916]	1915 [904]	1878 [886]	1814 [856]	1773 [837]	1709 [807]	1655 [781]	1570 [741]	1488 [702]	1374 [648]	
						RPM	1028	1047	1068	1091	1104	1113	1124	1136	1142	1147	
						Watts	708	725	729	727	717	696	673	647	618	571	

Notes: (1) Set 2 through 4 ton Cool to Tap 2 for AHRI rated performance. (2) Set 5 ton 1st Stage Cool to Tap 1 for AHRI rated performance.

[ ] Designates Metric Conversions





# INDOOR AIRFLOW PERFORMANCE RACA15 - 460 VOLTS (continued)

Nominal Cooling Capacity Tons [kW]	Motor Speed from Factory		Manufacturer Recommended Cooling Airflow (Min/Max)	Blower Size/ Motor HP [W] & # of Speeds	Motor Speed / Tap	External Static Pressure - Inches W.C. [kPa] (Side Discharge-Dry Coil)										
	Cool	Heat				0.1 [.02]	0.2 [.05]	0.3 [.07]	0.4 [.10]	0.5 [.12]	0.6 [.15]	0.7 [.17]	0.8 [.20]	0.9 [.22]	1.0 [.25]	
5.0 [17.59]	1st Stage Tap 2	Cool	1600 CFM / 2100 CFM	12x9R Blower 1 HP [746] 5 Speed (Constant Torque)	Tap 1	CFM	1289 [608]	1239 [585]	1189 [561]	1140 [538]	1101 [520]	1052 [496]	969 [457]	918 [433]	860 [406]	812 [383]
						RPM	726	755	786	815	846	876	912	935	964	986
						Watts	233	248	249	259	275	292	309	308	321	330
						CFM	1484 [700]	1440 [680]	1405 [663]	1360 [642]	1319 [622]	1280 [604]	1238 [584]	1186 [560]	1128 [532]	1047 [494]
						RPM	812	841	863	889	918	938	965	994	1026	1066
						Watts	330	338	355	354	379	381	395	408	423	419
	2nd Stage Tap 4	Cool	1600 CFM / 2100 CFM	12x9R Blower 1 HP [746] 5 Speed (Constant Torque)	Tap 3 Unused	CFM	1787 [843]	1746 [824]	1705 [805]	1680 [793]	1621 [765]	1607 [758]	1564 [738]	1530 [722]	1505 [710]	1424 [672]
						RPM	950	970	1000	1012	1042	1055	1079	1108	1113	1130
						Watts	525	538	545	579	571	596	615	610	631	626
						CFM	1954 [922]	1927 [909]	1889 [892]	1843 [870]	1808 [853]	1738 [820]	1671 [789]	1620 [765]	1543 [728]	1433 [676]
						RPM	1030	1042	1061	1082	1100	1121	1130	1133	1138	1146
						Watts	664	673	683	696	704	700	697	684	667	635
2nd Stage Tap 4	Cool	1600 CFM / 2100 CFM	12x9R Blower 1 HP [746] 5 Speed (Constant Torque)	Tap 5 2nd Stage High Static Cool	CFM	2095 [989]	2045 [965]	1983 [936]	1905 [899]	1840 [868]	1792 [846]	1712 [808]	1641 [774]	1558 [735]	1397 [659]	
					RPM	1103	1114	1114	1123	1125	1130	1139	1140	1144	1148	
					Watts	829	841	832	803	785	770	749	710	685	633	

Notes: (1) Set 2 through 4 ton Cool to Tap 2 for AHRI rated performance. (2) Set 5 ton 1st Stage Cool to Tap 1 for AHRI rated performance.

DOWN DISCHARGE PRESSURE DROP (ADD TO EXTERNAL STATIC PRESSURE)			
CFM [L/s]	800 [378]	1000 [472]	1200 [566]
Pressure Drop—Includes W.C. [kPa]	.02 [.005]	.05 [.012]	.07 [.017]
	1600 [755]	1800 [849]	2000 [944]
	.12 [.030]	.15 [.037]	.17 [.042]

[ J ] Designates Metric Conversions





Air

Indoor Airflow Performance  
RACA14 Series

# INDOOR AIRFLOW PERFORMANCE RACA14 - 460 VOLTS

Nominal Cooling Capacity Tons [kW]	Motor Speed from Factory		Manufacturer Recommended Cooling Airflow (Min/Max)	Blower Size/ Motor HP [W] & # of Speeds	Motor Speed / Tap	External Static Pressure - Inches W.C. [kPa] (Side Discharge-Dry Coil)										
	Cool	Heat				0.1 [ .02]	0.2 [ .05]	0.3 [ .07]	0.4 [ .10]	0.5 [ .12]	0.6 [ .15]	0.7 [ .17]	0.8 [ .20]	0.9 [ .22]	1.0 [ .25]	
3.0 [10.55]	Low	Low	1000 CFM / 1400 CFM	12x9T Blower 1/2 HP [372] 2 Speed (PSC Motor)	Low	CFM	1358 [641]	1322 [624]	1266 [597]	1209 [571]	1120 [529]	1063 [502]	970 [458]	861 [406]	828 [391]	757 [357]
						RPM	823	849	877	901	932	953	979	999	1029	1055
						Watts	505	491	481	464	447	439	422	404	393	378
3.5 [12.31]	Tap 3	Tap 3	1200 CFM / 1600 CFM	12x9T Blower 3/4 HP [559] 3 Speed (Constant Torque)	Tap 1 Low	CFM	1362 [643]	1327 [626]	1294 [611]	1267 [598]	1207 [570]	1151 [543]	1131 [534]	1085 [512]	1022 [482]	956 [451]
						RPM	794	833	872	897	948	976	1005	1038	1078	1112
						Watts	287	295	317	317	331	351	361	365	370	399
4.0 [14.07]	Tap 3	Tap 3	1350 CFM / 1850 CFM	12x9T Blower 3/4 HP [559] 3 Speed (Constant Torque)	Tap 2 Medium	CFM	1643 [775]	1609 [759]	1580 [746]	1560 [736]	1511 [713]	1494 [705]	1443 [681]	1404 [663]	1335 [630]	1244 [587]
						RPM	927	954	986	1001	1035	1052	1083	1111	1122	1133
						Watts	461	475	490	506	518	528	535	548	530	502
4.0 [14.07]	Tap 3	Tap 3	1350 CFM / 1850 CFM	12x9T Blower 3/4 HP [559] 3 Speed (Constant Torque)	Tap 1 Low	CFM	1467 [692]	1448 [683]	1404 [663]	1373 [648]	1339 [632]	1306 [616]	1250 [590]	1210 [571]	1164 [549]	1087 [513]
						RPM	826	855	884	910	939	969	1003	1030	1067	1108
						Watts	328	344	348	363	379	387	398	408	418	434
4.0 [14.07]	Tap 3	Tap 3	1350 CFM / 1850 CFM	12x9T Blower 3/4 HP [559] 3 Speed (Constant Torque)	Tap 2 Medium	CFM	1634 [771]	1595 [753]	1547 [730]	1530 [722]	1487 [702]	1462 [690]	1438 [679]	1378 [650]	1352 [638]	1298 [613]
						RPM	894	923	950	981	1000	1030	1051	1079	1106	1126
						Watts	432	446	451	468	479	490	508	510	520	520
4.0 [14.07]	Tap 3	Tap 3	1350 CFM / 1850 CFM	12x9T Blower 3/4 HP [559] 3 Speed (Constant Torque)	Tap 3 High	CFM	1941 [916]	1915 [904]	1878 [886]	1814 [856]	1773 [837]	1709 [807]	1655 [781]	1570 [741]	1488 [702]	1374 [648]
						RPM	1028	1047	1068	1091	1104	1113	1124	1136	1142	1147
						Watts	708	725	729	727	717	696	673	647	618	571

Notes: (1) Set 3-1/2 and 4 ton Cool to Tap 2 for AHRI rated performance. (2) Set 13 SEER 5 ton Cool to Tap 1 for AHRI rated performance. (3) Set 14 SEER 5 ton Cool to Tap 1 for AHRI rated performance.

[ ] Designates Metric Conversions



INTEGRATED AIR &amp; WATER



Air

Indoor Airflow Performance

RACA14 Series

## INDOOR AIRFLOW PERFORMANCE RACA14 - 460 VOLTS (continued)

Nominal Cooling Capacity Tons [kW]	Motor Speed from Factory		Manufacturer Recommended Cooling Airflow (Min/Max)	Blower Size/ Motor HP [W] & # of Speeds	Motor Speed / Tap	External Static Pressure - Inches W.C. [kPa] (Side Discharge-Dry Coil)															
	Cool	Heat				0.1 [.02]	0.2 [.05]	0.3 [.07]	0.4 [.10]	0.5 [.12]	0.6 [.15]	0.7 [.17]	0.8 [.20]	0.9 [.22]	1.0 [.25]						
5.0 [17.59]	Tap 3	Tap 3	1600 CFM / 2100 CFM	12x9R Blower 1 HP [746] 5 Speed (Constant Torque)	Tap 1 Low	CFM	1787 [843]	1746 [824]	1705 [805]	1680 [793]	1621 [765]	1607 [758]	1564 [738]	1530 [722]	1505 [710]	1424 [672]					
						RPM	950	970	1000	1012	1042	1055	1079	1108	1113	1130					
						Watts	525	538	545	579	571	596	615	610	631	626					
	Tap 3	Tap 3			Tap 3	1600 CFM / 2100 CFM	12x9R Blower 1 HP [746] 5 Speed (Constant Torque)	Tap 2 Medium	CFM	1954 [922]	1927 [909]	1889 [892]	1843 [870]	1808 [853]	1738 [820]	1671 [789]	1620 [765]	1543 [728]	1433 [676]		
									RPM	1030	1042	1061	1082	1100	1121	1130	1133	1138	1146		
									Watts	664	673	683	696	704	700	697	684	667	635		
	Tap 3	Tap 3			Tap 3			1600 CFM / 2100 CFM	12x9R Blower 1 HP [746] 5 Speed (Constant Torque)	Tap 3 High	CFM	2095 [989]	2045 [965]	1983 [936]	1905 [899]	1840 [868]	1792 [846]	1712 [808]	1641 [774]	1558 [735]	1397 [659]
											RPM	1103	1114	1114	1123	1125	1130	1139	1140	1144	1148
											Watts	829	841	832	803	785	770	749	710	685	633

Notes: (1) Set 3-1/2 and 4 ton Cool to Tap 2 for AHRI rated performance. (2) Set 13 SEER 5 ton Cool to Tap 1 for AHRI rated performance. (3) Set 14 SEER 5 ton Cool to Tap 1 for AHRI rated performance.

## DOWN DISCHARGE PRESSURE DROP (ADD TO EXTERNAL STATIC PRESSURE)

CFM [L/s]	800 [378]	1000 [472]	1200 [566]	1400 [661]	1600 [755]	1800 [849]	2000 [944]
Pressure Drop—Includes W.C. [kPa]	.02 [.005]	.05 [.012]	.07 [.017]	.1 [.025]	.12 [.030]	.15 [.037]	.17 [.042]

[ ] Designates Metric Conversions





Air

Indoor Airflow Performance  
RACA15 Series

## INDOOR AIRFLOW PERFORMANCE RACA15 - 208/230 VOLTS

Nominal Cooling Capacity Tons [kW]	Motor Speed from Factory		Manufacturer Recommended Cooling Airflow (Min/Max)	Blower Size/ Motor HP [W] & # of Speeds	Motor Speed / Tap	External Static Pressure - Inches W.C. [kPa] (Side Discharge-Dry Coil)											
	Cool	Heat				0.1 [.02]	0.2 [.05]	0.3 [.07]	0.4 [.10]	0.5 [.12]	0.6 [.15]	0.7 [.17]	0.8 [.20]	0.9 [.22]	1.0 [.25]		
2.0 [7.03]	Tap 3	Tap 3	700 CFM / 950 CFM	10X9 Blower 1/3 HP [249] 3 Speed (Constant Torque)	Tap 1 Low	CFM	917 [433]	865 [408]	826 [390]	771 [364]	730 [345]	677 [320]	628 [296]	596 [281]			
						RPM	772	810	860	905	945	985	1013	1052			
						Watts	142	149	159	164	175	177	180	189			
2.5 [8.79]	Tap 3	Tap 3	850 CFM / 1150 CFM	10X9 Blower 1/3 HP [249] 3 Speed (Constant Torque)	Tap 2 Medium	CFM	931 [439]	880 [415]	854 [403]	795 [375]	743 [351]	694 [328]	655 [309]	608 [287]			
						RPM	789	1425	874	921	965	1002	1041	1070	200		
						Watts	155	159	170	176	185	188	196	200			
3.0 [10.55]	Tap 3	Tap 3	1000 CFM / 1400 CFM	12x9T Blower 1/2 HP [372] 3 Speed (Constant Torque)	Tap 3 High	CFM	1005 [474]	956 [451]	916 [432]	878 [414]	808 [381]	778 [367]	734 [346]	698 [329]			
						RPM	822	872	907	954	998	1036	1070	1103			
						Watts	178	192	198	208	212	224	224	234			
3.5 [12.31]	Tap 3	Tap 3	1200 CFM / 1600 CFM	12x9T Blower 3/4 HP [559] 3 Speed (Constant Torque)	Tap 1 Low	CFM	917 [433]	865 [408]	826 [390]	771 [364]	730 [345]	677 [320]	628 [296]	596 [281]			
						RPM	772	810	860	905	945	985	1013	1052			
						Watts	142	149	159	164	175	177	180	189			
3.5 [12.31]	Tap 3	Tap 3	1200 CFM / 1600 CFM	12x9T Blower 3/4 HP [559] 3 Speed (Constant Torque)	Tap 2 Medium	CFM	1013 [478]	980 [463]	939 [443]	893 [421]	864 [408]	792 [374]	752 [355]	687 [324]			
						RPM	820	854	901	934	976	1022	1064	1097			
						Watts	171	177	187	190	202	207	217	222			
3.5 [12.31]	Tap 3	Tap 3	1200 CFM / 1600 CFM	12x9T Blower 3/4 HP [559] 3 Speed (Constant Torque)	Tap 3 High	CFM	1227 [579]	1180 [557]	1160 [547]	1123 [530]	1090 [514]	1054 [497]	1008 [476]	882 [416]			
						RPM	930	976	1006	1029	1065	1089	1124	1154			
						Watts	264	276	288	291	300	305	311	292			
3.5 [12.31]	Tap 3	Tap 3	1200 CFM / 1600 CFM	12x9T Blower 3/4 HP [559] 3 Speed (Constant Torque)	Tap 1 Low	CFM	1108 [523]	1081 [510]	1040 [491]	951 [449]	916 [432]	857 [404]	776 [366]	722 [341]			
						RPM	713	752	796	845	873	920	966	1001			
						Watts	188	199	213	222	229	241	252	261			
3.5 [12.31]	Tap 3	Tap 3	1200 CFM / 1600 CFM	12x9T Blower 3/4 HP [559] 3 Speed (Constant Torque)	Tap 2 Medium	CFM	1169 [552]	1115 [526]	1086 [513]	1047 [494]	983 [464]	931 [439]	855 [404]	784 [370]			
						RPM	749	803	819	856	901	938	985	1029			
						Watts	217	231	233	246	259	266	277	289			
3.5 [12.31]	Tap 3	Tap 3	1200 CFM / 1600 CFM	12x9T Blower 3/4 HP [559] 3 Speed (Constant Torque)	Tap 3 High	CFM	1434 [677]	1419 [670]	1387 [655]	1340 [632]	1310 [618]	1258 [594]	1198 [565]	1160 [547]	1085 [512]	930 [439]	
						RPM	866	882	920	944	981	1008	1051	1078	1106	1131	
						Watts	372	377	390	399	413	421	426	443	445	412	
3.5 [12.31]	Tap 3	Tap 3	1200 CFM / 1600 CFM	12x9T Blower 3/4 HP [559] 3 Speed (Constant Torque)	Tap 1 Low	CFM	1336 [631]	1312 [619]	1295 [611]	1241 [586]	1200 [566]	1161 [548]	1119 [528]	1072 [506]	1001 [472]	939 [443]	
						RPM	827	856	874	913	949	983	1013	1048	1092	1127	
						Watts	298	308	313	325	341	352	361	374	387	402	
3.5 [12.31]	Tap 3	Tap 3	1200 CFM / 1600 CFM	12x9T Blower 3/4 HP [559] 3 Speed (Constant Torque)	Tap 2 Medium	CFM	1336 [631]	1312 [619]	1295 [611]	1241 [586]	1200 [566]	1161 [548]	1119 [528]	1072 [506]	1001 [472]	939 [443]	
						RPM	827	856	874	913	949	983	1013	1048	1092	1127	
						Watts	298	308	313	325	341	352	361	374	387	402	
3.5 [12.31]	Tap 3	Tap 3	1200 CFM / 1600 CFM	12x9T Blower 3/4 HP [559] 3 Speed (Constant Torque)	Tap 3 High	CFM	1591 [751]	1563 [738]	1558 [735]	1519 [717]	1490 [703]	1458 [688]	1410 [665]	1363 [643]	1277 [603]	1122 [530]	
						RPM	949	981	999	1027	1051	1086	1109	1129	1140	1158	
						Watts	476	490	501	515	527	542	546	543	522	478	

Notes: (1) Set 2 through 4 ton Cool to Tap 2 for AHRI rated performance. (2) Set 5 ton 1st Stage Cool to Tap 1 for AHRI rated performance.

[ ] Designates Metric Conversions



INTEGRATED AIR &amp; WATER



# INDOOR AIRFLOW PERFORMANCE RACA15 - 208/230 VOLTS (continued)

Nominal Cooling Capacity Tons [kW]	Motor Speed from Factory		Manufacturer Recommended Cooling Airflow (Min/Max)	Blower Size/ Motor HP [W] & # of Speeds	Motor Speed / Tap	External Static Pressure - Inches W.C. [kPa]										
	Cool	Heat				0.1 [.02]	0.2 [.05]	0.3 [.07]	0.4 [.10]	0.5 [.12]	0.6 [.15]	0.7 [.17]	0.8 [.20]	0.9 [.22]	1.0 [.25]	
4.0 [14.07]	Tap 3	Tap 3	1350 CFM / 1850 CFM	12x9T Blower 3/4 HP [559] 3 Speed (Constant Torque)	Tap 1 Low	CFM	1467 [692]	1448 [683]	1404 [663]	1373 [648]	1339 [632]	1306 [616]	1250 [590]	1210 [571]	1164 [549]	1087 [513]
						RPM	826	855	884	910	939	969	1003	1030	1067	1108
						Watts	328	344	348	363	379	387	398	408	418	434
4.0 [14.07]	Tap 3	Tap 3	1350 CFM / 1850 CFM	12x9T Blower 3/4 HP [559] 3 Speed (Constant Torque)	Tap 2 Medium	CFM	1634 [771]	1595 [753]	1547 [730]	1530 [722]	1487 [702]	1462 [690]	1438 [679]	1378 [650]	1352 [638]	1298 [613]
						RPM	894	923	950	981	1000	1030	1051	1079	1106	1126
						Watts	432	446	451	468	479	490	508	510	520	520
4.0 [14.07]	Tap 3	Tap 3	1350 CFM / 1850 CFM	12x9T Blower 3/4 HP [559] 3 Speed (Constant Torque)	Tap 3 High	CFM	1941 [916]	1915 [904]	1878 [886]	1814 [856]	1773 [837]	1709 [807]	1655 [781]	1570 [741]	1488 [702]	1374 [648]
						RPM	1028	1047	1068	1091	1104	1113	1124	1136	1142	1147
						Watts	708	725	729	727	717	696	673	647	618	571
5.0 [17.59]	1st Stage Tap 2	Tap 1	1600 CFM / 2100 CFM	12x9R Blower 1 HP [746] 5 Speed (Constant Torque)	Tap 1 Heat / 1st Stg Cool Low Static	CFM	1233 [582]	1158 [547]	1136 [536]	1090 [514]	1039 [490]	969 [457]	902 [426]	847 [400]	791 [373]	752 [355]
						RPM	734	774	793	822	860	892	934	957	983	1011
						Watts	223	231	238	248	259	269	288	284	295	306
5.0 [17.59]	1st Stage Tap 2	Tap 1	1600 CFM / 2100 CFM	12x9R Blower 1 HP [746] 5 Speed (Constant Torque)	Tap 2 Heat / 1st Stg Cool High Static	CFM	1433 [676]	1407 [664]	1354 [639]	1329 [627]	1270 [599]	1235 [583]	1195 [564]	1137 [537]	1083 [511]	1030 [486]
						RPM	821	843	868	888	929	944	975	1004	1040	1065
						Watts	319	331	342	346	365	368	381	391	406	412
5.0 [17.59]	2nd Stage Tap 4	Tap 1	1600 CFM / 2100 CFM	12x9R Blower 1 HP [746] 5 Speed (Constant Torque)	Tap 3 Unused	CFM	1768 [834]	1730 [816]	1693 [799]	1626 [767]	1599 [755]	1558 [735]	1522 [718]	1503 [709]	1444 [681]	1399 [660]
						RPM	938	959	983	1011	1025	1052	1089	1090	1117	1134
						Watts	520	533	541	560	563	578	599	599	605	615
5.0 [17.59]	2nd Stage Tap 4	Tap 4	1600 CFM / 2100 CFM	12x9R Blower 1 HP [746] 5 Speed (Constant Torque)	Tap 4 2nd Stage Low Static Cool	CFM	1926 [909]	1890 [892]	1864 [880]	1822 [860]	1794 [847]	1758 [830]	1710 [807]	1670 [788]	1579 [745]	1493 [705]
						RPM	999	1014	1040	1061	1079	1096	1119	1128	1138	1144
						Watts	654	660	674	688	699	708	714	705	683	661
5.0 [17.59]	2nd Stage Tap 4	Tap 5	1600 CFM / 2100 CFM	12x9R Blower 1 HP [746] 5 Speed (Constant Torque)	Tap 5 2nd Stage High Static Cool	CFM	2096 [989]	2057 [971]	2003 [945]	1951 [921]	1890 [892]	1819 [858]	1756 [829]	1686 [796]	1610 [760]	1498 [707]
						RPM	1069	1092	1106	1116	1121	1129	1138	1140	1148	1154
						Watts	829	846	840	822	807	782	768	730	708	679

Notes: (1) Set 2 through 4 ton Cool to Tap 2 for AHRI rated performance. (2) Set 5 ton 1st Stage Cool to Tap 1 for AHRI rated performance.

DOWN DISCHARGE PRESSURE DROP (ADD TO EXTERNAL STATIC PRESSURE)			
CFM [L/s]	800 [378]	1000 [472]	1200 [566]
Pressure Drop—Includes W.C. [kPa]	.02 [.005]	.05 [.012]	.07 [.017]
	1400 [661]	1600 [755]	2000 [944]
	.1 [.025]	.12 [.030]	.17 [.042]

[ ] Designates Metric Conversions



<b>ELECTRICAL DATA – RACA14 SERIES</b>						
		<b>024AJD***AA</b>	<b>030AJD***AA</b>	<b>036ACD***AA</b>	<b>036AJD***AA</b>	<b>042ACT***AA</b>
<b>Unit Information</b>	Unit Operating Voltage Range	187-253	187-253	187-253	187-253	187-253
	Volts	208/230	208/230	208/230	208/230	208/230
	Phase	1	1	3	1	3
	Hz	60	60	60	60	60
	Minimum Circuit Ampacity	17	20	16	22	24
	Minimum Overcurrent Protection Device Size	20	20	20	25	25
	Maximum Overcurrent Protection Device Size	25	30	20	35	35
<b>Compressor Motor</b>	No.	1	1	1	1	1
	Volts	208/230	208/230	208/230	208/230	208/230
	Phase	1	1	3	1	3
	RPM	3450	3450	3450	3450	3450
	HP, Compressor 1	2 1/6	2 2/3	3 1/3	3 1/3	3 1/2
	Amps (RLA), Comp. 1	11.2	12.8	9	14.1	13.2
	Amps (LRA), Comp. 1	60.8	64	71	77	88
<b>Condenser Motor</b>	No.	1	1	1	1	1
	Volts	208/230	208/230	208/230	208/230	208/230
	Phase	1	1	1	1	1
	HP	1/3	1/3	1/3	1/3	1/3
	Amps (FLA, each)	1.5	1.5	1.5	1.5	1.5
	Amps (LRA, each)	3	3	3	3	3
<b>Evaporator Fan</b>	No.	1	1	1	1	1
	Volts	208/230	208/230	208/230	208/230	208/230
	Phase	1	1	1	1	1
	HP	1/4	1/2	1/2	1/2	3/4
	Amps (FLA, each)	1.3	2.4	2.5	2.5	6
	Amps (LRA, each)	2.3	5.1	4.6	4.6	

1. Horsepower Per Compressor.
2. Amp Draw Per Motor. Multiply Value By Number of Motors to Determine Total Amps.



ELECTRICAL DATA – RACA14 SERIES						
		042AJT***AA	048ACT***AA	048AJT***AA	060ACT***AA	060AJT***AA
Unit Information	Unit Operating Voltage Range	187-253	187-253	187-253	197-253	197-253
	Volts	208/230	208/230	208/230	208/230	208/230
	Phase	1	3	1	3	1
	Hz	60	60	60	60	60
	Minimum Circuit Ampacity	30	25	33	32	41
	Minimum Overcurrent Protection Device Size	30	25	35	35	45
	Maximum Overcurrent Protection Device Size	45	35	50	45	60
Compressor Motor	No.	1	1	1	1	1
	Volts	208/230	208/230	208/230	208/230	208/230
	Phase	1	3	1	3	1
	RPM	3450	3450	3450	3500	3500
	HP, Compressor 1	3 1/2	4	4	5	5
	Amps (RLA), Comp. 1	17.9	13.1	19.9	17.8	24.4
	Amps (LRA), Comp. 1	112	83.1	109	110	144.2
Condenser Motor	No.	1	1	1	1	1
	Volts	208/230	208/230	208/230	208/230	208/230
	Phase	1	1	1	1	1
	HP	1/3	1/3	1/3	1/3	1/3
	Amps (FLA, each)	1.5	2	2	2	2
	Amps (LRA, each)	3	3.9	3.9	3.9	3.9
Evaporator Fan	No.	1	1	1	1	1
	Volts	208/230	208/230	208/230	208/230	208/230
	Phase	1	1	1	1	1
	HP	3/4	3/4	3/4	1	1
	Amps (FLA, each)	6	6	6	7.6	7.6
	Amps (LRA, each)					

1. Horsepower Per Compressor.
2. Amp Draw Per Motor. Multiply Value By Number of Motors to Determine Total Amps.



<b>ELECTRICAL DATA – RACA15 SERIES</b>						
		<b>024AJT***AA</b>	<b>030AJT***AA</b>	<b>036ACT***AA</b>	<b>036AJT***AA</b>	<b>042ACT***AA</b>
<b>Unit Information</b>	Unit Operating Voltage Range	187-253	187-253	187-253	187-253	187-253
	Volts	208/230	208/230	208/230	208/230	208/230
	Phase	1	1	3	1	3
	Hz	60	60	60	60	60
	Minimum Circuit Ampacity	19	21	17	24	24
	Minimum Overcurrent Protection Device Size	20	25	20	25	25
	Maximum Overcurrent Protection Device Size	25	30	25	35	35
<b>Compressor Motor</b>	No.	1	1	1	1	1
	Volts	208/230	208/230	208/230	208/230	208/230
	Phase	1	1	3	1	3
	RPM	3450	3450	3450	3450	3450
	HP, Compressor 1	2 1/6	2 2/3	3 1/3	3 1/3	3 1/2
	Amps (RLA), Comp. 1	11.2	12.8	9	14.1	13.2
	Amps (LRA), Comp. 1	60.8	64	71	77	88
<b>Condenser Motor</b>	No.	1	1	1	1	1
	Volts	208/230	208/230	208/230	208/230	208/230
	Phase	1	1	1	1	1
	HP	1/3	1/3	1/3	1/3	1/3
	Amps (FLA, each)	1.5	1.5	1.5	1.5	1.5
	Amps (LRA, each)	3	3	3	3	3
<b>Evaporator Fan</b>	No.	1	1	1	1	1
	Volts	208/230	208/230	208/230	208/230	208/230
	Phase	1	1	1	1	1
	HP	1/3	1/2	1/2	1/2	3/4
	Amps (FLA, each)	2.8	2.8	4.1	4.1	6
	Amps (LRA, each)					

1. Horsepower Per Compressor.
2. Amp Draw Per Motor. Multiply Value By Number of Motors to Determine Total Amps.



### ELECTRICAL DATA – RACA15 SERIES

		042AJT***AA	048ACT***AA	048AJT***AA	060ACT***AA	060AJT***AA
Unit Information	Unit Operating Voltage Range	187-253	187-253	187-253	197-253	197-253
	Volts	208/230	208/230	208/230	208/230	208/230
	Phase	1	3	1	3	1
	Hz	60	60	60	60	60
	Minimum Circuit Ampacity	30	25	33	30	46
	Minimum Overcurrent Protection Device Size	30	25	35	50	50
	Maximum Overcurrent Protection Device Size	45	35	50	45	70
Compressor Motor	No.	1	1	1	1	1
	Volts	208/230	208/230	208/230	208/230	208/230
	Phase	1	3	1	3	1
	RPM	3450	3450	3450	3450	3450
	HP, Compressor 1	3 1/2	4	4	5	5
	Amps (RLA), Comp. 1	17.9	13.1	19.9	16.2	28.8
	Amps (LRA), Comp. 1	112	83.1	109	110	152.9
Condenser Motor	No.	1	1	1	1	1
	Volts	208/230	208/230	208/230	208/230	208/230
	Phase	1	1	1	1	1
	HP	1/3	1/3	1/3	1/3	1/3
	Amps (FLA, each)	1.5	2	2	2	2
	Amps (LRA, each)	3	3.9	3.9	3.9	3.9
Evaporator Fan	No.	1	1	1	1	1
	Volts	208/230	208/230	208/230	208/230	208/230
	Phase	1	1	1	1	1
	HP	3/4	3/4	3/4	1	1
	Amps (FLA, each)	6	6	6	7.6	7.6
	Amps (LRA, each)					

1. Horsepower Per Compressor.
2. Amp Draw Per Motor. Multiply Value By Number of Motors to Determine Total Amps.

### Copper Wire Size – AWG (1% Voltage Drop)

SUPPLY WIRE LENGTH- FEET	CIRCUIT AMPACITY																						
	15	20	25	30	35	40	45	50	55	60	65	70	75	80	85	90	95	100	105	110	115	120	125
300	4	3	2	2	1	1/0	1/0	2/0	2/0	3/0	3/0	3/0	4/0	4/0	4/0	4/0	250	250	250	250	300	300	300
250	4	4	3	3	2	1	1	1/0	1/0	2/0	2/0	2/0	3/0	3/0	3/0	4/0	4/0	4/0	4/0	4/0	250	250	250
200	6	4	4	4	3	2	2	1	1	1/0	1/0	1/0	2/0	2/0	2/0	3/0	3/0	3/0	3/0	3/0	4/0	4/0	4/0
150	8	6	6	4	4	4	3	3	2	2	1	1	1/0	1/0	1/0	2/0	2/0	2/0	2/0	2/0	2/0	3/0	3/0
100	10	8	8	6	6	6	4	4	4	3	3	2	2	2	1	1	1	1	1	1/0	1/0	1/0	1/0
50	14	12	10	10	8	8	6	6	6	4	4	4	3	3	3	2	2	2	2	2	1	1	1

- Notes: 1. Wire size based on 60°C. type copper conductors below 100 ampacity. 2. Wire size based on 75°C. type copper conductors for 100 ampacity and above.



208/240 VOLT, SINGLE PHASE, 60 HZ, AUXILIARY ELECTRIC HEATER KITS CHARACTERISTICS AND APPLICATION																		
Single Power Supply for Both Unit and Heater Kit							Separate Power Supply for Both Unit and Heater Kit											
Model No. RACA-	RXQJ-Heater Kit Nominal kW	No. of Sequence Steps	Heater Kit				Air Conditioner				Heater Kit				Air Conditioner			
			Rated Heater kW @ 208/240V	Heater kBTU/Hr @ 208/240V	Heater Amp @ 208/240V	Unit Min. Ampacity @ 208/240V	Over Current Protective Device Size		Min. Ckt. Ampacity 208/240V	Max. Fuse Size 208/240V	Min. Circuit Ampacity 208/240V	Over Current Protective Device Size						
							Min./Max. @ 208V	Min./Max. @ 240V				Min./Max. @ 208V	Min./Max. @ 240V					
14024AJD***AA	No Heat A05J A10J	1 1	— 3.6/4.8 7.2/9.6	— 12.28/16.38 24.57/32.76	— 17.3/20.0 34.6/40.0	17/17 24/27 45/52	20/25 25/25 45/45	20/25 30/30 60/60	— 22/25 44/50	— 25/25 45/50	17/17 17/17 17/17	20/25 20/25 20/25	20/25 20/25 20/25					
14030AJD***AA	No Heat A05J A10J	1 1	3.6/4.8 7.2/9.6	12.28/16.38 24.57/32.76	17.3/20.0 34.6/40.0	20/20 25/28 47/53	20/30 25/25 50/50	20/30 30/30 60/60	— 22/25 44/50	— 25/25 45/50	20/20 20/20 20/20	20/30 20/30 20/30	20/30 20/30 20/30					
14036AJD***AA	No Heat A05J A10J A15J	1 1 1	3.6/4.8 7.2/9.6 10.8/14.4	12.28/16.38 24.57/32.76 36.85/49.13	17.3/20.0 34.6/40.0 51.9/60.0	22/22 25/29 47/54 68/79	25/35 30/30 50/50 70/70	25/35 30/30 60/60 80/80	— 22/25 44/50 65/75	— 25/25 45/50 70/80	22/22 22/22 22/22 22/22	25/35 25/35 25/35 25/35	25/35 25/35 25/35 25/35					
14042AJT***AA	No Heat A05J B10J B15J	— 1 1 1	— 3.6/4.8 7.2/9.6 10.8/14.4	— 12.28/16.38 24.57/32.76 36.85/49.13	— 17.3/20.0 34.6/40.0 51.9/60.0	30/30 30/33 51/58 73/83	30/45 30/30 60/60 80/80	30/45 35/35 60/60 90/90	— 22/25 44/50 65/75	— 25/25 45/50 70/80	30/30 30/30 30/30 30/30	30/45 30/45 30/45 30/45	30/45 30/45 30/45 30/45					
14048AJT***AA	No Heat A05J B10J B15J	— 1 1 1	— 3.6/4.8 7.2/9.6 10.8/14.4	— 12.28/16.38 24.57/32.76 36.85/49.13	— 17.3/20.0 34.6/40.0 51.9/60.0	33/33 33/33 51/58 73/83	35/50 35/35 60/60 80/80	35/50 35/35 60/60 90/90	— 22/25 44/50 65/75	— 25/25 45/50 70/80	33/33 33/33 33/33 33/33	35/50 35/50 35/50 35/50	35/50 35/50 35/50 35/50					
14060AJT***AA	No Heat A05J B10J B15J	— 1 1 1	— 3.6/4.8 7.2/9.6 10.8/14.4	— 12.28/16.38 24.57/32.76 36.85/49.13	— 17.3/20.0 34.6/40.0 51.9/60.0	41/41 41/41 53/60 75/85	45/60 45/45 60/60 80/80	45/60 45/45 60/60 90/90	— 22/25 44/50 65/75	— 25/25 45/50 70/80	41/41 41/41 41/41 41/41	45/60 45/60 45/60 45/60	45/60 45/60 45/60 45/60					

208/240 VOLT, THREE PHASE, 60 HZ, AUXILIARY ELECTRIC HEATER KITS CHARACTERISTICS AND APPLICATION																		
Single Power Supply for Both Unit and Heater Kit							Separate Power Supply for Both Unit and Heater Kit											
Model No. RACA-	RXQJ-Heater Kit Nominal kW	No. of Sequence Steps	Heater Kit				Air Conditioner				Heater Kit				Air Conditioner			
			Rated Heater kW @ 208/240V	Heater kBTU/Hr @ 208/240V	Heater Amp @ 208/240V	Unit Min. Ampacity @ 208/240V	Over Current Protective Device Size		Min. Ckt. Ampacity 208/240V	Max. Fuse Size 208/240V	Min. Circuit Ampacity 208/240V	Over Current Protective Device Size						
							Min./Max. @ 208V	Min./Max. @ 240V				Min./Max. @ 208V	Min./Max. @ 240V					
14036ACD***AA	No Heat A10C A15C	— 1 1	— 7.2/9.6 10.8/14.4	— 24.57/32.76 36.85/49.13	— 20.0/23.1 30.1/34.7	16/16 29/32 41/47	20/20 30/30 45/45	20/20 35/35 50/50	— 25/29 38/44	— 25/30 40/45	16/16 16/16 16/16	20/20 20/20 20/20	20/20 20/20 20/20					
14042ACT***AA	No Heat A10C A15C	— 1 1	— 7.2/9.6 10.8/14.4	— 24.57/32.76 36.85/49.13	— 20.0/23.1 30.1/34.7	24/24 33/37 46/51	25/35 35/35 50/50	25/35 40/40 60/60	— 25/29 38/44	— 25/30 40/45	24/24 24/24 24/24	25/35 25/35 25/35	25/35 25/35 25/35					
14048ACT***AA	No Heat A10C A15C	— 1 1	— 7.2/9.6 10.8/14.4	— 24.57/32.76 36.85/49.13	— 20.0/23.1 30.1/34.7	25/25 33/37 46/51	25/35 35/35 50/50	25/35 40/40 60/60	— 25/29 38/44	— 25/30 40/45	25/25 25/25 25/25	25/35 25/35 25/35	25/35 25/35 25/35					
14060ACT***AA	No Heat A10C A15C	— 1 1	— 7.2/9.6 10.8/14.4	— 24.57/32.76 36.85/49.13	— 20.0/23.1 30.1/34.7	32/32 35/39 48/53	35/45 35/35 50/50	35/45 40/40 60/60	— 25/29 38/44	— 25/30 40/45	32/32 32/32 32/32	35/45 35/45 35/45	35/45 35/45 35/45					

208/240 VOLT, SINGLE PHASE, 60 HZ, AUXILIARY ELECTRIC HEATER KITS CHARACTERISTICS AND APPLICATION												
Single Power Supply for Both Unit and Heater Kit						Separate Power Supply for Both Unit and Heater Kit						
Model No. RACA-	RXQJ- Heater Kit Nominal kW	No. of Sequence Steps	Rated Heater kW @ 208/240V	Heater kBTU/Hr @ 208/240V	Heater Amp @ 208/240V	Heater Kit			Air Conditioner			
						Unit Min. Ampacity @ 208/240V	Min. Ckt. Ampacity @ 208/240V	Over Current Protective Device Size Min./Max. @ 240V	Min. Ckt. Ampacity @ 208/240V	Max. Fuse Size @ 208/240V	Min. Circuit Ampacity @ 208/240V	Over Current Protective Device Size Min./Max. @ 208V
15024AJT***AA	No Heat	—	—	—	—	19/19	—	—	19/19	—	19/19	20/25
	A05J	1	3.6/4.8	12.28/16.38	17.3/20.0	26/29	22/25	25/25	19/19	25/25	20/25	20/25
	A10J	1	7.2/9.6	24.57/32.76	34.6/40.0	47/54	44/50	45/50	19/19	45/50	20/25	20/25
15030AJT***AA	No Heat	—	—	—	—	21/21	—	—	21/21	—	21/21	25/30
	A05J	1	3.6/4.8	12.28/16.38	17.3/20.0	26/29	22/25	25/25	21/21	25/30	25/30	25/30
	A10J	1	7.2/9.6	24.57/32.76	34.6/40.0	47/54	44/50	45/50	21/21	45/50	25/30	25/30
15036AJT***AA	No Heat	—	—	—	—	24/24	—	—	24/24	—	24/24	25/35
	A05J	1	3.6/4.8	12.28/16.38	17.3/20.0	27/31	22/25	25/25	24/24	25/35	25/35	25/35
	A10J	1	7.2/9.6	24.57/32.76	34.6/40.0	49/56	44/50	45/50	24/24	45/50	25/35	25/35
15042AJT***AA	No Heat	—	—	—	—	70/70	—	—	70/70	—	70/80	25/35
	A05J	1	3.6/4.8	12.28/16.38	17.3/20.0	30/33	22/25	25/25	30/30	30/45	30/45	30/45
	B10J	1	7.2/9.6	24.57/32.76	34.6/40.0	51/58	44/50	45/50	30/30	45/50	30/45	30/45
15048AJT***AA	No Heat	—	—	—	—	80/80	—	—	80/80	—	70/80	30/45
	A05J	1	3.6/4.8	12.28/16.38	17.3/20.0	33/33	22/25	25/25	33/33	35/50	35/50	35/50
	B10J	1	7.2/9.6	24.57/32.76	34.6/40.0	51/58	44/50	45/50	33/33	45/50	35/50	35/50
15060AJT***AA	No Heat	—	—	—	—	80/80	—	—	80/80	—	70/80	35/50
	A05J	1	3.6/4.8	12.28/16.38	17.3/20.0	46/46	22/25	25/25	46/46	50/70	50/70	50/70
	B10J	1	7.2/9.6	24.57/32.76	34.6/40.0	60/60	44/50	45/50	46/46	46/46	50/70	50/70

208/240 VOLT, THREE PHASE, 60 HZ, AUXILIARY ELECTRIC HEATER KITS CHARACTERISTICS AND APPLICATION												
Single Power Supply for Both Unit and Heater Kit						Separate Power Supply for Both Unit and Heater Kit						
Model No. RACA-	RXQJ- Heater Kit Nominal kW	No. of Sequence Steps	Rated Heater kW @ 208/240V	Heater kBTU/Hr @ 208/240V	Heater Amp @ 208/240V	Heater Kit			Air Conditioner			
						Unit Min. Ampacity @ 208/240V	Min. Ckt. Ampacity @ 208/240V	Over Current Protective Device Size Min./Max. @ 240V	Min. Ckt. Ampacity @ 208/240V	Max. Fuse Size @ 208/240V	Min. Circuit Ampacity @ 208/240V	Over Current Protective Device Size Min./Max. @ 208V
15036ACT***AA	No Heat	—	—	—	—	17/17	—	—	17/17	—	17/17	20/25
	A10C	1	7.2/9.6	24.57/32.76	20.0/23.1	31/34	25/29	25/30	17/17	25/30	20/25	20/25
	A15C	1	10.8/14.4	36.85/49.13	30.1/34.7	43/49	38/44	40/45	17/17	40/45	20/25	20/25
15042ACT***AA	No Heat	—	—	—	—	24/24	—	—	24/24	—	24/24	25/35
	A10C	1	7.2/9.6	24.57/32.76	20.0/23.1	33/37	25/29	25/30	24/24	25/35	25/35	25/35
	A15C	1	10.8/14.4	36.85/49.13	30.1/34.7	46/51	38/44	40/45	24/24	40/45	25/35	25/35
15048ACT***AA	No Heat	—	—	—	—	25/25	—	—	25/25	—	25/25	25/35
	A10C	1	7.2/9.6	24.57/32.76	20.0/23.1	33/37	25/29	25/30	25/25	25/30	25/35	25/35
	A15C	1	10.8/14.4	36.85/49.13	30.1/34.7	46/51	38/44	40/45	25/25	40/45	25/35	25/35
15060ACT***AA	No Heat	—	—	—	—	30/30	—	—	30/30	—	30/30	50/45
	A10C	1	7.2/9.6	24.57/32.76	20.0/23.1	35/39	25/29	25/30	30/30	25/30	50/45	50/45
	A15C	1	10.8/14.4	36.85/49.13	30.1/34.7	48/53	38/44	40/45	30/30	40/45	50/45	50/45



# UNIT DIMENSIONS PACKAGE AIR CONDITIONERS

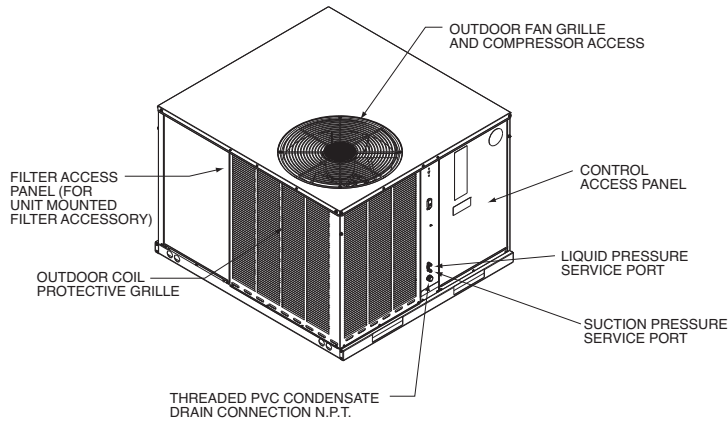

IMPORTANT: UNIT MUST BE LEVEL TO PREVENT WATER MIGRATION

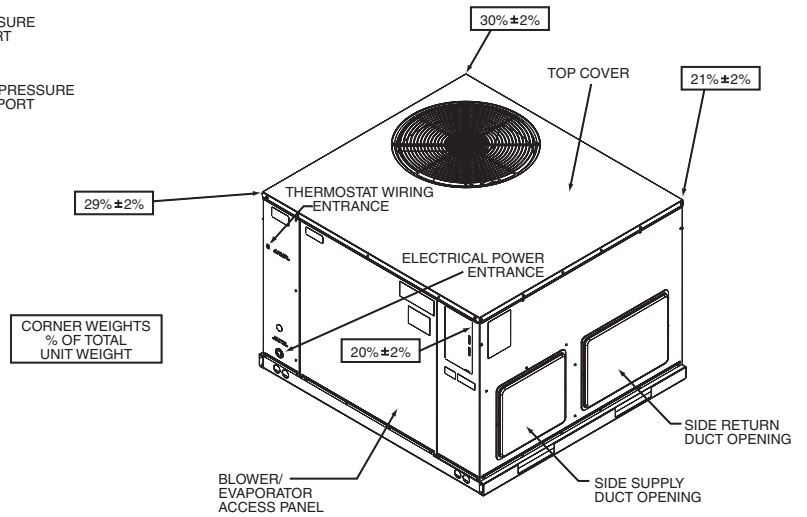

## TOP VIEW

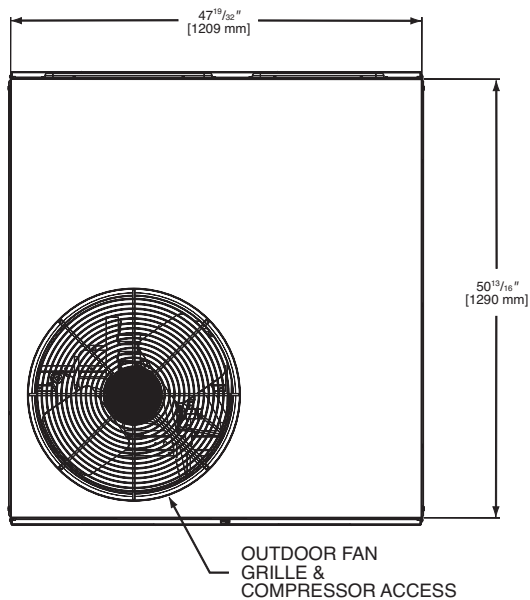

## BOTTOM VIEW

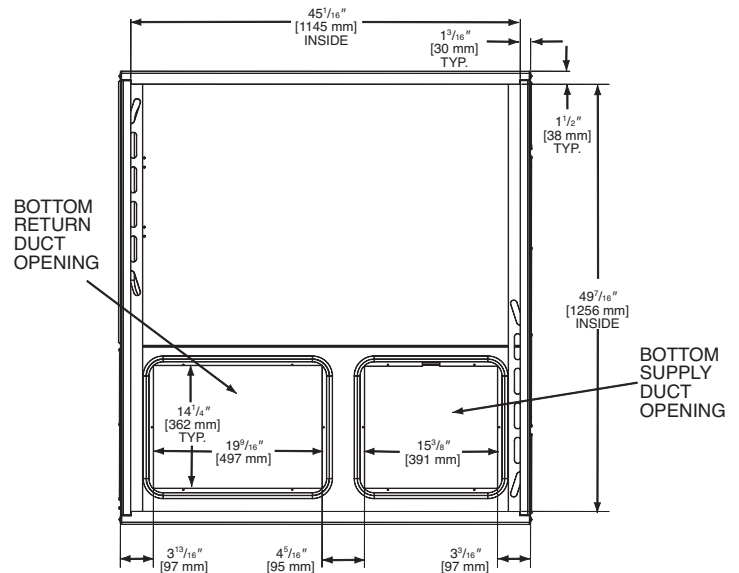

[ ] Designates Metric Conversions

### SIDE VIEW

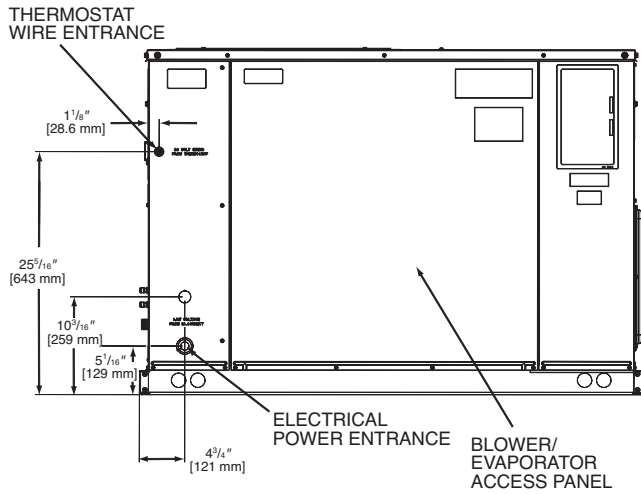

### SIDE VIEW

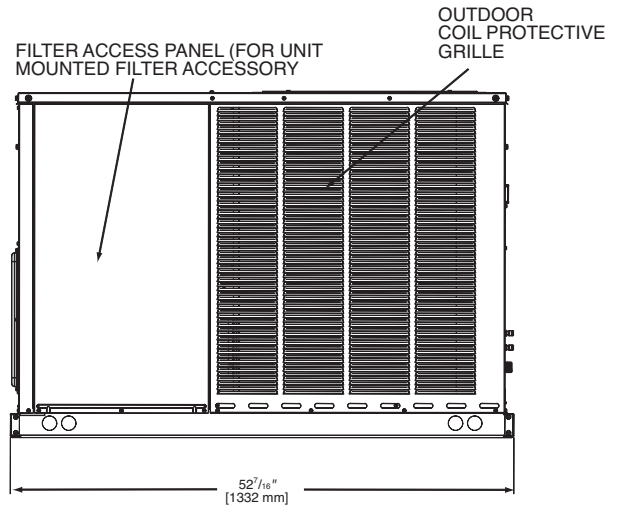

### FRONT VIEW

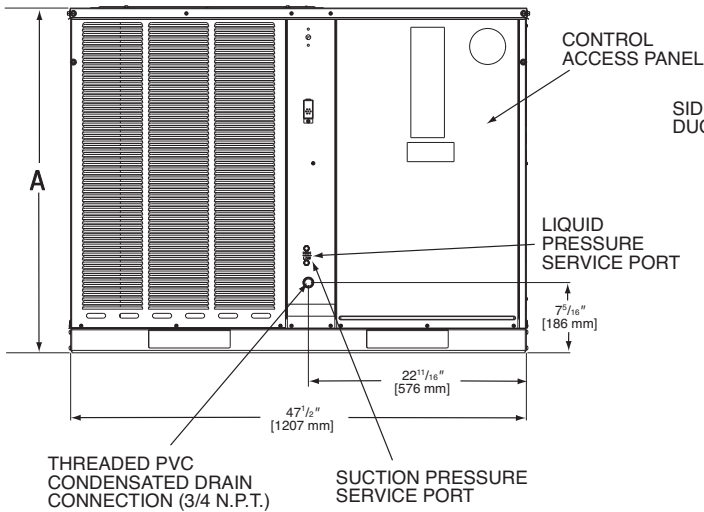

### REAR VIEW

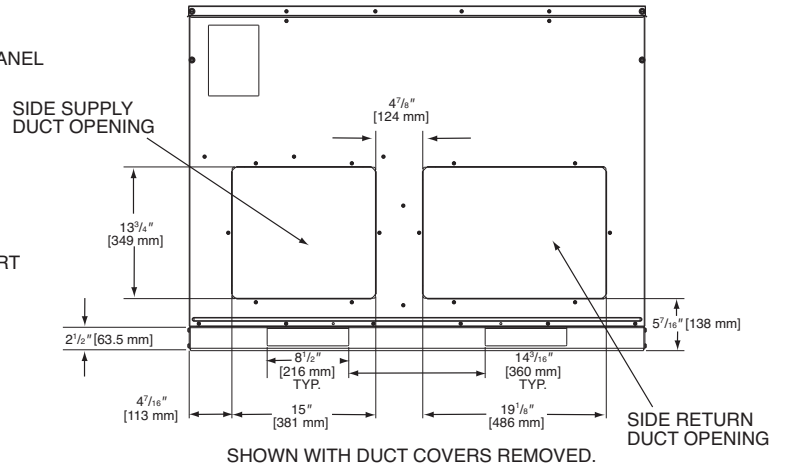

[ ] Designates Metric Conversions

Model #	Height "A"
024, 030, 036, 042	35 <sup>15</sup> / <sub>16</sub>
048, 060	41

**IMPORTANT:**  
Unit must be level to prevent water migration.

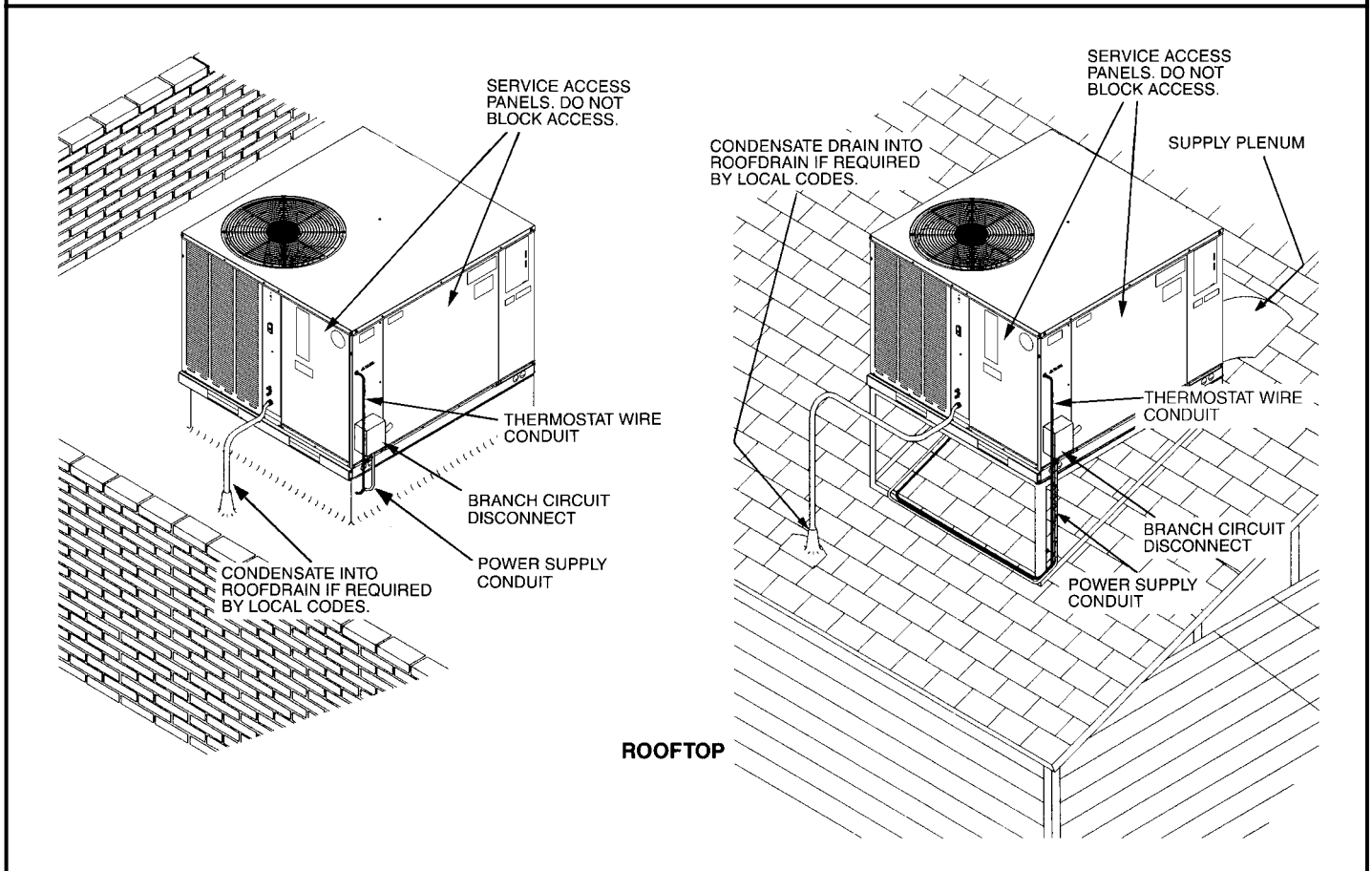
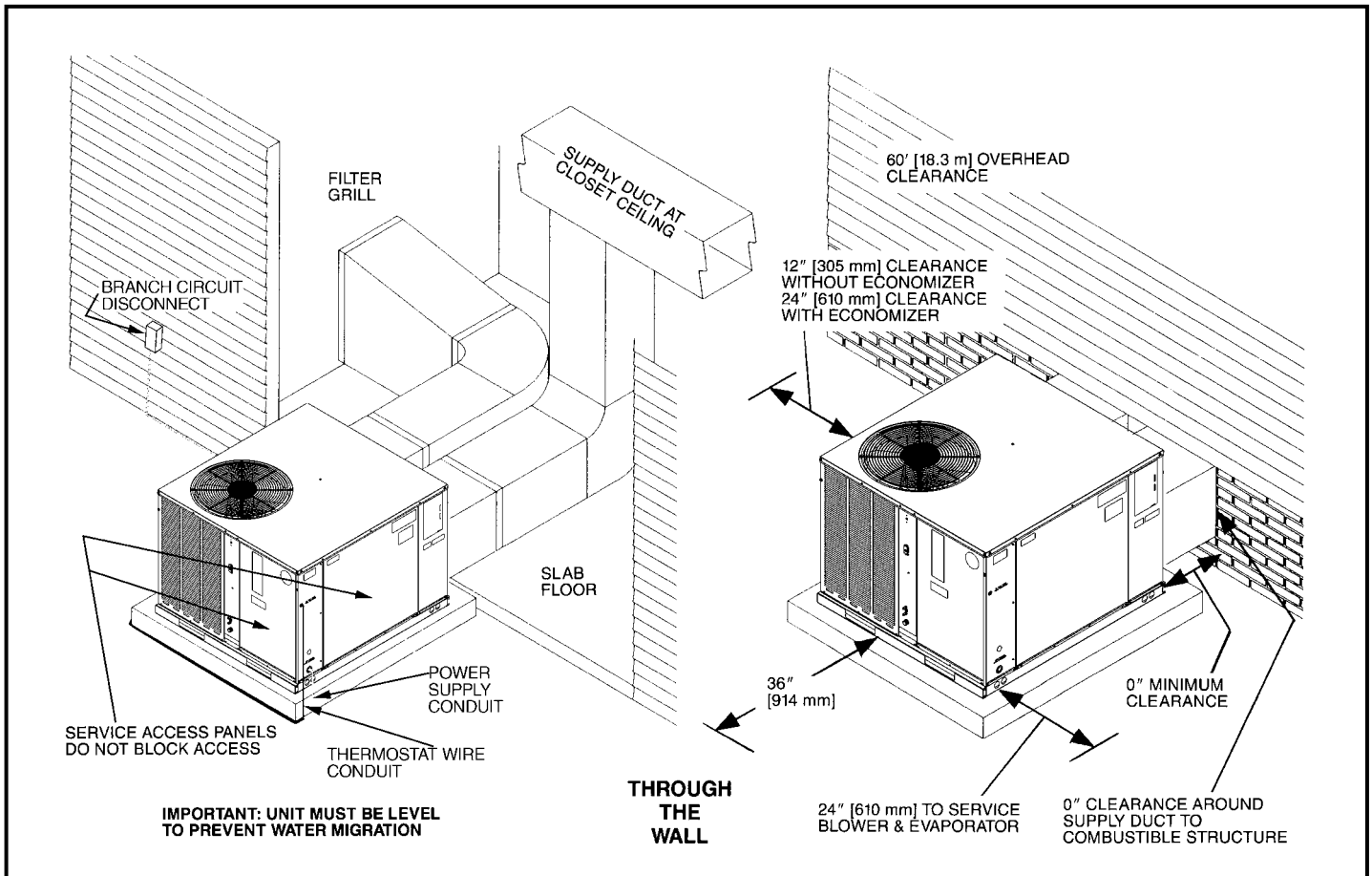

[ ] Designates Metric Conversions

## ACCESSORY EQUIPMENT

Accessory Description	Model Application	Accessory Model No.
Thermostats	RACA14/15	See Thermostat Specification Sheet (T11-001)
Roofcurbs	RACA14/15	RXSG-AAA08 (8" [203 mm] Height) RXSG-AAA14 (14" [356 mm] Height) RXSG-AAA24 (24" [610 mm] Height)
Supply & Return Diffusers	RACA14/15	RXRN-BD15
Economizers (Sideflow ONLY)	RACA14/15	AXRE-CCA30 (3 Position) AXRD-CCM10 (Fully Modulating)
Economizers (Downflow ONLY)	RACA14/15	AXRE-CAA30 (3 Position) AXRD-CAM10 (Fully Modulating)
Fresh Air Damper	RACA14/15	AXRF-FAB1 (Motorized-35%) AXRF-FAA1 (Fixed-35%)
Rectangular to Round Transition (Downflow)	RACA14/15	RXMC-CA02 (16" [406 mm] Ducts) RXMC-CA03 (18" [457 mm] Ducts)
Filter Kit	RACA14/15	RXRy-B01
Sideflow Rectangular to Round Transition	RACA14/15	AXMC-BA01
Low Ambient Control	RACA14/15	RXRZ-B01
High Pressure Control ①	RACA14/15	RXAB-E01
Low Pressure Control ②	RACA14/15	RXAC-C01

① High pressure switch standard on RACA (13/14/15) 060  
② Low pressure switch standard on RACA 15 060.

[ ] Designates Metric Conversions

## COMMON SUPPLY/RETURN CONCENTRIC AIR DIFFUSER

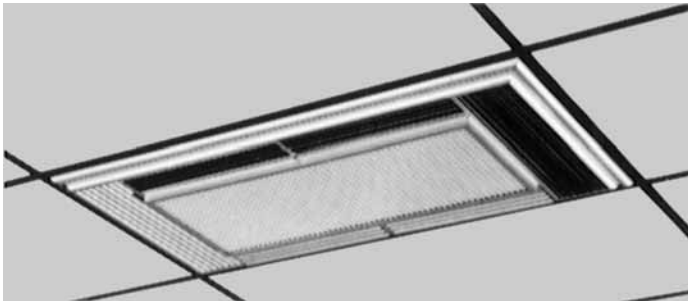

DIFFUSER INSTALLS FLUSH WITH CEILING

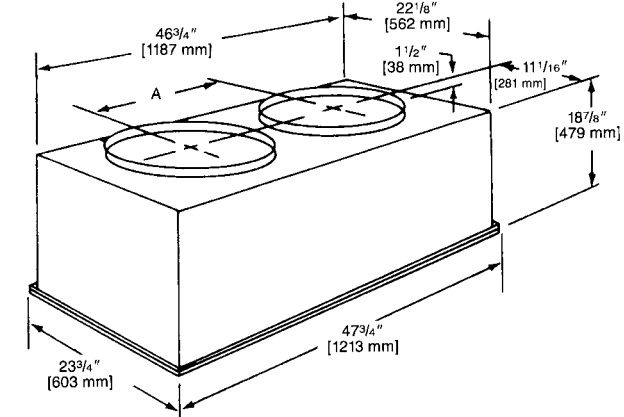

## SUPPLY/RETURN DIFFUSER

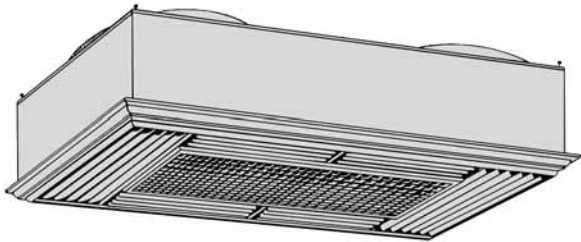

Designed to convert a side by side or an over and under arrangement into a concentric distribution of air. The diffuser is flush mounted, completely insulated, assembled, and internally baffled to provide four way supply air distribution with a center return. To make the assembly complete and ready to fit into a 2' [0.61 m] x 4' [1.22 m] suspended ceiling grid, the diffuser includes adjustable supply louvers, hanging rings, anti-sweat gasket, and round flanges for use with flexible ducts.

**NOTE:** The location of the combination supply and return diffuser should not exceed 10 feet [3.05 m] above the floor level for units @ 1000 CFM [472 L/s] or less and 12 [3.66 m] to 14 feet [4.27 m] above the floor level for units with CFM greater than 1000 [472 L/s]. If the diffuser is installed with a greater distance than recommended above, the supply air may become stratified above the required comfort area causing uncomfortable conditions.

## AIRFLOW/PRESSURE DROP INFORMATION (INCHES W.C. [kPa])

Accessory	Approximate CFM [L/s]-Supply Air			
	1300 [614]	1575 [743]	1800 [850]	2200 [1038]
Plenum & Supply/Return Duct	.07 [.017]	.10 [.024]	.12 [.030]	.17 [.042]
Diffuser	.09 [.022]	.13 [.032]	.16 [.040]	.24 [.060]
Economizer	.06 [.015]	.09 [.022]	.11 [.027]	.17 [.042]

## SUPPLY AIR/PERFORMANCE

Diffuser Airflow CFM [L/s]	Range of Throw Ft. [m]
800 [378]-1200 [566]	14 [4.27]-16 [4.88]
1600 [755]-2000 [944]	18 [5.49]-28 [8.53]

Model No.	Diameter Inches [mm]	Shipping Wt. Lbs. [kg]	Dimension A Inches [mm]
RXRN-BD15	16 [406]	90 [40.82]	20 1/2 [521]

# FILTER KIT INSTALLATION RXRY-B01

For use in either vertical  
or horizontal discharge.

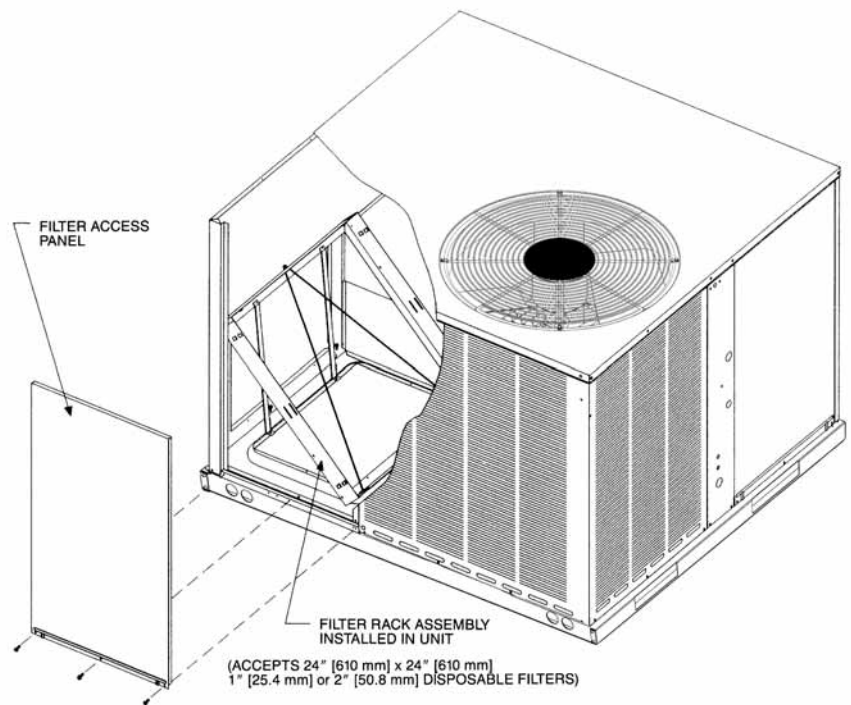

Airflow Pressure Drop, Inches W.C. [kPa]		
CFM [L/s]	1" Filter	2" Filter
500 [236]	.02 [.0050]	.03 [.0075]
600 [283]	.02 [.0050]	.03 [.0075]
700 [330]	.03 [.0075]	.04 [.0101]
800 [378]	.04 [.0101]	.05 [.0124]
900 [425]	.05 [.0124]	.06 [.0149]
1000 [472]	.07 [.0174]	.08 [.0199]
1100 [519]	.08 [.0199]	.09 [.0224]
1200 [566]	.10 [.0249]	.12 [.0299]
1300 [614]	.13 [.0324]	.15 [.0373]
1400 [661]	.16 [.0398]	.19 [.0473]
1500 [708]	.19 [.0473]	.21 [.0523]
1600 [755]	.20 [.0498]	.23 [.0572]
1700 [802]	.21 [.0523]	.24 [.0598]
1800 [850]	.22 [.0548]	.25 [.0623]
1900 [897]	.24 [.0598]	.27 [.0672]
2000 [944]	.26 [.0647]	.29 [.0722]

[ ] Designates Metric Conversions

# DUCT ADAPTERS RECTANGULAR TO ROUND TRANSITIONS (DOWNFLOW)

**RXMC-CA02**

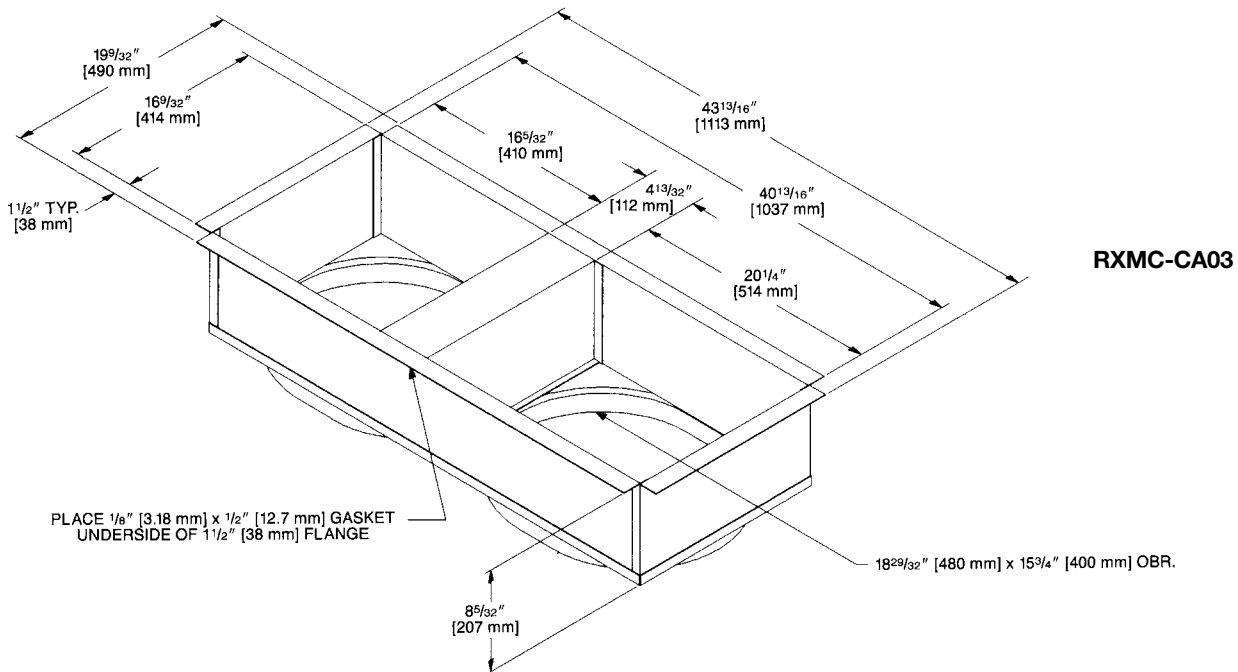
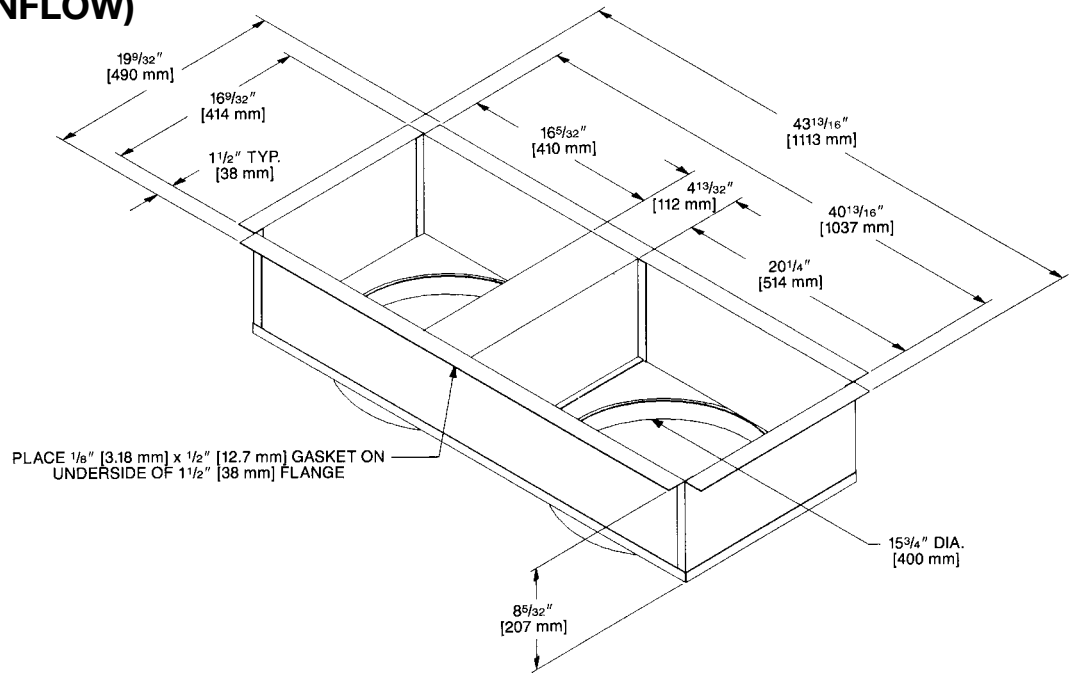

[ ] Designates Metric Conversions

## FRESH AIR DAMPER FOR USE ON RACA14- SERIES

### AXRF-FAA1 (Fixed - 0-35%)

The 0-35% manual outside Air Damper is designed to replace the unit return air duct cover. No drilling or damper assembly is required. The amount of outside air (0-35%) is controlled by simply adjusting the side damper.

### AXRF-FAB1 (Motorized - 0-35%)

The 0-35% motorized outside Air Damper is designed to replace the unit return air duct cover. No drilling or damper assembly is required. The control motor opens the adjustable slide damper when the unit blower motor is energized.

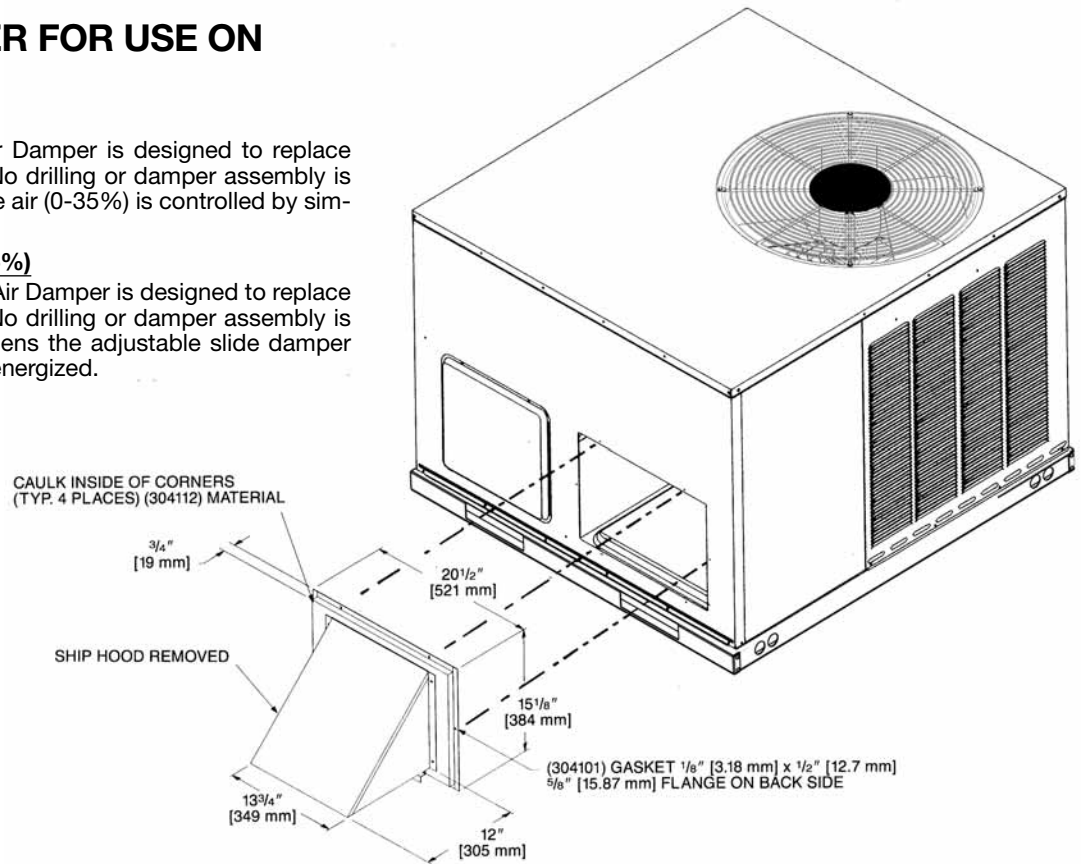

## ECONOMIZERS

### AXRE-CAA30 (3 Position) and AXRD-CAM10 (Fully Modulating)

#### AXRE-CAA30 (3 Position)

Provided with enthalpy control, and mixed air sensor. Settings include fully open, fully closed and adjustable mid point.

#### AXRD-CAM10 (Fully Modulating)

Provided with enthalpy control, mixed air sensor and minimum position potentiometer for proportioning (modulating) the amount of fresh air.

**Note:** See economizer installation instructions for correct filter access door.

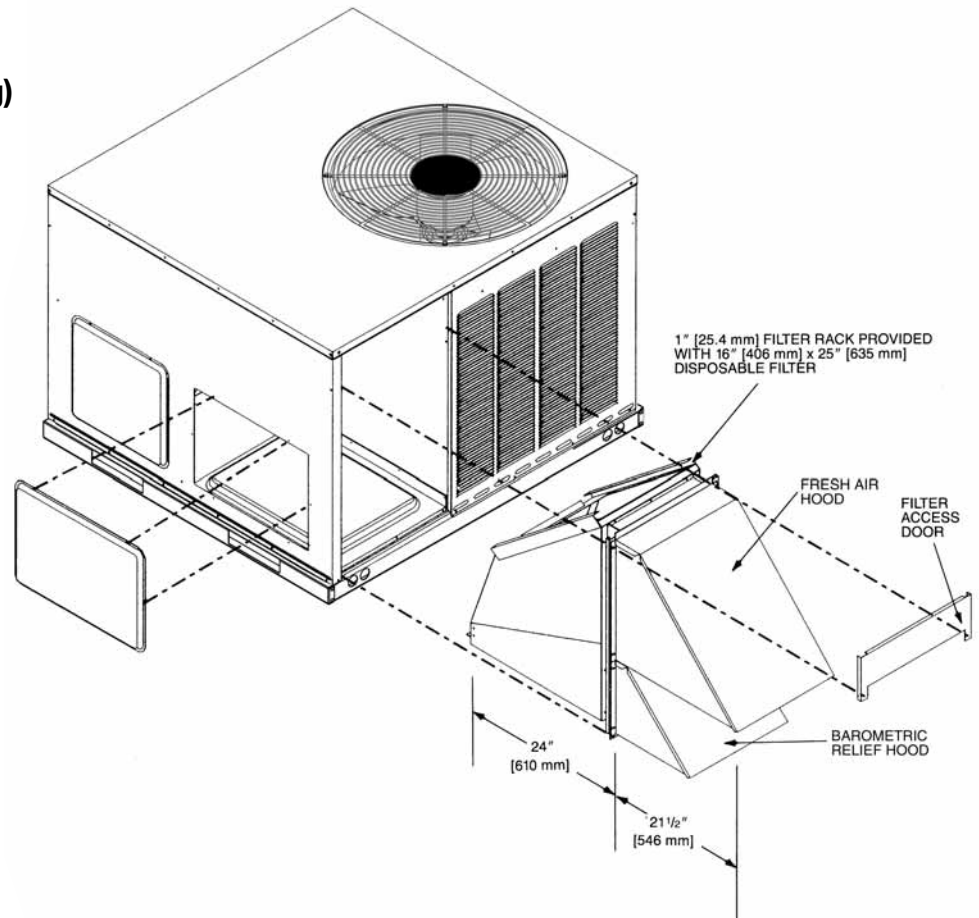

[ ] Designates Metric Conversions

## ECONOMIZERS

### AXRE-CAA30 (3 Position) and AXRD-CCM10 (Fully Modulating) for Horizontal Application

#### AXRE-CAA30 (3 Position)

Has outdoor air sensor, minimum position potentiometer, and mixed air sensor to provide three damper positions.

#### AXRD-CCM10 (Fully Modulating)

Provided with enthalpy control, mixed air sensor and minimum position potentiometer for proportioning (modulating) the amount of fresh air.

[ ] Designates Metric Conversions

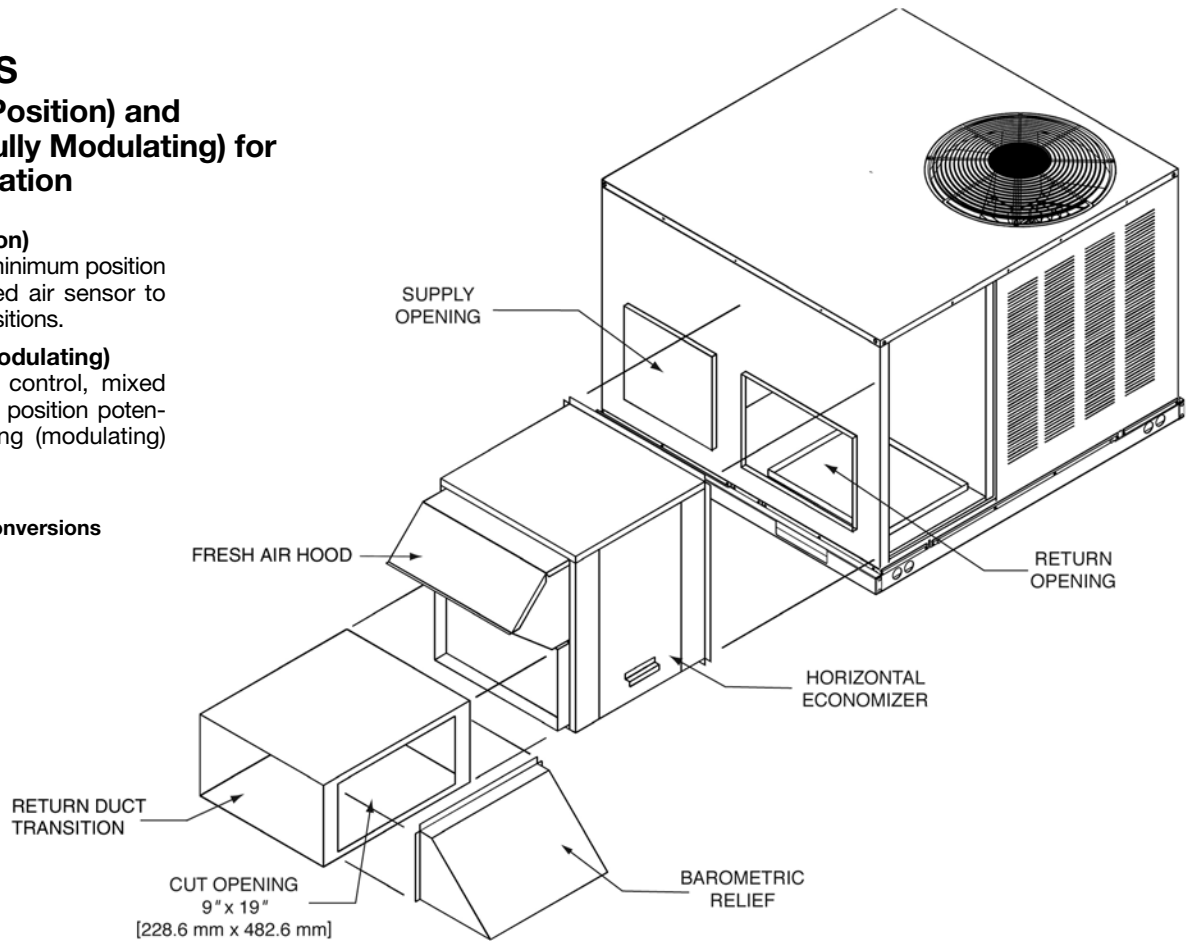

## THERMOSTATS



**200-Series \***  
Programmable



**300-Series \***  
Deluxe  
Programmable

**400-Series \***  
Special Applications/  
Programmable

Brand	Descriptor (3 Characters)	Series (3 Characters)	System (2 Characters)	Type (2 Characters)
RHC	- TST	213	UN	MS
RHC=Rheem	TST=Thermostat	200=Programmable 300=Deluxe Programmable 400=Special Applications/ Programmable	GE=Gas/Electric UN=Universal (AC/HP/GE) MD=Modulating Furnace DF=Dual Fuel	SS=Single-Stage MS=Multi-Stage

\* Photos are representative. Actual models may vary.

For detailed thermostat match-up information, see specification sheet form number T11-001.



## DUCT ADAPTER SIDEFLOW SQUARE TO ROUND TRANSITION AXMC-BA01

Adapts the side rectangular supply and return openings to 14" [356 mm] diameter round openings. Adapters provided with same finish as unit and also provided with thermal insulation.

[ ] Designates Metric Conversions

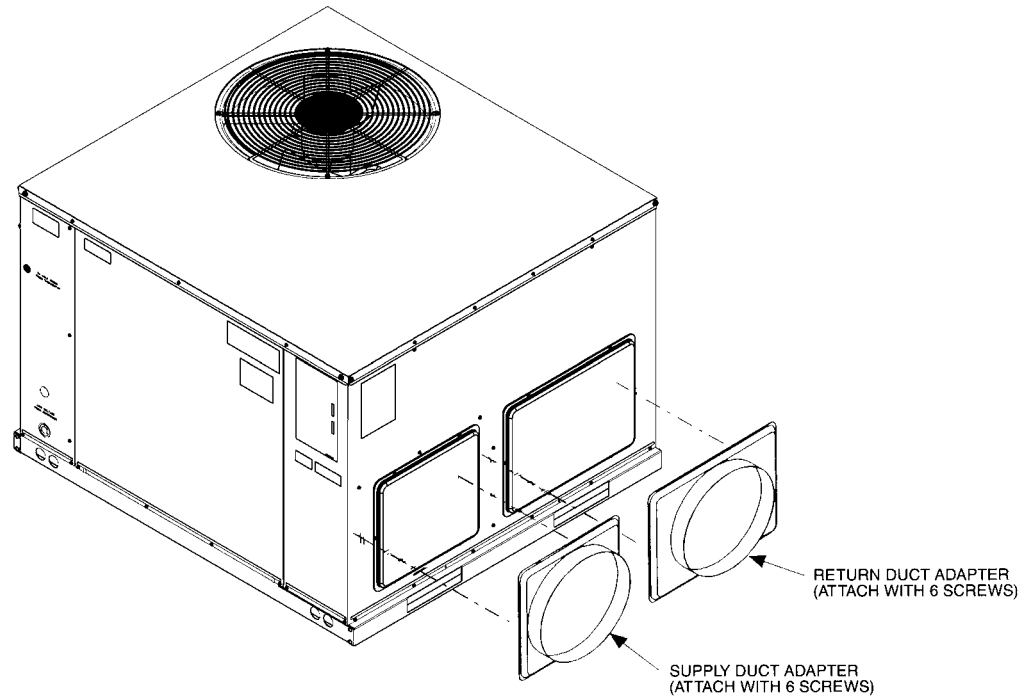

# ROOFCURB (Full Perimeter)

## RXSG-AAA08, RXSG-AAA14 and RXSG-AAA24 for RACA- Series

Hinged corners make for fast, easy set-up.

**RXSG-AAA08**  
**(8" [203 mm] High)**

NOT for use with  
RQKA/RQLA/RQMA  
Package Heat Pumps.

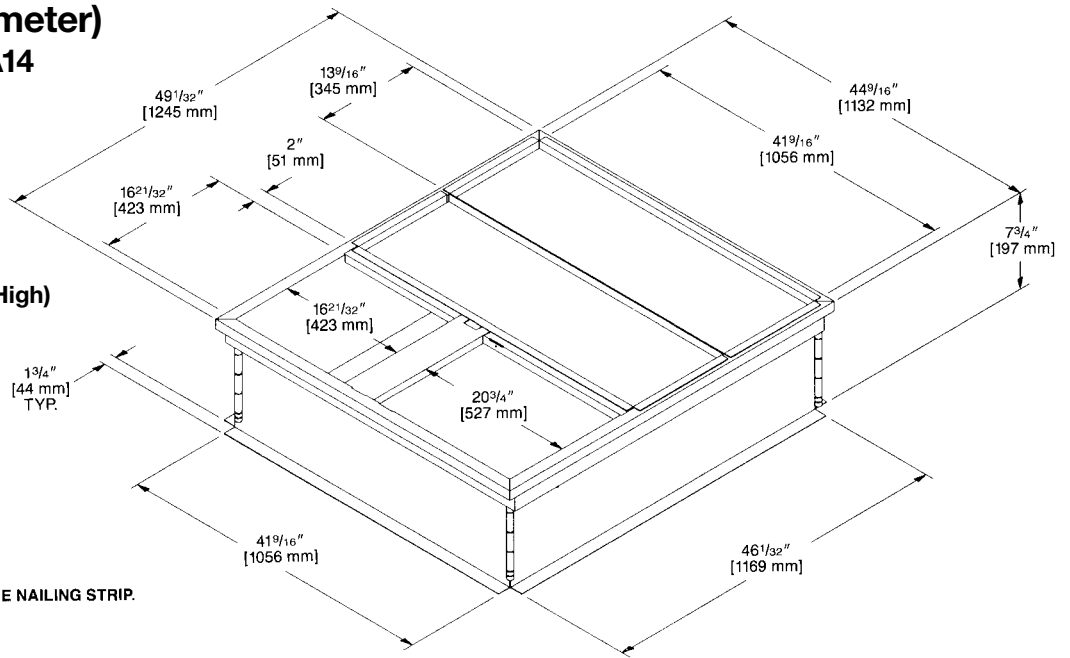

NOTE: PERIMETER OF ROOFCURB IS SUPPLIED WITH A NOMINAL 1" [25.4 mm] x 4" [102 mm] PINE NAILING STRIP.

**RXSG-AAA14**  
**(14" [356 mm] High)**

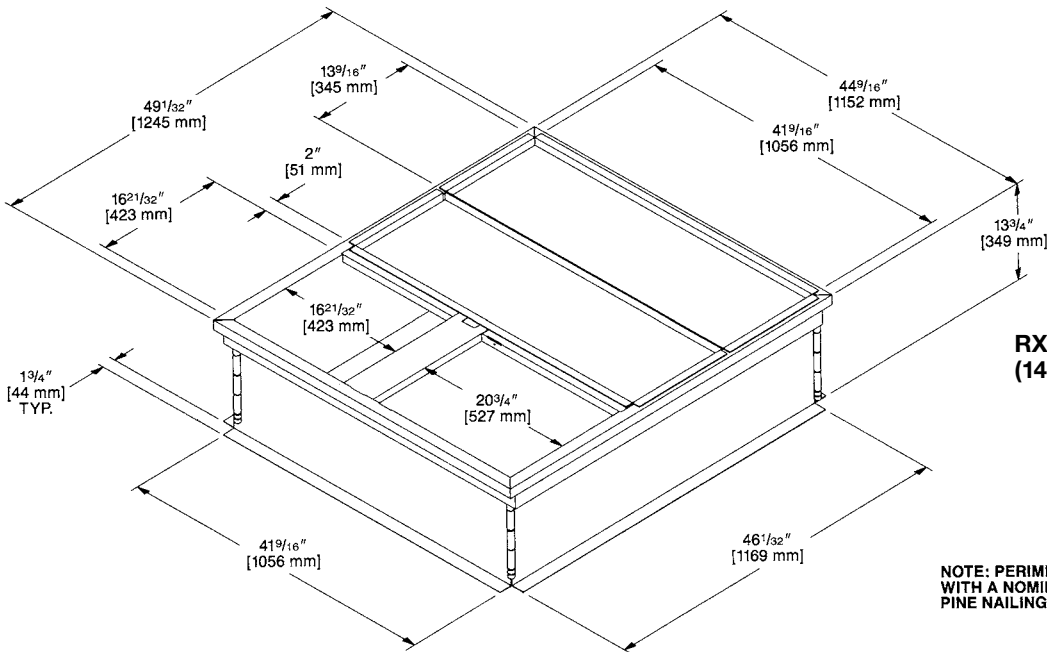

NOTE: PERIMETER OF ROOFCURB IS SUPPLIED WITH A NOMINAL 1" [25.4 mm] x 4" [102 mm] PINE NAILING STRIP.

[ ] Designates Metric Conversions

## ROOFCURB (Full Perimeter) (Cont.)

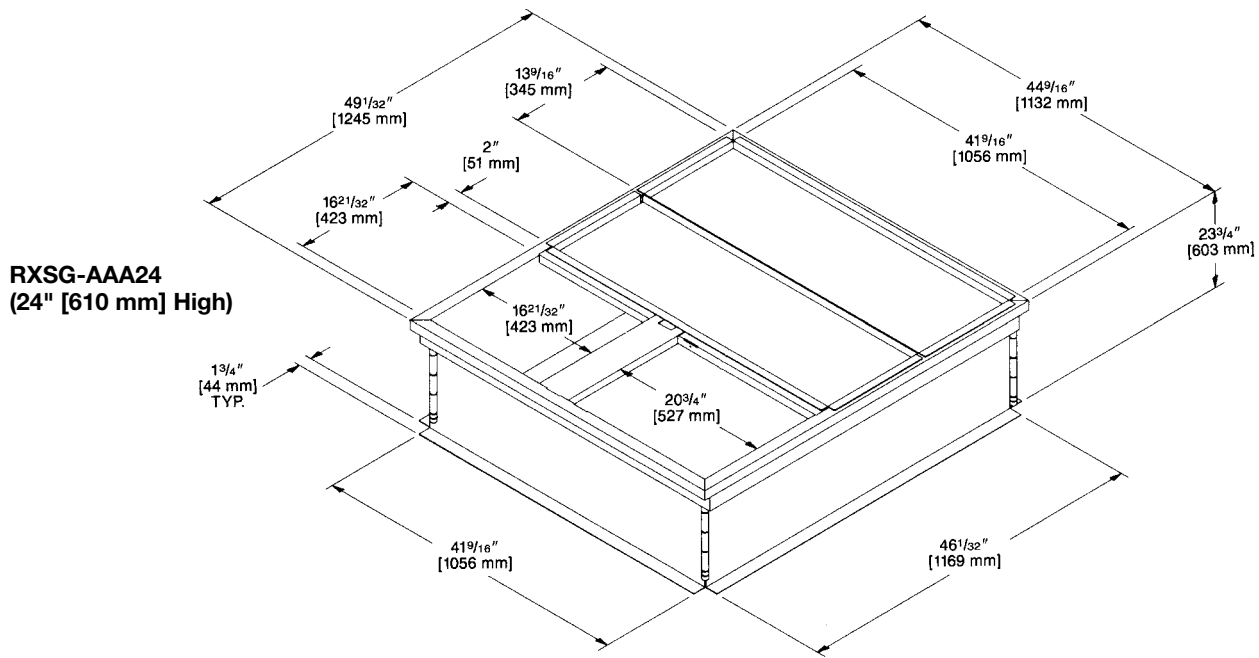

[ ] Designates Metric Conversions

# PACKAGE AIR CONDITIONERS & GAS/ELECTRIC PACKAGE UNITS ROOFCURB INSTALLATION (Full Perimeter)

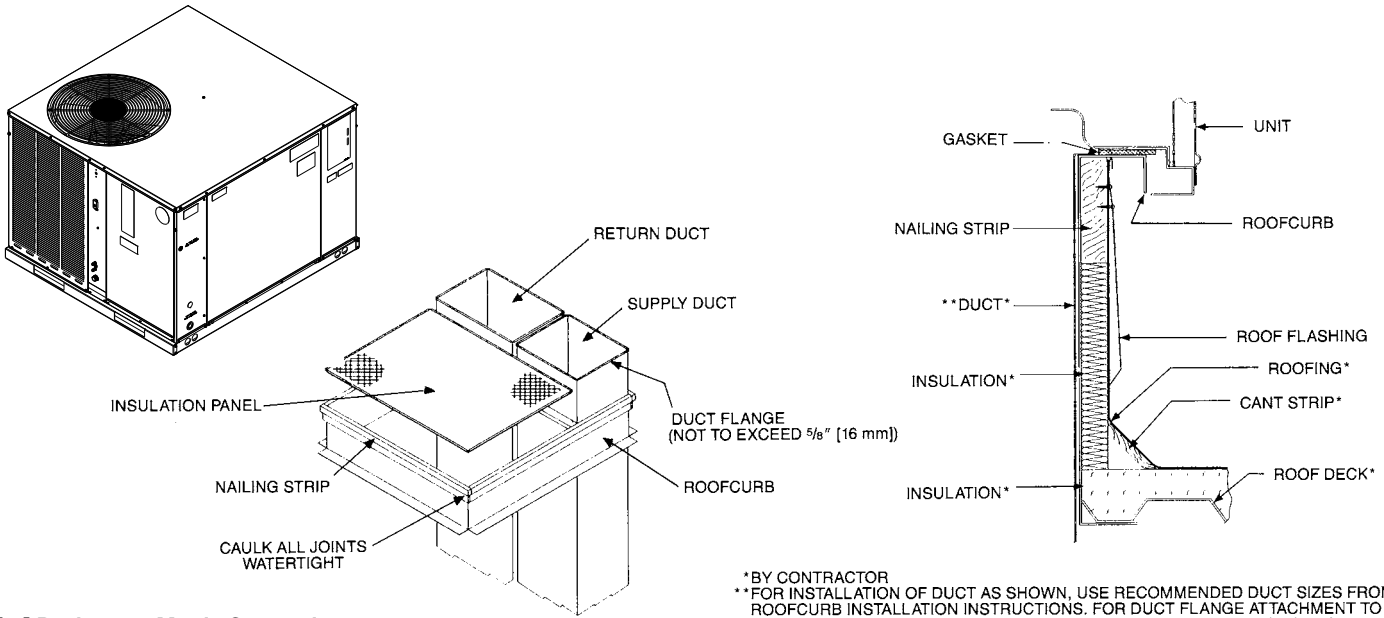

\*BY CONTRACTOR  
\*\*FOR INSTALLATION OF DUCT AS SHOWN, USE RECOMMENDED DUCT SIZES FROM ROOFCURB INSTALLATION INSTRUCTIONS. FOR DUCT FLANGE ATTACHMENT TO UNIT, SEE UNIT INSTALLATION INSTRUCTIONS FOR RECOMMENDED DUCT SIZES.

[ ] Designates Metric Conversions

## ROOFCURB ADAPTERS

Fabricated from galvanized steel to adapt the New cabinet to the old style curb. All are furnished with a New gasket.

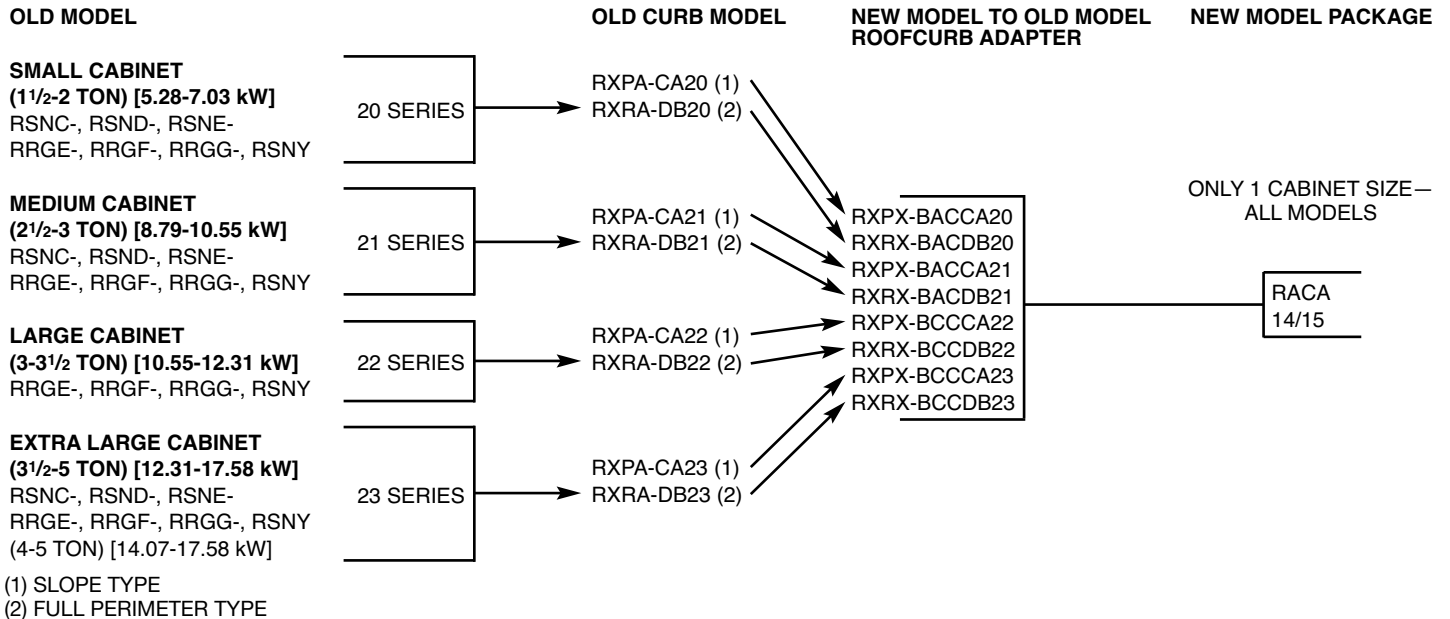

## ELECTRIC HEATER KITS – RACA13-

Unit Model Application	Electric Heater Kit Models
RACA (14/15) (024/030) AJ	RXQJ-A05J (208-240 volt, 1-ph, 5kW)
	RXQJ-A10J (208-240 volt, 1-ph, 10kW)
RACA (14/15) (036/042/048/060) AJ	RXQJ-A05J (208-240 volt, 1-ph, 5kW)
	RXQJ-A10J (208-240 volt, 1-ph, 10kW)
	RXQJ-A15J (208-240 volt, 1-ph, 15kW)
	RXQJ-A05J (208-240 volt, 1-ph, 5kW)
RACA (14/15) (036/042/048/060) AC	RXQJ-A10C (208-240 volt, 3-ph, 10kW)
	RXQJ-A15C (208-240 volt, 3-ph, 15kW)
	RXQJ-A10C (208-240 volt, 3-ph, 10kW)

### WARNING

**ONLY ELECTRIC HEATER KITS SUPPLIED BY THIS MANUFACTURER AS DESCRIBED IN THIS PUBLICATION HAVE BEEN DESIGNED, TESTED, AND EVALUATED BY A NATIONALLY RECOGNIZED SAFETY TESTING AGENCY FOR USE WITH THIS UNIT. USE OF ANY OTHER MANUFACTURED ELECTRIC HEATERS INSTALLED WITHIN THIS UNIT MAY CAUSE HAZARDOUS CONDITIONS RESULTING IN PROPERTY DAMAGE, FIRE, BODILY INJURY OR DEATH.**

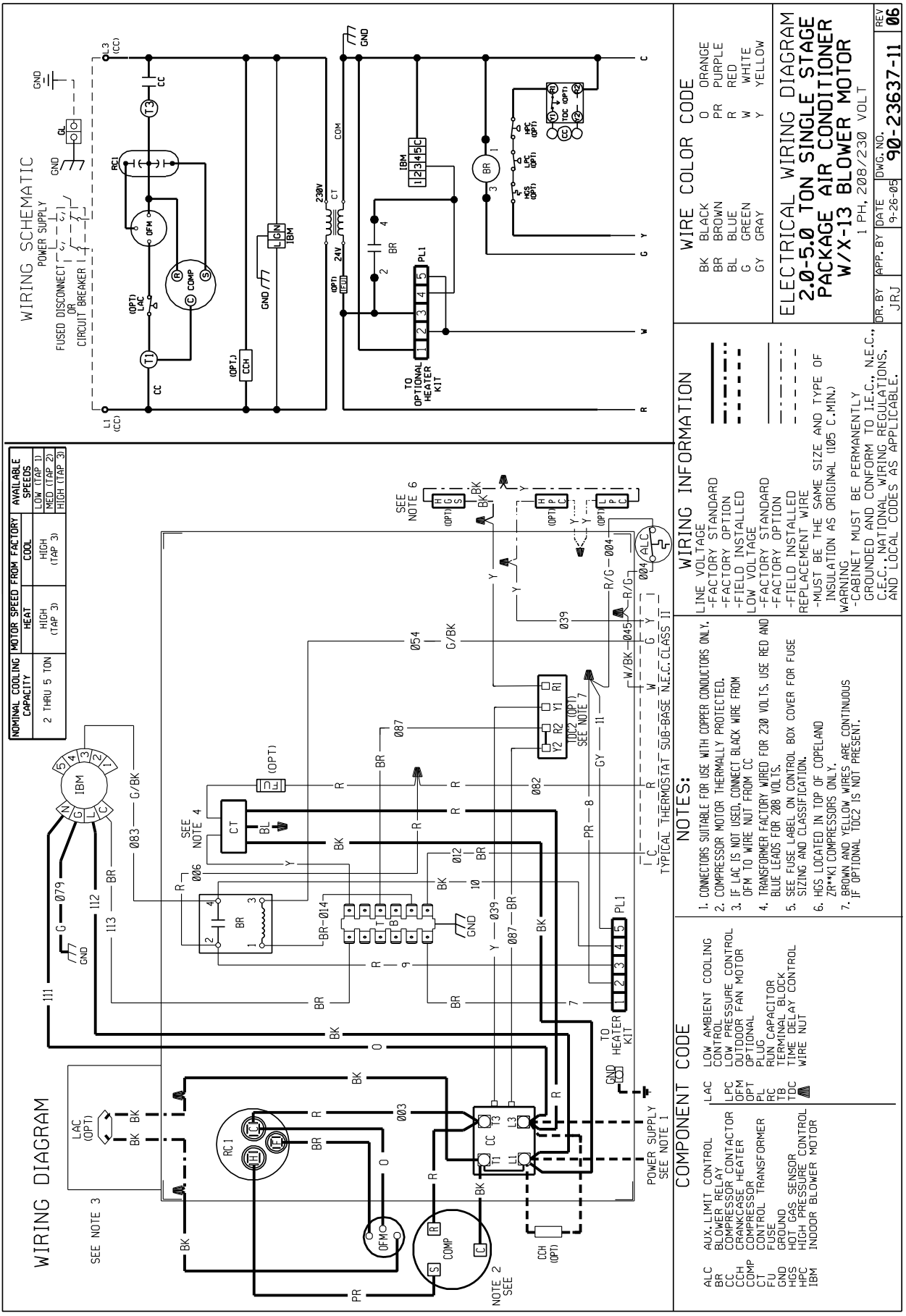

NOMINAL COOLING CAPACITY		MOTOR SPEED FROM FACTORY		AVAILABLE SPEEDS	
2 THRU 5 TON	HEAT HIGH (TAP 3)	COOL HIGH (TAP 3)	LOW (TAP 1)	MED (TAP 2)	HIGH (TAP 3)

#### ELECTRICAL WIRING DIAGRAM 2.0-5.0 TON SINGLE STAGE PACKAGE AIR CONDITIONER W/X-13 BLOWER MOTOR

WIRE COLOR CODE	
BK	BLACK
BR	BROWN
BL	BLUE
G	GREEN
GY	GRAY
O	ORANGE
PR	PURPLE
RED	RED
W	WHITE
Y	YELLOW

1 PH, 208/230 VOLT

#### WIRING INFORMATION

LINE VOLTAGE  
-FACTORY STANDARD  
-FACTORY OPTION  
-FIELD INSTALLED  
LOW VOLTAGE  
-FACTORY STANDARD  
-FACTORY OPTION  
-FIELD INSTALLED  
REPLACEMENT WIRE  
-MUST BE THE SAME SIZE AND TYPE OF INSULATION AS ORIGINAL (105 C-MIN.)

WARNING  
-CABINET MUST BE PERMANENTLY GROUNDED AND CONFORM TO I.E.C., N.E.C., C.E.C., NATIONAL WIRING REGULATIONS, AND LOCAL CODES AS APPLICABLE.

- #### NOTES:
1. CONNECTORS SUITABLE FOR USE WITH COPPER CONDUCTORS ONLY.
  2. COMPRESSOR MOTOR THERMALLY PROTECTED.
  3. IF LAC IS NOT USED, CONNECT BLACK WIRE FROM OPTM TO WIRE NUT FROM CC
  4. TRANSFORMER FACTORY WIRED FOR 230 VOLTS. USE RED AND BLUE LEADS FOR 208 VOLTS.
  5. SEE FUSE LABEL ON CONTROL BOX COVER FOR FUSE SIZING AND CLASSIFICATION.
  6. HGS LOCATED IN TOP OF COPELAND
  7. BROWN AND YELLOW WIRES ARE CONTINUOUS IF OPTIONAL 10C2 IS NOT PRESENT.

#### COMPONENT CODE

ALC	AUX. LIMIT CONTROL
BLW	BLOWER RELAY CONTROL
CC	CONTACTOR
CCH	COPPER HEATER
COMP	COMPRESSOR
CT	CONTROL TRANSFORMER
FU	FUSE
GND	GROUND
HGS	HOT GAS SENSOR
HPC	HIGH PRESSURE CONTROL
IBM	INDOOR BLOWER MOTOR
LAC	LOW AMBIENT COOLING CONTROL
LPC	LOW PRESSURE CONTROL
LEM	LEAK DETECTOR
OPT	OPTIONAL
PL	PLUG
RC	RUN CAPACITOR
TB	TERMINAL BLOCK
TDC	TIME DELAY CONTROL
W	WIRE NUT

REV	DWG. NO.
06	90-23637-11
APP. BY	DATE
JRJ	9-26-03

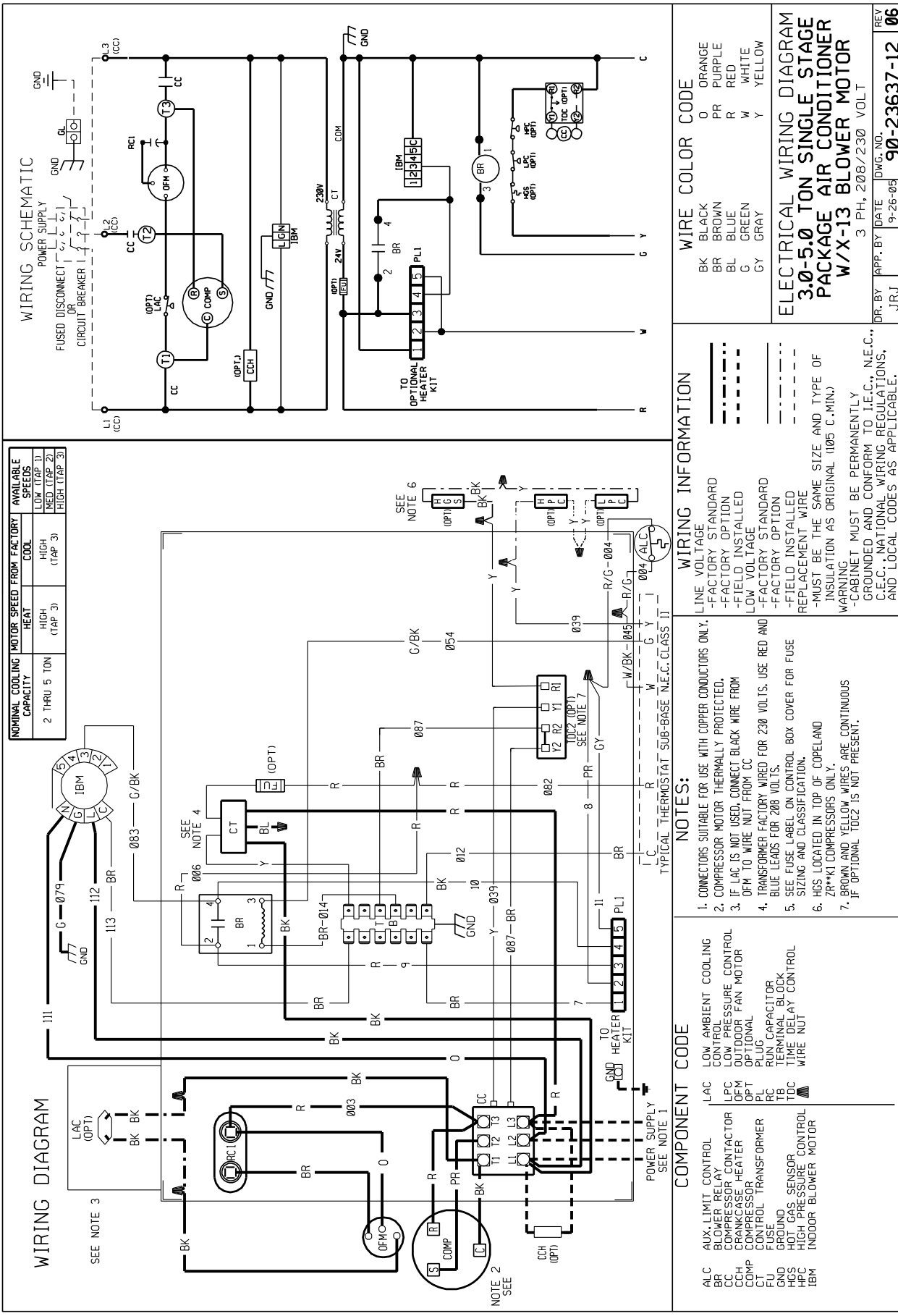

**WIRING SCHEMATIC**

POWER SUPPLY  
FUSED DISCONNECT  
CIRCUIT BREAKER

NOMINAL COOLING CAPACITY	MOTOR SPEED	FACTORY SPEEDS	AVAILABLE SPEEDS
2 THRU 5 TON	HEAT	HIGH (TAP 3)	HIGH (TAP 2)
	COOL	HIGH (TAP 3)	LOW (TAP 1)
			HIGH (TAP 2)

**WIRING DIAGRAM**

NOTE 3  
NOTE 2  
NOTE 4  
NOTE 7

**WIRE COLOR CODE**

BK	BLACK	0	ORANGE
BR	BROWN	PR	PURPLE
BL	BLUE	R	RED
G	GREEN	W	WHITE
GY	GRAY	Y	YELLOW

**ELECTRICAL WIRING DIAGRAM  
3.0-5.0 TON SINGLE STAGE  
PACKAGE AIR CONDITIONER  
W/X-13 BLOWER MOTOR**

3 PH, 208/230 VOLT  
DR. BY: JRJ  
APP. BY: JRJ  
DATE: 9-26-05  
DWG. NO.: 90-23637-12  
REV: 06

**WIRING INFORMATION**

- LINE VOLTAGE
- FACTORY STANDARD
- FACTORY OPTION
- FIELD INSTALLED
- LOW VOLTAGE
- FACTORY STANDARD
- FACTORY OPTION
- FIELD INSTALLED
- REPLACEMENT WIRE
- MUST BE THE SAME SIZE AND TYPE OF INSULATION AS ORIGINAL (105 C. MIN.)
- WARNING
- CABINET MUST BE PERMANENTLY GROUNDED AND CONFORM TO I.E.C., N.E.C., AND LOCAL WIRING REGULATIONS, AND LOCAL CODES AS APPLICABLE.

**NOTES:**

- CONNECTORS SUITABLE FOR USE WITH COPPER CONDUCTORS ONLY.
- COMPRESSOR MOTOR THERMALLY PROTECTED.
- IF LAC IS NOT USED, CONNECT BLACK WIRE FROM OFM TO WIRE NUT FROM CC
- TRANSFORMER FACTORY WIRING FOR 230 VOLTS. USE RED AND BLUE LEADS FOR 208 VOLTS.
- SEE FUSE LABEL ON CONTROL BOX COVER FOR FUSE SIZING AND CLASSIFICATION.
- HGS LOCATED IN TOP OF COPELAND ZR\*\*KI COMPRESSORS ONLY.
- BROWN AND YELLOW WIRES ARE CONTINUOUS. IF OPTIONAL TOC2 IS NOT PRESENT.

**COMPONENT CODE**

- ALC AUX. LIMIT CONTROL
- BR BLOWER RELAY
- LAC LOW AMBIENT COOLING CONTROL
- LPC LOW PRESSURE CONTROL
- CC CRANKCASE HEATER
- OFM OUTDOOR FAN MOTOR
- COMP COMPRESSOR
- OPT OPTIONAL
- CT CONTROL TRANSFORMER
- PL PLUG
- FC RUN CAPACITOR
- GND GROUND
- SENS SENSOR
- HTB HIGH PRESSURE CONTROL
- INDOOR BLOWER MOTOR

NOMINAL COOLING CAPACITY	MOTOR SPEED FROM FACTORY	AVAILABLE SPEEDS
5 TON	HEAT	LOW (TAP 1)
	HIGH (TAP 2)	HIGH (TAP 2)
		LOW (TAP 3)
	HIGH (TAP 4)	HIGH (TAP 4)
LOW (TAP 4)		

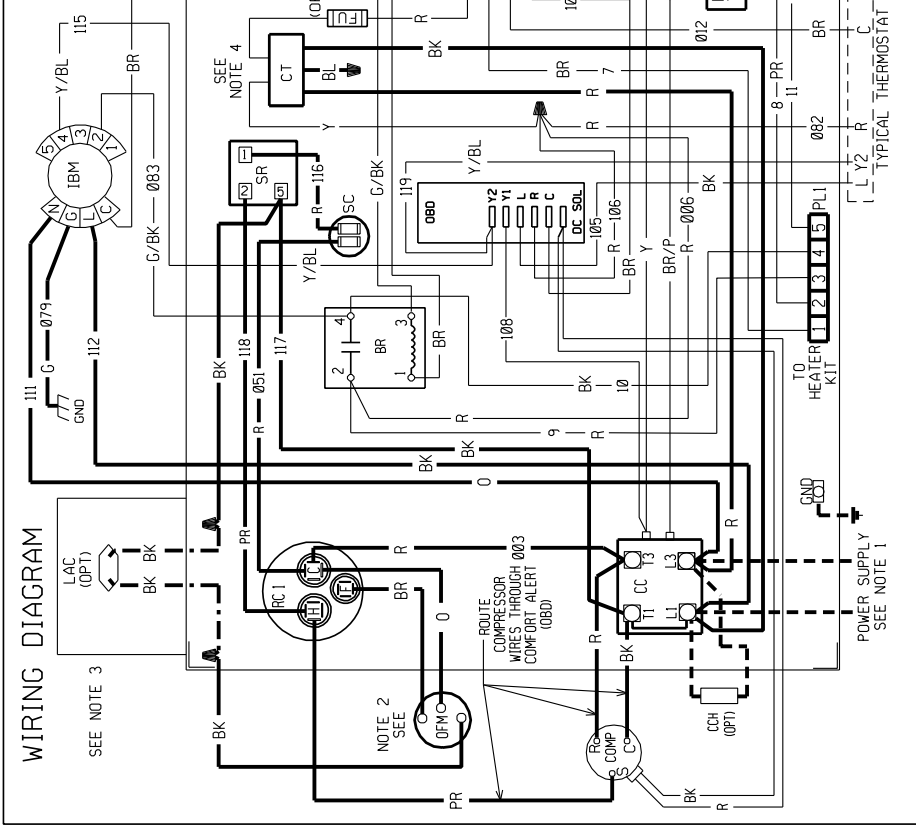

**WIRING DIAGRAM**

SEE NOTE 3

NOTE 2 SEE

SEE NOTE 4

SEE NOTE 6

SEE NOTE 1

TO HEATER KIT

TO HEATER KIT

TO HEATER KIT

TO HEATER KIT

TO HEATER KIT

TO HEATER KIT

TO HEATER KIT

TO HEATER KIT

TO HEATER KIT

TO HEATER KIT

TO HEATER KIT

TO HEATER KIT

TO HEATER KIT

TO HEATER KIT

TO HEATER KIT

**WIRING SCHEMATIC**

POWER SUPPLY  
FUSED DISCONNECT  
OR  
CIRCUIT BREAKER

TO HEATER KIT

TO HEATER KIT

TO HEATER KIT

**COMPONENT CODE**

ALC	AUX. LIMIT CONTROL
BR	BLOWER RELAY CONTACT
CC	CONDENSER CAPACITOR
CC	CRANK CASE HEATER
COMP	COMPRESSOR
CT	CONTROL TRANSFORMER
FU	FUSE
GND	GROUND
HGS	HOT GAS SENSOR
HPC	HIGH PRESSURE CONTROL
IBM	INDOOR BLOWER MOTOR
LAC	LOW AMBIENT COOLING CONTROL
LPC	LOW PRESSURE CONTROL
OB	ON-BOARD DIAGNOSTICS
OFM	OUTDOOR FAN MOTOR
OPT	OPTIONAL
PL	PLUG
RC	RUN CAPACITOR
SC	START CAPACITOR
SR	START RELAY
TB	TERMINAL BLOCK
TDC	TIME DELAY CONTROL
W	WIRE NUT

- NOTES:**
- CONNECTORS SUITABLE FOR USE WITH COPPER CONDUCTORS ONLY.
  - COMPRESSOR MOTOR THERMALLY PROTECTED.
  - IF LAC IS NOT USED, CONNECT BLACK WIRE FROM OFM TO WIRE NUT FROM CC
  - TRANSFORMER FACTORY WIRED FOR 230 VOLTS. USE RED AND BLUE LEADS FOR 288 VOLTS.
  - SEE FUSE LABEL ON CONTROL BOX COVER FOR FUSE SIZING AND CLASSIFICATION.
  - BROWN AND YELLOW WIRES ARE CONTINUOUS INSULATION AS ORIGINAL (105 C. MIN.)

- WIRING INFORMATION**
- LINE VOLTAGE
  - FACTORY STANDARD
  - FACTORY OPTION
  - FIELD INSTALLED
  - LOW VOLTAGE
  - FACTORY STANDARD
  - FACTORY OPTION
  - FIELD INSTALLED
  - REPLACE WIRE
  - MUST BE THE SAME SIZE AND TYPE OF INSULATION AS ORIGINAL (105 C. MIN.)
- WARNING:**
- CABINET MUST BE PERMANENTLY GROUNDED AND CONFORM TO I.E.C., N.E.C., C.E.C., NATIONAL WIRING REGULATIONS, AND LOCAL CODES AS APPLICABLE.

**ELECTRICAL WIRING DIAGRAM**

**5.0 TON**

**PACKAGE AIR CONDITIONER**

**W/X-13 BLOWER MOTOR**

1 PH, 208/230 VOLT

**WIRE COLOR CODE**

BK	BLACK	O	ORANGE
BR	BROWN	PR	PURPLE
BL	BLUE	R	RED
G	GREEN	W	WHITE
GY	GRAY	Y	YELLOW

DR. BY: JRJ    APP. BY: DATE    DWG. NO.    REV

11-9-95    90-23637-13    08



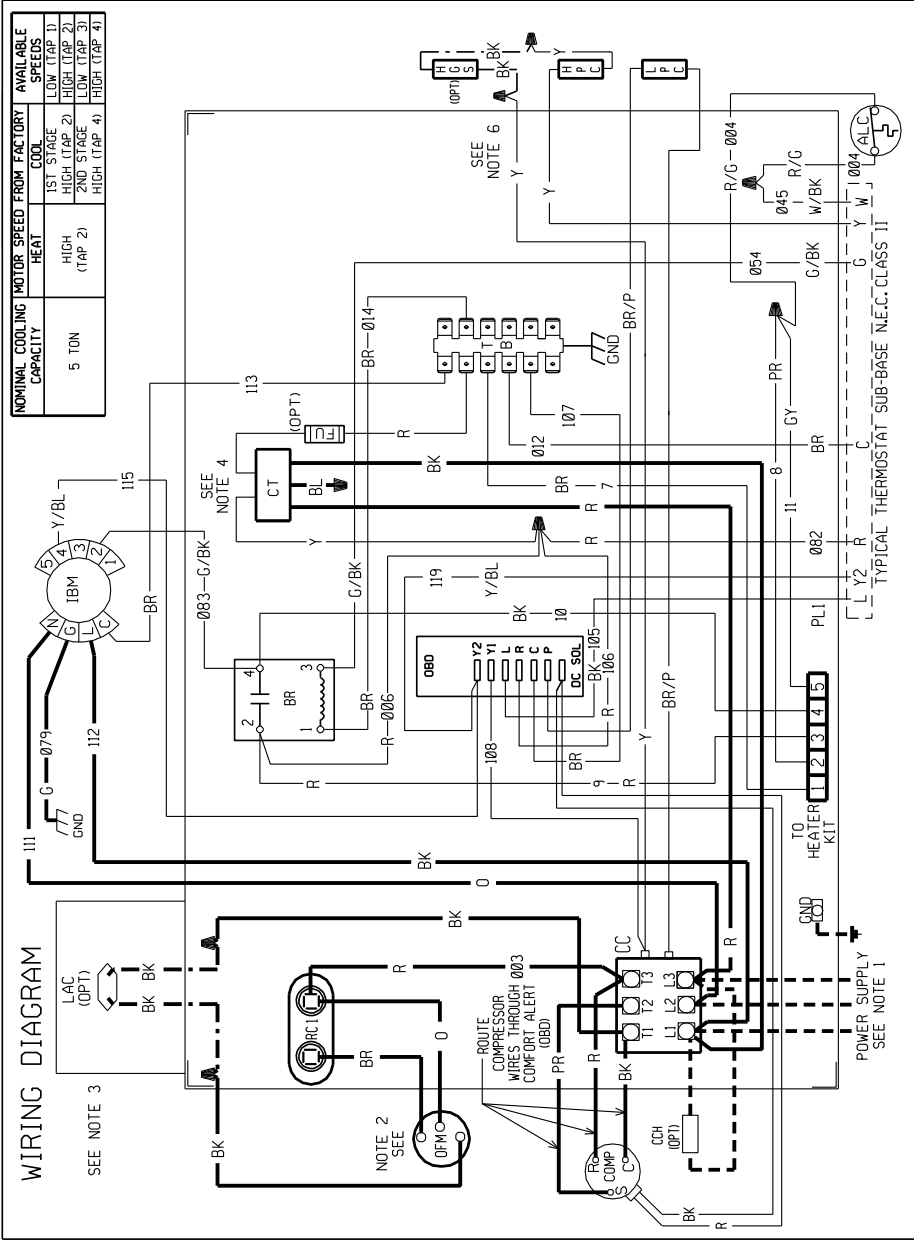
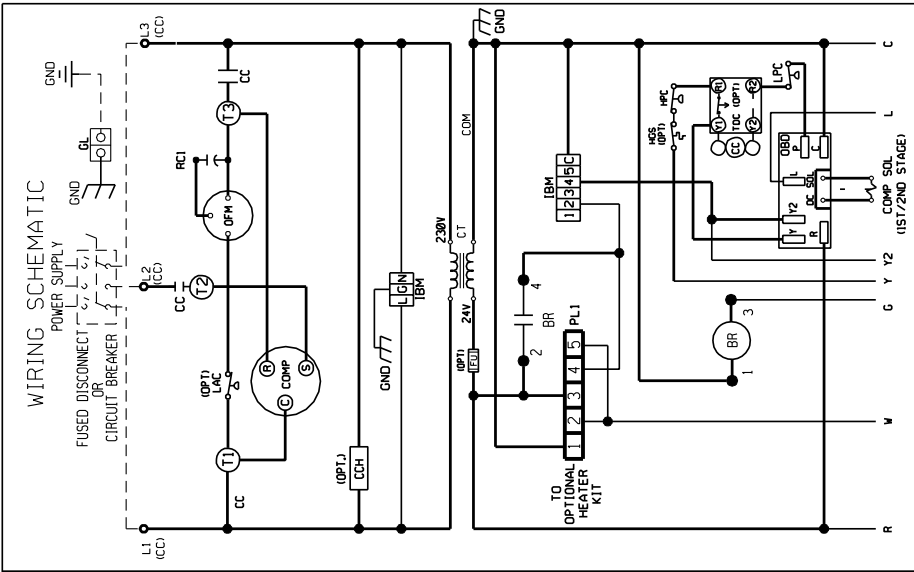

**WIRE COLOR CODE**

BK	BLACK	0	ORANGE
BR	BROWN	PR	PURPLE
BL	BLUE	R	RED
G	GREEN	W	WHITE
GY	GRAY	Y	YELLOW

**ELECTRICAL WIRING DIAGRAM**

**PACKAGE AIR CONDITIONER**

**W/X-13 BLOWER MOTOR**

3 PH, 208/230 VOLT

DR. BY JRJ DATE 11-10-05 DWG. NO. 90-23637-14 REV 08

**WIRING INFORMATION**

LINE VOLTAGE STANDARD  
-FACTORY OPTION  
-FIELD INSTALLED  
LOW VOLTAGE  
-FACTORY STANDARD  
-FIELD INSTALLED  
REPLACEMENT WIRE  
-MUST BE THE SAME SIZE AND TYPE OF INSULATION AS ORIGINAL (105 C. MIN.)  
-CABINET MUST BE PERMANENTLY GROUNDED AND CONFORM TO I.E.C., N.E.C., C.E.C., NATIONAL WIRING REGULATIONS, AND LOCAL CODES AS APPLICABLE.

- NOTES:**
- CONNECTORS SUITABLE FOR USE WITH COPPER CONDUCTORS ONLY.
  - COMPRESSOR MOTOR THERMALLY PROTECTED.
  - IF LAC IS NOT USED, CONNECT BLACK WIRE FROM OFM TO WIRE NUT FROM CC
  - TRANSFORMER FACTORY WIRED FOR 230 VOLTS. USE RED AND BLUE LEADS FOR 208 VOLTS.
  - SEE FUSE LABEL ON CONTROL BOX COVER FOR FUSE SIZING AND CLASSIFICATION.
  - BROWN AND YELLOW WIRES ARE CONTINUOUS. IF OPTIONAL LIMITS ARE NOT PRESENT.

**COMPONENT CODE**

ALC	AUX. LIMIT CONTROL
LAC	LOW AMBIENT COOLING CONTROL
BR	BLOWER RELAY
CC	COMPRESSOR CONTACTOR
CCH	CRANKCASE HEATER
COMP	COMPRESSOR
CT	CONTROL TRANSFORMER
FU	FUSE
GND	GROUND
HPS	HIGH PRESSURE CONTROL
IBM	INDOOR BLOWER MOTOR
LPC	LOW PRESSURE CONTROL
OBD	ON-BOARD DIAGNOSTICS
OFM	OUTDOOR FAN MOTOR
OPT	OPTIONAL
PL	PLUG
RC	REVERSE CAPACITOR
SC	START RELAY
TB	TERMINAL BLOCK
WIRE NUT	WIRE NUT

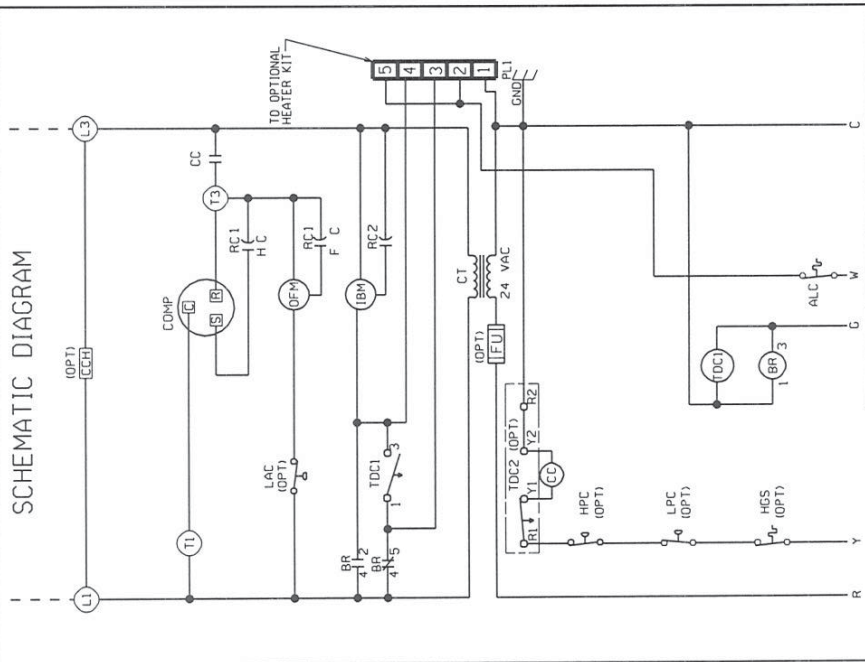

<b>WIRE COLOR CODE</b>	
BK.....BLACK	GR.....GREEN
BR.....BROWN	GY.....GRAY
BL.....BLUE	OR.....ORANGE
	W.....WHITE
	Y.....YELLOW
PR.....PURPLE	
R.....RED	

ELECTRICAL WIRING DIAGRAM	
2 - 3 TON	
PACKAGE AIR CONDITIONER	
W/PSC BLOWER MOTOR	
1 PH. 208/230 VOLT	

APPROVED:	CHECKER:	ORIGINAL RELEASE NO.:
MODELS: ZJW	DATE: 04-25-14	R-1059S013
PART NO.:	90-23637-20	REV: 00

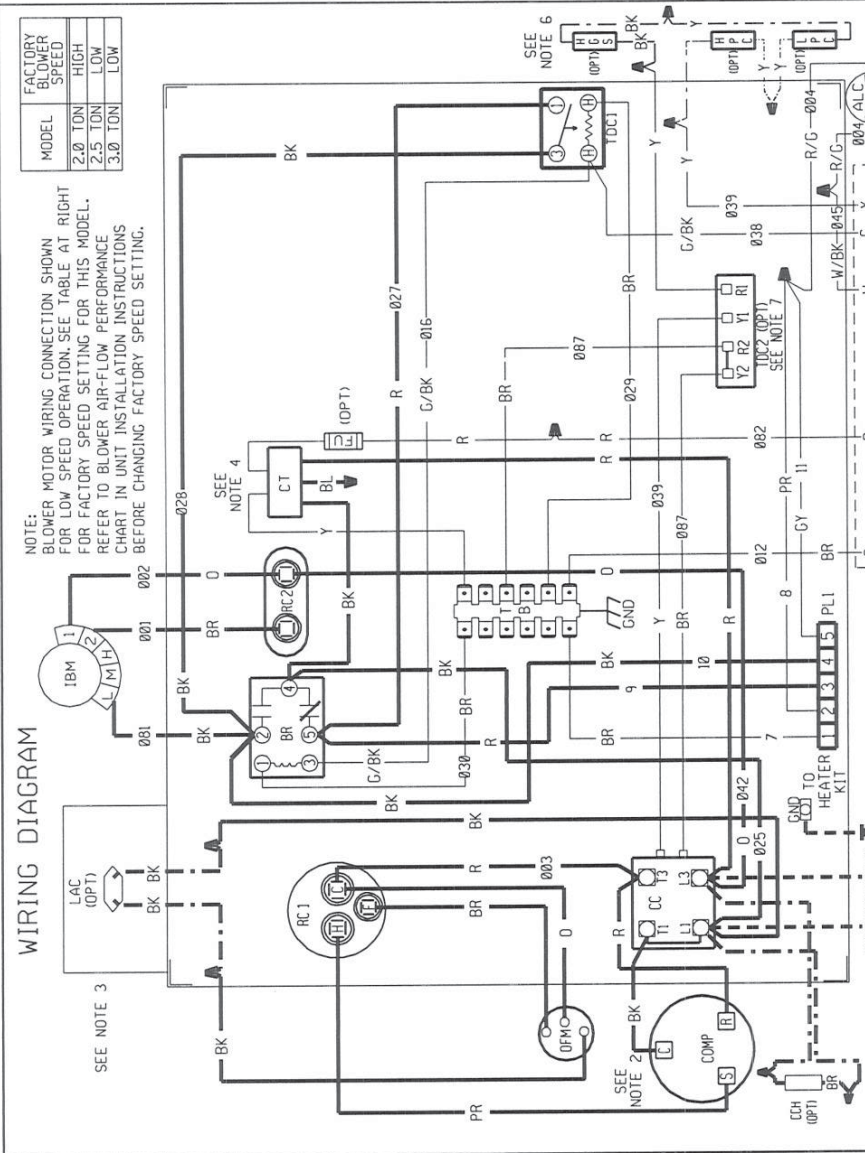

#### NOTES

- CONNECTORS SUITABLE FOR USE WITH COPPER CONDUCTORS ONLY
- COMPRESSOR MOTOR THERMALLY PROTECTED.
- IF LAC IS NOT USED, CONNECT BLACK WIRE FROM OPM TO WIRE NUT FROM CC
- TRANSFORMER FACTORY WIRED FOR 230 VOLTS. USE RED AND BLUE LEADS FOR 208 VOLTS.
- SEE FUSE LABEL ON CONTROL BOX COVER FOR FUSE SIZING AND CLASSIFICATION.
- HGS LOCATED IN TOP OF COPELAND ZRY-KIT COMPRESSORS ONLY.
- BROWN AND YELLOW WIRES ARE CONTINUOUS IF OPTIONAL TDCZ IS NOT PRESENT.

#### WIRING INFORMATION

LINE VOLTAGE \_\_\_\_\_  
 -FACTORY STANDARD \_\_\_\_\_  
 -FACTORY OPTION \_\_\_\_\_  
 -FIELD INSTALLED \_\_\_\_\_  
 -FIELD INSTALLED \_\_\_\_\_  
 -FACTORY STANDARD \_\_\_\_\_  
 -FIELD INSTALLED \_\_\_\_\_

REPLACEMENT WIRE MUST BE PERMANENTLY GROUNDED AND CONFORM TO I.E.C. - N.E.C. - C.E.C. OF INSULATION AS ORIGINAL. (105C. MIN.)

**WARNING**  
 -CABINET MUST BE PERMANENTLY GROUNDED AND CONFORM TO I.E.C. - N.E.C. - C.E.C. NATIONAL WIRING REGULATIONS, AND LOCAL CODES AS APPLICABLE

#### COMPONENT CODES

ALC	AUX. LIMIT CONTROL	LAC	LOW AMBIENT COOLING
BR	BLOWER RELAY	LPC	LOW PRESSURE CONTROL
CC	COMPRESSOR CONTACTOR	OPM	OUTDOOR FAN MOTOR
CCH	COMPRESSOR HEATER	OPT	OPTIONAL
COMP	COMPRESSOR	PL	PLUS
CT	CONTROL TRANSFORMER	RC	RUN CAPACITOR
FU	FUSE	RC	TERMINAL BLOCK
GR	GROUND	TB	TIME DELAY CONTROL
HGS	HOT GAS SENSOR	TDC	WIRE NUT
HPC	HIGH PRESSURE CONTROL		
IBM	INDOOR BLOWER MOTOR		

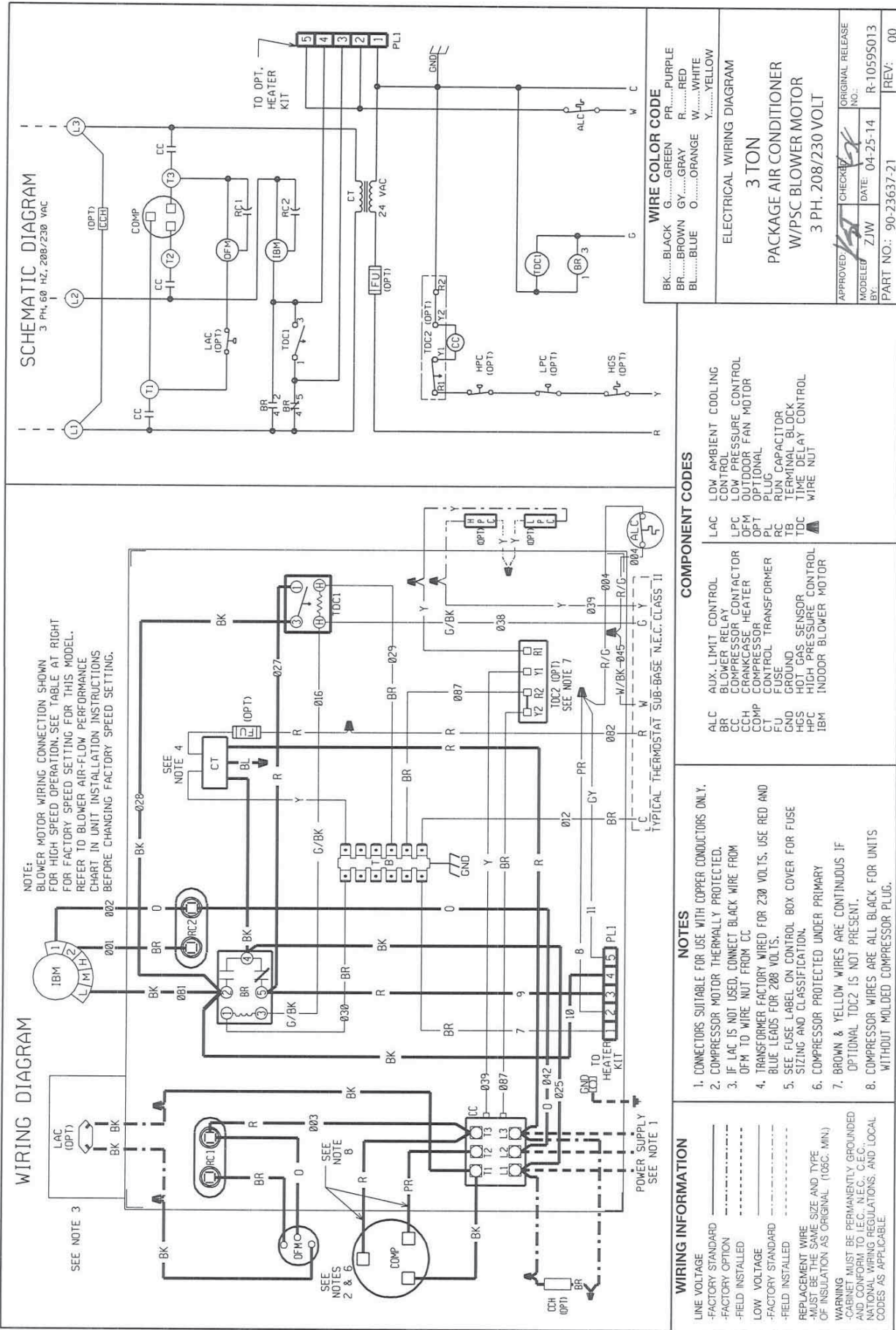

**SCHEMATIC DIAGRAM**  
3 PH, 60 HZ, 208/230 VAC

**WIRING DIAGRAM**

NOTE:  
BLOWER MOTOR WIRING CONNECTION SHOWN FOR HIGH SPEED OPERATION. SEE TABLE AT RIGHT FOR FACTORY SPEED SETTING FOR THIS MODEL. REFER TO BLOWER AIR-FLOW PERFORMANCE CHART IN UNIT INSTALLATION INSTRUCTIONS BEFORE CHANGING FACTORY SPEED SETTING.

**WIRE COLOR CODE**

BK.....BLACK	G.....GREEN	PR.....PURPLE
BR.....BROWN	GY.....GRAY	R.....RED
BL.....BLUE	O.....ORANGE	W.....WHITE
	Y.....YELLOW	

ELECTRICAL WIRING DIAGRAM  
**3 TON**  
PACKAGE AIR CONDITIONER  
W/PC BLOWER MOTOR  
3 PH, 208/230 VOLT

APPROVED:	CHECKED:	ORIGINAL RELEASE NO.:
MODELED: ZJW	DATE: 04-25-14	R-1059S013
PART NO.: 90-23637-21		REV: 00

**COMPONENT CODES**

- LAC LOW AMBIENT COOLING CONTROL
- LPC LOW PRESSURE CONTROL
- OFM OUTDOOR FAN MOTOR
- PLUG OPTIONAL PLUG
- RUN RUN CAPACITOR
- TERMINAL TERMINAL BLOCK
- TIME TIME DELAY CONTROL
- WIRE WIRE NUT

**NOTES**

1. CONNECTORS SUITABLE FOR USE WITH COPPER CONDUCTORS ONLY.
2. COMPRESSOR MOTOR THERMALLY PROTECTED.
3. IF LAC IS NOT USED, CONNECT BLACK WIRE FROM OFM TO WIRE NUT FROM CC
4. TRANSFORMER FACTORY WIRE FOR 230 VOLTS. USE RED AND BLUE LEADS FOR 208 VOLTS.
5. SEE FUSE LABEL ON CONTROL BOX COVER FOR FUSE SIZING AND CLASSIFICATION.
6. COMPRESSOR PROTECTED UNDER PRIMARY
7. BROWN & YELLOW WIRES ARE CONTINUOUS IF OPTIONAL TDC2 IS NOT PRESENT.
8. COMPRESSOR WIRES ARE ALL BLACK FOR UNITS WITHOUT MOLDED COMPRESSOR PLUG.

**WIRING INFORMATION**

- LINE VOLTAGE
- FACTORY STANDARD
- FACTORY OPTION
- FIELD INSTALLED
- LOW VOLTAGE
- FACTORY STANDARD
- FIELD INSTALLED
- REPLACEMENT WIRE
- MUST BE THE SAME SIZE AND TYPE
- OF INSULATION AS ORIGINAL (105C. MIN.)
- WARNING
- CABINET MUST BE PERMANENTLY GROUNDED AND CONFORM TO I.E.C., N.E.C., C.E.C., NATIONAL WIRING REGULATIONS, AND LOCAL CODES AS APPLICABLE.

**TYPICAL THERMOSTAT SUB-BASE N.E.C. CLASS II**

- ALC AUX. LIMIT CONTROL
- BR BLOWER RELAY
- CC COMPRESSOR CONTACTOR
- OFM CRANKCASE HEATER
- COMP COMPRESSOR
- CONTROL CONTROL TRANSFORMER
- FUSE FUSE
- CT CONDENSER FAN MOTOR
- GNND GROUND
- HCS HIGH CAPACITY SENSOR CONTROL
- IBM INDOOR BLOWER MOTOR

**BEFORE PURCHASING THIS APPLIANCE, READ IMPORTANT ENERGY COST AND EFFICIENCY INFORMATION AVAILABLE FROM YOUR RETAILER.**

### **GENERAL TERMS OF LIMITED WARRANTY\***

Rheem will furnish a replacement for any part of this product which fails in normal use and service within the applicable periods stated, in accordance with the terms of the limited warranty.

**\*For complete details of the Limited and Conditional Warranties, including applicable terms and conditions, contact your local contractor or the Manufacturer for a copy of the product warranty certificate.**

#### **Conditional Parts (Registration Required)**

1 Phase, Residential Applications.....Ten (10) Years

#### **Compressor**

1 Phase, Residential Applications.....Ten (10) Years

1 & 3 Phase, Commercial Applications.....Five (5) Years

#### **Parts**

1 & 3 Phase, Commercial Applications .....One (1) Year









The new degree of comfort.™

*In keeping with its policy of continuous progress and product improvement, Rheem reserves the right to make changes without notice.*

Rheem Heating, Cooling & Water Heating • P.O. Box 17010  
Fort Smith, Arkansas 72917 • [www.rheem.com](http://www.rheem.com)

Rheem Canada Ltd./Ltée • 125 Edgeware Road, Unit 1  
Brampton, Ontario • L6Y 0P5



INTEGRATED AIR & WATER

PRINTED IN U.S.A. 4/17 QG FORM NO. S11-969 REV. 2