



The new degree of comfort.™

SUBMITTAL COVER SHEET

PROJECT NAME _____

LOCATION _____

ARCHITECT _____

ENGINEER _____

CONTRACTOR _____

SUBMITTED BY _____ DATE _____

UNIT SUMMARY

| | | | | | | |
|---------------------|--|--|--|--|--|--|
| Quantity | | | | | | |
| Unit Designation | | | | | | |
| Model No. | | | | | | |
| Total Cooling | | | | | | |
| Sensible Cooling | | | | | | |
| Air Ent. Evaporator | | | | | | |
| Air Lvg. Evaporator | | | | | | |
| Heating Input | | | | | | |
| Heating Output | | | | | | |
| CFM/ESP | | | | | | |
| EER/SEER | | | | | | |
| Electrical | | | | | | |
| Minimum Ampacity | | | | | | |
| Min.-Max. Breaker | | | | | | |
| Net Unit Weight | | | | | | |
| Accessory | | | | | | |
| Catalog Form Number | | | | | | |

ACCESSORIES:

NOTES:



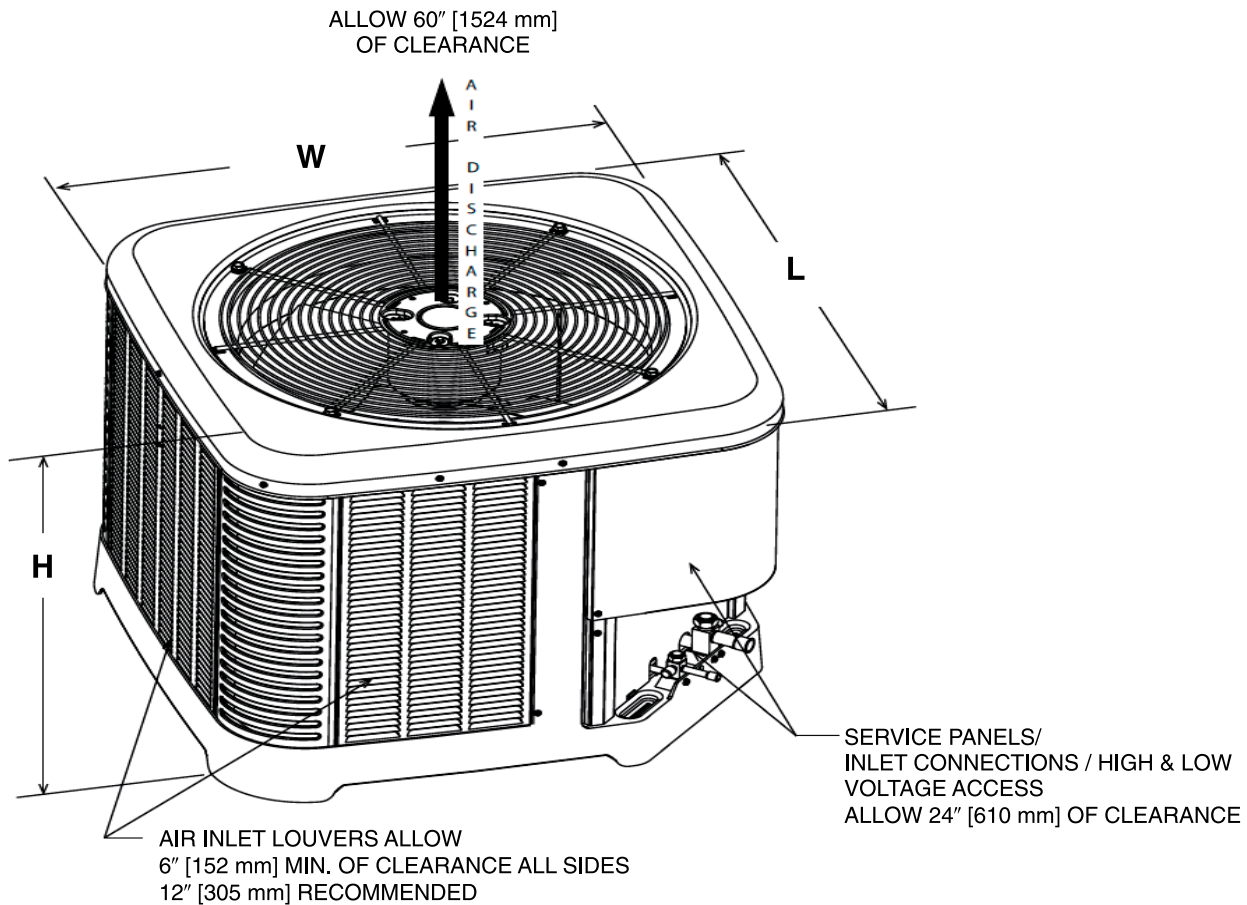

ST-A1226-02-00

Unit Dimensions

| MODEL NO. | OPERATING | | | | | | SHIPPING | | | | | |
|-----------|------------|------|------------|-----|-----------|-----|------------|------|------------|-----|-----------|-----|
| | H (Height) | | L (Length) | | W (Width) | | H (Height) | | L (Length) | | W (Width) | |
| | INCHES | mm | INCHES | mm | INCHES | mm | INCHES | mm | INCHES | mm | INCHES | mm |
| RA1724 | 31 | 787 | 33.75 | 857 | 33.75 | 857 | 36.75 | 933 | 36.38 | 924 | 36.38 | 924 |
| RA1736 | 35 | 889 | 33.75 | 857 | 33.75 | 857 | 40.75 | 1035 | 36.38 | 924 | 36.38 | 924 |
| RA1748 | 45 | 1143 | 35.75 | 908 | 35.75 | 908 | 52.75 | 1339 | 38.38 | 974 | 38.38 | 974 |
| RA1760 | 45 | 1143 | 35.75 | 908 | 35.75 | 908 | 52.75 | 1339 | 38.38 | 974 | 38.38 | 974 |

[] Designates Metric Conversions

Before proceeding with installation, refer to installation instructions packaged with each model, as well as complying with all Federal, State, Provincial, and Local codes, regulations, and practices.

Rheem Sales Company, Inc.
P.O. Box 17010, Fort Smith, AR 72917

"In keeping with its policy of continuous progress and product improvement, Rheem reserves the right to make changes without notice."