

PRINTING INSTRUCTIONS: MAKE EXACTLY 7.0 IN X 10.0 IN. WHITE BACKGROUND WITH BLACK PRINTING

MATERIAL: ADS-4574-01, PRESSURE SENSITIVE, ADHESIVE BACKED MATERIAL

REVISING

04	REVISED SCHEMATIC CONTACTORS WIRING .	VYM	G-0003S580 3/8/18
05	REVISED MOTOR SPEED WIRING TABLE AND NOTE UNDER IT.	VYM	Y-0699S069 06/10/19
03	ADDED 70/21" WIDE INFO. ON MOTOR SPEED WIRING TABLE. ADDED NOTE UNDER MOTOR SPEED WIRING TABLE	VYM	G-1019S191 7/16/18

NO REVISION TO DESIGN, MATERIAL, TOOLING, OR PROCESS IS ACCEPTABLE WITHOUT PRIOR APPROVAL FROM RHEEM THROUGH AN AUTHORIZED CHANGE NOTICE. A REVISED ENGINEERING SPECIFICATION AND A RESAMPLING OF PARTS. THE SUPPLIER IS RESPONSIBLE FOR NOTIFYING RHEEM R & D AND PURCHASING DEPARTMENTS IN WRITING OF ANY CHANGES AFFECTING PRODUCT QUALITY, PERFORMANCE, RELIABILITY, PACKAGING, DELIVERY OR WORKMANSHIP. ANY DOCUMENTS REFERRED TO ON THIS DRAWING ARE INCLUDED IN THE SPECIFICATIONS FOR THIS COMPONENT.

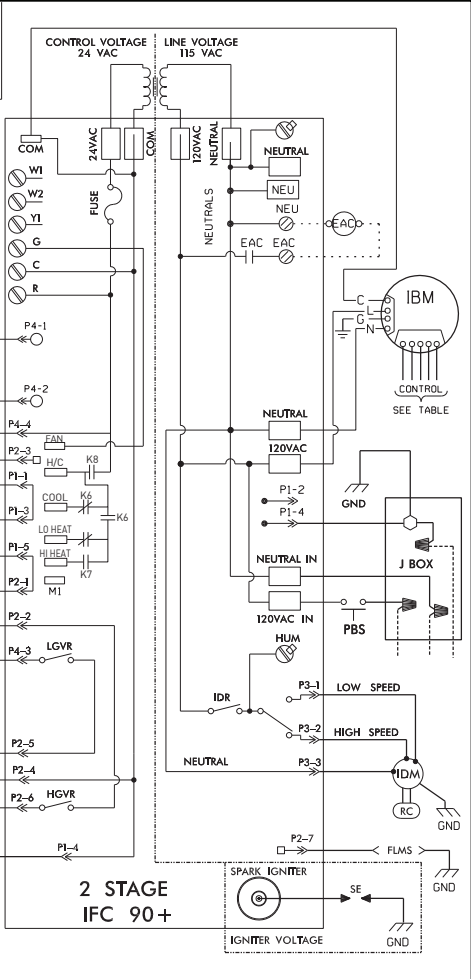
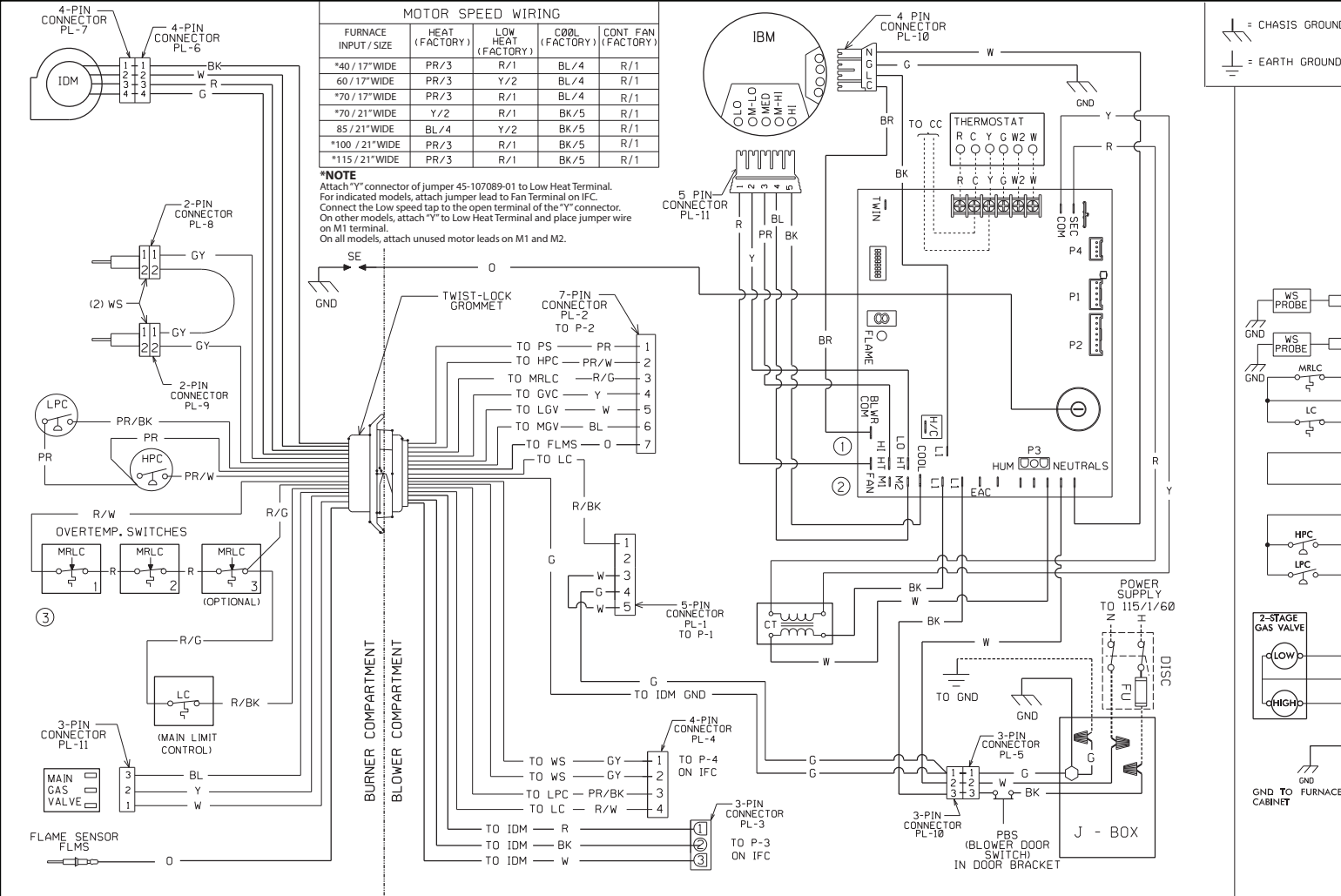

WIRING INFORMATION

LINE VOLTAGE
 -FACTORY STANDARD _____
 -FACTORY OPTION - - - - -
 -FIELD INSTALLED - - - - -

LOW VOLTAGE
 -FACTORY STANDARD _____
 -FACTORY OPTION - - - - -
 -FIELD INSTALLED - - - - -

REPLACEMENT WIRE
 -MUST BE THE SAME SIZE AND TYPE OF INSULATION AS ORIGINAL (105C. MIN.)

WARNING
 -CABINET MUST BE PERMANENTLY GROUND AND CONFORM TO I.E.C., N.E.C., C.E.C. NATIONAL WIRING REGULATIONS, AND LOCAL CODES AS APPLICABLE.

NOTES

① REFER TO SPEC SHEET FOR ACTUAL FACTORY MOTOR TAP PLACEMENT OF "HEAT" & "FAN" AS SOME MODELS MAY BE DIFFERENT THAN SHOWN HERE, ALSO REFER TO SPEC. SHEET OR INSTALLATION MANUAL IF WIRING OF HEAT AND/OR COOL SPEEDS IS NOT DESIREABLE.

② CONNECT UNUSED MOTOR LEADS TO M1 AND/OR M2

③ TWO OR THREE MRLC SWITCHES MAY BE PRESENT DEPENDING ON MODEL.

THE DOTTED BOX NEAR THE DRAWING NUMBER REPRESENTS A .25 X .25 DATA MATRIX. SEE ADS-104669-01 FOR DATA MATRIX SPECS.

COMPONENT CODES

BLWR BLOWER RELAY	IDR INDUCED DRAFT RELAY
C COMMON	IFC INTEGRATED FURNACE CONT
CC COOLING CONTACTOR	LC LIMIT CONTROL
CT CONTROL TRANSFORMER	LGV LOW GAS VALVE
DISC DISCONNECT SWITCH	LPC LOW PRESSURE CONTROL
EAC ELECT. AIR CLEANER OUTPUT	M MAIN
FLMS FLAME SENSOR	MC MEMORY CARD
FR FAN RELAY	MGV MAIN GAS VALVE
FU FUSE	MRLC MAN. RESET LIMIT CONTROL
GND GROUND	NEU NEUTRAL
GVC GAS VALVE COMMON	NPC NEGATIVE PRESSURE CONT.
GVR GAS VALVE RELAY	PBS PUSH BUTTON SWITCH
HALC HEAT ASSISTED LIMIT CONTROL	PFC POWER FACTOR CHOKE
HCR HEAT/COOL RELAY	PL PLUG
HGV HIGH GAS VALVE	PS PRESSURE SWITCH
HPC HIGH PRESSURE CONTROL	RC RUN CAPACITOR
HUM HUMIDIFIER OUTPUT	SE SPARK ELECTRODE
IBM INDOOR BLOWER MOTOR	TM THERMISTOR
IDM INDUCED DRAFT MOTOR	WS WATER SENSOR
	▲ WIRE NUT

ELECTRICAL WIRING DIAGRAM

UPFLOW / DOWNFLOW - HORIZONTAL
 BLOWER INDUCED DRAFT
 TWO STAGE 90PLUS
 CONSTANT TORQUE SELEC-TECH
 GAS FIRED, FORCED AIR FURNACE

APPROVED:	CHECKED:	ORIGINAL RELEASE NO.:
MODELED BY: JIM	DATE: 2-11-16	G-1025S001
PART NO.: 90-106223-01		REV: 05