



**DEPARTMENT OF REGULATORY AND ECONOMIC RESOURCES (RER)
BOARD AND CODE ADMINISTRATION DIVISION
NOTICE OF ACCEPTANCE (NOA)**

**MIAMI-DADE COUNTY
PRODUCT CONTROL SECTION**
11805 SW 26 Street, Room 208
Miami, Florida 33175-2474
T (786) 315-2590 F (786) 315-2599
www.miamidade.gov/economy

**Rheem Sales Company, Inc.
5600 Old Greenwood Rd.
Fort Smith, AR 72917**

SCOPE:

This NOA is being issued under the applicable rules and regulations governing the use of construction materials. The documentation submitted has been reviewed and accepted by Miami-Dade County RER-Product Control Section to be used in Miami-Dade County and other areas where allowed by the Authority Having Jurisdiction (AHJ).

This NOA shall not be valid after the expiration date stated below. The Miami-Dade County Product Control Section (In Miami-Dade County) and/ or the AHJ (in areas other than Miami-Dade County) reserve the right to have this product or material tested for quality assurance purposes. If this product or material fails to perform in the accepted manner, the manufacturer will incur the expense of such testing and the AHJ may immediately revoke, modify, or suspend the use of such product or material within their jurisdiction. RER reserves the right to revoke this acceptance if it is determined by Miami-Dade County Product Control Section that this product or material fails to meet the requirements of the applicable building code.

This product is approved as described herein and has been designed to comply with the Florida Building Code, including the High Velocity Hurricane Zone.

DESCRIPTION: Mechanical Unit Steel and Aluminum Tie-Down Clips for Grade and Rooftop Applications

APPROVAL DOCUMENT: Drawing No. **20-28800**, titled “Wind Load Certification of Mechanical Unit Cabinetry and Steel/ Aluminum Tie-Down Clips: At Grade and Roof Mounted Applications”, sheets 1 through 7 of 7, dated 05/14/2015, revised on 03/10/2023, prepared by Engineering Express, signed and sealed by Frank L. Bennardo, P.E., bearing the Miami-Dade County Product Control revision stamp with the Notice of Acceptance number and expiration date by the Miami-Dade County Product Control Section.

MISSILE IMPACT RATING: None

LABELING: Each unit shall bear a permanent label with the manufacturer's name or logo, city, state, model/ series, and following statement: "Miami-Dade County Product Control Approved", unless otherwise noted herein.

RENEWAL of this NOA shall be considered after a renewal application has been filed and there has been no change in the applicable building code negatively affecting the performance of this product.

TERMINATION of this NOA will occur after the expiration date or if there has been a revision or change in the materials, use, and/ or manufacture of the product or process. Misuse of this NOA as an endorsement of any product, for sales, advertising or any other purposes shall automatically terminate this NOA. Failure to comply with any section of this NOA shall be cause for termination and removal of NOA.

ADVERTISEMENT: The NOA number preceded by the words Miami-Dade County, Florida, and followed by the expiration date may be displayed in advertising literature. If any portion of the NOA is displayed, then it shall be done in its entirety.

INSPECTION: A copy of this entire NOA shall be provided to the user by the manufacturer or its distributors and shall be available for inspection at the job site at the request of the Building Official.

This NOA **revises NOA # 20-1102.09** and consists of this page 1 and evidence pages E-1, E-2, E-3 and E-4, as well as approval document mentioned above.

The submitted documentation was reviewed by **Carlos M. Utrera, P.E.**



**NOA No. 23-0328.04
Expiration Date: February 25, 2026
Approval Date: April 27, 2023
Page 1**

Rheem Sales Company, Inc.

NOTICE OF ACCEPTANCE: EVIDENCE SUBMITTED

1. Evidence submitted under previous NOAs

A. DRAWINGS “Submitted under NOA # 15-0903.08”

1. Drawing No. **15-2543GA** and **15-2564RE**, titled “Wind Load Certification of Mechanical Unit Cabinetry and Steel/Aluminum Tie-Down Clips: At Grade and Roof Mounted Applications”, sheets 1 through 7 of 7, dated 05/14/2015, revised on 11/20/2015, prepared by Engineering Express, signed and sealed by Frank L. Bennardo, P.E.

B. TESTS “Submitted under NOA # 15-0903.08”

1. Test report on Uniform Static Air Pressure Test per FBC, TAS 202-94 along with marked-up drawings and installation diagram of Rheem RA Series Mechanical Units, prepared by American Test Lab of South Florida, Test Report No. **0323.01-15**, dated 05/18/2015, signed and sealed by Stephen W. Warter, P.E.

C. CALCULATIONS “Submitted under NOA # 15-0903.08”

1. Anchorage calculations prepared by Engineering Express, dated 11/20/2015, signed and sealed by Frank L. Bennardo, P.E.

D. QUALITY ASSURANCE

1. Miami-Dade Department of Regulatory and Economic Resources (RER)

E. MATERIAL CERTIFICATIONS

1. None.

F. STATEMENT “Submitted under NOA # 15-0903.08”

1. Statement letter of code conformance to the 5th edition (2014) FBC issued by Engineering Express, dated 08/24/2015, signed and sealed by Frank L. Bennardo, P.E.
2. Statement letter of no financial interest issued by Engineering Express, dated 11/20/2015, signed and sealed by Frank L. Bennardo, P.E.
3. Distributor agreement dated 11/12/2015.



Carlos M. Utrera, P.E.
Product Control Examiner
NOA No. 23-0328.04
Expiration Date: February 25, 2026
Approval Date: April 27, 2023

NOTICE OF ACCEPTANCE: EVIDENCE SUBMITTED

2. Evidence submitted under NOA # 18-0321.11

A. DRAWINGS

1. Drawing No. **15-2543GA** and **15-2564RE**, titled “Wind Load Certification of Mechanical Unit Cabinetry and Steel/Aluminum Tie-Down Clips: At Grade and Roof Mounted Applications”, sheets 1 through 7 of 7, dated 05/14/2015, revised on 01/12/2018, prepared by Engineering Express, signed and sealed by Frank L. Bennardo, P.E.

B. TESTS

1. None.

C. CALCULATIONS

1. None.

D. QUALITY ASSURANCE

1. Miami-Dade Department of Regulatory and Economic Resources (RER)

E. MATERIAL CERTIFICATIONS

1. None.

F. STATEMENTS

1. Statement letter of code conformance to the 6th Edition (2017) FBC issued by Engineering Express, dated 03/19/2018, signed and sealed by Frank L. Bennardo, P.E.



Carlos M. Utrera, P.E.
Product Control Examiner
NOA No. 23-0328.04
Expiration Date: February 25, 2026
Approval Date: April 27, 2023

NOTICE OF ACCEPTANCE: EVIDENCE SUBMITTED

3. Evidence submitted under NOA # 18-0719.07

A. DRAWINGS

1. Drawing No. Drawing No. **15-2543GA** through **15-2543GD** and **15-2564RE**, titled “Wind Load Certification of Mechanical Unit Cabinetry and Steel/ Aluminum Tie-Down Clips: At Grade and Roof Mounted Applications”, sheets 1 through 7 of 7, dated 05/14/2015, revised on 01/12/2018, prepared by Engineering Express, signed and sealed by Frank L. Bennardo, P.E. on 07/17/2018.

B. TESTS

1. None.

C. CALCULATIONS

1. None.

D. QUALITY ASSURANCE

1. Miami-Dade Department of Regulatory and Economic Resources (RER)

E. MATERIAL CERTIFICATIONS

1. None.

F. STATEMENTS

2. Models removal request, dated 07/17/2018, signed and sealed by Frank L. Bennardo, P.E.



Carlos M. Utrera, P.E.
Product Control Examiner
NOA No. 23-0328.04
Expiration Date: February 25, 2026
Approval Date: April 27, 2023

NOTICE OF ACCEPTANCE: EVIDENCE SUBMITTED

4. Evidence submitted under NOA # 20-1102.09 and new

A. DRAWINGS

1. Drawing No. **20-28800**, titled “Wind Load Certification of Mechanical Unit Cabinetry and Steel/ Aluminum Tie-Down Clips: At Grade and Roof Mounted Applications”, sheets 1 through 7 of 7, dated 05/14/2015, revised on 03/10/2023, prepared by Engineering Express, signed and sealed by Frank L. Bennardo, P.E.

B. TESTS

1. None.

C. CALCULATIONS

1. None.

D. QUALITY ASSURANCE

1. Miami-Dade Department of Regulatory and Economic Resources (RER)

E. MATERIAL CERTIFICATIONS

1. None.

F. STATEMENTS

1. Statement letter of code conformance to the 7th edition (2020) FBC issued by Engineering Express, dated 10/19/2020, signed and sealed by Frank L. Bennardo, P.E.
2. Statement letter of no financial interest issued by Engineering Express, dated 10/19/2020, signed and sealed by Frank L. Bennardo, P.E.



Carlos M. Utrera, P.E.
Product Control Examiner
NOA No. 23-0328.04
Expiration Date: February 25, 2026
Approval Date: April 27, 2023

RHEEM SALES COMPANY, INC.

WIND LOAD CERTIFICATION OF MECHANICAL UNIT CABINETY AND STEEL/ALUMINUM TIE-DOWN CLIPS: AT GRADE MOUNTED APPLICATIONS

NON-SITE-SPECIFIC STRUCTURAL PERFORMANCE EVALUATION. A DESIGN PROFESSIONAL SHALL BE RESPONSIBLE FOR CERTIFYING THE APPLICATION OF THIS INFORMATION TO ANY SITE-SPECIFIC LOCATION.

FRANK BENNARDO, P.E.
PE# 0046549 CA# 9885

MARCH 16, 2023

APPROVED DESIGN CRITERIA:

ASCE 7 Vult=175 MPH
(Vasd-136 MPH), EXPOSURE 'D',
AT GRADE INSTALLATION ONLY

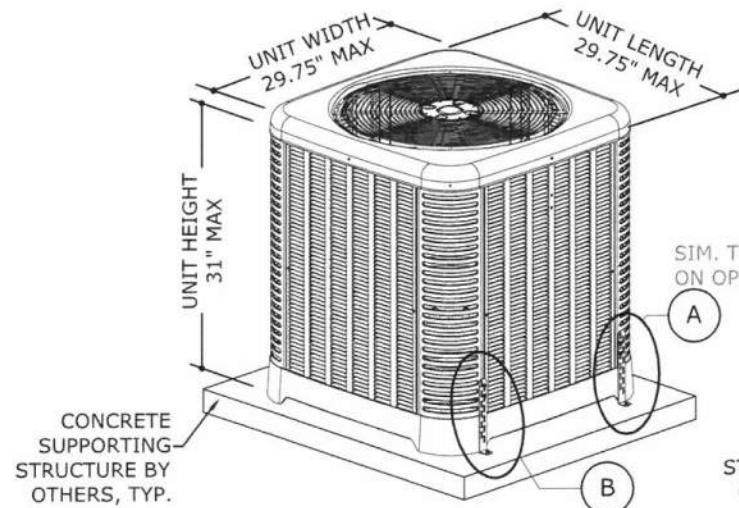

1 MECHANICAL UNIT
1 NOT TO SCALE FRONT ISOMETRIC

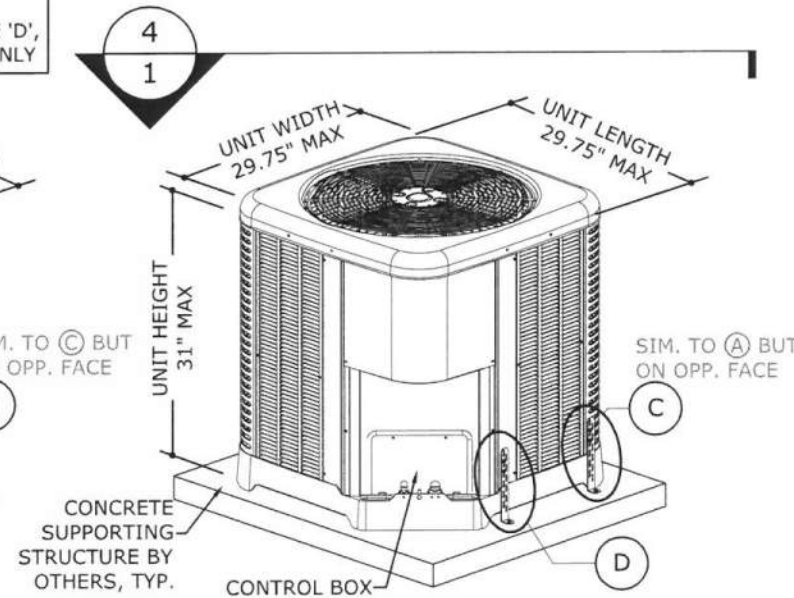

2 MECHANICAL UNIT
1 NOT TO SCALE BACK ISOMETRIC

THESE ISOMETRICS ARE INTENDED FOR DIAGRAMMATICAL PURPOSES ONLY; ALTERNATE RHEEM UNITS MAY VARY IN APPEARANCE

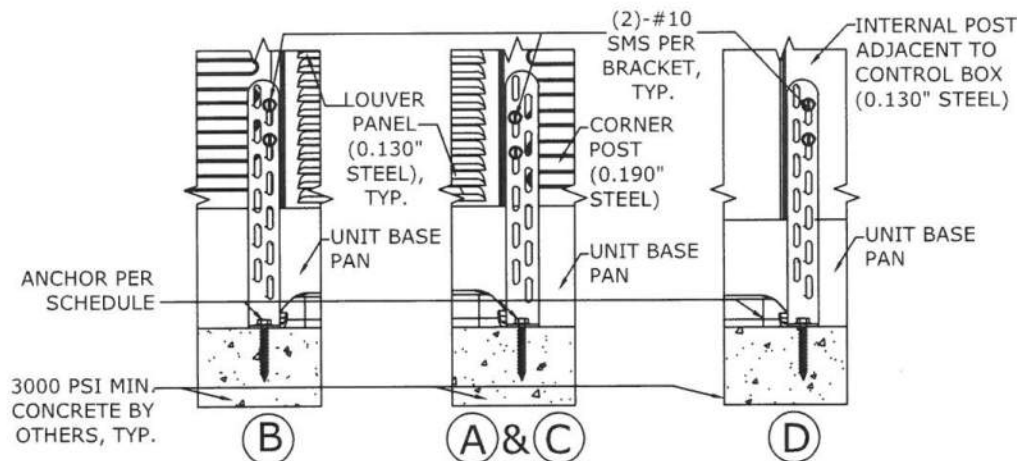

A & C ARE SIM AND OCCUR ON OPP. FACES

3 TIE-DOWN BRACKETS
1 NOT TO SCALE ELEVATION

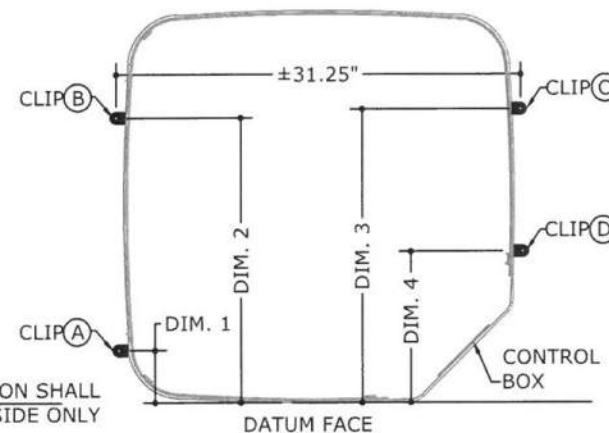

CLIP OFFSET DIMENSION SHALL BE TAKEN FROM THIS SIDE ONLY

4 TIE-DOWN BRACKET LAYOUT
1 NOT TO SCALE PLAN

ANCHOR SCHEDULE:

SUBSTRATE	DESCRIPTION
CONCRETE: (4" THICK MIN, 3000 PSI MIN.)	(1)-1/4"Ø STAINLESS STEEL ITW BUILDEX TAPCON, 1 3/4" FULL EMBED TO CONCRETE, 2 1/2" MIN. EDGE DISTANCE, 3" MIN. SPACING TO ANY ADJACENT ANCHOR.

TIE-DOWN BRACKET OFFSETS:

DIM. 1	4.50" MAX OFFSET FROM DATUM FACE
DIM. 2	24.50" MIN OFFSET FROM DATUM FACE
DIM. 3	25.25" MIN OFFSET FROM DATUM FACE
DIM. 4	13" MAX OFFSET FROM DATUM FACE

PRODUCT REVISED
as complying with the Florida
Building Code
NOA-No. 23-0328.04

Expiration Date 02/25/2026

By *[Signature]*
Miami-Dade Product Control

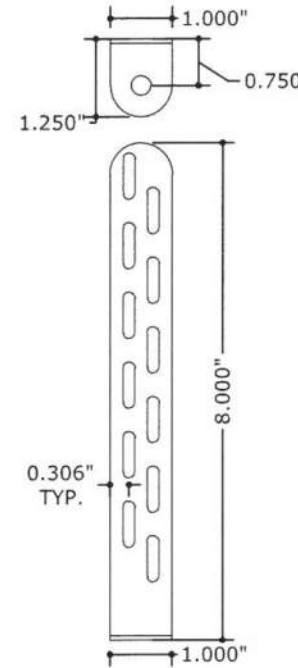

TIE-DOWN BRACKET

MIAMI TECH CLIP: 14GA (0.07")
ASTM A653 Fu=90 KSI STEEL (CUTD8) OR 0.080" 5052-H32 ALUMINUM (CUTDA8), MIAMI TECH KIT # RRCUTDSMK OR RRCUTDASMK

DESIGN NOTES:

THIS SYSTEM HAS BEEN DESIGNED IN ACCORDANCE WITH ASCE 7 AND THE FLORIDA BUILDING CODE SEVENTH EDITION (2020) FOR USE WITHIN AND OUTSIDE THE HIGH VELOCITY HURRICANE ZONE. THE DESIGN CRITERIA CONSIDERS ASCE 7 SECTION 29 FOR "OTHER STRUCTURES - SOLID FREESTANDING WALLS" INSTALLATIONS AT GRADE. ALL DESIGN VARIABLES ARE IN ACCORDANCE WITH ASCE 7 CHAPTERS 26 & 29.

GENERAL NOTES:

- THIS SYSTEM HAS BEEN DESIGNED AND SHALL BE FABRICATED IN ACCORDANCE WITH THE REQUIREMENTS OF THE FLORIDA BUILDING CODE SEVENTH EDITION (2020) & ASCE 7. THIS SYSTEM MAY BE USED WITHIN AND OUTSIDE THE HIGH VELOCITY HURRICANE ZONE. THIS DESIGN IS NOT INTENDED TO CERTIFY IMPACT RESISTANCE OF THE MECHANICAL UNIT CABINETY.
- NO 33-1/3% INCREASE IN ALLOWABLE STRESS HAS BEEN USED IN THE DESIGN OF THIS SYSTEM.
- DESIGN & CERTIFICATION OF THE UNIT CABINETY IS APPROVED THROUGH TEST REPORT#0323.01-15 BY AMERICAN TEST LAB OF SOUTH FLORIDA.
- ALL MODELS WITH THE MAXIMUM DIMENSIONS, MINIMUM WEIGHT (120 LB MINIMUM), AND MINIMUM MATERIAL STRENGTH, THICKNESS, AND FASTENERS SHOWN HEREIN ARE COVERED UNDER THIS NOA.** MODELS SHALL CONFORM TO THE LIMITATIONS STATED HEREIN. ALL MECHANICAL SPECIFICATIONS (CLEAR SPACE, TONNAGE, ETC.) SHALL BE AS PER MANUFACTURER RECOMMENDATIONS AND ARE THE EXPRESS RESPONSIBILITY OF THE CONTRACTOR.
- TAPCONS REFERRED TO HEREIN SHALL BE ITW BUILDEX BRAND, ASTM F593 410 STAINLESS STEEL OR EQUIVALENT ONLY, INSTALLED TO 3000 PSI MIN CONCRETE. SEE ANCHOR SCHEDULE FOR ANCHOR REQUIREMENTS. ALL SHEET METAL SCREWS USED TO FASTEN BRACKETS TO MECHANICAL UNITS SHALL BE #10 (14 MIN THREADS PER INCH) ASTM F593 410 STAINLESS STEEL OR EQUIVALENT ONLY. PROVIDE (5) PITCHES MINIMUM PAST THE THREAD PLANE FOR SHEET METAL SCREWS. ALL FASTENERS SHALL HAVE APPROPRIATE CORROSION PROTECTION TO PREVENT ELECTROLYSIS.
- ALL CONCRETE SPECIFIED HEREIN IS NOT PART OF THIS CERTIFICATION. AS A MINIMUM, ALL CONCRETE SHALL BE STRUCTURAL CONCRETE 4" MIN. THICK AND SHALL HAVE MINIMUM COMPRESSIVE STRENGTH OF 3000 PSI, UNLESS NOTED OTHERWISE.
- THE CONTRACTOR IS RESPONSIBLE TO INSULATE ALL MEMBERS FROM DISSIMILAR MATERIALS TO PREVENT ELECTROLYSIS.
- ELECTRICAL GROUND, WHEN REQUIRED, TO BE DESIGNED & INSTALLED BY OTHERS.
- THE ADEQUACY OF ANY EXISTING STRUCTURE TO WITHSTAND SUPERIMPOSED LOADS SHALL BE VERIFIED BY THE ONSITE DESIGN PROFESSIONAL AND IS NOT INCLUDED IN THIS CERTIFICATION. EXCEPT AS EXPRESSLY PROVIDED HEREIN, NO ADDITIONAL CERTIFICATIONS OR AFFIRMATIONS ARE INTENDED.
- THE SYSTEM DETAILED HEREIN IS GENERIC AND DOES NOT PROVIDE INFORMATION FOR A SPECIFIC SITE. FOR SITE CONDITIONS DIFFERENT FROM THE CONDITIONS DETAILED HEREIN, A LICENSED ENGINEER OR REGISTERED ARCHITECT SHALL PREPARE SITE SPECIFIC DOCUMENTS FOR USE IN CONJUNCTION WITH THIS DOCUMENT.
- WATER-TIGHTNESS OF EXISTING HOST SUBSTRATE SHALL BE THE FULL RESPONSIBILITY OF THE INSTALLING CONTRACTOR. CONTRACTOR SHALL ENSURE THAT ANY REMOVED OR ALTERED WATERPROOFING MEMBRANE IS RESTORED AFTER FABRICATION AND INSTALLATION OF STRUCTURE PROPOSED HEREIN. THIS ENGINEER SHALL NOT BE RESPONSIBLE FOR ANY WATERPROOFING OR LEAKAGE ISSUES WHICH MAY OCCUR AS WATER-TIGHTNESS SHALL BE THE FULL RESPONSIBILITY OF THE INSTALLING CONTRACTOR.
- FOR AN EXPLANATION OF EXPOSURE CATEGORIES THAT ACCOMPANY THE VULT WIND SPEEDS USED IN THIS DOCUMENT, SEE SECTION 26.7 OF ASCE 7

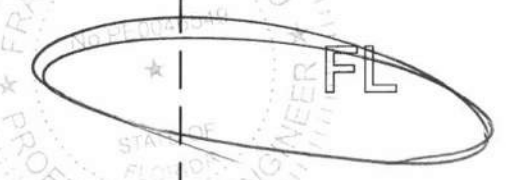

ENGINEERING EXPRESS

POSTAL ADDRESS:
401 W. ATLANTIC AVE R10 BOX 219
DELRAY BEACH, FL 33444
ENGINEERINGEXPRESS.COM

RHEEM SALES COMPANY

5600 OLD GREENWOOD RD
FORT SMITH, AR 72917
(770) 351-3000

MECHANICAL UNIT STEEL AND ALUMINUM TIE-DOWN CLIPS
FOR GRADE AND ROOFTOP APPLICATIONS
FBC 7TH EDITION. (2020) | MIAMI-DADE COUNTY NOA

REMARKS	DRWN	CHKD	DATE
INIT ISSUE	JAC	TSB	05/14/15
2017 FBC UPDATE	LAO	FLB	01/12/18
2020 FBC	CCB	RWN	10/19/20
ADD MODEL NOTE	EPR	RWN	03/10/23

COPYRIGHT ENGINEERING EXPRESS®

20-28800GA

SCALE: NTS UNLESS NOTED

1 OF 7

c:\users\eric\engineering\express\production - documents\projects\20-28800 - noa 18-0719.07- wind load cert of mechanical unit\wp\2020 fbc\20-28800f - noa dwg.dwg 3/16/2023 4:01 PM ERIC

RHEEM SALES COMPANY, INC.

WIND LOAD CERTIFICATION OF MECHANICAL UNIT CABINETY AND STEEL/ALUMINUM TIE-DOWN CLIPS: AT GRADE MOUNTED APPLICATIONS

FRANK BENNARDO, P.E.
PE# 0046549 CA# 9885

MARCH 16, 2023

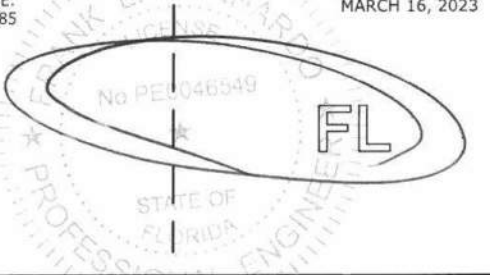

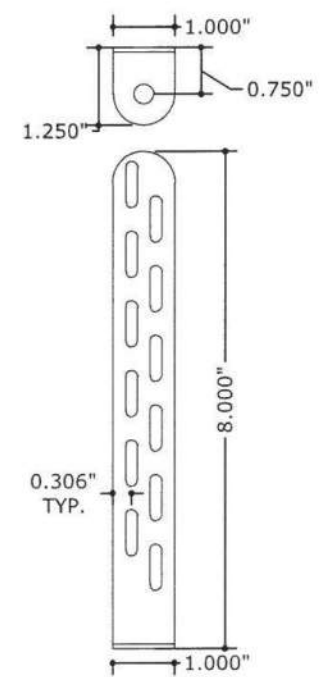
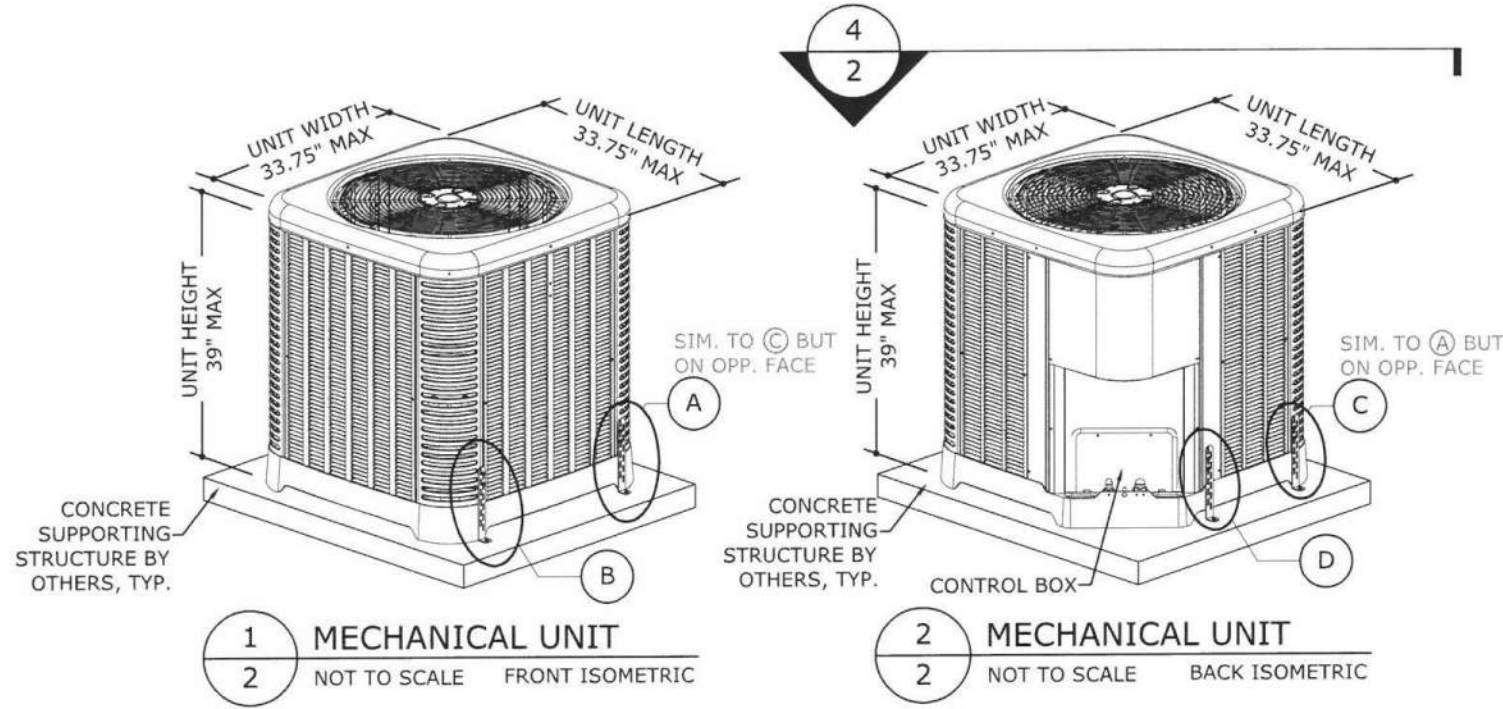

TIE-DOWN BRACKET
 MIAMI TECH CLIP: 14GA (0.07")
 ASTM A653 Fu=90 KSI STEEL (CUTD8) OR 0.080" 5052-H32 ALUMINUM (CUTDA8), MIAMI TECH KIT # RRCUTDSMK OR RRCUTDASMK

THESE ISOMETRICS ARE INTENDED FOR DIAGRAMMATICAL PURPOSES ONLY; ALTERNATE RHEEM UNITS MAY VARY IN APPEARANCE

(2)-#10 SMS PER BRACKET FOR UNITS UP TO 35" TALL. (3)-#10 SMS PER BRACKET FOR UNITS UP TO 39" TALL (ONLY (2) SMS SHOWN BELOW)

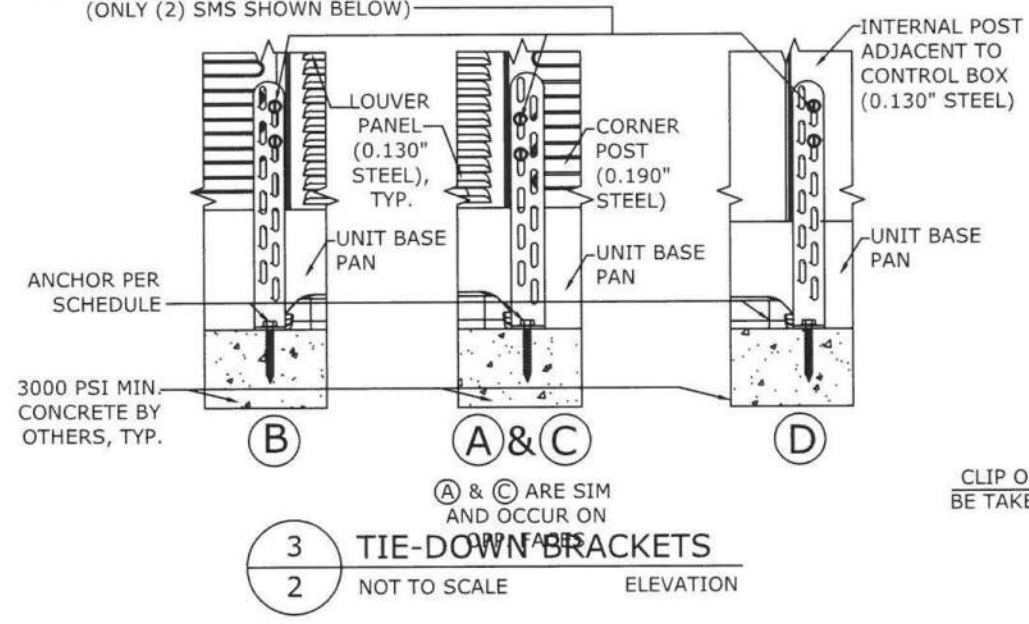

3 TIE-DOWN BRACKETS
 2 NOT TO SCALE ELEVATION

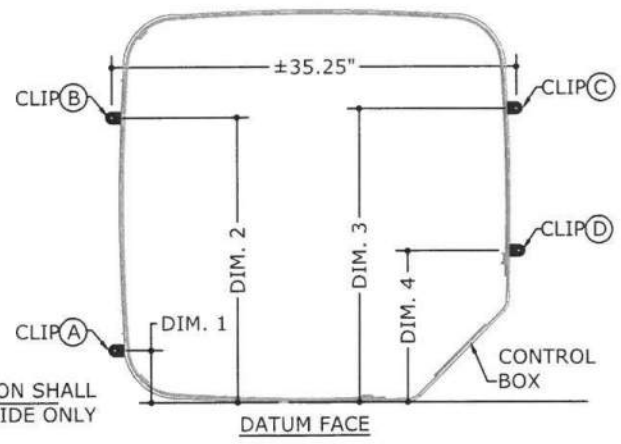

4 TIE-DOWN BRACKET LAYOUT
 2 NOT TO SCALE PLAN

ANCHOR SCHEDULE:

SUBSTRATE	DESCRIPTION
CONCRETE: (4" THICK MIN, 3000 PSI MIN.)	(1)-1/4"Ø STAINLESS STEEL ITW BUILDDEX TAPCON, 1 3/4" FULL EMBED TO CONCRETE, 2 1/2" MIN. EDGE DISTANCE, 3" MIN. SPACING TO ANY ADJACENT ANCHOR.

TIE-DOWN BRACKET OFFSETS:

DIM. 1	4.50" MAX OFFSET FROM DATUM FACE
DIM. 2	28.00" MIN OFFSET FROM DATUM FACE
DIM. 3	29.00" MIN OFFSET FROM DATUM FACE
DIM. 4	13.00" MAX OFFSET FROM DATUM FACE

ENGINEERING EXPRESS®

POSTAL ADDRESS:
 401 W. ATLANTIC AVE R10 BOX 219
 DELRAY BEACH, FL 33444
 ENGINEERINGEXPRESS.COM

RHEEM SALES COMPANY
 5600 OLD GREENWOOD RD
 FORT SMITH, AR 72917
 (770) 351-3000

MECHANICAL UNIT STEEL AND ALUMINUM TIE-DOWN CLIPS FOR GRADE AND ROOFTOP APPLICATIONS
 FBC 7TH EDITION. (2020) | MIAMI-DADE COUNTY NOA

DRWN	CHKD	DATE
JAC	TSB	05/14/15
LAO	FLB	01/12/18
CCB	RWN	10/19/20
EPR	RWN	03/10/23

REMARKS:
 2017 FBC UPDATE
 2020 FBC
 ADD MODEL NOTE

20-28800GB

SCALE: NTS UNLESS NOTED

2

OF 7

RHEEM SALES COMPANY, INC.

WIND LOAD CERTIFICATION OF MECHANICAL UNIT CABINETY AND STEEL/ALUMINUM TIE-DOWN CLIPS: AT GRADE MOUNTED APPLICATIONS

FRANK BENNARDO, P.E.
PE# 0046549 CA# 9885

MARCH 16, 2023

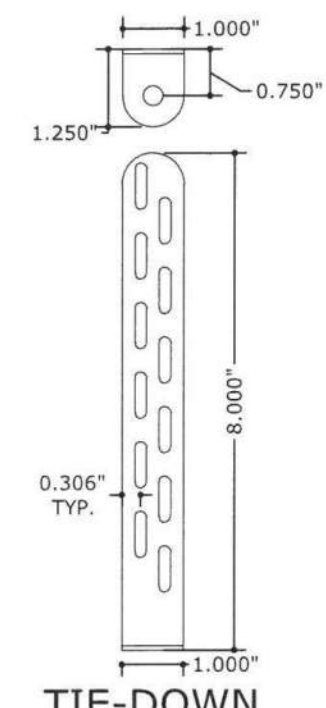
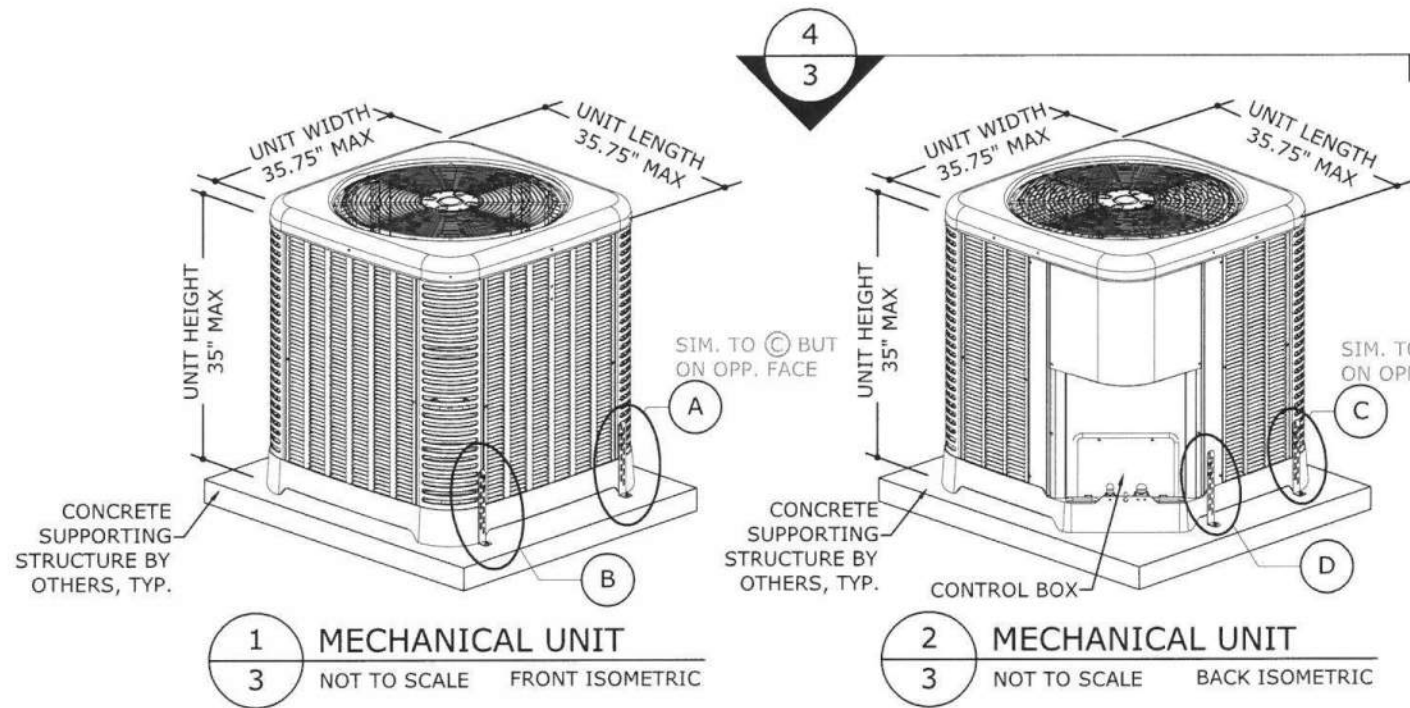
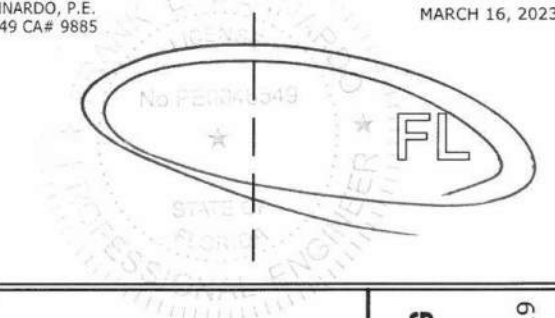

TIE-DOWN BRACKET
MIAMI TECH CLIP: 14GA (0.07")
ASTM A653 Fu=90 KSI STEEL (CUTD8) OR 0.080" 5052-H32 ALUMINUM (CUTDA8), MIAMI TECH KIT # RRCUTDSMK OR RRCUTDASMK

THESE ISOMETRICS ARE INTENDED FOR DIAGRAMMATICAL PURPOSES ONLY; ALTERNATE RHEEM UNITS MAY VARY IN APPEARANCE

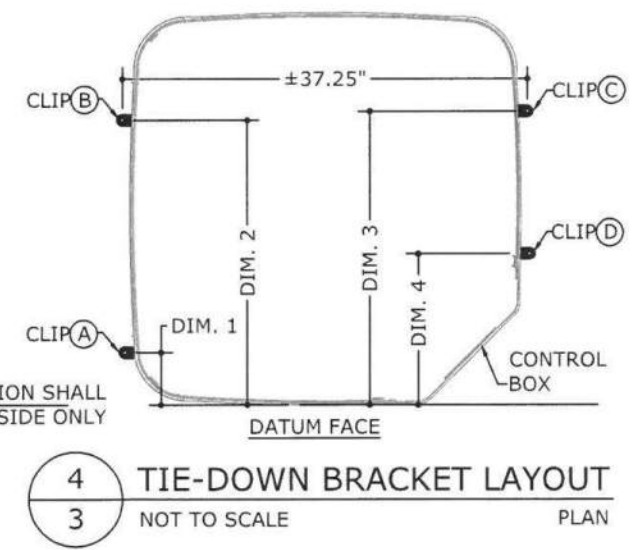
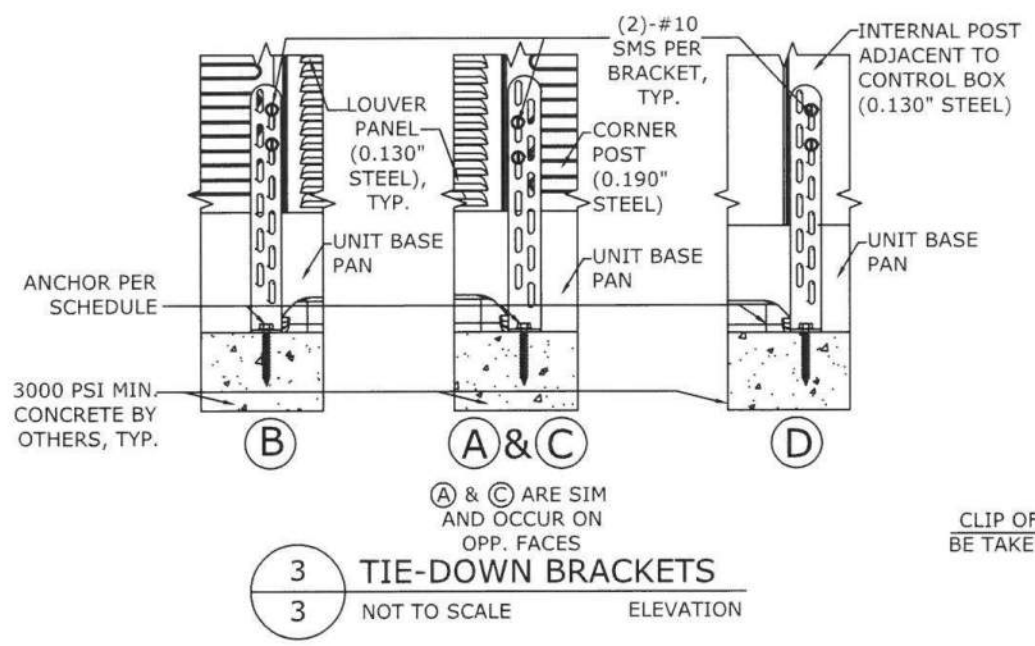

ANCHOR SCHEDULE:

SUBSTRATE	DESCRIPTION
CONCRETE: (4" THICK MIN, 3000 PSI MIN.)	(1)-1/4"Ø STAINLESS STEEL ITW BUILDDEX TAPCON, 1 3/4" FULL EMBED TO CONCRETE, 2 1/2" MIN. EDGE DISTANCE, 3" MIN. SPACING TO ANY ADJACENT ANCHOR.

TIE-DOWN BRACKET OFFSETS:

DIM. 1	4.50" MAX OFFSET FROM DATUM FACE
DIM. 2	30.00" MIN OFFSET FROM DATUM FACE
DIM. 3	31.00" MIN OFFSET FROM DATUM FACE
DIM. 4	13.00" MAX OFFSET FROM DATUM FACE

PRODUCT REVISED
as complying with the Florida
Building Code
NOA-No. 23-0328.04
Expiration Date 02/25/2026
By *[Signature]*
Miami-Dade Product Control

ENGINEERING EXPRESS
POSTAL ADDRESS:
401 W. ATLANTIC AVE R10 BOX 219
DELRAY BEACH, FL 33444
ENGINEERINGEXPRESS.COM

RHEEM SALES COMPANY
5600 OLD GREENWOOD RD
FORT SMITH, AR 72917
(770) 351-3000
MECHANICAL UNIT STEEL AND ALUMINUM TIE-DOWN CLIPS
FOR GRADE AND ROOFTOP APPLICATIONS
FBC 7TH EDITION. (2020) | MIAMI-DADE COUNTY NOA

REMARKS	DRWN	CHKD	DATE
INIT ISSUE	JAC	TSB	05/14/15
2017 FBC UPDATE	LAO	FLB	01/12/18
2020 FBC	CCB	RWN	10/19/20
ADD MODEL NOTE	EPR	RWN	03/10/23

COPYRIGHT ENGINEERING EXPRESS®

20-28800GC
SCALE: NTS UNLESS NOTED
3 OF 7

c:\Users\eric\engineering\express\production - documents\projects\20-28800 - noa 18-0719.07- wind load cert of mechanical unit\wp\2020 fbc\20-28800f - noa.dwg.dwg 3/16/2023 4:01 PM ERIC

RHEEM SALES COMPANY, INC.

WIND LOAD CERTIFICATION OF MECHANICAL UNIT CABINETY AND STEEL/ALUMINUM TIE-DOWN CLIPS: AT GRADE MOUNTED APPLICATIONS

FRANK BENNARDO, P.E.
PE# 0046549 CA# 9885

MARCH 16, 2023

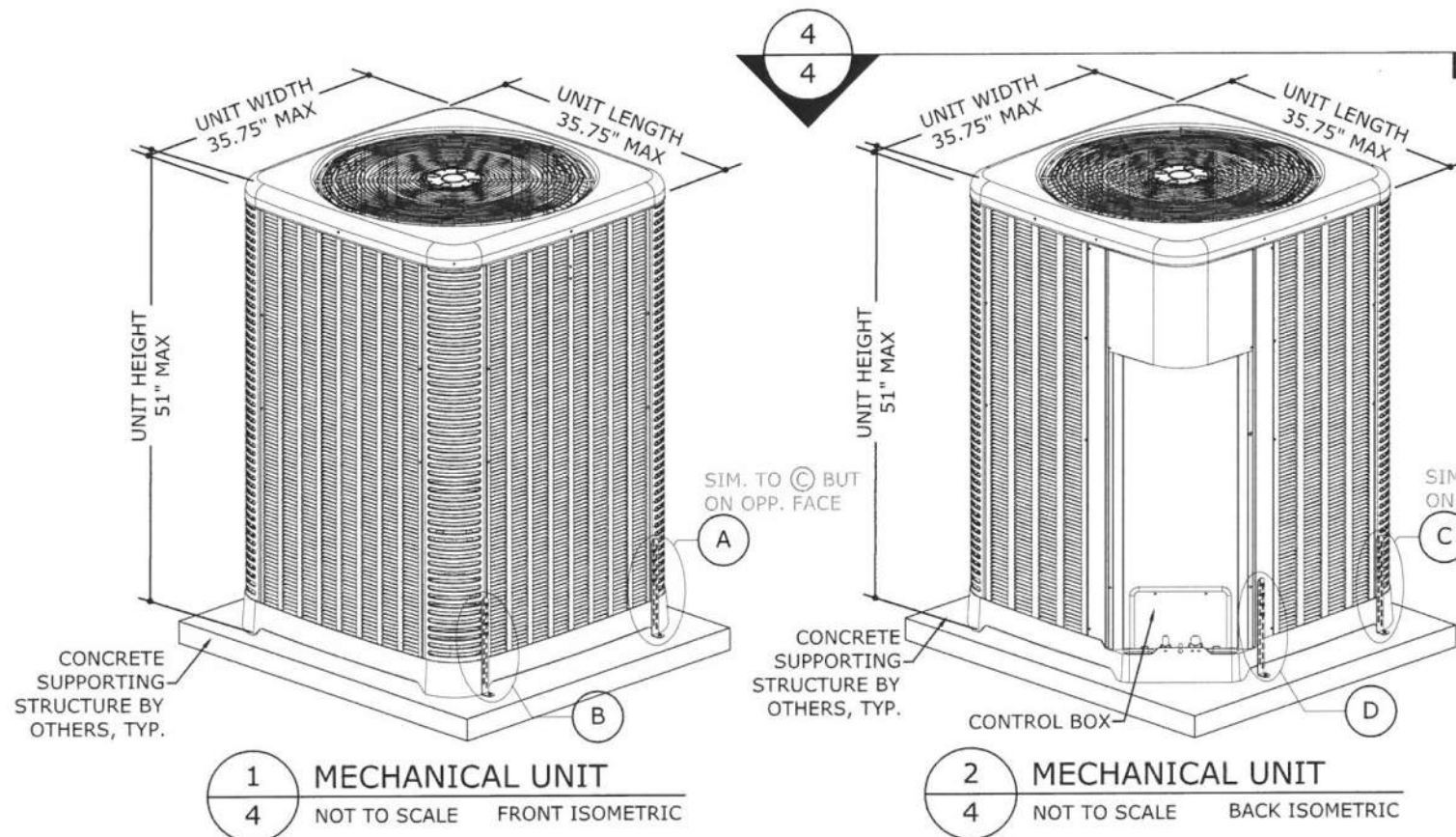
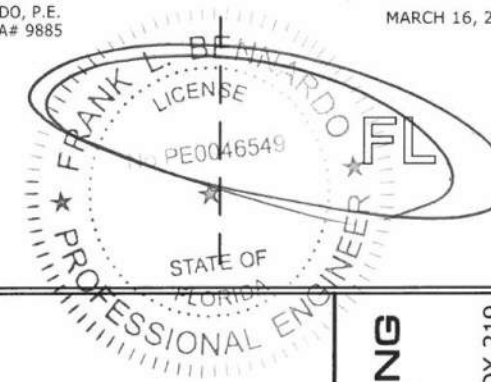

THESE ISOMETRICS ARE INTENDED FOR DIAGRAMMATICAL PURPOSES ONLY; ALTERNATE RHEEM UNITS MAY VARY IN APPEARANCE

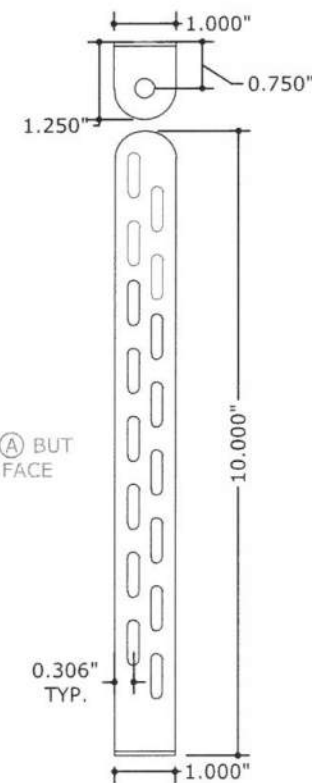

TIE-DOWN BRACKET

MIAMI TECH CLIP: 14GA (0.07") ASTM A653
Fu=90 KSI STEEL (CUTD10) OR 0.080"
5052-H32 ALUMINUM (CUTDA10), MIAMI
TECH KIT # RRCUTDLK OR RRCUTDALK

ANCHOR SCHEDULE:

SUBSTRATE	DESCRIPTION
CONCRETE: (4" THICK MIN, 3000 PSI MIN.)	(1)-1/4"Ø CARBON STEEL SIMPSON STRONG BOLT 2, 1 1/2" MIN EMBED TO CONCRETE, 3" MIN. EDGE DISTANCE, 3" MIN. SPACING TO ANY ADJACENT ANCHOR.
	(1)-1/4"Ø CARBON STEEL DEWALT WEDGE BOLT+, 2 1/2" MIN EMBED TO CONCRETE, 3" MIN. EDGE DISTANCE, 3" MIN. SPACING TO ANY ADJACENT ANCHOR.

SUPPORTING CONCRETE SUBSTRATE DEPTH SHALL BE A MINIMUM 1.5xANCHOR EMBED.
EITHER ANCHOR FROM THIS SCHEDULE MAY BE USED FOR INSTALLATION.

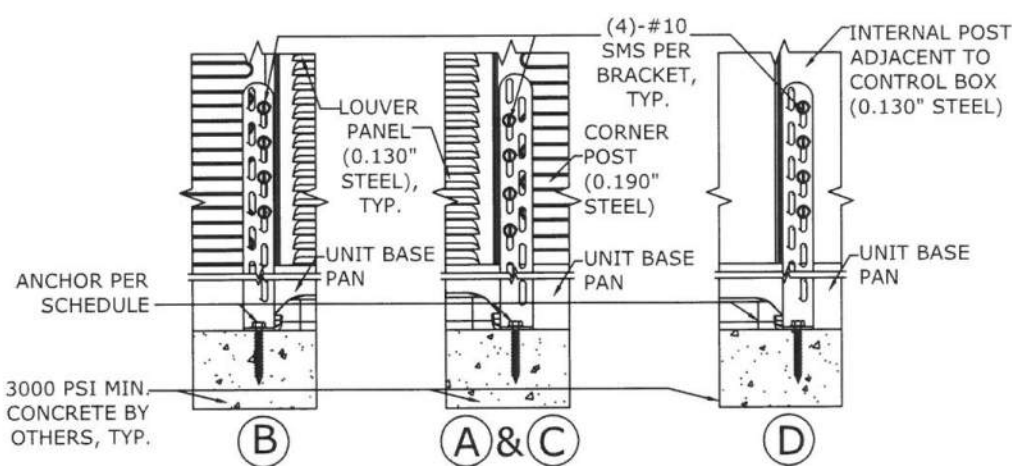

3 TIE-DOWN BRACKETS
4 NOT TO SCALE ELEVATION

4 TIE-DOWN BRACKET LAYOUT
4 NOT TO SCALE PLAN

TIE-DOWN BRACKET OFFSETS:

DIM. 1	4.50" MAX OFFSET FROM DATUM FACE
DIM. 2	30.00" MIN OFFSET FROM DATUM FACE
DIM. 3	31.00" MIN OFFSET FROM DATUM FACE
DIM. 4	13.00" MAX OFFSET FROM DATUM FACE

ENGINEERING EXPRESS
POSTAL ADDRESS:
401 W. ATLANTIC AVE R10 BOX 219
DELRAY BEACH, FL 33444
ENGINEERINGEXPRESS.COM

RHEEM SALES COMPANY
5600 OLD GREENWOOD RD
FORT SMITH, AR 72917
(770) 351-3000
MECHANICAL UNIT STEEL AND ALUMINUM TIE-DOWN CLIPS
FOR GRADE AND ROOFTOP APPLICATIONS
FBC 7TH EDITION. (2020) | MIAMI-DADE COUNTY NOA

DRWN	CHKD	DATE
JAC	TSB	05/14/15
LAO	FLB	01/12/18
CCB	RWN	10/19/20
EPR	RWN	03/10/23

20-28800GD
SCALE: NTS UNLESS NOTED

RHEEM SALES COMPANY, INC.

WIND LOAD CERTIFICATION OF MECHANICAL UNIT CABINETRY AND STEEL TIE-DOWN CLIPS: ROOF MOUNTED APPLICATIONS

NON-SITE-SPECIFIC STRUCTURAL PERFORMANCE EVALUATION. A DESIGN PROFESSIONAL SHALL BE RESPONSIBLE FOR CERTIFYING THE APPLICATION OF THIS INFORMATION TO ANY SITE-SPECIFIC LOCATION.

FRANK BENNARDO, P.E.
PE# 0046549 CA# 9885

MARCH 16, 2023

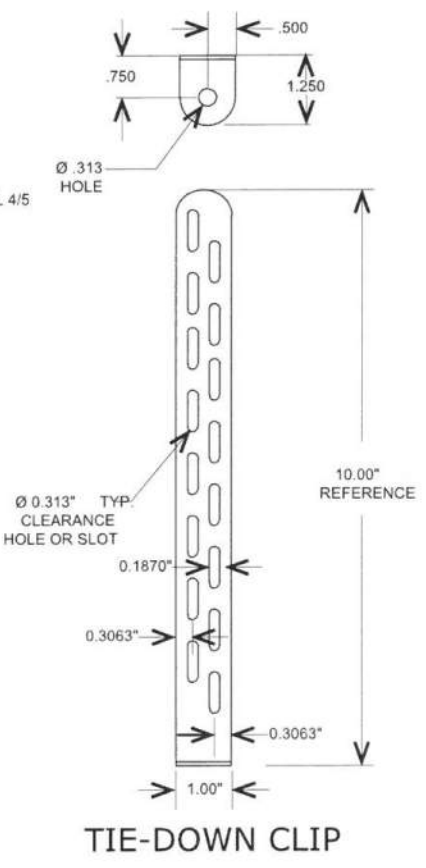
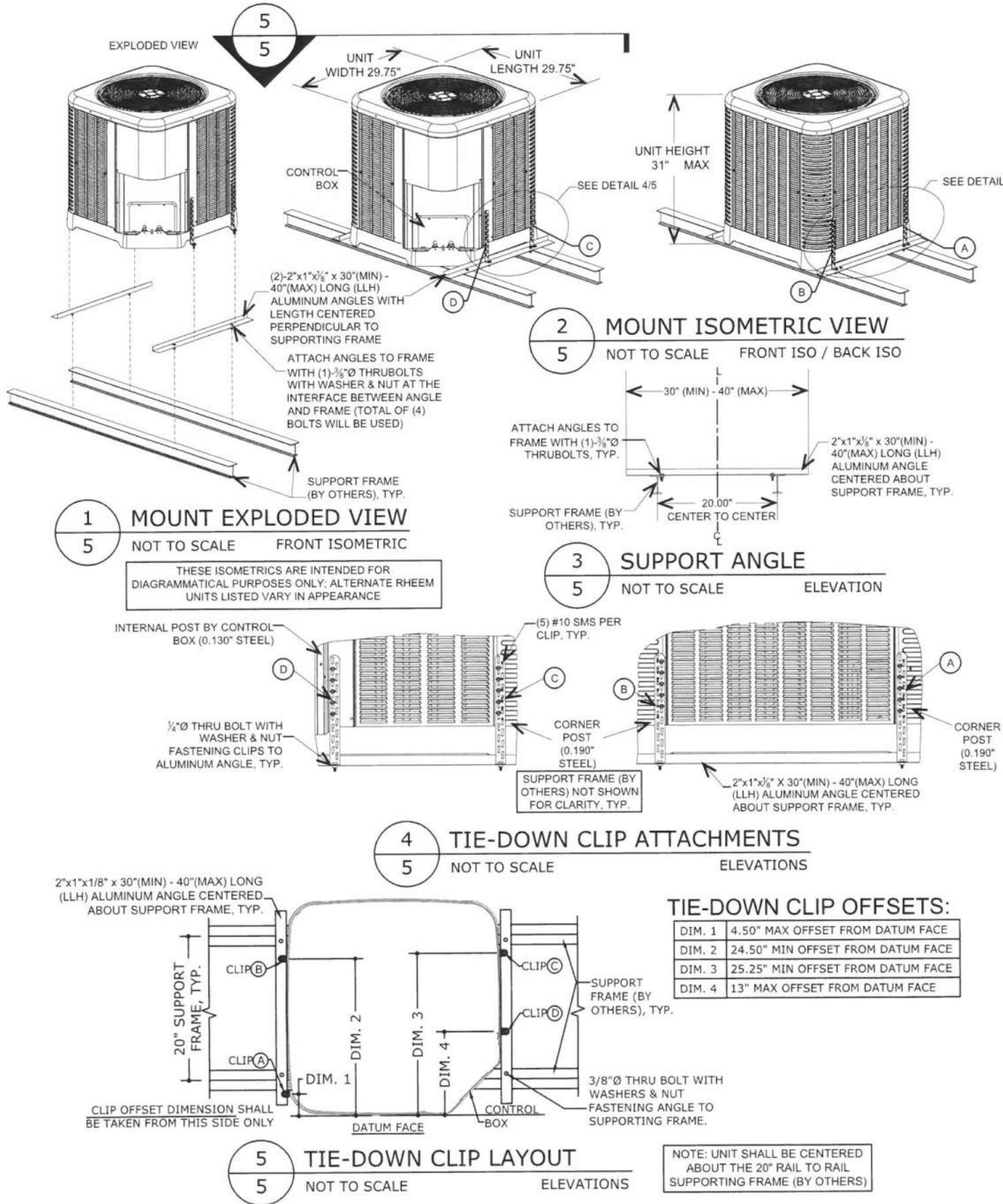
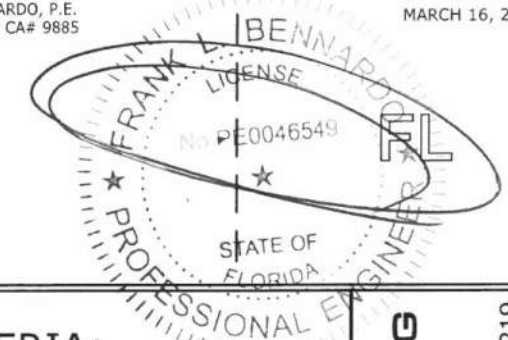

APPROVED DESIGN CRITERIA:

200 PSF LATERAL WIND LOAD	100 PSF UPLIFT WIND LOAD (CONCURRENT)
---------------------------	---------------------------------------

DESIGN NOTES:

SITE-SPECIFIC PRESSURE REQUIREMENTS AS DETERMINED IN ACCORDANCE WITH ASCE 7 AND CHAPTER 16 OF THE FLORIDA BUILDING CODE SHALL BE LESS THAN OR EQUAL TO THE DESIGN PRESSURE CAPACITY VALUES LISTED HEREIN FOR ANY ASSEMBLY AS SHOWN. DESIGN PRESSURE REQUIREMENTS SHALL BE DETERMINED BY A REGISTERED DESIGN PROFESSIONAL ON A JOB-SPECIFIC BASIS IN ACCORDANCE WITH THE GOVERNING CODE.

GENERAL NOTES:

- THIS SYSTEM HAS BEEN DESIGNED AND SHALL BE FABRICATED IN ACCORDANCE WITH THE REQUIREMENTS OF THE FLORIDA BUILDING CODE SEVENTH EDITION (2020). THIS SYSTEM MAY BE USED WITHIN AND OUTSIDE THE HIGH VELOCITY HURRICANE ZONE. THIS DESIGN IS NOT INTENDED TO CERTIFY IMPACT RESISTANCE OF THE MECHANICAL UNIT CABINETRY.
- NO 33-1/3% INCREASE IN ALLOWABLE STRESS HAS BEEN USED IN THE DESIGN OF THIS SYSTEM.
- DESIGN & CERTIFICATION OF THE UNIT CABINETRY IS APPROVED THROUGH TEST REPORT#0323.01-15 BY AMERICAN TEST LAB OF SOUTH FLORIDA.
- ALL MODELS WITH THE MAXIMUM DIMENSIONS, MINIMUM WEIGHT (120 LB MINIMUM), AND MINIMUM MATERIAL STRENGTH, THICKNESS, AND FASTENERS SHOWN HEREIN ARE COVERED UNDER THIS NOA.** MODELS SHALL CONFORM TO THE LIMITATIONS STATED HEREIN. ALL MECHANICAL SPECIFICATIONS (CLEAR SPACE, TONNAGE, ETC.) SHALL BE AS PER MANUFACTURER RECOMMENDATIONS AND ARE THE EXPRESS RESPONSIBILITY OF THE CONTRACTOR.
- ALL SHEET METAL SCREWS USED TO FASTEN CLIPS TO MECHANICAL UNITS SHALL BE #10 (14 MIN THREADS PER INCH) GRADE 5 STEEL OR EQUIVALENT ONLY. BOLTS USED TO FASTEN ALUMINUM ANGLES TO SUPPORTING FRAME (BY OTHERS) SHALL BE ASTM F593 410 STAINLESS STEEL OR EQUIVALENT AND SHALL UTILIZE SAE GRADE WASHERS & NUTS. PROVIDE (5) PITCHES MINIMUM PAST THE THREAD PLANE FOR SHEET METAL SCREWS. ALL FASTENERS SHALL HAVE APPROPRIATE CORROSION PROTECTION TO PREVENT ELECTROLYSIS. ALL FASTENER CONNECTIONS TO ALUMINUM SHALL PROVIDE 2xDIAMETER EDGE DISTANCE.
- ALUMINUM ANGLES SPECIFIED HEREIN SHALL BE 6061-T6 ALUMINUM ONLY.
- CONNECTIONS TO THE SUPPORTING FRAME (BY OTHERS) CONSIDER A FRAME MEMBER THAT IS 6061-T6 MIN ALUMINUM WITH A MINIMUM 0.094" THICK FLANGE AT ATTACHMENT POINT. PERFORMANCE OF THE RAIL AS A STRUCTURAL MEMBER TO SUPPORT THE UNIT ASSEMBLY SHALL BE PER SEPARATE CERTIFICATION.
- THE CONTRACTOR IS RESPONSIBLE TO INSULATE ALL MEMBERS FROM DISSIMILAR MATERIALS TO PREVENT ELECTROLYSIS.
- ELECTRICAL GROUND, WHEN REQUIRED, TO BE DESIGNED & INSTALLED BY OTHERS.
- THE ADEQUACY OF ANY EXISTING STRUCTURE TO WITHSTAND SUPERIMPOSED LOADS SHALL BE VERIFIED BY THE ONSITE DESIGN PROFESSIONAL AND IS NOT INCLUDED IN THIS CERTIFICATION. EXCEPT AS EXPRESSLY PROVIDED HEREIN, NO ADDITIONAL CERTIFICATIONS OR AFFIRMATIONS ARE INTENDED.
- THE SYSTEM DETAILED HEREIN IS GENERIC AND DOES NOT PROVIDE INFORMATION FOR A SPECIFIC SITE. FOR SITE CONDITIONS DIFFERENT FROM THE CONDITIONS DETAILED HEREIN, A LICENSED ENGINEER OR REGISTERED ARCHITECT SHALL PREPARE SITE SPECIFIC DOCUMENTS FOR USE IN CONJUNCTION WITH THIS DOCUMENT.
- WATER-TIGHTNESS OF EXISTING HOST SUBSTRATE SHALL BE THE FULL RESPONSIBILITY OF THE INSTALLING CONTRACTOR. CONTRACTOR SHALL ENSURE THAT ANY REMOVED OR ALTERED WATERPROOFING MEMBRANE IS RESTORED AFTER FABRICATION AND INSTALLATION OF STRUCTURE PROPOSED HEREIN. THIS ENGINEER SHALL NOT BE RESPONSIBLE FOR ANY WATERPROOFING OR LEAKAGE ISSUES WHICH MAY OCCUR AS WATER-TIGHTNESS SHALL BE THE FULL RESPONSIBILITY OF THE INSTALLING CONTRACTOR.



RHEEM SALES COMPANY
5600 OLD GREENWOOD RD
FORT SMITH, AR 72917
(770) 351-3000

POSTAL ADDRESS:
401 W. ATLANTIC AVE R10 BOX 219
DELRAY BEACH, FL 33444
ENGINEERINGEXPRESS.COM

REMARKS	DRWN	CHKD	DATE
INIT ISSUE	JAC	TSB	05/14/15
2017 FBC UPDATE	LAO	FLB	01/12/18
2020 FBC	CCB	RWN	10/19/20
ADD MODEL NOTE	EPR	RWN	03/10/23

20-28800RE

SCALE: NTS UNLESS NOTED

5 OF 7

RHEEM SALES COMPANY, INC.

WIND LOAD CERTIFICATION OF MECHANICAL UNIT CABINETRY AND STEEL TIE-DOWN CLIPS: ROOF MOUNTED APPLICATIONS

FRANK BENNARDO, P.E.
PE# 0046549 CA# 9885

MARCH 16, 2023

FRANK L. BENNARDO, P.E.
LICENSE
No. PE0046549
STATE OF FLORIDA
PROFESSIONAL ENGINEER

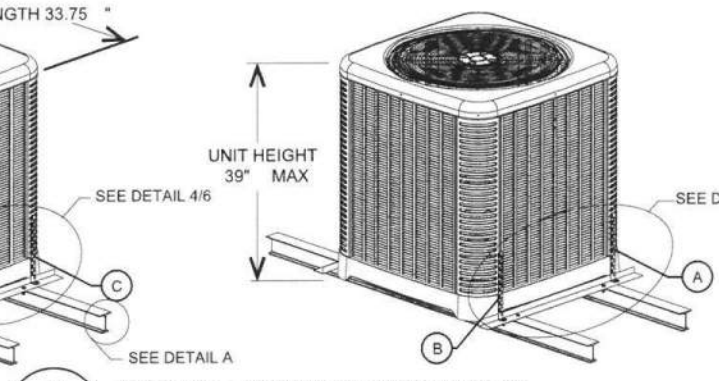
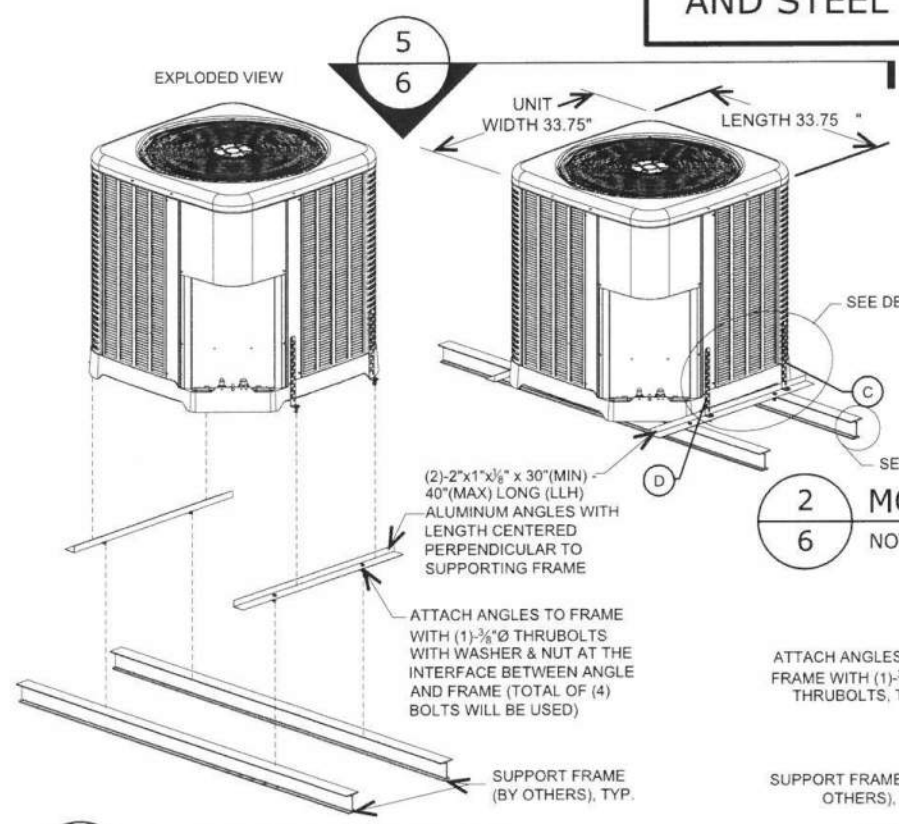

2 MOUNT ISOMETRIC VIEW
6 NOT TO SCALE FRONT ISO / BACK ISO

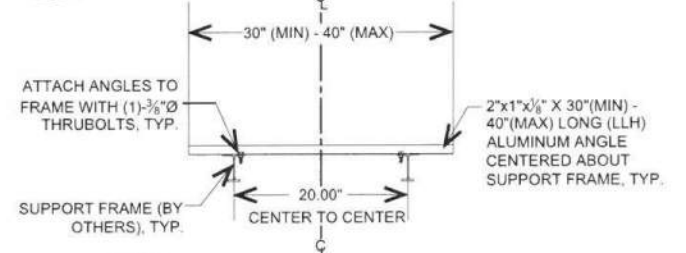

3 SUPPORT ANGLE
6 NOT TO SCALE ELEVATION

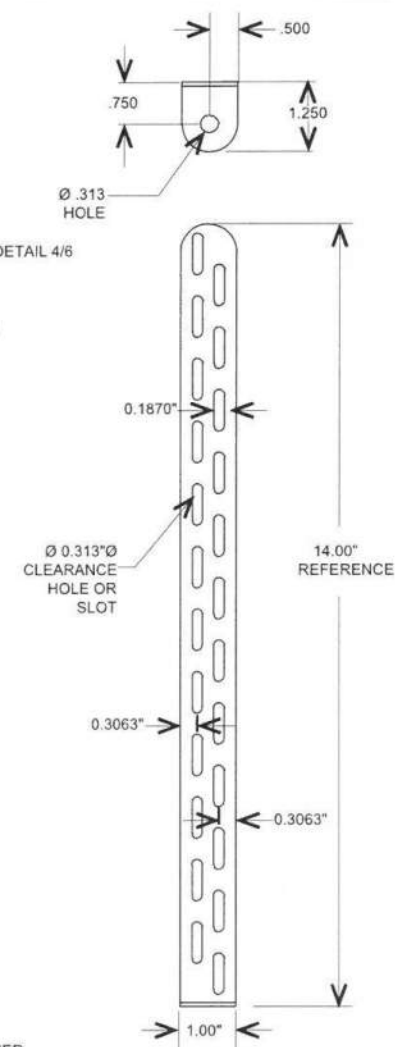

TIE-DOWN CLIP
MIAMI TECH CLIP: 12GA (0.09") ASTM A653 Fu=90 KSI STEEL (CUTD14), MIAMI TECH KIT # RRCUTD34K

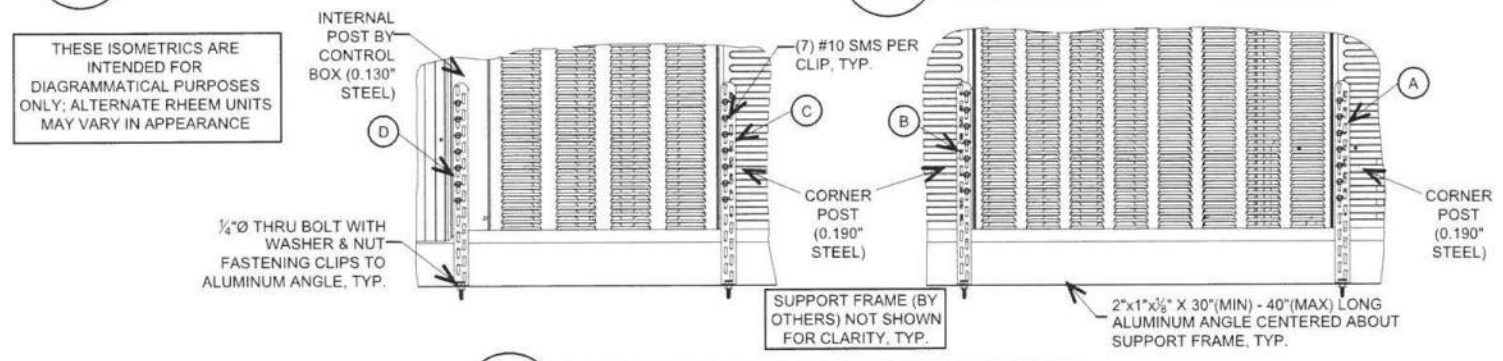

4 TIE-DOWN CLIP ATTACHMENTS
6 NOT TO SCALE ELEVATIONS

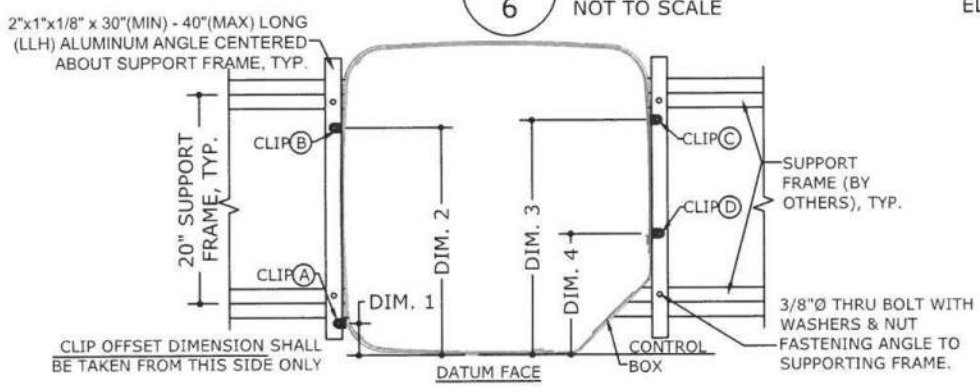

5 TIE-DOWN CLIP LAYOUT
6 NOT TO SCALE ELEVATIONS

TIE-DOWN CLIP OFFSETS:

DIM. 1	4.50" MAX OFFSET FROM DATUM FACE
DIM. 2	28.00" MIN OFFSET FROM DATUM FACE
DIM. 3	29.00" MIN OFFSET FROM DATUM FACE
DIM. 4	13.00" MAX OFFSET FROM DATUM FACE

NOTE: UNIT SHALL BE CENTERED ABOUT THE 20" RAIL TO RAIL SUPPORTING FRAME (BY OTHERS)

PRODUCT REVISED
as complying with the Florida Building Code
NOA-No. 23-0328.04
Expiration Date 02/25/2026
By *R. H. Hens*
Miami-Dade Product Control

ENGINEERING EXPRESS

POSTAL ADDRESS:
401 W. ATLANTIC AVE R10 BOX 219
DELRAY BEACH, FL 33444
ENGINEERINGEXPRESS.COM

RHEEM SALES COMPANY

5600 OLD GREENWOOD RD
FORT SMITH, AR 72917
(770) 351-3000

MECHANICAL UNIT STEEL AND ALUMINUM TIE-DOWN CLIPS FOR GRADE AND ROOFTOP APPLICATIONS
FBC 7TH EDITION. (2020) | MIAMI-DADE COUNTY NOA

REMARKS	DRWN	CHKD	DATE
INIT ISSUE	JAC	TSB	05/14/15
2017 FBC UPDATE	LAO	FLB	01/12/18
2020 FBC	CCB	RWN	10/19/20
ADD MODEL NOTE	EPR	RWN	03/10/23

COPYRIGHT ENGINEERING EXPRESS®

20-28800RE

SCALE: NTS UNLESS NOTED

c:\users\eric\engineering\express\production - documents\projects\20-28800 - noa 18-0719.07- wind load cert of mechanical unit\wp\2020 fbc\20-28800f - noa.dwg.dwg

ERIC

3/16/2023 4:02 PM

RHEEM SALES COMPANY, INC.

WIND LOAD CERTIFICATION OF MECHANICAL UNIT CABINETRY AND STEEL TIE-DOWN CLIPS: ROOF MOUNTED APPLICATIONS

FRANK BENNARDO, P.E.
PE# 0046549 CA# 9885

MARCH 16, 2023

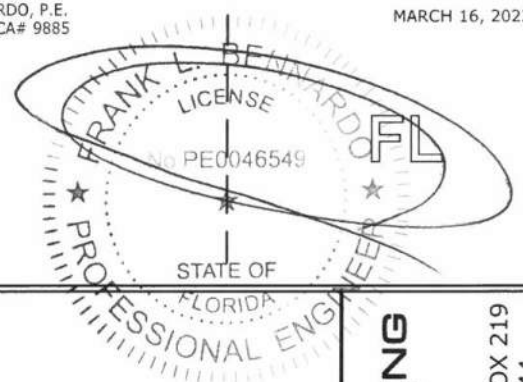

c:\users\eric\engineering\express\production - documents\projects\20-120-28800 - noa 18-0719-07- wind load cert of mechanical unit\wp\2020 fbc\20-28800f - noa dwg.dwg

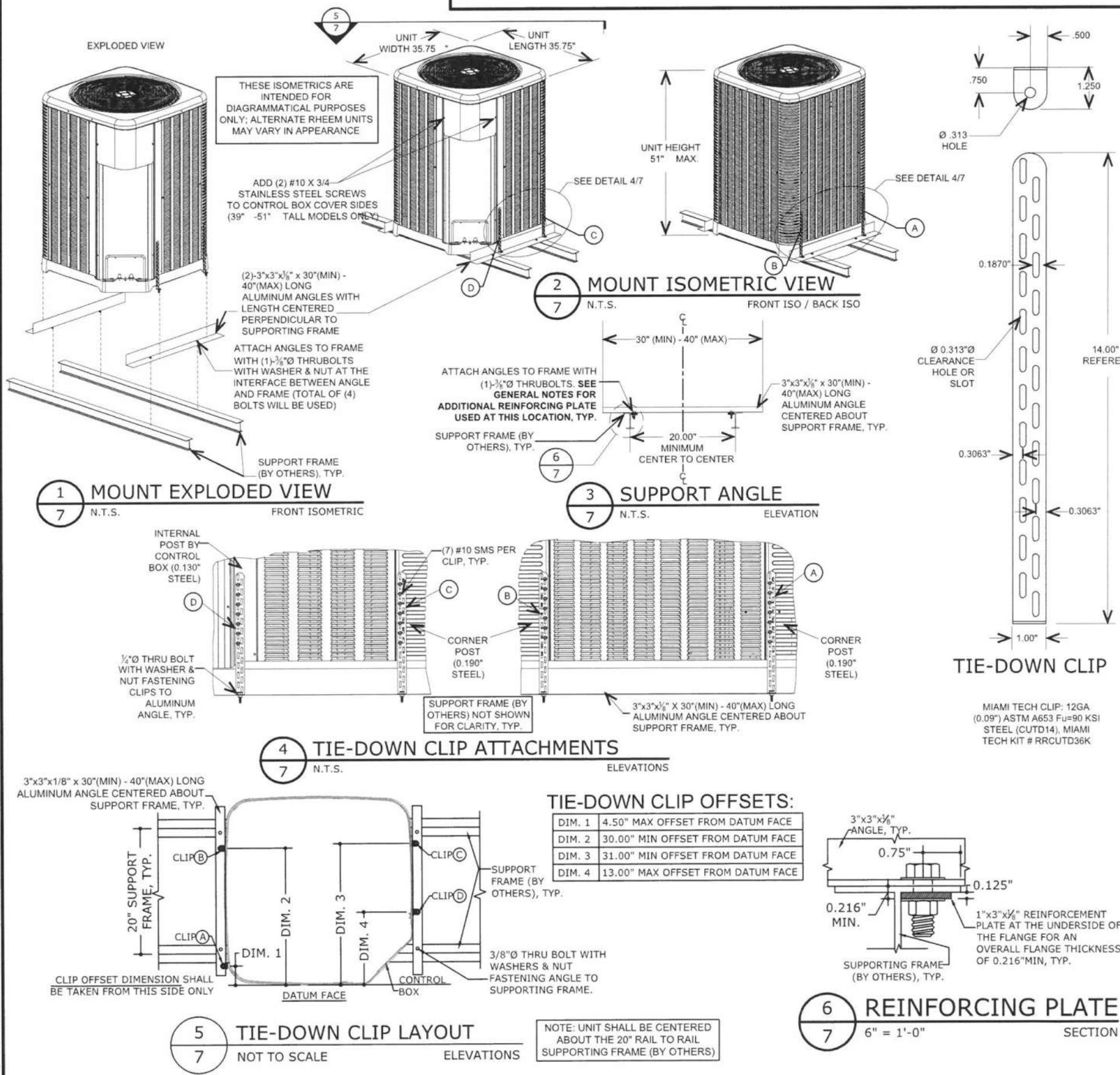

PRODUCT REVISED
as complying with the Florida Building Code
NOA-No. 23-0328.04
Expiration Date 02/25/2026

By *[Signature]*
Miami-Dade Product Control

RHEEM SALES COMPANY
5600 OLD GREENWOOD RD
FORT SMITH, AR 72917
(770) 351-3000

ENGINEERING EXPRESS

POSTAL ADDRESS:
401 W. ATLANTIC AVE R10 BOX 219
DELRAY BEACH, FL 33444
ENGINEERINGEXPRESS.COM

MECHANICAL UNIT STEEL AND ALUMINUM TIE-DOWN CLIPS FOR GRADE AND ROOFTOP APPLICATIONS
FBC 7TH EDITION. (2020) | MIAMI-DADE COUNTY NOA

DRWN	CHKD	DATE
JAC	TSB	05/14/15
LAO	FLB	01/12/18
CCB	RWN	10/19/20
EPR	RWN	03/10/23

REMARKS

INIT ISSUE

2017 FBC UPDATE

2020 FBC

ADD MODEL NOTE

COPYRIGHT ENGINEERING EXPRESS®

20-28800RE

SCALE: NTS UNLESS NOTED

7