



Featuring  
Earth-Friendly  
R-410A Refrigerant

**R-410A**  
earth friendly refrigerant



## 14PJL SERIES

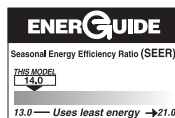

## 14 SEER HEAT PUMPS

### Features

- Coils constructed with copper tubing and enhanced aluminum fins.
- Strong, attractive cabinet—louvered design protects the coil from damage.
- Expansion Valves with Internal Check Valve—Provides for quieter refrigerant metering.
- Demand Defrost Control
- Non-Cycling Reversing Valve
- Hot Gas Muffler
- Service Valves
- Grille/motor mount for quiet fan operation.
- Easily accessible control box.
- Bi-Directional Filter Drier (shipped – not installed)
- Certified and rated under A.R.I. Standard 240.
- U.L listed.

### Accessories/Options

- Low Ambient Control (Model No. RXAD-A08)
- Outdoor Thermostats (Model No. RXPT-A01, A02, A03 or A04)
- Heat Pump Monitor (Model No. RXPM-B01)
- Thermostats and Subbases  
(Available through the PROSTOCK® department)
- Compressor Time Delay Control (Model No. RXMD-B01)
- Blower Time Delay Control (Model No. RXMD-C04)  
RXMD-C04 is not required if the outdoor unit is matched with a Rheem Value Series furnace or air handler, or if the furnace or air handler used has a blower off time delay built-in.
- Sound Enclosure\*
- High Pressure Control (Model No. RXAB-A07)
- Start Components\*

\*Available through the PROSTOCK® department.

### Applications

Rheem Value Series remote heat pumps offer comfort and dependability for single, multi-family and light commercial applications.

# Model Identification Number

<b>14</b>	<b>P</b>	<b>J</b>	<b>L</b>	<b>18</b>	<b>A</b>	<b>01</b>
14 SEER	P = HEAT PUMP	VOLTAGE	L = R-410A	NOMINAL COOLING CAPACITY	CABINET	RHEEM VALUE SERIES
	J = 208-230 SINGLE PHASE			18 = 18,000 BTU/HR [5.28 kW] 24 = 24,000 BTU/HR [7.03 kW] 30 = 30,000 BTU/HR [8.79 kW] 36 = 36,000 BTU/HR [10.55 kW] 42 = 42,000 BTU/HR [12.31 kW] 48 = 48,000 BTU/HR [14.07 kW] 60 = 60,000 BTU/HR [17.58 kW]	A = FULL METAL JACKET	

## Performance Data ARI Standard Conditions

Note: Only these combinations of indoor/outdoor units are approved and any other combinations should not be used.

Model Numbers		ARI Cooling Performance							ARI Htg. Performance (70°F 21.0°C) Indoor				
		80°F [26.5°C] DB/67°F [19.5°C] WB Indoor Air 95°F [35.0°C] DB Outdoor Air							Outdoor Air 47°F DB/43°F WB [8.5°C/6.0°C] DOE High Temp.		Outdoor Air 17°F DB/15°F WB [-8.5°C/-9.5°C] DOE Low Temp.		DOE Region IV HSPF
Outdoor Unit 14PJL	Indoor Coil and/or Air Handler	Total Capacity BTU/H [kW]	Net Sens. BTU/H [kW]	Net Latent BTU/H [kW]	EER	SEER	Snd. Rate dB	Indoor CFM [L/s]	BTU/H [kW]	COP	BTU/H [kW]	COP	
Rev. 1/10/2008  18	RHLL-HM2417 (RCSL-H*2417A*) ①	18,600 [5.4]	13,450 [3.9]	5,150 [1.5]	12.00	14.00	76	600 [283]	16,500 [4.8]	3.62	8,300 [2.4]	2.30	8.2
	RCFL-H*2414A*	18,100 [5.3]	12,950 [3.8]	5,150 [1.5]	11.10	13.00	76	600 [283]	17,000 [5.0]	3.36	8,800 [2.6]	2.08	7.7
	RCFL-H*2417A*	18,100 [5.3]	12,950 [3.8]	5,150 [1.5]	11.10	13.00	76	600 [283]	17,000 [5.0]	3.36	8,800 [2.6]	2.08	7.7
	RBHP-17 (RCHL-24A2)	17,800 [5.2]	12,900 [3.8]	4,900 [1.4]	12.00	14.00	76	600 [283]	16,500 [4.8]	3.64	9,100 [2.7]	2.44	8.2
	17AHL24HM (RCSL-H*2417A*)	18,600 [5.4]	13,450 [3.9]	5,150 [1.5]	12.00	14.00	76	600 [283]	16,500 [4.8]	3.62	8,300 [2.4]	2.30	8.2
	17AHS18HM (RCSL-H*2417A*)	18,300 [5.4]	13,250 [3.9]	5,050 [1.5]	11.50	13.00	76	600 [283]	16,800 [4.9]	3.42	8,700 [2.5]	2.10	7.7
	RHSL-HM1817 (RCSL-H*2417A*)	18,300 [5.4]	13,250 [3.9]	5,050 [1.5]	11.50	13.00	76	600 [283]	16,800 [4.9]	3.42	8,700 [2.5]	2.10	7.7
24	RHLL-HM2417 (RCSL-H*2417A*) ①	24,800 [7.3]	17,650 [5.2]	7,150 [2.1]	12.00	14.00	74	800 [378]	22,200 [6.5]	3.72	13,100 [3.8]	2.36	8.5
	RCFL-H*2414A*	24,200 [7.1]	17,050 [5.0]	7,150 [2.1]	10.75	13.00	74	800 [378]	22,800 [6.7]	3.44	13,800 [4.0]	2.22	7.7
	RCFL-H*2417A*	24,200 [7.1]	17,050 [5.0]	7,150 [2.1]	10.75	13.00	74	800 [378]	22,800 [6.7]	3.44	13,800 [4.0]	2.22	7.7
	RBHP-17 (RCHL-24A2)	22,400 [6.6]	15,850 [4.6]	6,550 [1.9]	11.00	13.00	74	800 [378]	22,200 [6.5]	3.60	14,500 [4.2]	2.54	7.7
	17AHL24HM (RCSL-H*2417A*)	24,800 [7.3]	17,650 [5.2]	7,150 [2.1]	12.00	14.00	74	800 [378]	22,200 [6.5]	3.72	13,100 [3.8]	2.36	8.5
	17AHS24HM (RCSL-H*2417A*)	24,200 [7.1]	17,050 [5.0]	7,150 [2.1]	10.90	13.00	74	800 [378]	22,800 [6.7]	3.50	13,600 [4.0]	2.24	7.7
	RHSL-HM2417 (RCSL-H*2417A*)	24,200 [7.1]	17,050 [5.0]	7,150 [2.1]	10.90	13.00	74	800 [378]	22,800 [6.7]	3.50	13,600 [4.0]	2.24	7.7
30	RHLL-HM3617 (RCSL-H*3617A*) ①	28,800 [8.4]	21,650 [6.3]	7,150 [2.1]	12.00	14.00	73	1,000 [472]	26,800 [7.9]	3.78	14,400 [4.2]	2.44	8.5
	RCFL-H*3617A*	28,200 [8.3]	21,050 [6.2]	7,150 [2.1]	11.00	13.00	73	1,000 [472]	27,400 [8.0]	3.58	15,000 [4.4]	2.36	7.7
	RCFL-H*3621A*	28,200 [8.3]	21,050 [6.2]	7,150 [2.1]	11.00	13.00	73	1,000 [472]	27,400 [8.0]	3.58	15,000 [4.4]	2.36	7.7
	RBHP-21 (RCHL-36A1)	28,600 [8.4]	21,200 [6.2]	7,400 [2.2]	12.00	14.00	73	1,000 [472]	26,800 [7.9]	3.82	14,500 [4.2]	2.56	8.5
	17AHL36HM (RCSL-H*3617A*)	28,800 [8.4]	21,650 [6.3]	7,150 [2.1]	12.00	14.00	73	1,000 [472]	26,800 [7.9]	3.78	14,400 [4.2]	2.44	8.5
	17AHS30HM (RCSL-H*3617A*)	28,600 [8.4]	21,450 [6.3]	7,150 [2.1]	11.40	13.00	73	1,000 [472]	27,800 [8.1]	3.74	15,600 [4.6]	2.52	7.7
	RHSL-HM3017 (RCSL-H*3617A*)	28,600 [8.4]	21,450 [6.3]	7,150 [2.1]	11.40	13.00	73	1,000 [472]	27,800 [8.1]	3.74	15,600 [4.6]	2.52	7.7

① Highest sales volume tested combination required by D.O.E. test procedures.

[ ] Designates Metric Conversions

# Performance Data ARI Standard Conditions (cont.)

Note: Only these combinations of indoor/outdoor units are approved and any other combinations should not be used.

Model Numbers		ARI Cooling Performance							ARI Htg. Performance (70°F [21.0°C] Indoor)				
		80°F [126.5°C] DB/67°F [119.5°C] WB Indoor Air 95°F[135.0°C] DB Outdoor Air							Outdoor Air 47°F DB/43°F WB [8.5°C/6.0°C] DOE High Temp.		Outdoor Air 17°F DB/15°F WB [-8.5°C/-9.5°C] DOE Low Temp.		DOE Region IV HSPF
Outdoor Unit 14PJL	Indoor Coil and/or Air Handler	Total Capacity BTU/H [kW]	Net Sens. BTU/H [kW]	Net Latent BTU/H [kW]	EER	SEER	Snd. Rate dB	Indoor CFM [L/s]	BTU/H [kW]	COP	BTU/H [kW]	COP	
Rev. 1/10/2008	RHLL-HM3617 (RCSL-H*3617A*) ①	35,000 [10.3]	25,950 [7.6]	9,050 [2.7]	12.00	14.00	75	1,200 [566]	34,000 [10.0]	3.58	22,000 [6.4]	2.46	8.5
	RCFL-H*3617A*	33,800 [9.9]	24,750 [7.3]	9,050 [2.7]	10.95	13.00	75	1,075 [507]	34,400 [10.1]	3.46	22,400 [6.6]	2.40	7.7
	RCFL-H*3621A*	33,800 [9.9]	24,750 [7.3]	9,050 [2.7]	10.95	13.00	75	1,075 [507]	34,400 [10.1]	3.46	22,400 [6.6]	2.40	7.7
	RBHP-21 (RCHL-36A1)	35,400 [10.4]	25,650 [7.5]	9,750 [2.9]	11.75	13.50	75	1,175 [554]	36,000 [10.5]	3.50	23,400 [6.9]	2.36	7.7
	17AHLL36HM (RCSL-H*3617A*)	35,000 [10.3]	25,950 [7.6]	9,050 [2.7]	12.00	14.00	75	1,200 [566]	34,000 [10.0]	3.58	22,000 [6.4]	2.46	8.5
	17AHSL36HM (RCSL-H*3617A*)	34,400 [10.1]	25,500 [7.5]	8,900 [2.6]	11.15	13.00	75	1,100 [519]	34,600 [10.1]	3.44	22,600 [6.6]	2.38	7.7
	RHSL-HM3617 (RCSL-H*3617A*)	34,400 [10.1]	25,350 [7.4]	9,050 [2.7]	11.10	13.00	75	1,200 [566]	34,600 [10.1]	3.44	22,600 [6.6]	2.40	7.7
	RHSL-HM3621 (RCSL-H*3621A*)	34,400 [10.1]	25,350 [7.4]	9,050 [2.7]	11.10	13.00	75	1,200 [566]	34,600 [10.1]	3.44	22,600 [6.6]	2.40	7.7
42	RHLL-HM4821 (RCSL-H*4821A*) ①	42,000 [12.3]	31,350 [9.2]	10,650 [3.1]	12.00	14.00	77	1,400 [661]	41,000 [12.0]	3.74	27,000 [7.9]	2.66	8.5
	RCFL-H*4821A*	41,000 [12.0]	30,350 [8.9]	10,650 [3.1]	10.90	13.00	77	1,400 [661]	41,500 [12.2]	3.56	27,800 [8.1]	2.54	7.7
	RCFL-H*4824A*	41,000 [12.0]	30,350 [8.9]	10,650 [3.1]	10.90	13.00	77	1,400 [661]	41,500 [12.2]	3.56	27,800 [8.1]	2.54	7.7
	RBHP-24 (RCHL-48A1)	40,000 [11.7]	28,250 [8.3]	11,750 [3.4]	11.80	14.00	77	1,400 [661]	41,500 [12.2]	3.60	28,000 [8.2]	2.66	8.5
	21AHLL48HM (RCSL-H*4821A*)	42,000 [12.3]	31,350 [9.2]	10,650 [3.1]	12.00	14.00	77	1,400 [661]	41,000 [12.0]	3.74	27,000 [7.9]	2.66	8.5
	21AHSL42HM (RCSL-H*4821A*)	41,000 [12.0]	30,350 [8.9]	10,650 [3.1]	11.05	13.00	77	1,400 [661]	41,500 [12.2]	3.60	27,600 [8.1]	2.54	7.7
	RHSL-HM4221 (RCSL-H*4821A*)	41,000 [12.0]	30,350 [8.9]	10,650 [3.1]	11.05	13.00	77	1,400 [661]	41,500 [12.2]	3.60	27,600 [8.1]	2.54	7.7
48	RHLL-HM4821 (RCSL-H*4821A*) ①	47,500 [13.9]	34,950 [10.2]	12,550 [3.7]	12.00	14.00	77	1,600 [755]	45,500 [13.3]	3.72	29,800 [8.7]	2.68	8.5
	RCFL-H*4821A*	46,000 [13.5]	33,450 [9.8]	12,550 [3.7]	10.85	13.00	77	1,475 [696]	46,000 [13.5]	3.58	30,400 [8.9]	2.58	7.7
	RCFL-H*4824A*	46,000 [13.5]	33,450 [9.8]	12,550 [3.7]	10.85	13.00	77	1,475 [696]	46,000 [13.5]	3.58	30,400 [8.9]	2.58	7.7
	21AHLL48HM (RCSL-H*4821A*)	47,500 [13.9]	34,950 [10.2]	12,550 [3.7]	12.00	14.00	77	1,600 [755]	45,500 [13.3]	3.72	29,800 [8.7]	2.68	8.5
	21AHSL48HM (RCSL-H*4821A*)	46,500 [13.6]	33,950 [9.9]	12,550 [3.7]	10.90	13.00	77	1,600 [755]	46,000 [13.5]	3.54	30,600 [9.0]	2.60	7.7
	RHSL-HM4821 (RCSL-H*4821A*)	46,500 [13.6]	33,950 [9.9]	12,550 [3.7]	10.90	13.00	77	1,600 [755]	46,000 [13.5]	3.54	30,600 [9.0]	2.60	7.7
	24AHLL48HM (RCSL-H*4824A*)	48,000 [14.1]	36,500 [10.7]	11,500 [3.4]	12.00	14.00	77	1,625 [767]	45,500 [13.3]	3.74	29,800 [8.7]	2.68	8.5
	24AHSL48HM (RCSL-H*4824A*)	46,500 [13.6]	33,950 [9.9]	12,550 [3.7]	10.90	13.00	77	1,600 [755]	46,000 [13.5]	3.54	30,600 [9.0]	2.60	7.7
	RHLL-HM4824 (RCSL-H*4824A*)	48,000 [14.1]	36,500 [10.7]	11,500 [3.4]	12.00	14.00	77	1,625 [767]	45,500 [13.3]	3.74	29,800 [8.7]	2.68	8.5
		RHSL-HM4824 (RCSL-H*4824A*)	46,500 [13.6]	33,950 [9.9]	12,550 [3.7]	10.90	13.00	77	1,600 [755]	46,000 [13.5]	3.54	30,600 [9.0]	2.60
60	RHLL-HM6024 (RCSL-H*6024A*) ①	59,000 [17.3]	43,800 [12.8]	15,200 [4.5]	12.00	14.00	77	1,850 [873]	58,500 [17.1]	3.76	38,000 [11.1]	2.66	8.5
	RCFL-H*6024A*	57,500 [16.8]	42,300 [12.4]	15,200 [4.5]	11.30	13.00	77	1,675 [790]	57,500 [16.8]	3.96	36,800 [10.8]	2.80	7.7
	24AHLL60HM (RCSL-H*6024A*)	59,000 [17.3]	43,800 [12.8]	15,200 [4.5]	12.00	14.00	77	1,850 [873]	58,500 [17.1]	3.76	38,000 [11.1]	2.66	8.5
	RHSL-HM6024 (RCSL-H*6024A*)	58,500 [17.1]	44,150 [12.9]	14,350 [4.2]	11.05	13.00	77	1,750 [826]	59,000 [17.3]	3.64	38,500 [11.3]	2.58	7.7

① Highest sales volume tested combination required by D.O.E. test procedures.

[ ] Designates Metric Conversions

# Electrical and Physical Data

Model Number 14PJL	ELECTRICAL							PHYSICAL					
	Phase Frequency (Hz) Voltage (Volts)	Compressor		Fan Motor Full Load Amperes (FLA)	Minimum Circuit Ampacity Amperes	Fuse or HACR Circuit Breaker		Outdoor Coil			Refrig. Per Circuit Oz. [g]	Weight	
		Rated Load Amperes (RLA)	Locked Rotor Amperes (LRA)			Minimum Amperes	Maximum Amperes	Face Area Sq. Ft. [m <sup>2</sup> ]	No. Rows	CFM [L/s]		Net Lbs. [kg]	Shipping Lbs. [kg]
Rev. 1/10/2008													
18	1-60-208/230	9/9	48	0.6	12/12	15/15	20/20	11.06 [1.03]	1	1700 [802]	91 [2580]	144 [65.3]	152 [68.9]
24	1-60-208/230	12.8/12.8	58.3	0.6	17/17	20/20	25/25	11.06 [1.03]	1	2370 [1118]	91 [2580]	130 [59]	138 [62.6]
30	1-60-208/230	14.1/14.1	73	0.8	19/19	25/25	30/30	13.72 [1.27]	1	2800 [1321]	101 [2863]	180 [81.6]	190 [86.2]
36	1-60-208/230	17/17	96.7	1.2	23/23	30/30	35/35	16.39 [1.52]	1	3575 [1687]	109 [3090]	215 [97.5]	227 [103]
42	1-60-208/230	17.9/17.9	112	1.2	24/24	30/30	40/40	21.85 [2.03]	1	3575 [1687]	150 [4252]	202 [91.6]	214 [97.1]
48	1-60-208/230	21.8/21.8	117	1.2	29/29	35/35	50/50	21.85 [2.03]	1	3575 [1687]	141 [3997]	205 [93]	217 [98.4]
60	1-60-208/230	26.4/26.4	150	1.2	35/35	45/45	60/60	21.85 [2.03]	2	3360 [1586]	259 [7343]	277 [125]	289 [131.1]

NOTES:  
 ① 20 Fins per inch.  
 ② Factory charged for 15 ft. line set.

[ ] Designates Metric Conversions

**BEFORE PURCHASING THIS APPLIANCE, READ IMPORTANT ENERGY COST AND EFFICIENCY INFORMATION AVAILABLE FROM YOUR RETAILER.**

## GENERAL TERMS OF LIMITED WARRANTY

Rheem will furnish a replacement for any part of this product which fails in normal use and service within the applicable periods stated, in accordance with the terms of the limited warranty.

**For Complete Details of the Limited Warranty, Including Applicable Terms and Conditions, See the Product Warranty Card.**

Condenser Coil leaks caused by  
 factory defects .....Five (5) Years  
 Conditional Compressor\* .....Ten (10) Years  
 Any Other Part.....Five (5) Years

\*See Product Warranty Card for Details.

# Unit Dimensions

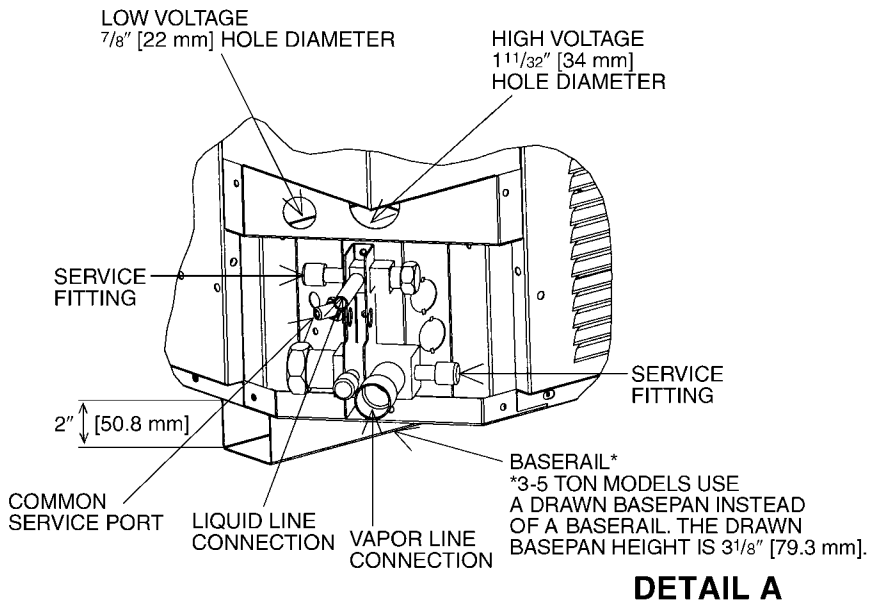
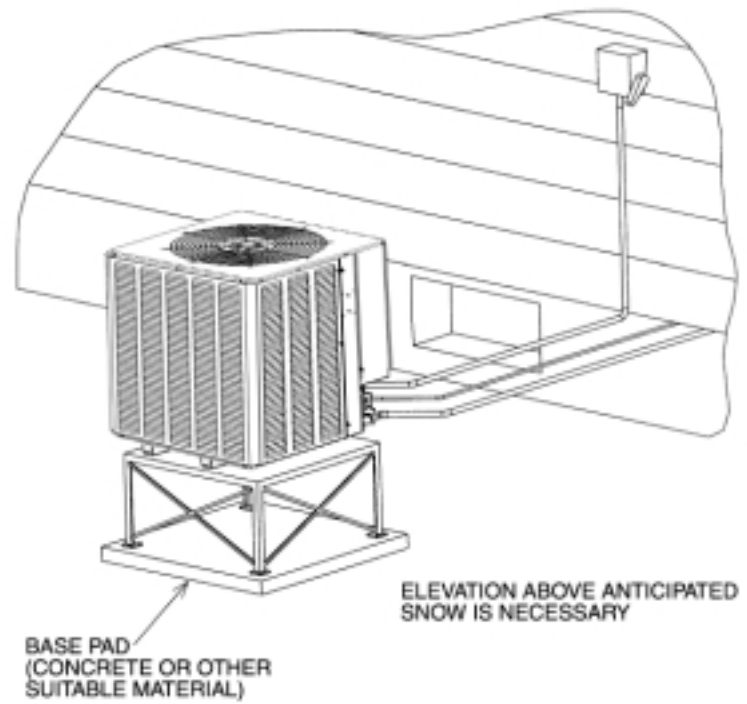
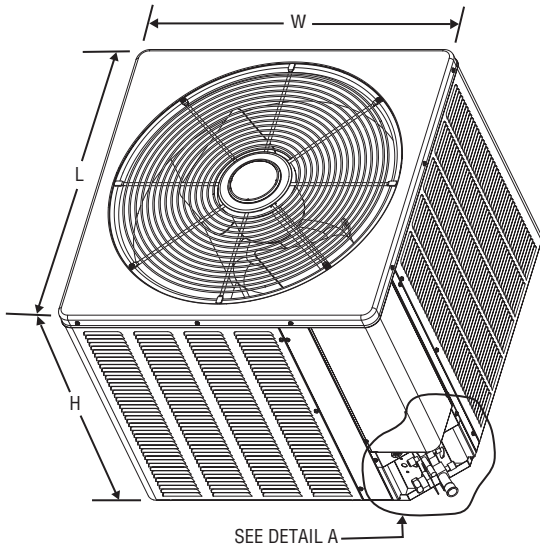

Model Number 14PJL	Height "H" (Inches) [mm]	Length "L" (Inches) [mm]	Width "W" (Inches) [mm]
18, 24	26 <sup>1</sup> / <sub>4</sub> [666.75]	23 <sup>5</sup> / <sub>8</sub> [600.07]	23 <sup>5</sup> / <sub>8</sub> [600.07]
30	26 <sup>1</sup> / <sub>4</sub> [666.75]	27 <sup>5</sup> / <sub>8</sub> [701.67]	27 <sup>5</sup> / <sub>8</sub> [701.67]
36	27 <sup>3</sup> / <sub>8</sub> [695.32]	31 <sup>5</sup> / <sub>8</sub> [803.27]	31 <sup>5</sup> / <sub>8</sub> [803.27]
42, 48, 60	35 <sup>3</sup> / <sub>8</sub> [898.52]	31 <sup>5</sup> / <sub>8</sub> [803.27]	31 <sup>5</sup> / <sub>8</sub> [803.27]

[ ] Designates Metric Conversions

# Heat Pump Refrigerant Line Size Information

System Capacity	Line Size Connection Size (Inch I.D.) [mm]	Line Size (Inch O.D.) [mm]	Liquid Line Sizing (R410A)					
			Outdoor Unit Above or Below Indoor Coil (Heat Pumps Only)					
			Total Equivalent Length—Feet [m]					
			25 [7.62]	50 [15.24]	75 [22.86]	100 [30.48]	125 [38.10]	150 [45.72]
Maximum Vertical Separation—Feet [m]								
1½ Ton	3/8" [9.53]	1/4 [6.35]	25 [7.62]	40 [12.19]	25 [7.62]	9 [2.74]	N/A	N/A
		5/16 [7.94]	25 [7.62]	50 [15.24]	62 [18.90]	58 [17.68]	53 [16.15]	49 [14.94]
		3/8* [9.53]	25 [7.62]	50 [15.24]	75 [22.86]	72 [21.95]	70 [21.34]	68 [20.73]
2 Ton	3/8" [9.53]	1/4 [6.35]	23 [7.01]	N/A	N/A	N/A	N/A	N/A
		5/16 [7.94]	25 [7.62]	36 [10.97]	29 [8.84]	23 [7.01]	16 [4.88]	9 [2.74]
		3/8* [9.53]	25 [7.62]	50 [15.24]	72 [21.95]	70 [21.34]	68 [20.73]	65 [19.81]
2½ Ton	3/8" [9.53]	1/4 [6.35]	25 [7.62]	N/A	N/A	N/A	N/A	N/A
		5/16 [7.94]	25 [7.62]	49 [14.94]	38 [11.58]	27 [8.23]	17 [5.18]	6 [1.83]
		3/8* [9.53]	25 [7.62]	50 [15.24]	68 [20.73]	65 [19.81]	62 [18.90]	58 [17.68]
3 Ton	3/8" [9.53]	5/16 [7.94]	25 [7.62]	50 [15.24]	37 [11.28]	22 [6.71]	7 [2.13]	N/A
		3/8* [9.53]	25 [7.62]	50 [15.24]	68 [20.73]	63 [19.20]	58 [17.68]	53 [16.15]
3½ Ton	3/8" [9.53]	5/16 [7.94]	25 [7.62]	23 [7.01]	4 [1.22]	N/A	N/A	N/A
		3/8* [9.53]	25 [7.62]	50 [15.24]	43 [13.11]	36 [10.97]	30 [9.14]	24 [7.32]
4 Ton	3/8" [9.53]	3/8* [9.53]	25 [7.62]	46 [14.02]	38 [11.58]	30 [9.14]	22 [6.71]	15 [4.57]
		1/2 [12.7]	25 [7.62]	50 [15.24]	56 [17.07]	55 [16.76]	53 [16.15]	52 [15.85]
5 Ton	3/8" [9.53]	3/8* [9.53]	25 [7.62]	50 [15.24]	56 [17.07]	44 [13.41]	32 [9.75]	20 [6.10]
		1/2 [12.7]	25 [7.62]	50 [15.24]	75 [22.86]	81 [24.69]	79 [24.08]	76 [23.16]

NOTES:  
 \*Standard line size  
 N/A = Application not recommended.

Suction Line Length/Size versus Capacity Multiplier (R-410A)								
Unit Size	1½ Ton	2 Ton	2½ Ton	3 Ton	3½ Ton	4 Ton	5 Ton	
Suction Line Connection Size	3/4" [19.05] I.D.			7/8" [22.23] I.D.				
Suction Line Run—Feet [m]	5/8" [15.88 mm] O.D. Opt. 3/4" [19.05 mm] O.D. Std.*	5/8" [15.88 mm] O.D. Opt. 3/4" [19.05 mm] O.D. Std.* 7/8" [22.23 mm] O.D. Opt.	3/4" [19.05 mm] O.D. Opt. 7/8" [22.23 mm] O.D. Std.*	7/8" [22.23 mm] O.D. Opt. 1 1/8" [28.58 mm] O.D. Std.*				
25' [7.62]	Optional: 1.00 Standard: 1.00 Optional: —	Optional: 1.00 Standard: 1.00 Optional: —	Optional: 1.00 Standard: 1.00 Optional: 1.00	Optional: 1.00 Standard: 1.00 Optional: —	Optional: 1.00 Standard: 1.00 Optional: —	Optional: 1.00 Standard: 1.00 Optional: —	Optional: 1.00 Standard: 1.00 Optional: —	
50' [15.24]	Optional: 0.98 Standard: 0.99 Optional: —	Optional: 0.98 Standard: 0.99 Optional: —	Optional: 0.96 Standard: 0.98 Optional: 0.99	Optional: 0.98 Standard: 0.99 Optional: —	Optional: 0.99 Standard: 0.99 Optional: —	Optional: 0.99 Standard: 0.99 Optional: —	Optional: 0.99 Standard: 0.99 Optional: —	
100' [30.48]	Optional: 0.95 Standard: 0.96 Optional: —	Optional: 0.95 Standard: 0.96 Optional: —	Optional: 0.94 Standard: 0.96 Optional: 0.97	Optional: 0.96 Standard: 0.97 Optional: —	Optional: 0.96 Standard: 0.98 Optional: —	Optional: 0.96 Standard: 0.98 Optional: —	Optional: 0.97 Standard: 0.98 Optional: —	
150' [45.72]	Optional: 0.92 Standard: 0.93 Optional: —	Optional: 0.92 Standard: 0.94 Optional: —	Optional: 0.91 Standard: 0.93 Optional: 0.95	Optional: 0.94 Standard: 0.95 Optional: —	Optional: 0.94 Standard: 0.96 Optional: —	Optional: 0.95 Standard: 0.96 Optional: —	Optional: 0.94 Standard: 0.97 Optional: —	

NOTES:  
 \*Standard line size  
 N/A = Using suction line larger than shown in chart will result in poor oil return and is not recommended. [ ] Designates Metric Conversions

# NOTES

**Before proceeding with installation, refer to installation instructions packaged with each model, as well as complying with all Federal, State, Provincial, and Local codes, regulations, and practices.**

**Rheem Heating,  
Cooling and  
Water Heating**

P.O. Box 17010, Fort Smith, AR 72917



*"In keeping with its policy of continuous progress and product improvement, Rheem reserves the right to make changes without notice."*