



Select series



UPFLOW/ HORIZONTAL GAS FURNACES

Features

- 80% residential Gas Furnace CSA certified
- 3 way multi poise design UF / HZ
- 7 Segment LED all units
- Direct spark ignition —for reliability and longevity
- Heat exchanger is removable for improved serviceability. Aluminized steel construction provides maximum corrosion resistance and thermal fatigue reliability.
- Solid doors provide quiet operation
- Low profile 34" cabinet ideal for space constrained installations
- Blower shelf design – serviceable in all furnace orientations
- Hemmed edges on cabinets and doors
- 1/4 turn door knobs for tool less access
- Integrated Controls board features dip switches for easy system set up
- QR code for quick access to product information from your smart phone or tablet

†A.F.U.E. (Annual Fuel Utilization Efficiency) calculated in accordance with Department of Energy test procedures.

W801S (UPFLOW/ HORIZONTAL) SERIES

Models with Input Rates
from 50 to 150 kBTU
[15 to 44 kW]

(80% A.F.U.E.†)



TABLE OF CONTENTS

Standard & Optional Equipment	3
Model Features/Physical Data & Specifications.....	4
Model Number Identification	5
Dimensional Data	6-7
Blower Performance Data.....	8
Accessories.....	9
Limited Warranty	10

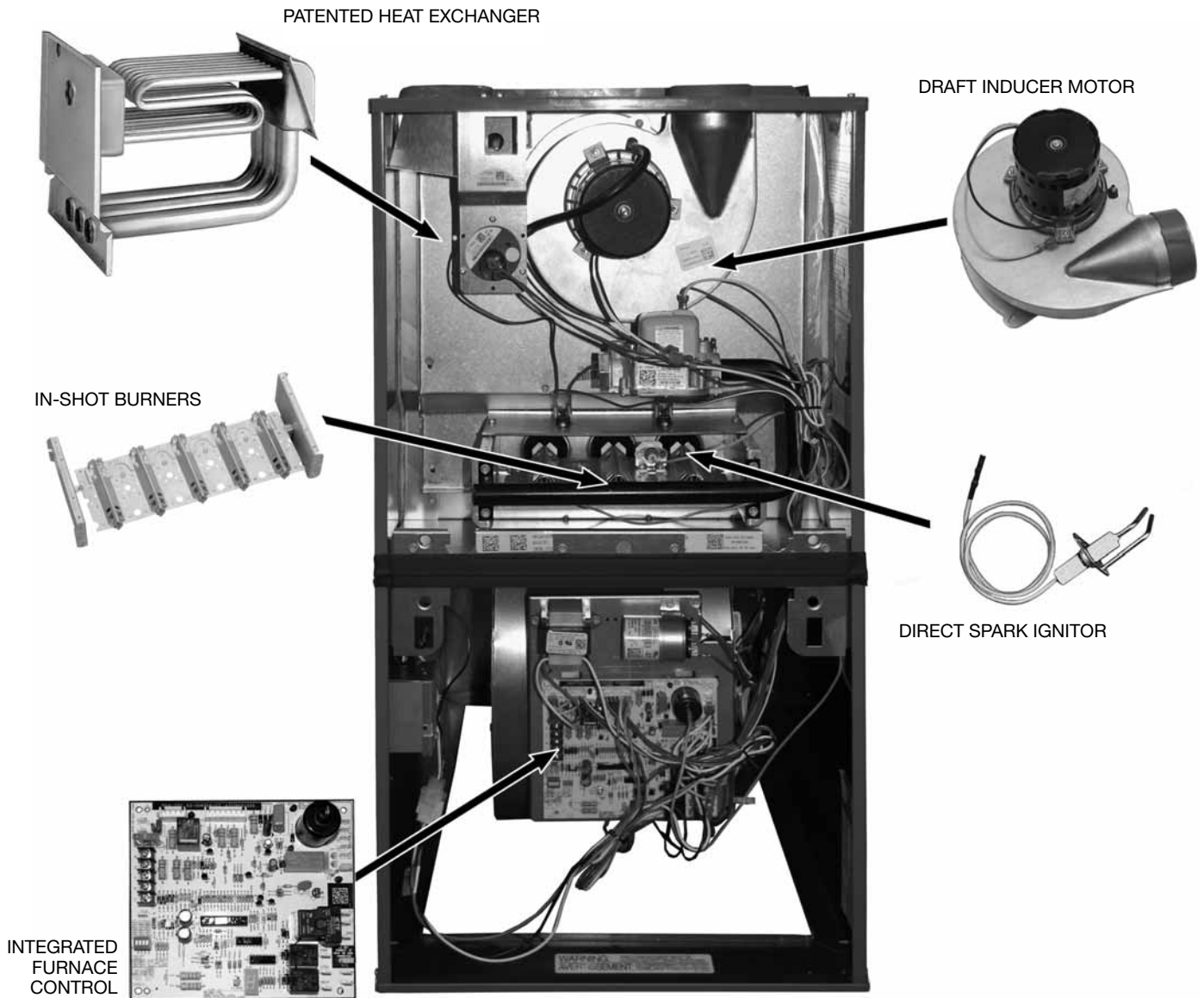

STANDARD EQUIPMENT

Completely assembled and wired; induced draft; pressure switch; redundant main gas control; blower compartment door safety switch; solid state time on/time off blower control; limit control; manual shut-off valve, pressure regulator for natural and L.P. (propane) gas; transformer; direct drive multi-speed blower motor. Furnaces are equipped with cooling/heating relay and transformer (40VA) ready for air conditioning applications. (Please note: a thermostat is not included as standard equipment.) Flame sensor diagnostics.

OPTIONAL EQUIPMENT

Side and bottom filter frame assembly. Return air cabinet for all sizes.
NOTE: Furnace is not listed for use with fuels other than natural or L.P. (propane) gas.

The complete terms of limited and other warranties are available at our sales office, or through local installer.

All models can be converted by a qualified WeatherKing distributor or local service dealer to use L.P. (propane) gas without changing burners. Factory approved kits must be used to convert from natural to L.P. (propane) gas and may be ordered as optional accessories from a WeatherKing parts distributor.

For L.P. (propane) operation, refer to Conversion Kit Index Form.

NOTE: For natural and L.P. (propane) gas models, direct spark ignition is 100% safety lockout type.

WARNING
THIS FURNACE IS NOT APPROVED
OR RECOMMENDED
FOR USE IN MOBILE HOMES

Model Features

- 80% residential Gas Furnace CSA certified
- 3 way multi poise design UF / HZ
- 7 Segment LED all units
- Direct spark ignition for reliability and longevity
- Heat exchanger is removable for improved serviceability. Aluminized steel construction provides maximum corrosion resistance and thermal fatigue reliability.
- Solid doors provide quiet operation
- Low profile 34" cabinet ideal for space constrained installations
- Blower shelf design serviceable in all furnace orientations
- Hemmed edges on cabinets and doors
- 1/4 turn door knobs for tool less access
- Integrated Controls board features dip switches for easy system set up
- QR code for quick access to product information from your smart phone or tablet

Physical Data and Specifications

MODEL NUMBERS W801S SERIES	W801SA050314M*A	W801SA075317M*A	W801SA075417M*A	W801SA100417M*A	W801SA100521M*A	W801SA125524M*A	W801SA150524M*A
Input-BTU/Hr ②	50,000	75,000	75,000	100,000	100,000	125,000	150,000
Heating Capacity BTU/Hr ①	40,000	60,000	60,000	80,000	80,000	100,000	120,000
Heat Ext. Static Pressure	.18	.20	.20	.28	.28	.28	.28
Blower (D x W)	11 x 6	11 x 7	11 x 7	11 x 7	11 x 10	11 x 10	11 x 10
Motor H.P.–Speed–Type	1/3-4-PSC	1/2-4-PSC	1/2-4-PSC	1/2-4-PSC	1/2-4-PSC	3/4-4-PSC	3/4-4-PSC
Min Circuit Ampacity	9	10	9	11	9	12	13
Min. Overload Protection	15	15	15	15	15	15	15
Max. Overload Protection	15	15	15	15	15	15	20
Motor Full Load Amps	5.7	6.7	7.8	7.8	7.5	8.4	9.3
Heating Speed	Med-Low	Med-High	Med-High	Med-High	Med-Low	Med-High	Med-High
Cooling Speed	High	Med-High	High	Med-High	High	High	High
Cooling CFM @ .70" W.C. E.S.P.	1164	1198	1657	1292	1807	1742	1916
Max. E.S.P. (In. W.C.)	0.8	0.8	0.8	0.8	0.8	0.8	0.8
Temperature Rise Range °F	25-55	25-55	25-55	35-65	35-65	35-65	45-75
Max. Outlet Air Temp. °F	155	155	155	165	180	165	190
Approx. Shipping Weight (Lbs.)	110	110	125	110	140	150	160
AFUE ①	80.0%	80%	80.0%	80.0%	80.0%	80.0%	80.0%

NOTES: All models are 115V, 60HZ, 1 Ph. Gas connection size for all models is 1/2" [12 mm] N.P.T.

① In accordance with D.O.E. test procedures.

② See Conversion Kit Index Form for high altitude derate.

* S = Standard, X = Low Nox

[] Designates Metric Conversions

Model Number Identification

<u>W</u>	<u>80</u>	<u>1</u>	<u>S</u>	<u>A</u>	<u>075</u>	<u>4</u>	<u>17</u>	<u>M</u>	<u>S</u>	<u>A</u>
W	80 =	1 = Single Stage	S = PSC	Design Series	Input	3 = Up to	Cabinet	M = Multi	X = Low NO _x	Revision-
E	80% AFUE		Standard	A = 1st Design	<u>BTU/HR [kW]</u>	3 Ton	Width		S = Standard	Marketing
A					050 = 50,000 [15]	4 = Up to	14 = 14"			(A – First Time
T					075 = 75,000 [22]	4 Ton	17 = 17.5"			Release)
H					100 = 100,000 [29]	5 = Up to	21 = 21"			
E					125 = 125,000 [37]	5 Ton	24 = 24.5"			
R					150 = 150,000 [44]					
K										
I										
N										
G										

[] Designates Metric Conversions

Upflow Application

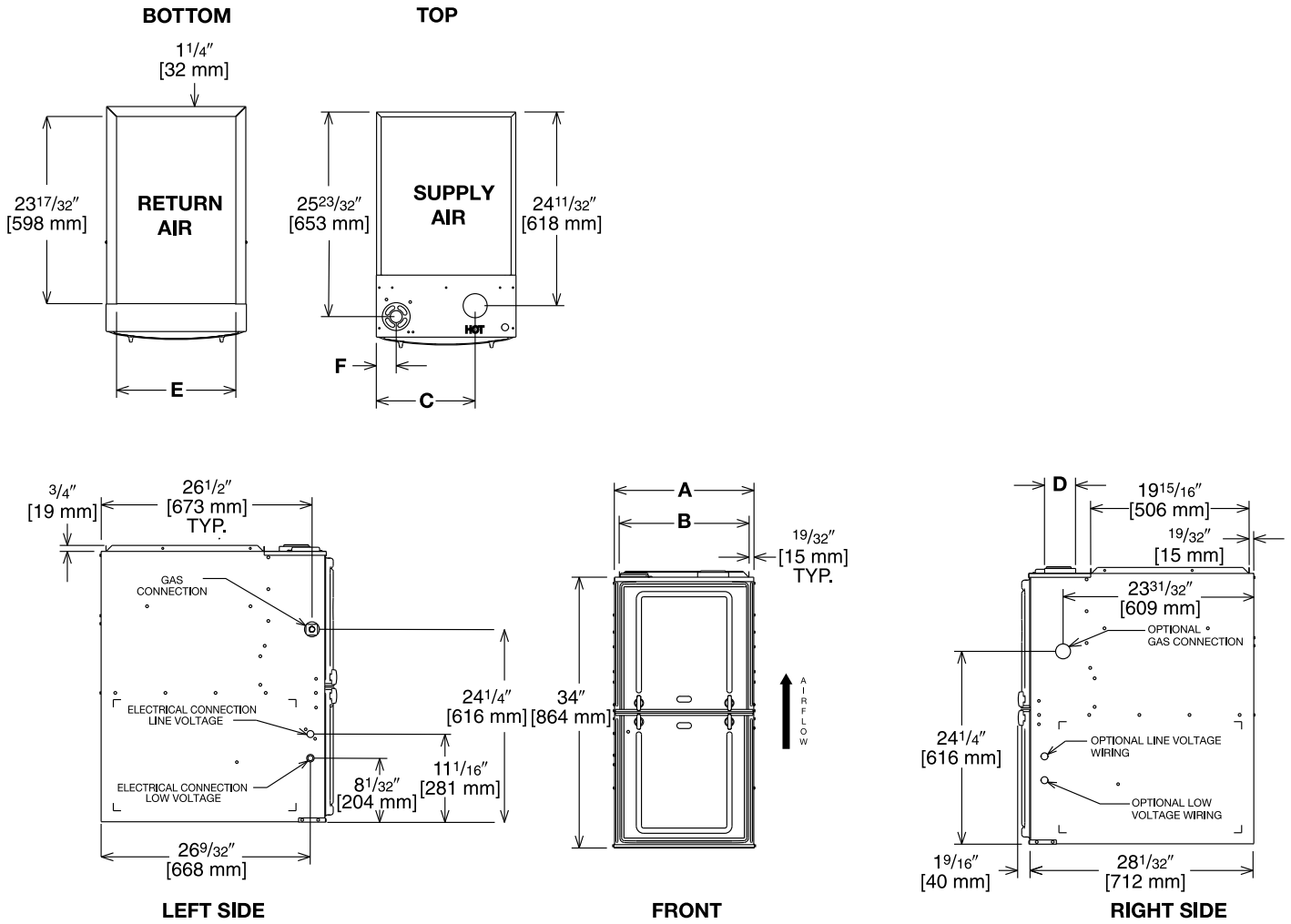

Illustration
ST-A1220-04-00
FIGURE 1

Dimensional Data: Upflow Model

MODEL W801S-	A	B	C	D	E	F	REDUCED CLEARANCE (IN.) [mm]						SHIP WGTS. (LBS.) [kg]
							LEFT SIDE	RIGHT SIDE	BACK	TOP	FRONT	VENT	
050	14 [356]	12 ²⁷ / ₃₂ [326]	10 ⁵ / ₈ [270]	①	11 1/2 [292]	1 7/8 [48]	0	4 [102] ②	0	1 [25]	3 [76]	6 [152] ③	110 [50]
075	17 1/2 [445]	16 11/32 [415]	12 ³ / ₈ [314]	①	15 [381]	2 1/2 [64]	0	3 [76] ②	0	1 [25]	3 [76]	6 [152] ③	125 [57]
100	21 [533]	19 ²⁷ / ₃₂ [504]	14 1/8 [359]	①	18 1/2 [470]	2 1/2 [64]	0	0	0	1 [25]	3 [76]	6 [152] ③	140 [64]
125	24 1/2 [622]	23 11/32 [593]	15 ⁷ / ₈ [403]	①	22 [559]	2 1/2 [64]	0	0	0	1 [25]	3 [76]	6 [152] ③	150 [68]
150	24 1/2 [622]	23 11/32 [593]	15 ⁷ / ₈ [403]	①	22 [559]	2 1/2 [64]	0	0	0	1 [25]	3 [76]	6 [152] ③	160 [73]

NOTES: ① May require a 3" [76 mm] to 4" [102 mm] or 3" [76 mm] to 5" [127 mm] adapter. 4" adapter included with (-)801P units.

② May be 0" [0 mm] with type B vent.

③ May be 1" [25 mm] with type B vent.

Furnaces must be vented in accordance with the National Fuel Gas Code, ANSI Z223.1 and in accordance with local codes.

[] Designates Metric Conversions

Horizontal Application

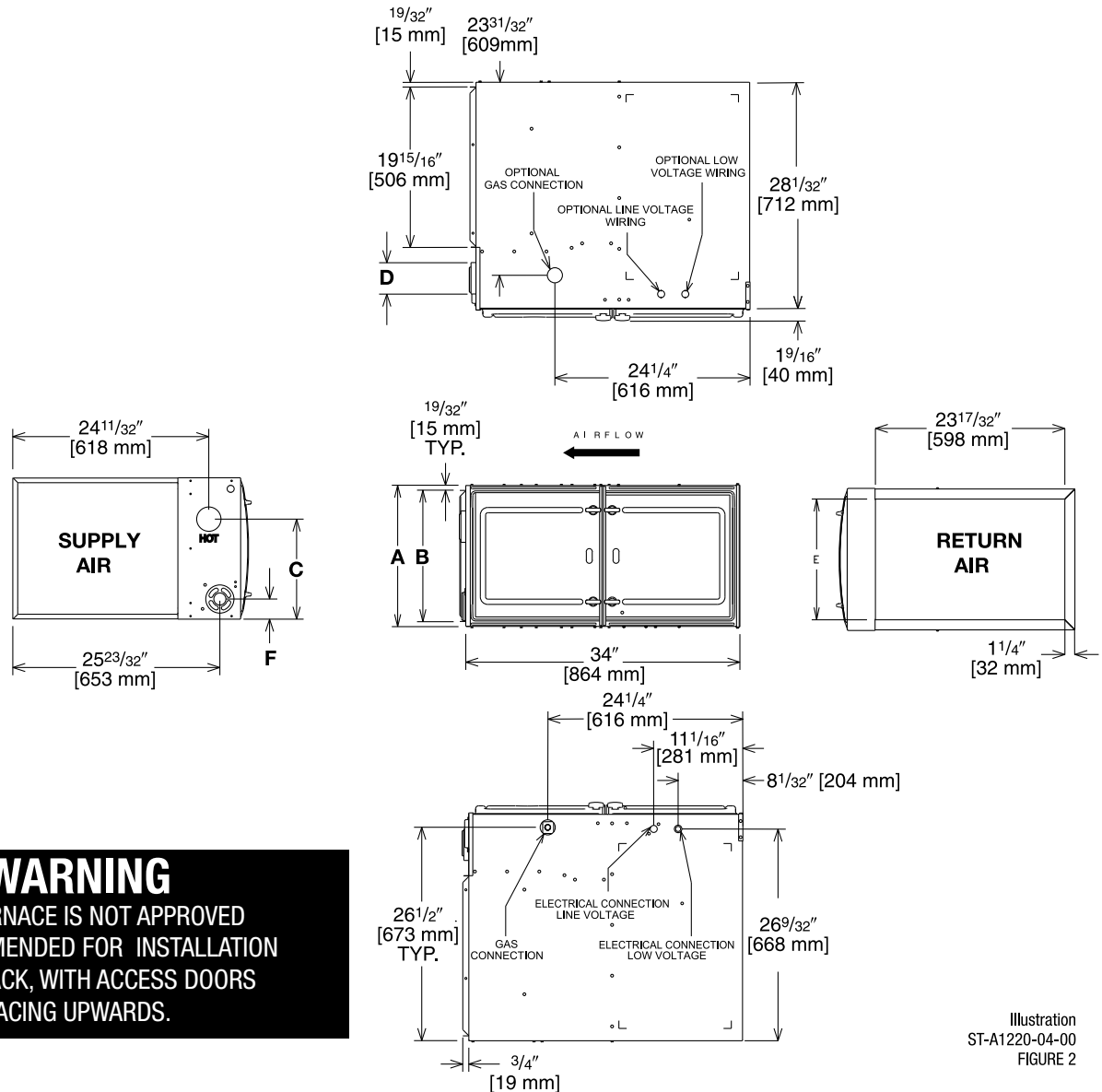

Illustration
ST-A1220-04-00
FIGURE 2

WARNING
THIS FURNACE IS NOT APPROVED
OR RECOMMENDED FOR INSTALLATION
ON ITS BACK, WITH ACCESS DOORS
FACING UPWARDS.

Dimensional Data: Horizontal Model

MODEL W801S-	A	B	C	D	E	F	REDUCED CLEARANCE (IN.) [mm]						SHIP WGTS. (LBS.) [kg]
							LEFT SIDE	RIGHT SIDE	BACK	TOP	FRONT	VENT	
050	14 [356]	12 ²⁷ / ₃₂ [326]	10 ⁵ / ₈ [270]	①	11 1/2 [292]	1 7/8 [48]	0	4 [102] ②	0	1 [25]	3 [76]	6 [152] ③	110 [50]
075	17 1/2 [445]	16 ¹¹ / ₃₂ [415]	12 ³ / ₈ [314]	①	15 [381]	2 1/2 [64]	0	3 [76] ②	0	1 [25]	3 [76]	6 [152] ③	125 [57]
100	21 [533]	19 ²⁷ / ₃₂ [504]	14 ¹ / ₈ [359]	①	18 1/2 [470]	2 1/2 [64]	0	0	0	1 [25]	3 [76]	6 [152] ③	140 [64]
125	24 1/2 [622]	23 ¹¹ / ₃₂ [593]	15 ⁷ / ₈ [403]	①	22 [559]	2 1/2 [64]	0	0	0	1 [25]	3 [76]	6 [152] ③	150 [68]
150	24 1/2 [622]	23 ¹¹ / ₃₂ [593]	15 ⁷ / ₈ [403]	①	22 [559]	2 1/2 [64]	0	0	0	1 [25]	3 [76]	6 [152] ③	160 [73]

NOTES: ① May require a 3" [76 mm] to 4" [102 mm] or 3" [76 mm] to 5" [127 mm] adapter. 4" adapter included with (-)801P units.

② May be 0" [0 mm] with type B vent.

③ May be 1" [25 mm] with type B vent.

Furnaces must be vented in accordance with the National Fuel Gas Code, ANSI Z223.1 and in accordance with local codes.

[] Designates Metric Conversions

Blower Performance Data

MODEL	MOTOR H.P. [W] BLOWER SIZE IN [mm]	SPEED TAP	CFM [L/s] AIR DELIVERY EXTERNAL STATIC PRESSURE INCHES WATER COLUMN [kPa]							
			0.1 [.02]	0.2 [.05]	0.3 [.07]	0.4 [.10]	0.5 [.12]	0.6 [.15]	0.7 [.17]	0.8 [.19]
(-)801SA050314M*A	1/3 [249] 11 x 6 [279 x 152]	Low	823	803	787	732	718	691	651	593
		Med. Lo	1030	1018	1006	976	929	897	850	808
		Med. Hi	1129	1132	1112	1087	1054	1028	971	919
		High	1361	1353	1331	1297	1264	1232	1164	1117
(-)801SA075317M*A	1/2 [373] 11 x 7 [279 x 178]	Low	1008	977	935	893	854	823	777	735
		Med. Lo	1215	1181	1133	1098	1065	1023	975	937
		Med. Hi	1421	1408	1372	1326	1299	1247	1198	1152
		High	1668	1648	1633	1580	1545	1481	1442	1373
(-)801SA075417M*A	1/2 [373] 11 x 7 [279 x 178]	Low	1229	1200	1181	1155	1120	1078	1013	970
		Med. Lo	1308	1267	1266	1233	1204	1176	1113	1062
		Med. Hi	1553	1542	1516	1491	1451	1417	1358	1306
		High	1969	1924	1893	1840	1803	1728	1657	1570
(-)801SA100417M*A	1/2 [373] 11 x 7 [279 x 178]	Low	1211	1183	1148	1116	1077	1040	984	953
		Med. Lo	1305	1261	1225	1185	1157	1113	1068	1012
		Med. Hi	1520	1498	1464	1427	1387	1340	1292	1226
		High	1874	1810	1767	1686	1678	1650	1582	1497
(-)801SA100521M*A	1/2 [373] 11 x 10 [279 x 254]	Low	1209	1182	1131	1112	1051	976	929	867
		Med. Lo	1438	1420	1386	1350	1320	1293	1248	1186
		Med. Hi	1902	1883	1844	1817	1753	1700	1636	1547
		High	2071	2037	2001	1962	1905	1856	1807	1709
(-)801SA125524M*A	3/4 [559] 11 x 10 [279 x 254]	Low	1358	1354	1331	1301	1250	1224	1154	1089
		Med. Lo	1541	1517	1476	1453	1416	1371	1339	1277
		Med. Hi	1799	1774	1746	1712	1691	1629	1554	1495
		High	2015	1989	1929	1902	1862	1815	1742	1665
(-)801SA150524M*A	3/4 [559] 11 x 10 [279 x 254]	Low	1411	1395	1370	1334	1310	1252	1220	1150
		Med. Lo	1606	1579	1569	1537	1499	1468	1407	1346
		Med. Hi	1889	1891	1849	1828	1764	1717	1659	1609
		High	2178	2160	2105	2067	2024	1976	1916	1832

Note: Bold data is factory heating tap.

[] Designates Metric Conversions

SIDE RETURN FILTER RACK: RXGF-CD
BOTTOM RETURN FILTER RACK FOR
UPFLOW APPLICATION: RXGF-CB

FILTER RACK FILTER SIZES* INCHES [mm]		
MODEL	RXGF-CB (UPFLOW/ HORIZONTAL)	RXGF-CD (UPFLOW) SIDE RETURN
W801SA050	12 ¹ / ₄ x 25 [311 x 635]	15 ³ / ₄ x 25 [400 x 635]
W801SA075	15 ³ / ₄ x 25 [400 x 635]	15 ³ / ₄ x 25 [400 x 635]
W801SA100	19 ¹ / ₄ x 25 [489 x 635]	15 ³ / ₄ x 25 [400 x 635]
W801SA125	22 ³ / ₄ x 25 [578 x 635]	15 ³ / ₄ x 25 [400 x 635]
W801SA150	22 ³ / ₄ x 25 [578 x 635]	15 ³ / ₄ x 25 [400 x 635]

4" FLUE ADAPTER: RXGW-C01

INDOOR COIL CASINGS

MODEL NUMBER
RXBC-D14AI
RXBC-D17AI
RXBC-D21AI
RXBC-D21BI
RXBC-D24AI

WARNING: IMPORTANT NOTICE

A SOLID METAL BASE PLATE (SEE TABLE) MUST BE IN PLACE WHEN THE FURNACE IS INSTALLED WITH SIDE AIR RETURN DUCTS. FAILURE TO INSTALL A BASE PLATE COULD CAUSE PRODUCTS OF COMBUSTION TO BE CIRCULATED INTO THE LIVING SPACE AND CREATE POTENTIALLY HAZARDOUS CONDITIONS.

FURNACE WIDTH IN. [mm]	SOLID BOTTOM KIT NO.	BASE PLATE NO.	BASE PLATE SIZE IN. [mm]
14 [356]	RXGB-D14	AE-61874-01	11 ⁵ / ₈ x 23 ⁹ / ₁₆ [295 x 598]
17 ¹ / ₂ [445]	RXGB-D17	AE-61874-02	15 ¹ / ₈ x 23 ⁹ / ₁₆ [384 x 598]
21 [533]	RXGB-D21	AE-61874-03	18 ⁵ / ₈ x 23 ⁹ / ₁₆ [473 x 598]
24 ¹ / ₂ [622]	RXGB-D24	AE-61874-04	25 ⁵ / ₈ x 23 ⁹ / ₁₆ [651 x 598]

FOR HIGH ALTITUDES:

OPTION CODE FOR HIGH ALTITUDE: U.S.

None required for high altitudes.

HIGH ALTITUDE CONVERSION KITS: U.S.

None required for high altitudes.

80+ HIGH ALTITUDE INSTRUCTIONS

CAUTION: Always follow National Fuel Gas Code (NFGC) guidelines when converting for high altitudes.

High altitude option codes are not required for these models. However, the burner orifice size needs to be recalculated and verified at elevations above 2000 ft. See Installation Instructions for more information.

[] Designates Metric Conversions

GENERAL TERMS OF LIMITED WARRANTY*

Rheem Select will furnish a replacement for any part of this product which fails in normal use and service within the applicable period stated, in accordance with the terms of the limited warranty.

***For complete details of the Limited and Conditional Warranties, including applicable terms and conditions, contact your local contractor or the Manufacturer for a copy of the product warranty certificate.**

PartsFive (5) Years
Heat Exchanger.....Ten (10) Years

Before proceeding with installation, refer to installation instructions packaged with each model, as well as complying with all Federal, State, Provincial, and Local codes, regulations, and practices.



Select series

"In keeping with its policy of continuous progress and product improvement, WeatherKing reserves the right to make changes without notice."