

C

C

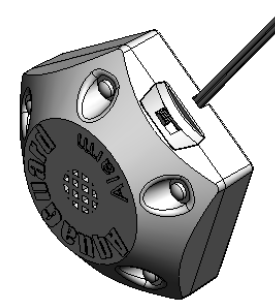
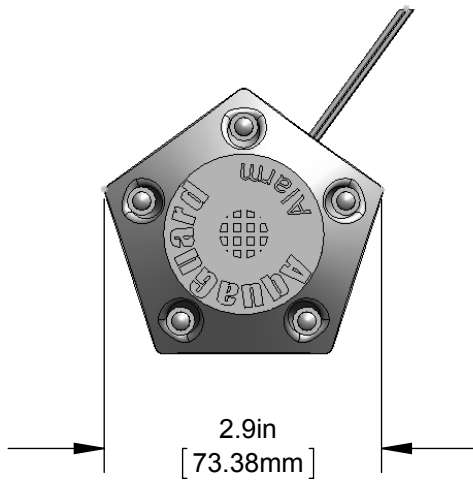

B

B

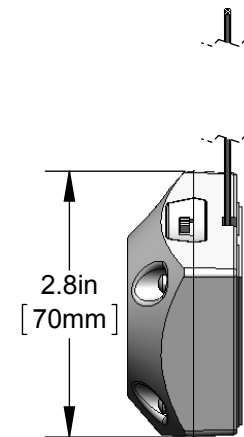
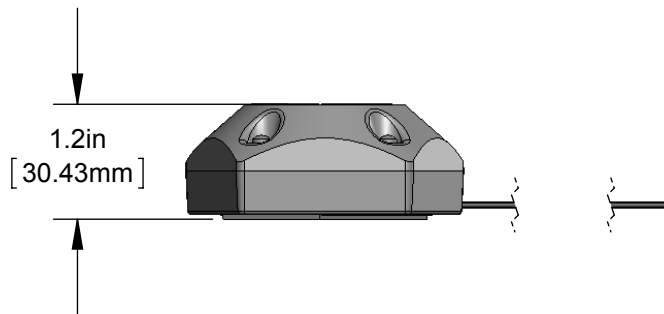

**NOTES:**

THE AG-9100 IS A GENERAL PURPOSE REMOTE ALARM. IT PRODUCES AN AUDIBLE AND VISUAL SIGNAL WHEN ACTIVATED. NO BATTERIES NECESSARY.

THE PERFECT ACCESSORY FOR THE FOLLOWING AQUAGUARD CONDENSATE MANAGEMENT SYSTEMS:

AG-1100+, AG-1200+, AG-1250E, AG-3150E, AG-3175E, AG-3180E, AG-4000 SERIES

UNLESS OTHERWISE SPECIFIED:

DIMENSIONS ARE IN INCHES  
TOLERANCES:  
FRACTIONAL ±.032  
ANGULAR: MACH ± .5° BEND ±2°  
TWO PLACE DECIMAL ± .010  
THREE PLACE DECIMAL ± .005

INTERPRET GEOMETRIC TOLERANCING PER: ANSI Y14.5, 1994

ENGINEERING	NAME	DATE
DRAWN BY ENG.	DS	4/27/10
CHECKED BY ENG.	JK	4/27/10
ENG APPR.	CC	4/27/10
MFG APPR.	CC	4/27/10

PROPRIETARY AND CONFIDENTIAL

THE INFORMATION CONTAINED IN THIS DRAWING IS THE SOLE PROPERTY OF RESOURCE CONSERVATION TECHNOLOGIES, INC. ANY REPRODUCTION IN PART OR AS A WHOLE WITHOUT THE WRITTEN PERMISSION OF RESOURCE CONSERVATION TECHNOLOGIES IS PROHIBITED.

**RESOURCE**

CONSERVATION TECHNOLOGIES  
64208 PARKLAND DRIVE SUITE 102  
SARASOTA, FL 34243 888-708-6622

TITLE:

AG-9100 SPECIFICATION SHEET

SIZE  
**A**

SCALE: 1:2

SHEET 1 OF 1

A