

REV	NOTES	DATE
01	Added mounting fasteners, box end printing. Removed label. DGR	8/14/12

**Fig. 1**

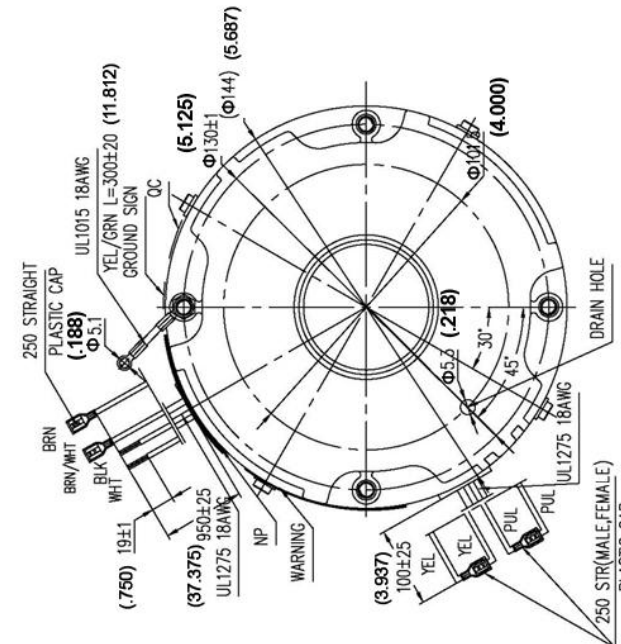

**Fig. 2**

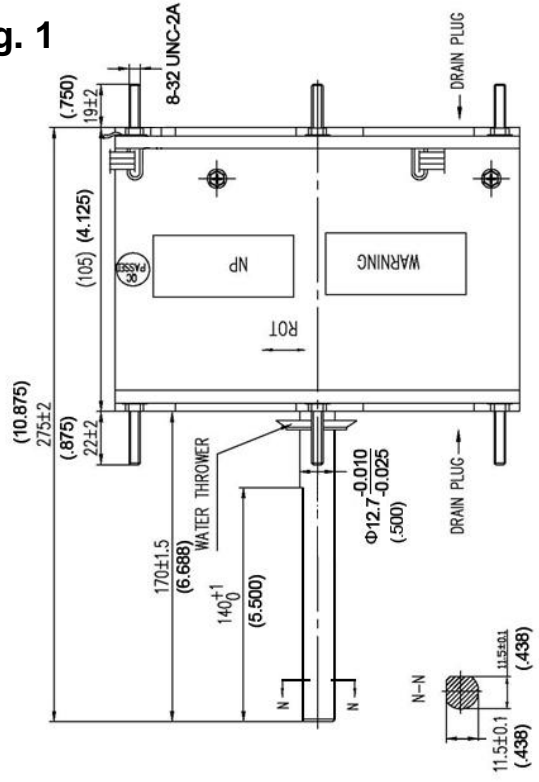
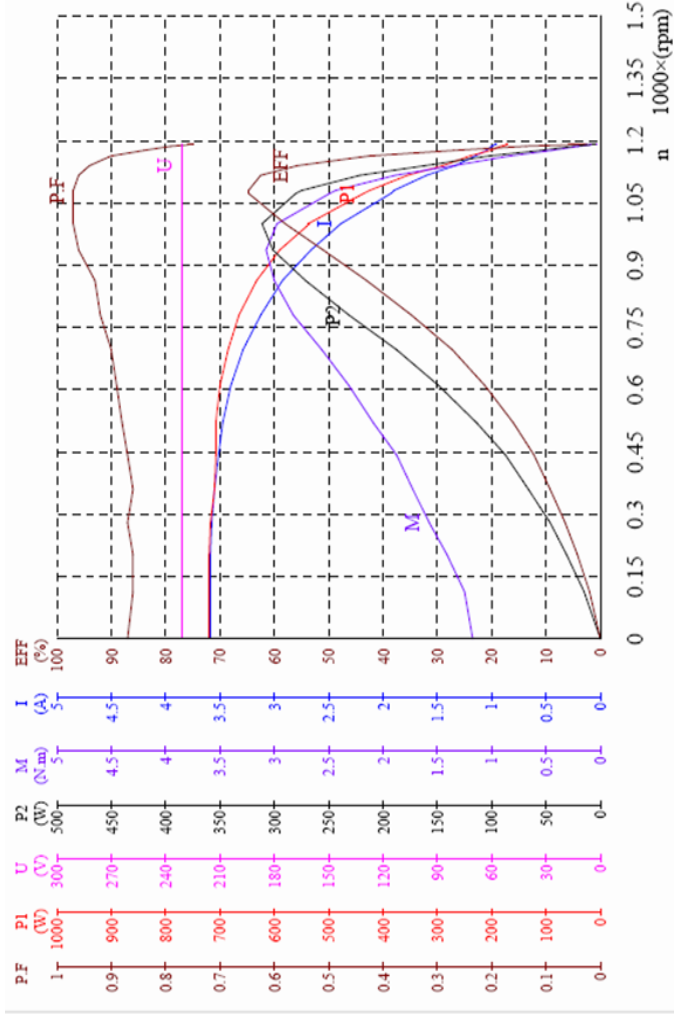

**Fig. 3**

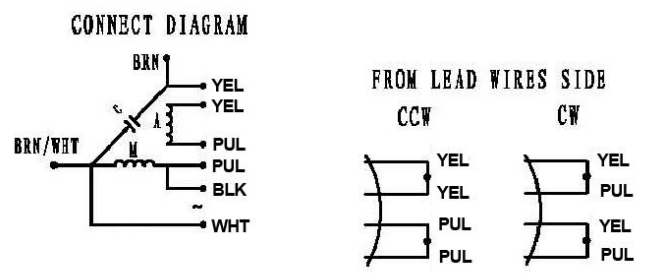

Part No. [s]

Drawn By: DGR 8/14/12  
Reviewed By: ESP 9/6/12  
Date:

**RHEEM CONFIDENTIAL INFORMATION.** NO REVISION TO DESIGN, MATERIAL, TOOLING OR PROCESS IS ACCEPTABLE WITHOUT PRIOR APPROVAL FROM RHEEM THROUGH A REVISED ENGINEERING SPECIFICATION AND A RESAMPLING OF PARTS. THE SUPPLIER IS RESPONSIBLE FOR NOTIFYING RHEEM PARTS DEPARTMENT AND PURCHASING DEPARTMENTS IN WRITING OF ANY CHANGES AFFECTING PRODUCT QUALITY, PERFORMANCE, RELIABILITY, PACKAGING, DELIVERY OR WORKMANSHIP. ANY DOCUMENTS REFERRED TO ON THIS DRAWING ARE INCLUDED IN THE SPECIFICATIONS FOR THIS COMPONENT.



**PROTECH UNIVERSAL 1/6-1/3 HP  
Direct Drive  
Outdoor Condenser Fan Motor – 208-240 V**

**W51-MHCJA1-01**  
Sheet 1 of 4

REV	NOTES	DATE
01	Added mounting fasteners, box end printing. Removed label. DGR	8/14/12

1. **Description** - 1/6-1/3 HP, 208-240 V, outdoor condenser fan motor suitable for residential and light commercial HVAC applications. Single speed with reversible rotation.
2. **Physical Characteristics:**
  - a. Dimensions - See Fig. 1. Primary dimensions and tolerances are in millimeters. Parenthetical reference dimensions are in inches.
  - b. Frame Designation - NEMA 48
  - c. Design Type - Permanent split capacitor (PSC) six pole induction motor.
  - d. Overload Protection - Automatic reset thermal protector in series with motor windings. Protector is embedded in direct contact within motor windings.
  - e. Insulation System - Class B (130 °C)
  - f. Winding Resistance at 25 °C - 21.11/40 ohms nominal
  - g. Endplates - Cast aluminum
  - h. Shell - Cold-rolled painted steel. Corrosion protection system shall comply with ASTM B117.
  - i. Motor shaft - Cold-rolled steel
  - j. Bearings - One provided in each end plate. Brass sleeve bearings. Permanent hydrodynamic lubrication. Bearing design shall comply with Rheem qualification tests CQP-12.4 and CQP-12.6.
  - k. Thru-bolts - Four 5-3/4 in. [14.6 cm] long 8-32 threaded through-bolts
  - l. Plug for Unused Drain Hole - One rubber plug capable of being removed and installed in the appropriate end plate to prevent water intrusion. Installed in factory for shaft-down operation in the endplate opposite the shaft
  - m. Water Slinger - One rubber washer water slinger installed on motor shaft
  - n. Grommet (Lead Wires) - Two rubber grommets installed in the motor shell to prevent wire chafing
  - o. **Additional hardware to be included:**
    - I. Four (4) #8-32 KEPS nuts or four (4) #8-32 flange nuts to be installed on the motor studs.  
*Optional* - Nuts can be supplied loose in a poly bag. Plating – Zinc
    - II. Four (4) #8-32 x 1/4 in. Phillips hex washer head screws installed on motor shell.  
*Optional* - Screws can be supplied loose in a poly bag. Plating – Zinc
3. **Application/Performance Characteristics:**
  - a. Mounting Methods - Thru-bolt, belly-band, or shell screw (8-36 x 1/4 in, "Rheem mount")
  - b. Mounting Orientation - Shaft-up or Shaft-down
  - c. Rotation Direction - Reversible (controlled via reversing leads)
  - d. Nominal RPM - 1075
  - e. Number of speeds - One
  - f. Torque-Speed Curve - Reference Fig. 2
4. **Electrical Ratings:**
  - a. Horsepower - 1/6-1/3 HP
  - b. Voltage - 208-240 VAC (Single Phase)
  - c. Frequency - 60Hz
  - d. Full Load Amps (FLA) - 1.92 A
  - e. Locked Rotor Amps (LRA) - 3.58 A
  - f. Required Run Capacitor - 7.5uF/370V



Part No. [s]

Drawn By: <u>DGR</u> 8/14/12 Reviewed By: <u>ESP</u> 9/6/12 Date: _____	<b>RHEEM CONFIDENTIAL INFORMATION.</b> NO REVISION TO DESIGN, MATERIAL, TOOLING OR PROCESS IS ACCEPTABLE WITHOUT PRIOR APPROVAL FROM RHEEM THROUGH A REVISED ENGINEERING SPECIFICATION AND A RESAMPLING OF PARTS. THE SUPPLIER IS RESPONSIBLE FOR NOTIFYING RHEEM PARTS DEPARTMENT AND PURCHASING DEPARTMENTS IN WRITING OF ANY CHANGES AFFECTING PRODUCT QUALITY, PERFORMANCE, RELIABILITY, PACKAGING, DELIVERY OR WORKMANSHIP. ANY DOCUMENTS REFERRED TO ON THIS DRAWING ARE INCLUDED IN THE SPECIFICATIONS FOR THIS COMPONENT.	
 <b>Parts Engineering</b>	<b>PROTECH UNIVERSAL 1/6-1/3 HP Direct Drive Outdoor Condenser Fan Motor – 208-240 V</b>	<b>W51-MHCJA1-01</b>
		Sheet 2 of 4

REV	NOTES	DATE
01	Added mounting fasteners, box end printing. Removed label. DGR	8/14/12

**5. Electrical Connections:**

- a. Conductors - All conductors shall be 18 AWG stranded copper wire. Minimum length 37 in. [94.0 cm], except ground lead, minimum 11.8 in. [30.0 cm]. Length of reversing leads is not specified.
- b. Insulation:
  - i. Type - UL Recognized Appliance Wiring Material, with minimum ratings of 600V, 105C, VW-1.
  - ii. Thickness - Min 3/64 in. [1.19 mm], except ground lead, min. 1/32 in. [0.79 mm]
  - iii. Color - See Fig. 3. Ground lead shall be green or green with a yellow stripe.
- c. Terminations:
  - i. Capacitor Leads - 1/4 in. fully insulated quick connect terminals
  - ii. Ground Lead - Ring terminal with internal paint breaking serrated edge
  - iii. Reversing Leads - Mating male/female fully insulated quick connect terminals

6. **Agency Certifications** - The motor shall comply with the requirements of UL 1004 and UL 2111, and be UL Recognized under the PRGY2 and XEWR2 product categories. UL File Number E256965.

7. **Marking/Labeling** - The labels shown in Fig. 5 and Fig. 6 and Fig. 7 shall be provided on the motor shell. Labels shall be provided on a UL Recognized Component Marking and Labeling System (PGDQ2 product category) suitable for outdoor use on a painted steel surface, with a rated temperature range of -35°F to 130°F [-37C to 55C]. A date or batch code shall be provided in the area marked "xxxxxxx". The vendor part number shall be provided in the area marked "Yxxxxxxx".

**8. Individual Packaging:**

- a. Carton Material:
  - i. Outside linerboard to be white
  - ii. Double wall construction
  - iii. Complies with ECT (edge crush test) of at least 32 pounds/in.
  - iv. Minimum 1 ¼" glue tab; manufacturer's joint to be stitched or glued
  - v. Gross weight capacity should be at least 65 pounds
- b. Each box shall be provided with internal packing or support adequate to prevent motor movement within box.
- c. Marking/Labeling - Representative content shown in Fig. 4 shall be color printed on faces of the box. Bar Code shall be in 3 of 9 format. UPC number is 662766406900. A date or batch code shall be provided in the area marked "xxxxxxx". See artwork - **Condenser Motor Box\_MHC.ai** for size, CMYK color and layout.



Part No. [s]

Drawn By: <u>DGR</u>	<u>8/14/12</u>
Reviewed By: <u>ESP</u>	<u>9/6/12</u>
Date:	

**RHEEM CONFIDENTIAL INFORMATION.** NO REVISION TO DESIGN, MATERIAL, TOOLING OR PROCESS IS ACCEPTABLE WITHOUT PRIOR APPROVAL FROM RHEEM THROUGH A REVISED ENGINEERING SPECIFICATION AND A RESAMPLING OF PARTS. THE SUPPLIER IS RESPONSIBLE FOR NOTIFYING RHEEM PARTS DEPARTMENT AND PURCHASING DEPARTMENTS IN WRITING OF ANY CHANGES AFFECTING PRODUCT QUALITY, PERFORMANCE, RELIABILITY, PACKAGING, DELIVERY OR WORKMANSHIP. ANY DOCUMENTS REFERRED TO ON THIS DRAWING ARE INCLUDED IN THE SPECIFICATIONS FOR THIS COMPONENT.



**PROTECH UNIVERSAL 1/6-1/3 HP  
Direct Drive  
Outdoor Condenser Fan Motor – 208-240 V**

<b>W51-MHCJA1-01</b>
Sheet 3 of 4

REV	NOTES	DATE
01	Added mounting fasteners, box end printing. Removed label. DGR	8/14/12

**Fig. 4**



**Fig. 5**

**IMPORTANT NOTE:** This motor is suitable for operation in either shaft-up or shaft-down orientation. A rubber plug is included with the motor. This plug must be installed on the TOP of the motor to ensure rain does not enter the motor from the unused drain plug. The bottom drain hole should be left open to allow any condensation to escape.

**WIRING DIAGRAM**

Label size:  
1.375 in. x 4.25 in.

**Fig. 6**

Yxxxxxxxxx Made in China E256965	<b>PN: W51- MHCJA1 - 01</b> HP: 1/6 -1/3 RPM: 1075 Voltage: 208-240V-60Hz-1ph FLA/LRA: 1.92 / 3.58A Capacitor: 7.5uF/370V Rotation: Reversible Thermally Protected A0 - Class B (130°C)	
	PROTECH UNIVERSAL	

Label size:  
1.375 in. x  
7.00 in.

**Fig. 7**

	<b>DANGER</b>
	TO AVOID ELECTRICAL SHOCK USE ONLY THE SCREWS FURNISHED IN THE MOTOR SHELL MOUNTING HOLES.  SCREWS ARE #8-32 X .25 LONG THREAD FORMING. LONGER SCREWS MAY CONTACT THE WINDING

Label size:  
2.75 in. x  
1.375 in.

Part No. [s]

Drawn By: <u>DGR</u> 8/14/12  Reviewed By: <u>ESP</u> 9/6/12 Date: _____	<b>RHEEM CONFIDENTIAL INFORMATION.</b> NO REVISION TO DESIGN, MATERIAL, TOOLING OR PROCESS IS ACCEPTABLE WITHOUT PRIOR APPROVAL FROM RHEEM THROUGH A REVISED ENGINEERING SPECIFICATION AND A RESAMPLING OF PARTS. THE SUPPLIER IS RESPONSIBLE FOR NOTIFYING RHEEM PARTS DEPARTMENT AND PURCHASING DEPARTMENTS IN WRITING OF ANY CHANGES AFFECTING PRODUCT QUALITY, PERFORMANCE, RELIABILITY, PACKAGING, DELIVERY OR WORKMANSHIP. ANY DOCUMENTS REFERRED TO ON THIS DRAWING ARE INCLUDED IN THE SPECIFICATIONS FOR THIS COMPONENT.	_____ _____ _____
<b>Parts Engineering</b>	<b>PROTECH UNIVERSAL 1/6-1/3 HP Direct Drive Outdoor Condenser Fan Motor – 208-240 V</b>	<b>W51-MHCJA1-01</b>
		Sheet 4 of 4