

NOTE:  
 ALL OUTSIDE DIMENSIONS SHOWN WITH  $\rightarrow$   
 ALL INSIDE DIMENSIONS SHOWN WITH  $\rightarrow$

STACK BASE LINE  
 $\rightarrow$   $\rightarrow$

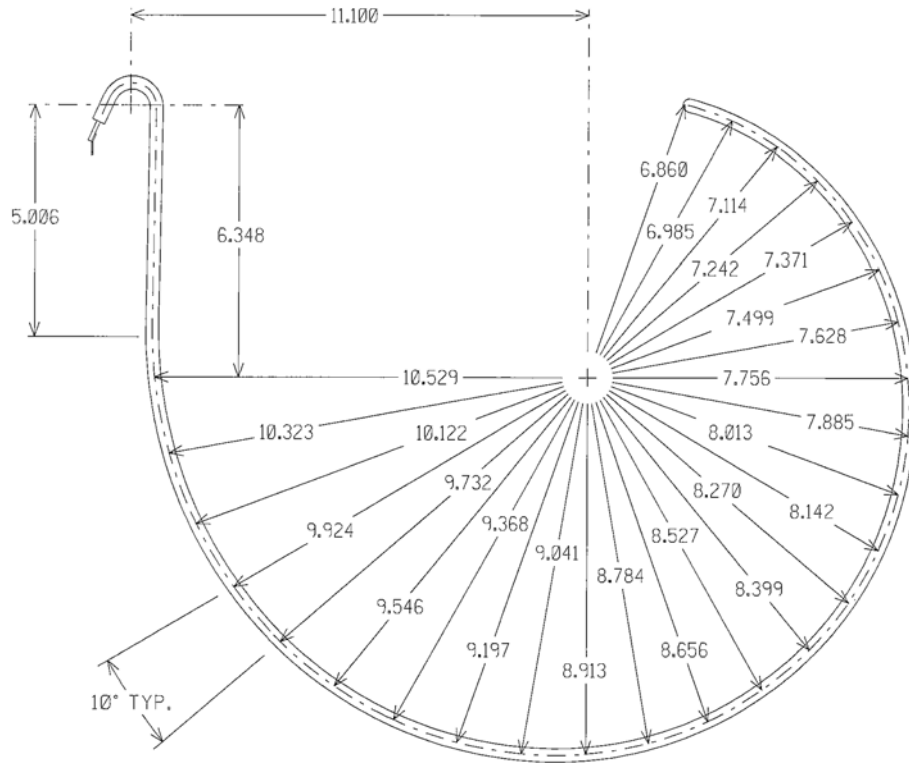

AE-50423-02  
 Mounting Bracket  
 3 pieces



ELEMENT MATERIAL : 840 INCOLOY  
 240 VOLTS --- 3500 WATTS (3.5KW)

NOTICE TAG WORDING :  
 THIS ELEMENT IS FOR COLOR CODE "GREEN". IT  
 CAN BE USED TO REPLACE "GREEN OR RED  
 COLOR CODE".

HEATING ELEMENT KIT CONSIST OF:

QTY PART

- (1) ELEMENT
- (1) INSTALLATION INSTRUCTION
- (3) MOUNTING BRACKETS
- (3) SCREWS
- (1) NOTICES TAG
- (1) CARTON
- (1) WIRE TIE

PART NO.

- AS-58386-12
- 92-23138-01-00
- AE-50423-02
- 63-22153-05
- 92-22205-92-00
- 99-17100-31
- 64-17606-01

Reference 44-23104-12 for additional Heating Element information.

CHECKED				
APPROVED	STANDARD TOLERANCE			
RELIAB. ENGR.	- FRACTIONAL $\pm 1/32"$			
VENDOR	- ANGULAR $\pm 1^\circ - 3^\circ$			
	- DECIMAL $\pm 0.030$			
<b>PROSTOCK™</b>	MODELED BY: L. STEC DATE: 01-24-04	ORIGINAL <b>P00161</b> RELEASE NO.	NOTE: ALL BREAKS ARE 90° UNLESS OTHERWISE SPECIFIED.	MATERIAL
	RHEEM MFG. PARTS DEPARTMENT	<b>FORMED SHEATH HEATER &amp; BRACKET ASSEMBLY</b>		PART NO. <b>AS-58386-92</b> SHEET 1 OF 2 REV. <b>00</b>



**PART CONVERSION FORM  
( PCF ) 992**

PCF Part Number : **AS-58386-92**  
 Description : **Sheath Heater Kit**  
 Set-up By : **L. Stec**

Origination Date: **08/09/97**  
 Revision: **-02**  
 Revision Date: **01/28/04**  
 Revised by: **L.Stec**

LINE ITEM	PART NUMBER	QTY.	DESCRIPTION	NOTES
1	AS-58386-12	1	Sheath Heater	3.5KW @ 240volt
2	AE-50423-02	3	Mounting Brackets	
3	63-22153-05	3	Screws	
4	64-17606-01	1	Wire Tie	
5	92-23138-01-00	1	Instructions	
6	92-22205-92-00	1	Notice Tag	
7	99-17100-31	1	Carton	
8				
9				
10				Rev. -02 made to update PCF to Bill of Material
11				piece part listings. These kits are assembled
12				complete in Milledgeville.
13				
14				
15				
16				
17				
18				
19				
<b>Deviation Notes</b>				<b>Deviation Approval:</b> _____ <small>Signature</small> / /

**INSTRUCTIONS :**

--

**PROSTOCK PARTS DEPARTMENT ITEM**

Description :	Part No.	Rev.
<b>Sheath Heater Kit</b>	<b>AS-58386-92</b>	<b>-02</b>