

1. Description - Enclosed type 30A fused pull-out switch for outdoor use. Intended for HVAC applications, and suitable for installation per Articles 404 and 440 of the National Electrical Code (NFPA70).

2. Enclosure:

- a. Environmental Rating - NEMA 3R (Rainproof - Outdoor Use)
- b. Dimensions - See Fig. 1. Dimensions are in inches, reference only
- c. Material - Galvanized steel, min 0.039 in. [0.990 mm]
- d. Corrosion Protection System - Grey powder coat
- e. Door - Top hinged, latching style
- f. Dead front - Steel deadfront prevents access to live parts during switch operation.
- g. Knockouts - Concentric knockouts (trade sizes 1/2, 3/4, and 1 in.) provided in the following locations:
 - i. Bottom (2)
 - ii. Left Side (1)
 - iii. Right Side (1)
 - iv. Back (2)
- h. Mounting Method - Shall be provided with bosses or tabs, similar to those shown in Fig. 1 to securely mount the box.
- i. Lock - Provided with a lockable latch

3. Electrical Ratings (Values shown are minimums):

- a. Voltage - 240 V
- b. Current - 30 A
- c. Horsepower:
 - i. Standard - 1/2 HP, 1 Phase, 240 V
 - ii. Maximum - 3 HP, 1 Phase, 240 V
- d. Fuses - 30 A, cartridge-type branch circuit fuses
- e. Electrical Connections:
 - i. Wire Type - Shall be suitable for both Copper and Aluminum, both Solid and Stranded, and for both 60C and 75C insulation
 - ii. Wire Size - Shall include the range 4-14 AWG
 - iii. Terminal Type:
 - 1. Power Terminals - Pressure lug terminals with slotted screw heads
 - 2. Ground/Neutral Terminals - Aluminum terminal bar with slotted screw heads

4. Agency Certifications - Switch shall be UL and C-UL Listed.

5. Packaging:

- a. Ten (10) disconnects per carton
- b. Instructions - Switch shall be provided with installation instructions, located inside switch compartment.
- c. Carton Size - Approximately 18-1/2 in. x 14-1/2 in. x 8-1/2 in. [47 cm x 37 cm x 47 cm]
- d. Carton material:
 - i. Double wall construction
 - ii. Complies with ECT (edge crush test) of at least 100 pounds/in. [7.03 kg/cm]
 - iii. Gross weight capacity shall be at least 65 pounds [29.5 kg]
- e. Markings - The following information shall be provided in minimum font size of 16pt:
 - i. Rheem Part Number
 - ii. Description
 - iii. Quantity
 - iv. Country of Origin
 - v. Rheem standard bar code requirements (to be provided by Rheem purchasing agent)

<p>CONFIDENTIAL</p> <p><small>THIS PRINT AND THE SPECIFICATIONS ARE THE PROPERTY OF RHEEM MANUFACTURING AND HAS BEEN ISSUED WITH THE UNDERSTANDING THAT IT WILL NOT BE REPRODUCED, REVEALED TO OR USED FOR THE MANUFACTURE FOR OTHERS, AND WILL BE RETURNED UPON REQUEST.</small></p>	<p>STANDARD TOLERANCE UNLESS OTHERWISE SPECIFIED</p> <p>-FRACTIONAL ±1/32 -ANGULAR ±2° -DECIMAL 2 Plc ±.03 3 Plc ±.010 -DIMENSIONS IN () REF. ONLY</p>	<p>R E V I S I O N S</p>	<p>02</p>	<p>CONVERTED TO PRO-E TEMPLATE. UPDATED DIMES TO REF. REMOVED PROTECH EMBOSS & CHINESE TRANSLATIONS. DGR</p>	<p>1-29-13</p>
			<p>01</p>	<p>CHGD. Border, opened specs., door, mounting, PROTECH removed, DGR</p>	<p>7-2-12</p>
	<p>NO REVISION TO DESIGN, MATERIAL, TOOLING, OR PROCESS IS ACCEPTABLE WITHOUT PRIOR APPROVAL FROM RHEEM THROUGH A REVISED ENGINEERING SPECIFICATION AND A RESAMPLING OF PARTS. THE SUPPLIER IS RESPONSIBLE FOR NOTIFYING RHEEM PARTS DIVISION IN WRITING OF ANY CHANGES AFFECTING PRODUCT QUALITY, PERFORMANCE, RELIABILITY, PACKAGING, DELIVERY OR WORKMANSHIP. ANY DOCUMENTS REFERRED TO ON THIS DRAWING ARE INCLUDED IN THE SPECIFICATIONS FOR THIS COMPONENT.</p>				
 <p>Replacement Parts Division</p>	<p>MODELED BY DGR 1-29-13 APPROVED BY WCM 1-29-13</p>		<p>NOTE: ALL BRAKES ARE 90° UNLESS OTHERWISE SPECIFIED</p>		
	<p>PULL OUT SWITCH 30 AMP FUSED</p>			<p>PART NO. 84-25175-04</p>	<p>SHEET 1 of 2</p>

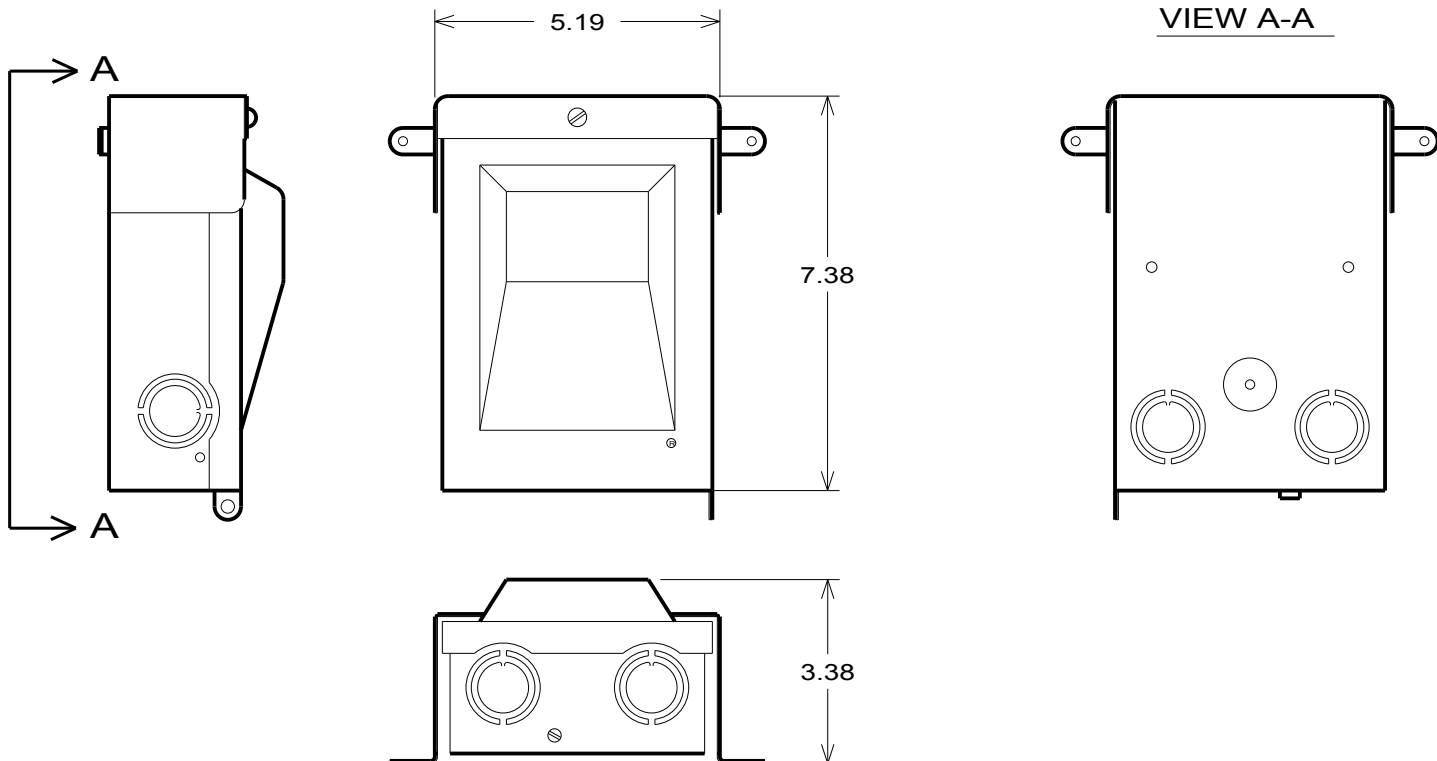

**DETAIL B:
INTERIOR VIEW**

Fuse block, cover, and inner cover have been removed to show interior.

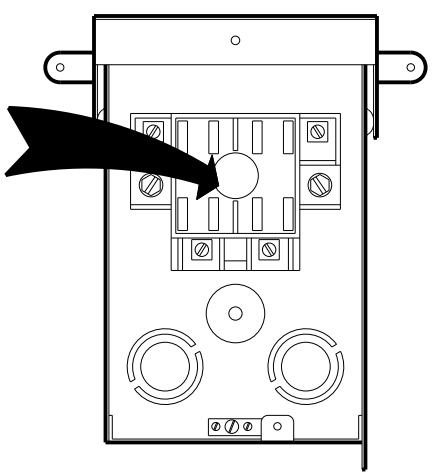
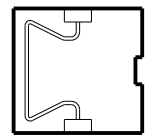

<p>CONFIDENTIAL</p> <p>THIS PRINT AND THE SPECIFICATIONS ARE THE PROPERTY OF RHEEM MANUFACTURING AND HAS BEEN ISSUED WITH THE UNDERSTANDING THAT IT WILL NOT BE REPRODUCED, REVEALED TO OR USED FOR THE MANUFACTURE FOR OTHERS, AND WILL BE RETURNED UPON REQUEST.</p>	<p>STANDARD TOLERANCE UNLESS OTHERWISE SPECIFIED</p> <p>-FRACTIONAL $\pm 1/32$</p> <p>-ANGULAR $\pm 2^\circ$</p> <p>-DECIMAL 2 Ptc $\pm .03$</p> <p>3 Ptc $\pm .010$</p> <p>-DIMENSIONS IN () REF. ONLY</p>	<p>R E V I S I O N S</p>		
		<p>02</p>	<p>CONVERTED TO PRO-E TEMPLATE. UPDATED DIMS TO REF. REMOVED PROTECH EMBOSS & CHINESE TRANSLATIONS. DGR</p>	<p>1-29-13</p>
		<p>01</p>	<p>CHGD. Border, opened specs., door, mounting, PROTECH removed, DGR</p>	<p>7-2-12</p>
<p>NO REVISION TO DESIGN, MATERIAL, TOOLING, OR PROCESS IS ACCEPTABLE WITHOUT PRIOR APPROVAL FROM RHEEM THROUGH A REVISED ENGINEERING SPECIFICATION AND A RESAMPLING OF PARTS. THE SUPPLIER IS RESPONSIBLE FOR NOTIFYING RHEEM PARTS DIVISION IN WRITING OF ANY CHANGES AFFECTING PRODUCT QUALITY, PERFORMANCE, RELIABILITY, PACKAGING, DELIVERY OR WORKMANSHIP. ANY DOCUMENTS REFERRED TO ON THIS DRAWING ARE INCLUDED IN THE SPECIFICATIONS FOR THIS COMPONENT.</p>				

 <p>Replacement Parts Division</p>	<p>MODELED BY DGR 1-29-13</p> <p>APPROVED BY WCM 1-29-13</p>	<p>NOTE: ALL BRAKES ARE 90° UNLESS OTHERWISE SPECIFIED</p>	<p>PART NO. SHEET 2 of 2 REV</p>
	<p>PULL OUT SWITCH 30 AMP FUSED</p>		<p>84-25175-04 - 02</p>