

REV	NOTES	DATE

Fig. 1 – 11", 54 Blades

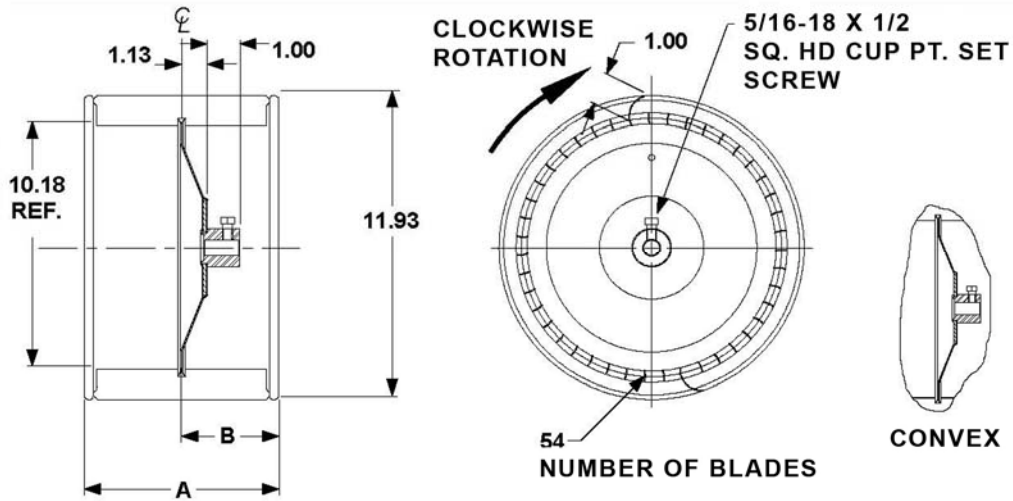

Notes:

1. No keyway
2. Finish: Galvanized
3. Material: Steel

Rheem PN	Morrison PN	O.D. (in.)	Width Dim A (in.)	Nominal Size	# Blades	Dim B (in.)	HUB Bore Dia. (in.)	Rotation (hub end)	Disc Shape (hub side)	No. Set Screws	Weight * (lbs.)	Fig.No.
703015	03-56031	11.93	11.93	11 X 11	54	5.96	.50	CW	Convex	2	7.3	1

Part No. [s]

Drawn By: DGR 8/13/07
Reviewed By: ESP 8/17/07
Date:

NO REVISION TO DESIGN, MATERIAL, TOOLING OR PROCESS IS ACCEPTABLE WITHOUT PRIOR APPROVAL FROM RHEEM THROUGH A REVISED ENGINEERING SPECIFICATION AND A RESAMPLING OF PARTS. THE SUPPLIER IS RESPONSIBLE FOR NOTIFYING RHEEM PARTS DEPARTMENT AND PURCHASING DEPARTMENTS IN WRITING OF ANY CHANGES AFFECTING PRODUCT QUALITY, PERFORMANCE, RELIABILITY, PACKAGING, DELIVERY OR WORKMANSHIP. ANY DOCUMENTS REFERRED TO ON THIS DRAWING ARE INCLUDED IN THE SPECIFICATIONS FOR THIS COMPONENT.



Parts Department

Blower Wheel

703015

Sheet 1 of 1