

UNIVERSAL PARTS MOTORS

MFG: General Electric MODEL: 5KCP39RGU006S MFG: Emerson MODEL: K55HXDRJ-0011
 H. P. 3/4* RPM 1075 SPEEDS 4 VOLTS 115 PH 1 HZ 60 CAP 10, 12.5 or 15^o/370 @115
 F. L. AMPS 9.5* LR - ROTATION Rev (OSE) FRAME 48 THERMALLY PROTECTED Yes WIND. CLASS B
 SHAFT 1/2" X 5" FLAT 4" MOTOR TYPE PSC STACK 2.75" BEARINGS Ball OIL See back of Instr
 TORQUE: HI 79 OZ FT (BD) @ 950 RPM M/Hi 62.5 OZ FT (BD) @ 950 RPM M/LO 43 OZ FT (BD)
 @ 930 RPM LO 33 OZ FT (BD) @ 930 RPM @ 115 VOLT 10/370 CAP.

Enclosure
All position
Open Motor

MOUNTING: THRU BOLT Yes SHELL BAND Yes SHELL HOLES Yes HUB RINGS No
 SHAFT POSITION All SHAFT END VENTED Open BUTT END VENTED Open SHELL VENTED Open

	HI	MED/HI	MED/LOW	LO	AUX.	Temp. °C
WINDING RESISTANCE @ 23°C — OHMS	1.5	1.9	2.6	3.3	21.6	23

DESIGN NOTES: MOTOR SAME AS _____ or A DESIGN OF 51-22700-01
 SPECIAL CONSIDERATIONS: *Motor HP ratings are 1/2, 1/3, 1/4, 1/5, 1/6. *Actual Full Load test amps are: Hi 13.3, M/Hi 11.0, M/Lo 10.3 & Lo 8.8 with 15/370 Capacitor • Motor Design Capacitor is 15/370, see instructions. Motor is shipped with instructions, GE Stuffer is SFM2439, Rheem Number 92-26177-315-00, Emerson Instructions F40531761, Rheem Instruction 92-26177-315-00. Both motors are shipped with eight (8) shell screws, and four (4) thru bolt nuts in a plastic bag. Print was prepared from Emerson data.

Wire Information: Lead Insulation Rating 105°C
 Thickness 4/64" Type Material PVC

Leads	Color	Wire Ga.	Length	Termination
Common	White	18	36"	1/4 QC Flag
High	Black	18	36"	1/4 QC Flag
M/Hi	Blue	18	36"	1/4 QC Flag
M/Lo	Yellow	18	36"	1/4 QC Flag
Lo	Red	18	36"	1/4 QC Flag
Capacitor	Brown	18	36"	1/4 QC Flag
Capacitor	Brown	18	36"	1/4 QC Flag
Ground	Green	18	5"	1/4 Eyelet

Reversing Leads are (1) Orange and (1) Purple 3" Long

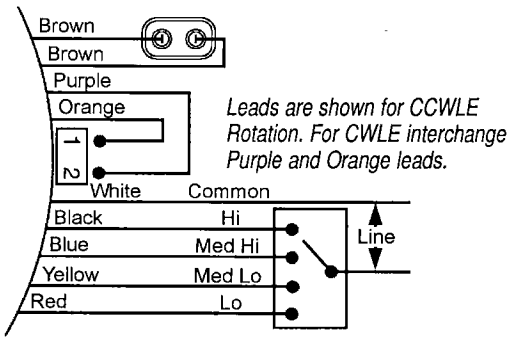

REVISIONS

00	Emerson's Stuffer Number Changed from R960903RT315 to 92-26177-315-00
00	General Electric's Stuffer Number is the same as 92-26177-315-00

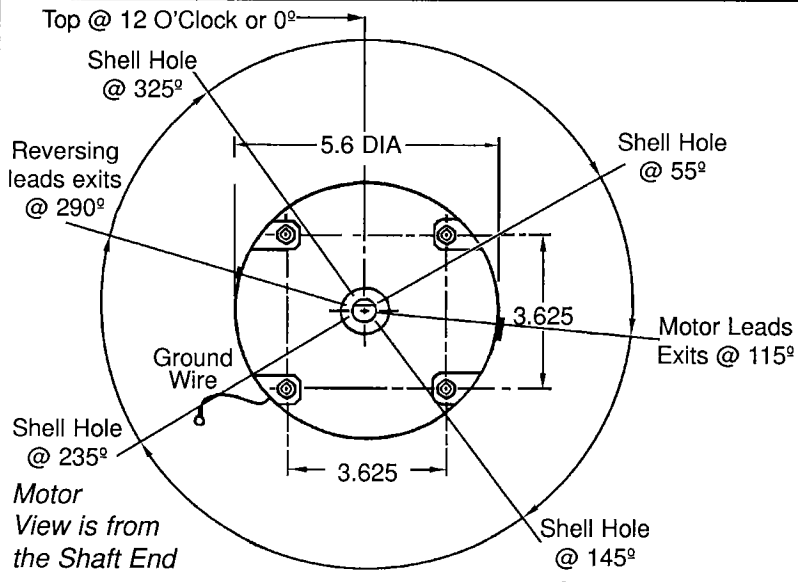

Shell Screws 8-18, p/n 63-22338-03.

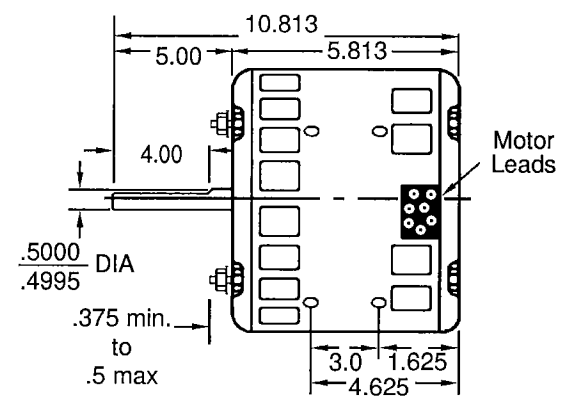

NOTE: Thru Bolts (8-32) are Reversible.

RHEEM MANUFACTURING CO. PARTS DEPARTMENT

DR. BY: W. Charles | CHKD. BY: Robert Thomas | APPROVED BY: Baykal Altiner | DATE 05/03/1999 | ORIGINAL RELEASE Y-0119S000 | REV. -00

3/4 HP 4 Speed (115V) Direct Drive Furnace Blower Motor

PART NO. 51 - 23017 - 42